

GSM/GPRS PA and Antenna Switch

WCDMA PA

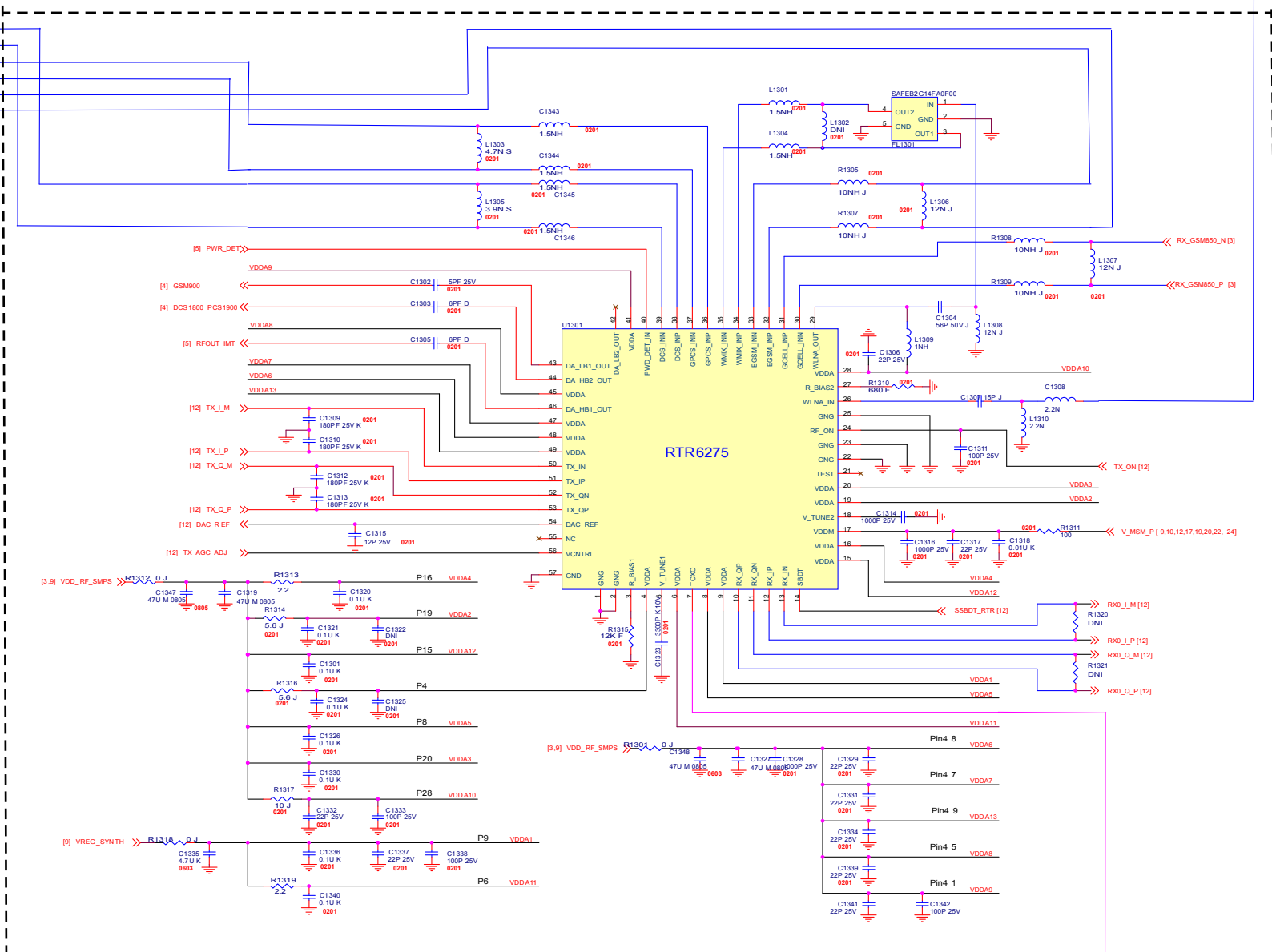

Qualcomm RTR6275 RF Transceiver

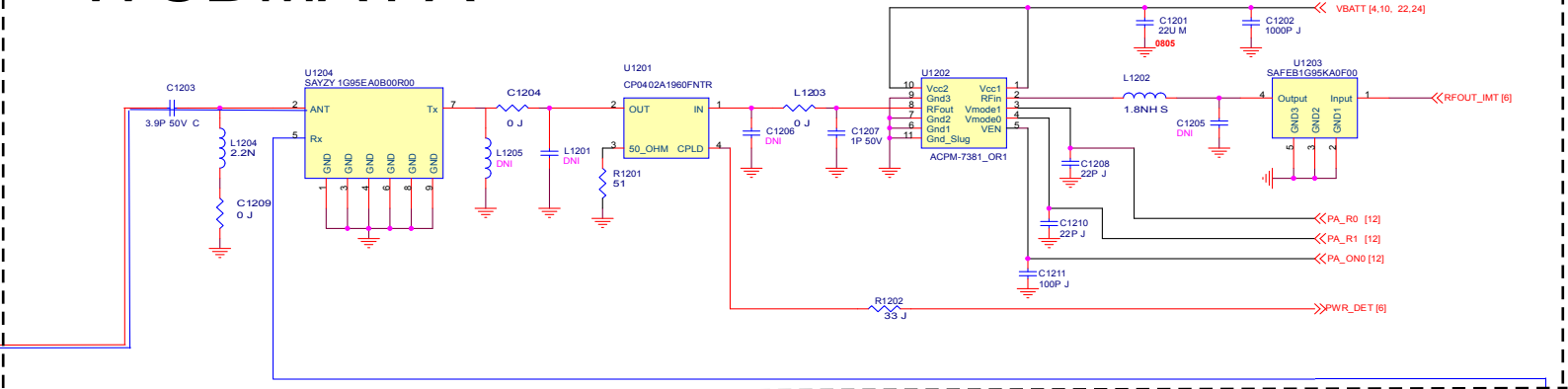
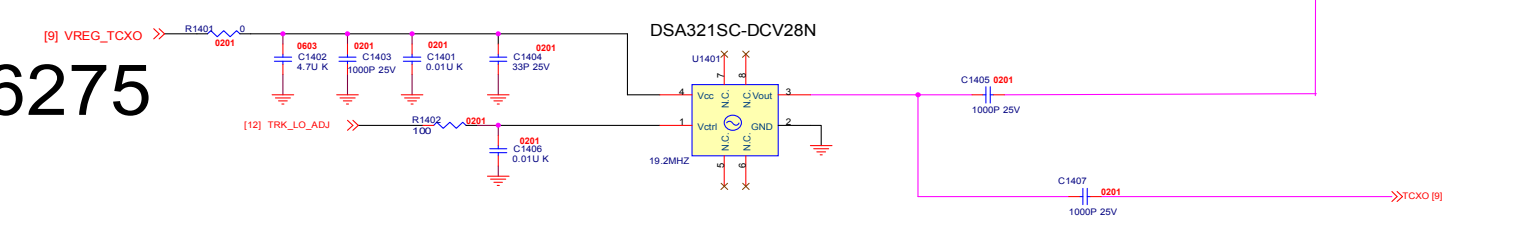

VE538



Service, Engineering & Optimization	2008/09/12
Level 3 Schematics	Rev. 1.0
VE538	4H.0H101.A01
Repair Optimization Service Training	Page 1 of 13

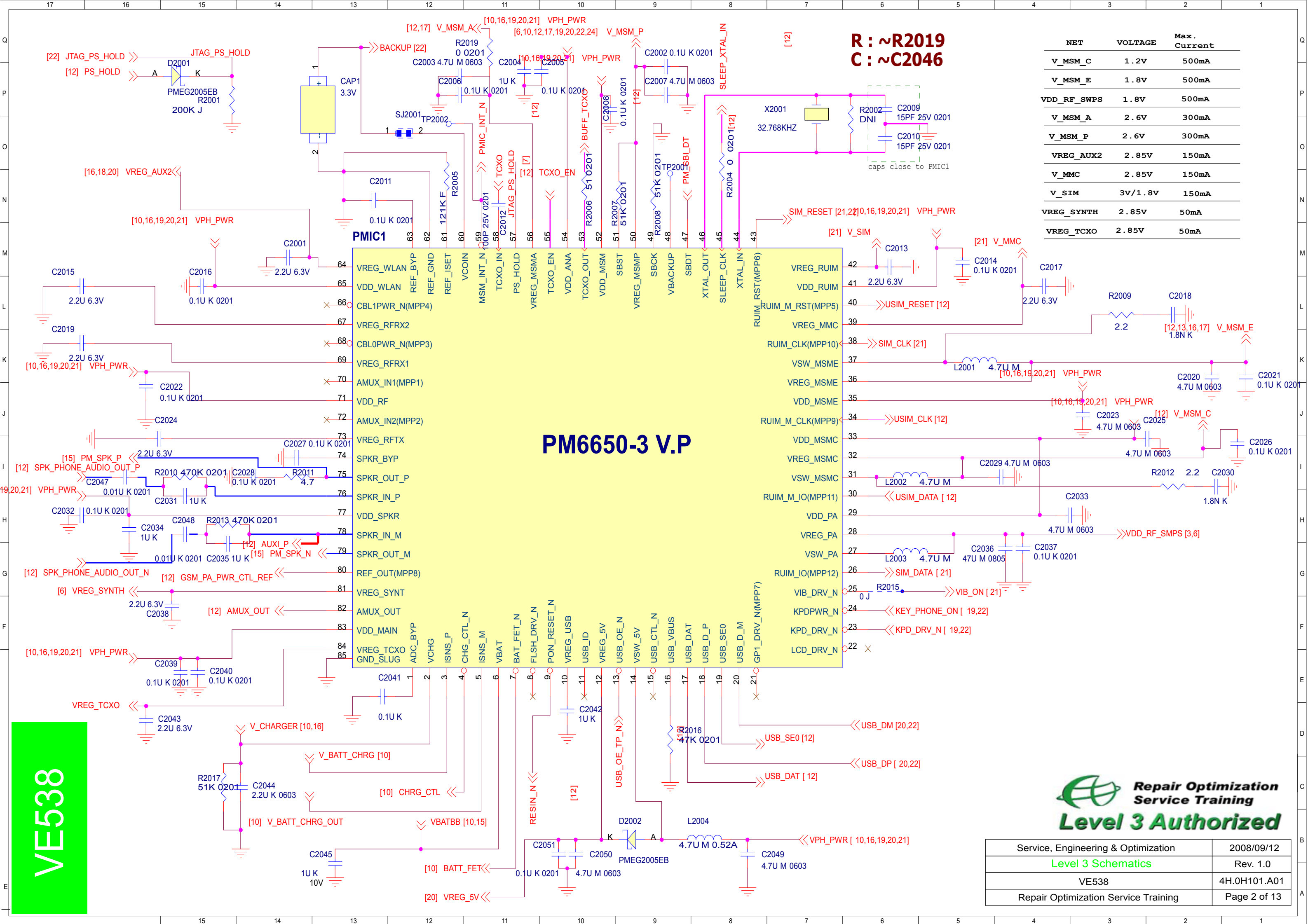

R : ~R2019
C : ~C2046

NET	VOLTAGE	Max. Current
V_MSM_C	1.2V	500mA
V_MSM_E	1.8V	500mA
VDD_RF_SWPS	1.8V	500mA
V_MSM_A	2.6V	300mA
V_MSM_P	2.6V	300mA
VREG_AUX2	2.85V	150mA
V_MMC	2.85V	150mA
V_SIM	3V/1.8V	150mA
VREG_SYNTH	2.85V	50mA
VREG_TCXO	2.85V	50mA

PM6650-3 V.P



Service, Engineering & Optimization	2008/09/12
Level 3 Schematics	Rev. 1.0
VE538	4H.OH101.A01
Repair Optimization Service Training	Page 2 of 13

VE538

VDD_C = 1.2V
VDD_A = 2.6V
VDD_P1 = 1.8V/2.6V
VDD_P2 = 2.6V
VDD_P3 = 2.6V
VDD_P4 = 2.6V

VMSM_C = 1.2V
VMSM_A = 2.6V
VMSM_E = 1.8V
VMSM_P = 2.6V

R : ~R3029
C : ~C3036
TP : ~TP3030

MSM1

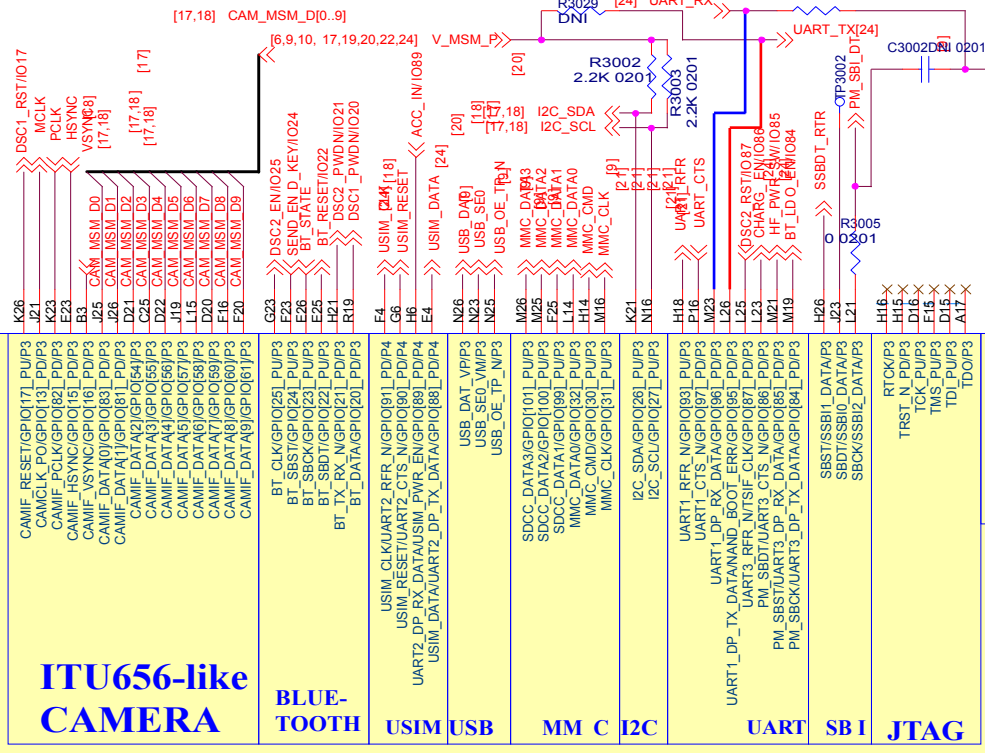
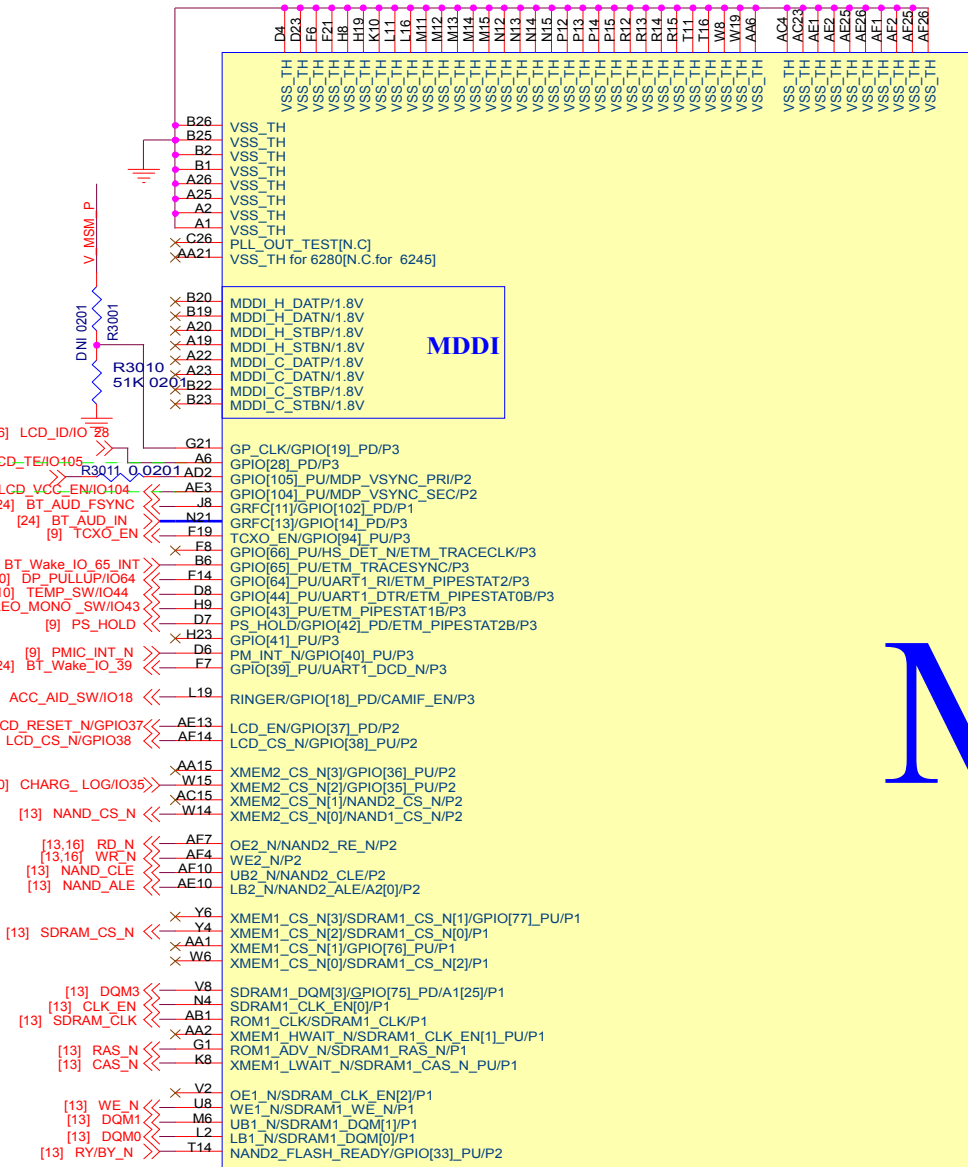

CODEC

RF TX

RF RX

KSENSE KSCAN

CLOCKS RESETS MODES

MSM6245

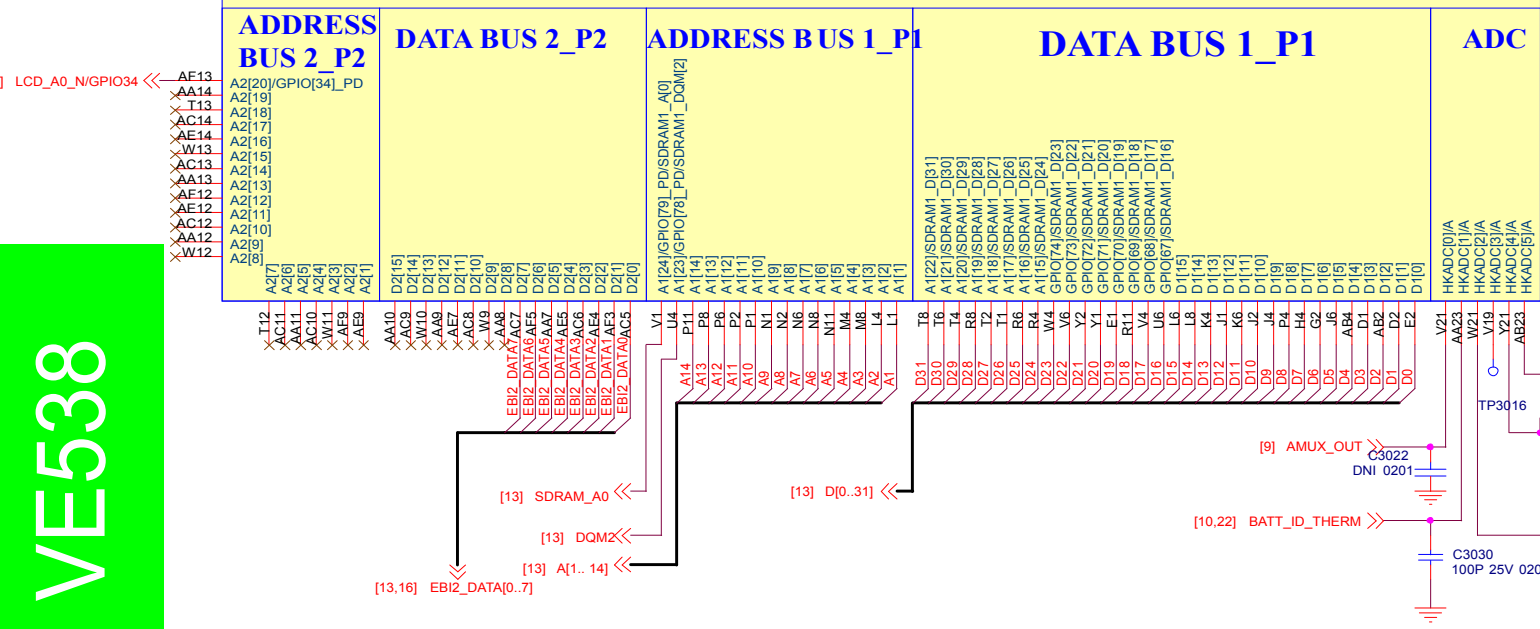

POWER/GROUND

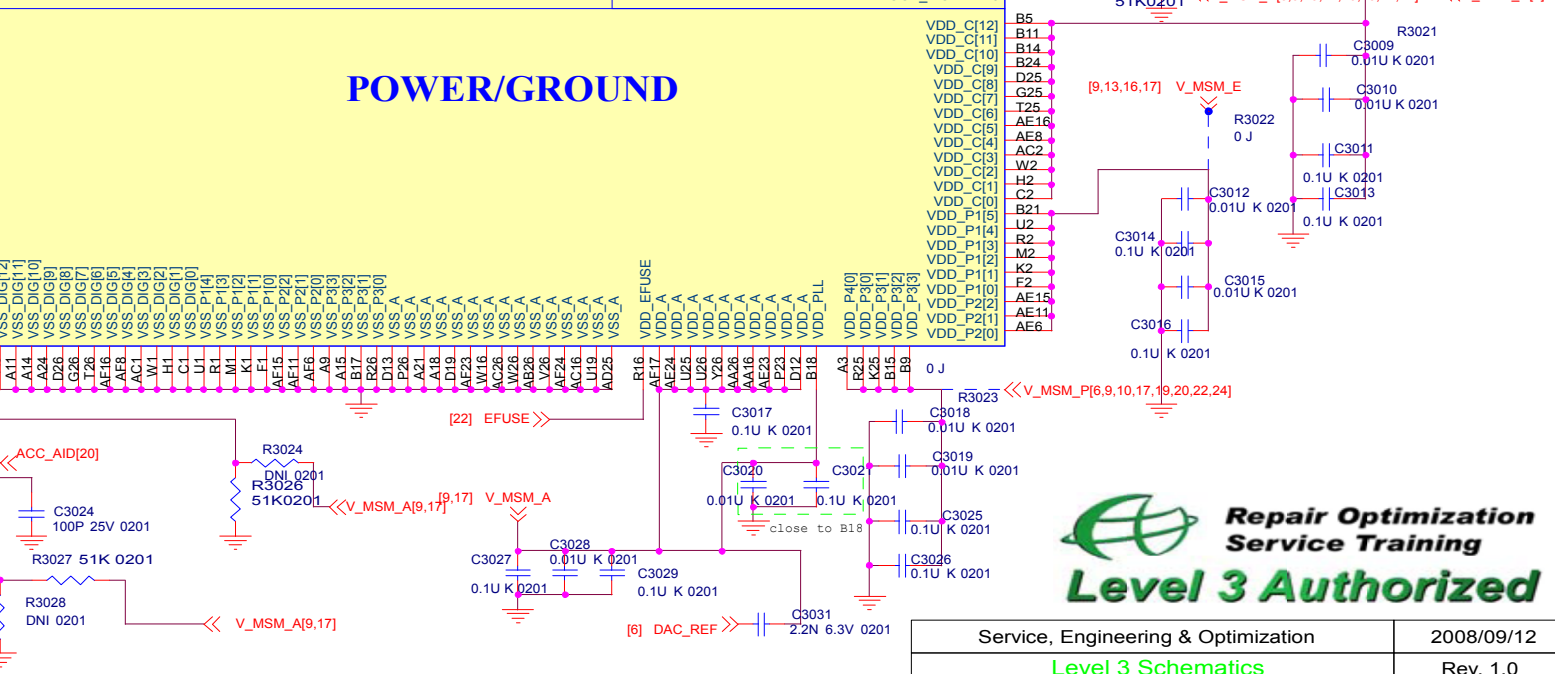

VE538



Service, Engineering & Optimization	2008/09/12
Level 3 Schematics	Rev. 1.0
VE538	4H.0H101.A01
Repair Optimization Service Training	Page 3 of 13

R : ~R3108
C : ~C3106

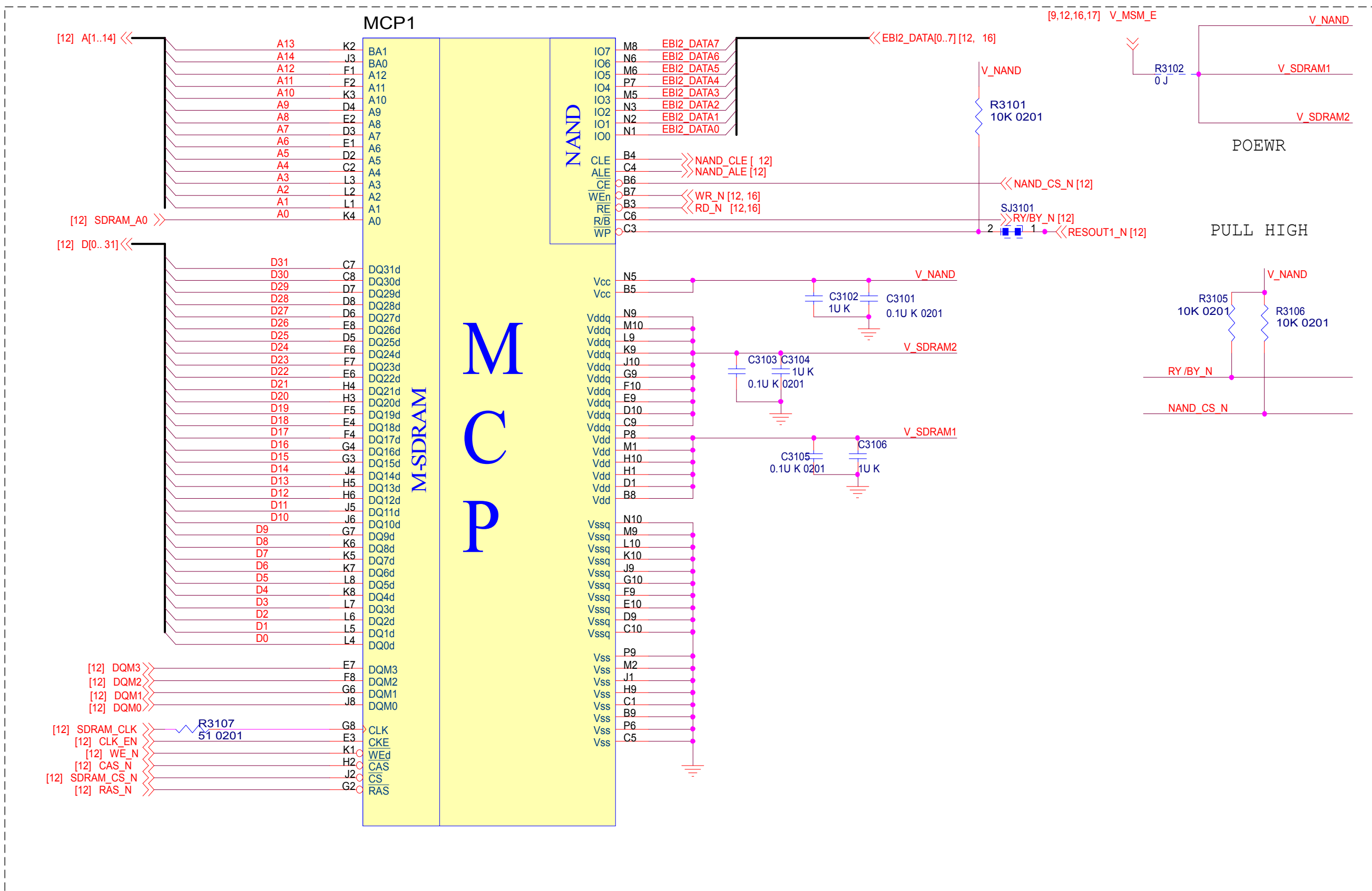

FD1
1
FIDUCIAL

FD2
FIDUCIAL

TH1
1
TH

TH3
1
TH

VE538

MCP Memory (512Mb NAND Flash + 512Mb SDRAM)



Service, Engineering & Optimization	2008/09/12
Level 3 Schematics	Rev. 1.0
VE538	4H.0H101.A01
Repair Optimization Service Training	Page 4 of 13

R : ~R4007
C : ~C4017

Downlink Audio Path _ 2-in-1 Speaker

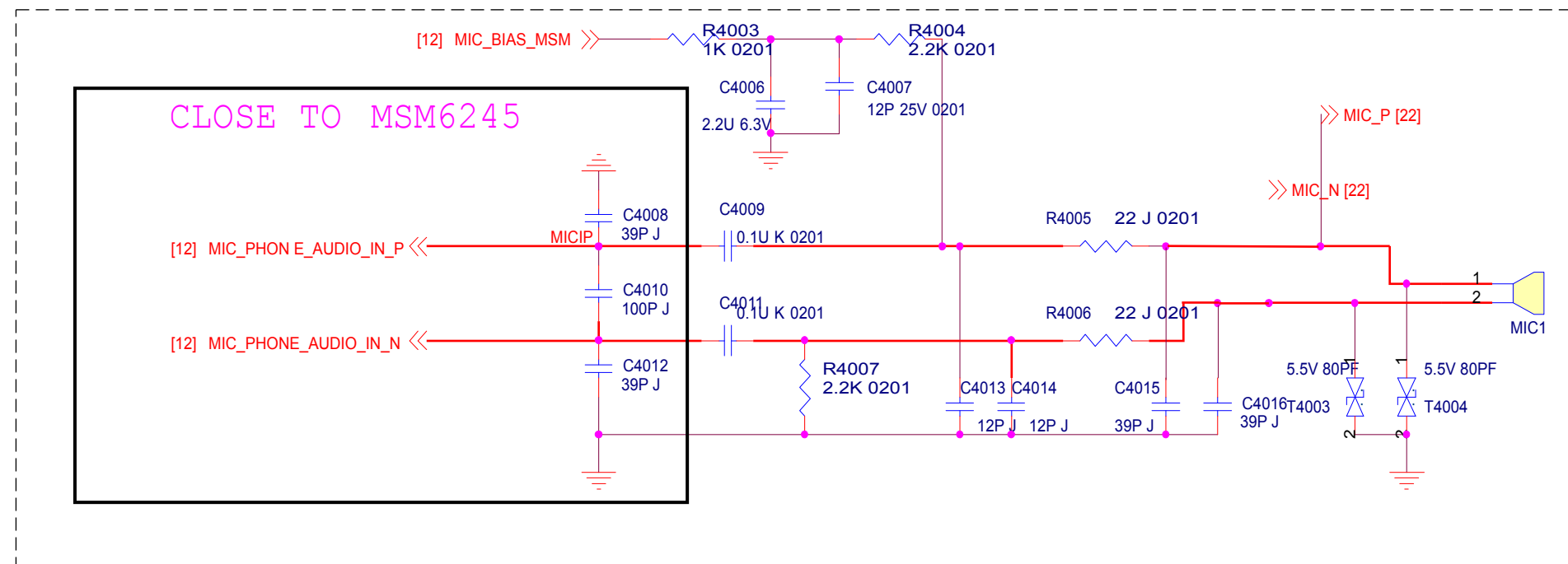
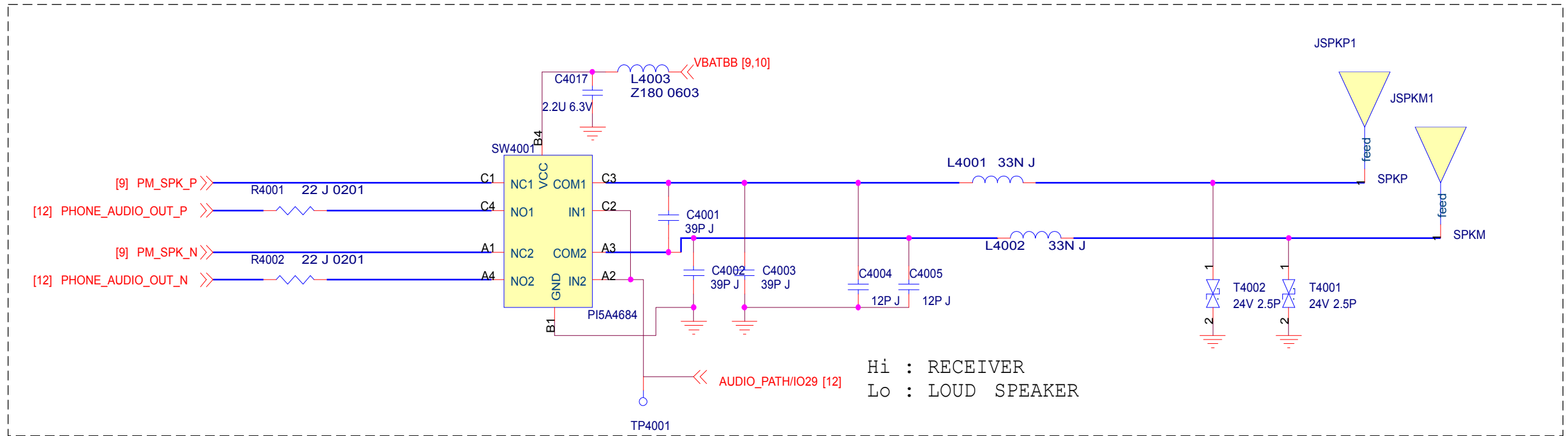

Uplink Audio Path _ Microphone

Repair Optimization Service Training
Level 3 Authorized

Service, Engineering & Optimization	2008/09/12
Level 3 Schematics	Rev. 1.0
VE538	4H.OH101.A01
Repair Optimization Service Training	Page 5 of 13

VE538

R : ~R4105
C : ~C4104

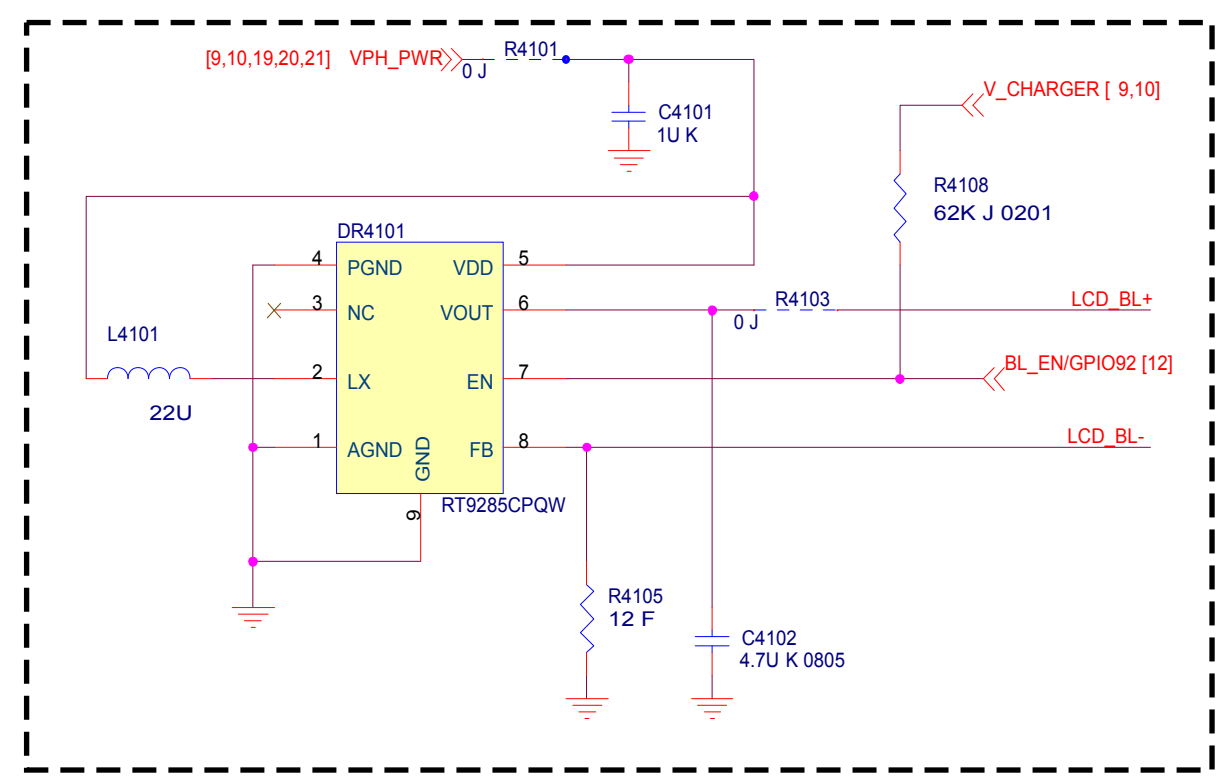

2.0" QVGA TM TFT LCD

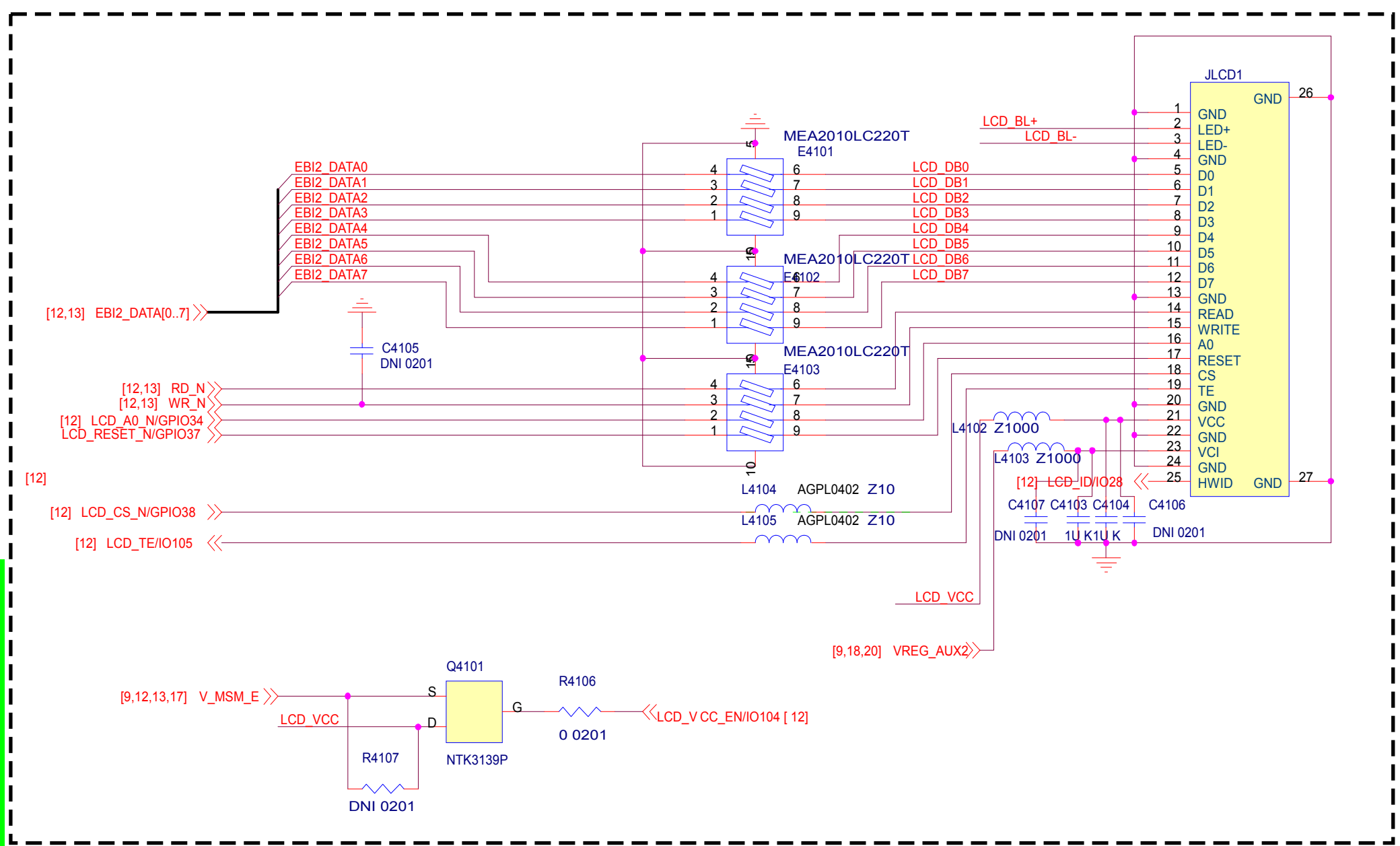

LED Driver

VE538



Service, Engineering & Optimization	2008/09/12
Level 3 Schematics	Rev. 1.0
VE538	4H.0H101.A01
Repair Optimization Service Training	Page 6 of 13

R : ~R4202
C : ~C4208

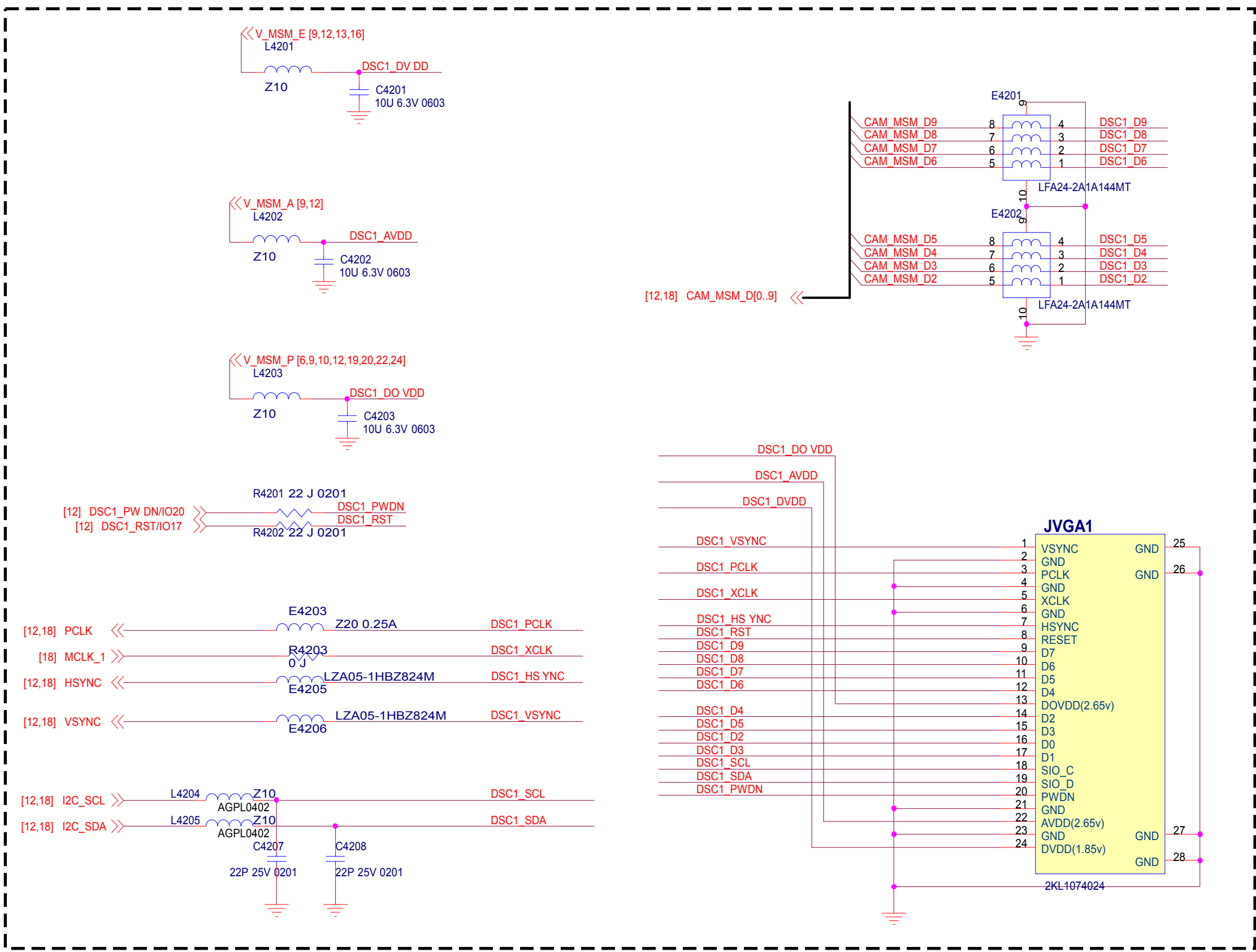

Camera_VGA

VE538

Repair Optimization Service Training
Level 3 Authorized

Service, Engineering & Optimization	2008/09/12
Level 3 Schematics	Rev. 1.0
VE538	4H.0H101.A01
Repair Optimization Service Training	Page 7 of 13

Camera_2.0Mp FF CMOS

R : ~R4306
C : ~C4306

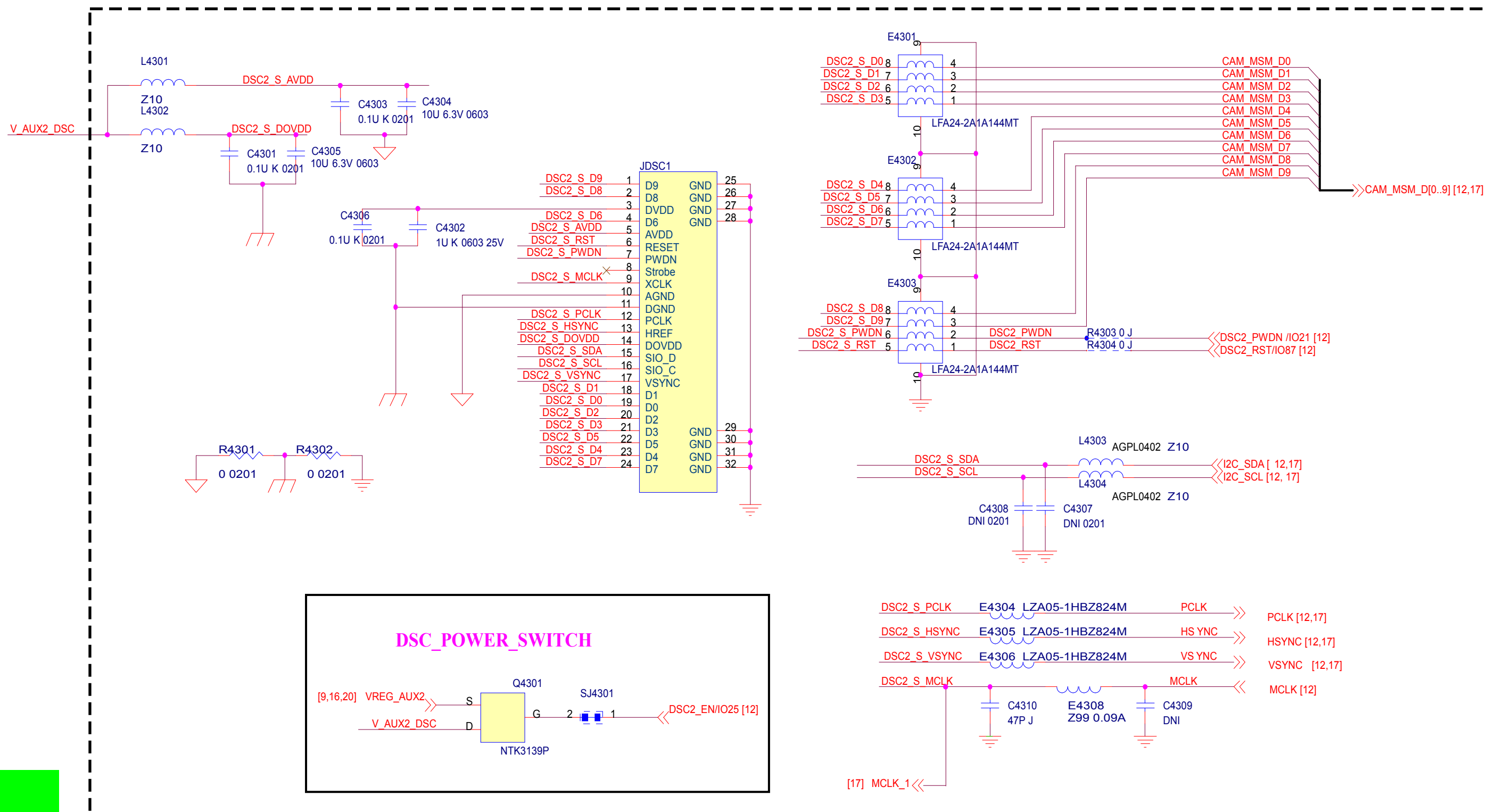

VE538



Service, Engineering & Optimization	2008/09/12
Level 3 Schematics	Rev. 1.0
VE538	4H.0H101.A01
Repair Optimization Service Training	Page 8 of 13

R : ~R4404
C : ~C4403

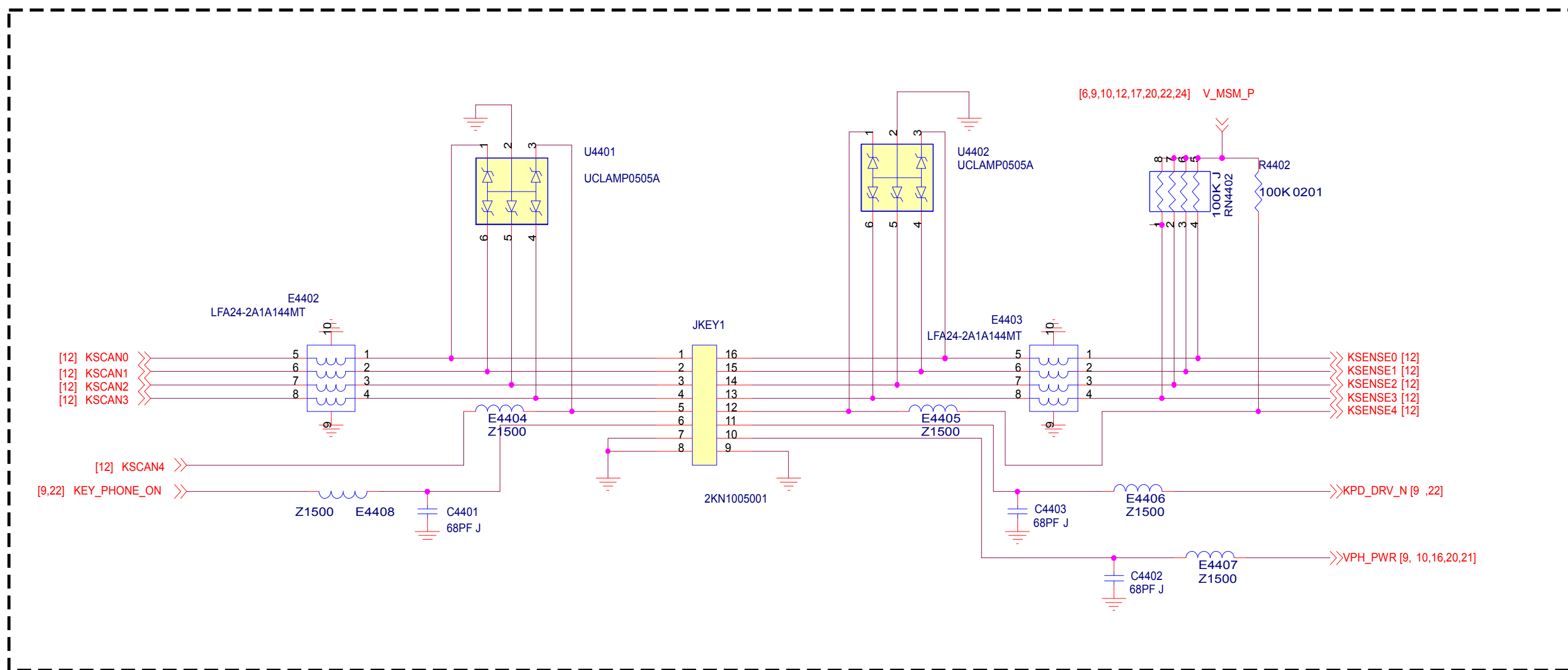

Keypad

VE538

**Repair Optimization
Service Training
Level 3 Authorized**

Service, Engineering & Optimization	2008/09/12
Level 3 Schematics	Rev. 1.0
VE538	4H.0H101.A01
Repair Optimization Service Training	Page 9 of 13

Mono\Stereo Mode Switch

Headset Power Switch

SEND/END Key Function

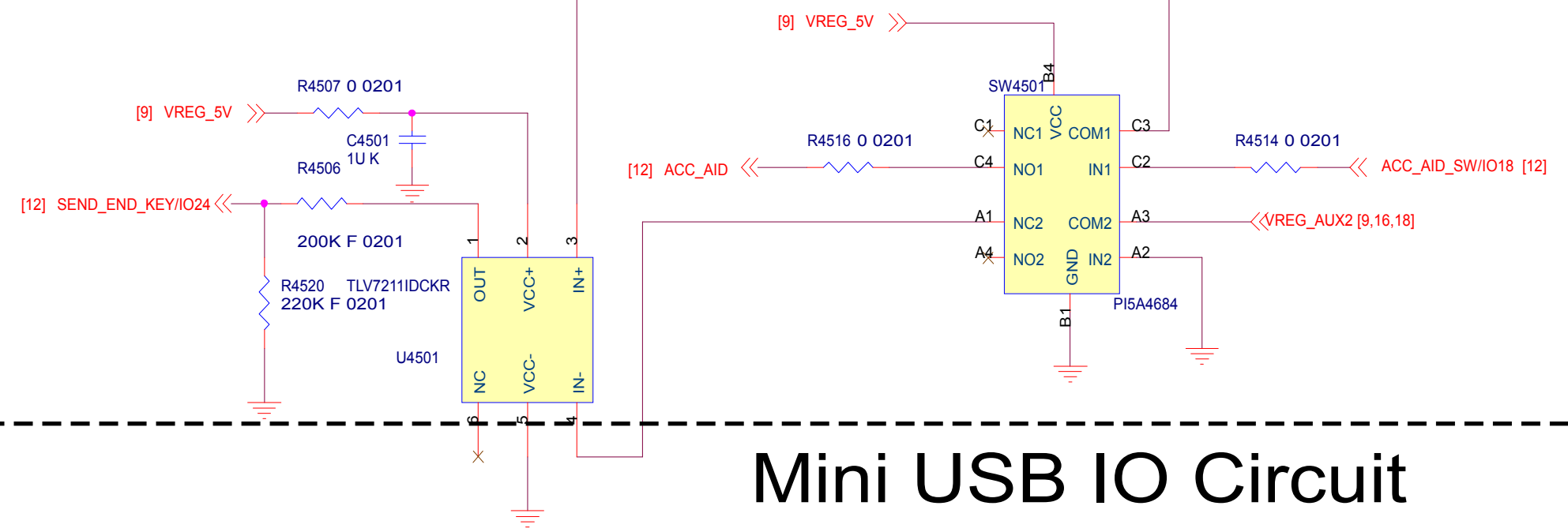
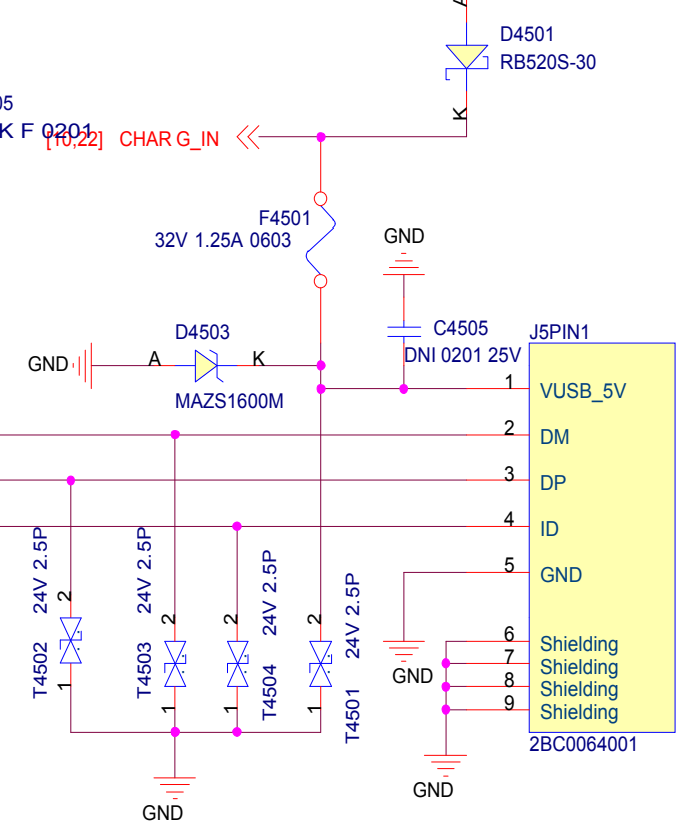
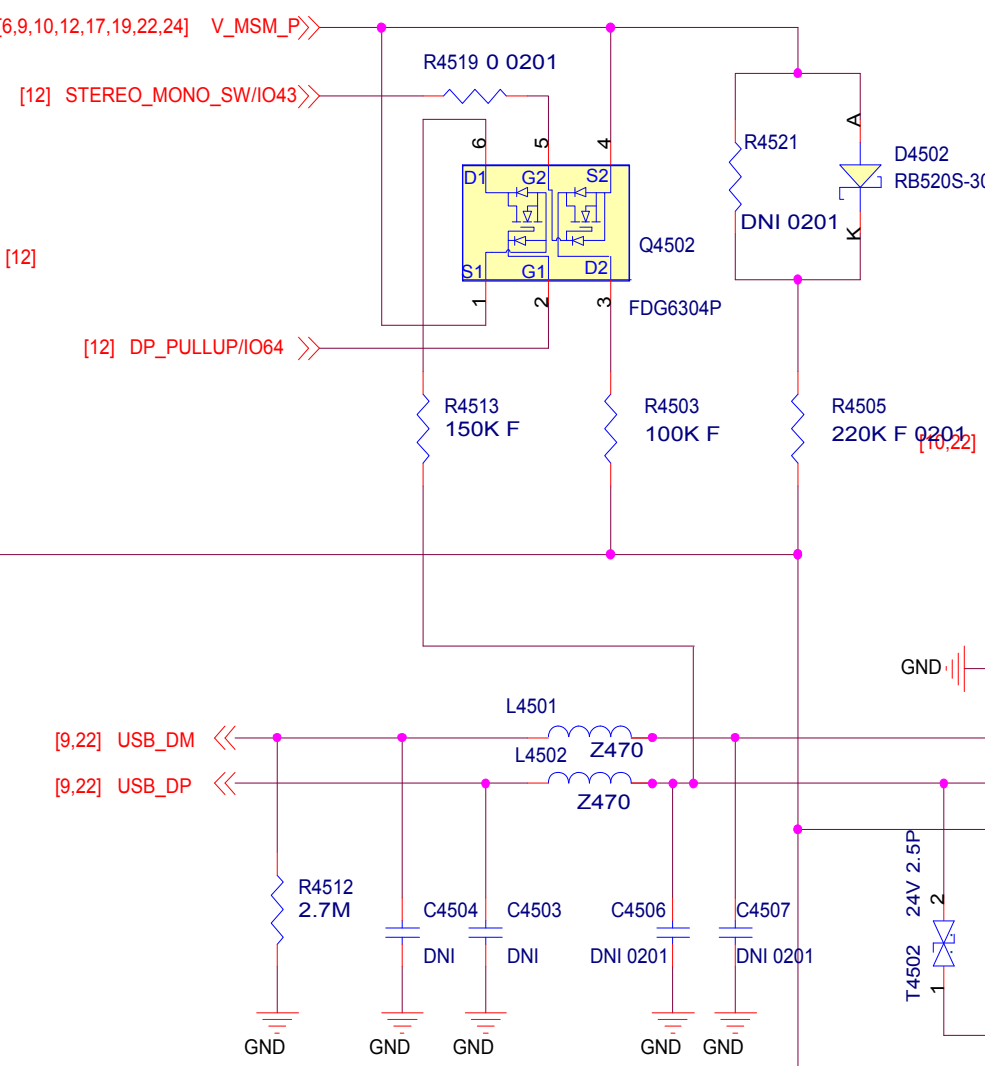
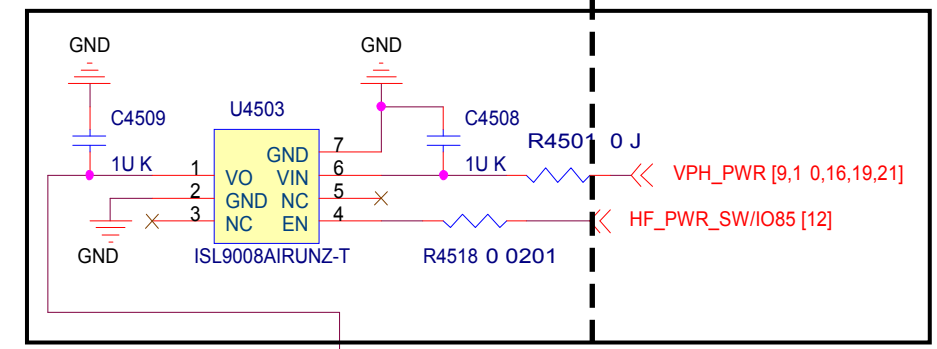
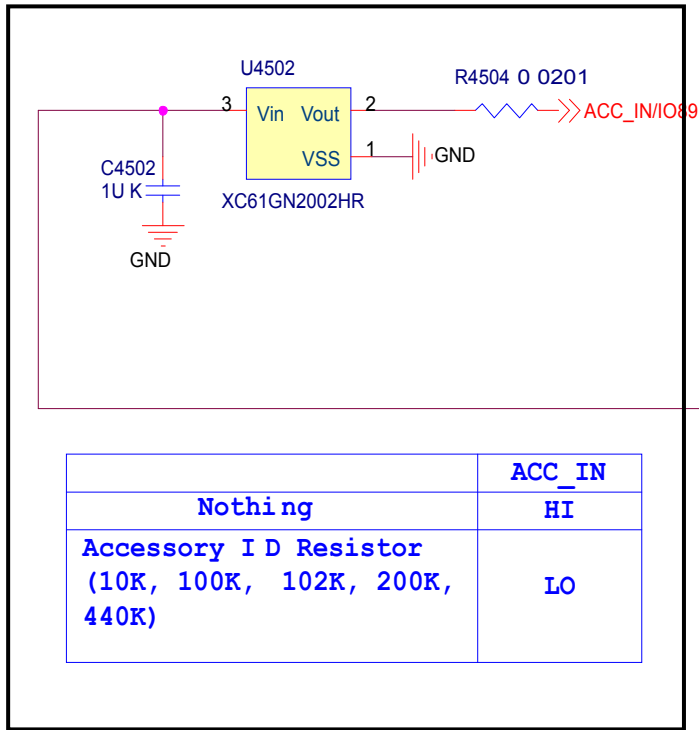

Mini USB IO Circuit



Service, Engineering & Optimization	2008/09/12
Level 3 Schematics	Rev. 1.0
VE538	4H.0H101.A01
Repair Optimization Service Training	Page 10 of 13

VE538

Charging Circuit

R : ~R2112
C : ~C2110

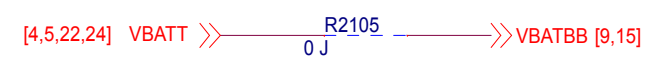
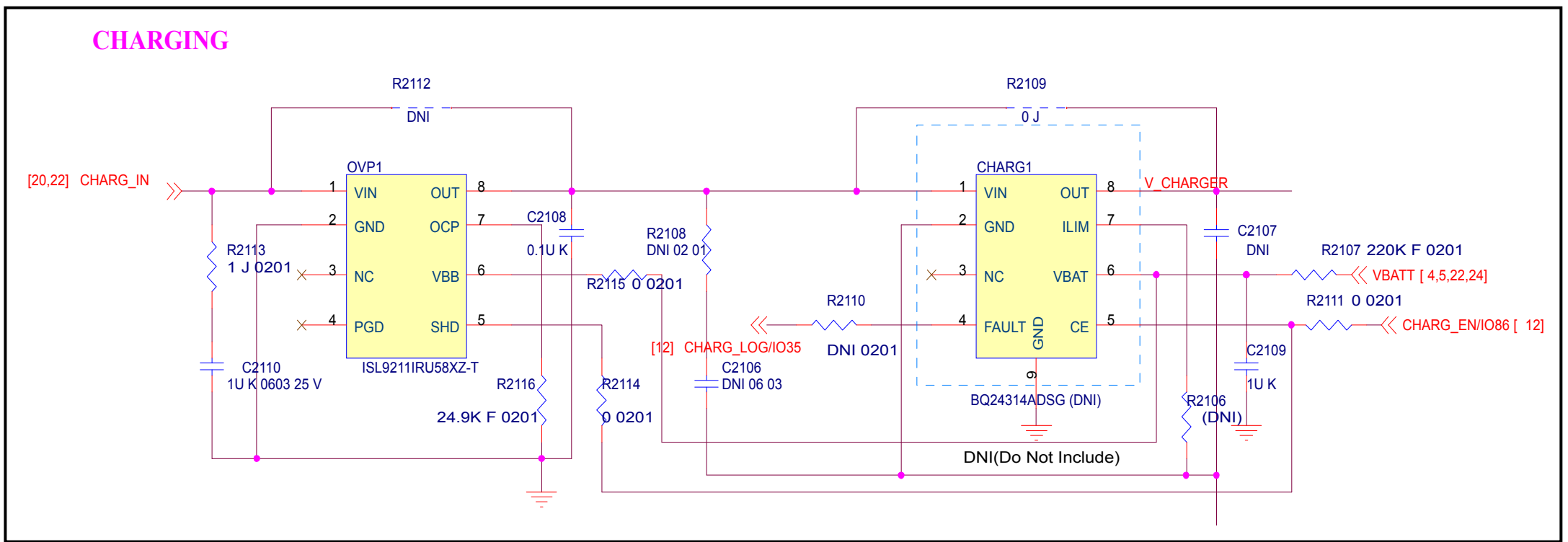
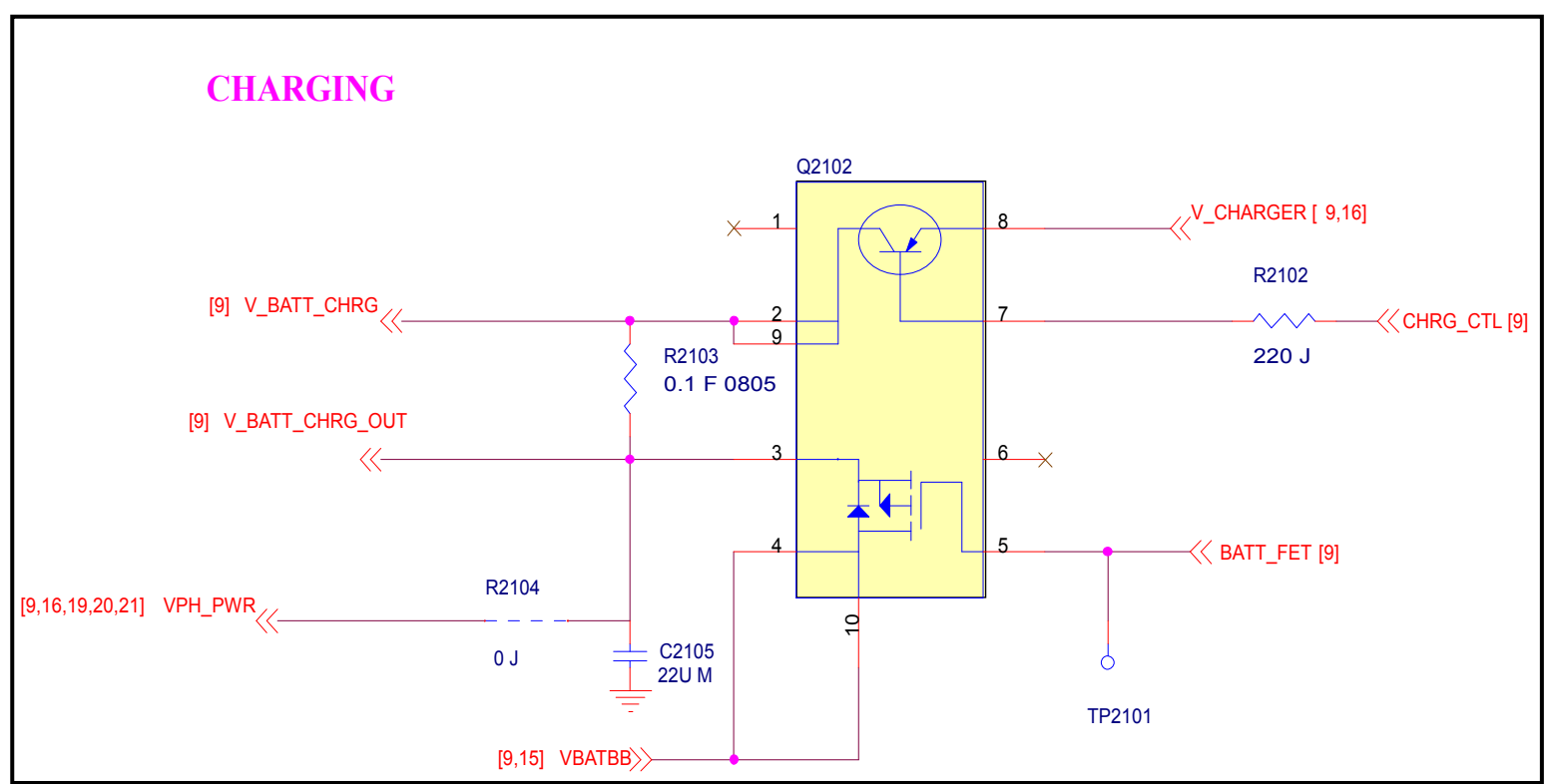
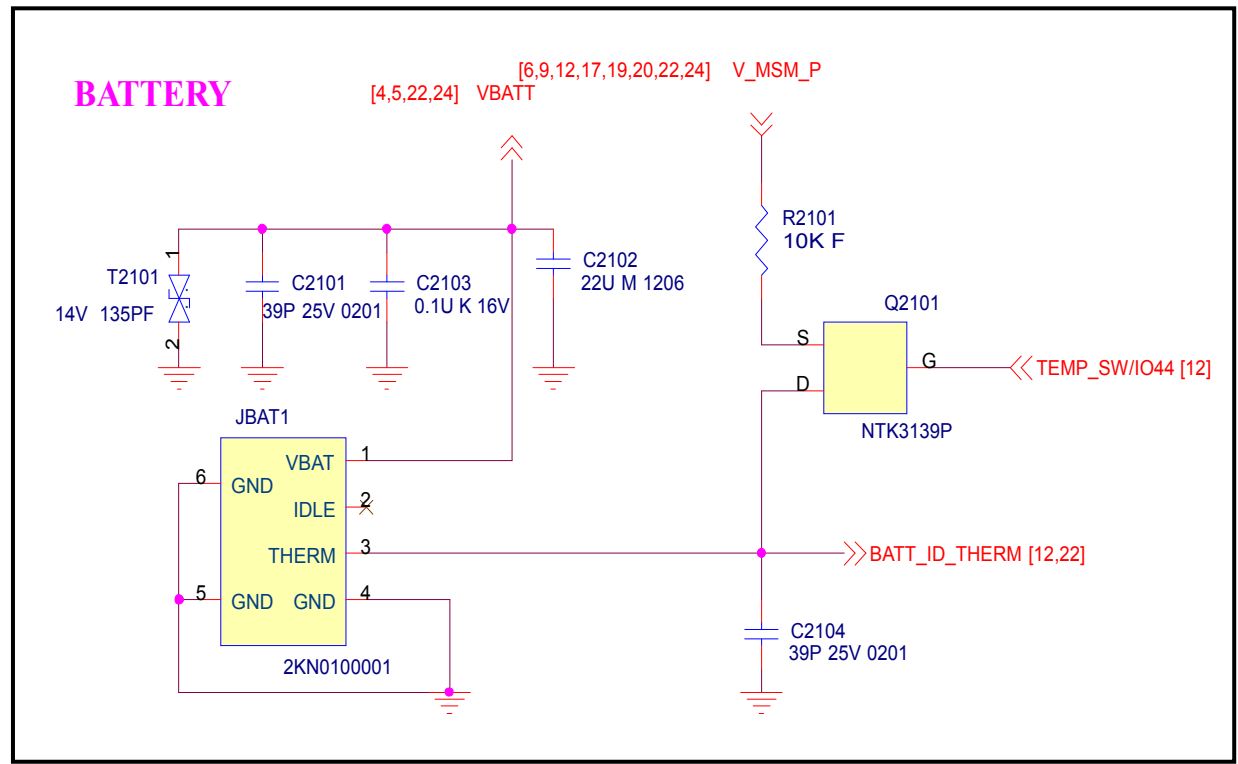

VE538

Repair Optimization Service Training
Level 3 Authorized

Service, Engineering & Optimization	2008/09/12
Level 3 Schematics	Rev. 1.0
VE538	4H.0H101.A01
Repair Optimization Service Training	Page 11 of 13

Micro SD

R : ~R4606
C : ~C4611

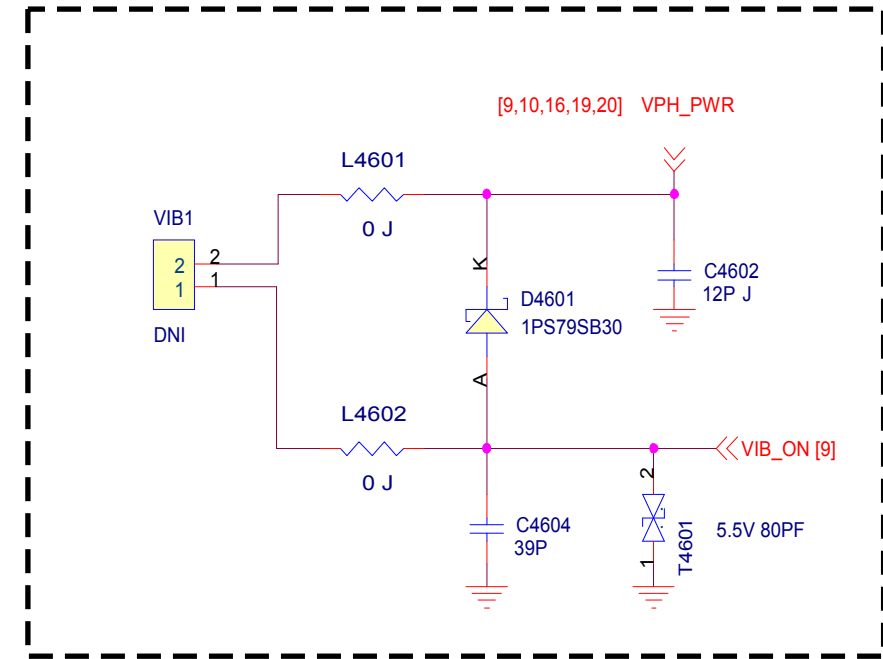
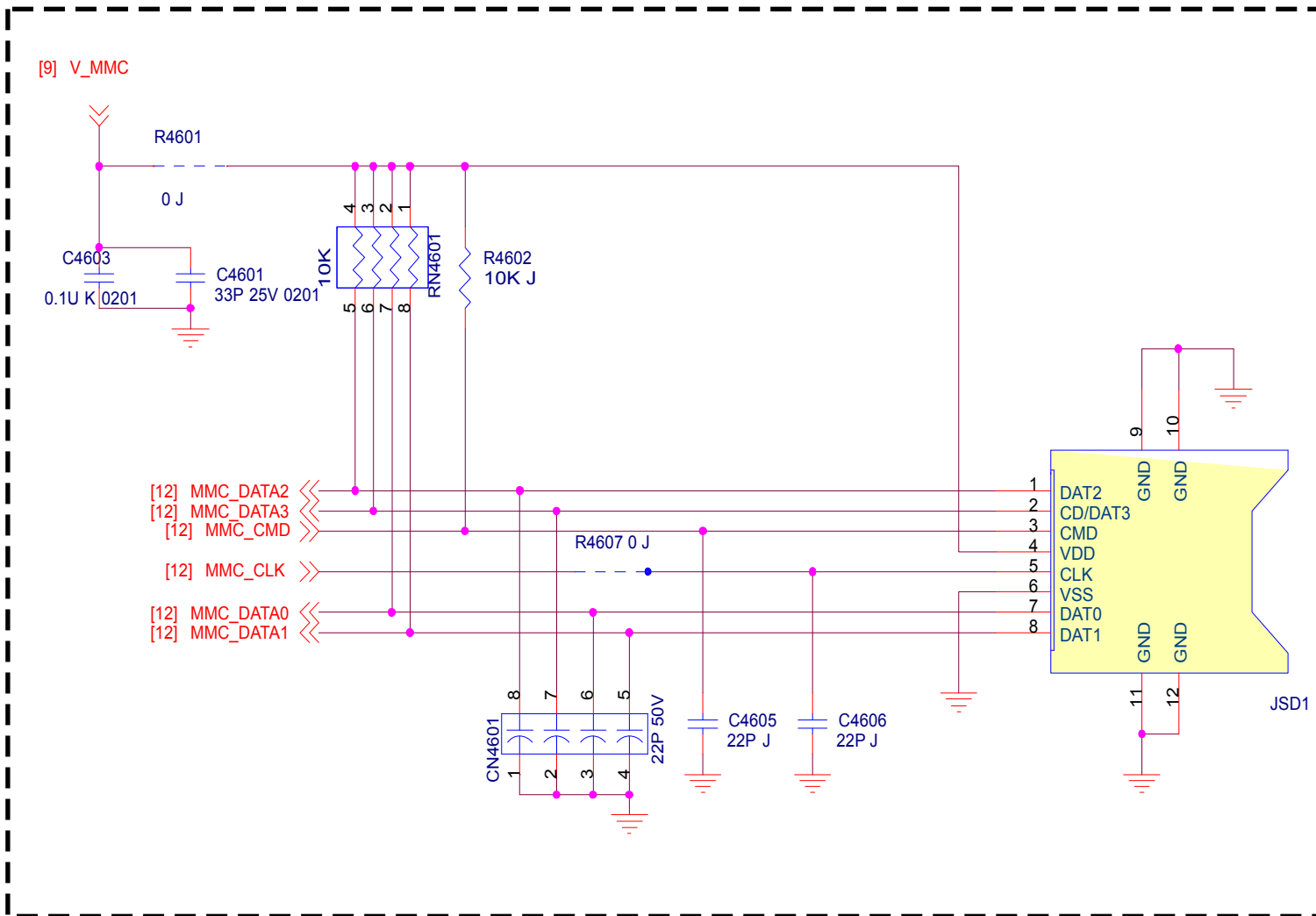

VIBRATOR

SIM

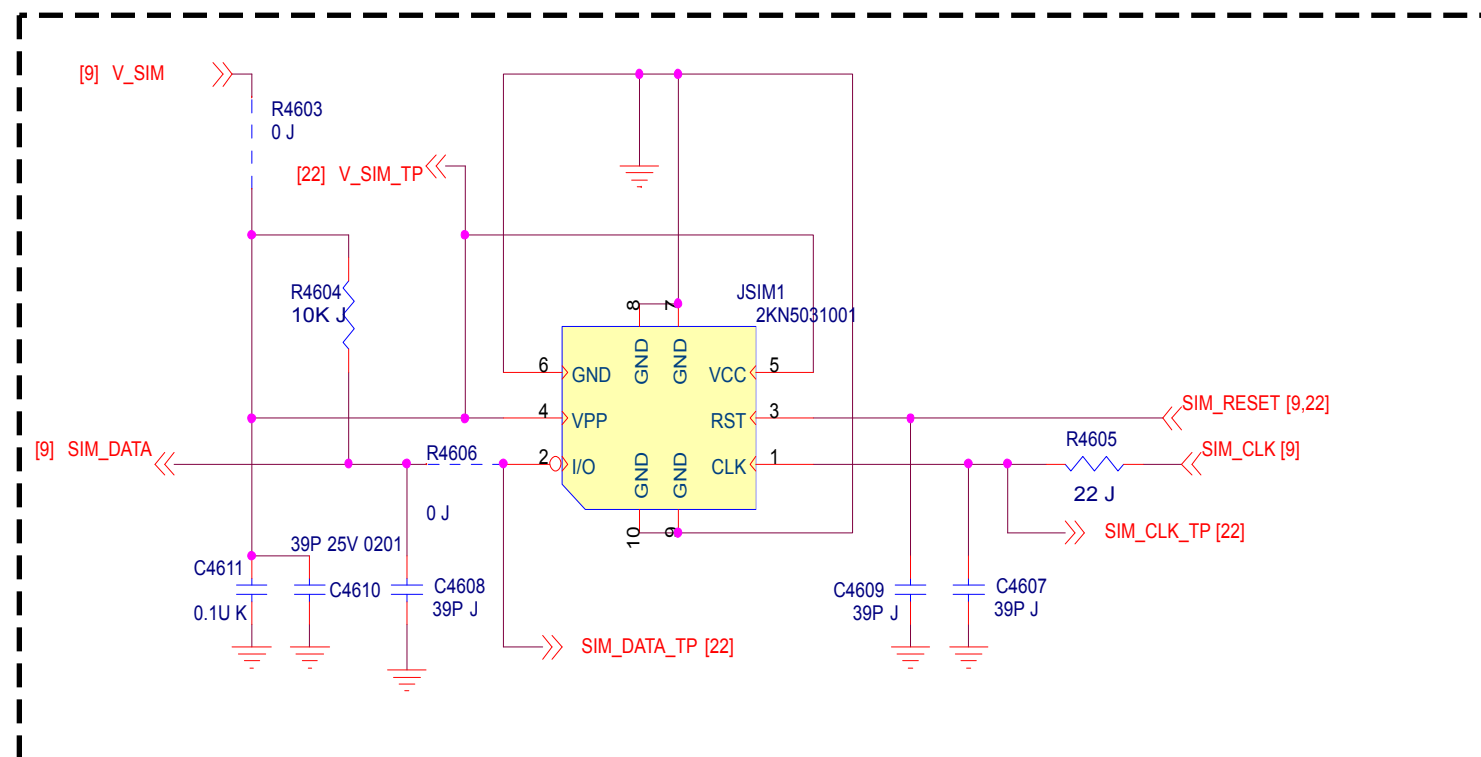

VE538

Repair Optimization Service Training
Level 3 Authorized

Service, Engineering & Optimization	2008/09/12
Level 3 Schematics	Rev. 1.0
VE538	4H.0H101.A01
Repair Optimization Service Training	Page 12 of 13

VE538

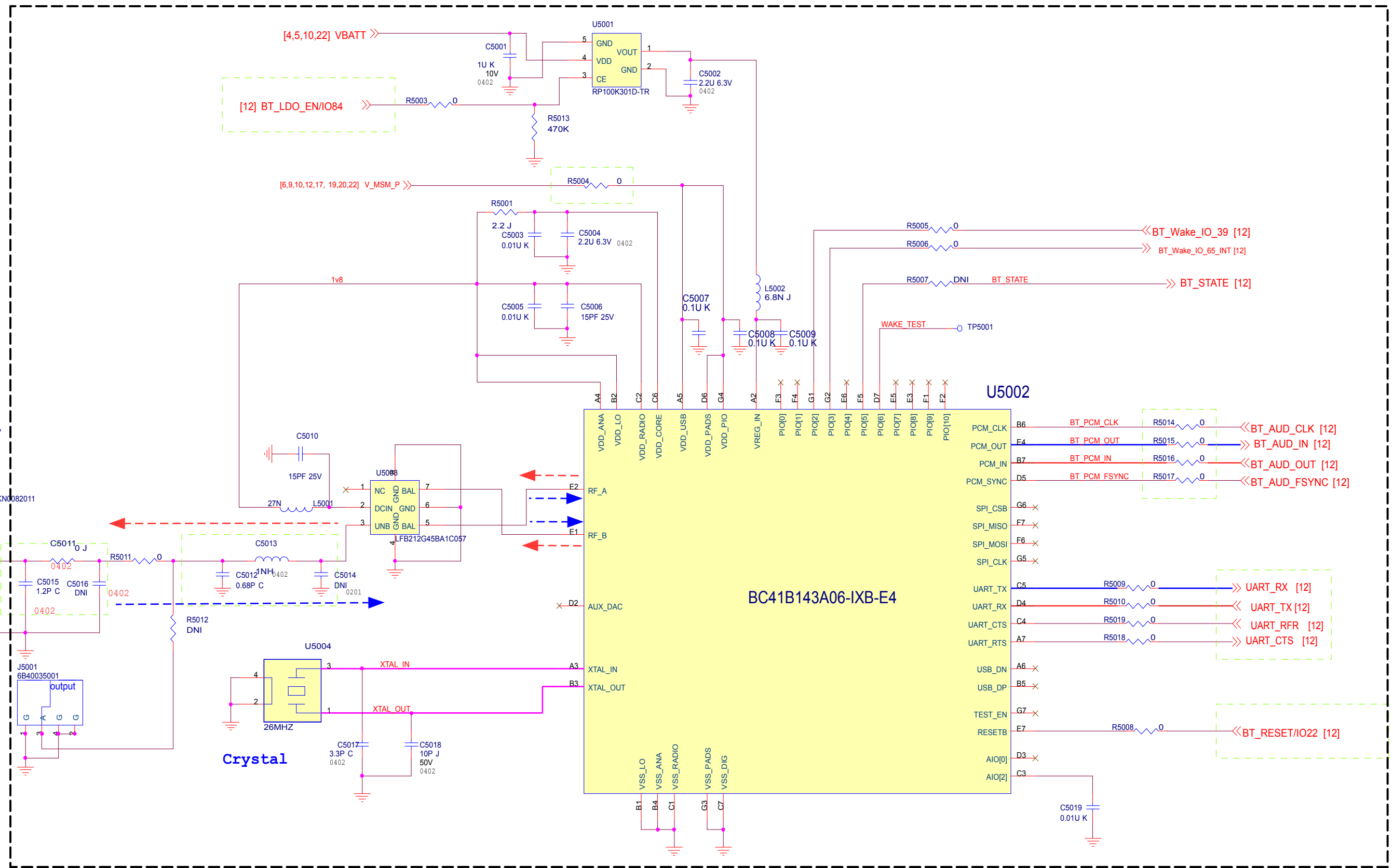

BlueTooth



Service, Engineering & Optimization	2008/09/12
Level 3 Schematics	Rev. 1.0
VE538	4H.0H101.A01
Repair Optimization Service Training	Page 13 of 13