

MOTOROLA CONFIDENTIAL PROPRIETARY
BASEBAND PROCESSOR

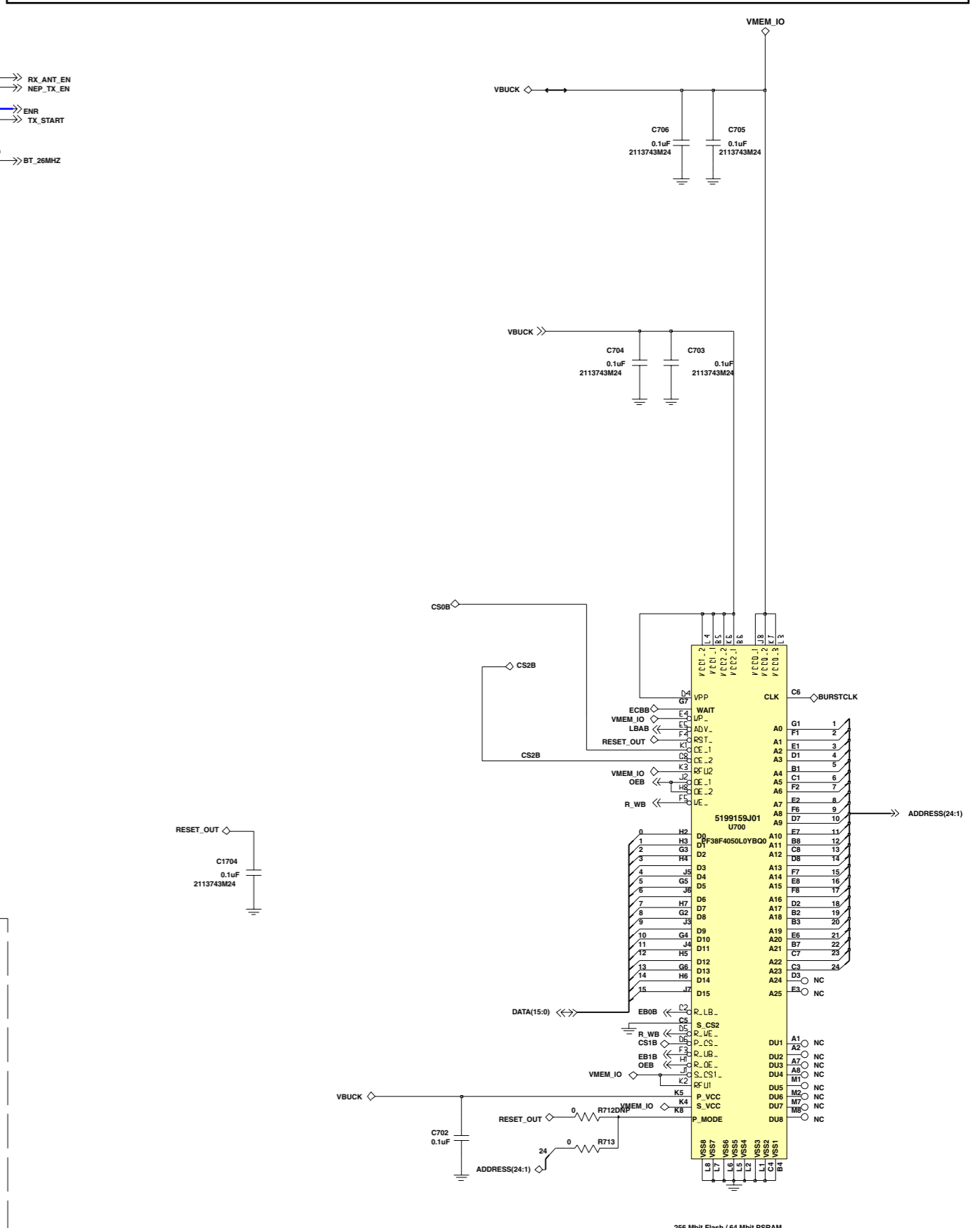
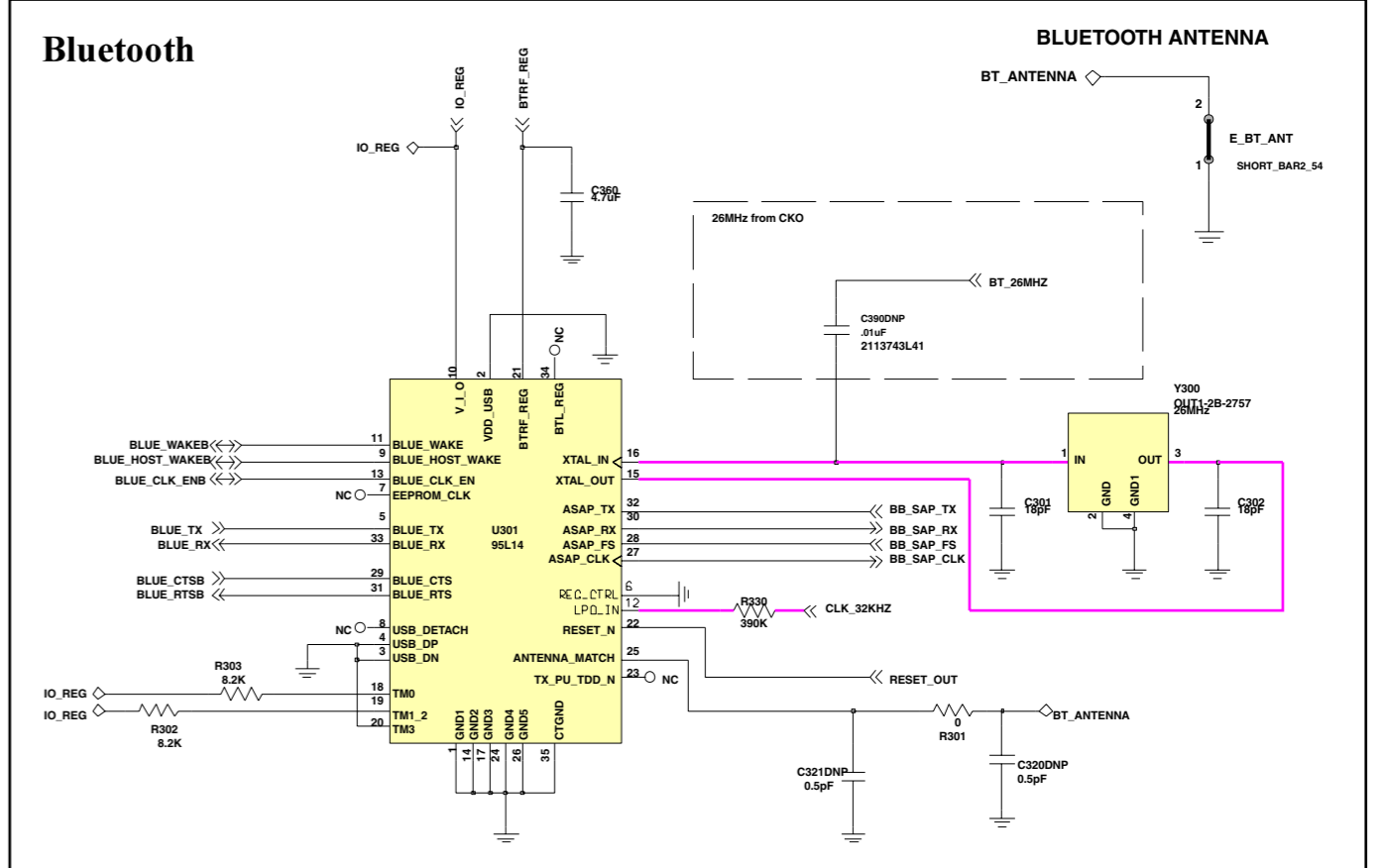
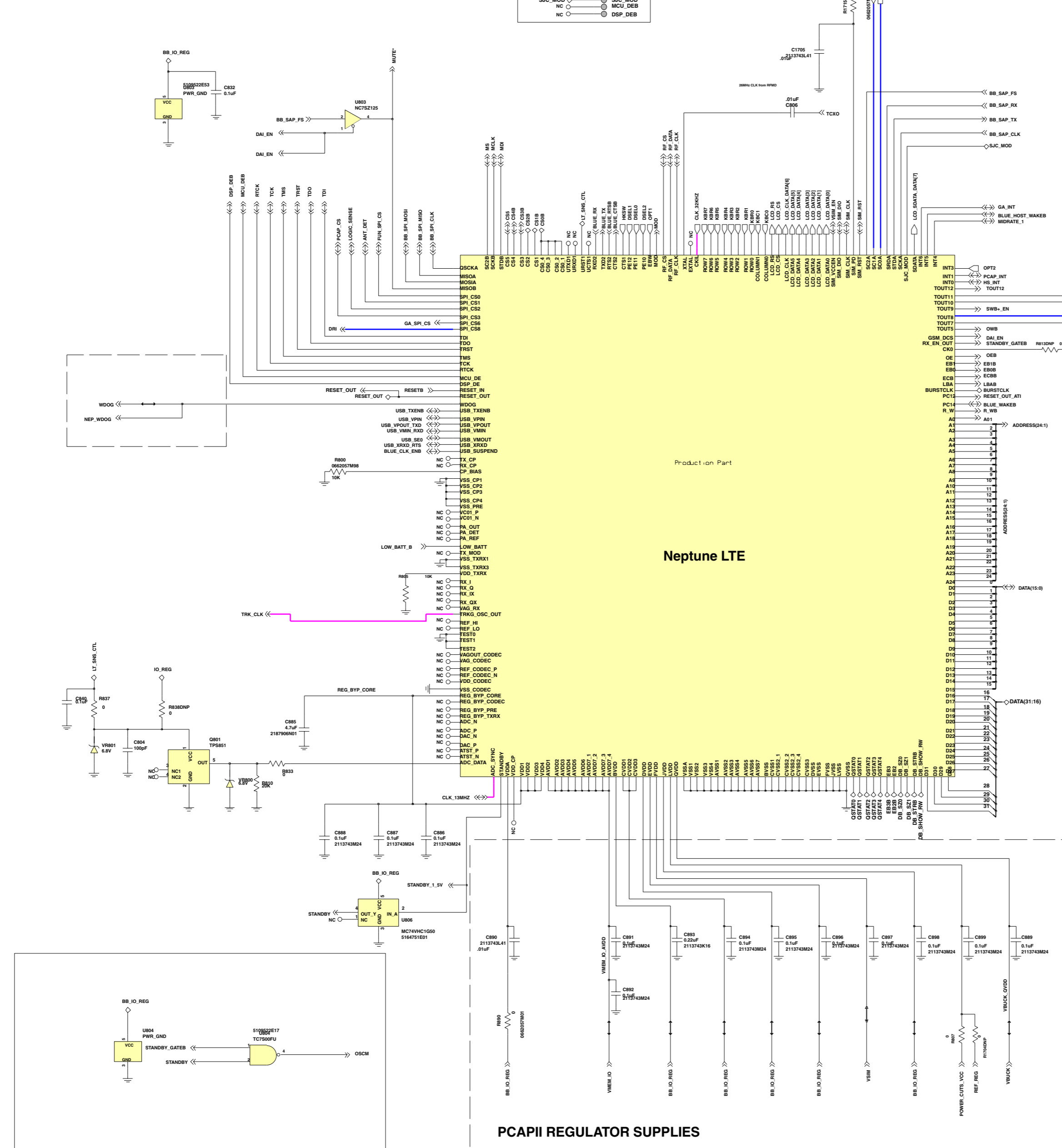

V635

Service Engineering
& Optimization
Level 3 Authorized

GSM SERVICE SUPPORT GROUP	2004.11.26
Level 3 Schematics	Rev. 1.0
V635	8488789V_01_P3C
Alexander Buehler, Michael Hansen	Page 1 of 5

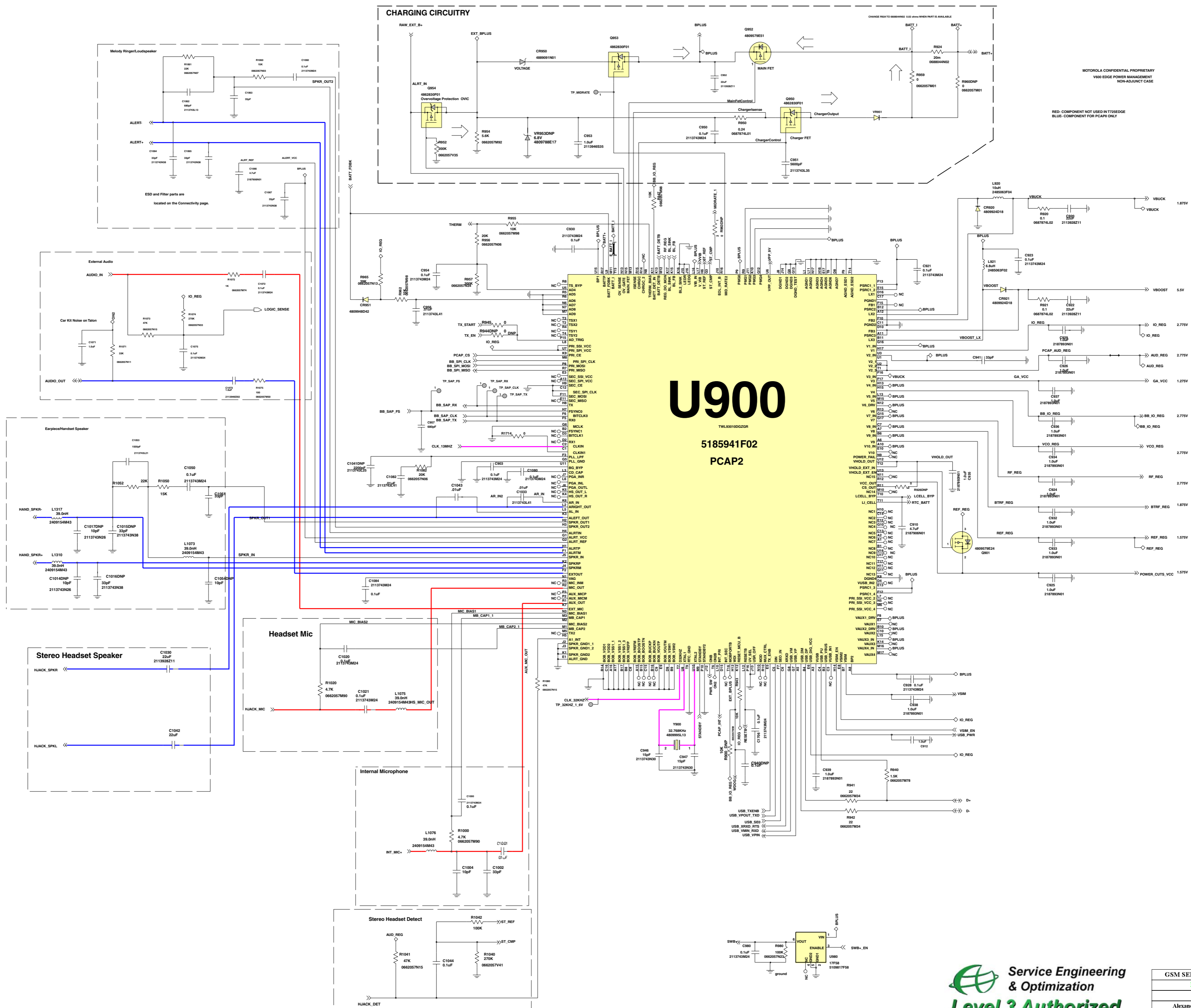

MOTOROLA CONFIDENTIAL PROPRIETARY
CONNECTIVITY

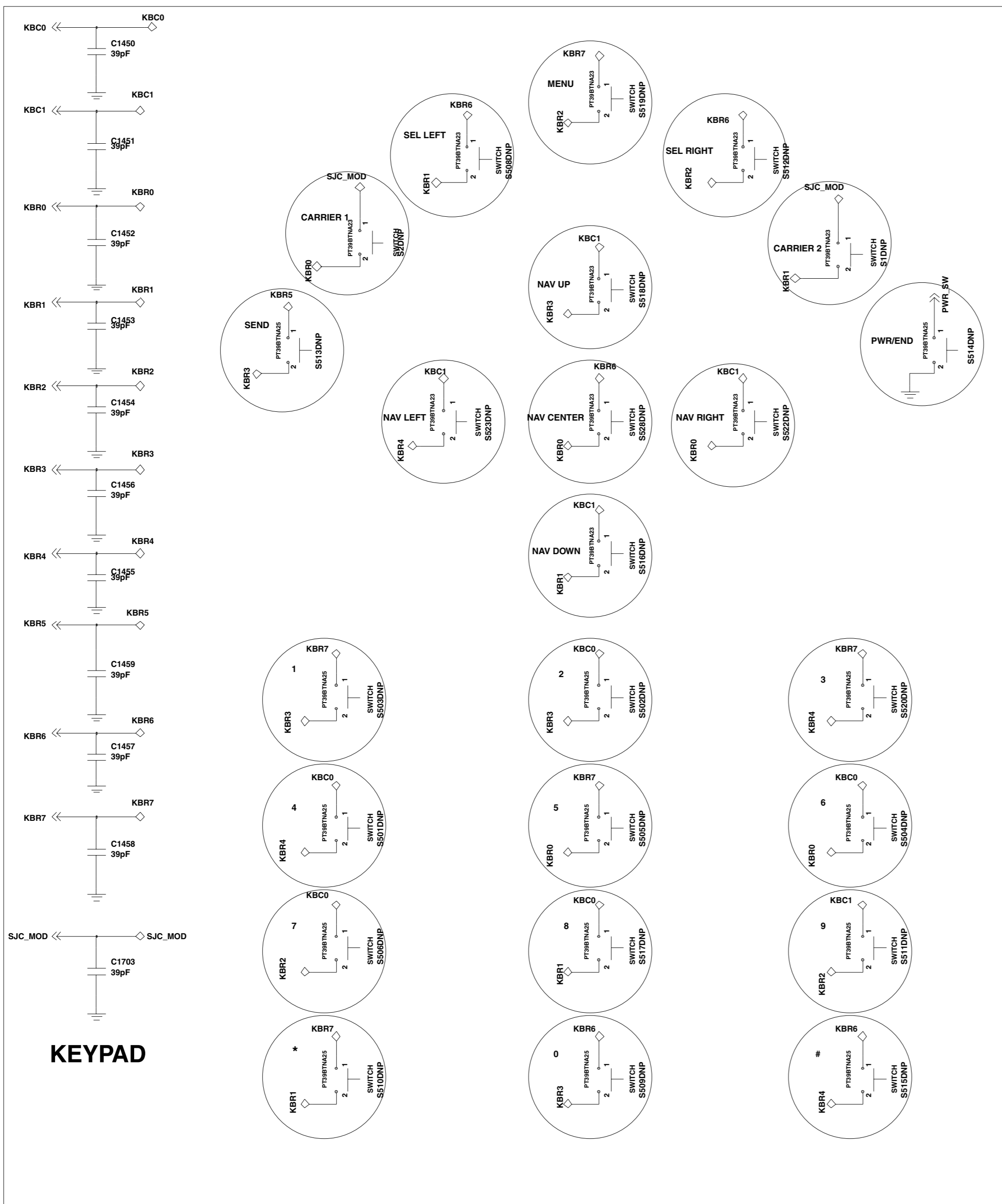

KEYPAD

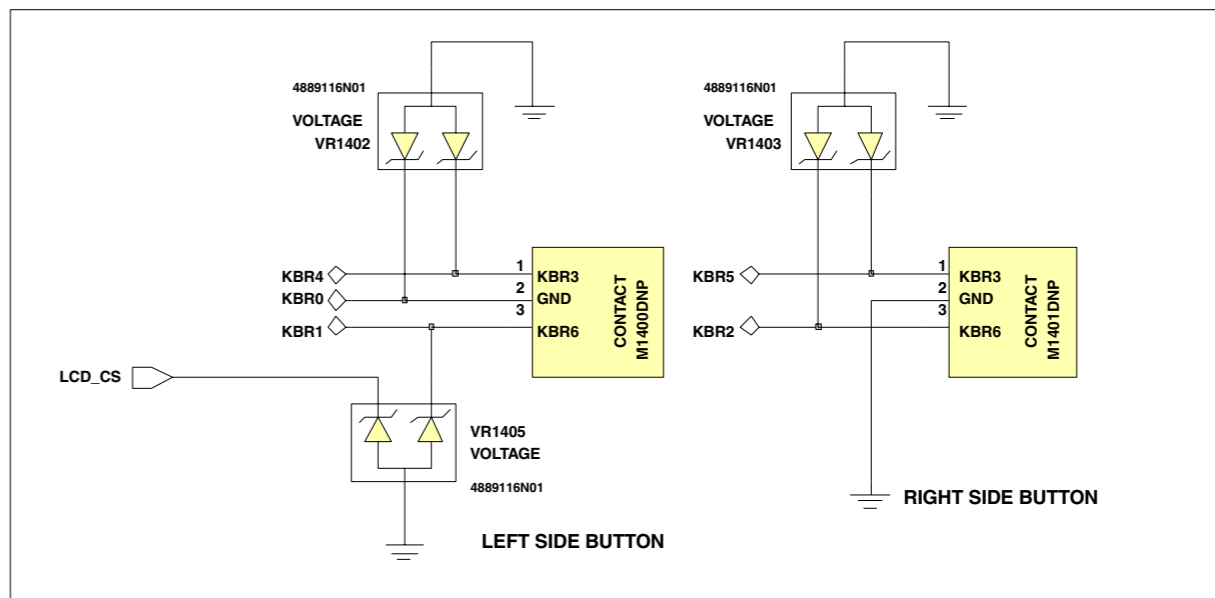

SIDE KEYS

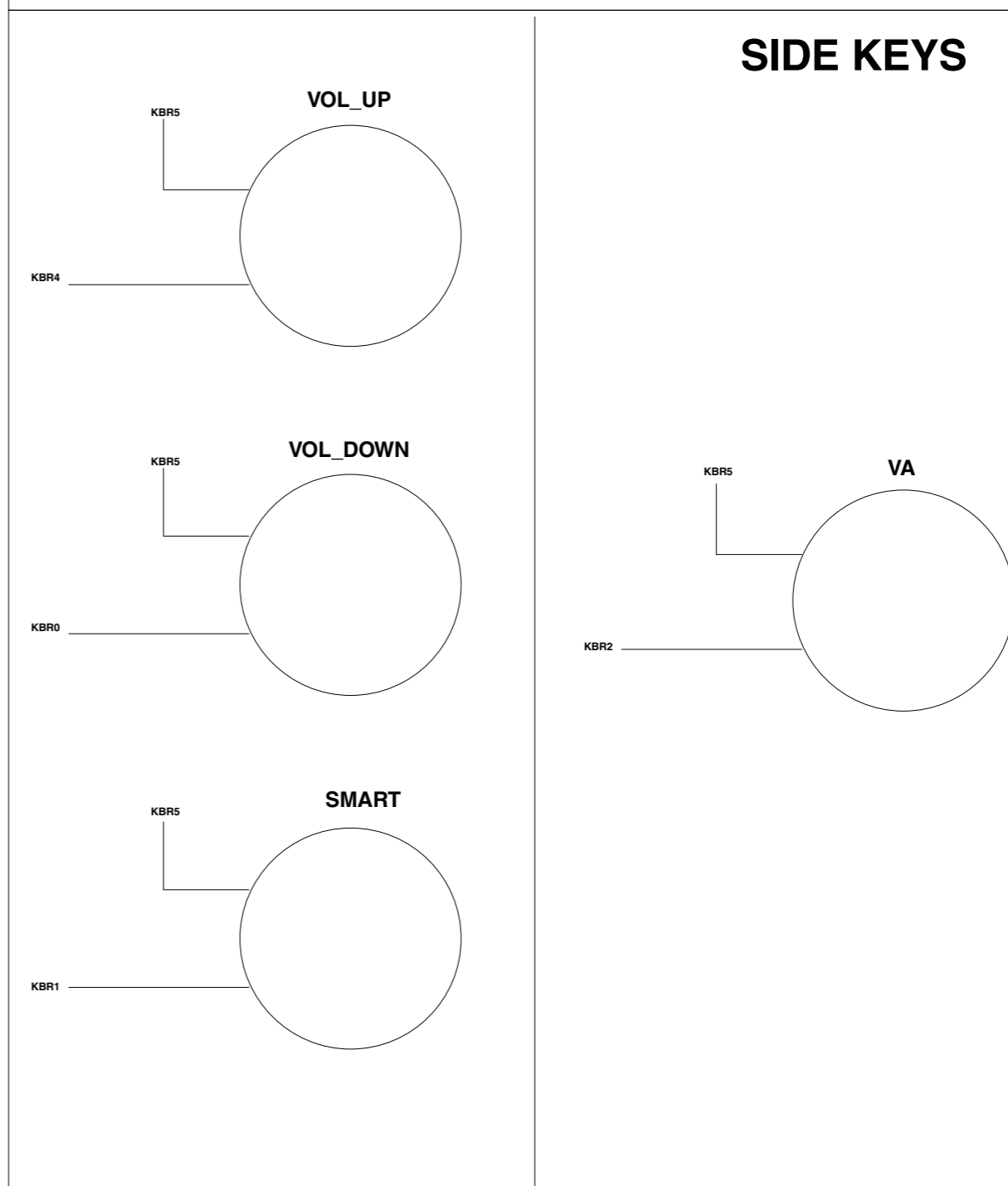

Mylar GND connections for ESD

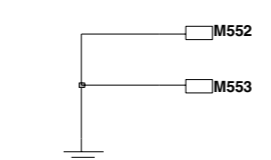

V600 DISPLAY CONNECTOR

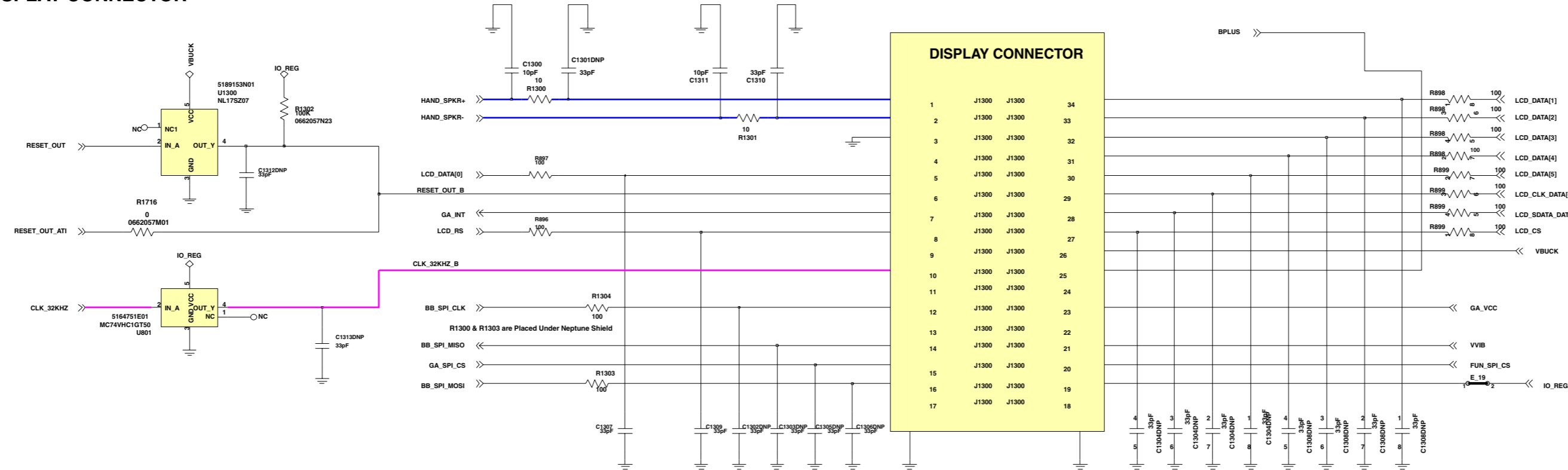

Stereo Headset Jack

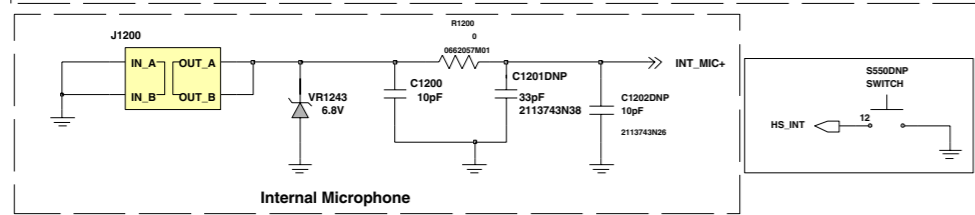
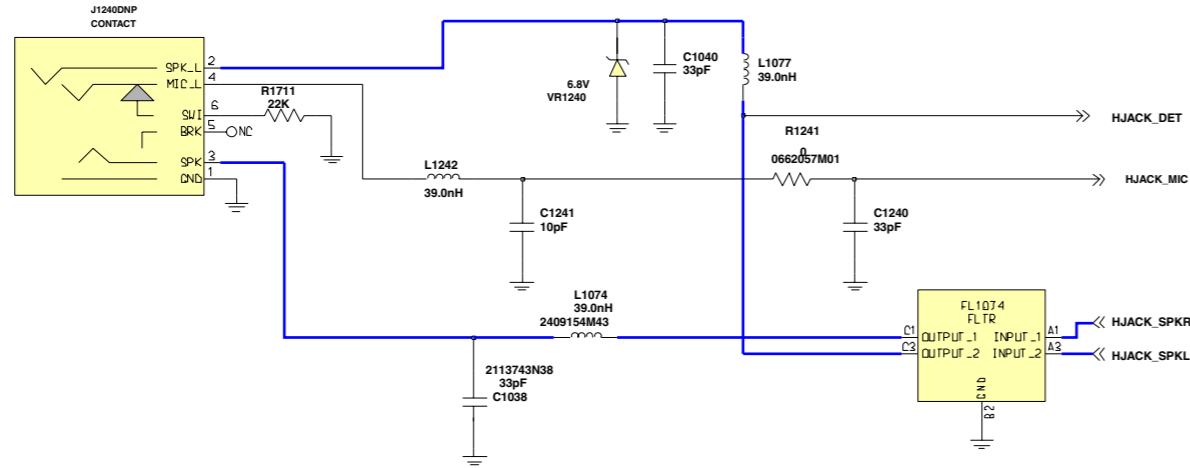

SIM BLOCK

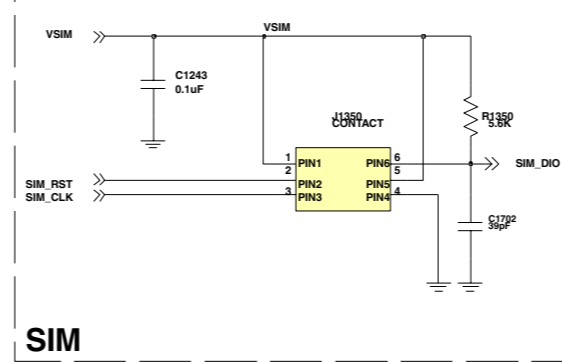

RTC Battery Connector

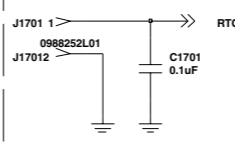

SIM

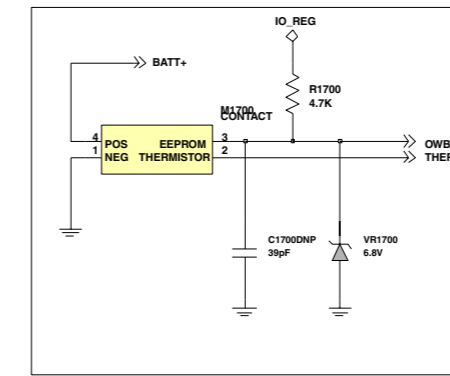
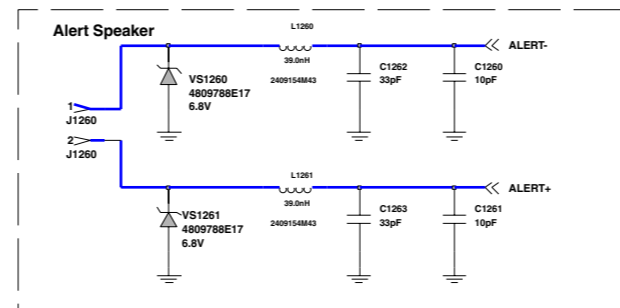

Accessory Connector CE Connector (0987636K06)

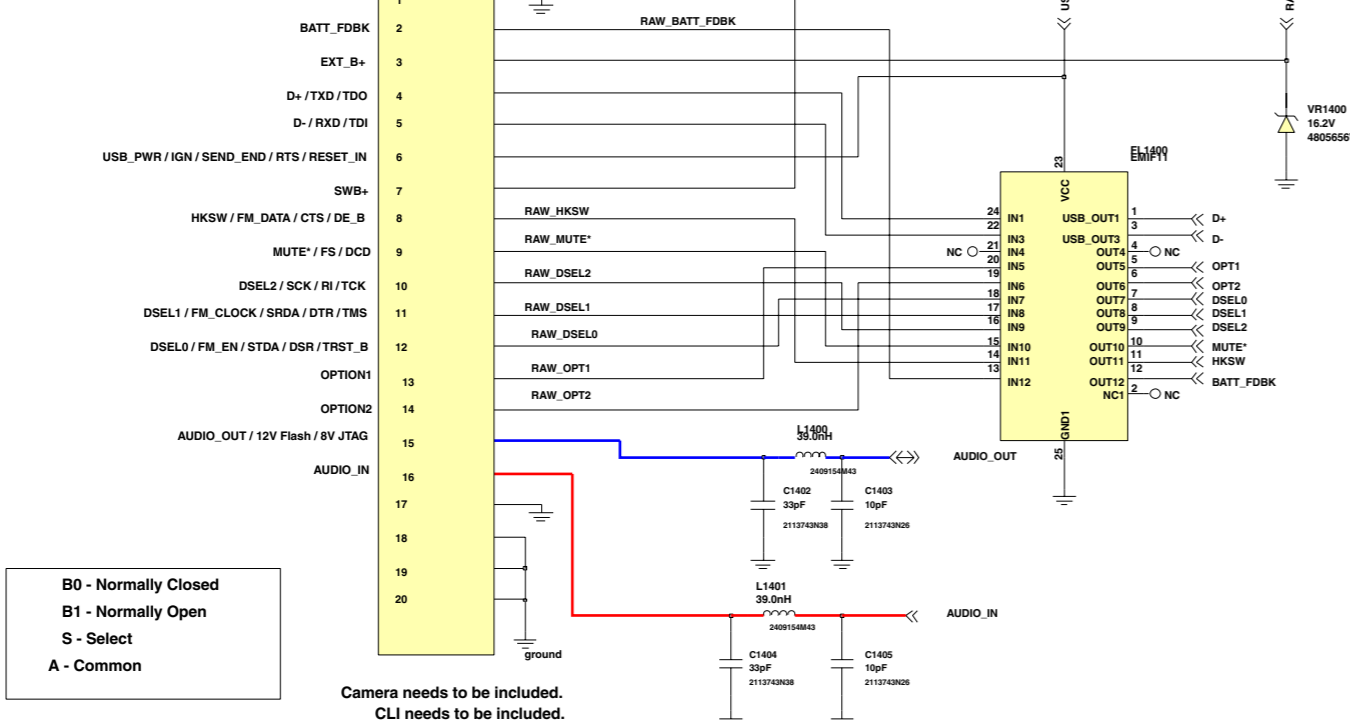

B0 - Normally Closed
B1 - Normally Open
S - Select
A - Common

Camera needs to be included.
CLI needs to be included.

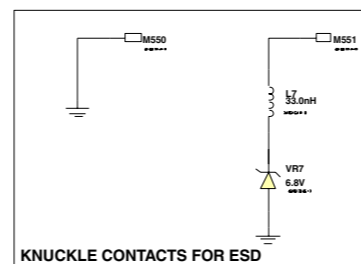
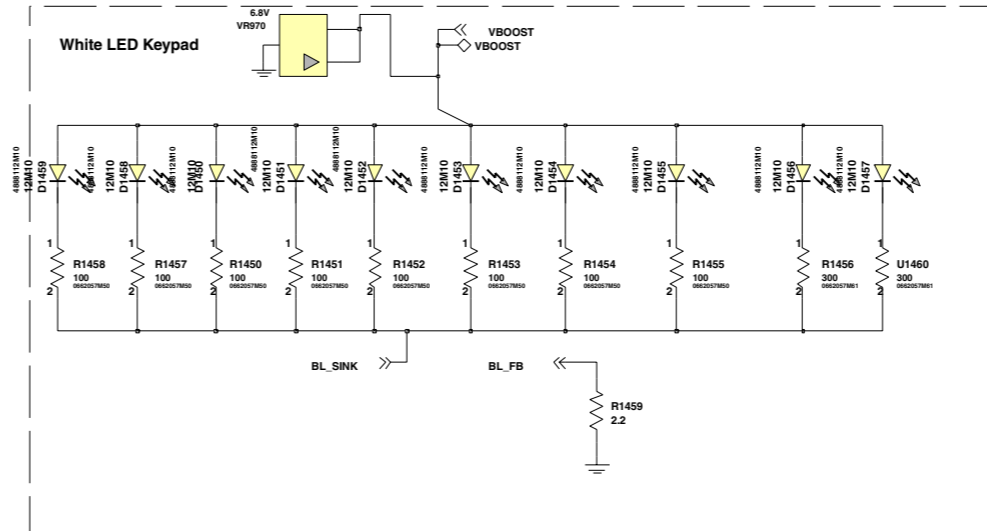

V635

Service Engineering & Optimization
Level 3 Authorized

GSM SERVICE SUPPORT GROUP	2004.11.26
Level 3 Schematics	Rev. 1.0
V635	8488789Y01_P3C
Alexander Buehler, Michael Hansen	Page 4 of 5

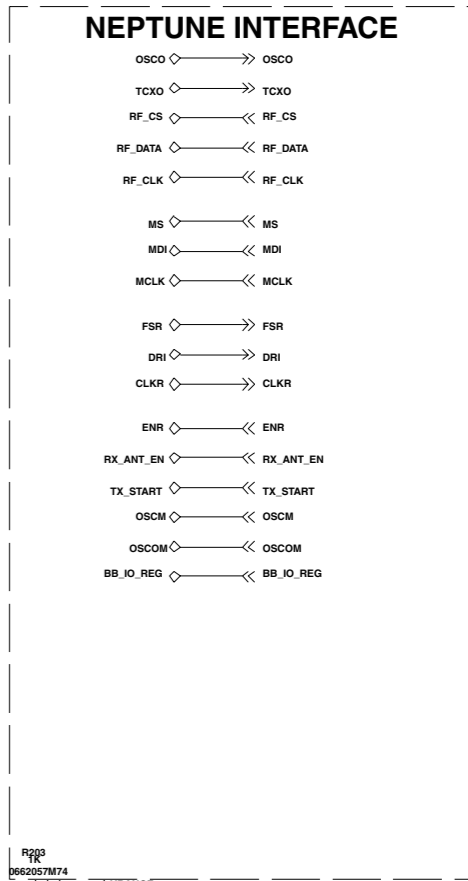
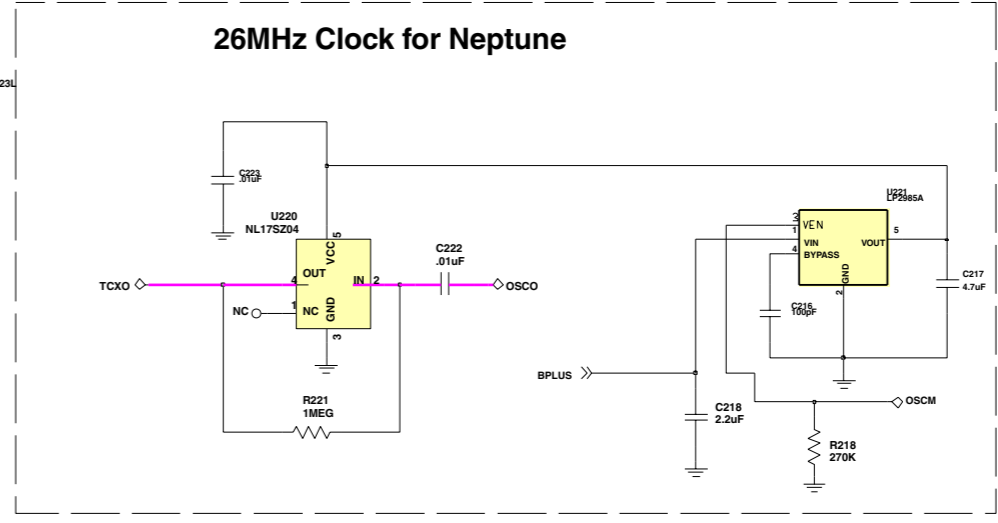
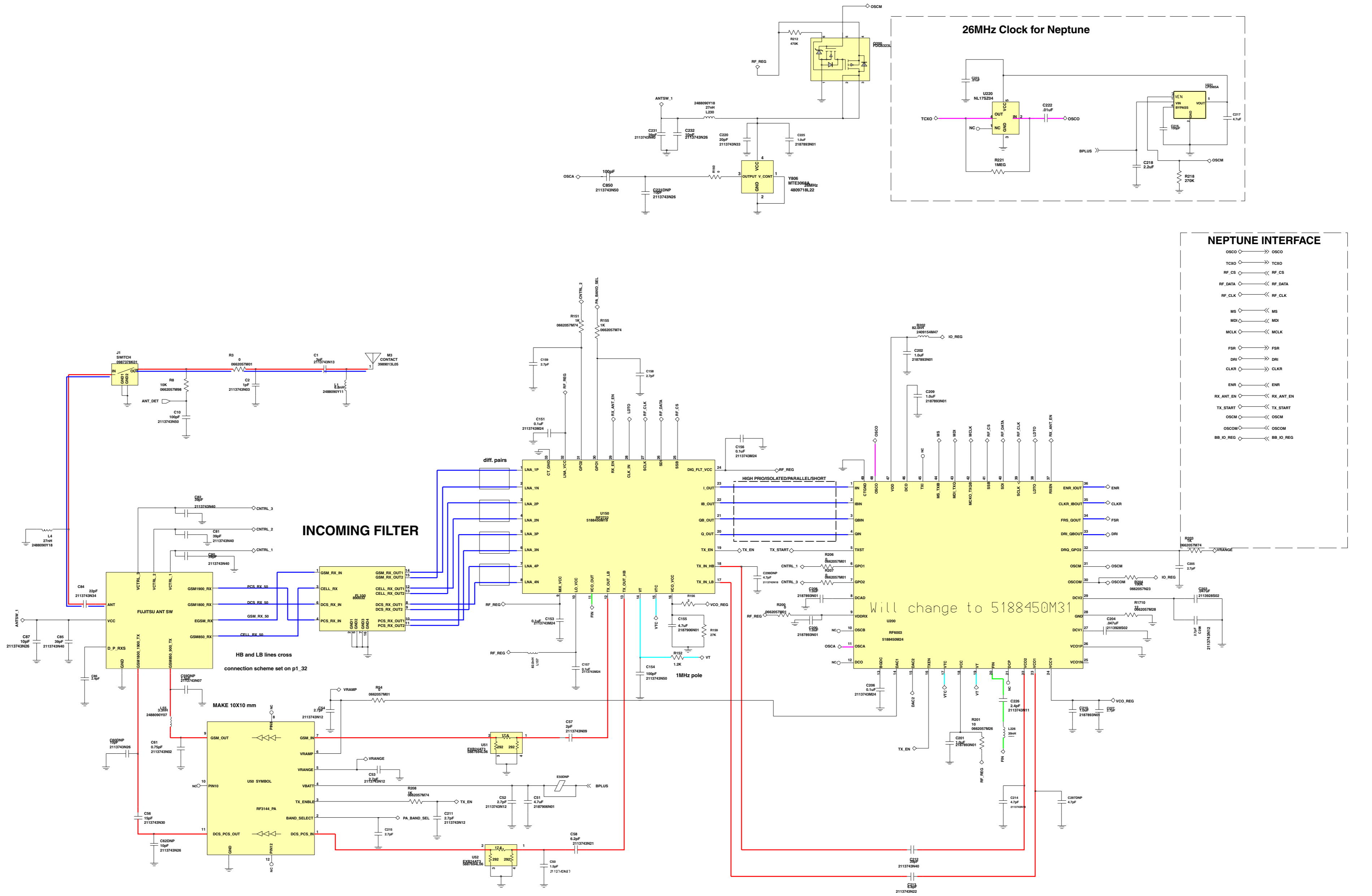

Will change to 5188450M31