

MOTOROLA CONFIDENTIAL PROPRIETARY
BASEBAND PROCESSOR

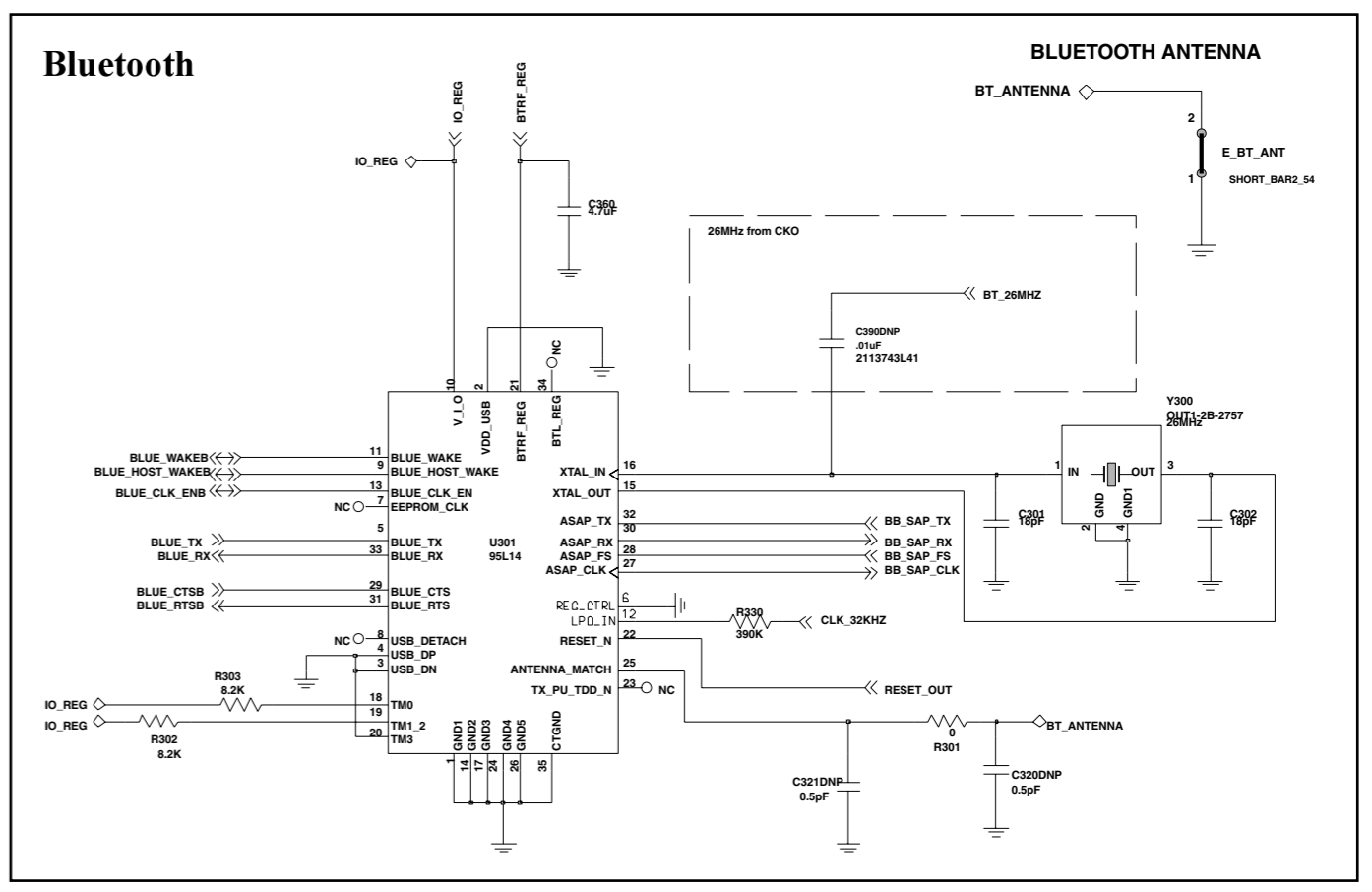
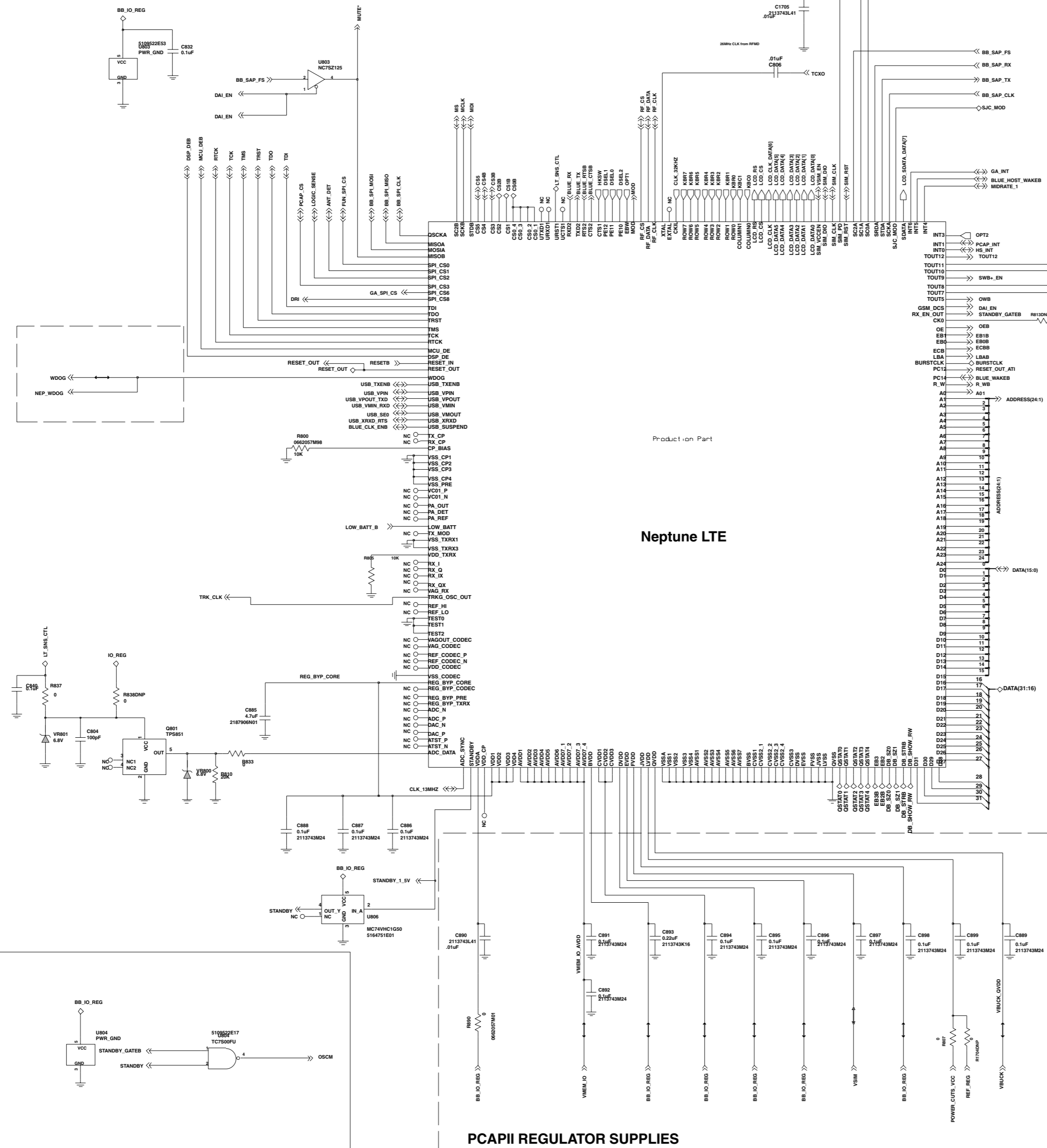

V635

Service Engineering
& Optimization
Level 3 Authorized

GSM SERVICE SUPPORT GROUP	2004.11.26
Level 3 Schematics	Rev. 1.0
V635	84887891_01_P3C
Alexander Buehler, Michael Hansen	Page 1 of 5

MOTOROLA CONFIDENTIAL PROPRIETARY
CONNECTIVITY

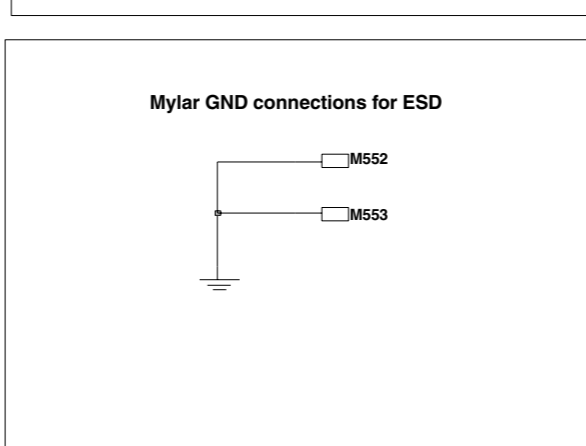
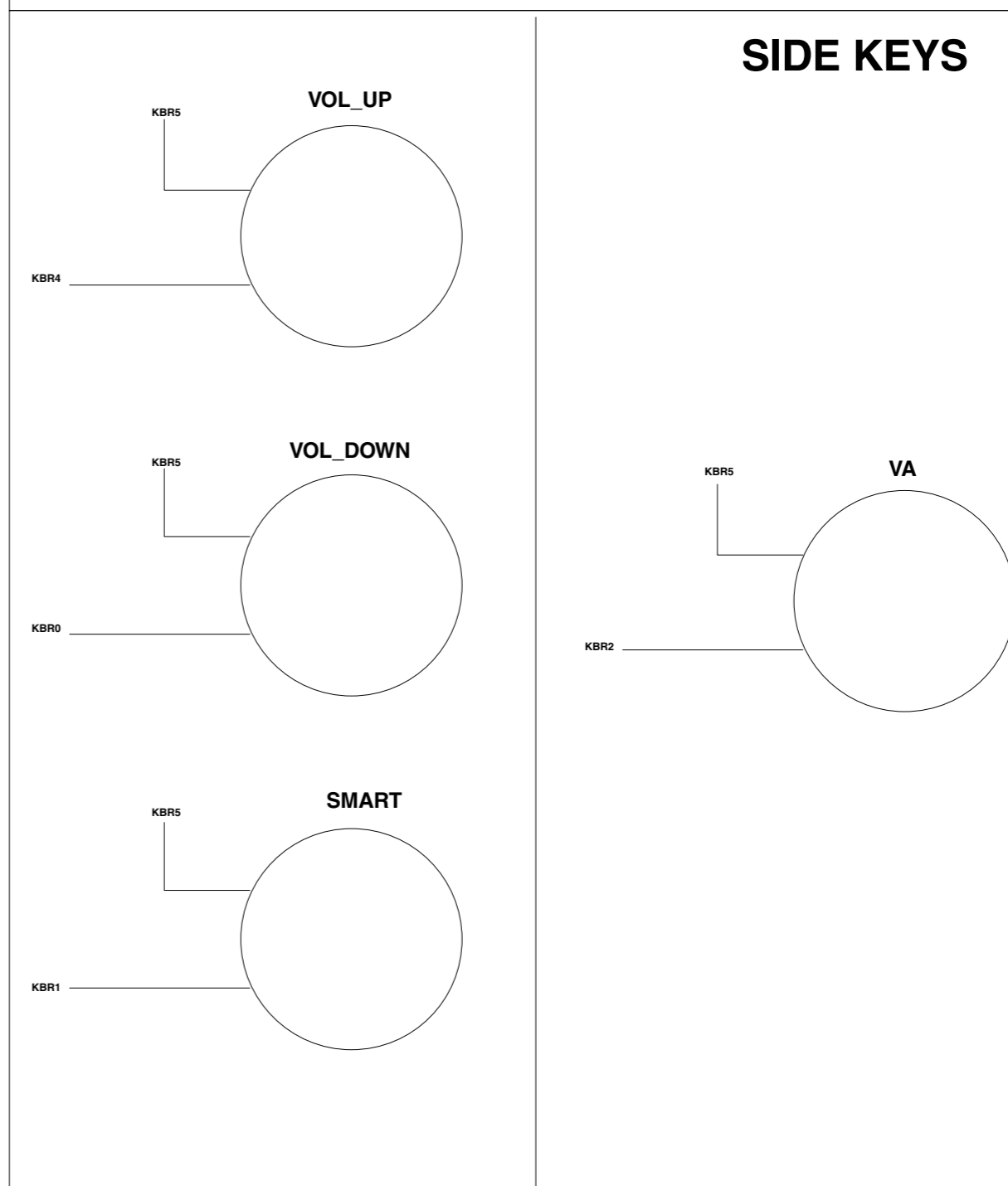
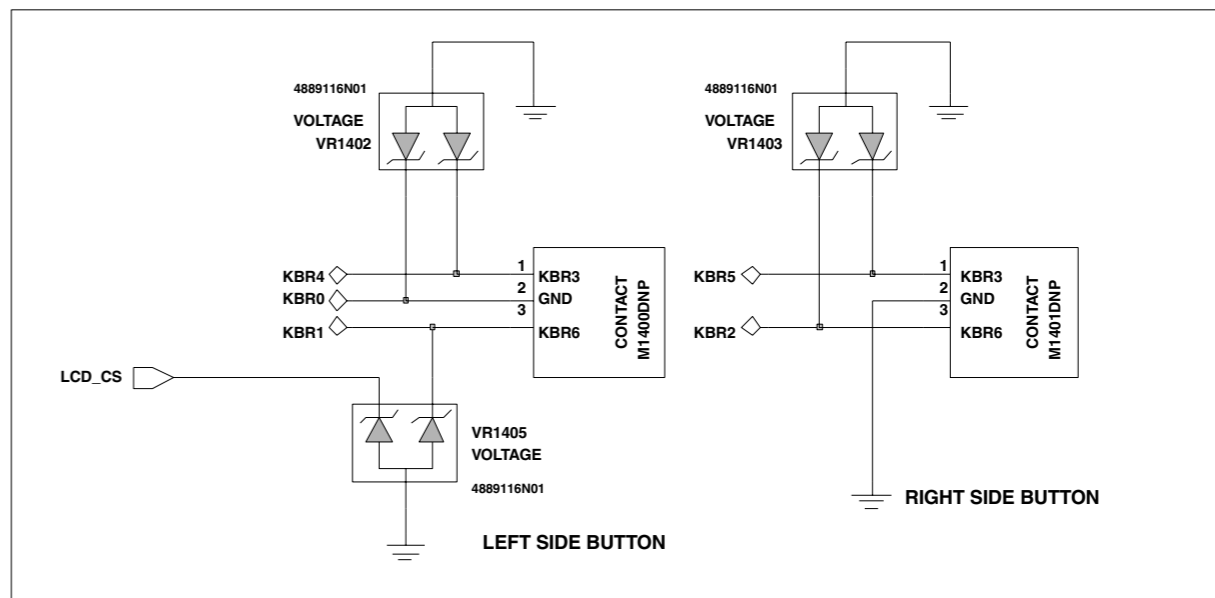
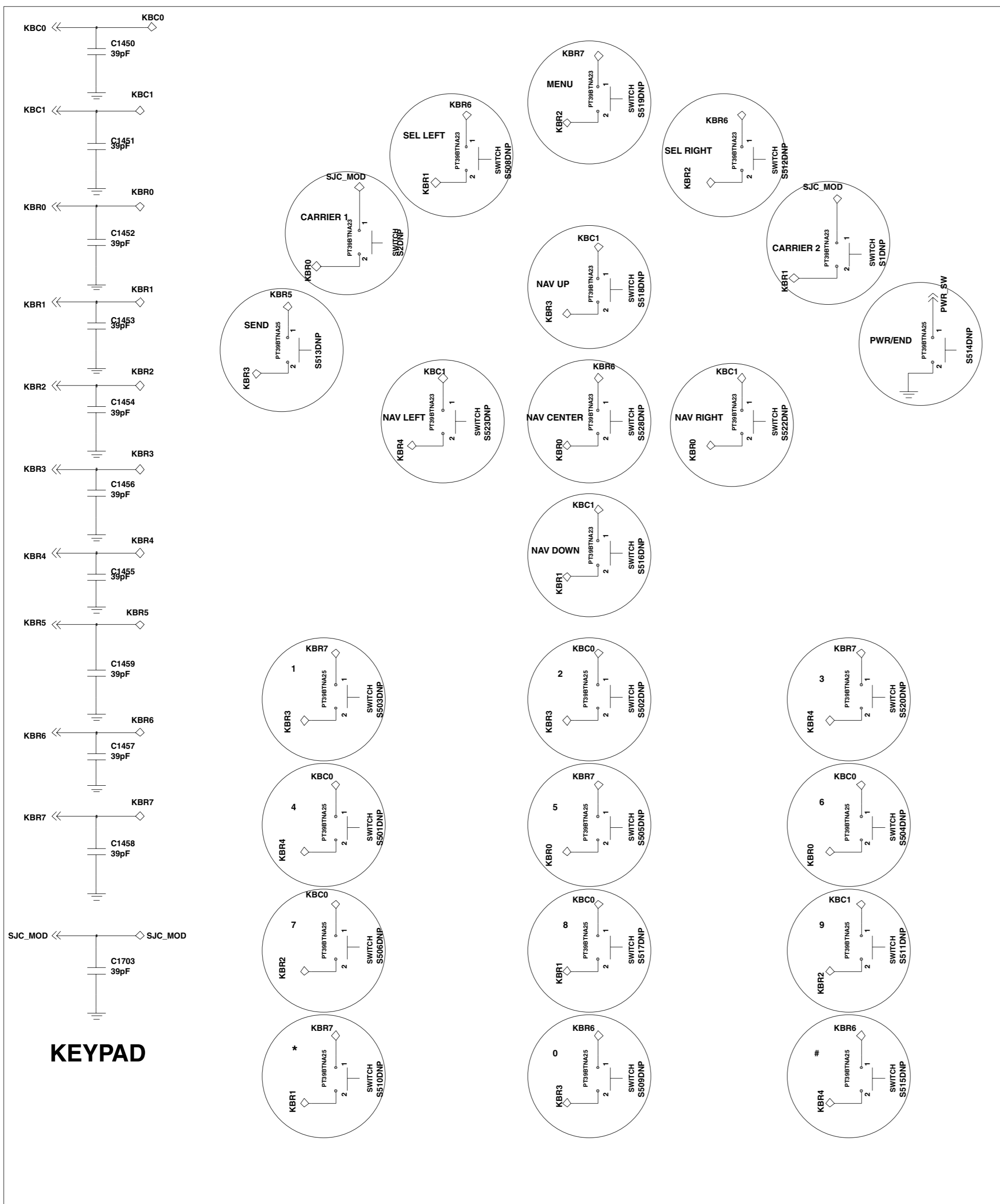

V635

Service Engineering & Optimization
Level 3 Authorized

GSM SERVICE SUPPORT GROUP	2004.11.26
Level 3 Schematics	Rev. 1.0
V635	8488789Y01_P3C
Alexander Buehler, Michael Hansen	Page 3 of 5

