

GSM Service Support
Level 3 Authorized

V600 8488258N03_D1

REVISIONS

GSM SERVICE SUPPORT GROUP	2004.02.04
Level 3 Schematics	Rev. 1.0
V600	8488258N03_D1
Michael Hansen, Alexander Bühler	Page 1 of 7

MOTOROLA INTERNAL USE ONLY

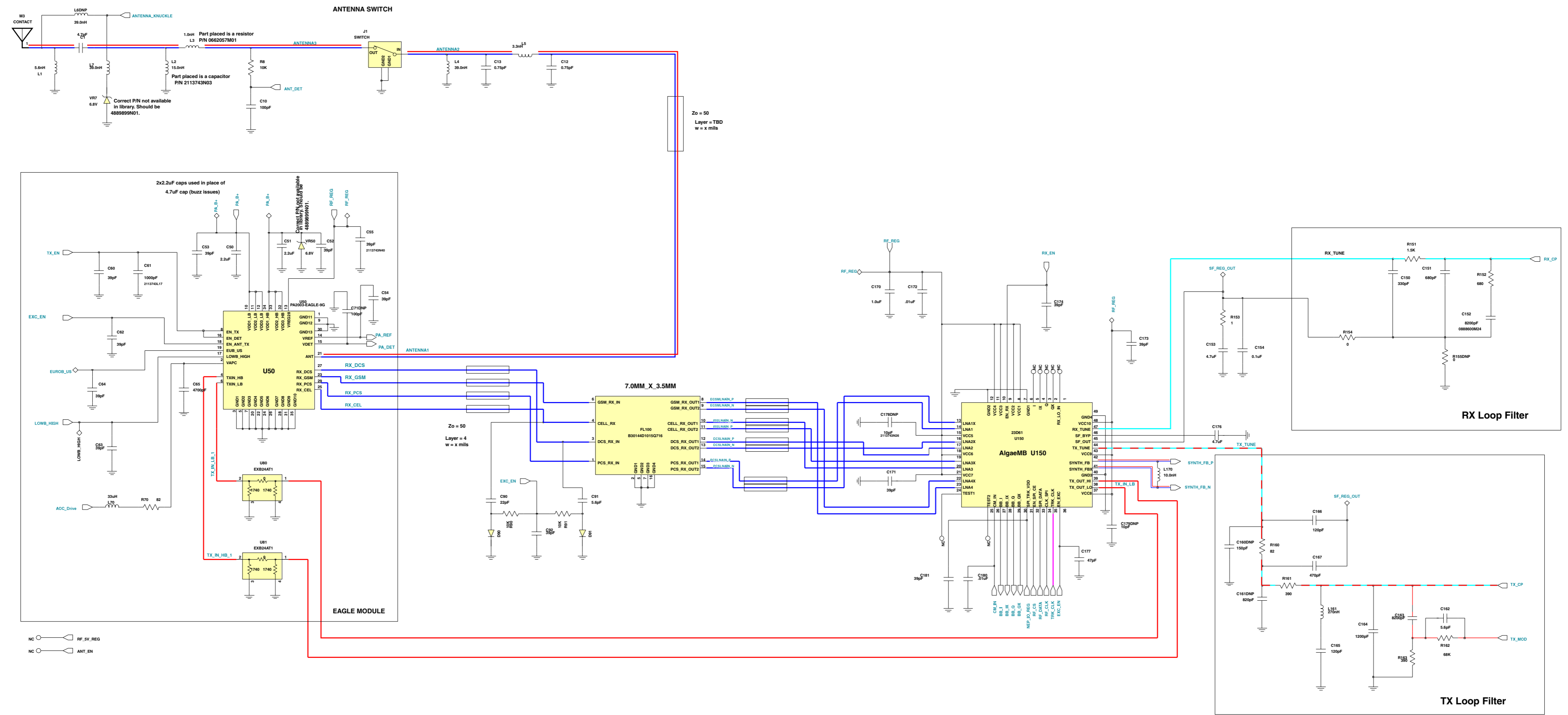

GSM
Service Support
Level 3 Authorized

V600 8488258N03_D1

GSM SERVICE SUPPORT GROUP	2004.02.04
Level 3 Schematics	Rev. 1.0
V600	8488258N03_D1
Michael Hansen, Alexander Bühler	Page 2 of 7

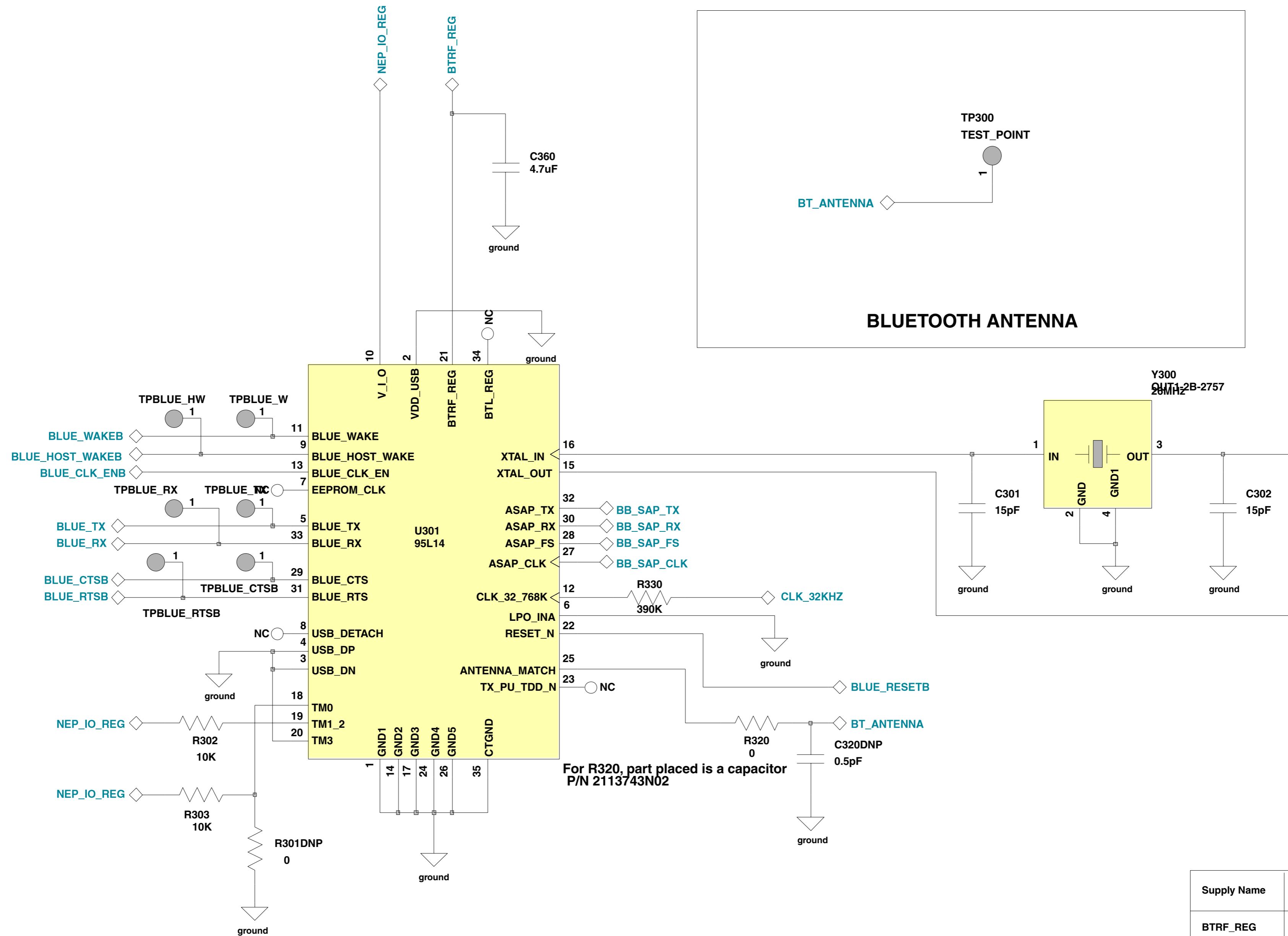

For R320, part placed is a capacitor
P/N 2113743N02

Supply Name	VDC
BTRF_REG	1.8
NEP_IO_REG	2.75

GSM
Service Support
Level 3 Authorized

V600 8488258N03_D1

GSM SERVICE SUPPORT GROUP	2004.02.04
Level 3 Schematics	Rev. 1.0
V600	8488258N03_D1
Michael Hansen, Alexander Bühler	Page 3 of 7

Remove the MOD Test point
and resistor R805 on the
final production board.
Need to add Jumper to Wing board.

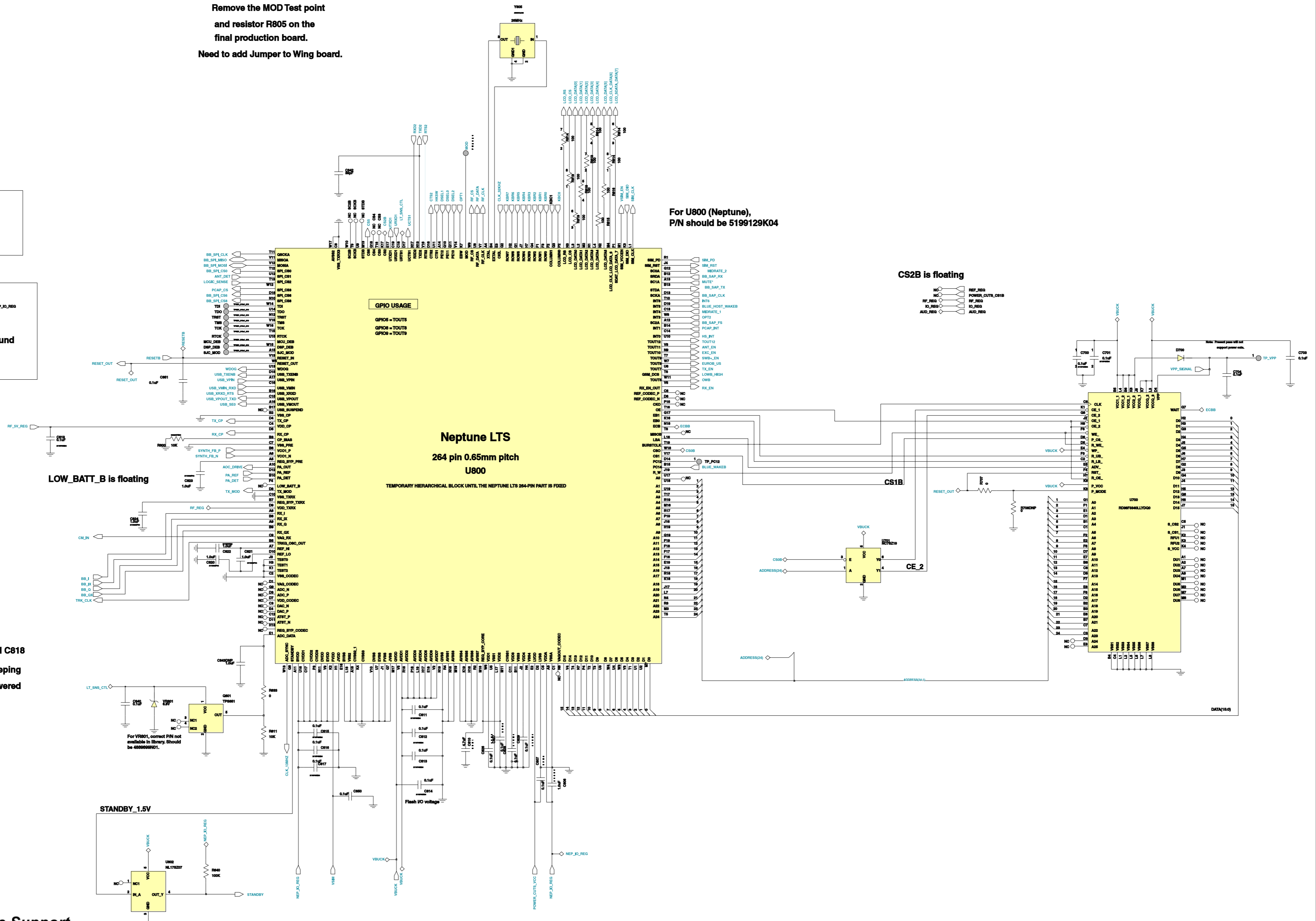
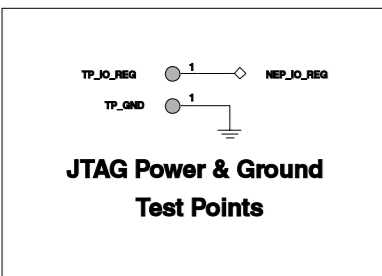
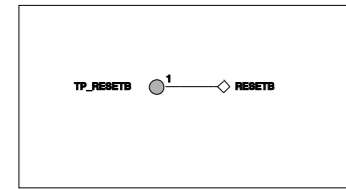

Only place R810, R811 and C818
if there is an issue in keeping
the CODEC and ADC unpowered
Route JVDD carefully

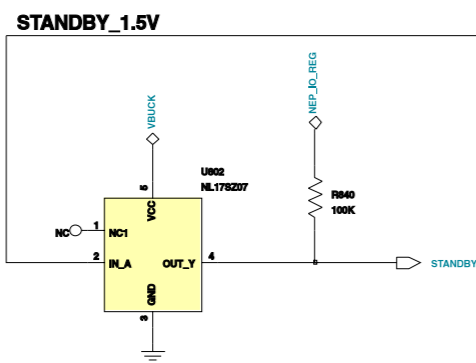

GSM
Service Support
Level 3 Authorized

V600 8488258N03_D1

GSM SERVICE SUPPORT GROUP	2004.02.04
Level 3 Schematics	Rev. 1.0
V600	8488258N03_D1
Michael Hansen, Alexander Bühler	Page 4 of 7

MOTOROLA CONFIDENTIAL PROPRIETARY

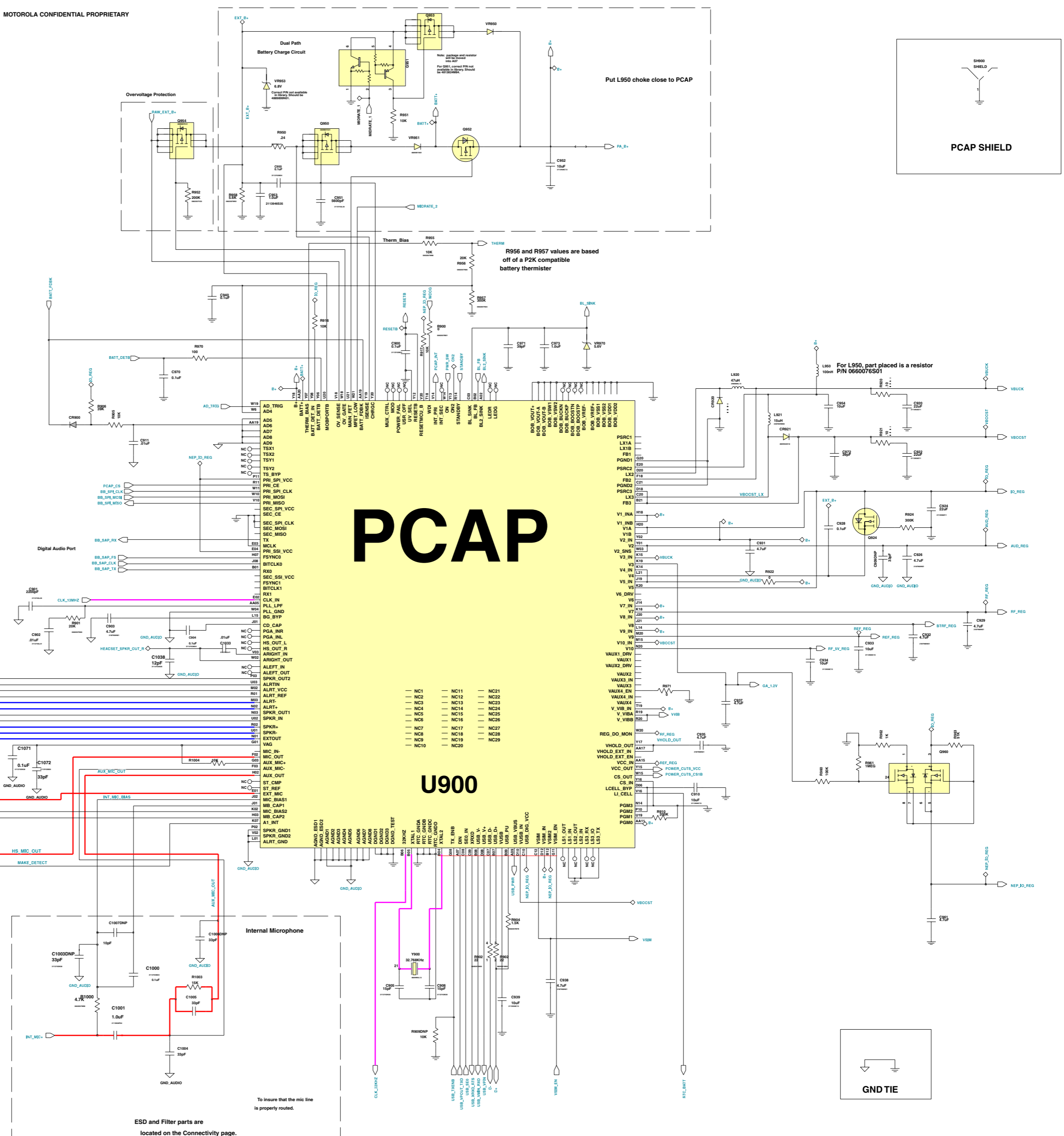
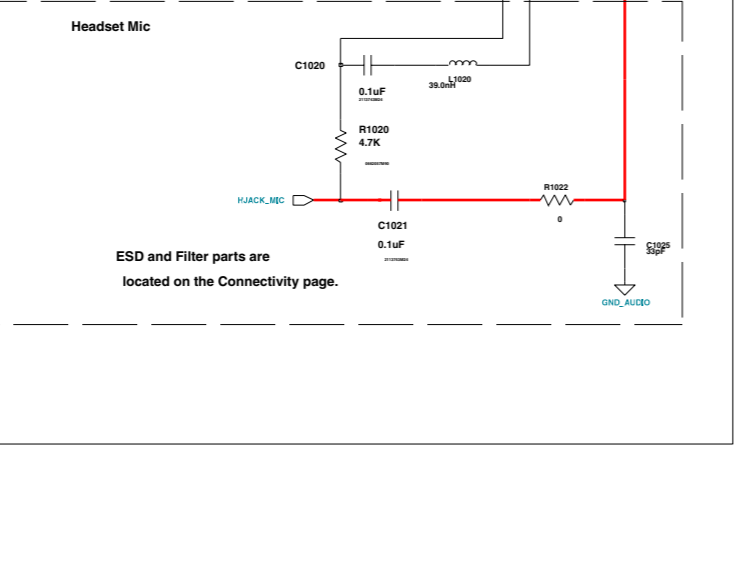
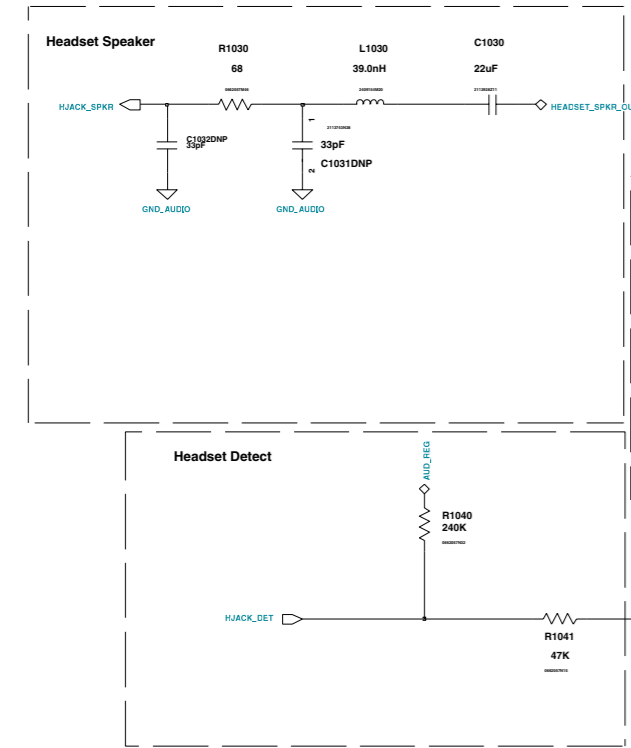
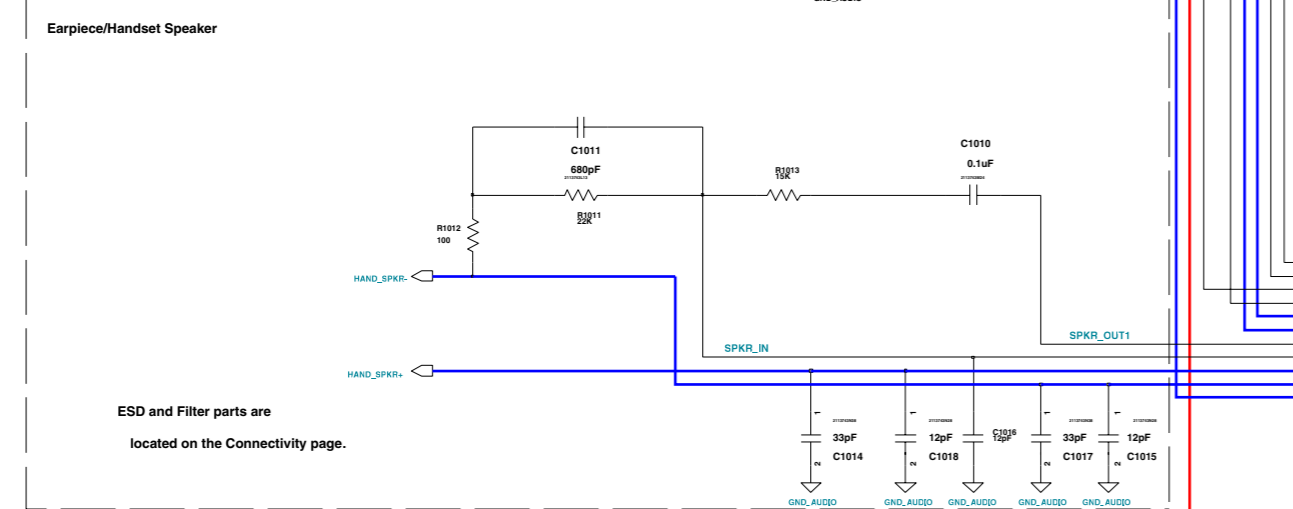
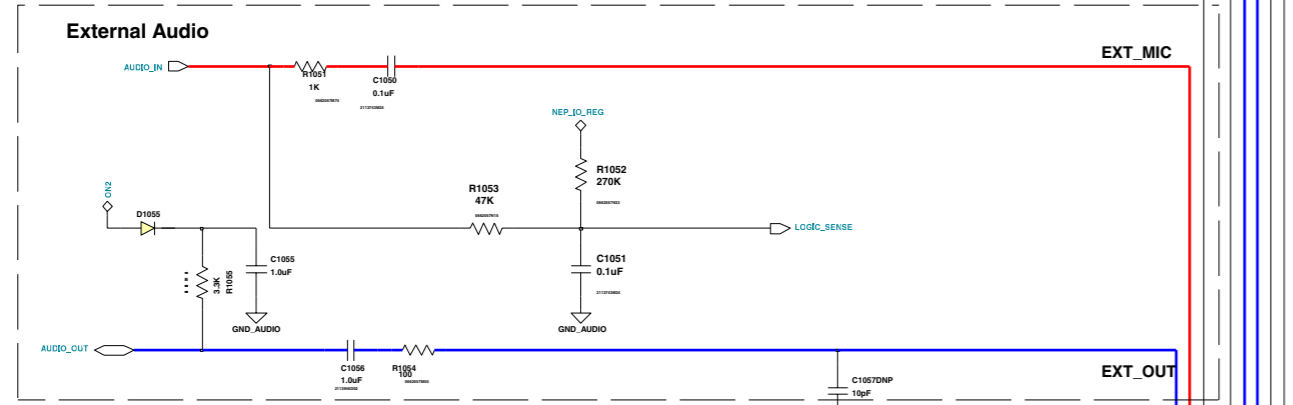
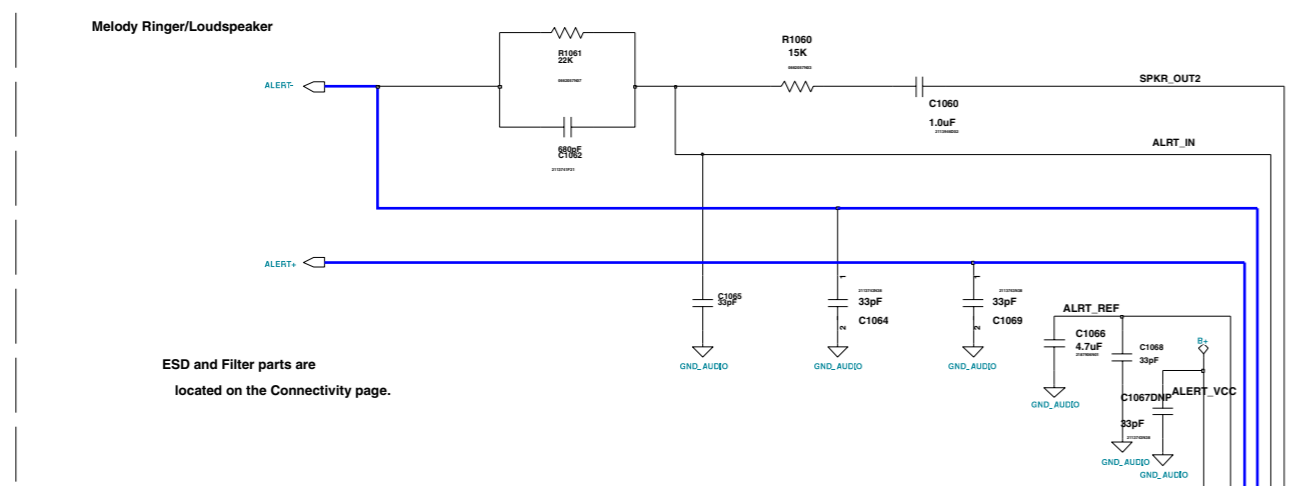

PCAP

U900

GSM Service Support Level 3 Authorized

V600 8488258N03_D1

GSM SERVICE SUPPORT GROUP	2004.02.04
Level 3 Schematics	Rev. 1.0
V600	8488258N03_D1
Michael Hansen, Alexander Bühler	Page 5 of 7

MOTOROLA INTERNAL USE ONLY

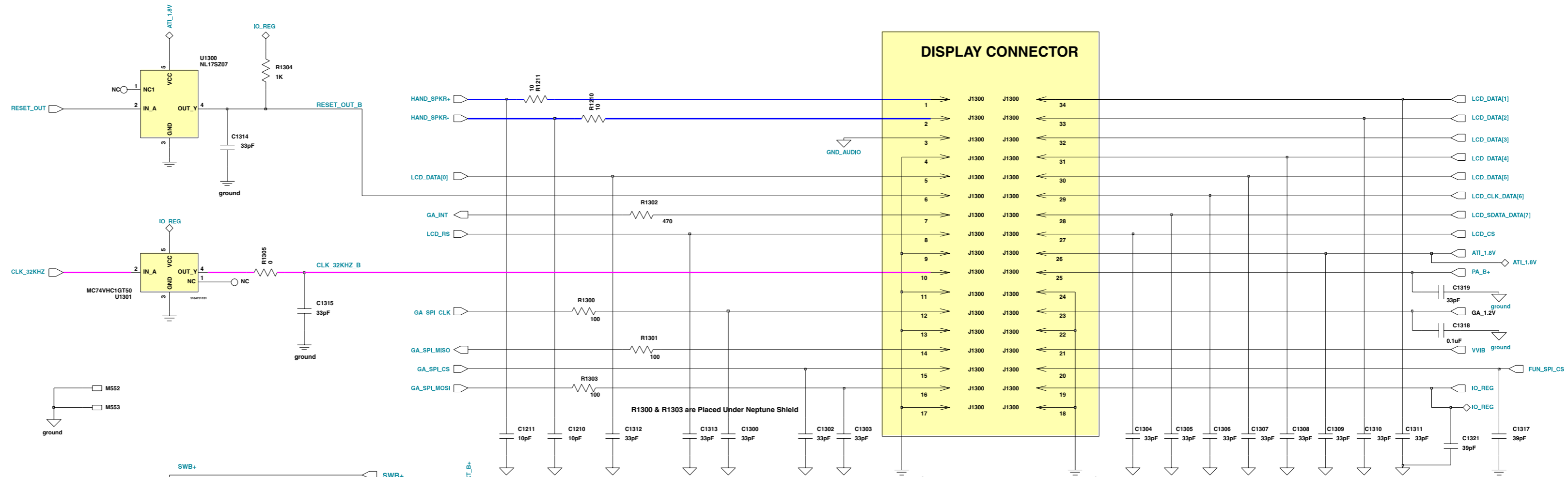
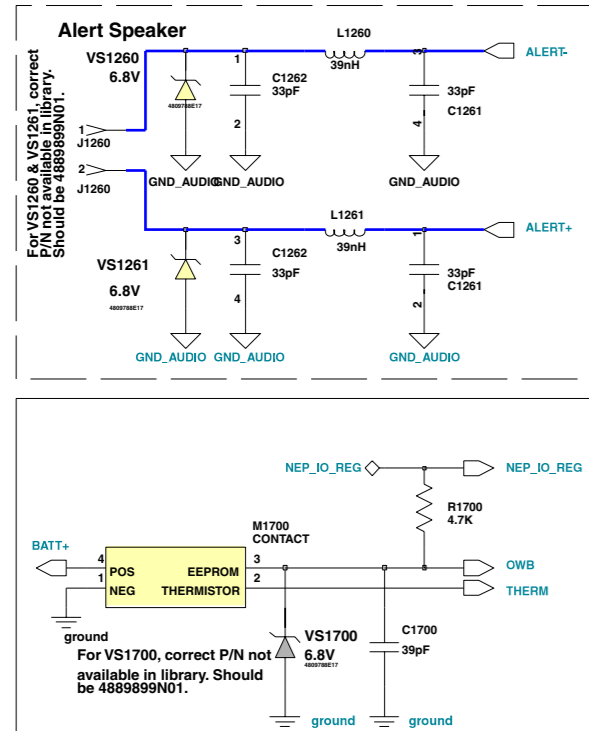

**Accessory Connector
CE Connector (0987636K06)**

- 1 BATT_FDBK
 - 2 EXT_B+
 - 3 D+ / TXD / TDO
 - 4 D- / RXD / TDI
 - 5 USB_PWR / IGN / SEND_END / RTS / RESET_IN
 - 6 SWB+
 - 7 HKSW / FM_DATA / CTS / DE_B
 - 8 MUTE* / FS / DCD
 - 9 DSEL2 / SCK / RI / TCK
 - 10 DSEL1 / FM_CLOCK / SRDA / DTR / TMS
 - 11 DSEL0 / FM_EN / STDA / DSR / TRST_B
 - 12 OPTION1
 - 13 OPTION2
 - 14 AUDIO_OUT / 12V Flash / 8V JTAG
 - 15 AUDIO_IN
- B0 - Normally Closed**
B1 - Normally Open
S - Select
A - Common

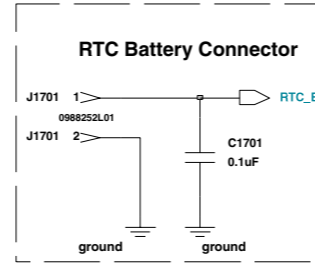
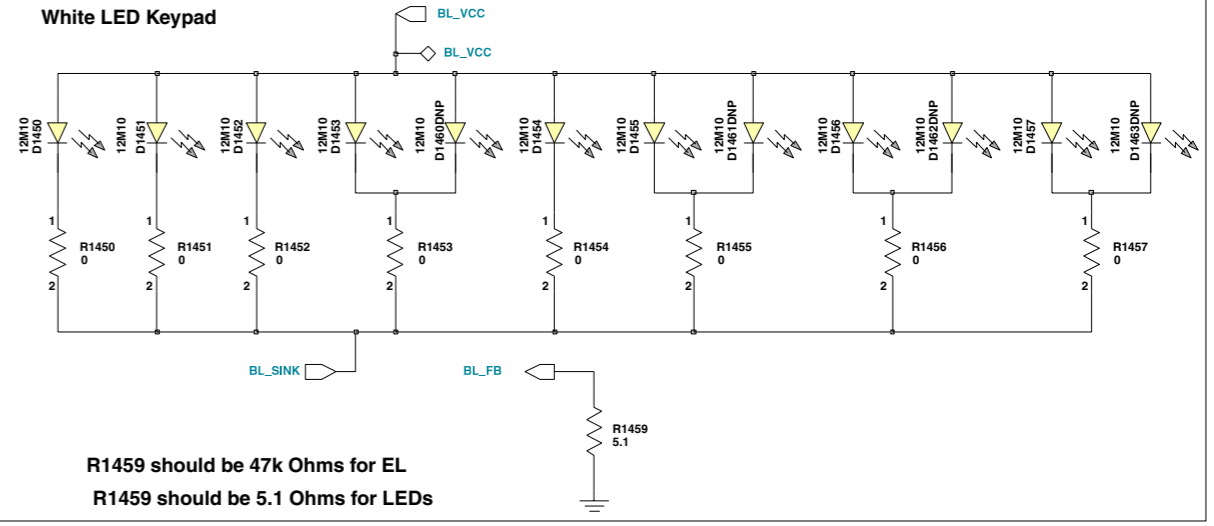
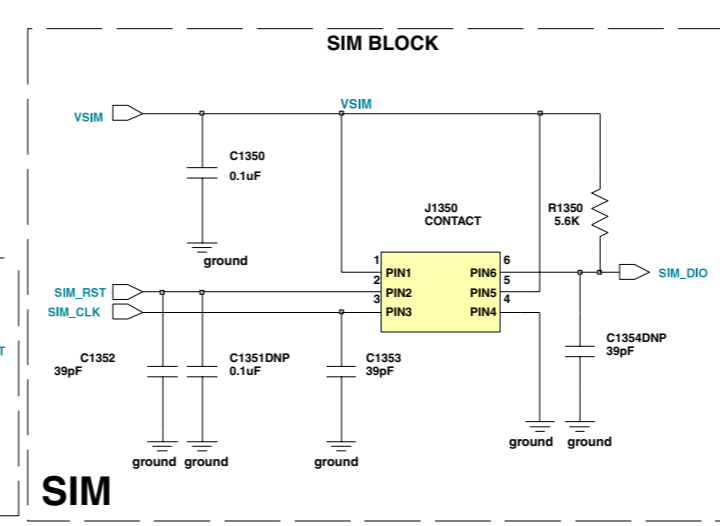
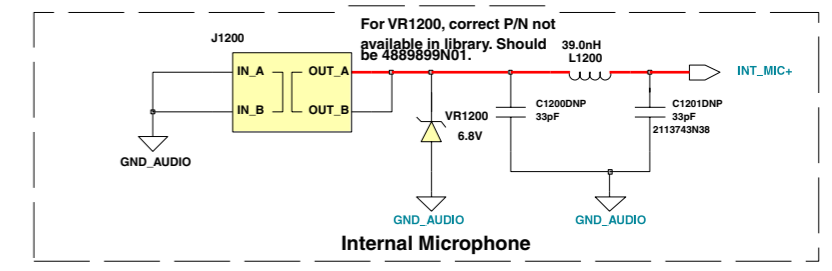
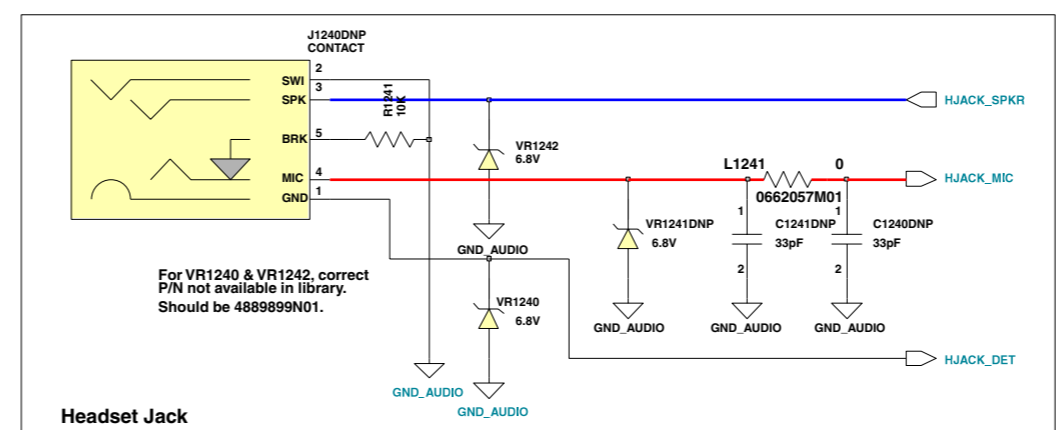
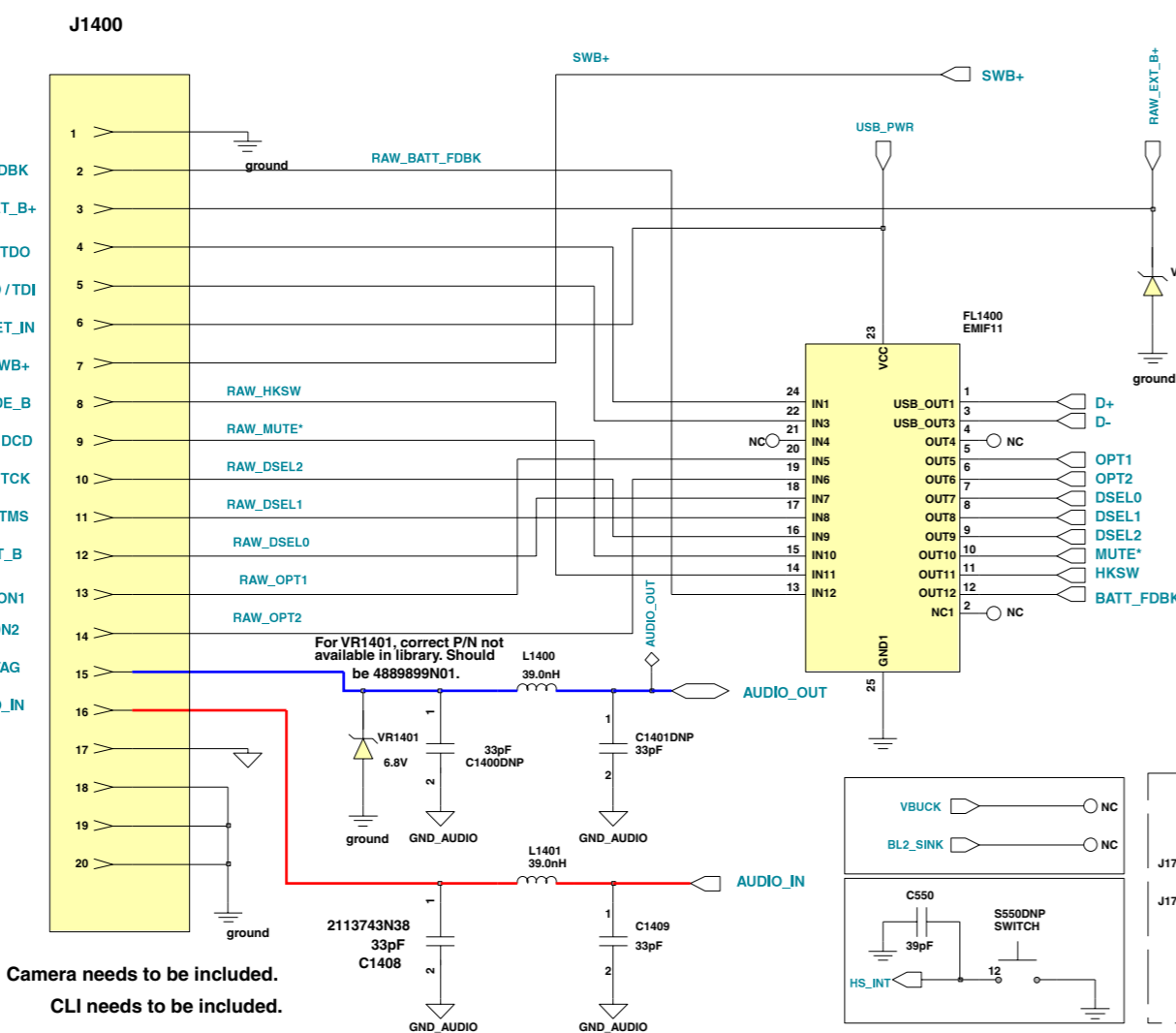

GSM Service Support
Level 3 Authorized

V600 8488258N03_D1

GSM SERVICE SUPPORT GROUP	2004.02.04
Level 3 Schematics	Rev. 1.0
V600	8488258N03_D1
Michael Hansen, Alexander Bühler	Page 6 of 7

