



MOTOROLA

Service Manual Level 3



Motorola V120e

CDMA 800/1900/AMPS 800

COMPUTER SOFTWARE COPYRIGHTS

The Motorola products described in this instruction manual may include copyrighted Motorola computer programs stored in semi-conductor memories or other media. Laws in the United States and other countries preserve for Motorola certain exclusive rights for copyrighted computer programs, including the exclusive right to copy or reproduce in any form the copyrighted computer program. Accordingly, any copyrighted Motorola computer programs contained in the Motorola products described in this instruction manual may not be copied or reproduced in any manner without the express written permission of Motorola. Furthermore, the purchase of Motorola products shall not be deemed to grant either directly or by implication, estoppel, or otherwise, any license under the copyrights, patents or patent applications of Motorola, except for the normal non-exclusive, royalty free license to use that arises by operation of law in the sale of a product.

Set Up for CDMA Call	40	TX A08B	87
Making a CDMA Phone Call	41	TX1900 A08C	88
Set Up for CDMA RF Parametric Measurements	42	TX800 A08D	89
Making a Receiver Sensitivity Measurement 43		Connectors A9	90
Receiver Test Termination	44	Harness/PWR(PM) A10	91
CDMA Transmitter Tests	45	PWR (PM) A10B	92
CDMA Transmitter Power Range Test .46		Memory/Proc A11	93
FER with AWGN Tests	47	MSM A11b	94
V120E -AGPS Testing Procedure.48		MSM Circuit A11	95
		Keypad A12	96
		Side 1 A13	97
		Side 2 A13	98
Radio Comm.	50		
T120e Test Procedure	51	Replacement Parts	99
800 CDMA RX Test Set UP	55	Mechanical Parts List	100
800 CDMA TX Test Set UP	59	Electrical Parts List	101
Troubleshooting.	60		
No Turn ON -Debug Procedure	61		
Internal Charger Test Debugging.	61		
Receiver Troubleshooting	62		
Antenna Circuit A3	66		
Antenna Circuit A3B	67		
Duplexer Circuit A3c	68		
AGPS Antenna A03D	69		
FE Circuit A4B	70		
FE/IF CDMA A04	71		
IF Circuit A04C	72		
IF Cell/REF OSC A5	73		
IF Circuit A05B	74		
IFFILT Circuit A05C	75		
Circuit A05D	76		
REF OSC Circuit A05E	77		
IFFILT CDMA Circuit A05F	78		
IFFILT GPS Circuit A05G	79		
PWR DET/TXUPMIX A06	80		
PWR DET/TXUPMIX A06B	81		
PWR DET/TXUPMIX A06C	82		
SYN A07B	83		
SYN A07B	84		
SYN A07	85		
PA'S A08	86		

CDMA DUAL BAND TRI MODE PHONE

General:

120e CDMA Dual Band Tri Mode Phone

120e is a CDMA2000 1XRTT version of V.120C. It uses Qualcomm chip set and software. This is a dual band tri mode phone- 1900Mhz CDMA / 800Mhz CDMA / 800Mhz AMPS.

What is 1X?

CDMA 1X has many names such as CDMA 2000, IS-2000, 2.5G, CDMA One, IS95C, and 3G1X. As a fundamental way of thinking CDMA 1X is to CDMA as NAMPS is to AMPS. Using the 1.25 MHz bandwidth of a CDMA channel the CDMA 1X can adjust the amount of supplemental channels based on the data needs.

Advantages of CDMA 1X:

1. Approximately 2X voice capacity over IS-95B.
2. High Data Rates:
 - 144 kbps full mobility
 - 384 kbps low speed mobility
 - 2 Mbps for fixed installations
3. Easy up grade for service providers who are currently operating systems using IS-95. All software enhancements.
4. Backward compatible with IS-95
 - 120X due to lower cost chipset can support data rates of 153.6kbps down/9.6kbps up.
5. 120X is similar to V.120C in looks, form factor, housing and accessories. There are a number of key enhancements added to the design.

- Silver color for front housing and battery door
- TMF display(vs current super twisted nematic display)
- Lens color changed to match the silver housing.
- Chrome finish to the lens bezel.



KEY PRODUCT FEATURES

- Higher data rates
- Stylish and sleek design that fits perfectly in your hand for optimal comfort
- Save time with voice activated dialing and menu control
- Make notes using the 120 seconds voice note recorder
- Fast and easy text messaging including E-Mail making it easy to stay in the loop
- Create an entertainment experience with optimal FM stereo Radio and MP3 player accessories.
- WAP micro browser for instant access to valuable information while on the go
- Full PIM functionality with alarm and calendar settings
- Up to 500 names and number entries in address book with unlimited entries per name
- Add distinctive alert to selected address book entries and recognize incoming ID by alert
- Three Games
- Personalize your own look with colorful Phone Wrap cover
- 19 keys on the keypad for synergy support
- Volume and smart keys on the sides
- Integrated headset jack on the top above which is the power button

Accessory connector:

- 17 pins CE bus connector, access to USB, RS232, power, ground, analog and digital audio, FM stereo headset.
- Batteries: 1000 mAh Lithium ion same as V.120C

120X AUDIO LOGIC ICs

Brief IC functional description:

1. Qualcomm Baseband IC is used in 120e
 - U1000: MSM5105 –uP, DSP, CoDec, Vocoder, ADC, PDM, RF interface, USB logic.
 - U3000: PM1000-LDO's, RTC/XO, GP ADC, State Machine w/POR, Battery Control, SBI Control.
 - U200: IFR3000: RX IF- Baseband Converter extracts BB components from CDMA/Amp signals.
 - U130: RFR3300: LNA, mixer
 - U500: RFT: Baseband to RF transmit processor.
 - PA2001: 4C/5C
2. Non Qualcomm Baseband IC is used in 120X
 - U2000: 32 Mbit (4 Mbyte) Intel Sawtooth C3-Main software code
 - U2001: 8 Mbit (1Mbyte) Intel Jaguar B3-NVM for phasing, voice notes, phone book, etc.
 - U2002: 8 Mbit(1 Mbyte) SRAM
 - U3800: Semtech SC801 Charger Controller
 - U5000: Harness ASIC - Have the following features: 1. Parallel to Serial conversion 2. 16 additional dedicated GPIO and 8 optional GPIO 3. EPIT (Enhanced Programmable Interrupt Timer) 4. CE bus multiplexing, to allow Qualcomm based radio to look like a CE bus compliant radio. 5. One wire bus serial interface for battery EPROM.
 - U5001: Phillips ISP1105 USB transceiver
 - Y3000: 32.768Khz xtal- provide reference clock to the microprocessor during sleep mode operation.

CDMA-PCS 1900 Mhz BAND

Performance specification:

General Frequency and channel information:

Channel No., Tx Frequency (Mhz), Rx Frequency (Mhz)

<i>Channel No.</i>	<i>Tx Frequency (Mhz)</i>	<i>Rx Frequency (Mhz)</i>
25	1851.25	1931.25
200	1860.00	1940.00
400	1870.00	1950.00
600	1880.00	1960.00
800	1890.00	1970.00
1000	1900.00	1980.00
1175	1908.50	1988.50

The 1900 MHz band is split into 6 blocks(ABCDEF) of channels. usually only one block is used in a given geographic area.

There are no “standard” primary and secondary channels.

The actual primary and secondary channel depends on which block is used.

The lowest valid channel number is 25.

The highest valid number is 1175.

Total Number of valid channel numbers is 46.

CDMA 1900MHz Performance Specifications
General.

1

Table 1: Specifications

<i>Function</i>	<i>Specification</i>
Frequency Range	1850 to 1910 MHz(tx), 1930 to 1990(RX)
RF Channel Bandwidth	1.25 MHz
Channels	46 (Channel number spaced at an increment of-25, beginning channel, #25 lowest frequency and ending channel number 1175 highest frequency)
Duplex Spacing	80 MHz
Frequency Stability	Center Frequency* +/- 8.5×10^{-8} +/- 150 Hz of incoming RX CDMA signal.
Operation Voltage	+3.6 V nominal (3.0 -4.4 V DC)
RF Power output	0.20 Watts - 23 dBm into 50 ohms (CDMA, nominal)
input/output impedance	50 ohms(nominal)
Spurious /Harmonic emissions	Complies with title 47, Part 22 of the code of federal regulations.
Vocoders	8kbps, 13kbps, EVRC
Transmit Time Error	+/- 1 US
Modulation Type	1M25D1W(1.25MHz bandwidth), OQPSK, G7W(CDMA)
Transmit Duty Cycle	Variable- full, 1/2, 1/4, 1/8 rate(CDMA Mode)
CDMA Transmit Waveform Quality(rho)	0.94
Receive Sensitivity	-104dBm(CDMA, 0.5% Static FER, 8kbps Vocoder)
Display	Large 96X64 Graphic LCD Display offering 4 Lines of Text,! Line of icons and I line of Prompts.

Specifications

CDMA 800 MHz Channel Numbering

General information:

The 800 MHz CDMA channel numbering evolved from the Amps analog system which shares the same spectrum.

The Amps channel spacing is 30 KHz, because the CDMA signal BW=1.25 MHz, the actual CDMA signal must be spaced every 41 channels

$$(41 * 30 \text{ KHZ} = 1.23 \text{ MHz})$$

In a dual-mode system, CDMA signals would never occupy analog control channels 313 to 354.

A -System preferred channels: primary =283,
Secondary = 691

B- System preferred channels: Primary =384,
Secondary = 777

The lowest valid CDMA channel is 1013.

The highest valid CDMA channel is 777.

Table 2: Overall System CDMA 800MHz

Function	Specification
Frequency Range	824.04 - 848.97 MHz Tx, Channels 1 to 799, $f_{Tx} = 0.03 * N + 825$ MHz Channels 990 to 1023, $f_{Tx} = 0.03(N-1023) + 825$ MHz 869.04 - 893.97 MHz Rx Channels 1 to 799 is $f_{Rx} = 0.03 * N + 870$ MHz Channels 990 to 1023, $f_{Rx} = 0.03(N-1023) + 870$ MHz
Channel Spacing	30 KHz
Channels	832
Duplex spacing	45 MHz(amps)
Frequency Stability	+/- 2.5 ppm (Amps)
Operating Voltage	+3.6 v nominal (3.0v to 4.4 v DC)
Display	96 X 64 Pixel array 120X have a one line external display to allow viewing of caller ID and other phone status messages while the flip is closed.
RF Power Output	max power 25dBm for CDMA(800 & 1900) and 26.1 dBm for Analog.
Input/Output Impedance	50 ohms (nominal)
Spurious / Harmonic Emissions	Complies with Title 47, Part 22 of the code of Federal Regulations.
Audio Distortion	Less than 5% at -26dB
Hum and Noise(C-MSG)	32 dBm below +/- 8kHz deviation(transmit and receive)
Modulation	F3: + 12 kHz for 100% at 1 kHz, AMPS (wide) 1M25D1W (1.25 MHz bandwidth) CDMA
Transmit Audio Response	6 dBm/octave pre-emphasis
Transmit Audio sensitivity	(AMPS) + 2.9 kHz deviation (nom.) @ 97 dBm SPL input @ 1 kHz
Transmit Duty Cycle	full, 1/2, 1/4, 1/8 rate (CDMA Mode)
CDMA Transmit Waveform Quality(Rho)	0.94
Receiver Sensitivity	-116 dBm (AMPS, SINAD, C-MSG weighted) Sinad 12dB or greater -104 dBm (CDMA, 0.5% Static FER) 0.5% or less
Alternate Channel Desense Protection	-60 db@ +/- 60kHz (Amps)

Table 3: Environmental

<i>Function</i>	<i>Specification</i>
Temperature Range	Operational -30 °C to +60 °C (-22 °F to +140 °F) Storage -55 °C to +85 °C (-67 °F to +185 °F) Thermal Shock -40 °C to +85 °C (-40 °F to +185 °F) meets Mil. Std. 810C
Shock	Exceeds EIA Standards RS152B (Section 15) and IS-19
Drop	Exceeds EIA Standards RS316B and IS-19
Humidity	95% Relative Humidity; meets EIA Standard IS-19
Vibration	Exceeds EIA Standards RS316B and IS-19
Salt Fog	Salt Solution fog at 35 °C (95 °F), tested for 48 hours
Dust	140 mesh blown silica flour test, tested for 5 hours
Notes:	<ul style="list-style-type: none"> • EIA (Electronic Industries Association) Standard RS152B states the minimum standards for Land Mobile Communications, FM or PM transmitters 25-470 MHz. • EIA IS-19 states the recommended standards for 800 MHz cellular subscriber units. • EIA Standard RS316B states the standards for portable land mobile communications. • U.S. Military Standard 810D establishes uniform environmental test methods for determining the resistance of equipment to the effects of natural and induced environments peculiar to military operations. • TIA/EIA/IS-98 Recommended Minimum Performance Standards for Dual-Mode Wide band Spread spectrum Cellular Mobile Stations.

Specifications subject to change without notice.

Foreword

Scope of Manual

This manual is intended for use by experienced technicians familiar with similar types of equipment. It is intended primarily to support basic servicing, which consists primarily of mechanical repairs and circuit board replacement.

Authorized distributors may opt to receive additional training to become authorized to perform limited component repairs. Contact your regional Customer Support Manager for details.

Replacement Parts Ordering

Motorola maintains a parts office staffed to process parts orders, identify part numbers, and otherwise assist in the maintenance and repair of Motorola Cellular products. Orders for all parts should be sent to the Motorola International Logistics Department at the following address:

Accessories and After market Division Motorola Personal Communications Sector

Schaumburg, IL 60196

International Motorolans that need to purchase parts should contact AAD via one of the following numbers:

Phone: 1-847-538-8023, Fax: 1-847-576-3023

However, domestic Motorolans should contact AAD via one of the following numbers:

Phone: 1-800-422-4210, Fax: 1-800-622-6210

<http://accesssecure.mot.com/Accesspoint/cgi-bin2/SoftCart.exe/Accesspoint/quick.html?L+test+rkod3498+930004870>

When ordering replacement parts or equipment information, the complete identification number should be included. This applies to all components, kits, and chassis. If the component part number is not known, the order should include the number of the chassis or kit of which it is a part, and sufficient description of the desired component to identify it.

Model and Kit Identification

Motorola products are specifically identified by an overall model number on the product label. In most cases, assemblies and kits which make up the equipment also have kit numbers stamped on them.

Service

Motorola's regional Cellular Subscriber Service Centers offer some of the finest repair capabilities available to Motorola Subscriber equipment users. The Cellular Subscriber Service Centers are able to perform computerized adjustments and repair most defective transceivers and boards. Contact your regional Customer Service Manager for more information about Motorola's repair capabilities and policy for in-warranty and out-of-warranty repairs in your region.

General Safety Information

CAUTION

Do not jump start vehicle or use an automotive battery charger while the vehicle adapter option and the portable radiotelephone are connected to the vehicle electrical system, as this may cause serious damage to the radio. Disconnect the radio by removing the cable kit fuses.

Portable Operation

DO NOT hold the radio so that the antenna is very close to, or touching, exposed parts of the body, especially the face or eyes, while transmitting. The radio will perform best if it is held in the same manner as you would hold a telephone handset, with the antenna angled up and over your shoulder. Speak directly into the mouthpiece.

DO NOT operate the telephone in an airplane.

DO NOT allow children to play with any radio equipment containing a transmitter.

Mobile Operation (Vehicle Adaptor)

As with other mobile radio transmitting equipment, users are advised that for satisfactory operation of the equipment and for the safety of personnel, it is recommended that no part of the human body shall be allowed to come within 20 centimeters of the antenna during operation of the equipment.

DO NOT operate this equipment near electrical blasting caps or in an explosive atmosphere. Mobile telephones are under certain conditions capable of interfering with blasting operations. When in the vicinity of construction work, look for and observe signs cautioning against mobile radio transmission. If transmission is prohibited, the cellular telephone **must be turned off** to prevent any transmission. *In standby mode, the mobile telephone will automatically transmit to acknowledge a call if it is not turned off.*

All equipment must be properly grounded according to installation instructions for safe operation.

Hypothetical Cell System

Operation

In Figure 1: "Hypothetical Cell System", the area bounded by bold lines represents the total coverage area of a cellular system. This area is divided into several cells, each containing a cell site base station which interfaces radiotelephone subscribers to the switching system. Since there are no reserved channels for each cell in CDMA, a user has a better chance of completing a call. Also, now there is no hard handoff between cell sites since all sites operate on the same frequency. This is called soft handoffs. In this system, subscribers in cell A & D simultaneously operate in the same frequency. As a user moves from cell site to cell site, the base station monitors the signal strength of the user. Based on this signal strength, the base station decides which cell shall carry the call.

When a radiotelephone is in use well within a cell, the signal strength received at the cell site base station will be high. As the phone is moved towards the edge of the cell, its received signal strength decreases. Signal strength information therefore provides an indication of the subscriber's distance from a cell's base station. This change is handled automatically, and is completely transparent to the user. For example, assume that a cellular telephone initiates a call in cell A and then moves across the system area through cells B and C to cell D. As the phone moves into cell B, it is instructed to change to a different frequency that operates through the B cell on that frequency. A similar change is performed when the phone moves from cell B to cell C and again when the phone moves from cell C to cell D.

In this example, the radiotelephone has operated in four cell sites, through four cell sites, and on the same spread spectrum without interruptions in voice communications. As the radiotelephone leaves a cell, the frequency on which the phone and base station were operating is made available to another subscriber in that cell. Since this radiotelephone is dual mode, the radiotelephone can operate in either a CDMA system or Analog system.

Service Area

The area within which calls can be placed and received is defined by the system operator. (Because this is a radio system, there is no exact boundary that can be drawn on a map.) If the portable is outside the radio service area, a No Svc (no service) message will appear on the phone's display, and calls cannot be placed or received. If this happens during a conversation, the call is lost. Places where the ability to place or receive calls would be lost are in totally enclosed areas, such as underground parking garages, in buildings without windows, and in elevators. This situation would be indicated either by the No Svc message illuminating, or by the sound of either a fast busy signal or a high-low siren signal when call placement is attempted.

General usage in buildings having reasonable glass area is usually quite good. However, it may be necessary to move closer to a window to ensure reliable operation.

PCS System

(Personal communication System) is identical to this cellular system except that the radio telephone service in the frequency range of 1850 MHZ to 1990 MHZ and the duplex spacing is 80 MHZ.



**120e CIRCUIT DESCRIPTION AND
THEORY OF OPERATION**

BASEBAND OR AUDIO LOGIC SECTION

The logic part consists of (1)MSM5100(vs Wally in V.120C) which has an ARM7 microprocessor, Qualcomm DSP, CODEC, VOCODER and audio amplifiers integrated. Low voltage operation: Digital Core as low as 2.3V, I/O 2.3V to 3.0V, Analog 2.5V to 2.7V.

Basic Features Includes the Following:

CDMA Module- 1XMC,IS-95A,B IS-2000, Digital FM module, ARM7TDMI microprocessor, Vocoder (13kQCELP and EVRC), integrated CODEC, QDSP2000, R-UIM controller.

RF Interface: Digital Rx I/Q, Tx D/A

Peripherals and Interfaces: General purpose I/O(GPIO), UART(2), USB(enhanced), Keypad, Ringer, M/N conter, Housekeeping A/D, Microphone amplification, Speaker drivers, Analog “hands free kit” interface, LCD support, JTAG for debugging.

Clock Support: PLL for 19.2 Mhz(tri-mode) and 19.8Mhz(J-CDMA) TCXO frequencies, separate PLL for Code clock.

Audio Features: Echo cancellation for handset, head set and “hands free kit” applications, Audio AGC, Voice Recognition (2) Qualcomm PM1000 (vs CCAP in V.120C) is a very simple power management IC with no

integrated CODEC or audio amplifiers, it has 8 LDO voltage regulators, it doesn't have internal charge controller, instead it requires external regulated voltage and current for hardware controlled charging of Lithium Ion batteries. NiMH charging not supported. It doesn't have a USB transceiver integrated, but instead uses an USB IC and requires an external 48Mhz PLL. Power on reset control circuit, vibrator, LCD backlight, keypad backlight, buzzer/ringer, and EL display drivers. Contains RTC, and 32Khz sleep oscillator.

- PM1000 doesn't have CE bus multiplexers integrated, but instead uses an ASIC called Harness.
- LDO (Low Drop Out) Regulator Operating Voltages

Table 5:

Linear Regulator	Nominal Volt
VREG_MSMC	2.86V
VREG_MSMP	2.83V
VREG_MSMA	2.65V
VREG_IF	2.90V
VREG_SYNTN	2.90V
VREG_TCXO	2.75
VREG_RF_RX	2.90V
VREG_RF_TX	2.90V

Semtech SC801 Charger Controller:

Charging algorithm is controlled by this IC, it is more of a hardware control than software control. It also provides an overvoltage input (>6.5V), reverse current, and output short circuit protection.

120e does not support no battery/dead battery operation with fast charger since current is limited to 1A by hardware.

Harness Asic: To take care of the multiplexing of CE bus lines.

Have the following features: 1. Parallel to Serial conversion 2. 16 additional dedicated GPIO and 8 optional GPIO 3. EPIT (Enhanced Programmable Interrupt Timer) CE bus multiplexing, to allow Qualcomm based radio to look like a CE bus compliant radio. One wire bus serial interface for battery EPROM.

- USB transceiver chip does the interface function of USB to CE bus
- 32 Mbit (4Mbyte -4Mx8 bits) Intel Sawtooth-Main software code
- 32 Mbit (4 Mbyte) Intel Sawtooth C3-Main software code
- 8 Mbit (1Mbyte) Intel Jaguar B3-NVM for phasing, voice notes, phone book, etc.
- 8 Mbit(1 Mbyte) SRAM

RF SECTION

The RF side consists of 3 Qualcomm RF chipset solution: RFR3300, IFR3300 and RFT3100.

- Dual band VCO/PLL module and Cellular and PCS PA's
- RFR3300 is a tri-band/quad mode
- RF to IF analog receive IC, it contains the programmable cellular LNA gain control for all three bands and four modes and the Mixer (down converter)
- RF to IF for all three bands and four modes.
- The IF frequency for all bands and mode is 183.6Mhz.
- Programmable 1xLO and ½ xLO frequency settings, Independent CDMA, AMPS FM, and GPS IF outputs.

IFR3300 is a IF to digital baseband converter. It features the following:

- Quad mode operatin:PCS-CDMA, Cellular-CDMA, AMPS FM, and GPS position location
- Quadrature down conversion from IF to analog baseband Low pass baseband I and Q filtering with mode specific performance characteristics
- 4 bit I and Q analog to digital converters with parallel outputs for CDMA and GPS
- 8 bit I and Q analog to digital converters with serial outputs for FM
- Rx slotted operation for very low power consumption in FM mode
- Clock generators for all operating modes
- VCO for generating the receivers IF to base band LO
- Operational modes compatible with MSM devices
- Three line serial bus interface for initialization and control
-

RFT3100: Baseband to RF transmit processor, it features the following:

- Full upconversion form Analog Baseband to RF TX
- Integrated I/Q Modulator, IF VCO/PLL, SSB Upconverter, VGA, and Driver amplifiers
- Designed for dual mode cellular (CDMA/AMPS), single band PCS, or dualband PCS (PCSCDMA/AMPS) applications
- Eliminates Image-reject filter between upconverter and Driver amplifier
- Includes two Cellular and two PCS Driver Amplifier outputs, eliminating external switches
- MSM3100-controlled operation via Serial Bus Interface (SBI)
- Tx Power Control through 85 dB dynamic range VGA

VCO/PLL MODULE

This is a dual band replacing dual synthesizer, loop filter, and dual band VCO.

It features the following:

- Dual band VCO + Dual PLL module
- RF VCO frequency is 2105.28 to 2173.9 Mhz, output power is about -3 to 0 dBm
- 367.2 Mhz is Rx IF VCO frequency
- 1391.82 Mhz is GPS VCO frequency
- MSM3100-controlled operation via Serial Bus Interface (SBI)

REFERENCE OSCILLATOR

Provide reference frequency for the phone, Oscillates at 19.2 Mhz

POWER AMPLIFIER (PA)

Single PA module which contains both Cellular Band and PCS Band PA

No PA biasing

THEORY OF OPERATION

RECEIVER SECTION

The receiver section occupies a frequency band of 869 Mhz to 894 Mhz in cellular band and a frequency band of 1930Mhz to 1990Mhz in PCS band. Rf signal received from the antenna is applied to diplexer and then through duplexer to RFR3300. Inside the RFR3300 the first step is it goes through LNA, where it is amplified and then applied to BPF. Finally only necessary signals are sent to the down converter – the first mixer. At this time the down converter (first mixer) mixes the RF signal with Local Oscillator signal generated by the Dual band VCO/PLL module. The IF 183.6 Mhz in frequency (same for both the Cellular and PCS band) is derived from the mixing operation is applied to the IF band pass filter and only necessary signals are selected. The IF signal now enters the IFR IC.

First it is induced to AGC Amp inside the IFR3000/IFR3300 which is adjusted to PDM (pulse density modulation) signal by received signal strength level (RSSI). This AGC amplifier is adjusted to the size matching to the input sensitivity of IFR(analog baseband). The AGC dynamic range is approximately 90 dB.

The output of AGC is down converted at 2nd mixer in order to obtain a baseband signal necessary for demodulation. For this purpose the 2nd Local oscillator, VCO of 367.2 Mhz signal is produced which is divided in frequency by half to get 183.6Mhz second LO.

The Second IF signal is divided into I and Q signals within the baseband(Zero-IF) and then filtered through low pass filter and then get A/D conversion. This is then output from

IFR IC to MSM for decoding etc.

TRANSMITTER SECTION

Digital signal is applied in 8 bit to RFT3100 IC, the MSM output I and Q signals one by one and each of these signals passes the digital LPF and is sent to the quadrature modulator. From complex signal within the baseband the quadrature modulator makes the real spectrum of double-side band having 228.6Mhz (263.6Mhz for PCS) having obtained by dividing VCO frequency 457.2Mhz (527.2 Mhz for PCS) into half as carrier(Tx IF).

MSM5105 count from the received signal strength level (Open loop power) and generates PDM signals according to TX_AGC level appropriate for the number of power control bit not inconsistent with the total sum of Eb/No defined by the base station(Close Loop Power Control) and the calculated base station power. The dynamic range is approximately 90 dB.

The Tx IF signal of 228.6Mhz (263.6Mhz for PCS) is up-converted to UHF signal. The signal converted into transmit frequency is filtered and finally amplified by the power amplifier (PA), which then pass through the isolator, duplexer and diplexer and transmitted to the antenna.

The transmitter section occupies a frequency band of 824 Mhz to 849 Mhz in cellular band and a frequency band of 1850Mhz to 1910Mhz in PCS band.

FREQUENCY SYNTHESIZER SECTION

The frequency synthesizer uses VC-TCXO-19.2Mhz as reference frequency. 19.2 Mhz is input to the frequency synthesizer as reference input of VCO/PLL MODULE IC and then divided to frequency appropriate for the channel spacing by the reference divider in the IC.

This IC generates LO signal for the conversion of Transmit/Receive carrier frequency. One is used LO signal to down convert at the 1st mixer in the receiver and the other is used as local signal for transmitter up converting mixer. Inside the IC the prescaler and the variable divider divides the input frequency(feed back) according to the channel number and frequency and then the phase detector compares it with the reference frequency and any correction is communicated through the LPF to the VCO.

The digital data for the determination of channels for the frequency synthesizer is sent from the MSM and consists of SYNTH_CLK, SYNTH_DATA, and SYNTH_LATCH in serial interface.

Table 6: FREQUENCIES

AMPS VCO	2105.28 to 2155.14 Mhz
CELLULAR CDMA VCO	2105.28 to 2155.14 Mhz
PCS CDMA VCO	2113.60 to 2173.60 Mhz
AMPS RX IF & AGPS	183.6 Mhz
CELLULAR CDMA RX IF	183.6 Mhz
PCS CDMA RX IF	183.6 Mhz

RECEIVER AUDIO

Output from IFR 3300 IC signals
C_RX_Q(DATA0,DATA1,DATA2,DATA3)
and C_RX_I(DATA2,DATA3),
FM_RX_IDATA, FM_RX_QDATA these
signals carries the baseband signal of the
receive digital call to MSM5100.

The received QPSK data is gain controlled and converted to digital, the Rx data stream is then decoded by the CSP inside the MSM to produce a signal containing only the desired data.

The digital speech is further decoded by the QCELP vocoder a part of the DSP within MSM and then converted back into analog receive audio and routed to the speaker.

TRANSMITTER AUDIO

Audio from the Microphone is routed to the MSM5100 where it is digitized by the CODEC inside MSM and the DSP within processes by QCELP variable rate vocoder and then coded by the Modem (CSP) which produces CDMA data stream.

This stream is then converted to analog signals and send to RFT3100 IC on four lines TX_I, TX_Q, TX_IN and TX_QN. This modulates on the TX IF (QPSK Modulation) 228.6Mhz (263.6Mhz for PCS).

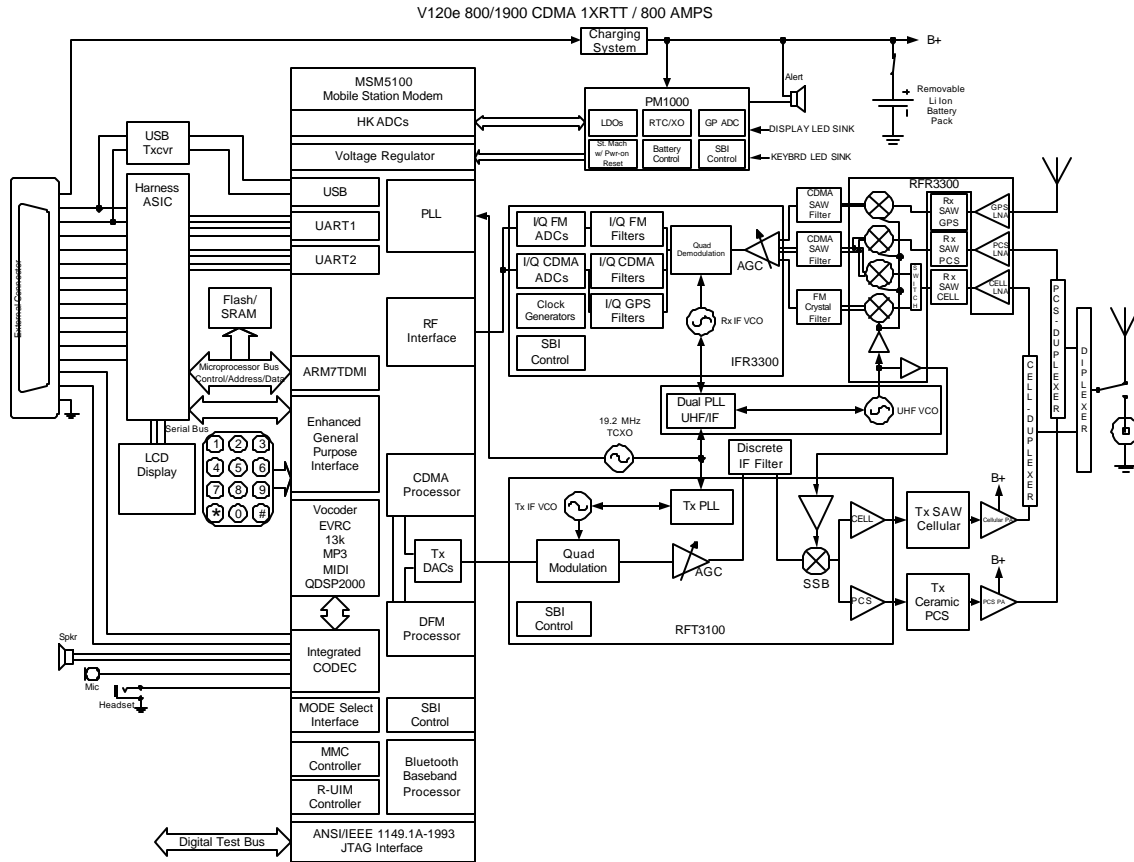

MDM - 6/17/2002
Version 0.1

Figure 1: Motorola MSM5100 System Block Diagram

For the receive data path (Rx), the RFR3100 down converts the received RF signal of the intermediate frequency (IF). The IFR3000 converts the modulated IF signal from the RFR3100 into digital baseband data. Finally, the MSM5105 demodulates Rx digital baseband data from the IFR3000.

For the transmit data path (Tx), the MSM5105 modulates, interpolates, and converts the digital signal into an analog baseband before sending it to the RFT3100. The RFT3100 up converts the Tx analog baseband into RF. The MSM5105 communicates with the external RF and analog baseband to control signal gain in the RF Rx and Tx signal paths, reduce baseband offset errors, and tune the system frequency reference.

QUALCOMM also supplies system software and development tools to minimize the development time of a subscriber unit. With the release of the MSM5105, a new, optimized version of Dual Mode Subscriber Software (DMSS) is available with device driver support for the new functionality of the MSM5105. Additionally, the Subscriber Unit ReFERENCE design (SURF) offers a baseline hardware platform for additional software

RF SIDE BLOCK DIAGRAM

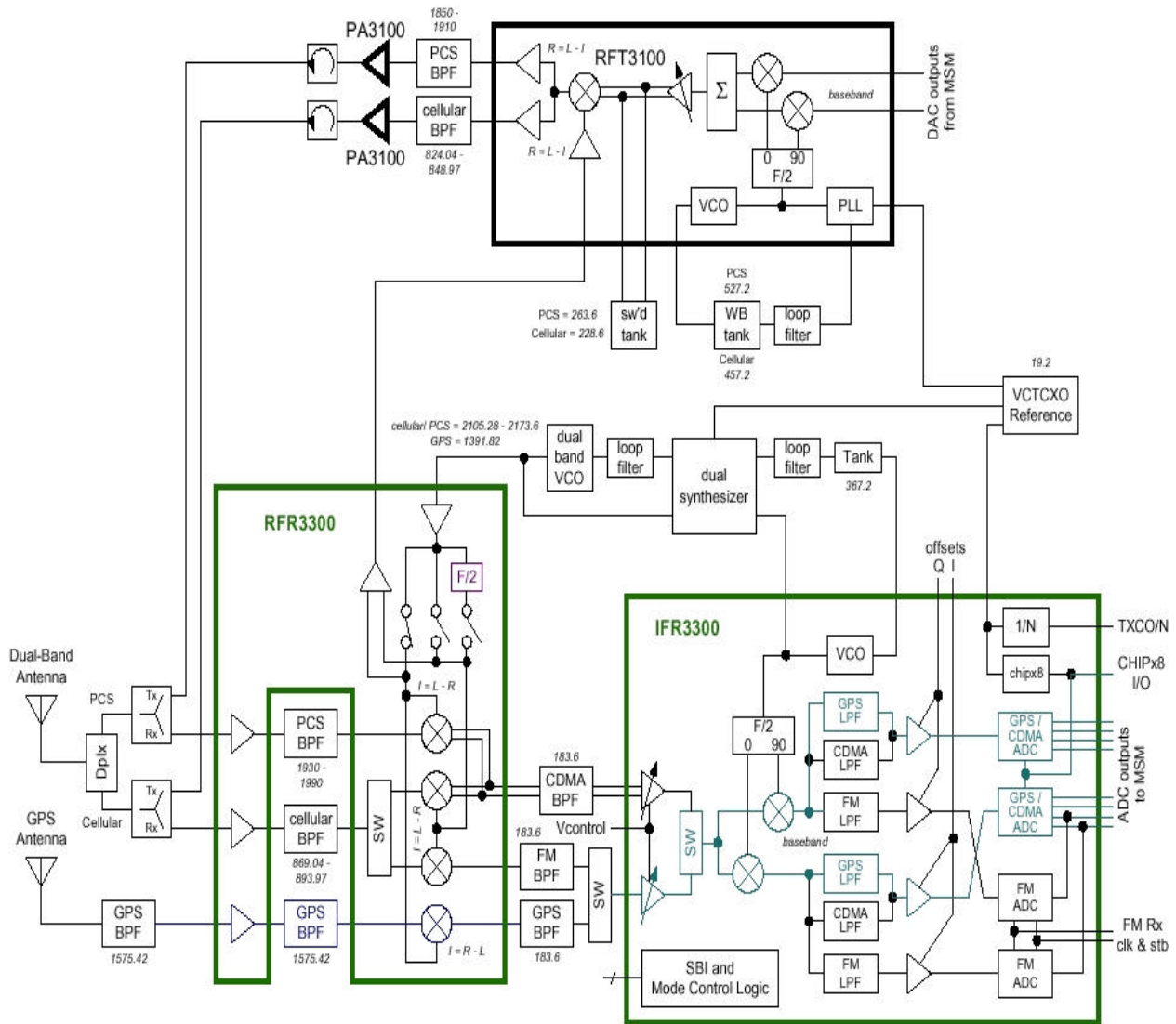

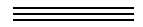
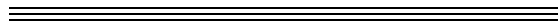

This Page is intentionally left blank.



Disassembly

Introduction

Care must be taken during the disassembly and reassembly of the unit in order to avoid damaging or stressing the housing and internal components. Ensure that a properly grounded high impedance conductive wrist strap is used while performing these procedures on electronic units.

Recommended Tools

The following tools are recommended for use during the disassembly and reassembly of the phone.

- Anti-Static Mat 6680387A95
- Ground Cord 6680334B36
- Wrist Band 4280385A59
- Plastic Prying Tool SLN7223A
- Rear Housing Removal Tool
- Dental Pick
- Tweezers
- T6 Torque Screw Driver

CAUTION

Many of the integrated circuit devices used in this equipment are vulnerable to damage from static charges. An anti-static wrist band, connected to an anti-static (conductive) work surface, must be worn during all phases of disassembly, repair, and reassembly.

Disassembly Procedure

Refer to the disassembly instructions and photo sequence on the following pages.

Assembly Procedure

Once the unit is disassembled and the repair is carried out it then becomes obvious that to

assemble the unit, the procedure is the reverse of that previously completed for disassembly.

Rear Housing Removal:

Using a Torx (T-6) screw driver unscrew all the 6 screws. Gently remove the Rear Housing as shown.



Board Removal:

The six screw bosses hold the board in place. Remove the board as shown.

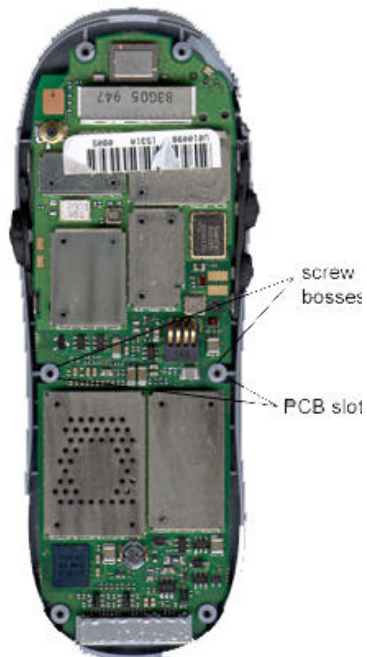

Board Removal



Display Removal:

The elastomeric on the display makes contact with the power contacts on the PCB. The two locating pins on the display are aligned and the four holding tabs are grabbing the board. Make sure you release the tabs and gently lift the display. Once you free the tabs on one side, the other side comes off easily.

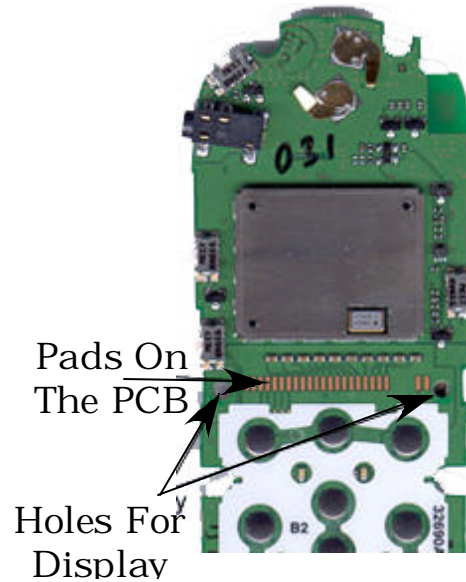
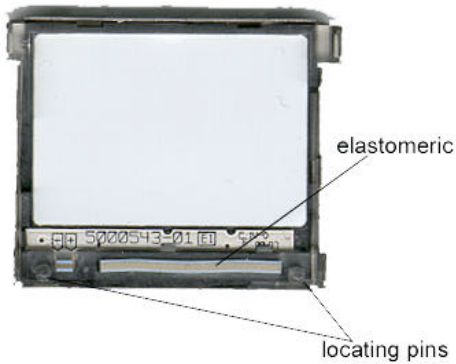

Caution: To prevent over bending the display latches, keep fingerprints off the display viewing area.



Keypad Removal:

Remove the keypad from the front housing as shown.



Speaker Removal:

There is a adhesive backing to the speaker, hence make sure you pry the speaker open by the help of a bezel stick.



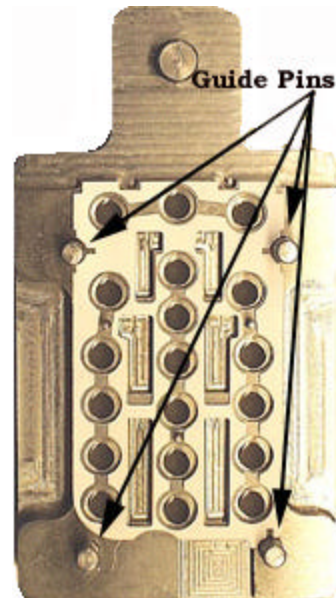
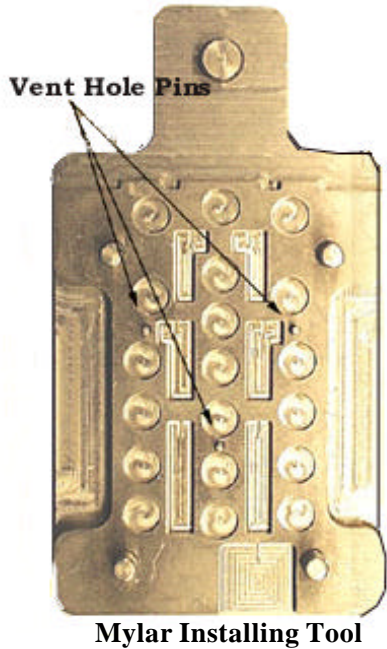

Acoustic Gasket, Power Button, VR Button Volume Buttons and Display Gasket Button Removal:

All of the above accessories are placed in their respective places and are easily removable.

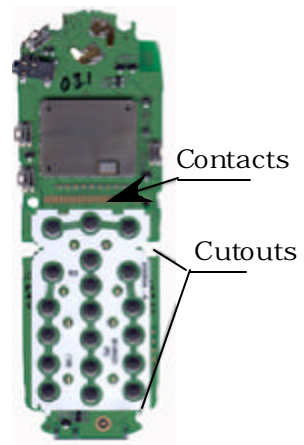

Mylar Placed on the Board

120e PRODUCT SUPPORT TOOLS

FLASHING/FLEXING/NAM PROGRAMMING

V120e is a Qualcomm chipse based and it uses the 17 pin CE Bus Connector which uses the RS232 & USB communication protocols. The following are the hardware and software requirements:

1. Personal computer with
2. PST 3.6 software Motorola test interface adapter box (junior board) -
3. SYN8400A Interface adapter power supply –
4. SPN4029A or Wall charger
5. SPN4278D CE Bus cable
6. SKN6304B Serial & USB cable same as used for V120 P2K

About Junior board operation:

V 120e will support both USB & Serial communication. However at this time of release only serial communication is functional. 120e uses the V2260 Rf Cable adaptor part # 288792Ok01 which is used for all Rf Phasing and testing.

Junior Board Switch Positions

MODE Selection	1	2	3	4	5	6	7	8
V120x	Up	Up	Up	Up	Down	Up	Up	Up

SYN8400A – JUNIOR BOARD

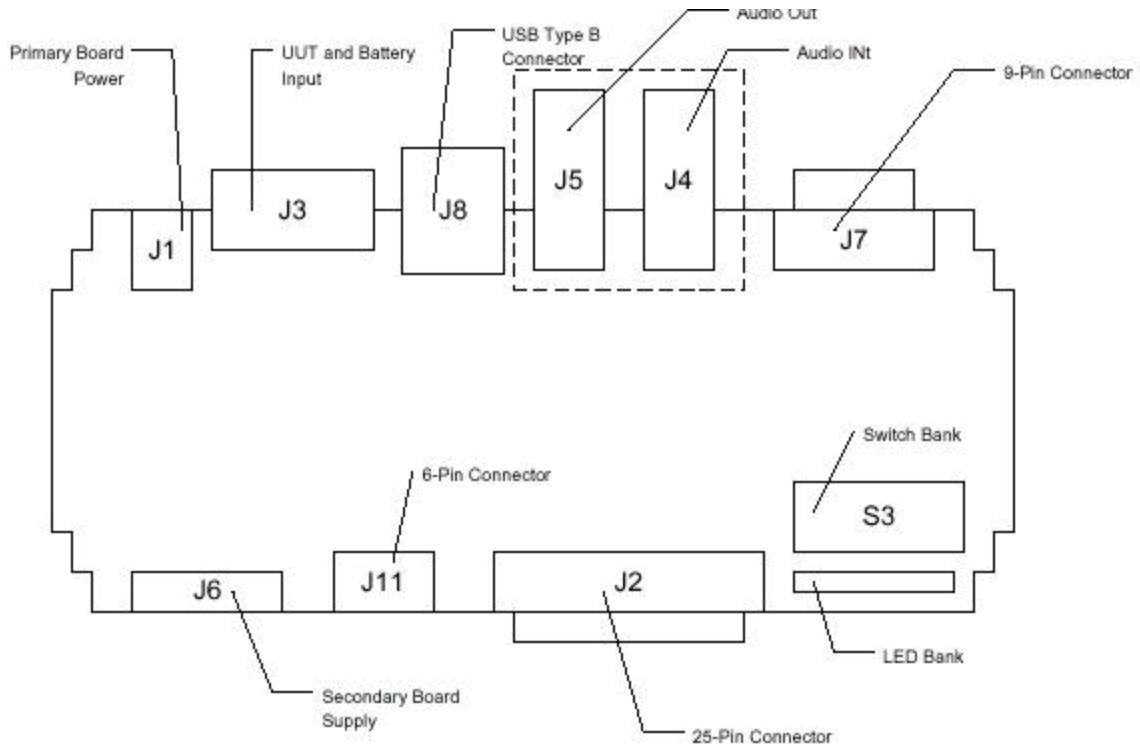

JUNIOR BOX SETUP

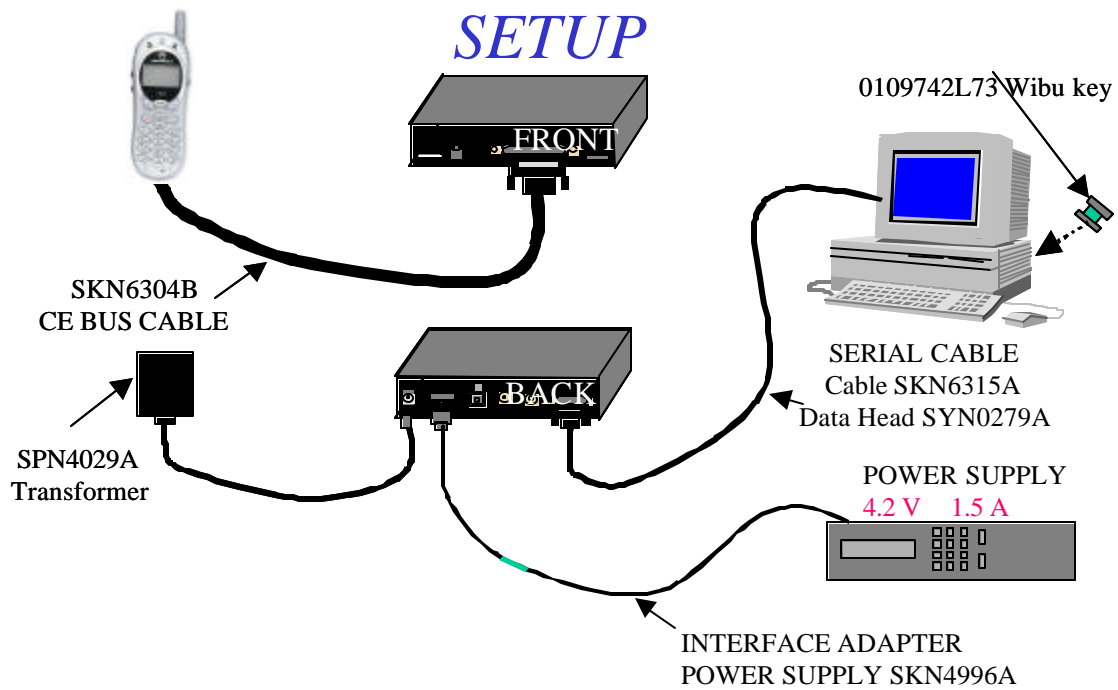

TEST AND PHASING

Gate 24 supports the testing and phasing of V120x product, For more details on Test and Phasing contact International Service Engineering ISE-CDMA

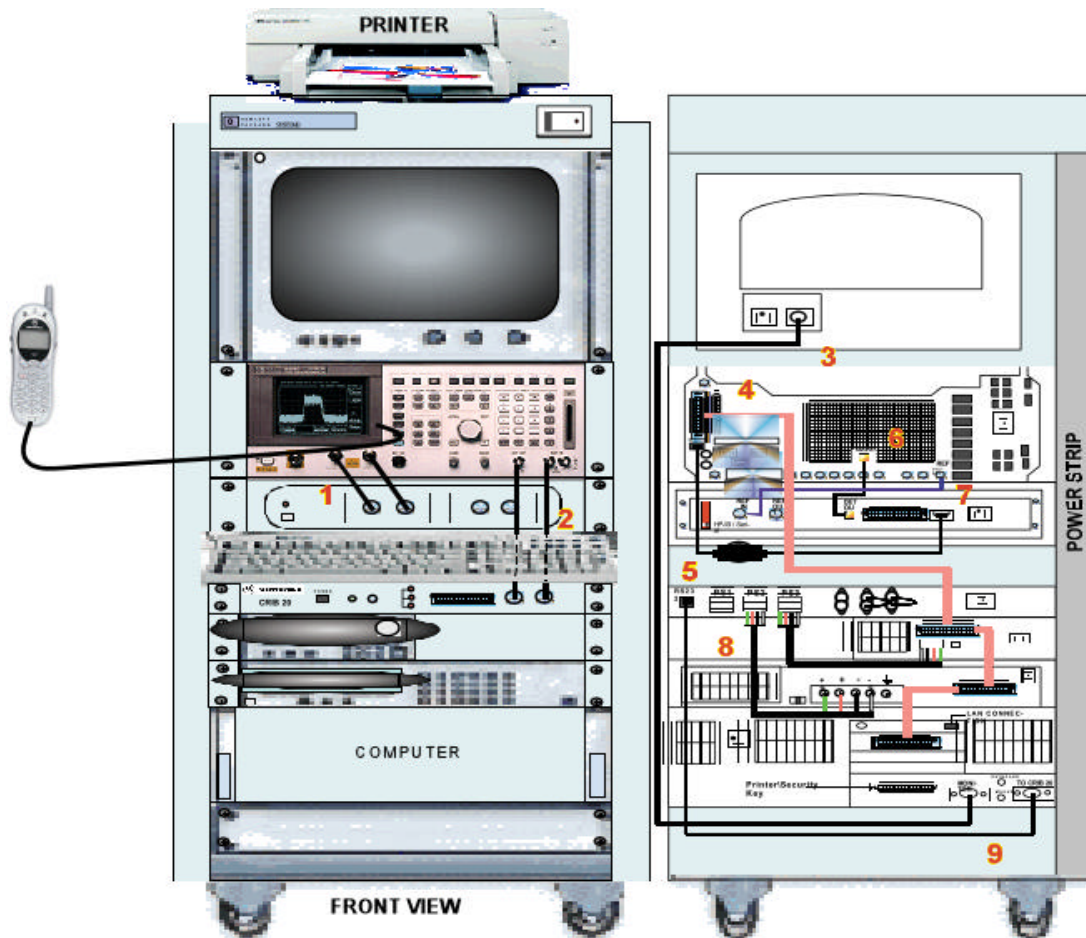

RF Cable Test

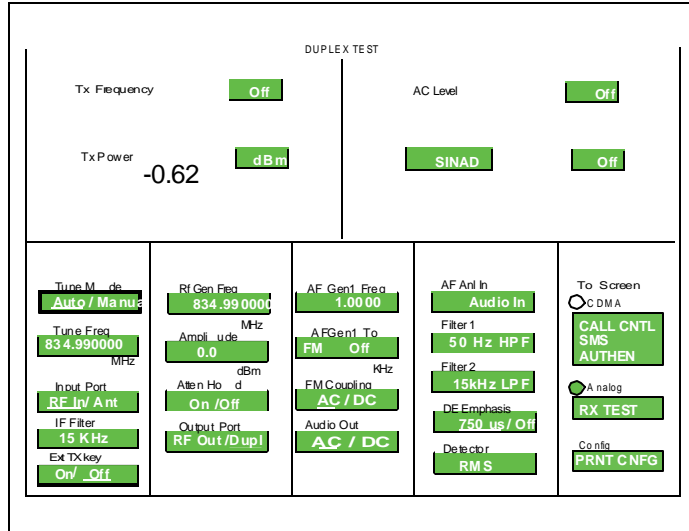

To test the RF cable for proper loss:

- ï Tune Freq should be set to TX frequency: 834.990000 MHz.
- ï RF Gen Freq should be set to same frequency (834.990000 MHz).
- ï Tx Power should be set to read in dBm, not Watts.

In order to properly measure and adjust the parameters of a telephone, it is important that you use RF cabling that has minimal loss. Therefore, it is important that you test the RF cable for proper loss. This can easily be done by using the DUPLEX TEST screen of your HP8924. To test the cable, set up the DUPLEX screen as shown above.

Action:

Take the cable under test and connect it from the RF in/out port to the Duplex Out port. At this point you will be getting some type of power reading for cable loss.

Good range: -.2 dBm through -.8 dBm

Bad cable: More than -.8 dBm

If the reading you are getting shows gain (positive number), you may need to zero the power meter. This may happen on an HP8924 whose

memory has just been cleared.

To zero the meter, press the **TX** button on the 8924 panel. Bring the cursor down to the field under **TX Pwr Zero** where it reads **Zero**. Tap the cursor on the Zero field and it will highlight for a moment as it zeroes the meter. Set up the screen as shown above, and test your cable.

Set up for Analog call

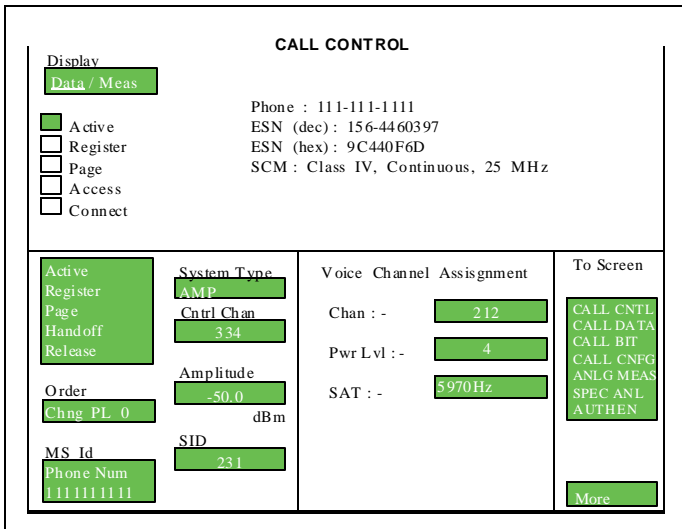

Select **CALL CTRL** from the ANALOG SCRNS Control panel

- ï Select System type: **AMPS**
- ïZero the RF Power meter in the: **Call Config Screen**
- ïSet Amplitude to: **-50 dBm**
- ïSet SID: **Your phoneís System ID**
- ïSelect: **Active**
- ï **Voice Channel Assignment Type:**
- ïChan: **212**
- ïPwr Lvl: **4**
- ï S A T **5970Hz**

Registration

- Put the Test Set in Active state by selecting **Active** from the list on the left side of the screen.
- Select **Data** from the **Data/Meas** field. This is the default mode.
- Select **Register** from the list to register phone.
- If the registration message has been received, the Test Set will display registration data in the upper half of the screen as shown in the sample screen above.

Page

- Select page from the list on the left side of the screen.
- If the mobile responds, you will see the **Access** annunciator light briefly.
- Answer the call by raising the flip or press **SEND** on the mobile to start the conversation.
- The **Connect** annunciator lights. This is the **Connect** state.

Origination

- Dial the desired phone number on the mobile station and press **SEND**.
- The **Access** annunciator will light while the Test Set signals the mobile on the assigned voice channel.
- The **connect** annunciator will light if the mobile properly signals the Test Set.

RX Sensitivity Test (SINAD)

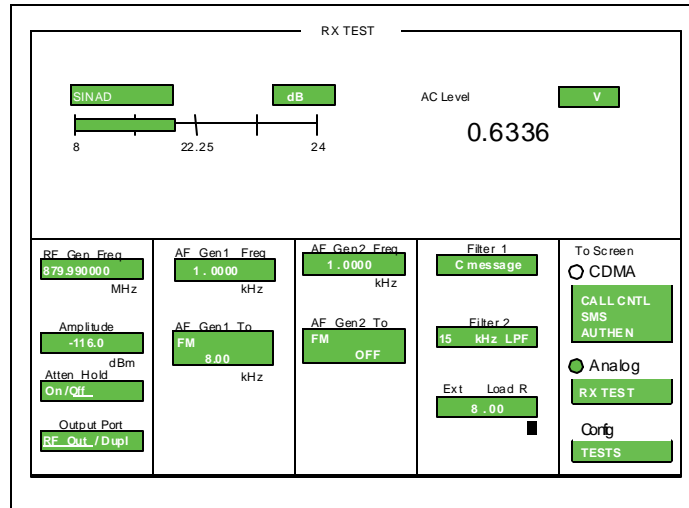

Communications Analyzer Setup:

- Select **RX** button from the Analog Screen Control panel
- Set **RX** frequency to **880.05 MHz**
- Set **Amplitude** to **-116 dBm**
- Set **AF gen1** to **1 kHz** frequency at **8 kHz** deviation, using **FM modulation** (PLEASE NOTE: this is for AMPS only; NAMPS uses much lower deviation)
- Set **AF Filter 1** set to **C message filtering**
- Set **AF Filter 2** to **15 kHz**

Test Mode Commands:

Using RadioComm software (Please refer to the RadioComm Test Procedure)

- Suspend Radio
- Load synthesizer to channel 350
- Unmute receiver audio path
- Turn on compander
- Set volume control to level 4
- Set RX audio path to Ext. path

Sinad measured on the communications analyzer must be more than 12dB.

Duplex SINAD can be measured with the same setting "SET_RF_PWR to lv 2 and turn "CARRIER" on using RadioComm, which turns on the transmitter at power step 2.

TX Power Out Test

TX TEST				
TX Frequency	MHz	FM Deviation	KHz	
834.9900		11.58		
TX Power	dB	AF Freq	KHz	
27.60		1.00000		
Tune Mode	Input Port	AFA nI n	AFGenI Freq	To Screen
Auto/Manual	RE.ir/Ant	FM Demod	1.0000	<input type="radio"/> CDMA
Tune Freq	IF Filter	Filter 1	KHz	CALL CNTL
834.990000	230 kHz	50 Hz H PF		SMS
TX Pwr Zero	Ext TX Key	Filter 2	AFGenI Lvl	AUTHEN
Zero	On/Off	15 kHz L PF	6.00	<input checked="" type="radio"/> Analog
		De-Emphasis	V	RX TEST
		750 .s /Off		Config
		Detector		TESTS
		Pk+- Max		

Communications Analyzer Setup:

- Select TX button from the Screen Control panel
- PWR is measured in dBm
- Set Frequency Measurement to auto or manual (display will show TX Freq. Error)
- Set TX frequency to 835.05 MHz
- Set IF filter to 230 kHz
- Set AF Filter 1 to 50 Hz
- Set AF Filter 2 to 15 kHz
- Set AF gen1 for 1 kHz frequency at 6V level (output will go to the audio port)

Test Mode Commands:

Using RadioComm software (Please refer to the RadioComm Test Procedure)

- Suspend Radio
- Load synthesizer to channel 350
- Set power level to step X, where X is a power level from 1 to 7
- Turn on Carrier

The TX Power Out specification for each portable power level is as follows:

- Power Step 225dBm - 29dBm
- Power Step 321.5dBm - 25.5dBm
- Power Step 417.5dBm - 21.5dBm
- Power Step 513.5dBm - 17.5dBm
- Power Step 69.5dBm - 13.5dBm
- Power Step 75.3dBm - 9.5dBm

Note: When taking measurements, remember to compensate for cable loss.

TX Frequency Error Test

TX TEST				
TX Frequency		FM Deviation		
834.9900		11.58		
TX Power		AF Freq		
27.60		1.00000		
Tune Mode	Input Port	AF Anl In	AFGen1 Freq	To Screen
Auto/Manual	RF in/Ant	EM Demod	1.0000 KHz	<input type="radio"/> CDMA
Tune Freq	IF Filter	Filter 1	AFGen1 Lvl	<input type="radio"/> CALL CNTL
834.990000	230 kHz	50 Hz HPF	6.00	<input type="radio"/> SMS
TX Pwr Zero	Ext TX Key	Filter 2		<input checked="" type="radio"/> Analog
Zero	On/Off	15 kHz LPF		<input type="radio"/> RX TEST
		De-Emphasis		Config
		750. s/Off		TESTS
		Detector		
		Pk+ - Max		

Communications Analyzer Setup:

- Select TX button from the Analog Screen Control panel
- PWR is measured idBm
- Set Frequency Measurement to auto or manual (display will show TX Freq. Error)
- Set TX frequency to 835.05 MHz
- Set IF filter to 230 kHz
- Set AF Filter 1 to 50 Hz
- Set AF Filter 2 to 15 kHz
- Set AF gen1 for 1 kHz frequency at 6V level (output will go to the audio port)

Test Mode Commands:

Using RadioComm software (Please refer to the RadioComm Test Procedure)

- Suspend Radio
- Load synthesizer to channel 350
- Set power level to step 2,
- Turn on Carrier

The frequency error measured on the communications analyzer must be less than **±1 kHz**.

TX Maximum Deviation Test

TX TEST				
TX Frequency <input type="text" value="834.9900"/> MHz		FM Deviation <input type="text" value="11.58"/> KHz		
TX Power <input type="text" value="27.60"/> dB		AF Freq <input type="text" value="1.00000"/> KHz		
Tune Mode <input type="text" value="Auto/Manual"/>	Input Port <input type="text" value="RE in/Ant"/>	AF Anl In <input type="text" value="FM Demod"/>	AFGen1 Freq <input type="text" value="1.0000"/> KHz	To Screen <input type="radio"/> CDMA
Tune Freq <input type="text" value="834.990000"/>	IF Filter <input type="text" value="230 kHz"/>	Filter 1 <input type="text" value="50 Hz HPF"/>	AFGen1 Lvl <input type="text" value="6.00"/> V	<input type="checkbox"/> CALL CNTL <input type="checkbox"/> SMS <input type="checkbox"/> AUTHEN
TX Pwr Zero <input type="text" value="Zero"/>	Ext TX Key <input type="text" value="On/Off"/>	Filter 2 <input type="text" value="1.5kHz LPE"/>		<input checked="" type="radio"/> Analog
		De-Emphasis <input type="text" value="750 us/Off"/>		<input type="text" value="RX TEST"/>
		Detector <input type="text" value="Pk+-Max"/>		Config <input type="text" value="TESTS"/>

Communications Analyzer Setup:

- Select TX button from the Analog Screen Control panel
- PWR is measured in dBm
- Set Frequency Measurement to auto or manual (display will show TX Freq. Error)
- Set TX frequency to 835.05 MHz
- Set IF filter to 230 kHz
- Set AF Filter 1 to 50 Hz
- Set AF Filter 2 to 15 kHz
- Set AF gen1 for 1 kHz frequency at 6V level (output will go to the audio port)

Test Mode Commands:

Using RadioComm software (Please refer to the RadioComm Test Procedure)

- Suspend Radio
- Load synthesizer to channel 350
- Set power level to power step 2,
- Turn on Carrier
- Select External TX audio path
- Unmute TX Audio path
- Turn on compandor

View FM Deviation for reading.

TX Maximum Deviation Pass Specifications: **9.8 kHz - 12 kHz**

TX SAT Deviation Test

TX TEST				
TX Frequency		FM Deviation		
834.9900		1.890		
TX Power		AF Freq		
27.60		6.00000		
Tune Mode	Input Port	AF Anl In	AFGen1 Freq	To Screen
Auto/Manual	RF in/ Ant	FM Demod	1.0000 KHz	<input type="radio"/> CDMA
Tune Freq	IF Filter	Filter 1	AFGen1 Lvl	<input type="radio"/> CALL CNTL
834.990000	230 kHz	50 Hz HPF	6.00	<input type="radio"/> SMS
TX Pwr Zero	Ext TX Key	Filter 2		<input checked="" type="radio"/> Analog
Zero	On/Off	15 kHz LPF		<input type="radio"/> RX TEST
		De-Emphasis		Config
		750 .s/Off		TESTS
		Detector		
		Pk+ - Max		

Communications Analyzer Setup:

- Select **TX** button from the Analog Screen Control panel
- **PWR** is measured in **dBm**
- Set **Frequency Measurement** to **auto or manual** (display will show TX Freq. Error)
- Set **TX frequency** to **835.05 MHz**
- Set **IF filter** to **230 kHz**
- Set **AF Filter 1** to **50 Hz**
- Set **AF Filter 2** to **15 kHz**
- Set **AF gen1** for **1 kHz frequency** at **6V** level (output will go to the audio port)

Test Mode Commands:

Using RadioComm software (Please refer to the RadioComm Test Procedure)

- Suspend Radio
- Load synthesizer to channel 350
- Set power level to power step 2,
- Turn on Carrier
- Enable 6000 Hz SAT tone

View FM Deviation for the reading.

The transponded peak SAT FM deviation should be **2 kHz ±200 Hz**.

The demodulated signal on the communications analyzer should have an audio frequency of **6000 Hz**.

TX ST Deviation Test

TX TEST				
TX Frequency <input type="text" value="834.9900"/> MHz		FM Deviation <input type="text" value="7.890"/> kHz		
TX Power <input type="text" value="27.60"/> dB		AF Freq <input type="text" value="10.0000"/> kHz		
Tune Mode <input type="text" value="Auto/Manual"/>	Input Port <input type="text" value="RE_in/Ant"/>	AF Anl In <input type="text" value="EM Demod"/>	AFGen1 Freq <input type="text" value="1.0000"/> kHz	To Screen <input type="radio"/> CDMA
Tune Freq <input type="text" value="834.990000"/>	IF Filter <input type="text" value="230 kHz"/>	Filter 1 <input type="text" value="50 Hz HPF"/>	AFGen1 Lvl <input type="text" value="6.00"/> V	<input type="radio"/> CALL CNTL
TX Pwr Zero <input type="text" value="Zero"/>	Ext TX Key <input type="text" value="On/Off"/>	Filter 2 <input type="text" value="15 kHz LPF"/>		<input checked="" type="radio"/> Analog
		De-Emphasis <input type="text" value="750_s/Off"/>		<input type="text" value="RX TEST"/>
		Detector <input type="text" value="Pk+ - Max"/>		Config <input type="text" value="TESTS"/>

Communications Analyzer Setup:

- Select TX button from the Analog Screen Control panel
- PWR is measured in dBm
- Set Frequency Measurement to auto or manual (display will show TX Freq. Error)
- Set TX frequency to 835.05 MHz
- Set IF filter to 230 kHz
- Set AF Filter 1 to 50 Hz
- Set AF Filter 2 to 15 kHz
- Set AF gen1 for 1 kHz frequency at 6V level (output will go to the audio port)

Test Mode Commands:

Using RadioComm software (Please refer to the RadioComm Test Procedure)

- Suspend Radio
- Load synthesizer to channel 350
- Set power level to power step 2,
- Turn on Carrier
- Enable signaling tone

View FM Deviation for reading.

The peak ST deviation measured on the communications analyzer should be **8 kHz ±800 Hz** deviation.

The demodulated signal on the communications analyzer should have an audio frequency of **10 kHz**.

Set up for CDMA call

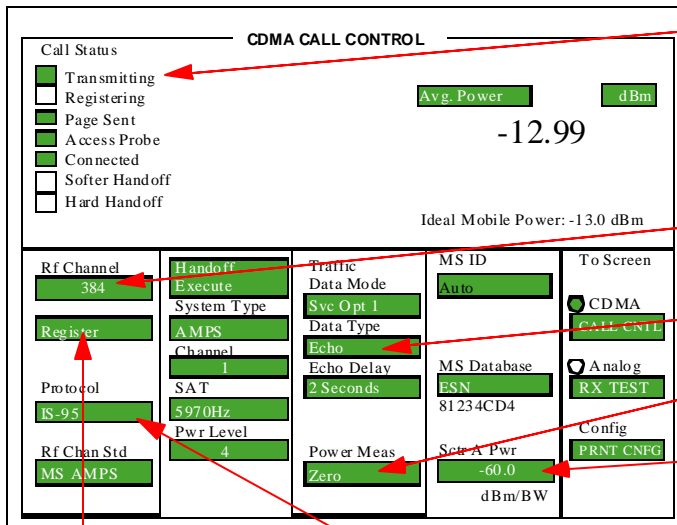

Pseudo LED's show call Status

The "Transmitting" light means that the HP 8924C is configured and transmitting the required CDMA signals to make a call.

Enter the expected RF channel number

Select Echo Mode

Zero the Power Meter

Set CDMA Generator Power to -60 dBm/1.23MHz

Select Protocol

Once the Phone Acquires Service, Register it by Using the Knob

1. Enter the channel number that the CDMA phone expects to find a CDMA system on. The IS-95A standard defines a primary and secondary channel number for both the A and B service providers. These channels are: 283 and 691 for the A side, and 384 and 777 for the B side. A CDMA phone will only look for a CDMA system on power-up at its programmed primary or secondary channels. The HP 8924C defaults to channel 384. The phone you are using is set to B side service with a primary channel of 384.
2. Select the necessary protocol (IS-95, ID-95A, J-STD-008). For this demo we select IS-95.
3. Select the Traffic Data Mode to Service Option 001 (duplexed voice mode).
4. Set the Data Type to echo. This will allow you to speak into the phone under test and hear the voice quality echoed in the phone via the CDMA link from the HP 8924C.
5. Zero the average power detector. This is a good time to perform this step since no power is being transmitted by the phone.
6. Finally, set the Sector A power to -60 Dbm/ 1.23 MHz. You are now ready to make a CDMA phone call.
7. Make sure that the phone has acquired service (some type of display indicator on the phone).
8. Register the phone. This step is not required for mobile initiated calls. When registration is successful, the Registration Indicator will go out. The MS database should now show an ESN value.

Making a CDMA Phone Call

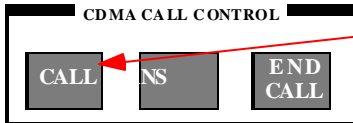

Press the front panel "CALL" key to initiate a CDMA call.

Answer the call on the CDMA Phone. Then speak into the phone and wait to hear your voice echoed back to you by the HP8924C.

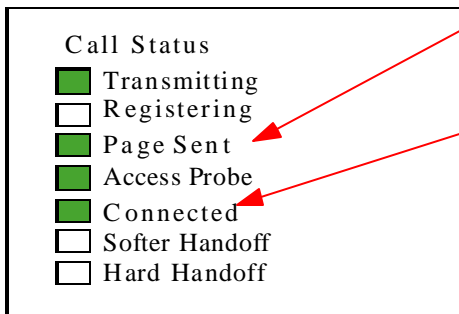

Each light activates as the call processing proceeds.

The "Connected" light indicates that the call was successfully completed.

1. Press the HP 8924C's CALL button.
2. Notice the call status indicators are activated at each step in the call process. First the PAGE indicator activates when the HP 8924C sends out a page message on its paging channel. When the mobile answers with an access probe, the access probe indicator is activated.
3. The phone will now ring, or indicate on its display there is an incoming call.
4. To complete the call, press the send key on the phone. The connected indicator should now be on. When the HP 8924C receives an acknowledgment from the phone that the traffic channel connection process is completed, the connected indicator is activated.

Set up for CDMA RF Parametric Measurements

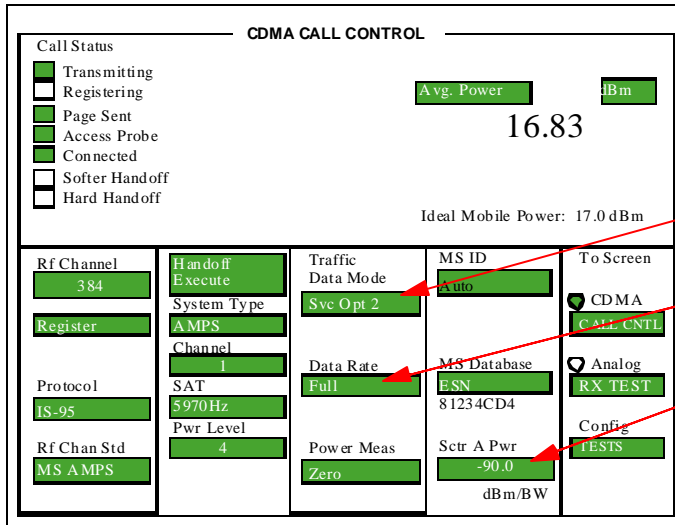

Setup a CDMA Call with the following parameters:

Traffic Data Mode:

Service Option 2

•Data Rate:

Full

•Set Sector A's power:

-90 dBm/1.23 MHz

•Press the front panel "CALL" key

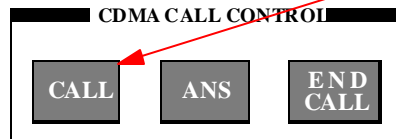

While service option 001 calls are useful for the verification of CDMA mobile functionality, parametric tests cannot be accurately made in this mode. The TIA IS-98A minimum performance standard recommends that testing be made using service option 002. In service option 002, the mobile under test demodulates the received signal and then re-transmits this data to the HP 8924C. This mode allow accurate receiver performance measurements.

To make a service option 002 call:

1. Press the **END CALL** front panel key to terminate the service option 001 call.
2. Return to the CDMA Call Control screen.
3. Change the Traffic Data Mode to Service Option 002.

4. Make sure that the Data Rate is set to Full.
5. Set Sector A's power to -90 dBm/1.23 MHz (this value may need some adjustment for varying cable losses - some phones with their associate fixtures may require higher levels due to path losses to make a phone call).
6. Press the HP 8924C's front panel CALL button.

The HP 8924C's call status indicators should now indicate that a call is connected. Depending on the phone being used, either SO2 or Loop-back will be shown on the phone's display. Also available is service option 03 (voice EVRC), along with service option 09 and service option 32768 for 14.4 vocoder type phones.

Making a Receiver Sensitivity Measurement

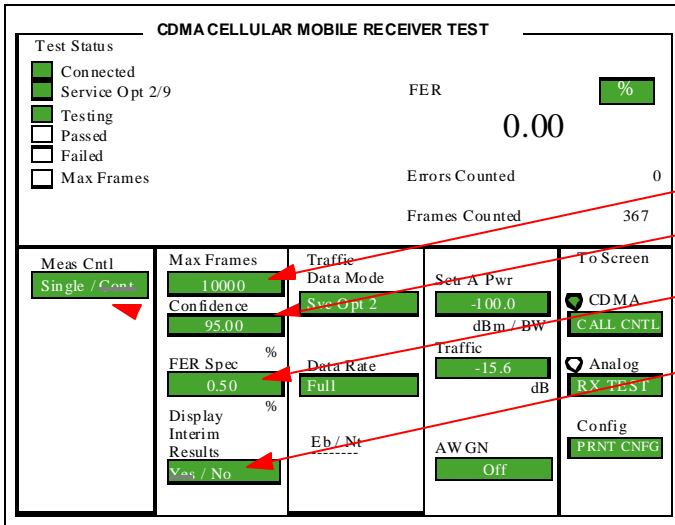

To make an FER Measurement:

- Enter the Maximum number of frames to Test: 10,000
- Enter the Confidence: 95%
- Enter the Target FER Specification: 0.5%
- Enable the display of interim results: Yes

Arm the Measurement

- Place the cursor at the “Cont” field under Meas Cntl
- Push the Knob

Now that you have a service option 002 call connected, you are ready to make parametric receiver and transmitter measurements. To perform receiver measurements:

- 1.Go to the **RX Test screen**
- 2.Notice that the RX Test screen also has call status indicators that show if the call is still connected and if the call is a service option 002 call.
- 3.The parameter used to evaluate CDMA receiver quality is frame-error-rate. To setup a FER measurement with the HP 8924C, you need to enter three parameters: Max Frames, Confidence, and FER Spec.
- 4.Enter 10,000 into the Max frames field. This sets an upper bound to the time limit of the test.

- 5.Enter 95% into the Confidence field. This field sets the desired confidence limit for the test. If confidence limit testing is not desired, you can turn this field off. In that case, the FET test will run until the number of frames tested reaches the value entered into the Max Frames field.
- 6.Enter 0.5% into the FER spec field. This field sets the desired FER specification to test to.
- 7.Make sure that the Display Interim Results field is set to yes.
- 8.Use the knob to place the cursor in front of the Arm field. Press the knob to start the measurement.

Receiver Test Termination

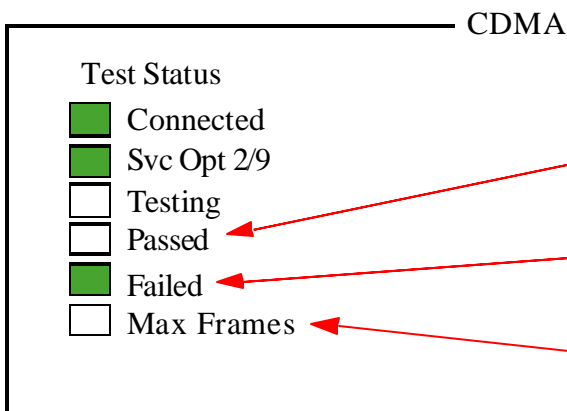

There are 3 possible outcomes to an FER Test:

- Passed:** this means that the measured FER meets the target FER specification with the specified confidence.
- Failed:** this means that the measured FER does not meet the target FER specification with the specified confidence.
- Max Frames:** this means that the test was indeterminate in that the measured FER could neither pass nor fail the target FER specification with the specific confidence in the number of frames specified.

There are three possible outcomes for a confidence interval receiver frame-error-rate test with the HP 8924C:

1. When the HP 8924C determines that the measured FER will meet the user specified FER specification with the specified confidence level, the test is halted and the Passed indicator is activated.
2. The HP 8924C extends the TIA recommendation to also check for failures with the user specified confidence level. In other words, if the HP 8924C detects that the measured FER will fail the user entered FER specification with the specified confidence level, the test is halted and the Failed indicator is activated. This feature eliminates wasted time testing phones that are clearly failing the test.
3. If neither the pass or fail conditions are met, the FER test will run until the number of frames counted equals the value entered into the Max Frames field. When this occurs, the Max Frames indicator is activated. If the confidence interval is turned off, the HP 8924C does not perform any confidence level checking and the FER test will run until the number of frames tested equals Max Frames.

CDMA Transmitter Tests

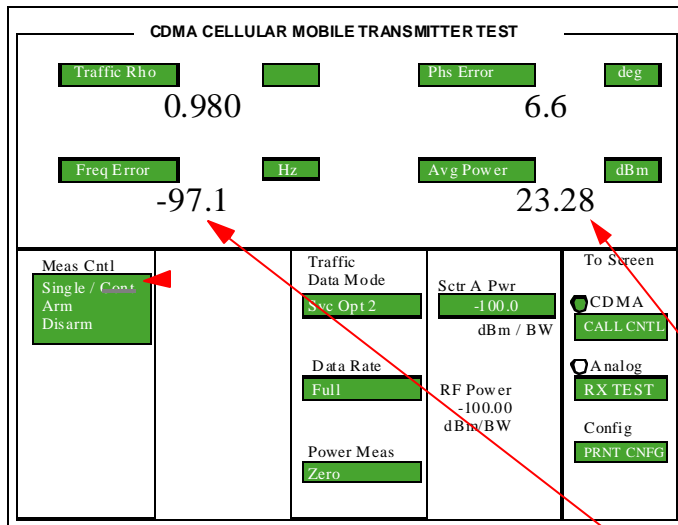

To make Concurrent RX and TX Measurements:

- Restart FER with Confidence Limits Off
- Go to the TX Test Screen
- Switch to Continuous Measurements

Read Average Power

- Check Max Power
- Check Open Loop Power Control

Read Rho Measurements

- Waveform Quality
- Frequency Error
- Amplitude & Phase Error

Simultaneous and transmitter tests is another feature of the HP 8924C. Simultaneous measurements results in much reduced test time. To make simultaneous receiver sensitivity and transmitter measurements:

1. Go to the TX test screen. (Press TX Test under the CDMA screens area.)
2. Make sure that the Meas Cntl is in Continuous mode. The HP 8924C will now make TX measurements.
3. Now select several measurement field and change the measurement types. Note: TM Rho (Test Mode Rho) only works with phones that have Test Mode functionality.

Now switch back to the RX Test screen. Notice that the FER test continued to run while you were making TX measurements.

CDMA Transmitter Power Range Test

CDMA TRANSMITTER POWER RANGE TEST				
Max Power 25.46 dBm		Avg Power 1.54 dBm		
Min Power -54.42 dBm		Ideal Mobile Power: 1.6 dBm		
Meas Cntl Execute	Closed Loop Pwr Cntl Closed Loop Change n down Steps 50 Execute Drop Timer On / Off	Traffic Data Mode Svc Opt 2 Data Rate Full Power Meas Zero	Sctr A Pwr -75.0 dBm / BW Traffic -15.6 dB Atten Hold On / Off	To Screen <input checked="" type="radio"/> CDMA CALL CNTL <input type="radio"/> Analog RX TEST Config PRNT CNFG

Select Execute

The ability to do min/max power measurements just by selecting Execute is another advanced feature of the HP 8924C. In this screen you can also control and test each power step while comparing Ideal Mobile Power to actual Avg Power measurements.

1. Go to the CDMA Transmitter Power Range Test screen (press the blue Shift key and then the Range key).
2. Now execute the min/max power measurement (use the knob and select execute under the min/max power field).
3. You will also notice in this screen you can select closed-loop power control to manually control power settings of the phone. Note: If "always down" is selected, the phone will step its power down until the call is lost. If power control is changed, be sure to return it to "closed-loop" before proceeding onto the next test.

FER with AWGN Tests

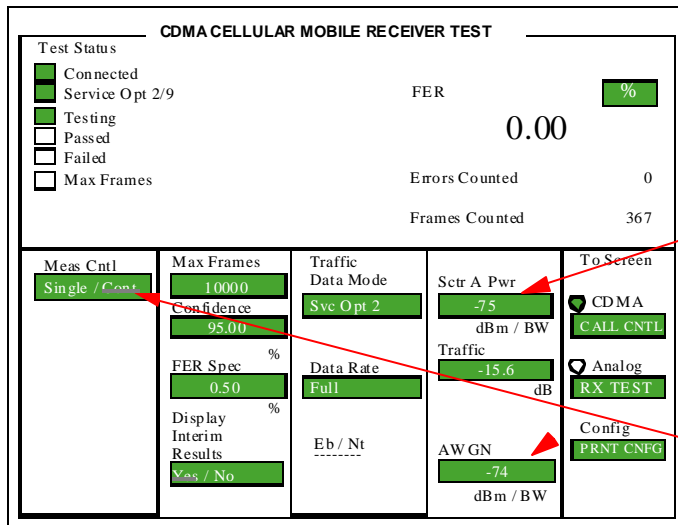

To make a CDMA FER with AWGN measurement:

- Use the same setup as for the receiver sensitivity test
- Set Sector A Power to -75 dBm/1.23 MHz
- Set AWGN Power to -74 dBm/1.23 MHz

Arm the Measurement

- Place the cursor at the “Cont” field under Meas Cntl
- Push the knob

The other key receiver measurement for CDMA phones is the FER with AWGN test. In this test, large amounts of uncorrelated noise is added to simulate the actual conditions encountered by a CDMA phone in actual use. To make this measurement:

- 1.Set the Sector A Power to -55 dBm/1.23 MHz.
- 2.Set the AWGN source to -54 dBm/1,23 MHz (this means that the traffic channel is 16.6 dB below the noise level!).
- 3.Arm the measurement by selecting Continuous in the Meas Cntl field.
- 4.Under these conditions, a CDMA phone should meet 0.5% FER with 95% confidence.

Standards specify other tests for other rates. These can be performed by changing the Data Rate and Traffic level to the specified settings.

V120E-aGPS Testing Procedure

1. Scope

This document is intended for field service center to verify whether GPS is working not for field return units and reworked units. Since the V120E does not have a 50 ohm direct connection for GPS test, alternative methods are proposed here to test the GPS functionality

2. Brief description of GPS implementation on V120E

V120E-aGPS is Qualcomm MSM5100 chipset based handset with assist GPS (Global Position System) functionality. Besides the main antenna for CDMA/AMPS modes, a separate GPS antenna is placed on the handset. GPS antenna is located at the back housing near the belt clip hole. Here is the block diagram of the GPS.

3. GPS functionality test methods

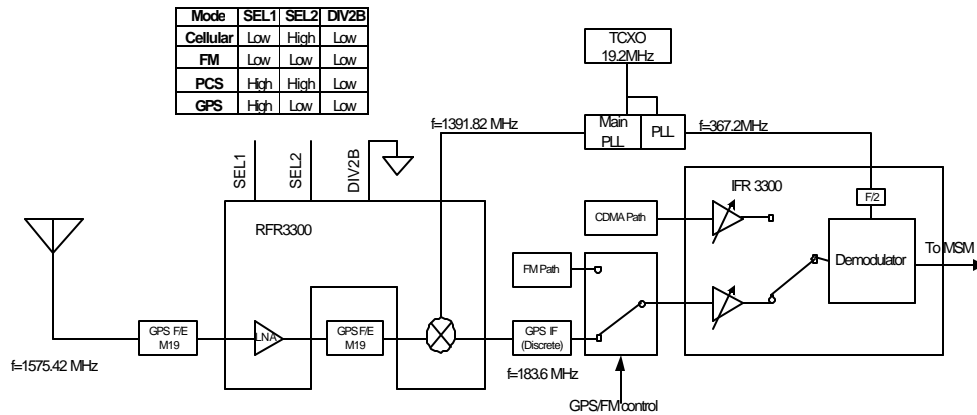

Block Diagram for GPS

Three test methods are recommended here, each test has its own requirement and offers its advantage and disadvantage. Generally, only one test is needed for GPS verification purpose.

3.1 GPS sensitivity test using true GPS satellites

3.1.1 Requirement

- A reliable test fixture that can hold two phones side by side
- A known good phone with full GPS test data
- Test center is within the aGPS coverage

3.1.2 Procedure

- a. Test fixture should be placed in a fixed location and away from any interference source, while satellites are in view
- b. Place the known good phone in the fixture, set the radio to FTS (field test status) screen*; display is now in call status screen. Press right soft key “next” key twice, now screen displays a list of parameters you can modify; Scroll down to “GPS Sess” (GPS Session) using down arrow key, and change it to “cont” by pressing right soft key “change”, so radio is in a mode which will continuously update the GPS data; Scroll down to “Perf Lvl (Performance level), and change it to “6” so radio is in GPS only mode; Scroll down to “Loc Priv” (location privacy), change it to “none”. And then press left soft key “Exit” and “Next” on next screen, radio will automatically go to GPS session screen, now display should show “GPS session In Progress Please wait” message. Once fix is successful, the satellite info will automatically display on screen, otherwise an error message will show on first line of screen. If the fix is successful, press right soft key “SAT”. Screen will then display all satellites info in view. The Satellite info is in the following format

SATELLITE xx/xx (Current instance with total number of satellites)
 PRN: xx (Satellite PRN number)
 Code Ph: xxxx.xxx (Pseudorange measurement)
 C/No: xxxxdB-Hz (Carrier signal to noise ratio)

The useful info here are PRN and C/N0, PRN is satellite ID Which is unique to every satellite, C/N0 is satellite signal strength to Noise (per Hz) at base of antenna. Satellite strength in dBm is C/N0 – 174 (dBm), write PRNs and corresponding satellite strengths (converted from C/N0)

- c. Place the test phone in the fixture, side by side with reference phone. Set the phone to same mode as reference phone, or set phone to continuous fix mode with privacy turned off. Then launch GPS session, write down the PRNs and corresponding satellite strengths
- d. Compare the satellite strength with same PRN number of reference phone and test phone. If the difference of strength is within a limit**, then test phone has good GPS functionality

Note: * please refer to V120E field test guide for instruction

** The test limit is not yet established.

***words in color are either actual info displayed on screen or actual software key name



MOTOROLA

RadioComm

T120e Test Procedure

RadioComm 3.5.1 Service Edition

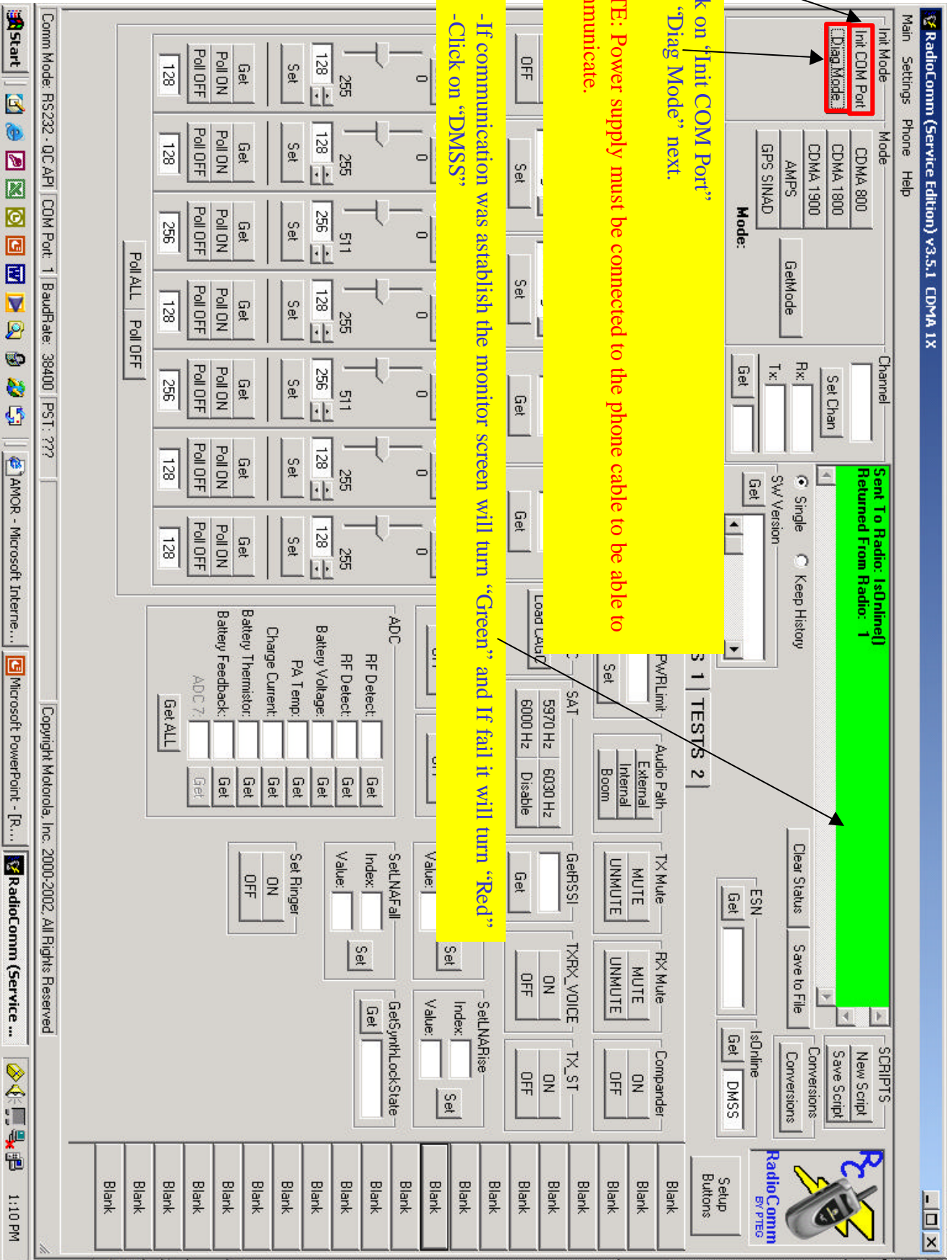

Click on "Init COM Port"
 And "Diag Mode" next.
NOTE: Power supply must be connected to the phone cable to be able to Communicate.

-If communication was established the monitor screen will turn "Green" and if it fails it will turn "Red"
 -Click on "DMSS"

800 CDMA RX TEST SETUP

RadioComm (Service Edition) v3.5.1 CDMA 1X

Main Settings Phone Help

Init Mode: Mode: **CDMA 800** CDMA 1800 CDMA 1900 AMPS GPS SINAD

Channel: Set Chan Rx: Tx: Get

Sw Version: Single Keep History

ESN: Get Save Status Save to File

Conversions:

SCRIPTS:

isOnline:

RadioComm BY PTEG

Select 'SetMode'

TX On/Off: TX W/aveform: Data Rate: TXPWRLimit: Audio Path:

PA On/Off: PA Range: LNA Range: LoadCAGC: SAT: 5970 Hz 6030 Hz 6000 Hz Disable

TX Mute: RX Mute: Comander:

GetRSSI: TXRX_VOICE: TX_ST:

PDM: I Offset: 0 255 Q Offset: 0 255 Tx AGC: 0 511 Rx AGC: 0 255 TRK_LD: 0 511 Tx Comp: 0 255 Rx Comp: 0 255

ADC: RF Detect: RF Detect: Battery Voltage: PA T emp: Charge Current: Battery Thermistor: Battery Feedback: ADC 7:

TXWBD_RVC: RXWBD_FVC:

SetLNAOffset: Index: Value: Set

SetLNAFall: Index: Value: Set

SetLNA Rise: Index: Value: Set

GetSynthLockState:

Set Ringer:

Comm Mode: RS232 - QC API COM Port: 1 BaudRate: 38400 PST: ??? Copyright Motorola, Inc. 2000-2002. All Rights Reserved

Start

AMOR - Microsoft Internet... Microsoft PowerPoint - [R... RadioComm (Service ... 1:25 PM

800 CDMA RX TEST SETUP

RadioComm (Service Edition) v3.5.1 CDMA 1X

Main Settings Phone Help

Init Mode: Init COM Port: CDMA 800
Diag Mode: CDMA 1800
CDMA 1900
AMPS
GPS SIMAD

Channel: 350
GetMode: Rx: 890.5 Tx: 835.5 Sw Version: Single Keep History

Sent To Radio: SetChannel(350)
Returned From Radio: 1

Phone T 1 Phone T 2 DMSS 1 DMSS 2 DMSS 3 NV/SEEM TESTS 1 TESTS 2

Phone T RAM Download: <No File Selected> TX On/Off: ON
Browse: Flash Done TX W/aveform: CDMA CW Data Rate: Full Quarter Half Eighth

PA On/Off: ON PA Range: PA Range LNA Range: LNA Range CAGC_TX_CTL: CAGC_RX_AGC: LoadCAGC: LoadCAGC SAT: 5970 Hz 6030 Hz 6000 Hz Disable
TXPwRlimit: TX Mute: MUTE UNMUTE RX Mute: MUTE UNMUTE Compander: ON OFF

PDM: I Offset: 0 Close 255 128 255 128 255 128 255 128
0 Offset: 0 Close 255 128 255 128 255 128 255 128
1 x AGC: 0 Close 511 128 255 128 255 128 255 128
Rx AGC: 0 Close 255 128 255 128 255 128 255 128
TRK_LO: 0 Close 511 128 255 128 255 128 255 128
1 x Comp: 0 Close 255 128 255 128 255 128 255 128
Rx Comp: 0 Close 255 128 255 128 255 128 255 128

ADC: RF Detect: RF Detect: Get Get
Battery Voltage: Battery Voltage: Get Get
PA Temp: PA Temp: Get Get
Charge Current: Charge Current: Get Get
Battery Thermistor: Battery Thermistor: Get Get
Battery Feedback: Battery Feedback: Get Get
ADC 7: ADC 7: Get Get

TXWBD_PVC: RXWBD_PVC: SetAll: Set Ringer: ON OFF

Set NAFall: Index: Value: Set
Set NAOOffset: Index: Value: Set
Set NARise: Index: Value: Set
GetSynthLockState: Get

ESN: Get
IsOnline: Get
PhoneT: Get

SCRIPTS: New Script Save Script
Conversions: Conversions

RadioComm by Pries
Setup Buttons

Copyright Motorola, Inc. 2000-2002. All Rights Reserved

Comm Mode: RS232 - QC API COM Port: 1 BaudRate: 38400 PST: ???

Start
AMOR - Microsoft Internet...
Microsoft PowerPoint - R...
RadioComm (Service ...

1:26 PM

Enter Channel number and Click on "Set Chan"

800 CDMA RX TEST SETUP

RadioComm (Service Edition) v3.5.1 CDMA 1X

Main Settings Phone Help

Init Mode Mode
 Init COM Port CDMA 800
 Diag Mode CDMA 1800
 CDMA 1900
 AMPS
 GPS SIMAD

Channel
 350
 Set Chan

Rx: 880.5
 Tx: 835.5

Sent To Radio: SetM_RXMute(0)
 Returned From Radio: 1

Single
 SW Version
 Get

SCRIPTS
 New Script
 Save Script
 Conversions
 Conversions



RX Test

Click on RX "UNMUTE"

Phone RAM Download
 <No File Selected>
 Browse Flash Done

TX On/Off
 ON
 OFF

TX Wavelom
 CDMA
 CW

Data Rate
 Full
 Quarter
 Half
 Eighth

TXPW/RLimit
 Set

Audio Path
 External
 Internal
 Boom

TX Mute
 MUTE
 UNMUTE

RX Mute
 MUTE
 UNMUTE

Compaander
 ON
 OFF

TX ST
 ON
 OFF

PA On/Off
 ON
 OFF

PA Range
 PA Range
 Set

LNA Range
 LNA Range
 Set

CAAGC_TX_CTL
 CAAGC_TX_CTL
 Get

CAAGC_RX_AGC
 CAAGC_RX_AGC
 Get

LoadCAAGC
 LoadCAAGC
 Get

SAT
 5970 Hz
 6030 Hz
 6000 Hz
 Disable

GetRSSI
 GetRSSI
 Get

TXRX_VOICE
 ON
 OFF

TX ST
 ON
 OFF

Blank

Blank

PDM I Offset
 0
 Close

Q Offset
 0
 Close

Tx AGC
 0
 Close

Rx AGC
 0
 Close

TRK_LD
 0
 Close

T x Comp
 0
 Close

Rx Comp
 0
 Close

TXWBD_PVC
 ON
 OFF

RXWBD_PVC
 ON
 OFF

SellNAOffset
 Index
 Value

SellNAOffset
 Index
 Value

Blank

255
 128
 Set

255
 128
 Set

511
 256
 Set

255
 128
 Set

511
 256
 Set

255
 128
 Set

255
 128
 Set

Get ALL

Set NAOffset
 Index
 Value

Set NAOffset
 Index
 Value

Blank

Blank

Get
 Poll ON
 Poll OFF

Get
 Poll ON
 Poll OFF

Get
 Poll ON
 Poll OFF

Get
 Poll ON
 Poll OFF

Get
 Poll ON
 Poll OFF

Get
 Poll ON
 Poll OFF

Get ALL

Set Finger
 ON
 OFF

GetSynthLockState
 Get

Blank

Blank

Blank

128
 Poll ON
 Poll OFF

128
 Poll ON
 Poll OFF

256
 Poll ON
 Poll OFF

128
 Poll ON
 Poll OFF

256
 Poll ON
 Poll OFF

128
 Poll ON
 Poll OFF

Get ALL

Set Finger
 ON
 OFF

GetSynthLockState
 Get

Blank

Blank

Blank

128
 Poll ON
 Poll OFF

128
 Poll ON
 Poll OFF

256
 Poll ON
 Poll OFF

128
 Poll ON
 Poll OFF

256
 Poll ON
 Poll OFF

128
 Poll ON
 Poll OFF

Get ALL

Set Finger
 ON
 OFF

GetSynthLockState
 Get

Blank

Blank

Blank

Troubleshooting

Introduction

Known good replacement parts and assemblies should be available to be used for troubleshooting by substitution, and for replacement of defective parts/assemblies. Defective circuit boards should be forwarded to the appropriate Motorola service facility for repair. Refer to the “Replacement Parts” section of this manual for a list of replacement part descriptions and part numbers.

CAUTION

Many of the integrated circuit devices used in this equipment are vulnerable to damage from static charges. An ESD-safe workstation should be used whenever a transceiver is opened.

Troubleshooting and Repair

Refer to the disassembly instructions located in the “Disassembly” section of this manual for instructions on removing parts/assemblies.

Testing after Repair

After any repair work has been carried out, the unit should be thoroughly tested to ensure that it operates correctly. This is especially important if the Logic / RF assembly is replaced.

For general repairs which do not include replacing the Logic/RF assembly, simply placing a call and checking signal strength, and transmit and receive audio quality is normally sufficient.

When the Logic/RF assembly is replaced, the unit must have a comprehensive test on a CDMA cellular/PCS compatible communications analyzers. See “Testing” for further details. Placing a call on air is usually carried out at this stage to complete the testing procedure.

(Note: The field test guide will also provide you with additional information and help you in investigating a problem.

TROUBLESHOOTING

The goal in trouble shooting is to quickly narrow down the possibilities to isolate a failure to a single faulty component. This is especially important before deciding to replace a large IC, filter or any component that is difficult or risky to replace. Sometimes the problem will be visually obvious. For example: a cold solder joint, cracked chip, tombstone parts etc., other times it will be necessary to take some measurements.

NO TURN ON – DEBUG PROCEDURE

- Visual check – look for any damaged parts, unsolder, Cold solder or missing parts
- Checking for short circuits – apply 4.4V power supply with a 1A current limit through the external connector. If the phone draws more than 0.5A, check all the regulators signals for short to ground
- Check for the power B+ at C3803 or C3804, if no B+ present replace U3800
- Place a zero ohm resistor at R3000
- Check the regulated output voltages
- if the voltages on the regulators are not correct

Table 7:

Linear Regulator	Nominal Voltage	Location to check
VREG_MSMP	2.83V	C3200
VREG_MSMC	2.86V	C3150
VREG_MSMA	2.65V	C3100
VREG_IF	2.90V	C3250
VREG_TCXO	2.75V	C3450

reflow or replace U3000

- Check the RTC clock Y3000: check the clock for 32.768 Khz signal if not present check C3000, C3001, C3002 and C3011, then replace Y3000
- Check the 19.2 Mhz clock signal at C3012 if

not present check L650 and replace Y650

Remember to remove R3000 – zero ohm resistor after the trouble shooting process.

Internal Charger Test Debugging

Phone must be in Phone T mode to analyze charger.

In DMSS mode, the default state of the charger is off unless a valid charger (fast or mid rate) and battery (EPROM and Thermistor present) are detected by software.

Charging circuitry (except for PM1000) is next to battery contact block and not under any shields.

When charger is disabled, the EXT_B+ current should be ~150mA +/- 50mA. Otherwise battery charge test current limits will be exceeded. This failure may not be caused by the charger circuit.

When charger is enabled (using set DVT Option command) with 3.6V battery connected, EXT_B+ current should be at 1A for high current test, and ~370 for mid rate current test. If not, verify that EXT_B+ is >4.4V at CEBUS connector and battery voltage is 3.6V at the battery contact block.

When charger is enabled, battery charge current will be 1A – EXT_B+_Current for high rate, and 370mA – EXT_B+_Current for mid rate current settings.

When charger is enabled, voltage on R3800 (side connected to U3800) should be at 1.5V. This voltage is proportional to the EXT_B+ current and is calculated by $(EXT_B_CURRENT / CURRENT_LIMIT) * 1.5$ where current limit is either 1A or 0.370A.

RECEIVER TROUBLESHOOTING

- No Service
 - Make sure phone has service programming and has phasing data stored. This can be verified by QPST.
 - Check for Rx IF VCO (367.2MHz) to be on frequency. Measure Rx IF VCO control voltage. It should be between 1 and 2 volts.
 - Check for RF signals after each of the filters, and major functional blocks.
 - Check for RF at Antenna -> Diplexor -> Duplexor -> LNA -> RF Interstage Filter -> Mixer -> PA.
 - Check LO frequency is locked and is present at the input of the mixer (RFR3300).
 - Check supplies to each functional block. Receiver runs off 2.75V.

TRANSMITTER TROUBLESHOOTING

Check for I and Q going into RFT3100.

Check for LO input into RFT3100. Level should be about -15dBm.

Check for Tx IF VCO Frequency and control voltage.

Tx IF VCO frequency is 457.2MHz for 800MHz CDMA and AMPS, and 527.2MHz for PCS CDMA.

Control voltage at 457.2MHz is about 1volt, and 2volts at 527.2MHz.

Check for Tx IF (near the Tx IF Filter)
Tx IF is 228.6MHz for 800 MHz CDMA & AMPS

Tx IF is 263.6MHz for 1900 MHz CDMA
Check for Tx RF at RF filter input and at PA input.

Symptom	Probable Cause	Verification and Remedy
1. Phone will not turn on or stay on.	a) Battery either discharged or defective.	<ol style="list-style-type: none"> 1. Measure battery voltage across a 50 ohm (>1 Watt) load. 2. If the battery voltage is <3.4 V DC, recharge the battery using the appropriate battery charger. 3. If the battery will not recharge, replace the battery.
	b) Battery connector open or misaligned.	<ol style="list-style-type: none"> 1. Visually inspect the battery connectors on both the battery pack and the transceiver, including the solder connections from the battery connector to the main PC board. 2. Realign the contacts or, if necessary, replace either the battery or battery connector.
	c) Transceiver Board defective.	<ol style="list-style-type: none"> 1. Replace the keypad membrane with a known good part. 2. Temporarily connect 4.5 V DC to the battery contacts. 3. Depress the PWR button; if unit turns on and stays on, disconnect the power source and reassemble the phone with the new keypad membrane.
	d) Transceiver Board Debugging Follow the no turn on Debug procedure.	<ol style="list-style-type: none"> 1. Remove the Transceiver Board. Substitute a known good board. 2. Temporarily connect 4.5 V DC to the battery contacts. 3. Depress the PWR button; if unit turns on and stays on, disconnect the power source and reassemble the phone with the new RF/Audio-Logic board and re-test phone.
2. Phone exhibits poor reception and/or erratic operation (such as calls frequently dropping, weak and/or distorted audio, etc.)	a) Defective antenna or damaged antenna connector.	<ol style="list-style-type: none"> 1. Replace the antenna with a known good antenna.
	b) Defective RF/ Audio-Logic Board.	<ol style="list-style-type: none"> 2. Check for loose or damaged cans.

Symptom	Probable Cause	Verification and Remedy
3. Display is erratic, or provides partial or nodisplay.	a) Defective display module. b) RF/Audio-Logic board defective.	1. Disassemble the display and reassemble to check the connection. If it does not recover, check the transceiver board. 2. Check connection. If connection not at fault, proceed to b. Replace the RF/Audio-Logic Board
4. Alert ringer volume is distorted or too low.	a) Alert defective. b) RF/Audio-Logic board defective.	1. Replace the defective alert with a known good alert. 2. Replace the RF/Audio-Logic Board
5. Transmit audio is weak, distorted, or dead.	a) Microphone defective. b) RF/Audio-Logic board defective.	1. Replace defective microphone. 2. Replace the RF/Audio-Logic Board
6. Receive audio is weak and/or distorted.	a) Speaker defective. b) RF/Audio-Logic board defective.	1. Replace defective speaker. 2. Replace the RF/Audio-Logic Board

This page is intentionally left blank.

Antenna Circuit: A3

V120 E

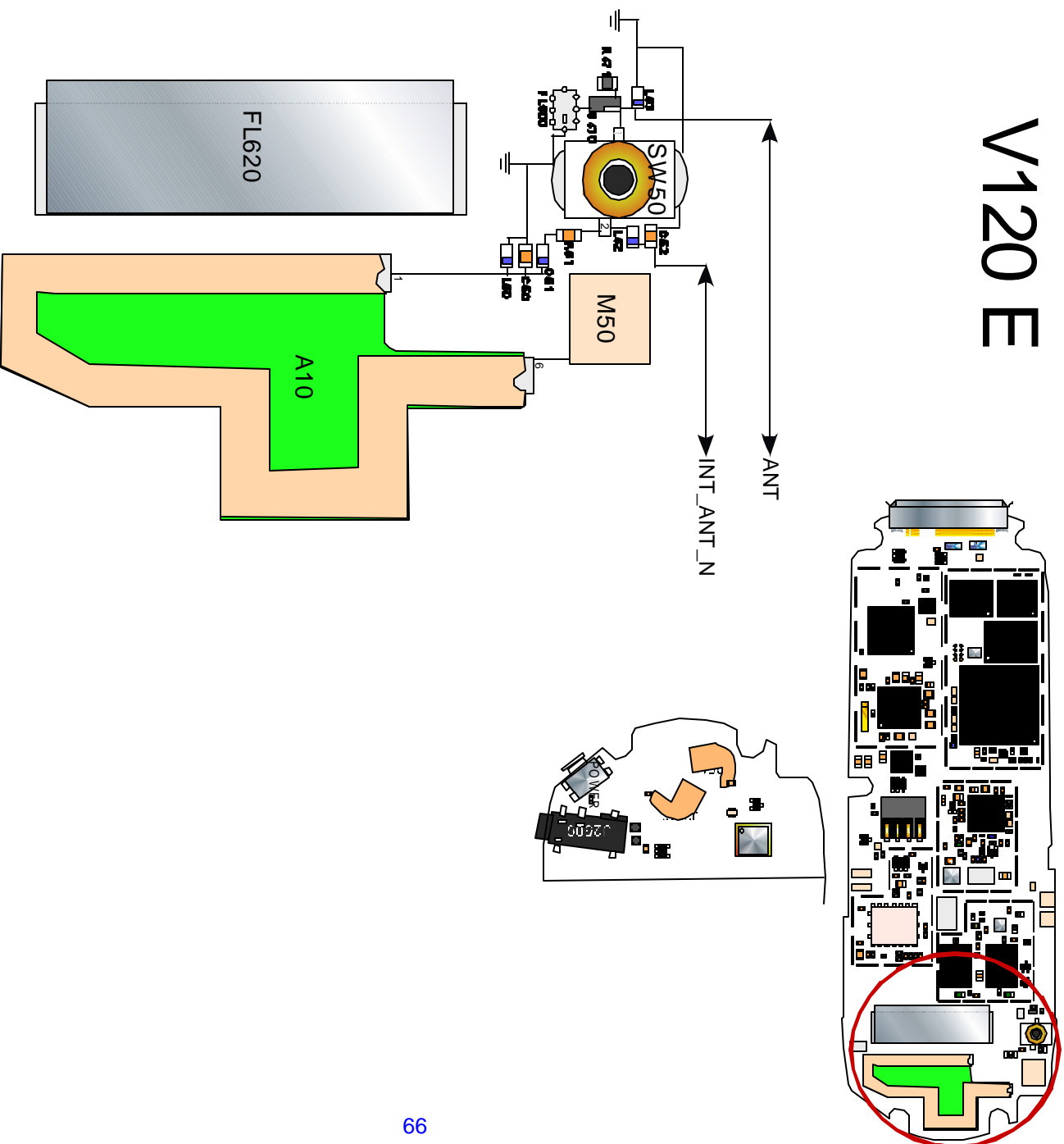

This document is property of MOTOROLA and it should be return if not used. Distribution and copies of this document are not allowed with out MOTOROLA approval.

MOTOROLA CONFIDENTIAL PROPRIETARY
BOARD - L07

RECEIVER SECTION

The receiver section occupies a frequency band of 869 Mhz to 894 Mhz in cellular band and a frequency band of 1930Mhz to 1990Mhz in PCS band. Rf signal received from the antenna is applied to duplexer and then through duplexer to RFR3300. Inside the RFR3300 the first step is it goes through LNA, where it is amplified and then applied to BPF. Finally only necessary signals are sent to the down converter – the first mixer. At this time the down converter (first mixer) mixes the RF signal with Local Oscillator signal generated by the Dual band VCO/PLL module. The IF 183.6 Mhz in frequency (same for both the Cellular and PCS band) is derived from the mixing operation is applied to the IF band pass filter and only necessary signals are selected. The IF signal now enters the IFR IC.

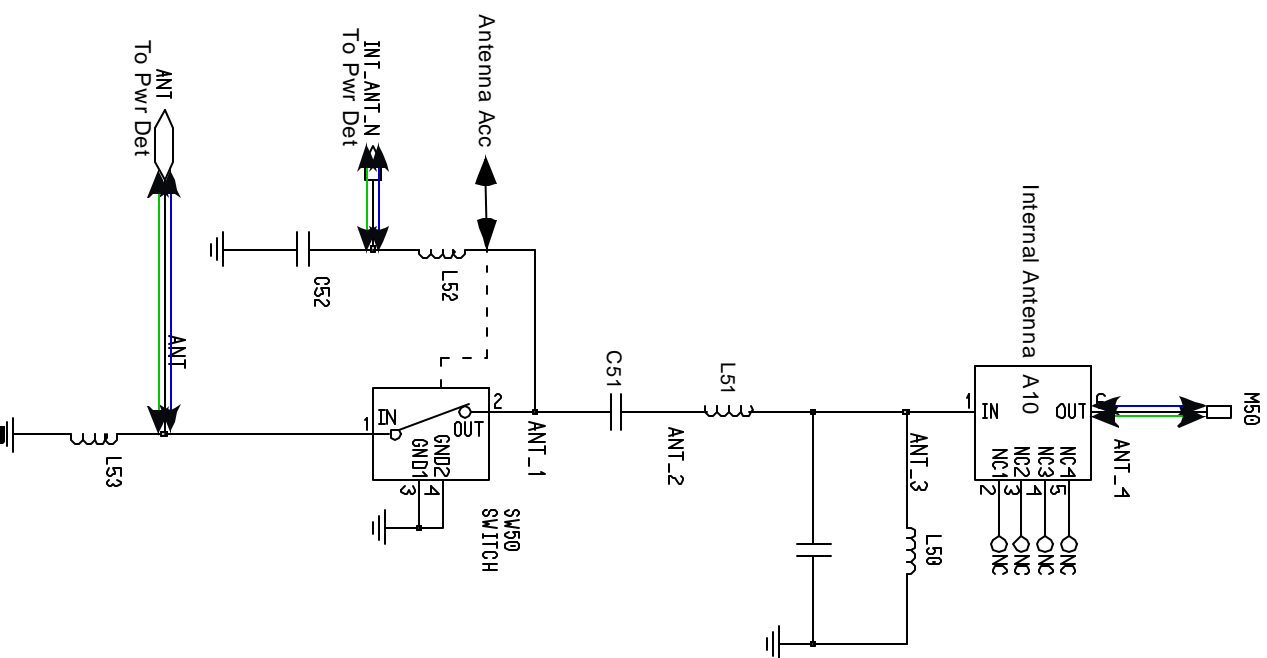

Duplexer Circuit: A3c

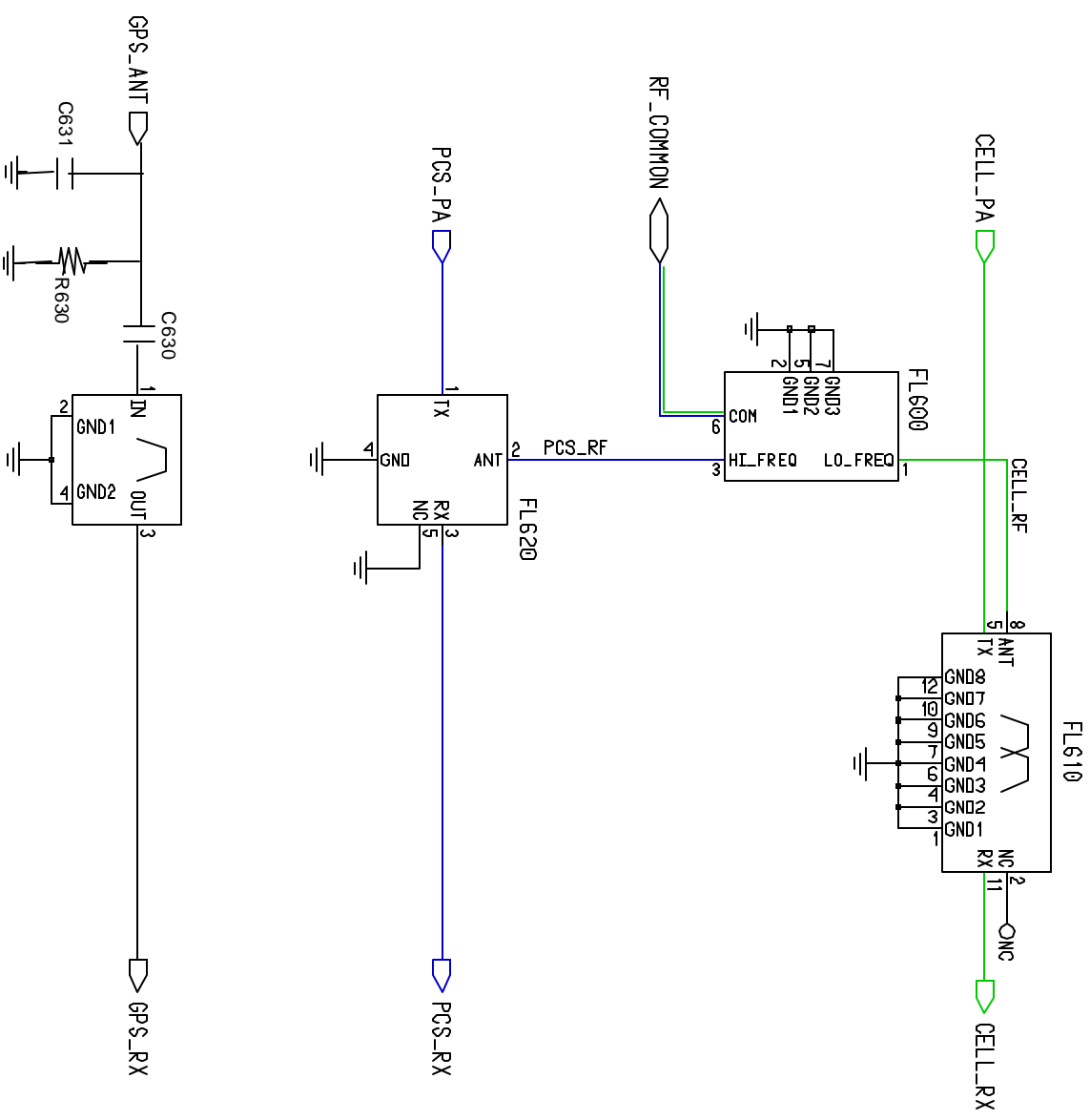

This document is property of MOTOROLA and it should be return if not used. Distribution and copies of this document are not allowed with out MOTOROLA approval.

AGPS Antenna: A03d

V120E AGPS

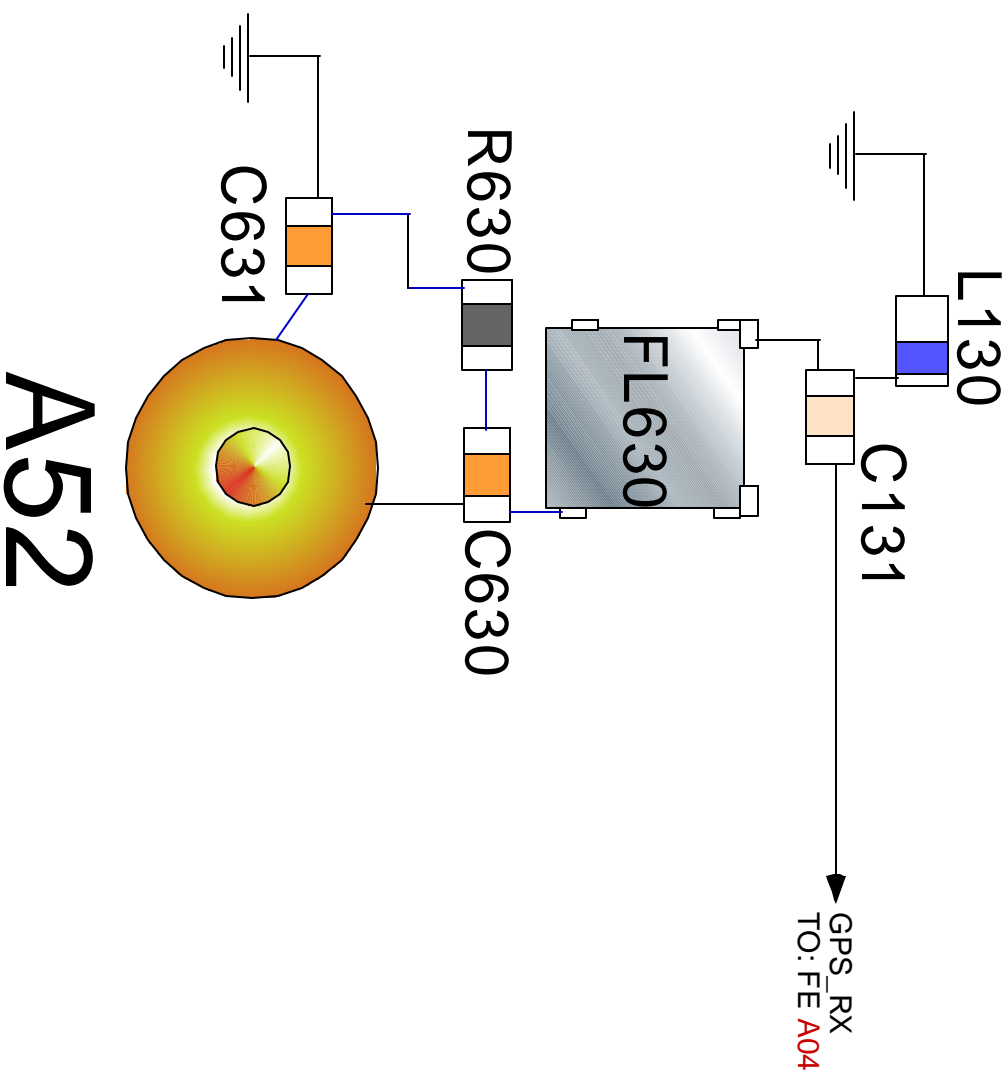
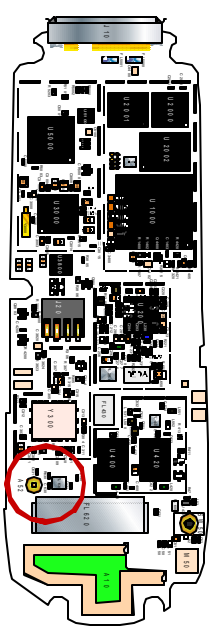

This document is property of MOTOROLA and it should be return if not used.
Distribution and copies of this document are not allowed with out MOTOROLA approval.

MOTOROLA CONFIDENTIAL PROPRIETARY

BOARD - L07

FE Circuit: A4b

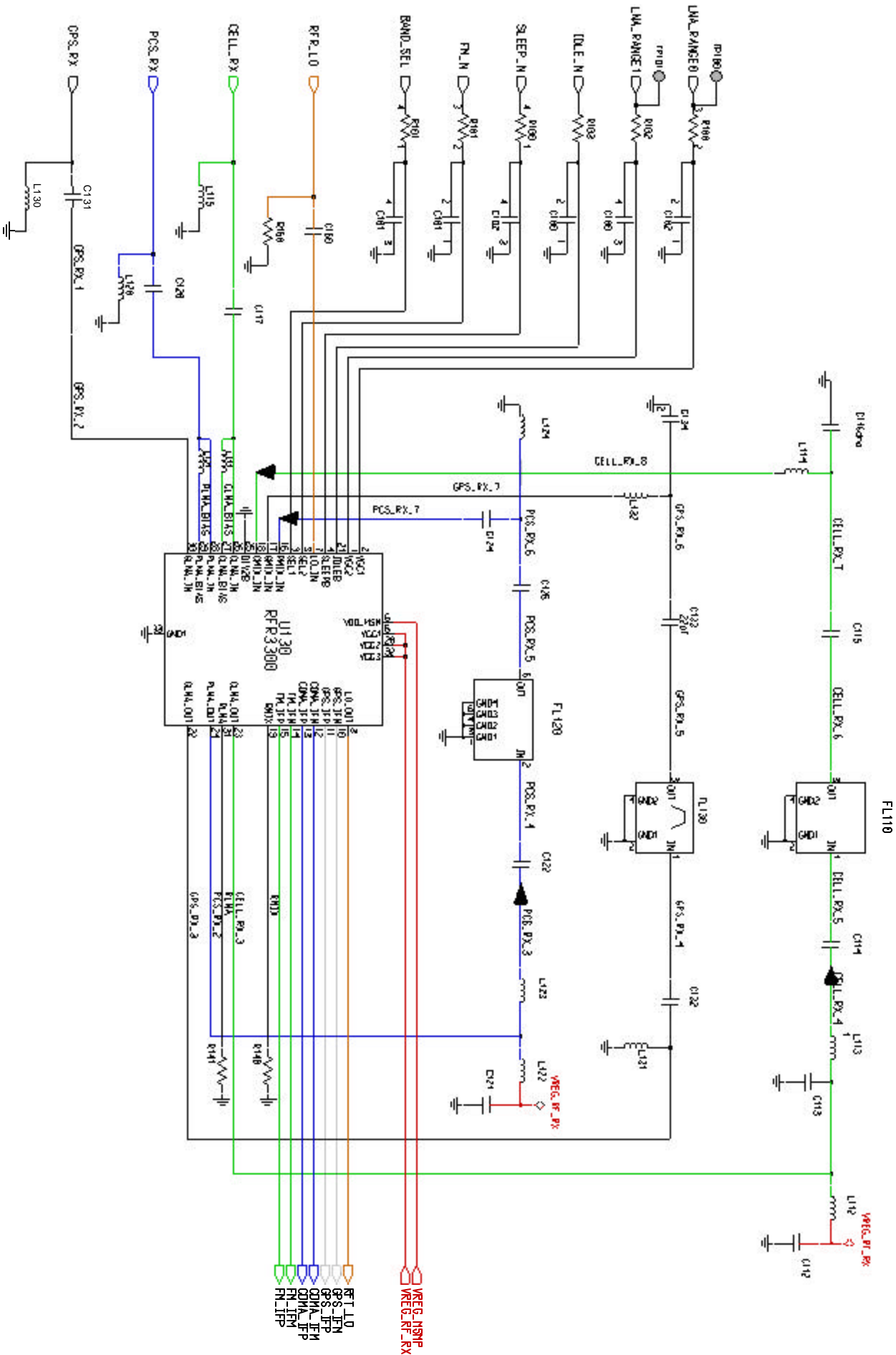

V120 E

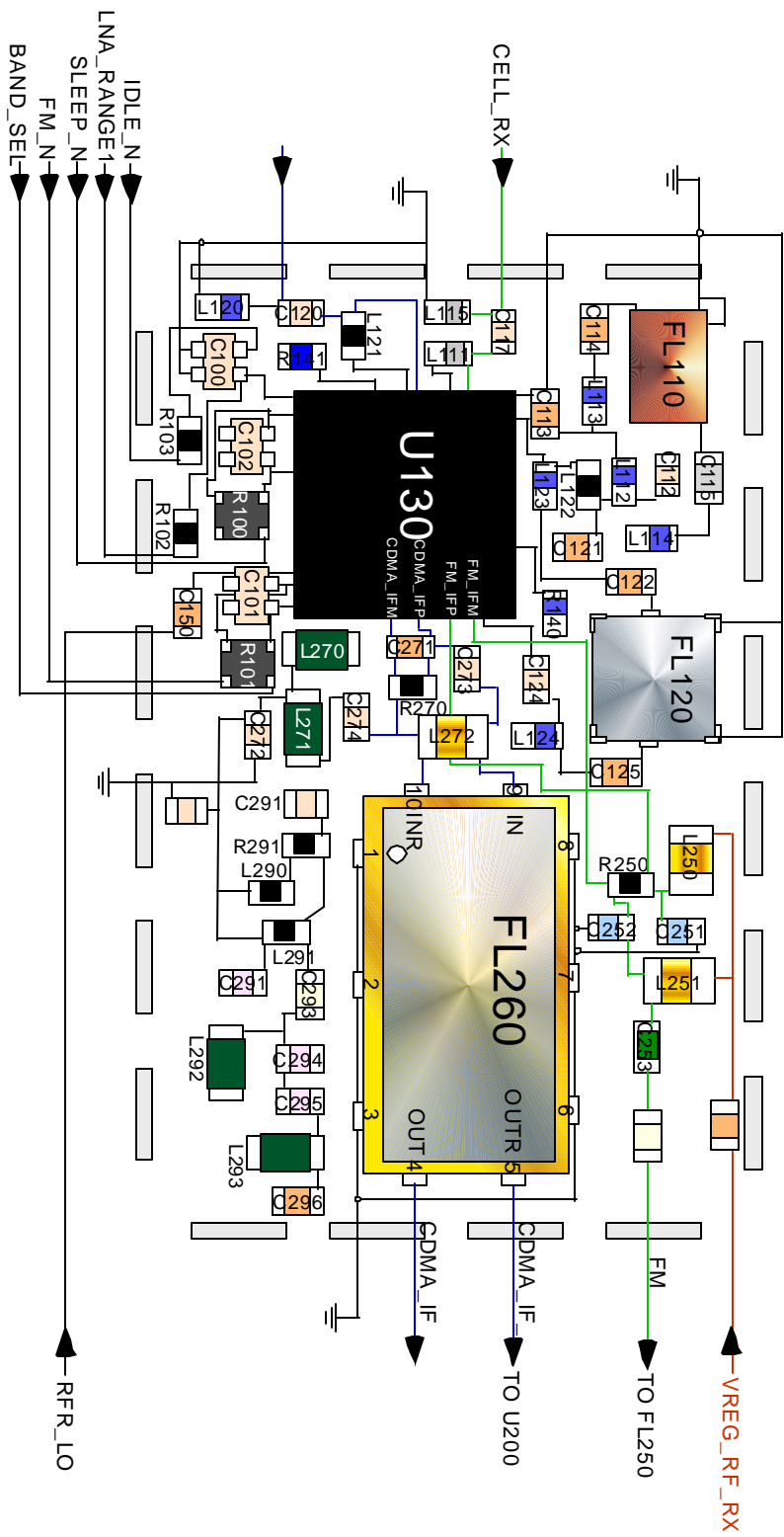
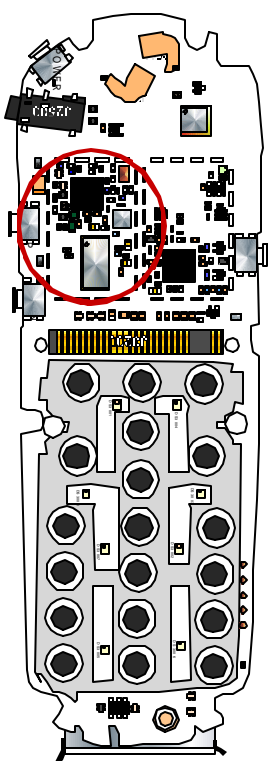

This document is property of MOTOROLA and it should be return if not used. Distribution and copies of this document are not allowed with out MOTOROLA approval.

MOTOROLA CONFIDENTIAL PROPRIETARY

BOARD - L07

IF Circuit : A04c

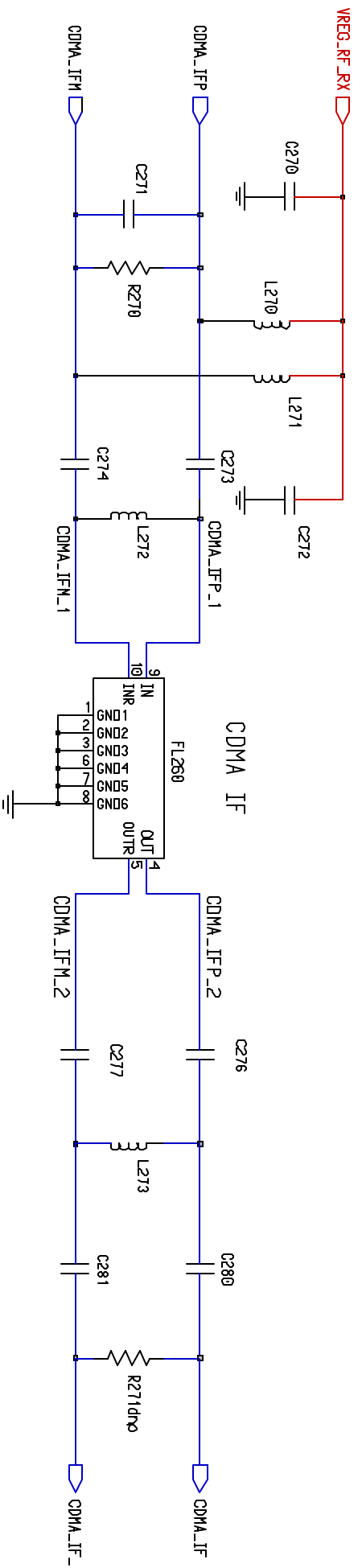

IF CELL / REF OSC:A5

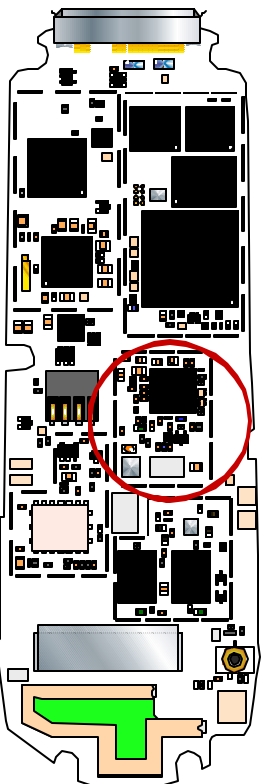
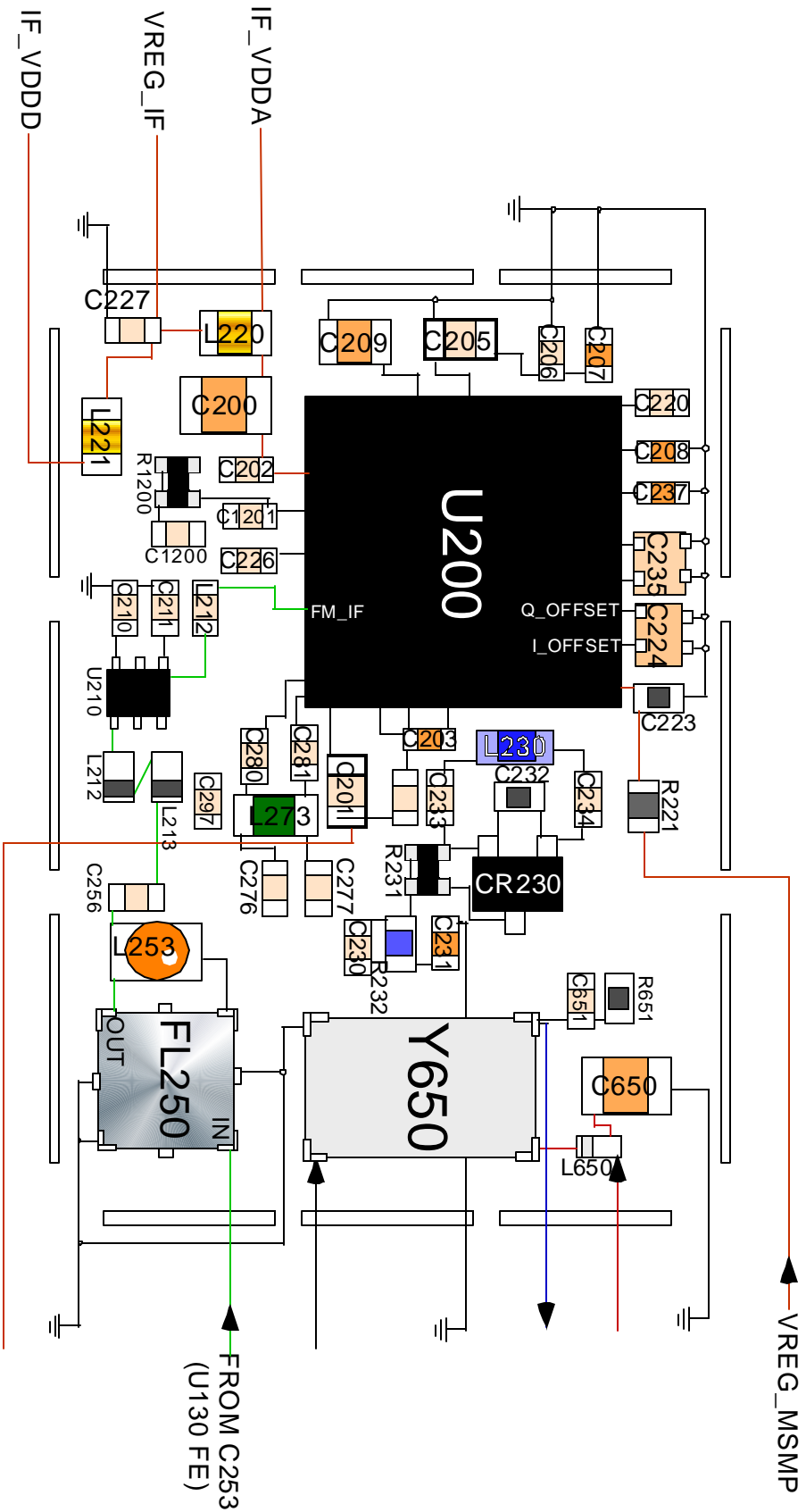

IFFILT Circuit : A05c

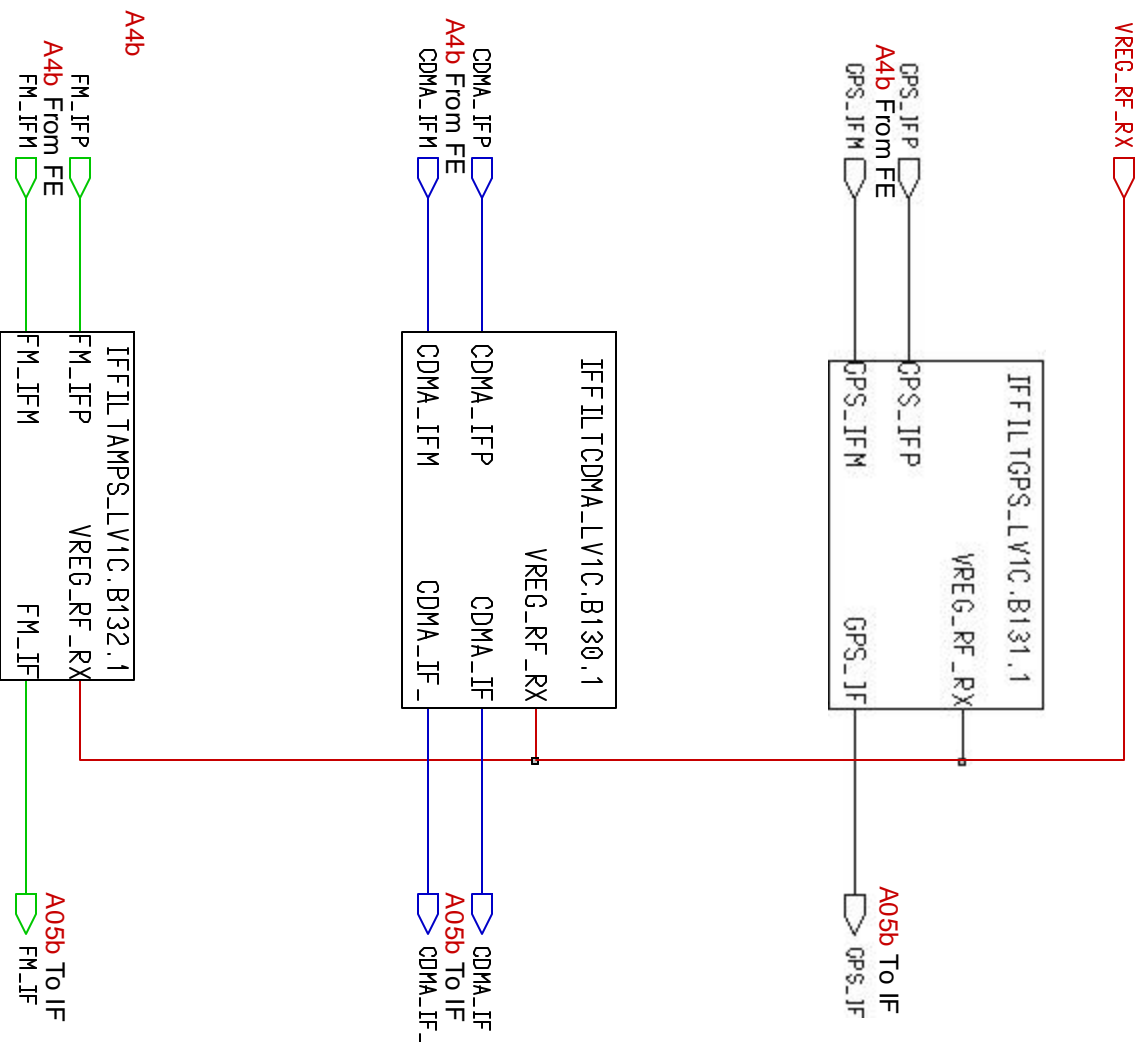

First it is induced to AGC Amp inside the IFR3000/IFR3300 which is adjusted to PDM (pulse density modulation) signal by received signal strength level (RSSI). This AGC amplifier is adjusted to the size matching to the input sensitivity of IFR(analog baseband). The AGC dynamic range is approximately 90 dB.

The output of AGC is down converted at 2nd mixer in order to obtain a baseband signal necessary for demodulation. For this purpose the 2nd Local oscillator, VCO of 367.2 Mhz signal is produced which is divided in frequency by half to get 183.6Mhz second LO.

The Second IF signal is divided into I and Q signals within the baseband(Zero-IF) and then filtered through low pass filter and then get A/D conversion. This is then output from

Circuit : A05d

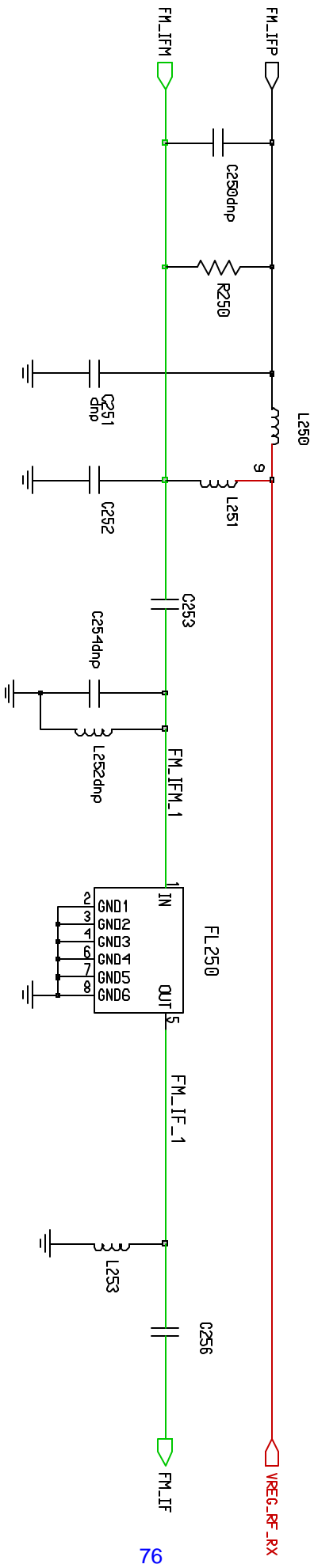

Ref Osc Circuit : A05e

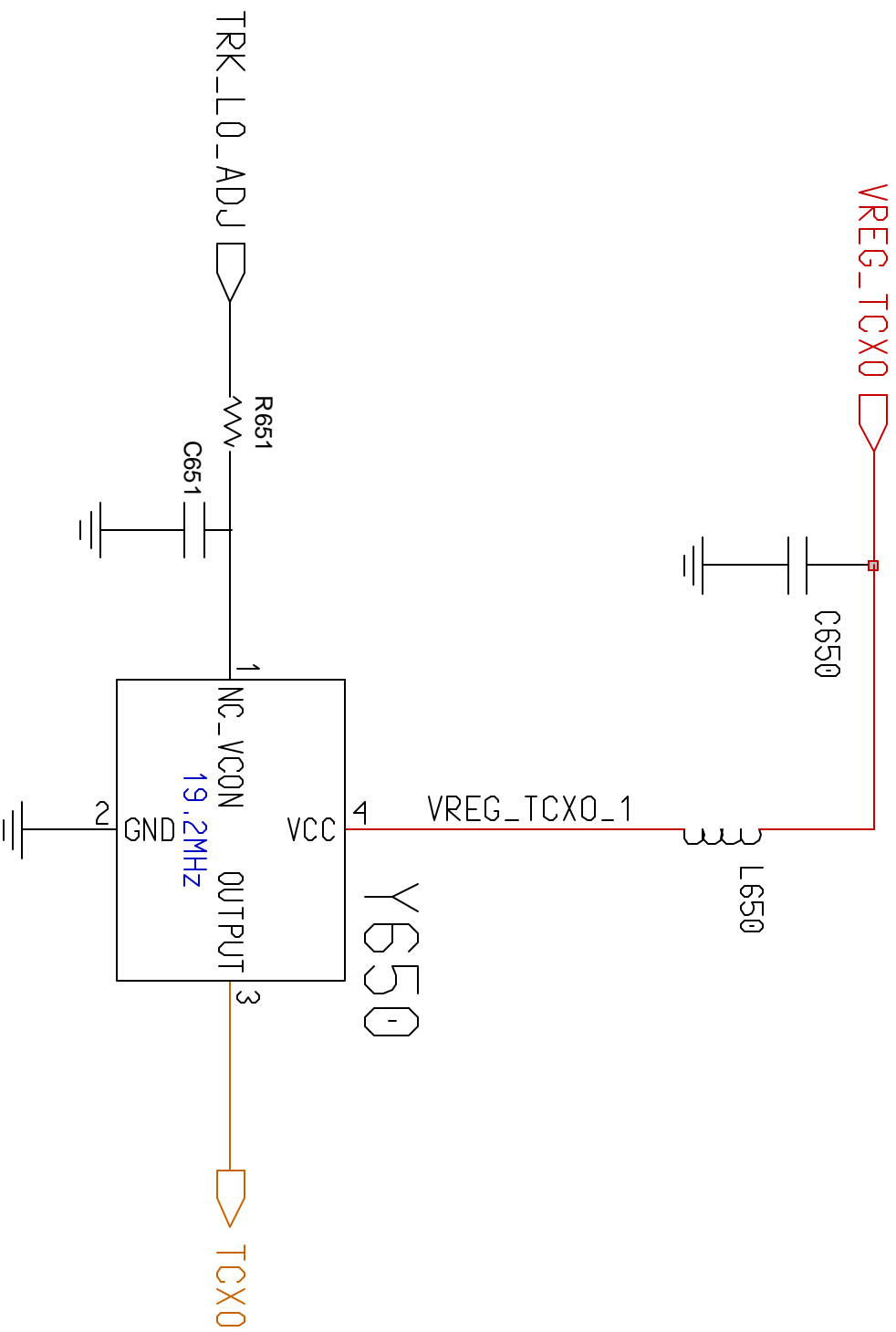

IFFILT CDMA Circuit : A05f

V120 E

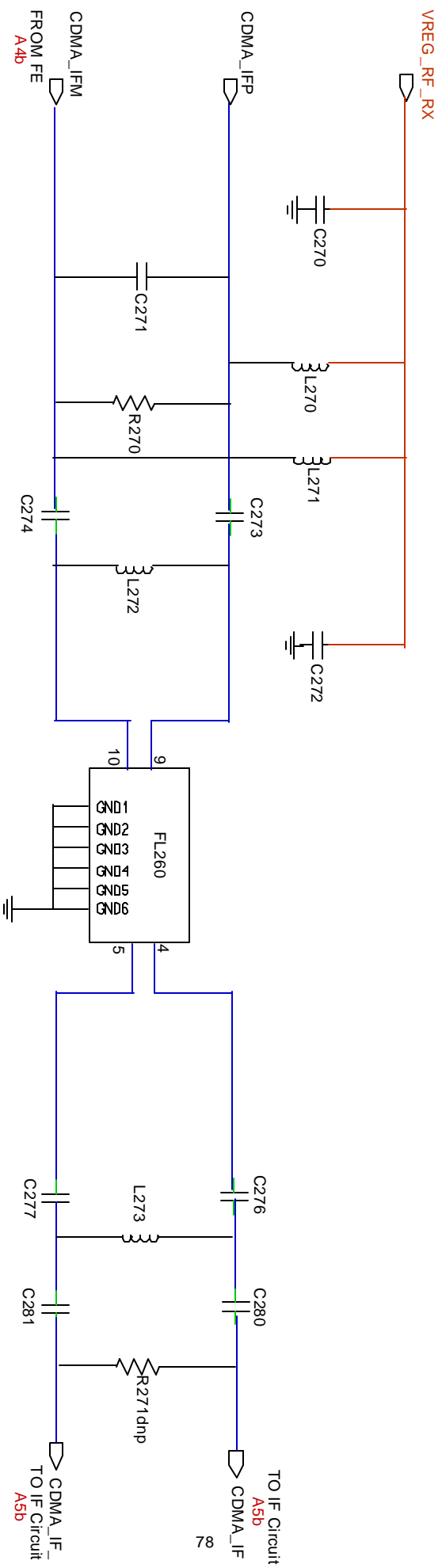

This document is property of MOTOROLA and it should be return if not used. Distribution and copies of this document are not allowed with out MOTOROLA approval.

MOTOROLA CONFIDENTIAL PROPRIETARY

BOARD - L07

IFFILT GPS Circuit : A05g

V120 E

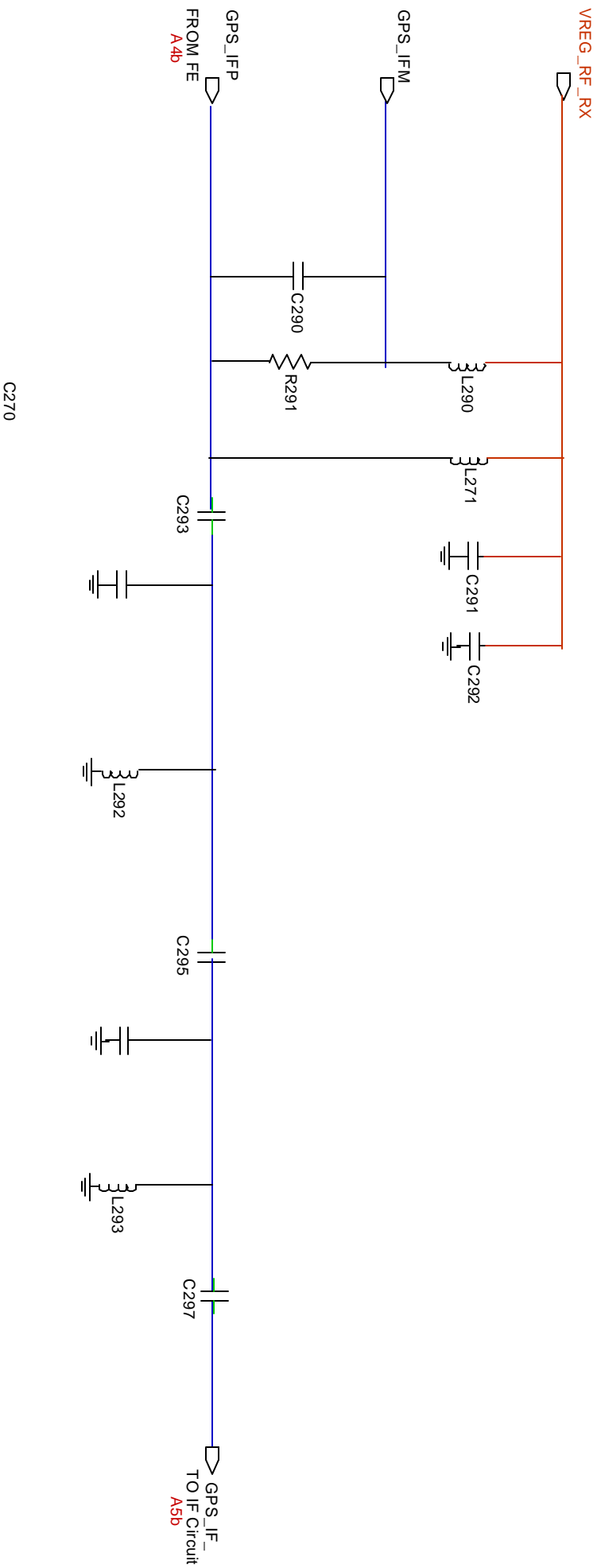

This document is property of MOTOROLA and it should be return if not used. Distribution and copies of this document are not allowed with out MOTOROLA approval.

MOTOROLA CONFIDENTIAL PROPRIETARY

BOARD - L07

PWR DET / TXUPMIX:A06C

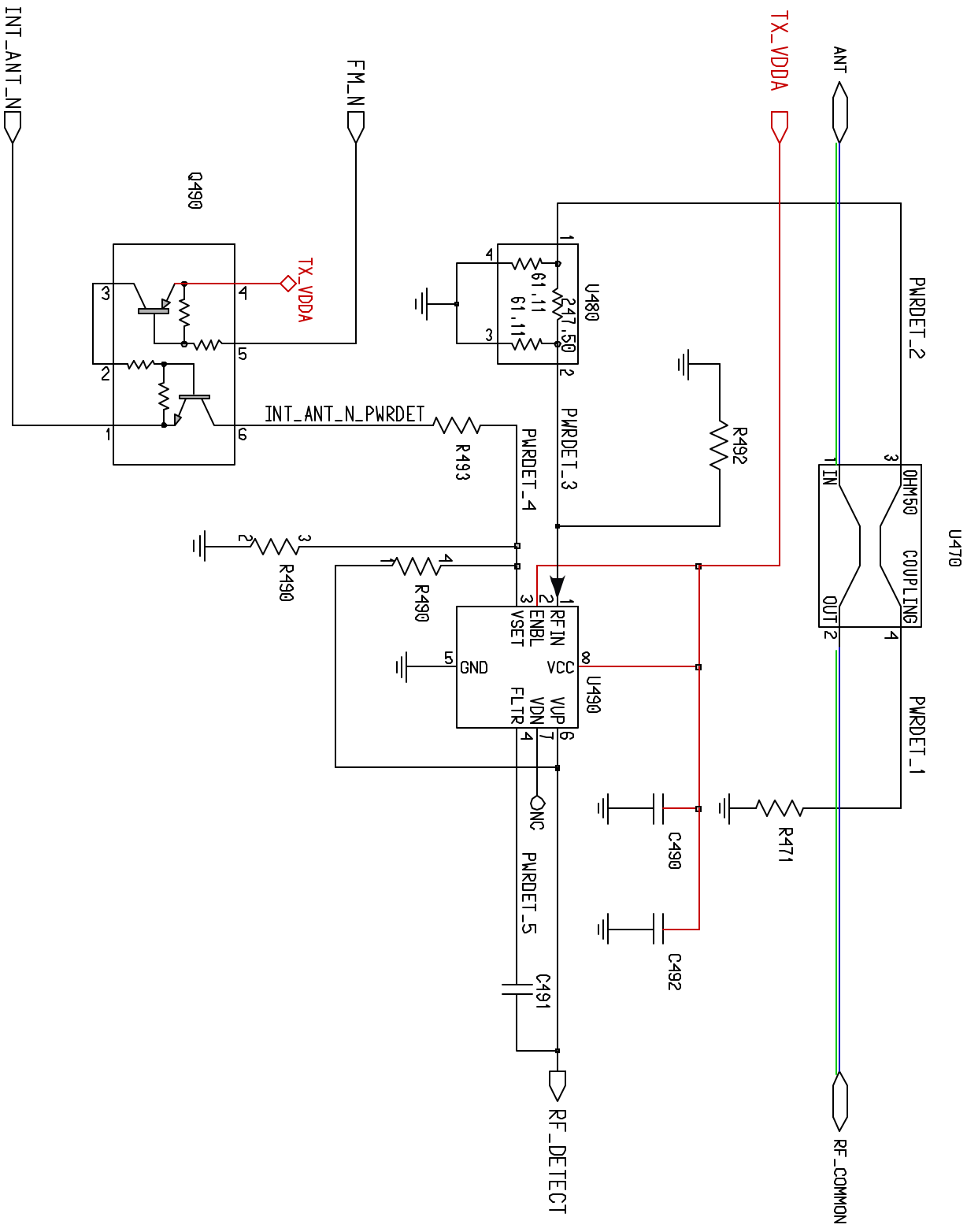

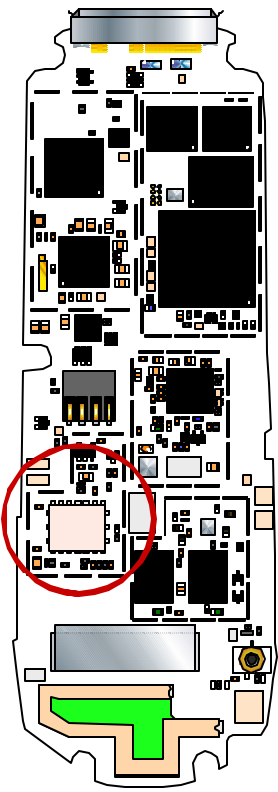
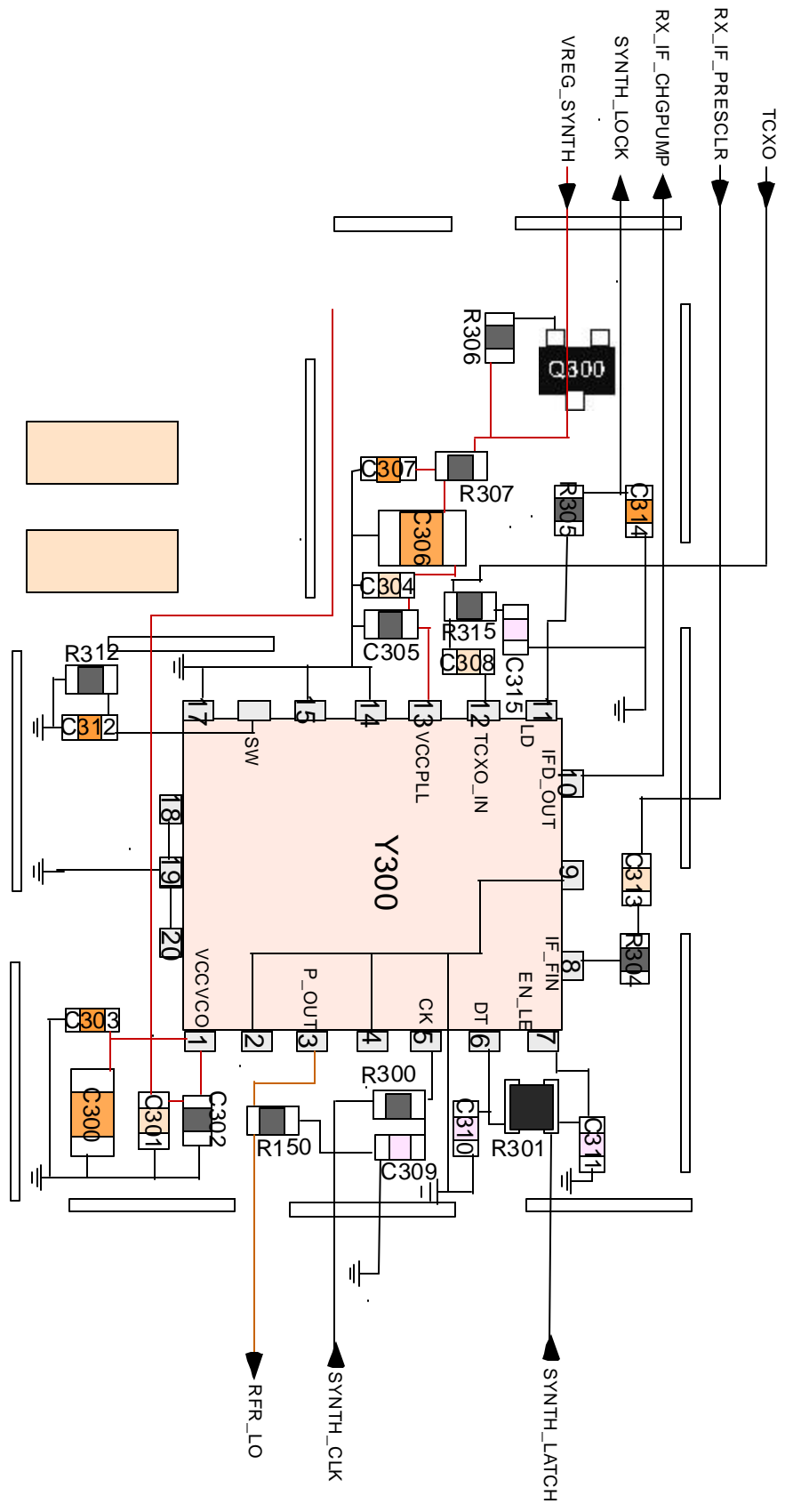

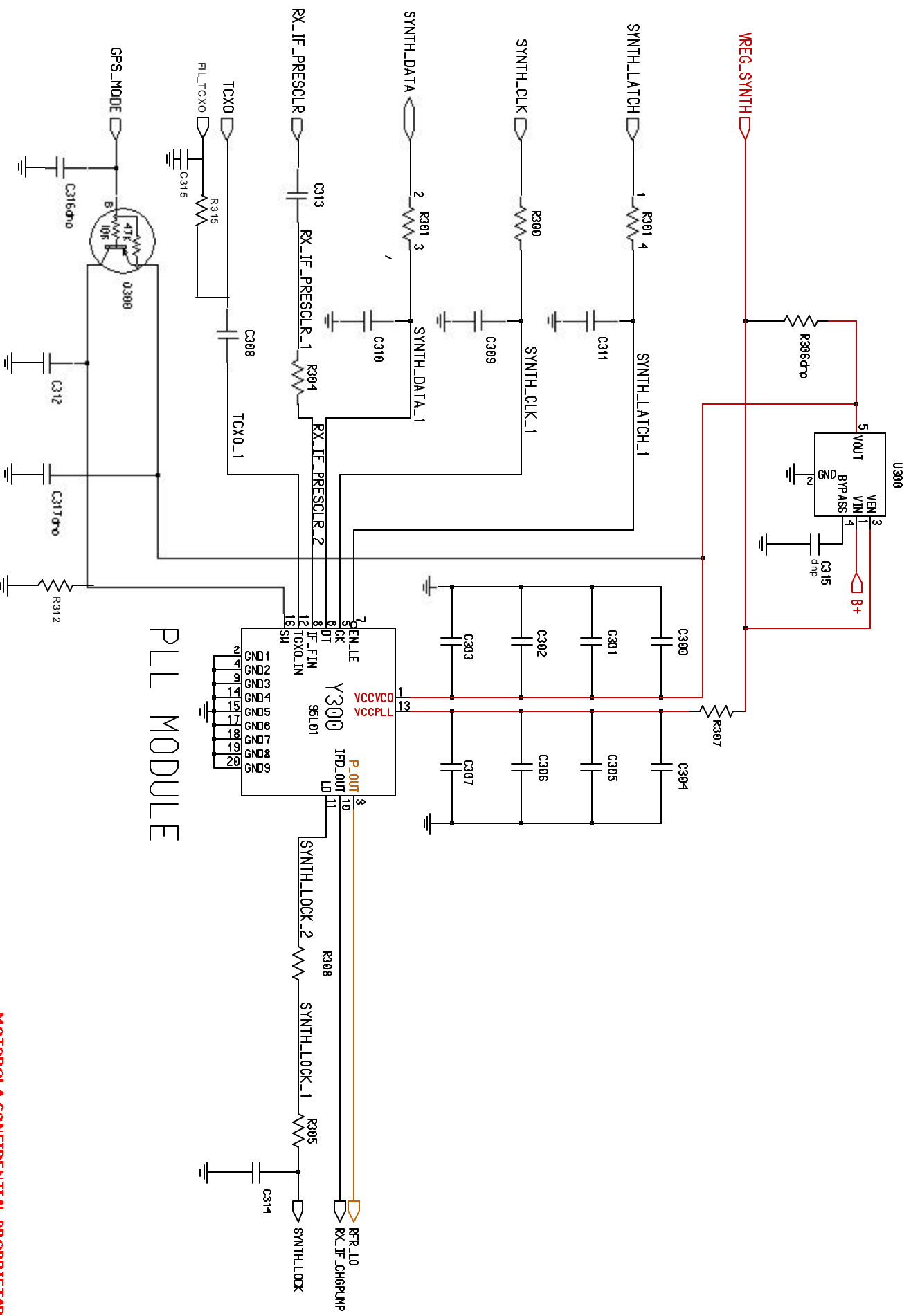

PLL MODULE

FREQUENCY SYNTHESIZER SECTION

The frequency synthesizer uses VC-TCXO-19.2Mhz as reference frequency. 19.2 Mhz is input to the frequency synthesizer as reference input of VCO/PLL MODULE IC and then divided to frequency appropriate for the channel spacing by the reference divider in the IC.

This IC generates LO signal for the conversion of Transmit/Receive carrier frequency. One is used LO signal to down convert at the 1st mixer in the receiver and the other is used as local signal for transmitter up converting mixer. Inside the IC the prescaler and the variable divider divides the input frequency(feed back) according to the channel number and frequency and then the phase detector compares it with the reference frequency and any correction is communicated through the LPF to the VCO.

The digital data for the determination of channels for the frequency synthesizer is sent from the MSM and consists of SYNTH_CLK, SYNTH_DATA, and SYNTH_LATCH in serial interface.

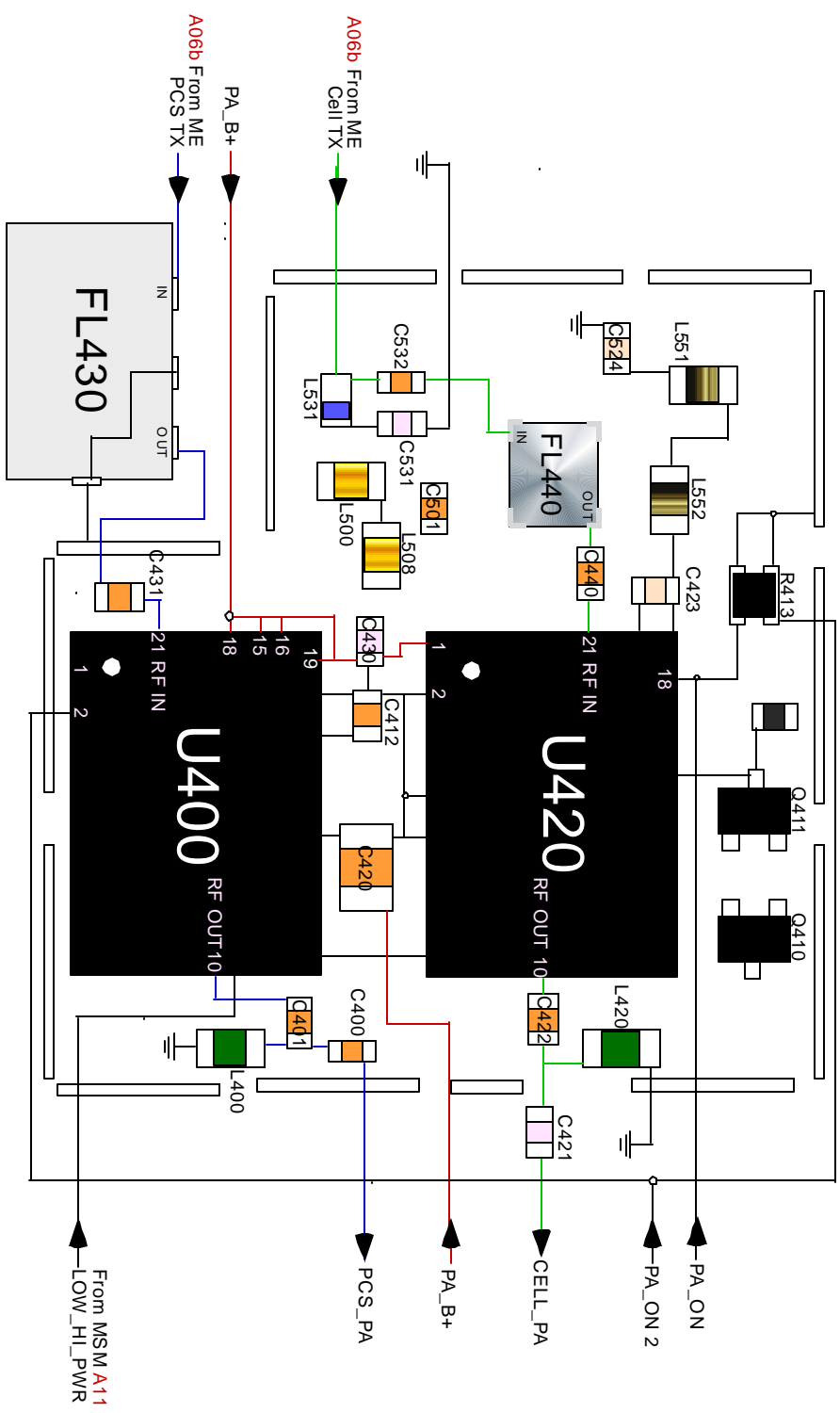
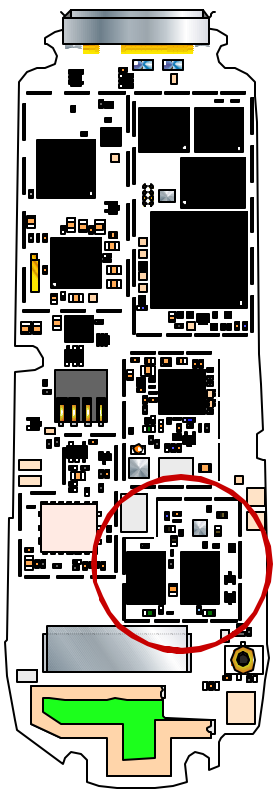

TX:A08b

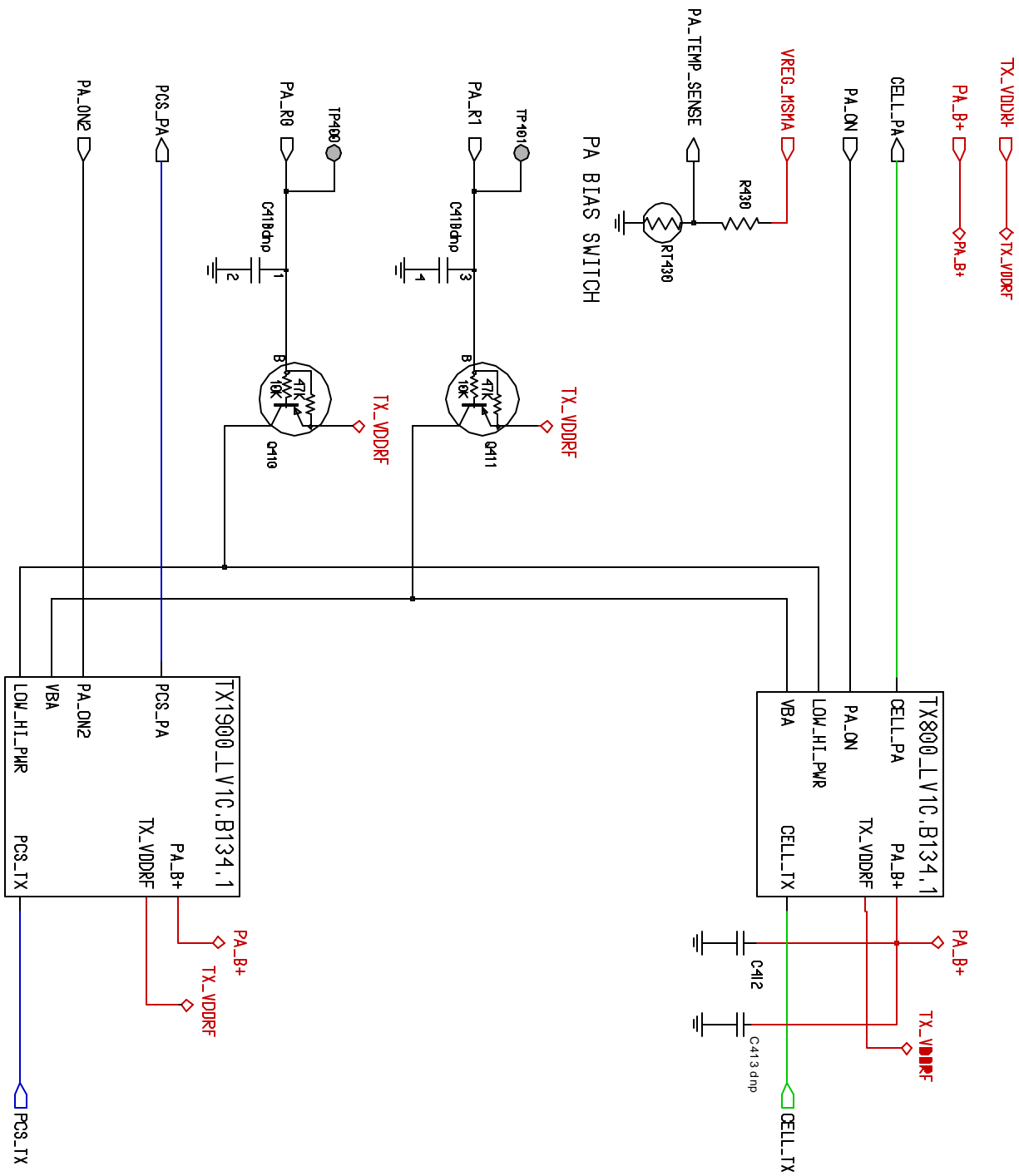

TX1900:A08C

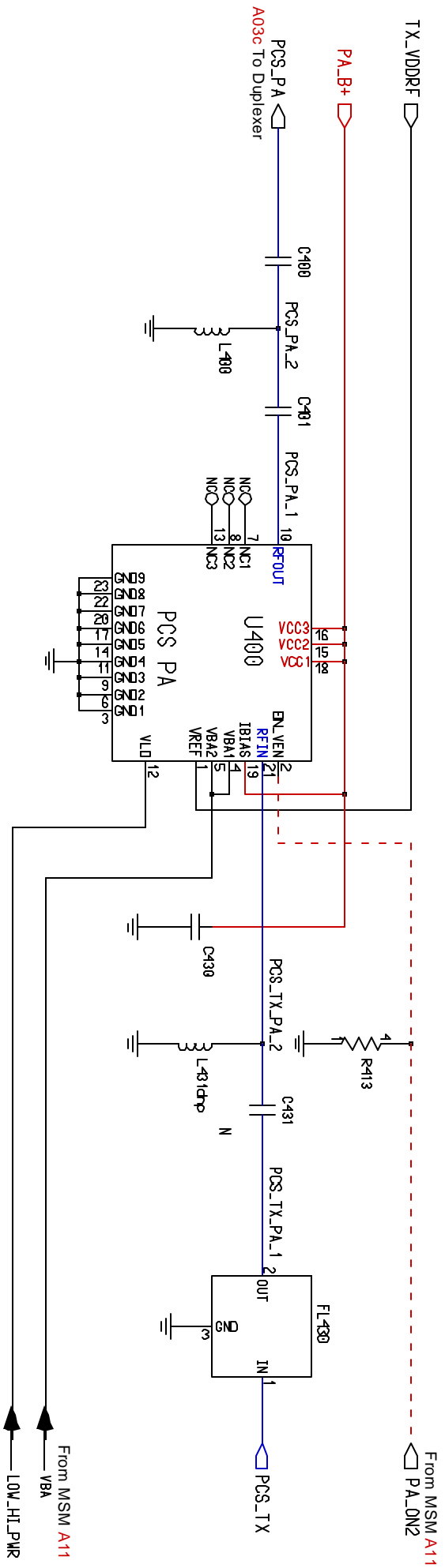

Connectors: A9

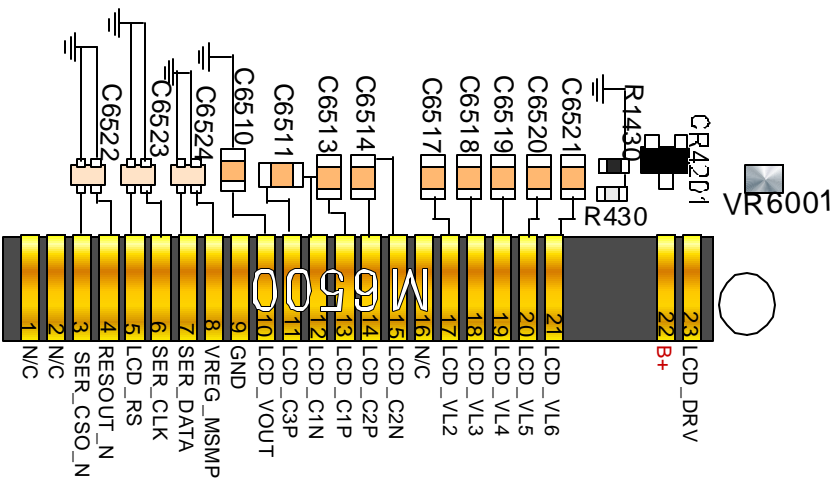

V120 E

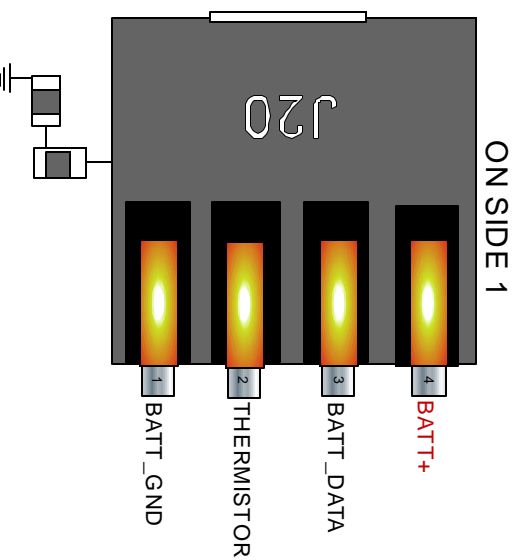
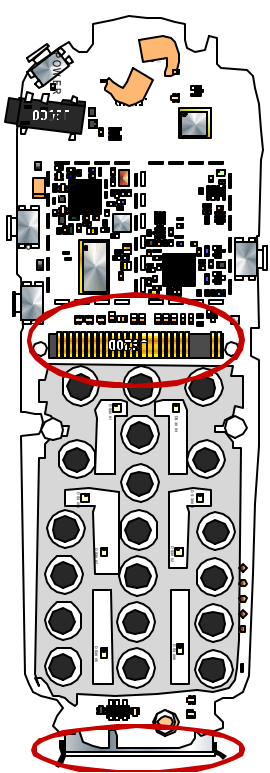
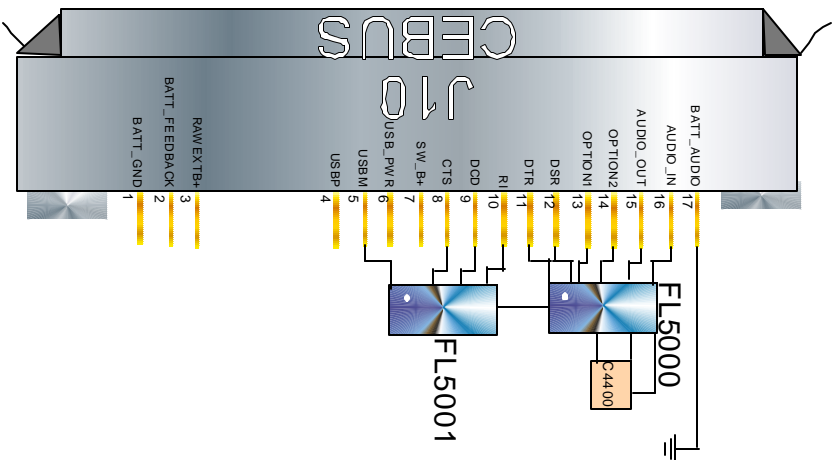

PWR (PM) A10b

V120 E

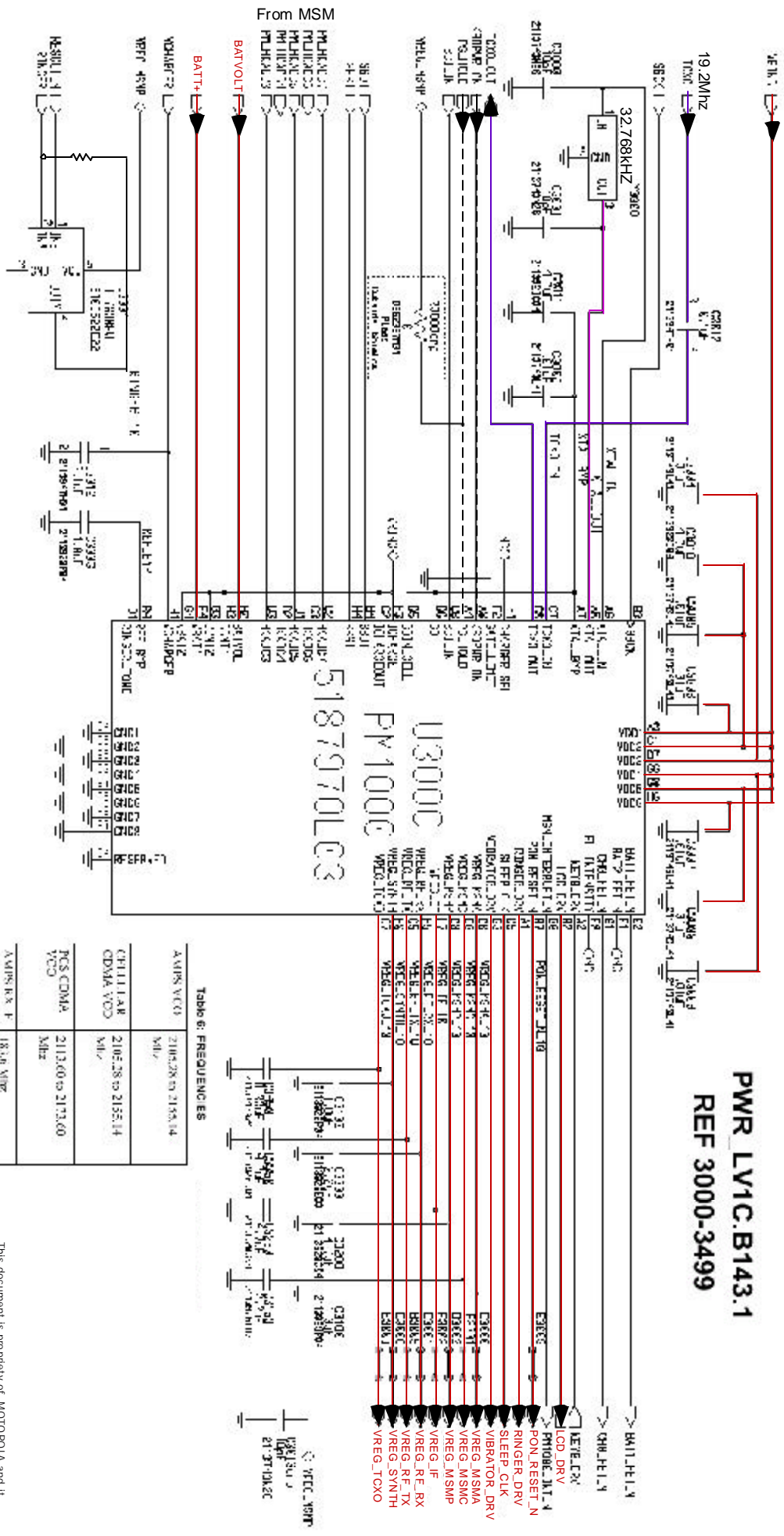
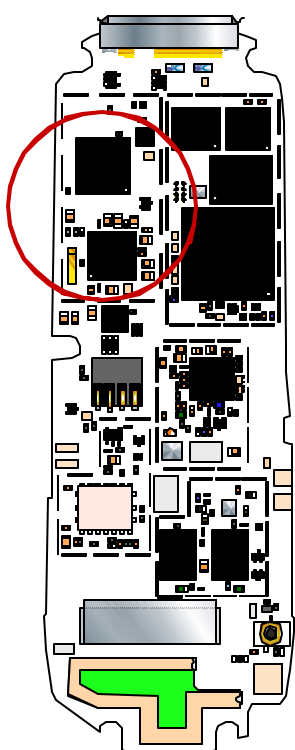

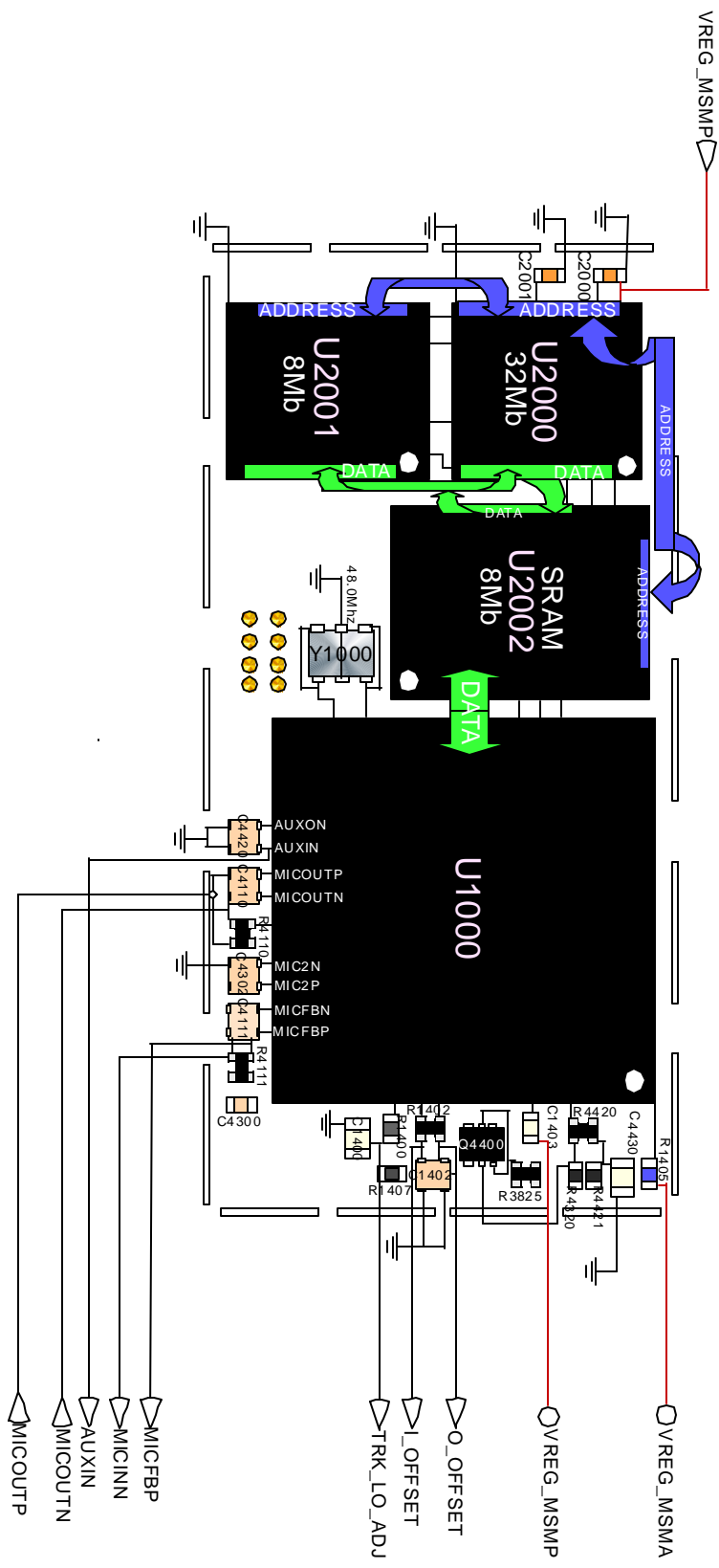
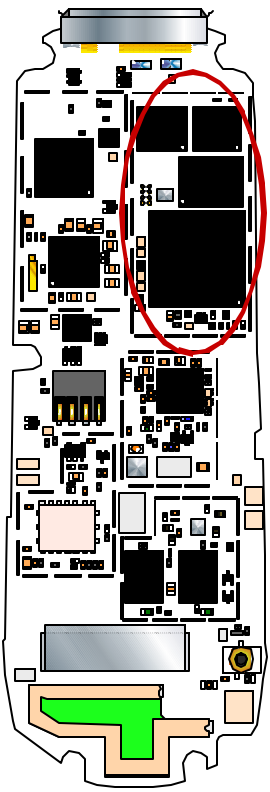

This document is property of MOTOROLA and it should be return if not used. Distribution and copies of this document are not allowed with out MOTOROLA approval.

MOTOROLA CONFIDENTIAL PROPRIETARY

BOARD - L07

MSM A11b

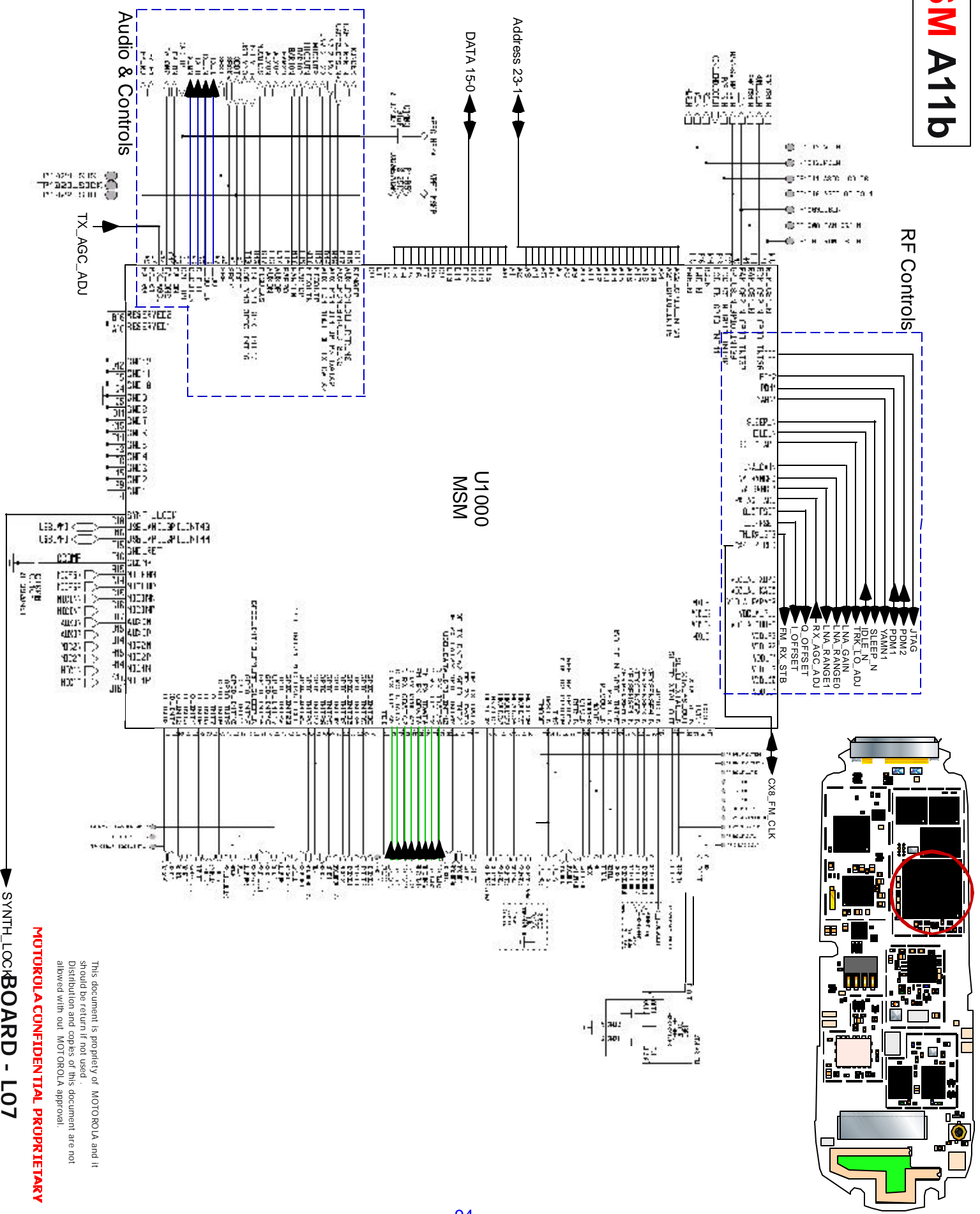

U1000
MSM

This document is property of MOTOROLA and it should be returned if not used. Distribution and copies of this document are not allowed without MOTOROLA approval.

MOTOROLA CONFIDENTIAL PROPRIETARY

BOARD - L07

RECEIVER AUDIO

Output from IFR 3000/3300 IC signals
C_RX_Q(DATA0,

DATA1,DATA2,DATA3) and
C_RX_I(DATA2,DATA3),

FM_RX_IDATA, FM_RX_QDATA these
signals carries the baseband signal of the
receive digital call to MSM5105.

The received QPSK data is gain controlled
and converted to digital, the Rx data stream
is then decoded by the CSP inside the MSM
to produce a signal containing only the
desired data.

The digital speech is further decoded by the
QCELP vocoder a part of the DSP within
MSM and then converted back into analog
receive audio and routed to the speaker.

TRANSMITTER AUDIO

Audio from the Microphone is routed to the
MSM5105 where it is digitized by the
CODEC inside MSM and the DSP within
processes by QCELP variable rate vocoder
and then coded by the Modem (CSP) which
produces CDMA data stream.

This stream is then converted to analog sig-
nals and send to RFT3100 IC on four lines
TX_I, TX_Q, TX_IN and TX_QN. This
modulates on the TX IF (QPSK Modulation)
228.6Mhz (263.6Mhz for PCS).

FREQUENCIES

AMPS VCO	2105.28 to 2155.14 Mhz
CELLULAR CDMA VCO	2105.28 to 2155.14 Mhz
PCS CDMA VCO	2113.60 to 2173.60 Mhz
AMPS RX IF	183.6 Mhz
CELLULAR CDMA RX IF	183.6 Mhz
PCS CDMA RX IF	183.6 Mhz

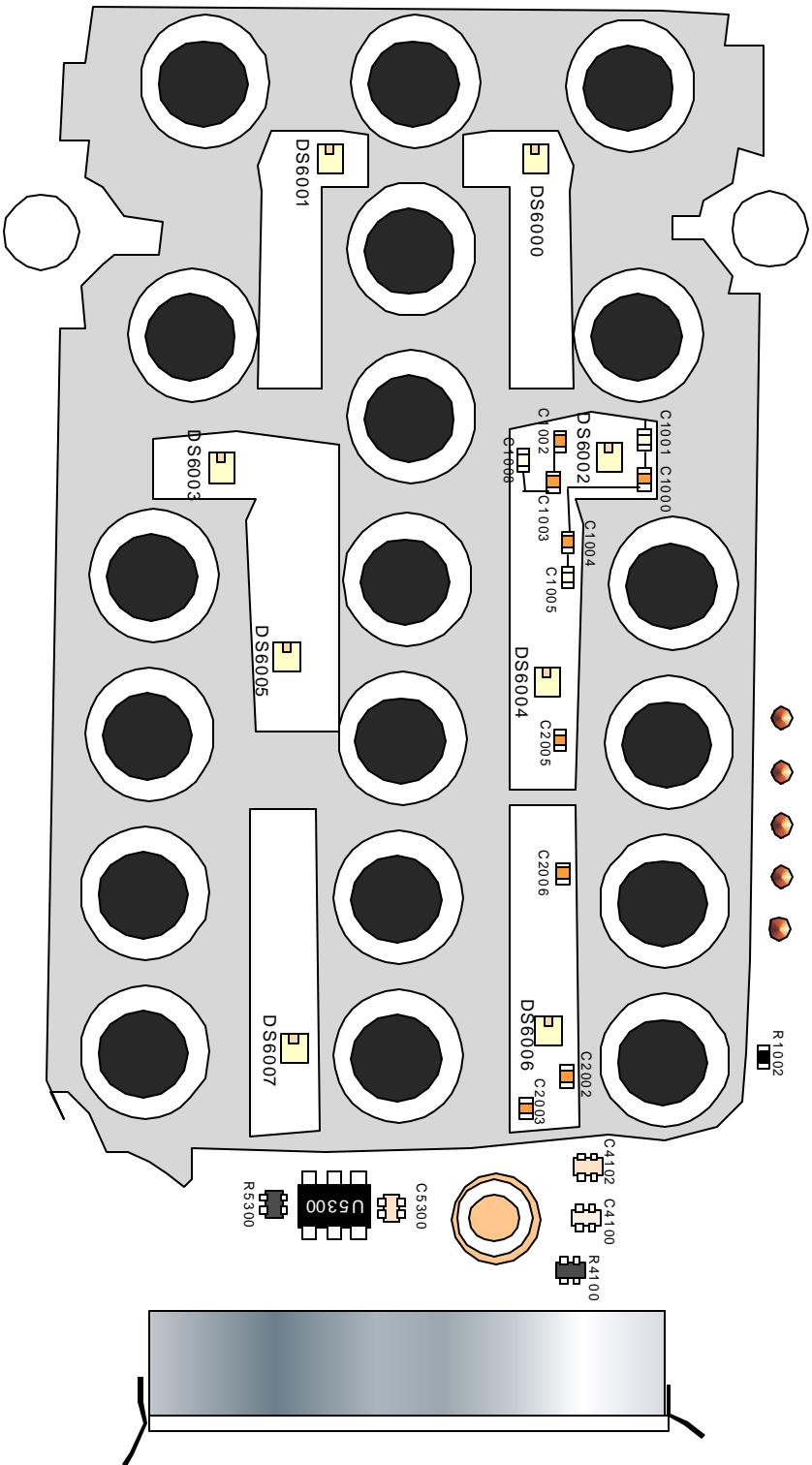

This document is property of MOTOROLA and it should be return if not used. Distribution and copies of this document are not allowed with out MOTOROLA approval.

V120E AGPS

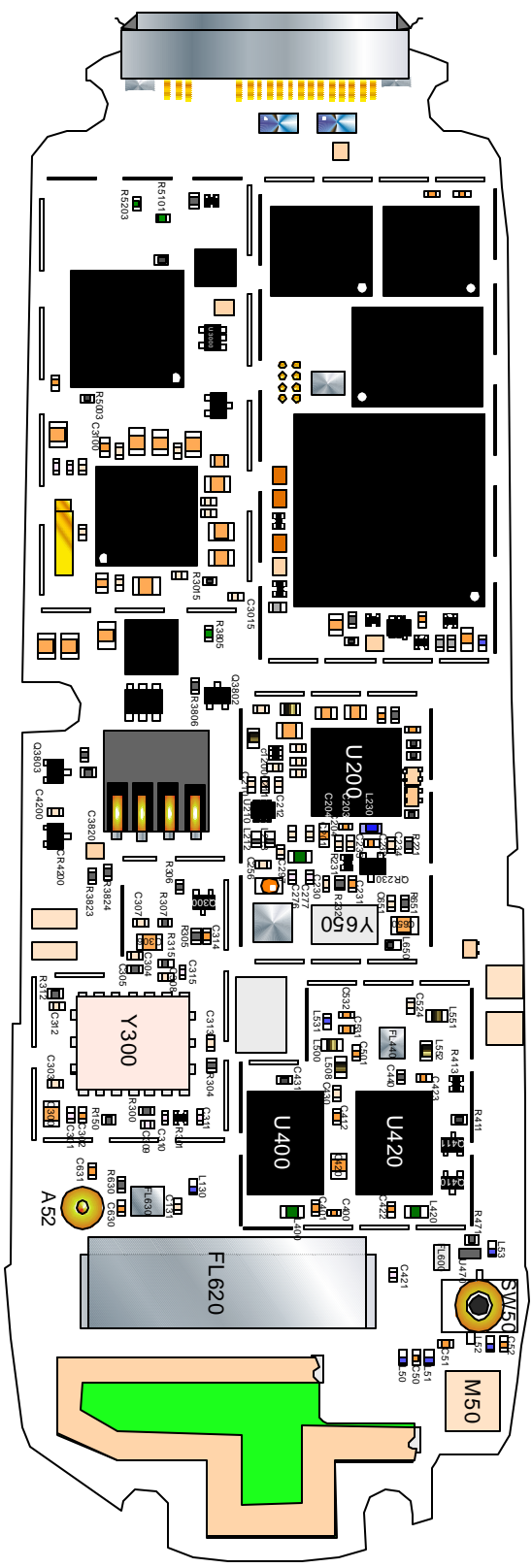

This document is property of MOTOROLA and it should be return if not used.
Distribution and copies of this document are not allowed with out MOTOROLA approval.

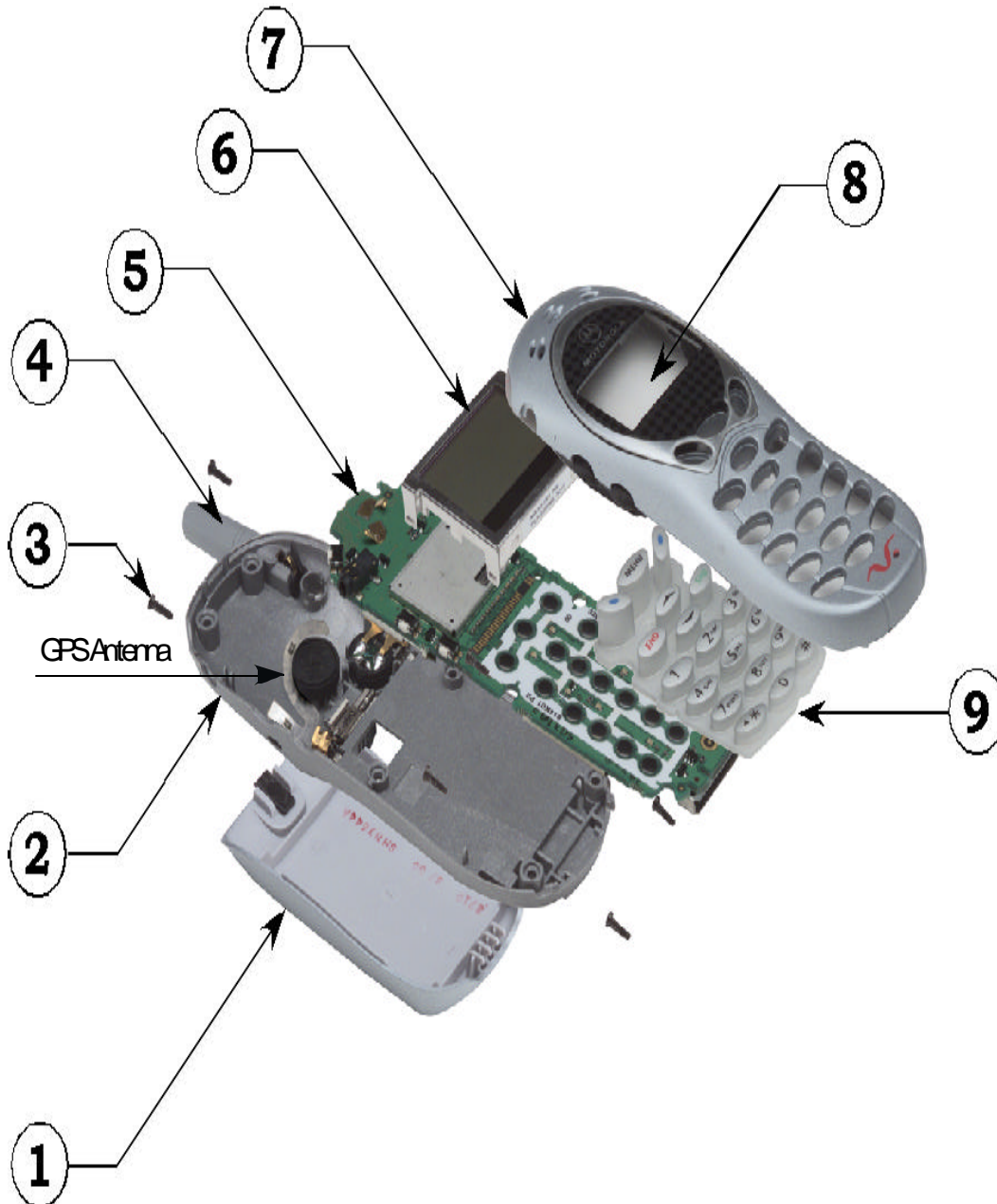

MECHANICAL PARTS LIST

1. SHN8061A	Battery Door
2. 1588875K06	HSNG REAR ASSY GRAY W/O GLSR
3. 0309315B12	SCREW TORX PL
4. 8589650K19	ANT TELESCOPIC V120
5. 8489788L02	PCB, Main Portable
6. 7202879Z85	96X64 GRAPHIC
7. 1588865K05	HSNG FRNT ASSY V120 1X SLVR
8. 6188789K05	LENS V120 1X GRAY/SILVER
9. 3888526L05	KYPD CDMA/TDMA GENERIC
1388750K14	ESC V120 SLVR Sprint
1209189A92	TSPEC CDMA1X
1209191A86	TSPEC XCVR LABEL INSTR
5402393T02	008 1 LABEL VADER
SHN8059A	H&H TRPN1X FRNT SILVER
5085600J01	MIC ELECTRET COND W/ELAST CON
5087975K02	SPEAKER 15DX2.7 TALL W/PADS
SHN8062A	H&H TRPN1X GRAY
0587903L02	GROMMET RF PLUG COLORED
5009005J10	ALERT 12MM 3.8DIA V120
5987947K08	VIBRATOR ASSY GROMMET
SYN0308A	HW GENERIC V120 1X C
4088527L01	MYLAR V120
SLG4302AA	V120 1X GPS MAIN BRD
010951A41	V120 1X GPS SIDE
010951A42	V120 1X GPS SIDE

ELECTRICAL PARTS LIST**Top Side Parts List**

Reference Des	Part Number	Description
A10	8489788L02	PCB INTERNAL ANT
C1200	2113743L41	CAP CHIP 10000 PF
C1201	2113743L33	CAP CHIP 4700 PF
C131	2113743N24	CAP CHIP 8.2 PF +
C1400	2113928P04	CAP CER CHIP 1.0U
C1402	2113947H01	CAP DL ARRAY 100
C1403	2113743L41	CAP CHIP 10000 PF
C200	2113928C04	CAP CER CHIP 4.7U
C2000	2113928N01	CAP CER CHIP 0.1U
C2001	2113928N01	CAP CER CHIP 0.1U
C201	2113928P04	CAP CER CHIP 1.0U
C202	2113743L41	CAP CHIP 10000 PF
C203	2113928N01	CAP CER CHIP 0.1U
C204	2113743N50	CAP CHIP 100 PF 5
C205	2113928P04	CAP CER CHIP 1.0U
C206	2113743L41	CAP CHIP 10000 PF
C207	2113928N01	CAP CER CHIP 0.1U
C208	2113743N50	CAP CHIP 100 PF 5
C209	2113743K16	CAP CHIP .220 UF
C210	2113743L17	CAP CHIP 1000 PF
C211	2113743L17	CAP CHIP 1000 PF
C212	2113743L17	CAP CHIP 1000 PF
C220	2113743L17	CAP CHIP 1000 PF
C223	2113928N01	CAP CER CHIP 0.1U
C224	2113947C01	CAP DL ARRAY 1000
C226	2113743L17	CAP CHIP 1000 PF
C227	2113743N50	CAP CHIP 100 PF 5
C230	2113743L41	CAP CHIP 10000 PF
C231	2113928N01	CAP CER CHIP 0.1U
C232	2113743N16	CAP CHIP 3.9 PF +
C233	2113743N50	CAP CHIP 100 PF 5
C234	2113743N50	CAP CHIP 100 PF 5
C235	2113947B05	CAP DL ARRAY 33.0
C237	2113743N40	CAP CHIP 39.0 PF
C256	2113743L17	CAP CHIP 1000 PF
C276	2113743N50	CAP CHIP 100 PF 5
C277	2113743N50	CAP CHIP 100 PF 5
C280	2113743L17	CAP CHIP 1000 PF
C281	2113743L17	CAP CHIP 1000 PF
C297	2113743L17	CAP CHIP 1000 PF
C300	2311049A69	CAP TANT CHIP 10.
C3000	2113743N26	CAP CHIP 10.0 PF
C3001	2113743N26	CAP CHIP 10.0 PF
C3002	2113743L41	CAP CHIP 10000 PF
C3003	2113928P04	CAP CER CHIP 1.0U

C3004	2113743L41	CAP CHIP 10000 PF
C3005	2113743L41	CAP CHIP 10000 PF
C3006	2113743L41	CAP CHIP 10000 PF
C3007	2113743L41	CAP CHIP 10000 PF
C3008	2113743L41	CAP CHIP 10000 PF
C3009	2113743L41	CAP CHIP 10000 PF
C301	2113743N50	CAP CHIP 100 PF 5
C3010	2113928C04	CAP CER CHIP 4.7U
C3011	2113928C04	CAP CER CHIP 4.7U
C3012	2113928N01	CAP CER CHIP 0.1U
C3014	2113743L17	CAP CHIP 1000 PF
C3015	2113743N40	CAP CHIP 39.0 PF
C302	2113928N01	CAP CER CHIP 0.1U
C303	2113743L41	CAP CHIP 10000 PF
C304	2113743L17	CAP CHIP 1000 PF
C305	2113743N40	CAP CHIP 39.0 PF
C306	2113928C04	CAP CER CHIP 4.7U
C307	2113743L41	CAP CHIP 10000 PF
C308	2113743L17	CAP CHIP 1000 PF
C309	2113743N26	CAP CHIP 10.0 PF
C310	2113743N26	CAP CHIP 10.0 PF
C3100	2113928P04	CAP CER CHIP 1.0U
C311	2113743N26	CAP CHIP 10.0 PF
C312	2113743L33	CAP CHIP 4700 PF
C313	2113743N50	CAP CHIP 100 PF 5
C314	2113743L33	CAP CHIP 4700 PF
C315	2113743N26	CAP CHIP 10.0 PF
C3150	'2113928E03	CAP CERAMIC CHIP
C3200	2113928C04	CAP CER CHIP 4.7U
C3250	2113928C04	CAP CER CHIP 4.7U
C3300	'2113928E03	CAP CERAMIC CHIP
C3350	2113928C04	CAP CER CHIP 4.7U
C3400	2113928P04	CAP CER CHIP 1.0U
C3450	2113743A24	CAP CHIP .330 UF
C3800	2113928P04	CAP CER CHIP 1.0U
C3802	2113743A31	CAP CHIP 1.0 UF 1
C3803	2113928C12	CAP CER CHIP 10.0
C3804	2113928C12	CAP CER CHIP 10.0
C3820	2113947B05	CAP DL ARRAY 33.0
C400	2113743N10	CAP CHIP 2.2 PF +
C401	2113743N16	CAP CHIP 3.9 PF +
C4110	2113947H01	CAP DL ARRAY 100
C4111	2113947B05	CAP DL ARRAY 33.0
C412	2113743N30	CAP CHIP 15.0 PF
C420	2113928C04	CAP CER CHIP 4.7U
C4200	2113743N40	CAP CHIP 39.0 PF
C4201	2113947B05	CAP DL ARRAY 33.0
C421	2113743N26	CAP CHIP 10.0 PF
C422	2113743N40	CAP CHIP 39.0 PF
C423	2113743L41	CAP CHIP 10000 PF

C430	2113743L41	CAP CHIP 10000 PF
C4300	2113743N40	CAP CHIP 39.0 PF
C4302	2113947H01	CAP DL ARRAY 100
C431	2113743N28	CAP CHIP 12.0 PF
C440	2113743N40	CAP CHIP 39.0 PF
C4400	2113947H01	CAP DL ARRAY 100
C4420	2113947H01	CAP DL ARRAY 100
C4430	2113928P04	CAP CER CHIP 1.0U
C5000	2113928N01	CAP CER CHIP 0.1U
C5001	2113928N01	CAP CER CHIP 0.1U
C501	2113928N01	CAP CER CHIP 0.1U
C51	2113743N32	CAP CHIP 18.0 PF
C5100	2113947H01	CAP DL ARRAY 100
C52	2113743N40	CAP CHIP 39.0 PF
C5201	2113928N01	CAP CER CHIP 0.1U
C524	2113743L17	CAP CHIP 1000 PF
C531	2113743N50	CAP CHIP 100 PF 5
C532	2113743N65	CAP CHIP 8.0PF 16
C630	2113743N07	CAP CHIP 1.5 PF +
C650	2113928C04	CAP CER CHIP 4.7U
C651	2113743L41	CAP CHIP 10000 PF
CR230	4809877C28	DIODE VARAC DUAL
CR5000	4809606E08	DIODE DUAL SCHOTT
FL250	9109142L09	FLTR XTAL 3POLE 1
FL430	9185782G03	FLTR CER TX 1800/
FL440	9103913K16	FLTR SAW BP 836MH
FL5000	4889526L01	IPD ESD FLTR 6CH
FL5001	4889526L02	IPD ESD FLTR 4CH
FL600	9185906G09	FLTR CER DIPLX 85
FL620	9185911J14	FLTR CER DP 1880/
FL630	9109239M19	FLTR SAW BP 1575M
J10	0987636K06	CONN I/O
J20	3988787K01	CONT BAT BLOCK TA
L130	2409154M06	IND CER MLTILYR 2
L212	2409154M48	IND CER MLTILYR 1
L213	2409154M48	IND CER MLTILYR 1
L220	2409377M19	IND CHIP WW 120 N
L221	2409377M19	IND CHIP WW 120 N
L230	2485793G06	IND CHIP WW 15 NH
L253	2409414M31	IND CHIP WW 150NH
L273	2409646M96	IND CER MULTILYR
L400	2409646M93	IN CER MULTILYR 3
L420	2409646M82	IN CER MULTILYR 1
L50	2409154M12	IND CER MLTILYR 8
L500	2409377M19	IND CHIP WW 120 N
L508	2409377M19	IND CHIP WW 120 N
L52	2409154M96	IND CER MLTILYR 4
L53	2409154M96	IND CER MLTILYR 4
L531	2409154M13	IND CER MLTILYR 1
L551	2409377M19	IND CHIP WW 120 N

L552	2409377M19	IND CHIP WW 120 N
L650	2409154M48	IND CER MLTILYR 1
Q300	4809608E03	TSTR DIG PNP DTA1
Q3800	4809939C39	TRANS DUAL NPN/PN
Q3802	4809579E02	TSTR MOSFET N-CHA
Q3803	4809579E02	TSTR MOSFET N-CHA
Q3804	4809579E29	TSTR FET P-CHAN S
Q410	4809608E03	TSTR DIG PNP DTA1
Q411	4809608E03	TSTR DIG PNP DTA1
Q4400	4809939C39	TRANS DUAL NPN/PN
R1200	0609591M25	RES CHIP DUAL 1K
R1400	0662057M82	RES. CHIP 2200 5
R1402	0609591M37	RES CHIP DUAL 10K
R1405	0662057V60	RES CHIP 8.25 K 1
R1407	0662057N27	RES. CHIP 150K 5
R150	0662057M50	RES. CHIP 100 5%
R221	0662057M98	RES. CHIP 10K 5
R231	0609591M37	RES CHIP DUAL 10K
R232	0662057M70	RES. CHIP 680 5%
R300	0662057M50	RES. CHIP 100 5%
R301	0609591M13	RES CHIP DUAL 100
R3015	0662057M58	RES. CHIP 220 5%
R304	0662057M50	RES. CHIP 100 5%
R305	0662057M98	RES. CHIP 10K 5
R306	0662057M28	RES. CHIP 12 5%
R307	0662057M28	RES. CHIP 12 5%
R312	0662057N09	RES. CHIP 27K 5
R315	0662057M28	RES. CHIP 12 5%
R3800	0662057M78	RES. CHIP 1500 5
R3801	0662057M86	RES. CHIP 3300 5
R3802	0662057M98	RES. CHIP 10K 5
R3803	0662057N09	RES. CHIP 27K 5
R3806	0662057N09	RES. CHIP 27K 5
R3823	0662057M90	RES. CHIP 4700 5
R3824	0662057M43	RES. CHIP 51 5%
R3825	0609591M37	RES CHIP DUAL 10K
R411	0662057N09	RES. CHIP 27K 5
R4110	0609591M37	RES CHIP DUAL 10K
R4111	0609591M53	RES CHIP DUAL 220
R413	0609591M37	RES CHIP DUAL 10K
R4320	0662057N09	RES. CHIP 27K 5
R4420	0609591M37	RES CHIP DUAL 10K
R4421	0662057N09	RES. CHIP 27K 5
R471	0662057M43	RES. CHIP 51 5%
R5000	0609591M07	RES CHIP DUAL 33
R5002	0662057M78	RES. CHIP 1500 5
R5003	0662057N09	RES. CHIP 27K 5
R51	0662057M01	RES. CHIP 0 5%
R5100	0662057M01	RES. CHIP 0 5%
R5201	0609591M49	RES CHIP DUAL 100

R5201	0609591M49	RES CHIP DUAL 100
R5204	0662057M90	RES. CHIP 4700 5
R5205	0662057N09	RES. CHIP 27K 5
R630	0662057M98	RES. CHIP 10K 5
R651	0662057M50	RES. CHIP 100 5%
SW50	0987378K01	CONN RF MOD3
U1000	5109962C26	IC MOB STA MODEM
U200	5109817F67	IC RX IF-BASEBAND
U2000	5185130C97	IC SAWTOOTH
U2001	5199342A01	IC FLASH ROM 512K
U2002	5109509A43	IC SRAM 512X16 70
U210	5109572E39	IC GAAS SPDT RF S
U3000	5187970L03	IC PWR MAN SCI CT
U3001	5109522E22	IC SNGL AND GATE
U3800	5187970L19	IC LITH ION BATT
U400	5109908K63	IC PA2001-5C 1900
U420	5109908K62	IC PA2001-4C 800M
U470	5885811G07	CPLR CER MLTLYR 1
U5000	5109962C21	IC CE BUS ASIC
U5100	5187970L07	IC ADV USB TRANSC
U5200	5109781E37	IC VOLT CMPTR PST
U5201	4809579E39	TSTR FET DUAL FDG
Y1000	4887820K03	RESON CER 48MHZ 2
Y300	4889695L06	MOD VCO/SYNTH 139
Y3000	4809995L14	XTAL 32KHZ 20PPM
Y650	4809718L15	OSC MOD TCXO 19.2

Bottom Side Electrical Parts List

Ref Des#	Part #	Description
C100	2113947C01	CAP DL ARRAY 1000
C1000	2113928N01	CAP CER CHIP 0.1U
C1001	2113743L41	CAP CHIP 10000 PF
C1002	2113928N01	CAP CER CHIP 0.1U
C1003	2113743L41	CAP CHIP 10000 PF
C1004	2113928N01	CAP CER CHIP 0.1U
C1005	2113743L41	CAP CHIP 10000 PF
C1008	2113928N01	CAP CER CHIP 0.1U
C101	2113947C01	CAP DL ARRAY 1000
C102	2113947C01	CAP DL ARRAY 1000
C112	2113743N40	CAP CHIP 39.0 PF
C113	2113743N03	CAP CHIP 1.0 PF +
C114	2113743N40	CAP CHIP 39.0 PF
C115	2113743N40	CAP CHIP 39.0 PF
C117	2113743L41	CAP CHIP 10000 PF
C120	2113743L41	CAP CHIP 10000 PF
C121	2113743N28	CAP CHIP 12.0 PF
C122	2113743N10	CAP CHIP 2.2 PF +
C124	2113743L41	CAP CHIP 10000 PF
C125	2113743N07	CAP CHIP 1.5 PF +
C132	2113743N07	CAP CHIP 1.5 PF +
C134	2113743N14	CAP CHIP 3.3 PF +
C150	2113743N44	CAP CHIP 56.0 PF
C1500	2113743L41	CAP CHIP 10000 PF
C1501	2113743L33	CAP CHIP 4700 PF
C1502	2113928N01	CAP CER CHIP 0.1U
C2002	2113928N01	CAP CER CHIP 0.1U
C2003	2113928N01	CAP CER CHIP 0.1U
C2005	2113928N01	CAP CER CHIP 0.1U
C2006	2113928N01	CAP CER CHIP 0.1U
C253	2113743L17	CAP CHIP 1000 PF
C271	2113743N19	CAP CHIP 5.1 PF +
C272	2113743N50	CAP CHIP 100 PF 5
C273	2113743L17	CAP CHIP 1000 PF
C274	2113743L17	CAP CHIP 1000 PF
C290	2113743N07	CAP CHIP 1.5 PF +
C291	2113743N50	CAP CHIP 100 PF 5
C292	2113743L17	CAP CHIP 1000 PF
C293	2113743L17	CAP CHIP 1000 PF
C294	2113743N26	CAP CHIP 10.0 PF
C295	2113743N09	CAP CHIP 2.0 PF +
C296	2113743N26	CAP CHIP 10.0 PF
C4002	2113743K16	CAP CHIP .220 UF

C4003	2113743K16	CAP CHIP .220 UF
C4100	2113947B05	CAP DL ARRAY 33.0
C4102	2113947H01	CAP DL ARRAY 100,
C4312	2311049A89	CAP TANT CHIP 22
C490	2113928N01	CAP CER CHIP 0.1U
C491	2113743L29	CAP CHIP 3300 PF
C492	2113743N28	CAP CHIP 12.0 PF
C500	2113743N50	CAP CHIP 100 PF 5
C502	2113743N40	CAP CHIP 39.0 PF
C503	2113743L29	CAP CHIP 3300 PF
C504	2113743N50	CAP CHIP 100 PF 5
C505	2113743L01	CAP CHIP 220 PF 1
C506	2113743L01	CAP CHIP 220 PF 1
C507	2113743N40	CAP CHIP 39.0 PF
C508	2113743N40	CAP CHIP 39.0 PF
C509	2113743N50	CAP CHIP 100 PF 5
C510	2113743N65	CAP CHIP 8.0PF 16
C511	2113743N60	CAP CHIP 5.0PF 16
C513	2113743N50	CAP CHIP 100 PF 5
C516	2113743N30	CAP CHIP 15.0 PF
C517	2113743N30	CAP CHIP 15.0 PF
C518	2113743N12	CAP CHIP 2.7 PF +
C519	2113743L21	CAP CHIP 1500 PF
C520	2113743L05	CAP CHIP 330 PF 1
C522	2113743L17	CAP CHIP 1000 PF
C530	2113743N44	CAP CHIP 56.0 PF
C5300	2113947H01	CAP DL ARRAY 100,
C550	2113743N50	CAP CHIP 100 PF 5
C6510	2113928P04	CAP CER CHIP 1.0U
C6511	2113928P04	CAP CER CHIP 1.0U
C6513	2113928P04	CAP CER CHIP 1.0U
C6514	2113928P04	CAP CER CHIP 1.0U
C6517	2113928P04	CAP CER CHIP 1.0U
C6518	2113928P04	CAP CER CHIP 1.0U
C6519	2113928P04	CAP CER CHIP 1.0U
C6520	2113928P04	CAP CER CHIP 1.0U
C6521	2113928P04	CAP CER CHIP 1.0U
C6522	2113947B05	CAP DL ARRAY 33.0
C6523	2113947B05	CAP DL ARRAY 33.0
C6524	2113947B05	CAP DL ARRAY 33.0
CR4201	4809606E08	DIODE DUAL SCHOTT
CR500	4809948D39	DIODE PIN BAR63-0
CR501	4809877C29	DIODE VARAC DUAL
CR502	4809877C29	DIODE VARAC DUAL
DS6000	4809496B11	LED CHIP YEL-GRN
DS6001	4809496B11	LED CHIP YEL-GRN
DS6002	4809496B11	LED CHIP YEL-GRN
DS6003	4809496B11	LED CHIP YEL-GRN
DS6004	4809496B11	LED CHIP YEL-GRN
DS6005	4809496B11	LED CHIP YEL-GRN

DS6006	4809496B11	LED CHIP YEL-GRN
DS6007	4809496B11	LED CHIP YEL-GRN
FL110	9185673J02	FLTR SAW INT 800M
FL120	9109239M08	FLTR SAW BP 1960M
FL130	9109239M18	FLTR SAW BP 1575M
FL260	9185646H09	FLTR SAW IF 183.6
FL610	9109170T04	FLTR DUPLX 836.5/ CONN JACK 2.5 DIA
J30	0987837L02	CONTACT, SPEAKER,
J40	3989328K01	CONTACT, SPEAKER,
J41	3989328K01	CONTACT, SPEAKER,
L111	2409154M48	IND CER MLTILYR 1
L112	2409154M16	IND CER MLTILYR 1
L113	2409154M37	IND CER MLTILYR 1
L114	2409154M17	IND CER MLTILYR 2
L115	2409154M34	IND CER MLTILYR 6
L120	2409154M10	IND CER MLTILYR 5
L121	2409154M96	IND CER MLTILYR 4
L122	2409154M96	IND CER MLTILYR 4
L123	2409154M10	IND CER MLTILYR 5
L124	2409154M04	IND CER MLTILYR 1
L131	2409154M11	IND CER MLTILYR 6
L132	2409154M06	IND CER MLTILYR 2
L250	2409377M19	IND CHIP WW 120 N
L251	2409377M19	IND CHIP WW 120 N
L270	2409646M96	IND CER MULTILYR
L271	2409646M96	IND CER MULTILYR
L272	2409377M13	IND CHIP WW 56 NH
L290	2409154M96	IND CER MLTILYR 4
L291	2409154M96	IND CER MLTILYR 4
L292	2485793G13	IND CHIP WW 56 NH
L293	2485793G13	IND CHIP WW 56 NH
L501	2409154M37	IND CER MLTILYR 1
L502	2409154M32	IND CER MLTILYR 4
L504	2409154M15	IND CER MLTILYR 1
L505	2409154M15	IND CER MLTILYR 1
L506	2485793G03	IND CHIP WW 6.8NH
L507	2485793G03	IND CHIP WW 6.8NH
L550	2409377M19	IND CHIP WW 120 N
Q1500	4809939C39	TRANS DUAL NPN/PN
Q490	4809939C39	TRANS DUAL NPN/PN
Q501	4809939C39	TRANS DUAL NPN/PN
R100	0609591M13	RES CHIP DUAL 100
R1002	0662057M98	RES. CHIP 10K 5
R101	0609591M13	RES CHIP DUAL 100
R102	0662057M50	ES. CHIP 100 5%
R103	0662057M50	ES. CHIP 100 5%
R140	0662057V60	RES CHIP 8.25 K 1
R141	0662057U96	RES CHIP 6.2K 1%
R1500	0609591M25	RES CHIP DUAL 1K
R250	0662057M84	RES. CHIP 2700 5

R254	0662057M01	RES. CHIP 0 5%
R270	0662057M86	RES. CHIP 3300 5
R291	0662057M84	RES. CHIP 2700 5
R4100	0609591M29	RES CHIP DUAL 2.2
R430	0662057V61	RES CHIP 12.1 K 1
R4300	0609591M25	RES CHIP DUAL 1K
R4306	0609591M29	RES CHIP DUAL 2.2
R4333	0662057N23	RES. CHIP 100K 5
R490	0609591M25	RES CHIP DUAL 1K
R492	0662057M43	RES. CHIP 51 5%
R493	0662057V61	RES CHIP 12.1 K 1
R500	0662057M98	RES. CHIP 10K 5
R505	0662057V61	RES CHIP 12.1 K 1
R508	0609591M37	RES CHIP DUAL 10K
R510	0662057M98	RES. CHIP 10K 5
R530	0662057M43	RES. CHIP 51 5%
R5300	0609591M49	RES CHIP DUAL 100
RT430	0685660C01	THERMISTOR 3% 040
SW6000	4009368L08	SW TACT RT ANG 3
SW6001	4009368L08	SW TACT RT ANG 3
SW6002	4009368L08	SW TACT RT ANG 3
SW6003	4009368L08	SW TACT RT ANG 3
U130	5109944C50	IC RF-TO-IF REC D
U4300	5109731C24	IC OP AMP SNGL LM
U480	5887694L23	ATTEN 50 OHM 20 D
U490	5109768D10	IC PWR DETECTOR 2
U500	5109944C48	IC TRANSMIT PROCE
U5300	5109817F58	IC CURRENT LIM SW
VR4000	4809948D44	4 CHANNEL ESD ARR
VR4300	4809948D44	4 CHANNEL ESD ARR
VR6000	4809948D44	4 CHANNEL ESD ARR
VR6001	4809948D44	4 CHANNEL ESD ARR

