



MOTOROLA
Cellular Subscriber Sector

P7382i / P7389i



GSM Service Support

Training - Documentation - Engineering

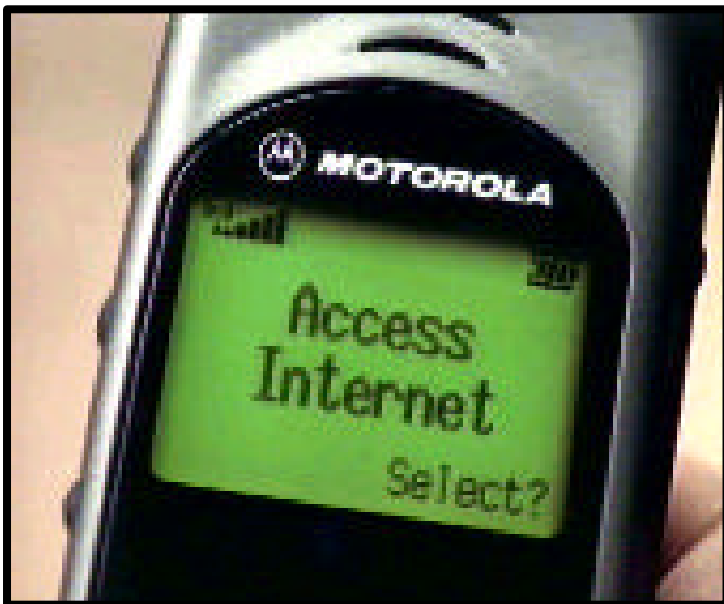

Level III Service Manual

P7382i - 1900 MHz GSM

P7389i - 900 / 1800 / 1900 Tri-Band MHz GSM

CONTENTS

		Page Number
<u>SECTION 1: GENERAL</u>		
1.1	Introduction	v
1.2	Motorola service policy for P7382i / P7389i in warranty	vi
1.3	General Safety Information	vii
<u>SECTION 2: P7382i / P7389i DESCRIPTION</u>		
2.1	Specifications of P7382i / P7389i	2
2.2	P7382i / P7389i Overview	3
2.3	Connector Pinout	5
2.4	Talk time, Weight and Volume Matrix	5
<u>SECTION 3: FEATURE LIST</u>		
3.1	List of Features available	7
3.2	Menu	7
3.3	Phone Book	7
3.4	Call Related Features	8
3.5	Messages	9
3.6	Phone Set Up	10
3.7	Network selection	11
3.8	Call Meters	11
3.9	Accessory set-up	12
<u>SECTION 4: DISASSEMBLY & PARTS</u>		
4.1	Dissassembly Introduction	14
4.2	Recommended Tools	14
4.3	Disassembly Procedure	14
4.4	Assembly procedure	14
4.5	Exploded Parts diagram	19
4.6	Replacement parts	20
<u>SECTION 5: SIM CARDS AND SECURITY</u>		
5.1	Manual test mode	22
5.2	Live Sim Card	22
5.3	Personality Transfer	22
5.4	GSM Test Command	24
5.5	Identity and Security	25

SECTION 6: REPAIR & TEST PROCEDURES

6.1	Repair introduction	27
6.2	Mechanical repairs	27
6.3	Basic modular troubleshooting	27
6.4	Software Upgrade	30
6.5	Flexing	30
6.6	Testing on HP 8922	31
6.7	Testing IrDA Port	31
6.8	Testing on Go / NoGo Tester	32

SECTION 7: ACCESSORIES

7.1	Accessory Statement	34
7.2	Mid Rate Charger Information	34
7.3	Accessory Listing	35

SECTION 8: GLOSSARY OF TERMS

8.1	List of Abbreviations	37
-----	-----------------------	----

SECTION 1: GENERAL

1.1 Introduction

This manual is intended for use by technicians familiar with similar types of equipment. It contains all service information required for the equipment described and is current as of the printing date.

The scope of this document is to provide the reader with basic information relating to the P7382i / P7389i, and also to provide procedures and processes for repairing the units up to and including Level 2 repair.

Level 1 and 2 repairs involve the following activities to be carried out: -

- Unit swap out
- Repairing of mechanical faults
- Basic modular troubleshooting
- Testing and verification of unit functionality
- Upgrading software
- Flexing units
- Initiate warranty claims and send faulty modules to Level 3 or 4 repair centres.

Computer Software Copyrights

The Motorola products described in this instruction manual may include copyrighted Motorola computer programs stored in semi-conductor memories or other media. Laws in the United States and other countries preserve for Motorola certain exclusive rights for copyrighted computer programs, including the exclusive right to copy or reproduce in any form the copyrighted computer program. Accordingly, any copyrighted Motorola computer programs contained in the Motorola products described in this instruction manual may not be copied or reproduced in any manner without the express written permission of Motorola. Furthermore, the purchase of Motorola products shall not be deemed to grant either directly or by implication, estoppel, or otherwise, any license under the copyrights, patents or patent applications of Motorola, except for the normal non-exclusive, royalty free license to use that arises by operation of law in the sale of a product.

1.2 Motorola Service Policy for P7382i / P7389i in warranty

1.2.1 Warranty:

Product will be sold with the standard 12 months warranty terms and conditions. Accidental damage misuse, retailers extended warranties will not be supported under warranty. Non warranty repairs will be available at agreed fixed repair prices.

Proof of purchase will be required to validate warranty claims.

1.2.2 Out of Box Failure Policy

The standard OOB failure criteria will apply. Customer units that fail very early on, after date of sale, are to be returned to Manufacturing for root cause analysis, to guard against epidemic criteria.

Manufacturing to bear the costs of early life failure.

1.2.3 Product Support

Customers original units will be repaired but not refurbished as standard. Appointed Motorola Service Hubs will perform warranty and non-warranty field service for level 2 (assemblies) and level 3 (limited PCB component). The Motorola HTC centres will perform level 4 (full component) repairs.

1.2.4 Customer Support:

This will be available through dedicated Call Centres and In Country Help Desks.

Product Service training should be arranged through the local Motorola Support Centre.

1.2.5 Replacement Parts Ordering

Only centres authorized to carry out repairs will be able to purchase spare parts. Orders for spare parts from Hub's and Hi-Tech Centres should be placed with the regional Motorola Parts Distribution Centre.

1.3 General Safety Information

1.3.1 Portable Operation

- DO NOT hold the radio so that the antenna is very close to, or touching, exposed parts of the body, especially the face or eyes whilst transmitting. The radio will perform best if it is held in the same manner as you would hold a 'land' telephone handset, with the antenna angled up and over your shoulder.
- DO NOT operate the portable phone in an aircraft. Switch off your telephone. The use of a cellular telephone in an aircraft may be dangerous to the operation of the aircraft, disruption of the Cellular Network may occur, and is illegal. Failure to observe this instruction may lead to a suspension or denial of Cellular Telephone Service to the offender, or legal action, or both.

1.3.2 Mobile/Portable Operation - Telephone use in Vehicles:

- All equipment must be properly grounded according to installation instructions for safe operation.
- Users are advised to turn off their equipment when at a refueling point.
- Safety is every driver's responsibility. Cellular telephones should only be used in situations in which the driver considers it safe to do so.

1.3.3 General

- DO NOT allow children to play with any radio equipment containing a transmitter.
- DO NOT operate this equipment near electrical blasting caps or in an explosive atmosphere. Mobile Telephones are, under certain conditions, capable of interfering with blasting operations. When you are in the vicinity of such work, look out for and observe signs cautioning against mobile radio transmission. If transmission is prohibited, you must turn off your mobile telephone to prevent any transmission. In standby mode the mobile telephone will automatically transmit to acknowledge a call if it is not turned off.
- Refer to the appropriate section of the product user manual for additional pertinent safety information
- All equipment should be serviced only by a Motorola qualified technician.

**SECTION 2:
P7382i / P7389i
DESCRIPTION**

2.1 Specifications of P7382i / P7389i

General

Function	Specification
Frequency Range GSM	880-915 MHz TX (with EGSM) 925-960 MHz RX
Frequency Range DCS	1710-1785 MHz Tx 1805-1880 MHz Rx
Frequency Range PCS	1850.2 – 1909.8 MHz Tx 1930.2 – 1989.8 MHz Rx
Channel Spacing	200 kHz
Channels	174 GSM/374 DCS carriers with 8 channels per carrier
Modulation	GMSK at BT = 0.3
Transmitter Phase Accuracy	5 Degrees RMS, 20 Degrees peak
Duplex Spacing	45 MHz GSM 95MHz DCS 80MHz PCS
Frequency Stability	+ 0.10 ppm of the downlink frequency (Rx)
Operating Voltage	Full Rate PSU = 4.4V +/- 5% (During Charging = VBatt +/-5% 6.63V Mid Rate Charger = 5.9V +/- 0.3V CLA Supply = 4.4V Battery Operating Voltage = 2.85V(Radio Shut Down voltage) To 4.2V Max
Transmit Current	Typically 250 ma avg, 1.0A peak
Stand-by Current	Typically 7.0 ma (DRX2)
Dimensions	130mm x 46mm x 24.5mm
Size (Volume)	105cc with Batt
Weight	106g with Batt
Temperature Range	-10C to +55C

Transmitter

Function	Specification
RF Power Output	33 dBm \pm 2dB GSM/ 30 dBm \pm 2 dB DCS
Output Impedance	50 ohms (nominal)
Spurious Emissions	-36 dBm from 0.1 to 1 Ghz -30 dBm from 1 to 4 Ghz

Receiver

Function	Specification
RF Level	-102 dBm
RX bit error rate (100 k bits)	< 2%
Channel Hop Time	500 microseconds
Time to Camp	Approximately 5-10 seconds

Speech Coding

Function	Specification
Speech Coding Type	Regular Pulse Excitation / Linear Predictive Coding with Long Term Prediction. (RPE LPC with LTP).
Bit Rate	13.0 k bps
Frame Duration	20 ms
Block Length	260 bits
Classes	Class 1 bits = 182 bits. Class 2 bits = 78 bits
Bit Rate with FEC Encoding	22.8 k bps

2.2 P7382i / P7389i Overview

The P7382i / P7389i is of the new TRI-BAND technology allowing global roaming using the GSM 900 / 1800 / 1900 bands(see below). The following are a few of the features that will be included with the unit.

- Using the Whitecap lower voltage technology this offers good standby and talk times(see below)
- Extended GSM channels
- Tri-Codec allowing Full Rate / Half Rate / Enhanced Full Rate modes of transmission.
- SIM Toolkit.
- Enhanced Infrared Data link (see below)
- 3 Pin RS232 connection.
- 96 x 54 row full graphics Optimax™ with contrast control.
- Internal Headset
- Speaker Dependant Voice recognition (see below)
- Vibracall™
- Voicenotes™
- HATIS – Hearing aid Telephone Interconnection device.
- Language support for prompts,STK, SMS and Phonebook
- WAP 1.1. compliant
- Simplified Alpha Text Entry
- Calling Name Presentation
- Display Animation
- Call Divert Interrogation
- Concatenated SMS

The TRI – BAND technology will be implemented into the unit using bandaware technology for GSM 900 / 1800 and Knifeswitch selection should GSM 1900 selection be required. There will be 2 access choices for the user (1) through the menu structure - Network Selection, or (2) through the quick access key.

IrDA – Infra red Data Association, This feature will allow the user to link their mobile phone to their computer terminal. This will allow the user to upload and download information, such as phonebook information, SMS messages, FAX data etc... without the requirement for cables. The unit can also communicate with other IrDA devices such as pagers and other mobile phones.

Perfect alignment of the beam is not required due to the spread of the beam.

IP SMS allows SMS messages to be constructed on a PC then downloaded to the P7382i / P7389i to be transmitted.

IP Phonebook allows very easy and extremely flexible download / upload of phonebook information, enabling select phonebooks available to each user, which can be quickly changed for example when travelling to different areas.

The last 10 calls made and received can also be downloaded allowing databases to be created.

The P7382i / P7389i can be placed into IrDA mode via either the quick access menu or through the Phone Set up menu structure 'Activated' will appear on the screen once the feature has been selected followed by 'Connection Made' once transfer of data is available between the P7382i / P7389i and the other device. The P7382i / P7389i software allows more devices to be synchronised with phone e.g. Win NT, Psion and Palm.

Speaker Dependant Voice Recognition – This feature allows 'Voice Tags' to be allocated to upto 25 names within the users phone memory and also upto 15 Voice tags be allocated to the quick access functions. The unit must be 'trained' for this function (ie the voice tags must first be read into the phones memory twice before recognition can be made.)

Two main points whilst using this option.

*THERE WILL BE NO SERVICE DURING 'TRAINING' WHICH MEANS THE USER CANNOT RECEIVE OR MAKE CALLS DURING THIS TIME.

*THE VOICE TAGS CAN ONLY BE ADDED TO THE PHONES MEMORY, AS GSM DOES NOT ALLOW THE OPTION TO STORE VOICE TAGS ONTO THE SIM CARD.

Voice tags can be added to the phones memory using the usual name addition methods ie via the phonebook menu structure, using the M+ key, or using the quick access keys.

To make a call to a person allocated with a voice tag, the smart button must first be pressed, then the P7382i / P7389i will ask for a name, if the name is recognised, then the name will be repeated and displayed on the screen. A call can then be placed.

For access to one of the quick access functions the quick access key must first be pressed, a name will then be asked for, if the name is recognised e.g. Battery Meter then the name will be repeated and the corresponding feature e.g. the battery meter will be displayed on the screen.

If 2 names are too alike then the unit will request another name.

CUG (Closed User Group) This is a network application which allows a select group of users only to use a particular group of mobile units e.g. In the circumstance where a manager of a field service team only wants the team to be able to call other users within his team (or CUG).

Phase 2 USSD (Unstructured Supplementary Services Data) – This is an application whereby pressing a certain key or combination of keys whilst in idle mode ie not in a call can access certain network functions such as helplines etc...

- **WAP 1.1 Compliancy (Wireless Application Protocol) - WAP 1.1** Wireless Application Protocol

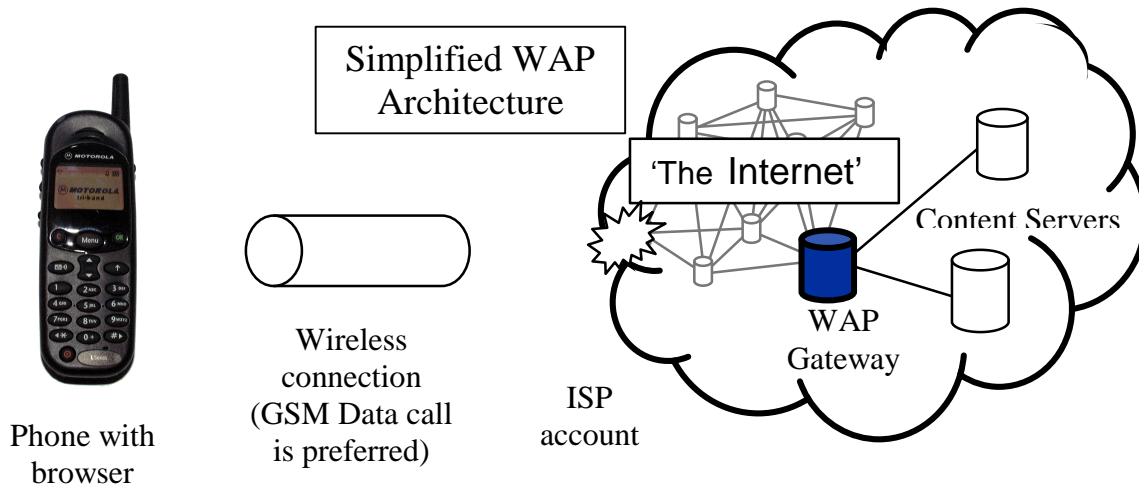

- In the WAP environment this is how the access is made.
 1. The request for information is made in WML (Wireless Markup Language) derived from HTML.
 2. Request is passed to WAP Gateway, which retrieves the information from the server in standard HTML (which is then filtered to WML) or if available WML format.
 3. The information is then passed the cellular user, via the cellular network provider.
- There will be 5 Data parameters that the user will be able to edit:
 - Baud rate - between 2400 and 14400
 - Idle time out
 - Line type
 - Phone Number
 - Connection type
- For image download, the bitmap image will be downloaded as text and if the image is larger than the screen then only part of the image will be displayed
- Ways to access Browser - Quick access key and Feature Menu

During browser mode, if incoming call is received then the browser will be paused with the user having the option to resume after the call.

Simplified Alpha Text Entry - This gives the allowance to use all forms of Roman and Chinese Key entry on a 96 X 54 display.

At present only Latin based characters can be entered using the multi tap key entry.

There are 3 forms of CKE (Chinese Key Entry):

- Pin Yin - Simplified Chinese (Mainland China)
- Bo-po-mo-pho - Complex Chinese (Taiwan)
- Stroke based method for both Simple and Complex
- Can be used with phone book and SMS features
- European and Pan American models will be able to switch between Roman and Latin Key Entry
- Asian Models will be able to switch between all Key entries.

Calling Name Presentation - This is an improvement on the existing name presentation.

- At present name from phone book is displayed by comparing last 8 digits of Number
- New feature will show name as sent by the network. This is up to 80 characters, but will be shortened to 12 for the phonebook.
- This functionality must be subscribed to with network.
- Caller can restrict this
- On call arrival phone Number is compared to phonebook if match is found but name is not allocated then callers name will be stored.(However if there is any text against that number it will not be overwritten)

Display Animation - Aimed at physically showing the customer is executing commands.

Existing animations are for Power up and Down sequences.

- New animations -
- Incoming / sending call
- Incoming / sending SMS
- IrDA Quick Access icon

Call Divert Interrogation - This function is just a more accurate way of ensuring that the caller is diverted to the correct number, this is mainly achieved through the co-operation of the network providers.

Concatenated SMS - Concatenated: A series of linked events

Increases the amount of characters that can be sent and received from the phone.

Currently can send 1 SMS of 160 characters and the SIM can store 10 of these.

New functionality will support 5 X 153 Character messages and the SIM will be able to hold between 30 and 75 slots dependant on type of card and memory already allocated, each slot will hold 160 characters.



2.3 Connector Pinouts



Charger Socket Pin Layout	
1.GND	2.SW_RF
3.GND	4.BATT_FDBK
5.MAN_TEST_AD	6.RS232_TX
7.RS232_RX	8.CHG_EN
9.ON_2*	10.GND
11.DSC_IN*	12.DOWNLINK
13.DSC_EN	EXT B+
15.GND	

2.4 Talk Times, Weight and Volume Matrix

Volume (cubic cm) Flat / Flip	Weight (grams)	Talk Time (minutes)	Standby time (hours)	With Battery type:
105 / 115	106 / 120	150 - 210	75 - 125	600mAh Li Ion
115 / 138	126 / 138	240 - 330	130 - 200	1000mAh Li
105 / 115	95 / 105	60 - 90	70 - 90	290mAh Li Polymer
115 / 138	136 / 145	150 - 240	100 - 200	600mAh NM (AAA)
130 / 155	155 / 165	480 - 660	260 - 410	2200mAh Li

SECTION 3: FEATURE LIST

3.1 List of Features Available

Below is the list of Menu functions available at present.

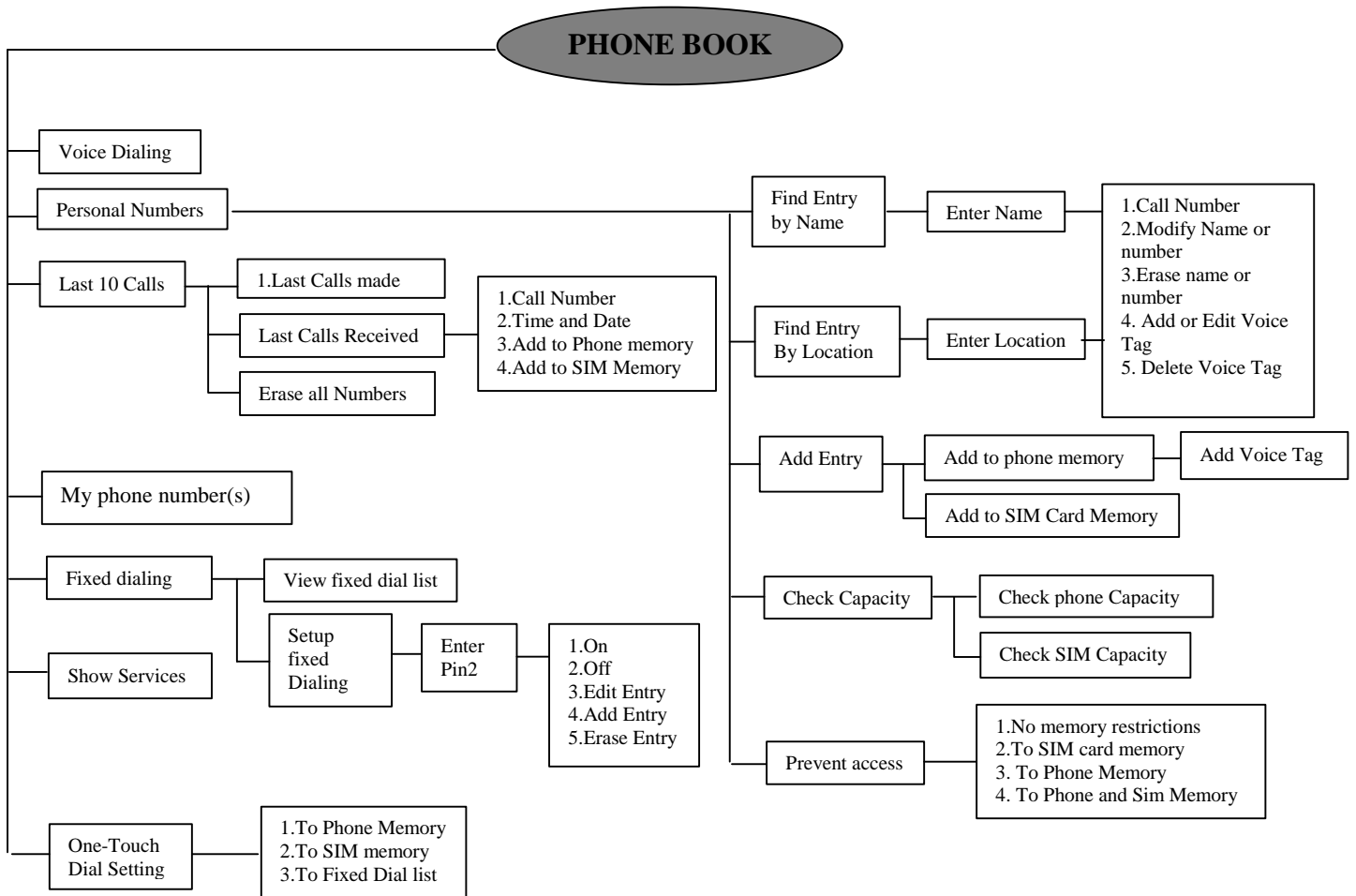
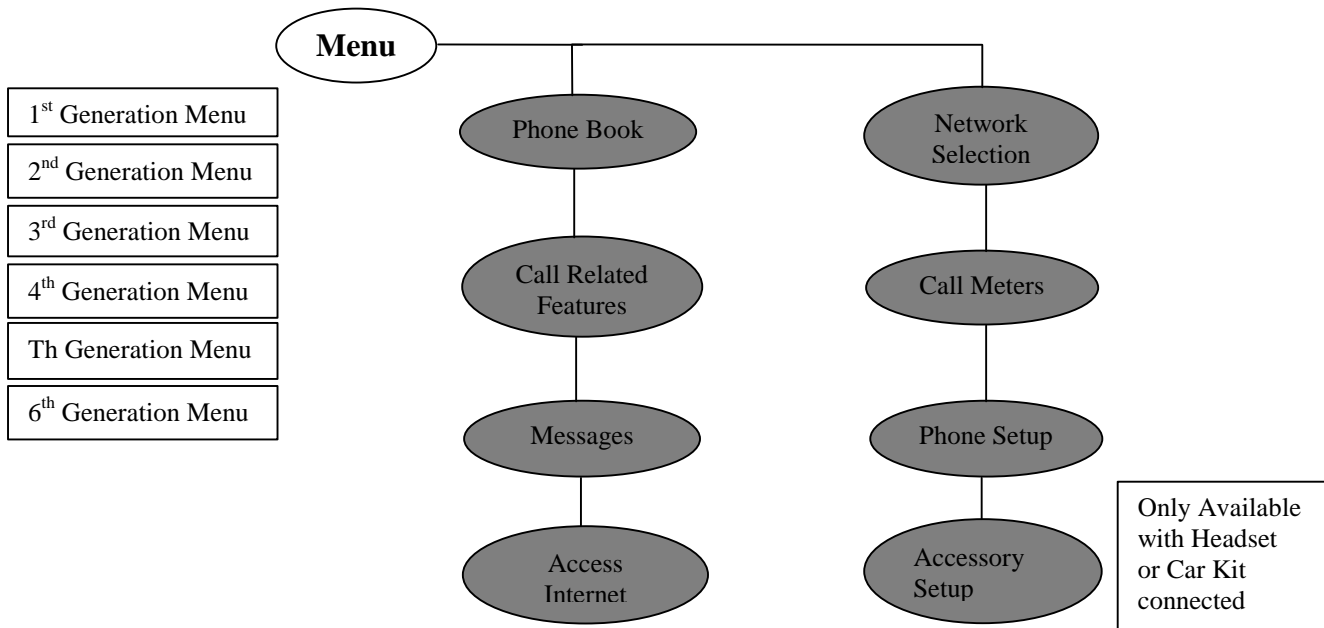

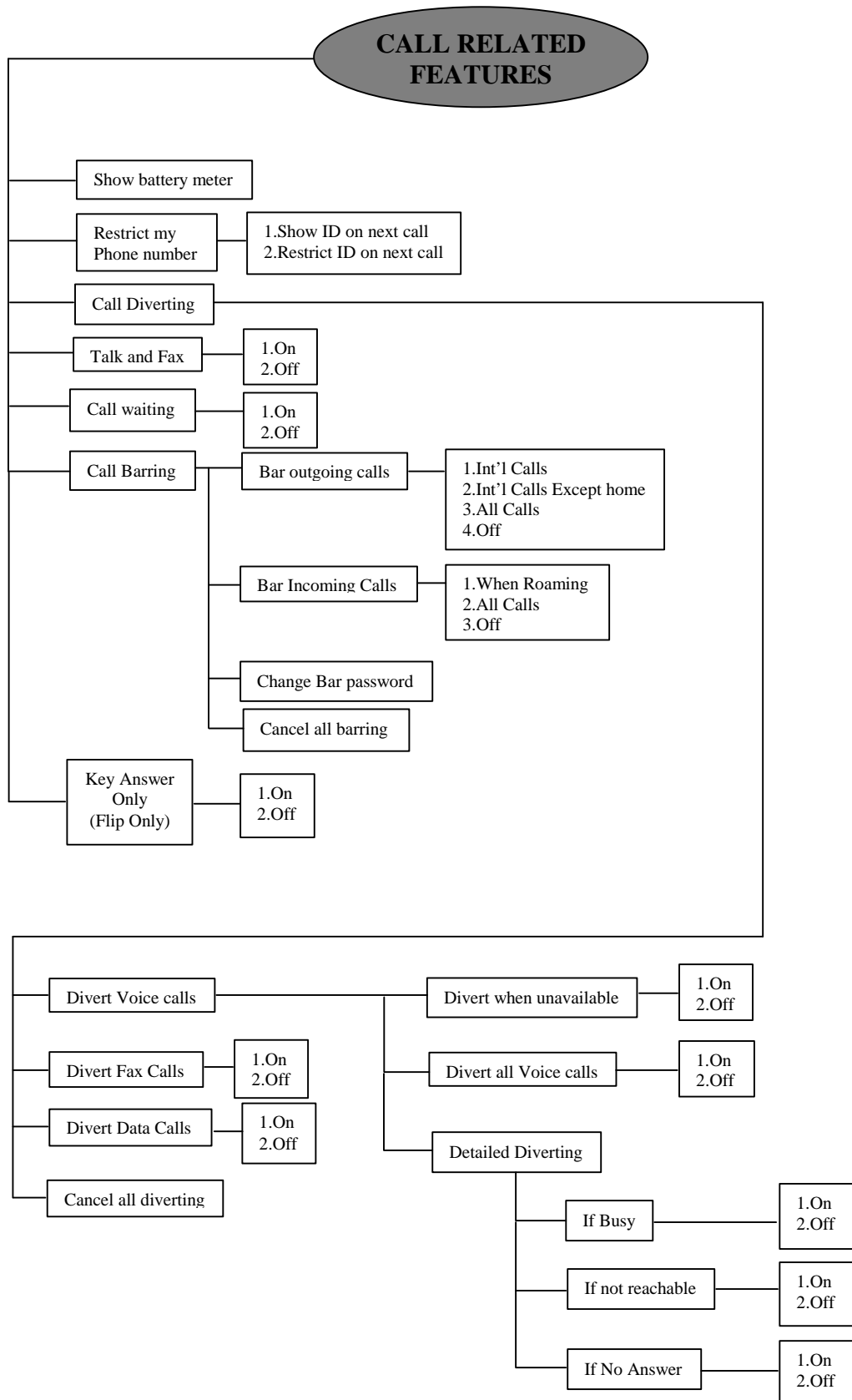

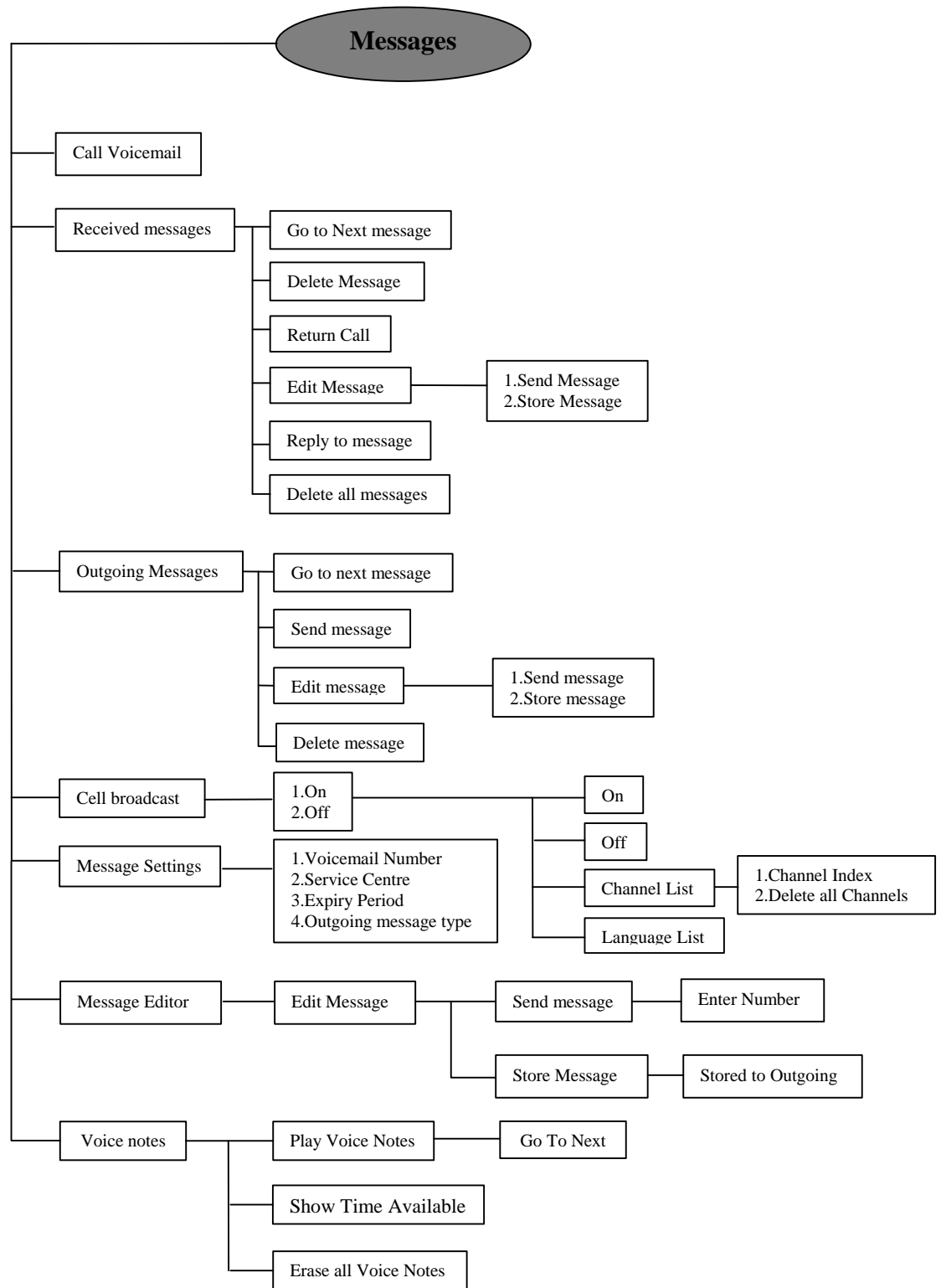

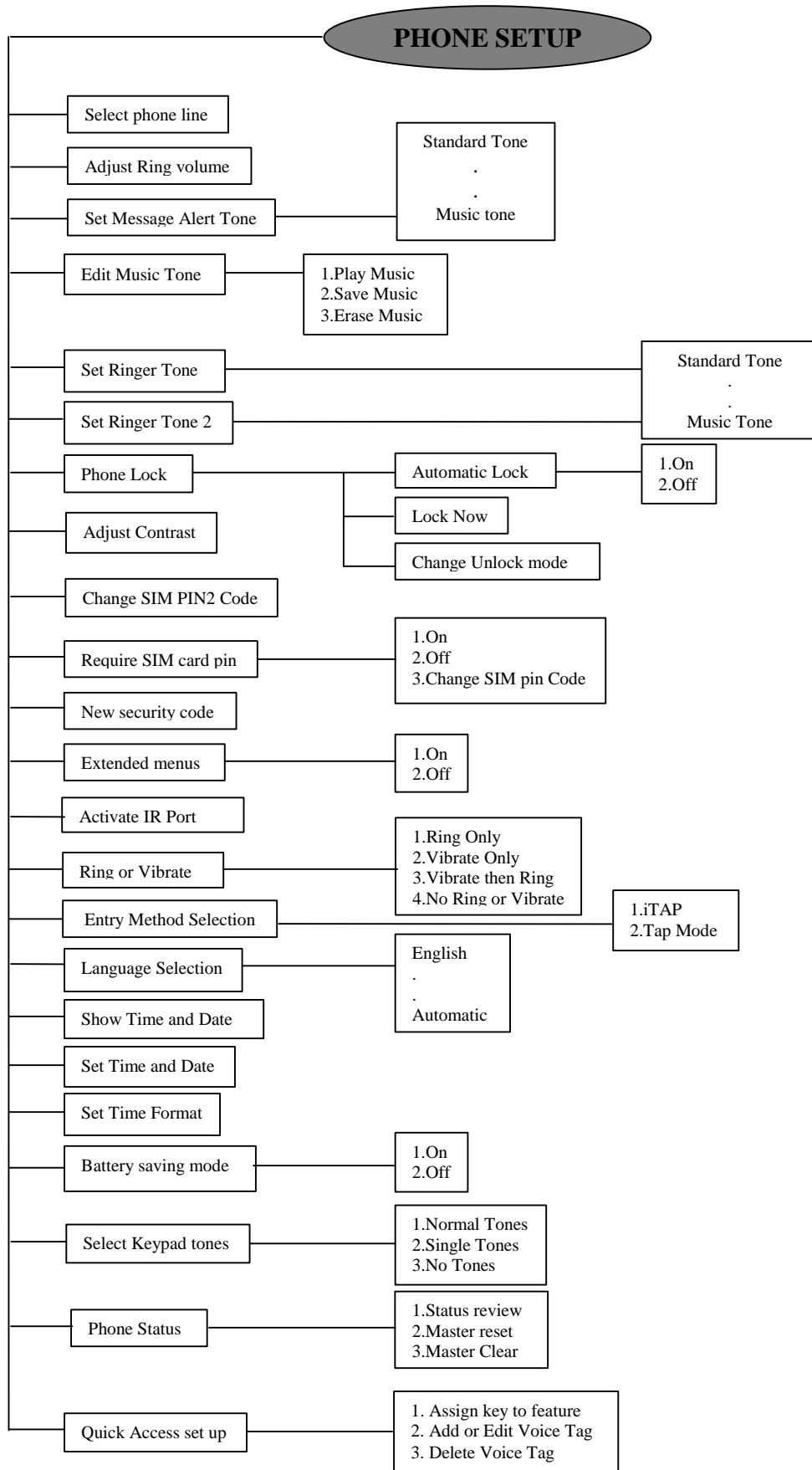

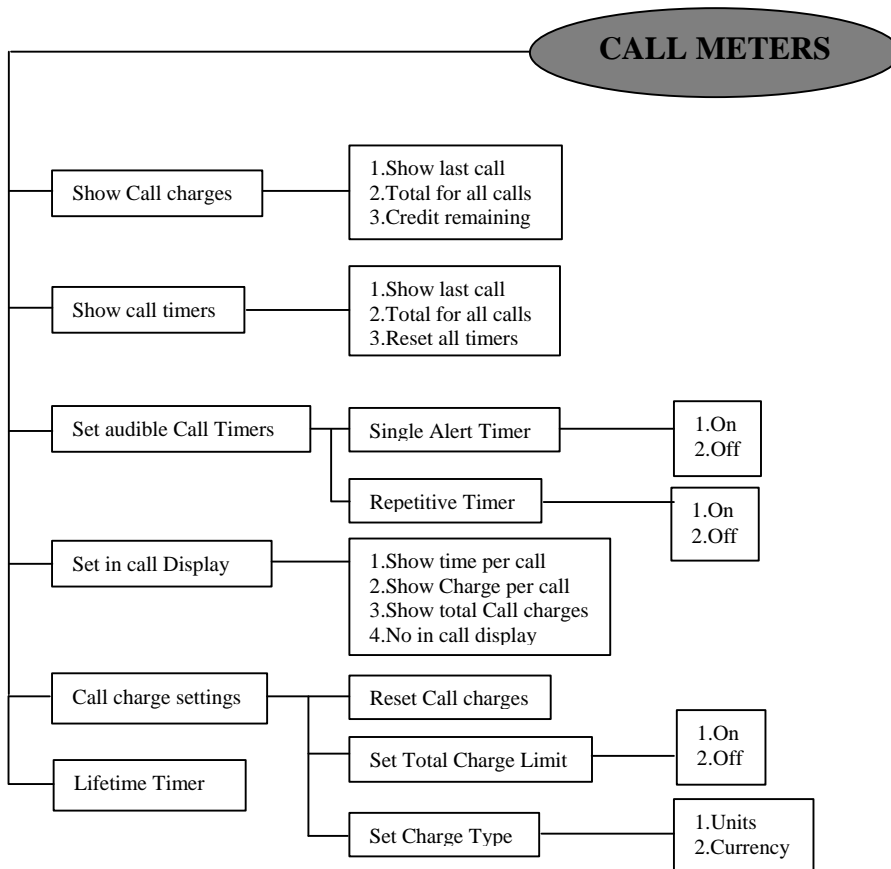
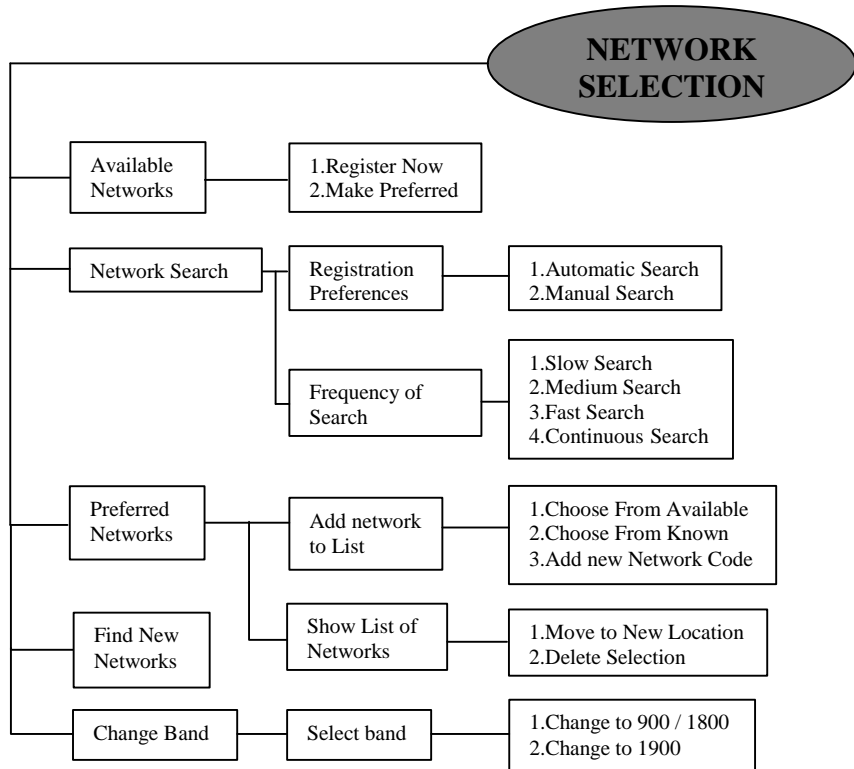

**ACCESSORY
SETUP**

NB. THIS MENU IS ONLY AVAILABLE WITH EITHER HEADSET PLUGGED IN OR WHEN INSTALLED IN A CAR KIT.

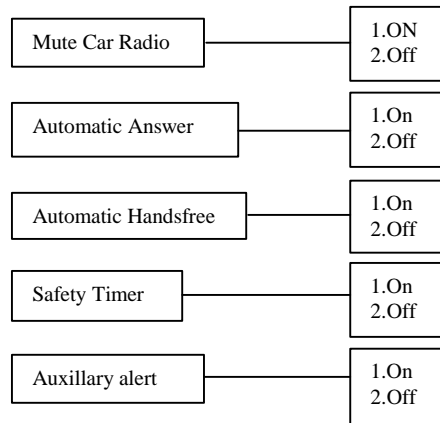

SECTION 4: DISASSEMBLY & PARTS

4.1 Disassembly Introduction

The P7382i / P7389i is held together by 6 screws. 2 of these screws are placed under the escutcheon, at the top of the phone. Unlike most products in the past there is no flex that holds the display module, this is held in place with 4 clips.

Ensure that a properly grounded high impedance conductive wrist strap is used whilst performing any tasks during the disassembly and assembly of the unit

Avoid stressing the plastics in any way to avoid damage to either the plastics or internal components.

!! CAUTION !!

Many of the intergrated devices used in this equipment are vulnerable to damage from electro-static charges. Ensure that adequate static protection is in place when handling, shipping and servicing the internal components of this equipment.

4.2 Recommended Tools

The following tools are recommended for use during the assembly / disassembly of the P7382i / P7389i.

- Anti-static Mat Kit - 0180386A82, includes:
Antistatic mat 66-80387A95
Ground Cord 66-80334B36
Wrist Band 42-80385A59
- Plastic Bladed Tool SLN7223A
- T5 Torx Driver

4.3 Disassembly Procedure

The following set of diagrams will demonstrate the correct sequence and action required to disassemble the P7382i / P7389i

The use of the exploded diagram on pages **19 & 20** may be of some assistance for part recognition.

4.4 Assembly Procedure

Once the unit is disassembled and the repair is carried out, the unit must then be reassembled, this is carried out in the exact reverse order as the disassembly.



1. Remove battery door by pressing down on clip and sliding back.



2. Remove battery by pushing and lifting at the same time.



3. Press down and push SIM cover to the left, then remove SIM card.



4. Remove Escutcheon from rear of unit.



5. Unscrew antenna
(Anti – Clockwise)



6. Unscrew all of the 6
screws.

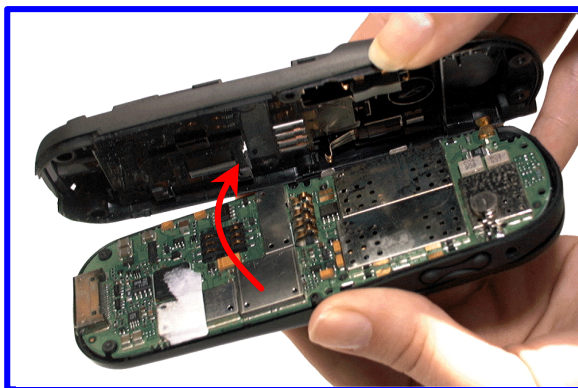

7. Remove the rear
from the front housing

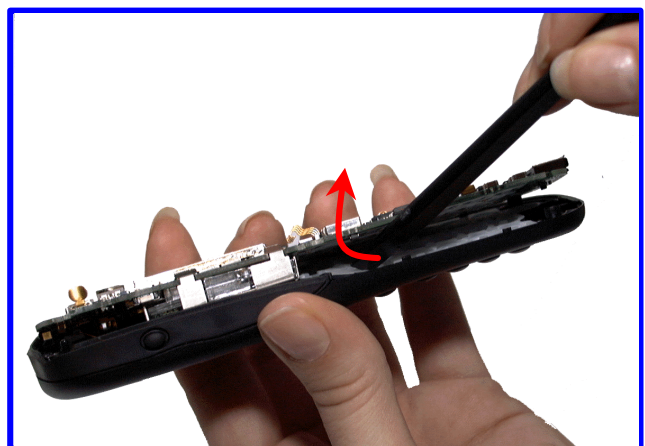

8. Levering from the side
opposite the headset socket,
carefully prize PCB from Front
Housing.

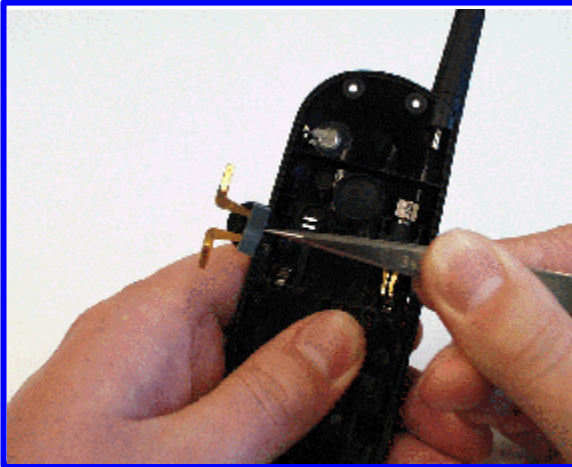

9. Remove Alert speaker from rear housing

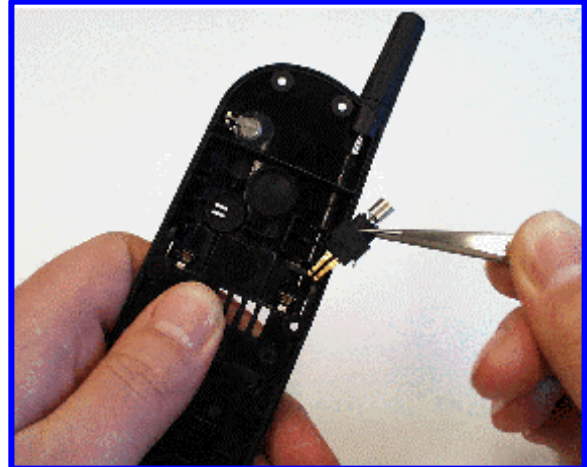

10. Remove vibrator from rear housing



13. Remove keypad from front housing



14. Remove flexible strip by holding the front housing facing downwards and pulling strip up



15. Carefully press down on Service Indicator, if it gets damaged / scratched during this process, replace.

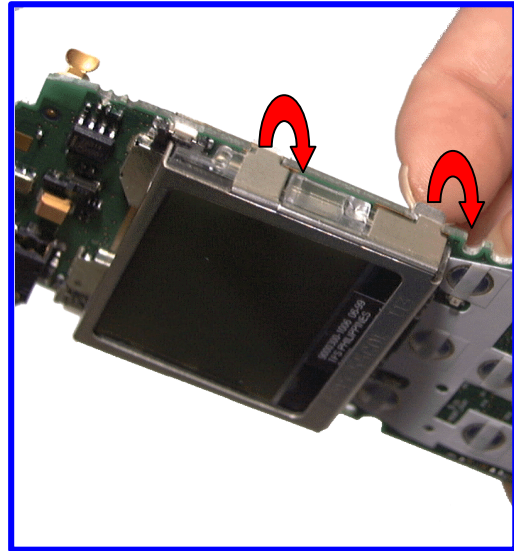

16. Unclip the 4 retaining catches remove the display module

4.5 Exploded Parts Diagram SUG1175A (Black)



4.6 Description of Parts for SUG1175A (Black / Flat)

*For Part numbers of other variants please consult Level 1&2 parts list)

Reference No	Description	Part Number
1	Spares Transceiver	S8505A
2	Front Hsng Assy	0103723S01
3	Volume buttons	3803750S03
4	Lens	6103756S01
5	Rear Housing	0103722S01
6	Vibrator	0185728J01
7	Light Pipe	0185956H01
8	Screw	0309315B07
9	Keypad	3885994H01
10	K/Pad Domes	4085804H01
11	Alert Spkr	5009005J07
12	Speaker	5009076E20
13	Mic (& Grommet)	5085600J01
14	Display Module	0185756G01
15	Battery (RTC)	6003710K08
16	Batt Door cover	SHN7094A
17	Antenna	8509397T01

SECTION 5: SIM CARDS AND SECURITY

5.1 Manual Test Mode

The GSM Motorola P7382i / P7389i is equipped with a manual test mode capability. This capability allows service personnel to take control of the unit, and by entering certain keypad commands, make the unit performs desired functions.

To enter the manual test command mode, a GSM / DCS test sim (Part No 8102430Z04) must be used. The test sim is inserted into the SIM slot beneath the battery (See **figure 6.1**), the battery should then be re-inserted and the unit powered on. The # button should then be pressed for approximately 3 second until 'test' appears on the display, and the correct commands must then be followed.

Figure 6.1 SIM Card insertion

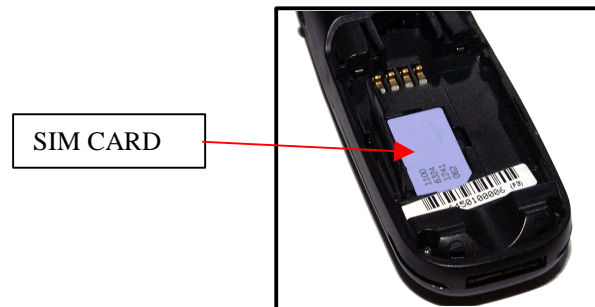

5.2 Live Sim Card

A SIM (Subscriber Identity module) card will be required to access the existing local GSM / DCS / PCS cellular network, or remote networks when travelling. (If the roaming agreement has been made with the provider.)

The SIM card contains all the data necessary to access GSM services, and also:

- The ability to store user information such as phone numbers etc...
- All information required by the network provider to provide use to the network

5.3 Personality Transfer

5.3.1 Introduction

Personality Transfers are required when a phone is Express Exchanged or when the main board is replaced. The reason for personality transfers are to reproduce the customer's original personalized details such as menu and stored memory such as phone books etc... or even just to program a unit with basic user information such as language selection. There are two possible methods of transferring this information from unit to unit, or with a master transfer, card to unit: -

- **Normal Transfer** is used when the customer's original unit still powers up and as discussed above the customers personalized menu selections etc... are required to be transferred to the replacement unit.
- **Master Transfer** is used when the faulty unit will not power up and the transfer is used to configure the replacement board to a set standard.

Below is the procedure to set up a Master Transfer Card and to carry out each method of transfer correctly.

5.3.2 Normal Transfer

1. Insert transfer card into 'Donor' Unit. Turn unit on till 'Clone' appears.
2. Enter **021#** to upload first block of data. 'Please wait' will be displayed.
3. Remove card.

4. Insert card into replacement unit, or unit with new main RF / Logic PCB.
5. Turn unit on wait till 'Clone' appears.
6. Enter **03#** 'Please wait' will be displayed while data is transferred.
7. Repeat steps 1 – 6 but enter **022#** at step 2 to transfer data on to Clone card.
8. Repeat steps 1 – 6 but enter **025#** at step 2 to transfer data on to Clone card.

5.3.3 Master SIM Card Creation

1. Insert transfer card into a unit with the desired setup Pwr on and wait till unit displays 'Clone'
2. Enter **024#** to copy unit 'personality' onto card. 'Please wait' will be displayed
3. Master Transfer card is created.

5.3.4 Master Transfer

1. Insert Master Transfer Card (explained above) into replacement unit. Pwr on and wait till unit displays 'Clone'
2. Enter **03#** to download data into replacement unit. Please wait will be displayed.
3. When 'Clone' reappears download is completed.

5.4 GSM Test Commands

This is a list of Level 1 and 2 Test commands available to P7382i / P7389i

Table 6.1 Test commands	<i>Test Function/Name</i>
#(hold down for 2 seconds)	Enter manual test mode
01#	Exit manual test mode
07x#	Mute RX audio path
08#	Unmute RX audio path
09#	Mute TX audio path
10#	Unmute TX audio path
15x#	Generate tone
16#	Mute tone generator
19#	Display S/W version number of Call Processor
20#	Display S/W version number of Modem
36#	Initiate acoustic loopback
37#	Stop test
38#	Activate Mini SIM
39#	Deactivate Mini SIM
43x#	Change audio path
47x#	Set audio volume
51#	Enable sidetone
52#	Disable sidetone
57#	Initialize non-volatile memory
58#	Display security code
58xxxxxx#	Modify security code
59#	Display lock code
59xxx#	Modify lock code
60#	Display IMEI
99#	Display all display pixels

15XX#		36XX#	
90#	Vibrator	0 or Omitted	Full Rate
91#	Ringer	1	Enhanced Full rate
		2	Half Rate

98#	
20#	GSM 1800
21#	GSM 900
22#	GSM 1900 (PCS)
23#	Dual Band 900 / 1800

5.5 Identity and Security

Each Motorola GSM Cellular Cassette will be labelled with various number configurations. The following information describes what these configurations mean.

MSN

The mechanical Serial Number (MSN) is an individual unit identity number and will remain with the unit throughout the life of the unit.

The MSN can be used to log and track a unit on Motorola’s EPPRS system.

The MSN is divided into 4 sections.

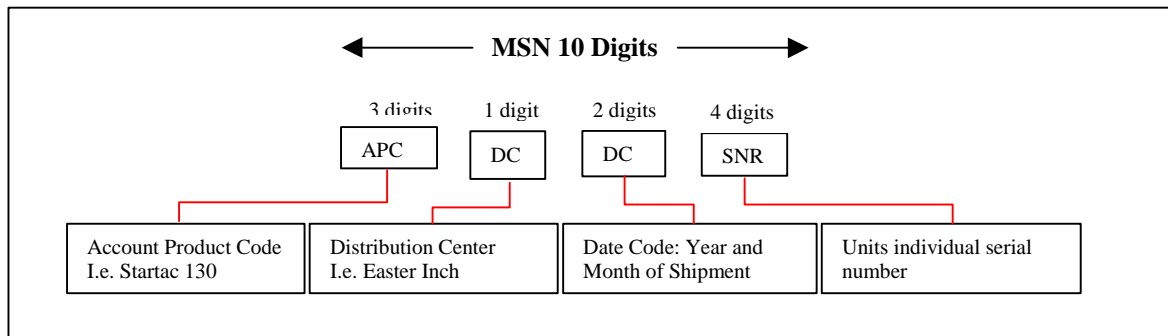

Figure 5.2 MSN label breakdown

IMEI

The International Mobile station Equipment Identity (IMEI) number is an individual number unique to the PCB and is stored within the unit’s memory. The following figure gives a description of the make up of this number.

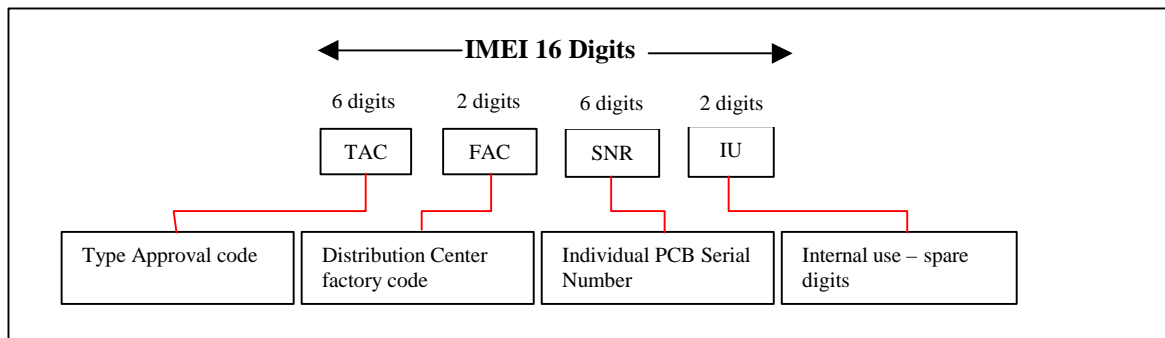

Figure 5.3 IMEI label breakdown

Some other label number configurations that will be present will be: -

XCVR NUMBER: Identifies type of product. i.e. P7382i / P7389i (Usually SWF number)

PACKAGE NUMBER: Determines type of equipment, mode in which it was shipped and language with which it was shipped.

***Due to the shortage of space on the label, the IMEI and MSN barcodes were removed, that is except for the network provider ‘Orange’ where the IMEI barcode is still in place**

SECTION 6: REPAIR AND TEST PROCEDURES

6.1 Repair Introduction

The P7382i / P7389i is divided into 3 main sections when it comes to part replacability: The housings which contains the alert, speaker, mic, the main PCB which contains RF / Logic circuitry and the keypad interface and finally the display module which connects to the main PCB via a elastomer connector. If the RF / Logic board is required to be changed then a full service transceiver should be ordered as there is no replacement PCB available. Also a personality transfer would be necessary.

6.2 Mechanical repairs

Assembly replacement level troubleshooting and repair of the P7382i / P7389i is limited to isolation and replacement of the main mechanical parts only (See Exploded parts diagram and associated parts list p19 & p20)

6.3 Basic Modular Troubleshooting

The troubleshooting information in **Table 2** shows some typical malfunction symptoms, and for the corresponding verification and repair procedures refer to the disassembly instructions located in the disassembly section of this manual. (**Section 4**).

NOTE

Defective Logic/RF assemblies must be replaced with pre-tested, pre-phased assemblies

Repair Chart

Table 2. GSM P7382i / P7389i Cellular Telephone: Troubleshooting and Repair Chart. (Assembly Replacement Level).

SYMPTOM	PROBABLE CAUSE	VERIFICATION AND REMEDY
Personal telephone will not turn on or stay on	a) Battery pack either discharged or defective	Measure battery. If the battery voltage is <4.00 V dc, recharge the battery using the appropriate battery charger. If the battery will not recharge, replace the battery. If battery is not at fault, proceed to b.
	b) Battery connectors open or misaligned.	Visually inspect the battery connectors on both the battery assembly and the portable telephone. Re-align and, if necessary, replace either the Battery or the battery connector assembly. Removing the battery connector assembly has to be done with extreme care to avoid damaging the housings. If battery connectors are not at fault, proceed to c
	c) Logic/RF Board Assembly Defective.	Remove the Logic/RF Assembly. Substitute a known good assembly and temporarily reassemble the unit. Depress the PWR button; if unit turns on and stays on, disconnect the dc power source and reassemble the telephone with the new Logic/RF Board assembly (see personality transfer). Verify that the fault has been cleared. If the fault has not been cleared then proceed to d.
	d) Display circuit failure	Disassemble unit and remove LCD module and insert known good module. Insert Battery and depress PWR button. Ensure unit stays on, if OK reassemble unit in new housing assembly
2. Personal telephone exhibits poor reception and/or erratic operation (such as calls frequently dropping, Weak and/or distorted audio, etc.).	a) Antenna is defective	Check to make sure that the antenna pin is properly connected into the Logic/ RF assembly. If OK, substitute a known good antenna and test in a call. If the fault is still present, proceed to b.
	b) Logic/RF Board Assembly Defective.	Replace Logic/RF Assembly (refer to symptom 1c). Verify that the fault has been cleared and Re-assemble the unit with the new PCB.
3. Display is erratic, or provides Partial or no display.	a) Mating connections to / from LCD Module faulty.	Disassemble unit, check general condition of pads to display. If OK proceed to b.
	b) LCD module is Defective.	Substitute a known good LCD module onto the suspect board and connect to DC Pwr supply. Depress PWR and ensure display is now correct, if Ok rebuild unit with new LCD module if LCD module is not at fault proceed to c.
	c) Logic/RF Board Assembly Defective.	Replace Logic / RF Assembly (refer to symptom 1c). Verify that the fault has been cleared and Re-assemble the unit with the new PCB.

SYMPTOM	PROBABLE CAUSE	VERIFICATION AND REMEDY
<p>4. Incoming call alert transducer audio distorted or volume is too low.</p>	<p>a) Faulty alert Transducer</p>	<p>Remove suspect alert transducer from rear housing and replace with known good alert. If fault does not clear proceed to b)</p>
	<p>b) Main RF / Logic PCB defective</p>	<p>Replace Logic/RF Board Assembly (refer to symptom 1c). Verify that the fault has been cleared and re-assemble the unit with the new PCB.</p>
<p>5. Personal telephone transmit audio is weak, (usually indicated by called parties complaining of difficulty in hearing voice from personal phone).</p>	<p>a) Microphone connections to The main RF / Logic board are defective.</p>	<p>Gain access to the Microphone as described in the DISASSEMBLY instructions in this manual. . Check connections. If connector is faulty proceed to c if the connector is OK, proceed to b.</p>
	<p>b) Microphone defective</p>	<p>Gain access to microphone. Disconnect and substitute a known good Microphone. Place a call and verify as heard by called party. If good, re-assemble portable with new Microphone. If Microphone is not at fault, re-install original Microphone and proceed to c.</p>
	<p>c) Logic/RF Board Assembly defective.</p>	<p>Replace Logic/RF Board Assembly (refer to symptom 1c). Verify that the fault has been cleared and re-assemble the unit with the new PCB.</p>
<p>6. Personal telephone receive audio is weak and/or distorted. (From speaker)</p>	<p>a) Connections to/from speaker and Logic/RF Circuit board defective.</p>	<p>Gain access to Logic/RF board as described in the DISASSEMBLY instructions in this manual. Check pads on the Logic/RF circuit board. Clean pads if necessary. If pad is at fault proceed to d. If connection is not at fault, Proceed to b.</p>
	<p>b) Earpiece Speaker defective.</p>	<p>Remove speaker from front housing and insert known good speaker. Place a call and verify improvement in earpiece audio. If better, reassemble the phone with the good speaker. If it was no better then proceed to c.</p>
	<p>c) Antenna assembly is defective.</p>	<p>Attempt a re-phasing of the unit and recheck the symptom. If symptom is the same but unit re-phases correctly, check to make sure the antenna connector is correctly soldered to the main board and that the antenna is fitted correctly. If ok, substitute a known good antenna assembly. If this does not cure the fault, re-install the original assembly then proceed to d.</p>
	<p>d) Logic/RF Board Assembly Defective.</p>	<p>d) Replace Logic/RF Assembly (refer to symptom 1c). Verify that the fault has been cleared and Re-assemble the unit with the new PCB.</p>
<p>7. Personal telephone will not recognize/accept SIM card</p>	<p>a) SIM card defective</p>	<p>Initially check that the contacts on the card are not dirty. Clean if necessary, and check if fault has been eliminated. If the contacts are clean, insert a Known good SIM card into the portable telephone. Power up the unit and confirm whether or not the card has been accepted. If the fault no longer Exists, the defective SIM card should be replaced. If the SIM card is not at fault, proceed to b.</p>
	<p>b) Logic/RF Board Assembly Defective.</p>	<p>Replace Logic/RF Board Assembly (refer to symptom 1c). Verify that the fault has been cleared and re-assemble the unit with the new PCB.</p>
<p>8. Phone does not sense when flip is Opened or closed (L189 Only) (usually indicated by inability to answer incoming calls by opening the flip, or inability to make outgoing calls).</p>	<p>a) Magnet in flip defective</p>	<p>Replace Front / flip assembly with known good one, refer to the DISASSEMBLY instructions in this manual. Place call to portable phone and verify ability to answer by opening flip. If faulty rebuild phone with new front / flip Assy. If fault is still present, replace original front/flip assembly and proceed to b.</p>

SYMPTOM	PROBABLE CAUSE	VERIFICATION AND REMEDY
	b) Reed Switch defective	Gain access to RF / Logic PCB as described in the DISASSEMBLY instructions in this manual. Unsolder the reed switch and replace with a known good one. Reassemble unit. Place call to portable phone and verify ability to answer by opening flip. If fault still present, replace original reed switch and proceed to c.
9. Internal Charger not working	a) Faulty charger circuit on main Board.	Test a selection of batteries in the rear pocket of the desktop charger. Check LED display for the charging indications. If these are charging ok, then the internal charger is at fault. Replace Logic/RF Board Assembly (refer to symptom 1c). Verify that the Fault has been cleared and re-assembles the unit with the new PCB.
10. No / Weak audio when using headset	a) Headset not fully pushed home	Fully ensure the 'click' is felt on the jack socket. If still at fault proceed to b)
	b) Faulty Jack Socket / Defective PCB	Replace Logic/RF Board Assembly (refer to symptom 1c). Verify that the fault has been cleared and re-assemble the unit with the new PCB.
11. No IrDA Connection	a) Alignment of handset / IrDA device	Ensure unit is no more than 25cm away from the IrDA device that will be talked to, also ensure as good as alignment as possible. If still no connection proceed to b)
	b) Remote Device faulty	Check unit against known good IrDA device to see if connection is made. If fault still present refer to c)
	c) Logic/RF Board Assembly Defective.	Replace Logic/RF Board Assembly (refer to symptom 1c). Verify that the fault has been cleared and re-assembles the unit with the new PCB.

6.4 Software Upgrade

For information on setting up and equipment required for the flashing of software, contact should be made with the local technical support engineer.

Flashing must take place using the Emmi2D box.

6.5 Flexing

For information on setting up and equipment for flexing, contact should be made with the local technical support engineer.

***IrDA does not support flashing or flexing, only Data transfer**

6.6 Testing on HP8922

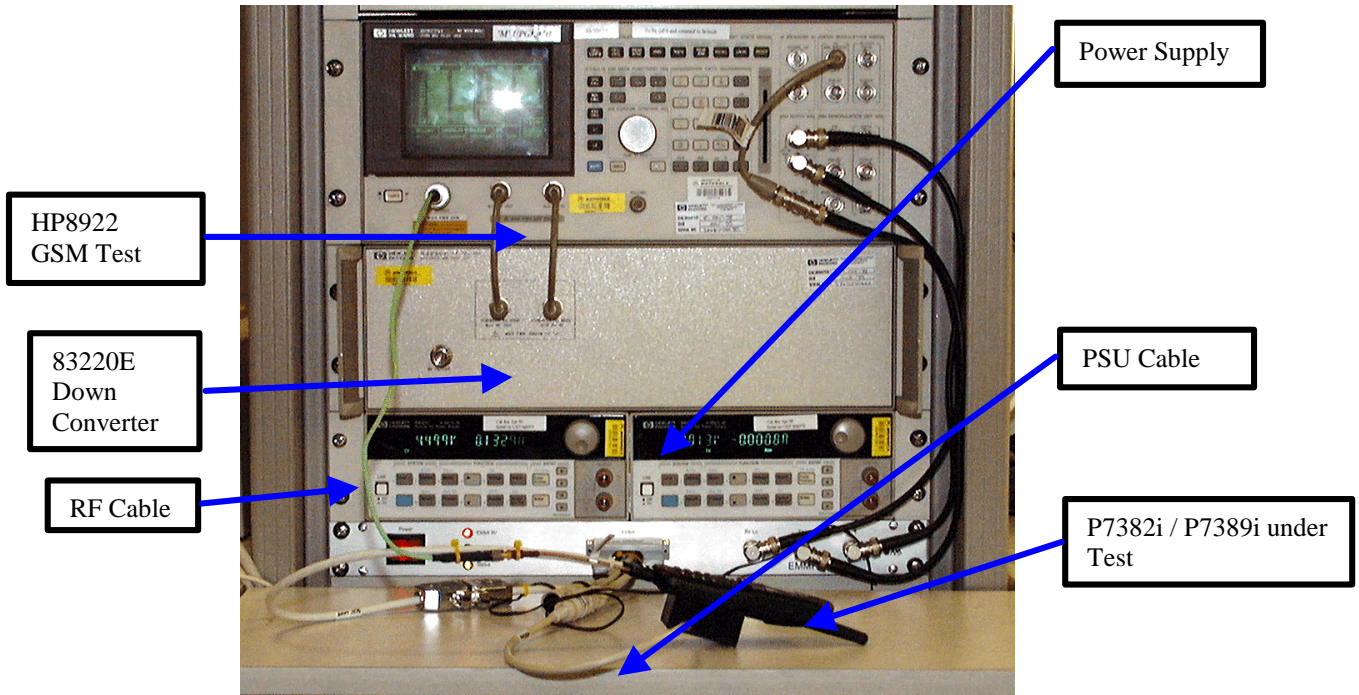

NB* To test the PCB on its own without a housing or SIM card the unit must first be put into test mode and then into Tx or Rx mode using the applicable manual test commands. Ensure that a battery is present during this, as the battery acts as a SIM card presence detect for the unit. The PCB can then be taken out of the housing for any analysis.

6.7 Testing IrDA Port

To test the IrDA port the following set up should be followed, the distance between handset and IrDA port should be less than 30cm and although accurate alignment is not necessary the two should be lined up as well as possible.

Note. Software is required for both the P7382i / P7389i IrDA link and also the host IrDA port. A CD Rom will be shipped with the unit to enable data transfer, the drivers for the host IrDA device should be supplied with the device. For testing all we are looking for is the discovery frame between PC and handset.

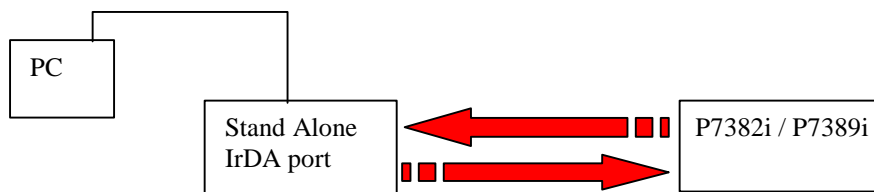

- Please note this set up can only be used for Data Transfer not Flashing or Flexing.
- Also, Windows NT does not have the drivers to support IrDA



6.8 Testing on Go / NoGo tester



The set up for the GO / NOGO tester must be set up as per above. The tester must be set up as per GSM specifications.

The test incorporates the basic live call, during which many of the RF parameters are checked. This test can be ran in 'Autotest' mode, where the radio is classified at the end of the test as a Pass or Fail. This can be used to indicate whether or not a unit is performing to spec through the Butt Plug only.

SECTION 7: ACCESSORIES

7.1 Introduction: The following is a short description of accessories available for the P7382i / P7389i that are currently available, a list of these with corresponding part numbers will follow shortly.

- Half Rate travel charger
 - Included in every package
 - Folding US blades built in
- Mini Rapid Desktop Charger
 - Can charge phone and second battery
 - Sliding door concept reduces size and improves portability
- Headset with Microphone and earpiece (PHFA)
 - Same headset as Zap (SYN6962)
 - No external adapter required
- Mini Pivoting Belt Clip
 - Belt remains on belt
 - Compact and light weight
 - Included in every package
- Leather carry cases
 - leather pouch stylish alternative to the plastic belt clip
- Cigarette Lighter Adapter
 - Same as StarTAC (SYN4241)
- Professional Install Digital Hands-free Car Kit
 - Includes new mini hang up cup
 - Easy one handed insertion
- Data cable (with level translators):
 - Allows full data and fax functionality without PC Card
- Range of Batteries
 - 600 mAh LiIon
 - 1100 mAh LiIon

Additional battery options available in the future

7.2 Mid-rate Charger Information

This is a linear DC supply that plugs into the charger socket of the unit and allows the user to simultaneously make and receive calls. A battery must be inserted for a call to take place. If a battery is completely dead the battery will charge for 30 secs.

Whilst in call the display will show 1 flashing 'Battery Level Bar', this will be re-assessed once the call has ended.

***AA Batteries will not be able to be used, as this will cause damage to the unit through overcharging.**

7.3 Accessory Listing

	Pno	Description	Responsible	Availability	Notes
PWR supplies	SPN4652	Mid rate switch mode charger	WW Accy	Mar-99	w/ US folding plug
Chargers & plugs	SPN4660	Mid rate switch mode charger (China)	WW Accy	Mar-99	w/ US folding plug
	SPN4604	Mini Rae Charger	WW Accy	Done	w/ US folding plug
	SYN7455	UK Plug	WW Accy	Done	
	SYN7456	Euro Plug	WW Accy	Done	
	SYN7457	Aus Plug	WW Accy	Done	
	SYN7458	Indian Plug	WW Accy	Done	
	SYN7460	Korea Plug	WW Accy	Done	
	SPN4608	DT charger (rapid 2-pocket)	Core P7389	At Launch	
	SYN4241	CLA	Done	Done	Compatible w/ ST
Batteries	SNN5517	Li Slim LSQ6 600mAh	Core P7389	At Launch	
	SNN5435	Li Slim LSQ6 530mAh	Core V3688	Done	Compatible w/ V3688
	SNN5451	Li LSQ8	Core V3688	Done	Compatible w/ V3688
Doors	SHN7094	Door Slim Blk	Core P7389	At Launch	Li Poly & LSQ6
	SHN7239	Door Slim Galaxy Grey	Core P7389	At Launch	Li Poly & LSQ6
	SHN7240	Door Slim Sea Blue	Core P7389	At Launch	Li Poly & LSQ6
	SHN7905	Door Large Blk	Core P7389	At Launch	LSQ8 & AAA Std
	SHN7241	Door Large Galaxy Grey	Core P7389	At Launch	LSQ8 & AAA Std
	SHN7242	Door Large Sea Blue	Core P7389	At Launch	LSQ8 & AAA Std
HeadSet	SYN6962	HeadSet w/ mic & earpiece in pouch	Done	Done	Same as V3688
	SYN5195	HATIS device	Done	Done	Same as 8700
Wearability Accy	SHN7175	Belt clip	Core P7389	At Launch	
	SYN7915	Leather case (stays on phone)	Regional	At Launch	
	SYN7914	Leather case (stays on belt)	Regional	At Launch	
Data Accy	SKN4973	Data cadle w/ adapter and level x-lators	Communicate	Feb-99	Same as V3688
	T B D	Smart Collect	Communicate	At Launch	
Car Kits	SYN7916	New HUC Assy	Core P7389	At Launch	
	S8543	DSP prof install	Core P7389	At Launch	
	S8464	DSP easy install HF carkit	WW Accy	Q2-99	HUC not Incl

SECTION 8: GLOSSARY OF TERMS

8.1 List of Abbreviations

Those marked ** are Motorola specific abbreviations.

μBGA	Micro Ball Grid Array
A Interface	Interface between MSC and BSS
A3	Authentication algorithm
A5	Stream cipher algorithm
A8	ciphering key generating algorithm
AB	Access Burst
A-bis	Interface between BSC and BTS
ACCH	Associated Control Channel
ACSE	Association Control Service Element
AGCH	Access Grant Channel
AMPS	Advance Mobile Phone System
AOC	Advice of charge
ARFCN	Absolute Radio Frequency Channel Number
ARQ	Automatic Request for retransmission
ASIC	Application Specific Integrated Circuit
AUC	Authentication Center
AUT (H)	Authentication
BA	BCCH Allocation
BAIC	Barring of All Incoming Calls
BAOC	barring of all Outgoing Calls
BCC	Base Transceiver Station (BTS) Color Code
BCCH	Broadcast Control Channel
BCD	Binary Coded Decimal
BGA	Ball Grid Array
BCU	BTS Control Unit **
Bm	Full-rate traffic channel
BN	Bit Number
BS	Base Station
BSC	Base Station Controller
BSIC	Base Transceiver Station Identity Code
BSS	Base Station System
BSSAP	BSS Application Part (DTAP and BSSMAP)
BSSC	Base Station System Control Cabinet **
BSSMAP	Base Station Systems Management Application Part
BSSOMAP	BSS Operation and Maintenance Application Part
BSU	Base Site Controller Unit **
BTS	Base Transceiver Station
CA	Call Allocation
CBCH	Call Broadcast Channel
cc	Call Control
cc	Country Code
CC	Cellular Cassette
CCBS	Completion of Calls to Busy Subscribers
CCH	Control Channel
CCCH	Common Control Channel
CDMA	Code Division Multiple Access
CFS	Call Forwarding on mobile Subscriber busy
CFU	Call Forwarding Unconditional
CLIP	Calling Line Identification Presentation
CLIR	Calling Line Identification Restriction
CM	Connection Management

P7382i / P7389i

COLP	Connected Line identification Presentation
COLR	Connected Line identification Restriction
CONF	Conference Call add on
CSPDN	Circuit Switched Public Data Network
CUG	Closed User Group
CW	Call Waiting
DB	Dummy Burst
DBS	Distributed Base Station **
DCCH	Dedicated Control Channel
DET	Detach
DFE	Decision Feedback Equalizer
DISC	Disconnect
DL	Data Link (layer)
Dm	Control Channel (ISDN terminology applied to mobile service)
Dm	Signaling channel
Dp	Dialed Pulse
DRCU	Diversity Radio Channel Unit**
DRX	Discontinuous Reception
DTAP	Direct Transfer Application Part
DTE	Data Terminal Equipment
DTMF	Dual Tone Multi-Frequency (tone signaling type)
DTX	Discontinuous Transmission
E	erlang
Eb/No	Energy per Bit/Noise floor
EC	Echo Canceller
Ec/No	Ratio of energy per modulating bit to the noise spectral density
EGSM	Extended Group special Mobile
EFR	Enhanced Full Rate
EIR	Equipment Identity Register
EIRP	Effective Isotropic Radiated Power
EMC	Electromagnetic Compatibility
EMX	Electronic Mobile Exchange **
ETSI	European Telecommunications Standards Institute
FACCH	Fast Associated Control channel
FACCH/F	Full rate Fast Associated Control channel
FACCH/H	Half rate fast Associated Control channel
FB	Frequency correction burst
FCCH	Frequency Correction Channel
FEC	Forward Error Correction
FN	Frame Number
FR	Full Rate
FTAM	File Transfer Access Management
GCC	Global Call Center
GMSC	Gateway Mobile Services Switching Center
GMSK	Gaussian Minimum Shift Keying
GSM	Group Special Mobile
GSM MS	GSM Mobile Station
GSM PLMN	GSM Public Land Mobile Network
HANDO	Handover
HATIS	Hearing Aid Telephone Interconnection System
HDLC	High Level Data Link Control
HLR	Home Location Register
HOLD	Call Hold (Supplementary Service)

P7382i / P7389i

HPLMN	Home PLMN
HPU	Hand Portable Unit
HR	Half Rate
HSN	Hopping Sequence Number
I	Information (frames)
IA5	International Alphanumeric 5
ID	Identification
IMEI	International Mobile Equipment Identity
IMM	Immediate assignment message
IMSI	International Mobile Subscriber Identity
IN	Intelligent Network
INDY	Iridium 9500 handset
IrDA	Infra Red Data Association
ISC	International Switching Center
ISU	Iridium Subscriber Unit
ISDN	Integrated Services Digital Network
ISUP	ISDN User Part
IWF	Interworking Function
Kc	ciphering Key
Ki	Individual subscriber authentication key
LAC	Location Area Code
LAI	Location Area Identification (Identity)
LAPB	Link Access Procedure 'B' (balanced) channel
LAPDm	Link Access Procedure 'DM' (mobile 'D') channel
Lm	Traffic channel (with capacity lower than Bm)
LPC	Linear Predictive Code
LR	Location Register
MA	Mobile Allocation
MAH	Mobile Access Hunting
MAI	Mobile Allocation Index
MAIO	Mobile Allocation Index Offset
MAP	Mobile Application Part
MCC	Mobile Country Code
MCI	Malicious Call Identification
MD	Mediation Device
ME	Mobile Equipment
MF	Multi-Frequency (tone signaling type)
MLSE	Maximum Likelihood Sequence Estimator
MM	Mobility Management
MMI	Man Machine Interface
MNC	Mobile Network Code
MO	Mobile Originated
MO/PP	Mobile Originated Point to Point messages
MoU	Memorandum of Understanding
MRN	Mobile Roaming Number
MS	Mobile Station
MSC	Mobile Services Switching Center
MSCM	Mobile Station Class Mark
MSIN	Mobile Station Identification Number
MSISDN	Mobile Station international ISDN number
MSRN	Mobile Station Roaming Number
MT	Mobile Termination
MTP	Message Transfer Part
MT/PP	Mobile Terminated Point to Point messages

P7382i / P7389i

NAMPS	North American-Advance Mobile Phone System
NB	Normal Burst
NE	Network Elements
NET	Norme European de Telecommunications
NM	Network Management
NHC	Network Management Center
O&M	Operations and Maintenance
OACSU	Off Air Call Set-Up
OCB	Outgoing Calls Barred
OMAP	Operations and Maintenance Application Part (previously was OAMP)
OMC	Operations and Maintenance Center
OMCR	Operations and Maintenance Center -Radio Part
OMCS	Operations and Maintenance Center -Switch Part
OSI	Open System Interconnection
PAD	Packet Assembly Disassembly facility
PCH	Paging Channel
PDN	Public Data Networks
PIN	Personal Identification Number
PLMN	Public Land Mobile Network
POTS	Plain Old Telephone Service (basic telephone services)
PSPDN	Public Switched Packet Data Network
PSTN	Public Switched Telephone
PTO	Public Telecommunications Operator
QOS	Quality of Service
RAB	Random Access Burst
RACH	Random Access Channel
RBDS	Remote BSS Diagnostic Subsystem **
RBUS	Remote Base Station Unit (PCN) **
RCU	Radio Channel Unit **
REC	Recommendation
REL	Release
RELPLTP	Regular Pulse Excitation - Long Term Prediction
REQ	Request
RFCH	Radio Frequency Channel
RFN	Reduced TDMA Frame Number
RLP	Radio Link Protocol
ROSE	Remote Operations Service Element (a CCITT specification for O&M)
RXCDR	Remote Transcoder Unit **
RXLEV	Received signal level
RXQUAL	Received signal quality
SABM	Set Asynchronous Balance Model
SACCH	Slow Associated Control Channel
SAPI	Service Access Point Indicator (Identifier)
SB	Synchronization Burst
SC	Service Center
SCCP	Signaling Connection Control Part
SCH	Synchronization Channel
SCP	Service Control Point - an intelligent network entity
SDCCH	Stand-alone Dedicated Control Channel
SDL	Specification Description Language
SFH	Slow Frequency Hopping
SIM	Subscriber Identity Module
SMS	Short Message Service

P7382i / P7389i

SMSCB	Short Message Service Call Broadcast
SND	SeND
SP	Signaling Point
SRES	Signed RESponse (authentication)
SS	Supplementary Service
SS	System Simulator
STP	Signaling Transfer Point
SYSGEN	SYStem GENeration
TA	Terminal Adapter
TA	Timing Advance
TCAP	Transaction Capabilities Application Part
TCH	Traffic Channel
TCH/F	A full rate TCH
TCH/FS	A full rate speech TCH
TCH/HS	A half rate speech TCH
TCP	Transmission Control Protocol
TDMA	Time Division Multiple Access
TE	Terminal Equipment
TMN	Telecommunications Management Network
TMSI	Temporary Mobile Subscriber Identity
TN	Timeslot Number
TRX	Transceivers
TTY	TeleTYpe (refers to any terminal)
TS	Time Slot
TUP	Telephone Users Part
UI	Unnumbered Information frame
Um	Air Interface
USSD	Unstructured Supplementary Services Data
VAD	Voice Activity Detection
VLR	Visited Location Register
VLSI	Very Large Scale Integration (IC)
VPLMN	Visited PLMN
XC	Transcoder
XCDR	Transcoder **
3PTY	Three party service

P7382i / P7389i- RF SCHEMATICS

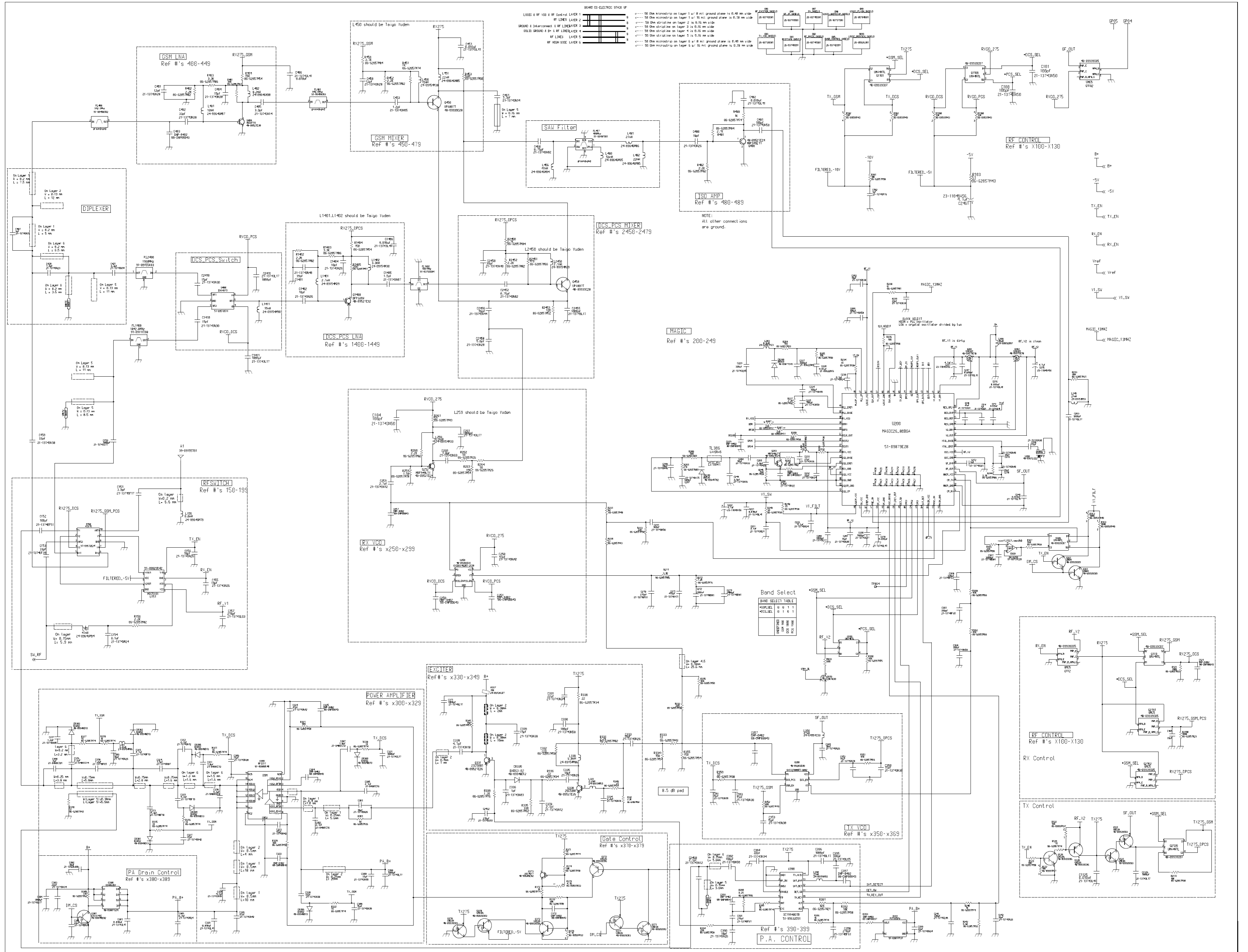

P7382i / P7389i - AL SCHEMATICS

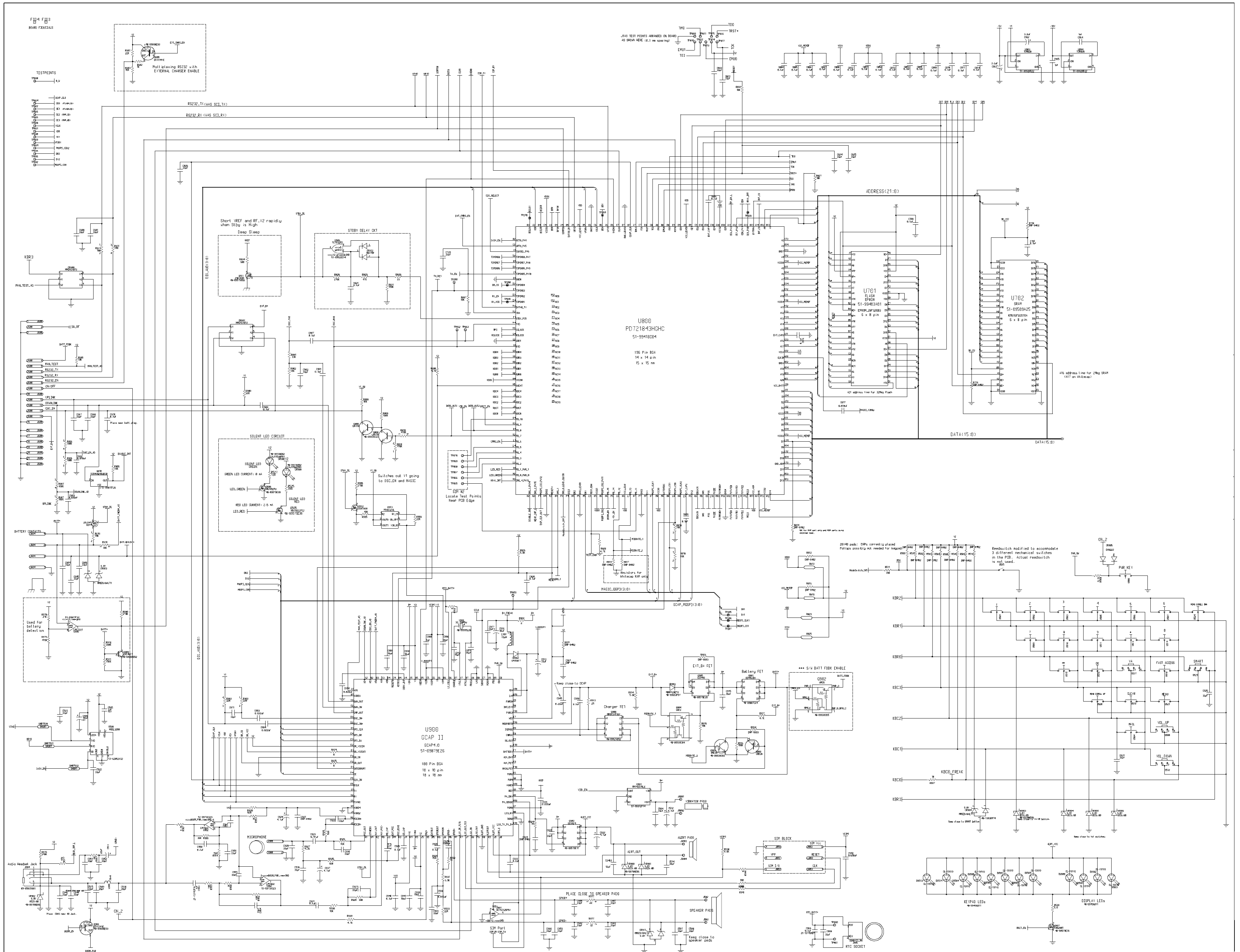

P7382i / P7389i - BLOCK DIAGRAM - PAGE 1/2

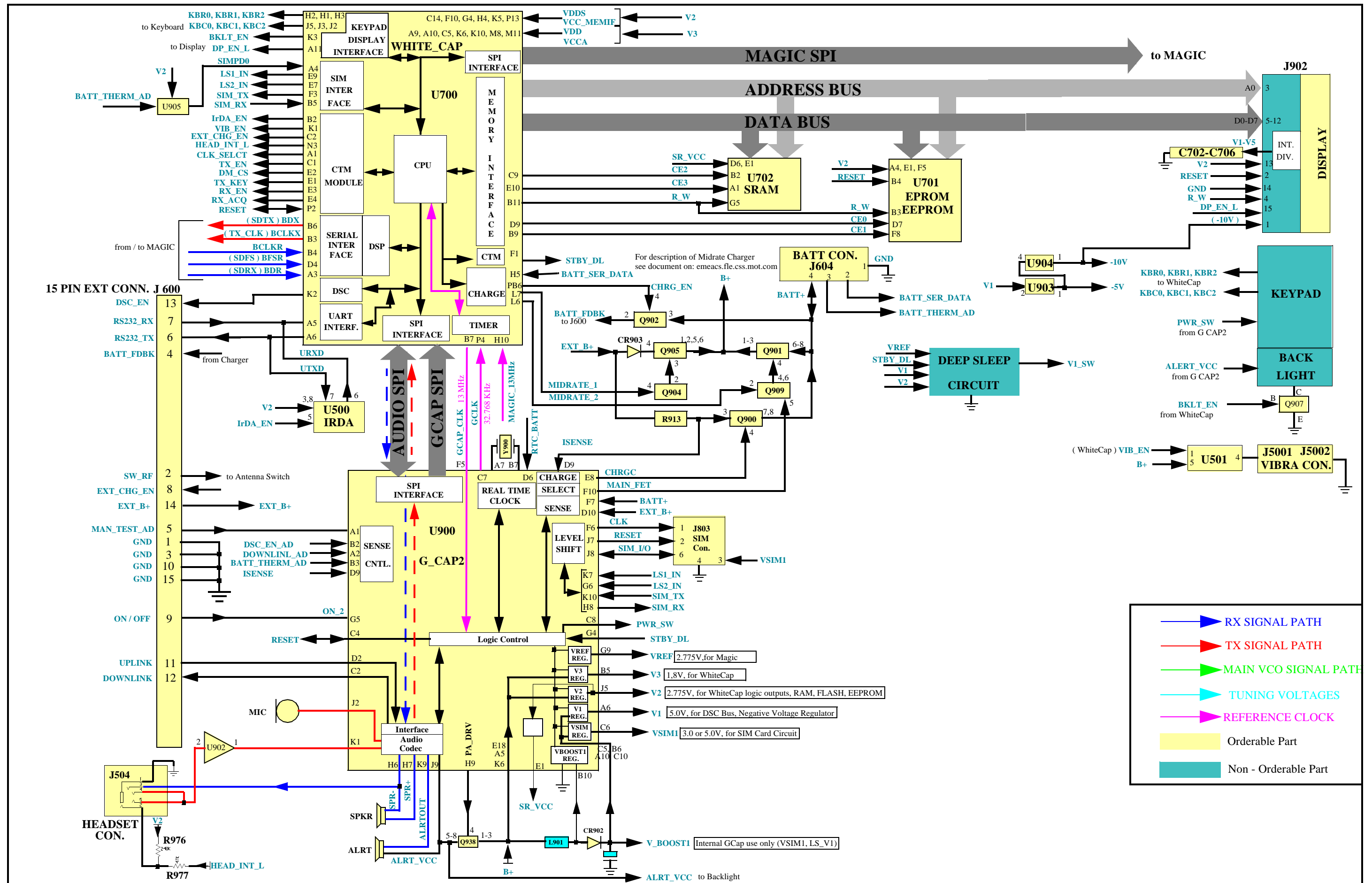

P7382i / P7389i - BLOCK DIAGRAM - PAGE 2/2

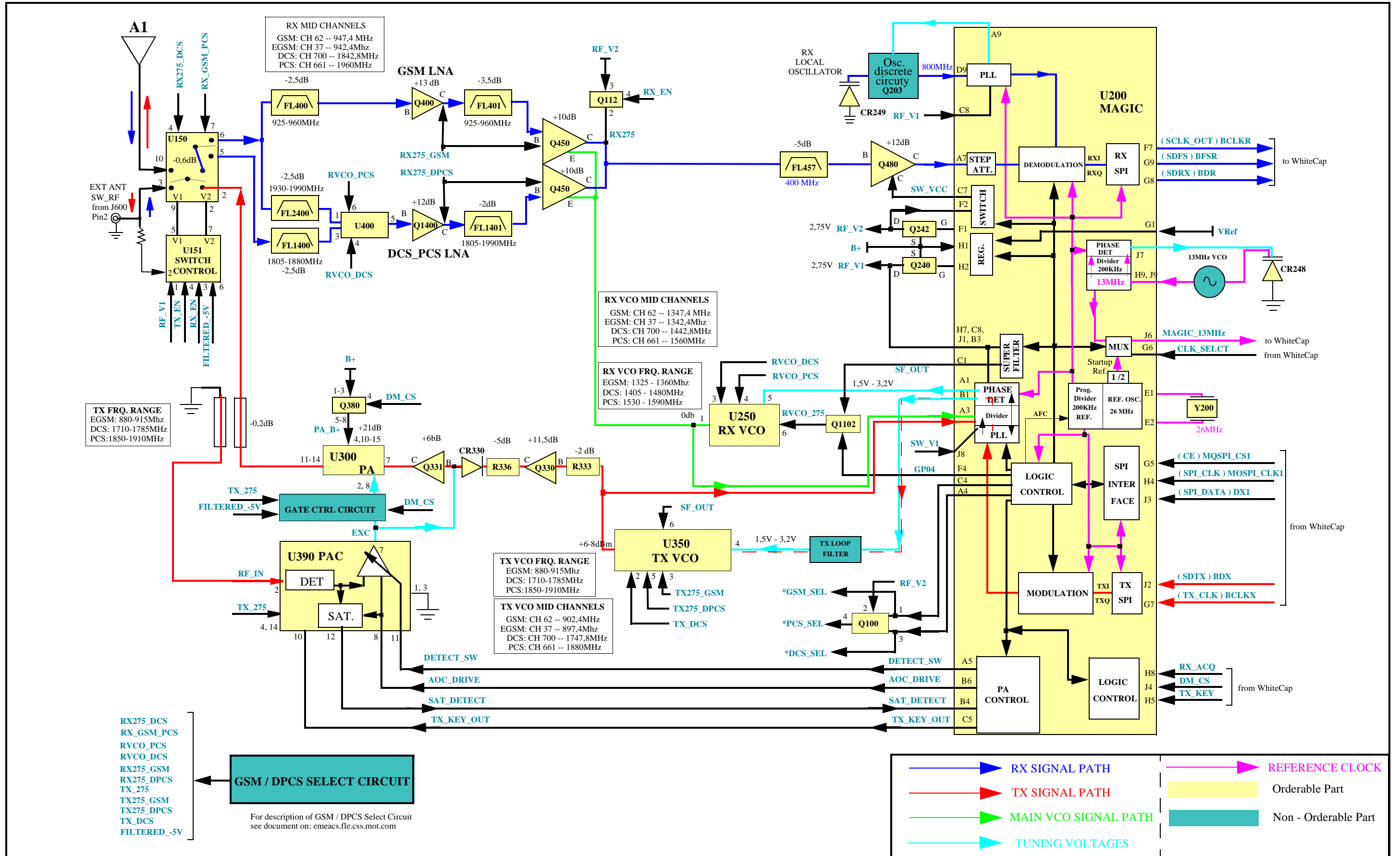

P7382i / P7389i - BOARD LAYOUT - PAGE 1/2

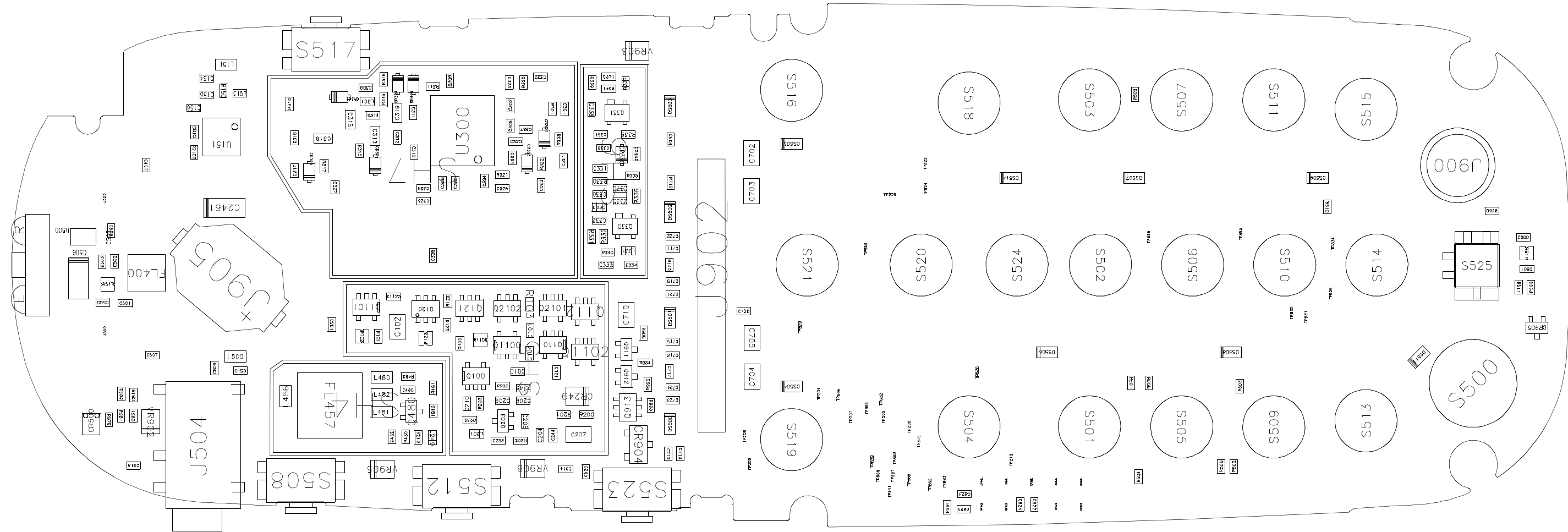

P7382i / P7389i - BOARD LAYOUT - PAGE 2/2

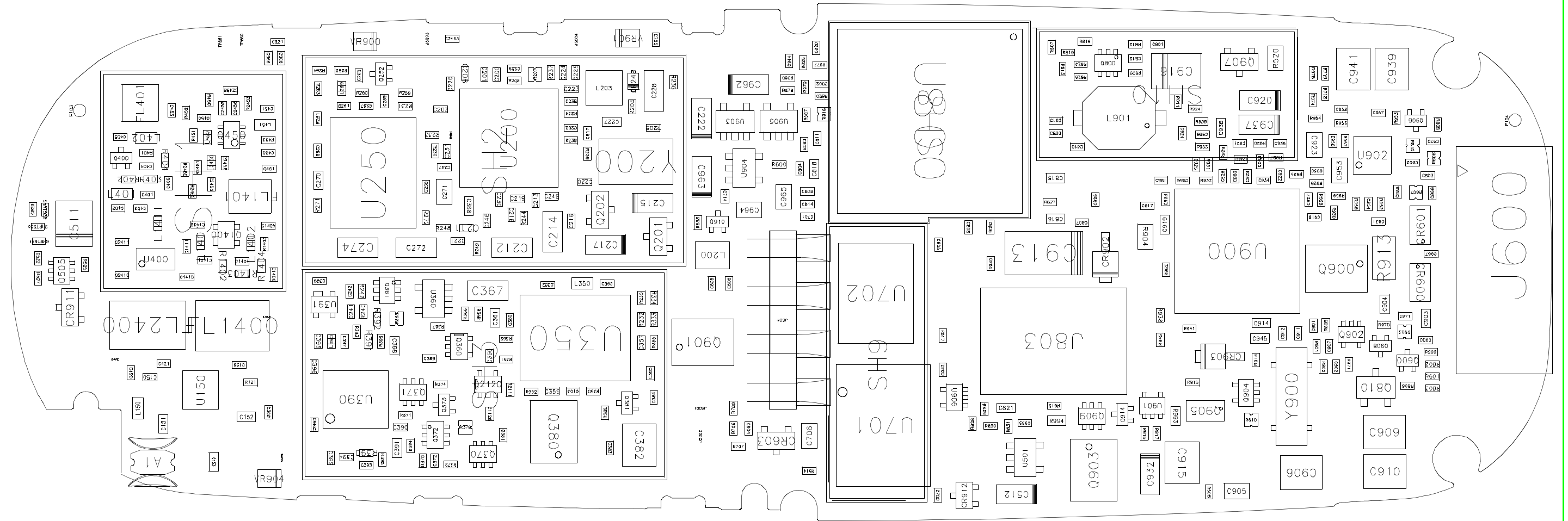

P7382i / P7389i - SIGNAL FLOW

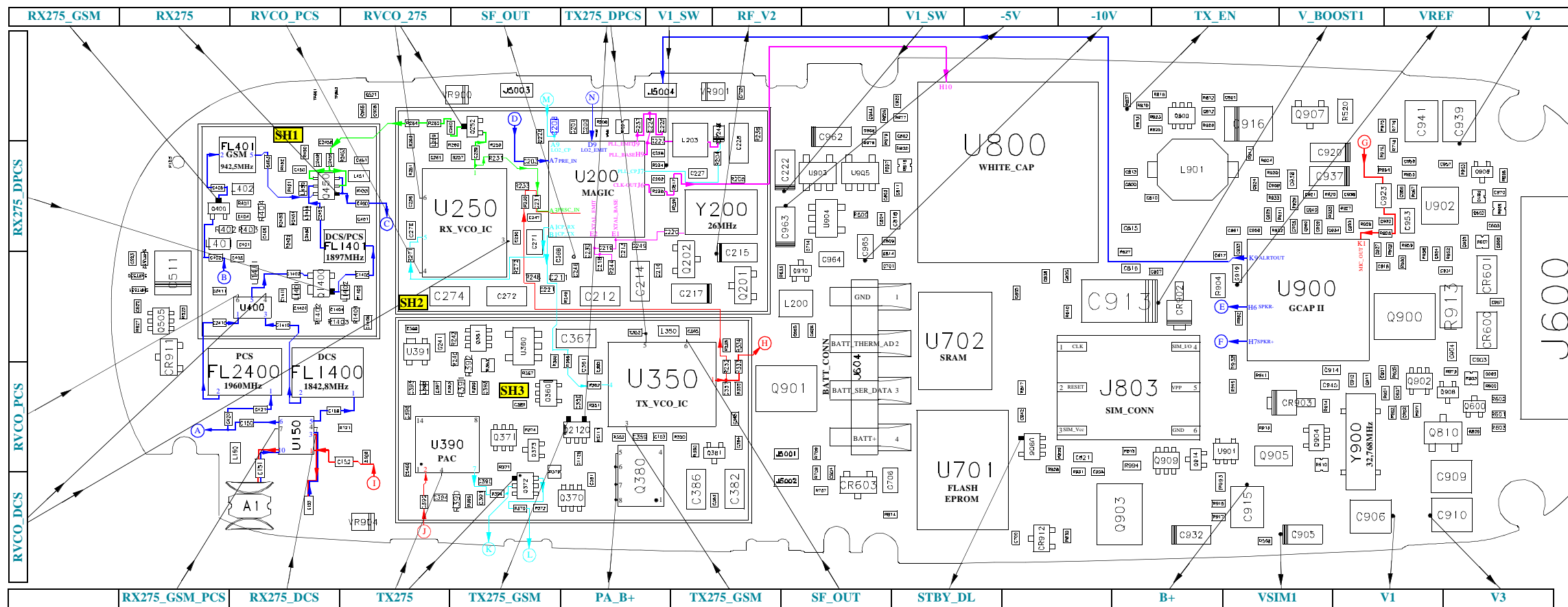

J600	EXT CONN
1	NC
2	SW_RF
3	GND
4	BATT_FDBK
5	MAN_TEST_AD
6	RS232_TX
7	RS232_RX
8	RX_CHRG_EN
9	ON_2
10	GND
11	UPLINK
12	DOWNLINK
13	DSC_EN
14	EXT_B+
15	GND

J902	DISPLAY CONN
1	/CS1
2	/RES
3	Data/Command
4	R_W
5	D0
6	D1
7	D2
8	D3
9	D4
10	D5
11	D6
12	D7
13	Vop
14	VSS
15	VOUT
16	V1
17	V2
18	V3
19	V4
20	V5
21	VR+
22	IRS*
23	NC
24	NC
25	NC
26	NC
27	NC

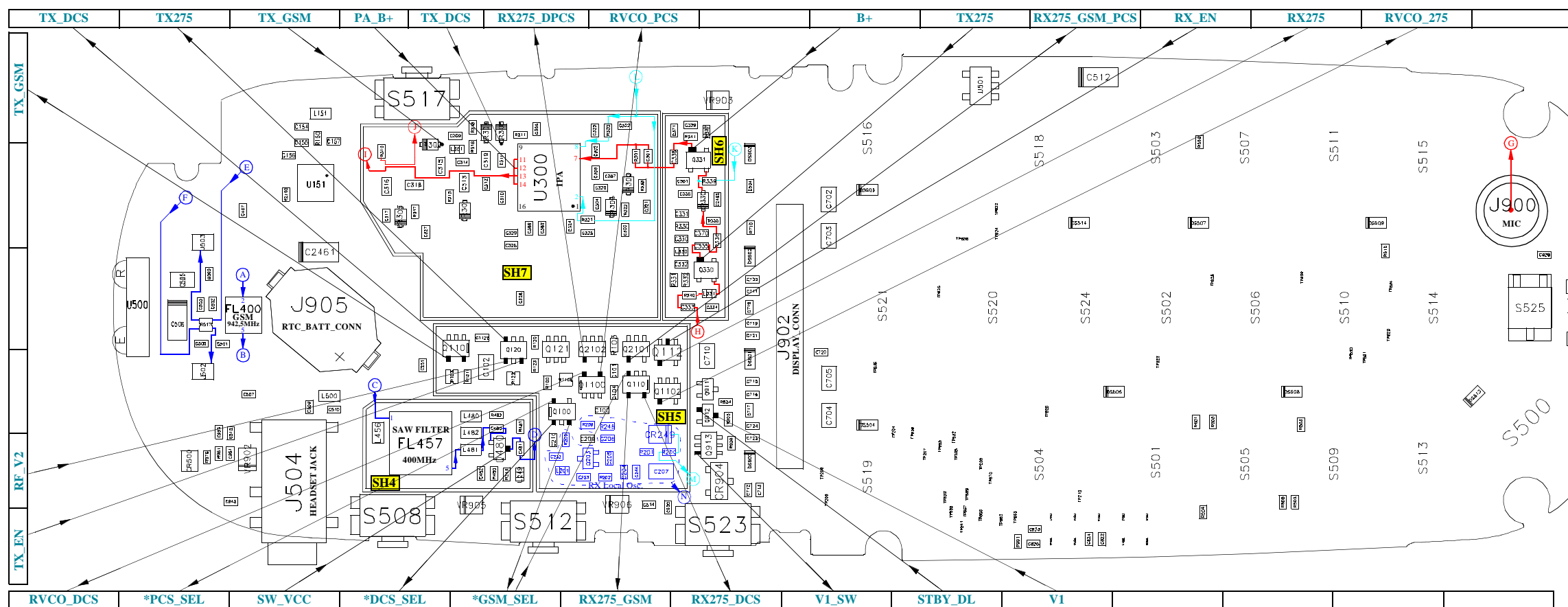

(A)	GSM RX ANTENNA SIGNAL
(B)	FILTERED GSM RX ANTENNA SIGNAL
(C)	UNFILTERED IF 400MHz
(D)	AMPLIFIED IF 400MHz
(E)	RX SPEAKER LINE -
(F)	RX SPEAKER LINE +
(G)	TX MIC LINE +
(H)	TX VCO SIGNAL
(I)	FILTERED PA OUTPUT SIGNAL
(J)	PA DETECT LINE
(K)	PA TUNING VOLTAGE
(L)	PA TUNING VOLTAGE
(M)	RX LOCAL OSC TUNING VOLTAGE
(N)	RX LOCAL OSC 800MHz

P7382i / P7389i - CONNECTOR SCHEMATICS

