

Z8 8403591D06 -P09

Service Engineering & Optimization
Level 3 Authorized

Service, Engineering & Optimization	2007.02.28
Level 3 Schematics	Rev. 1.0
Espoo	8403591D06_P9
	Page 1 of 13

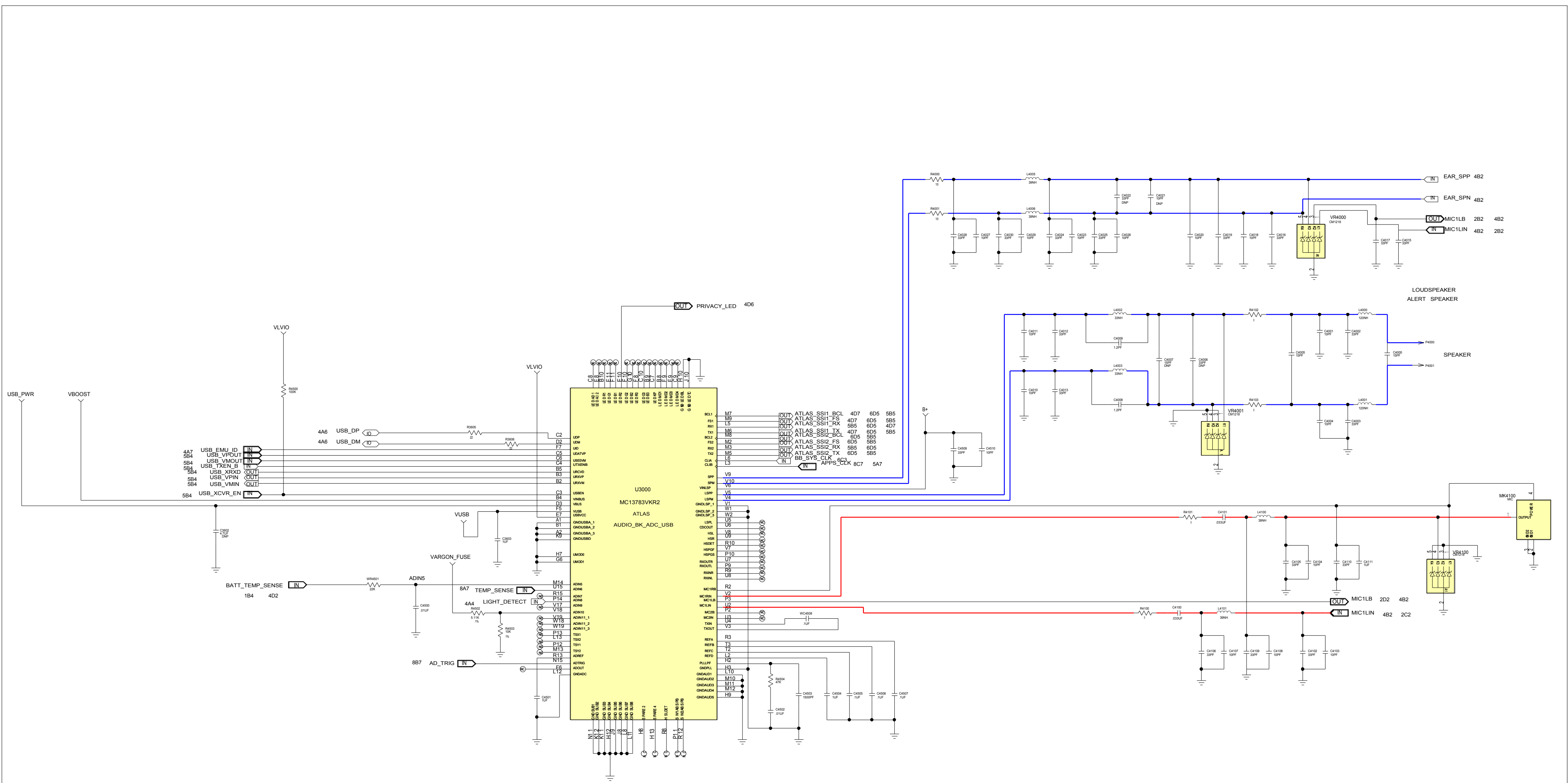

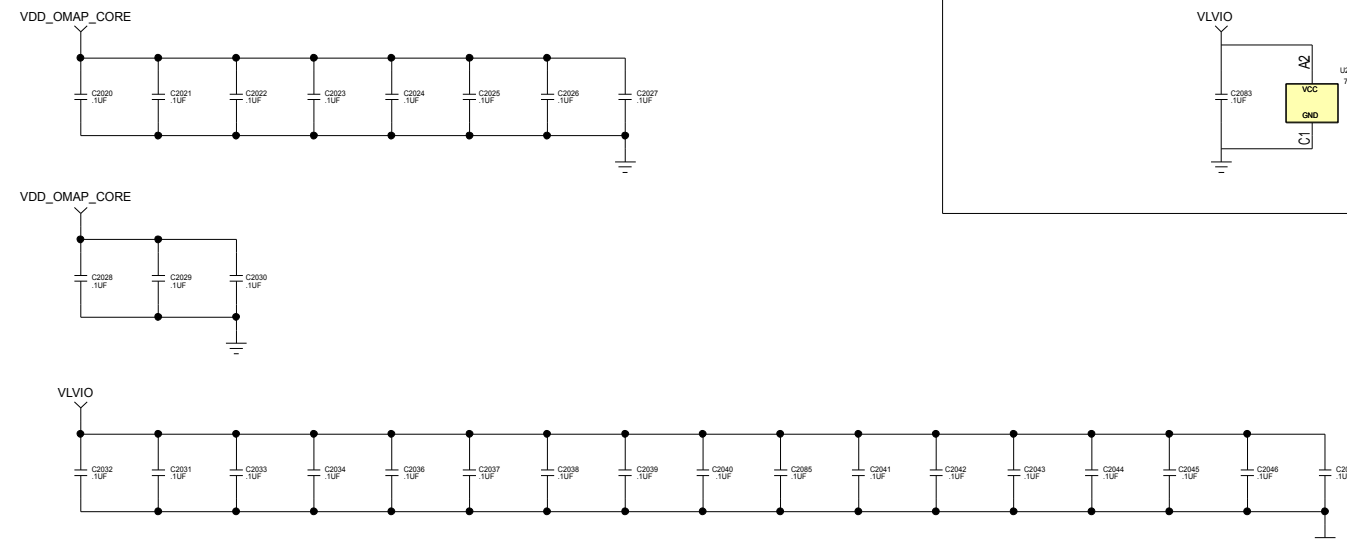
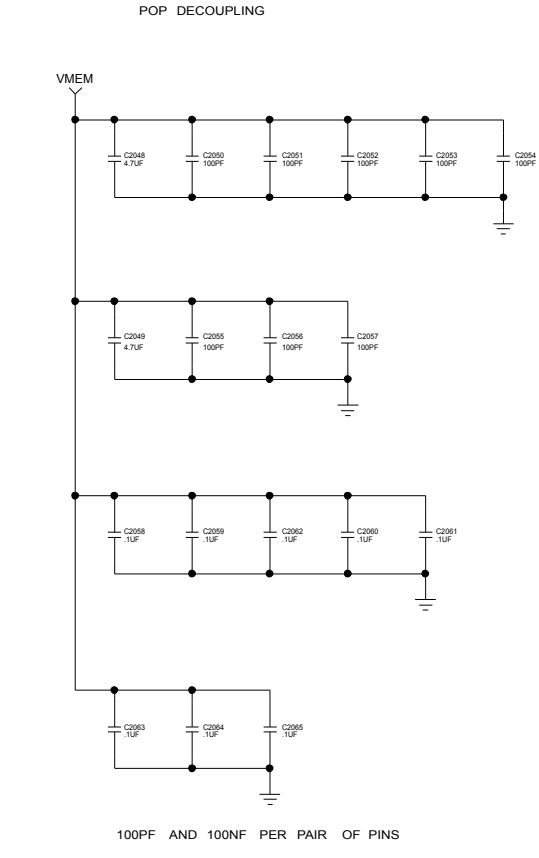
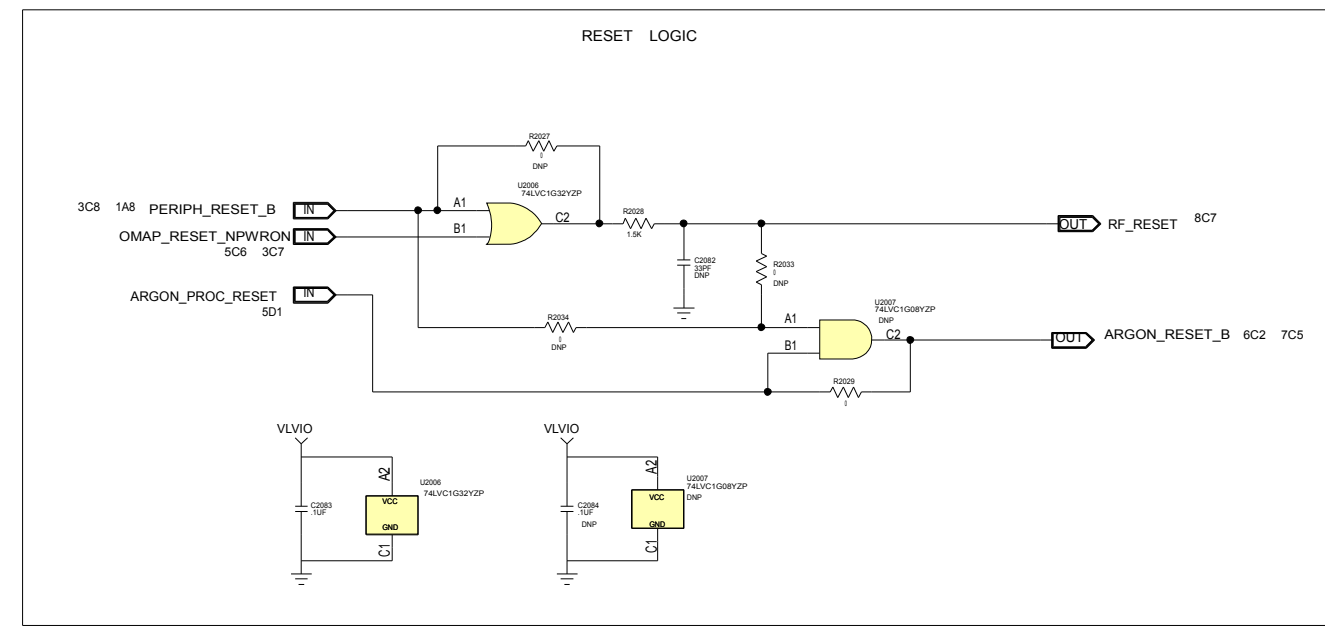
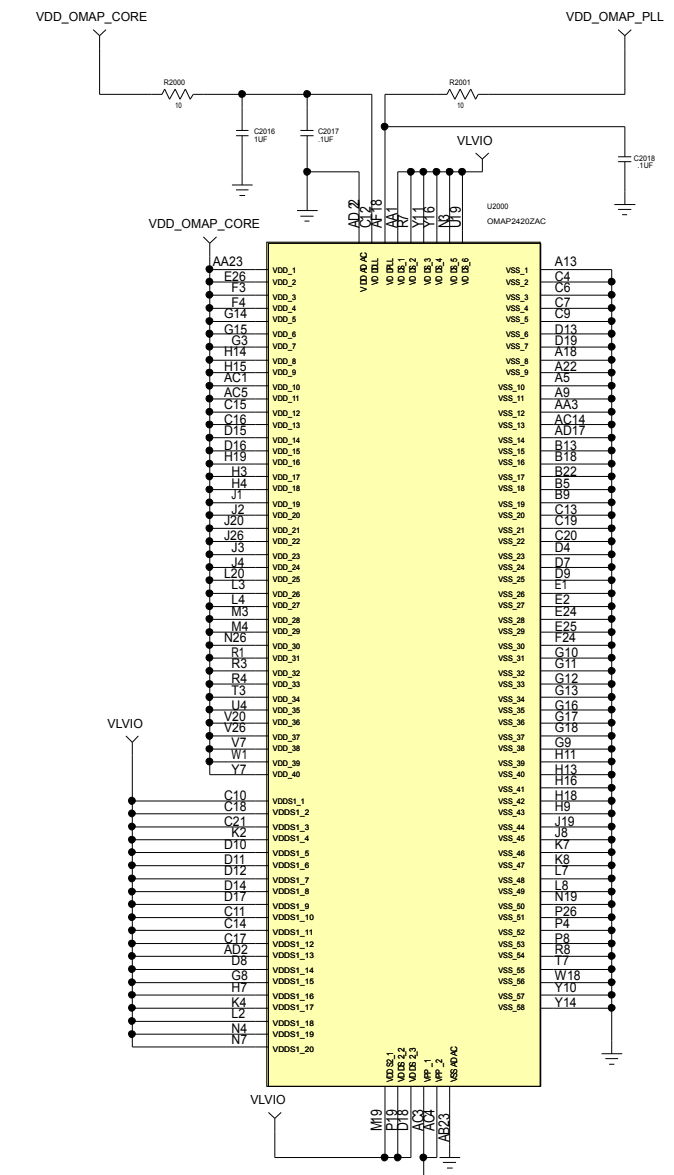
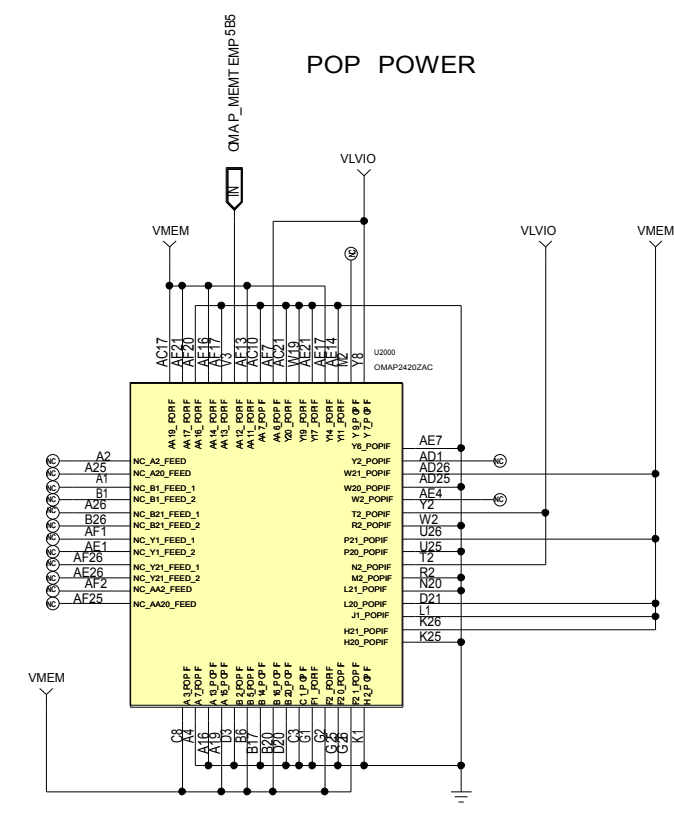
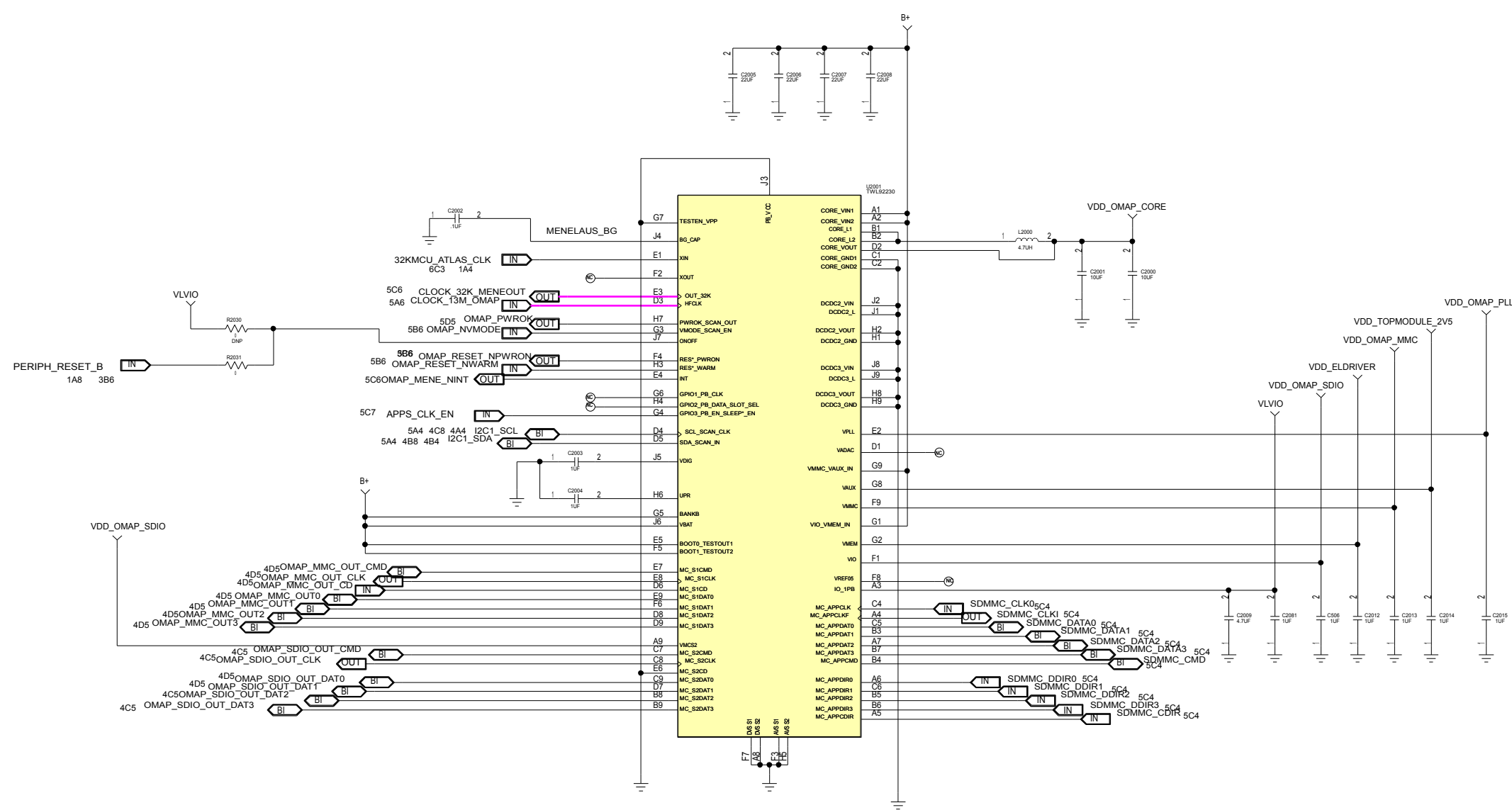

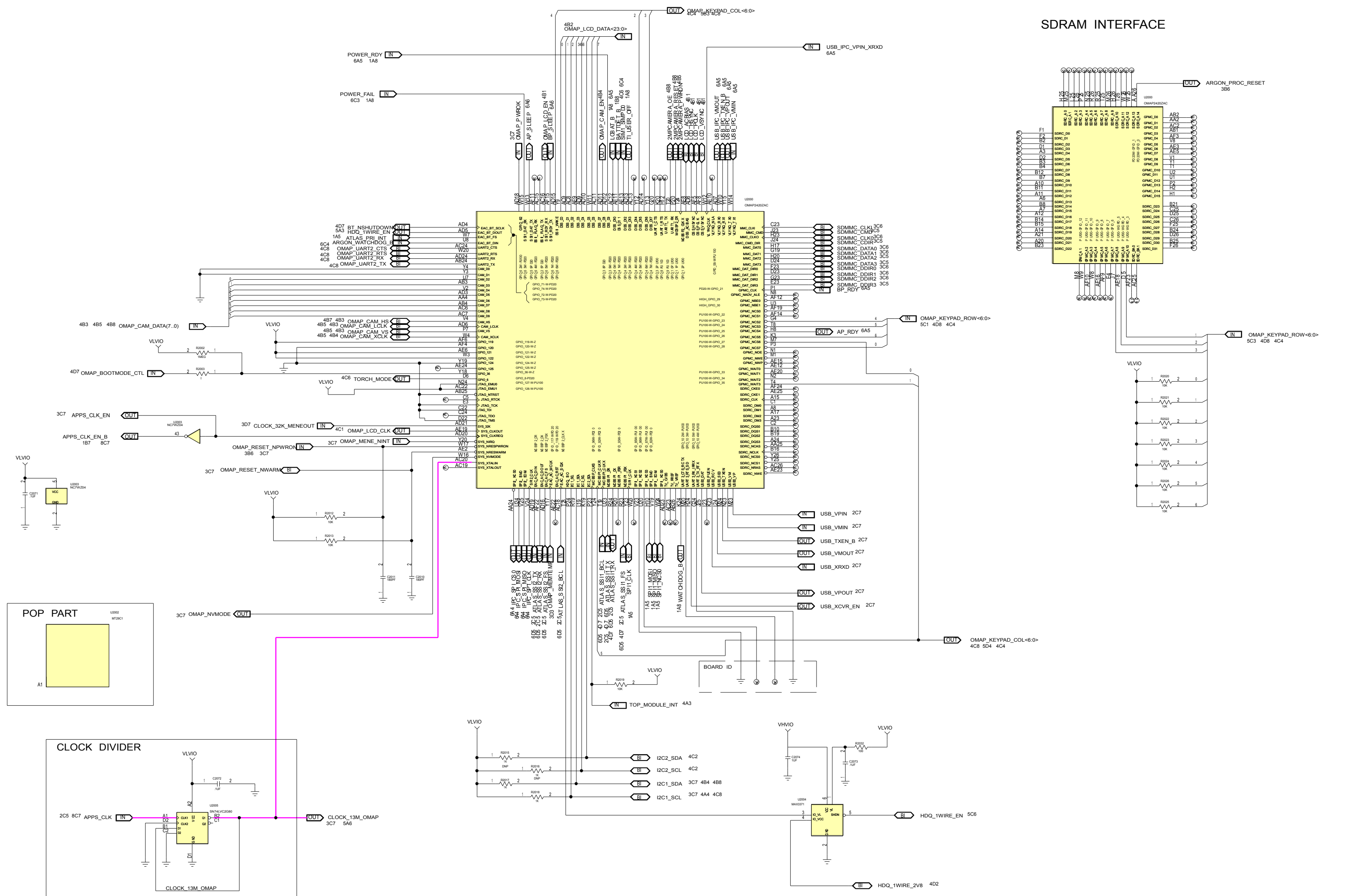

SDRAM INTERFACE

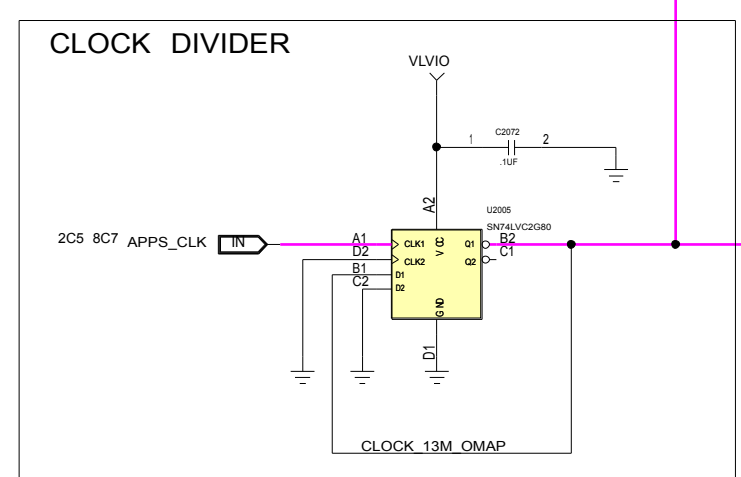
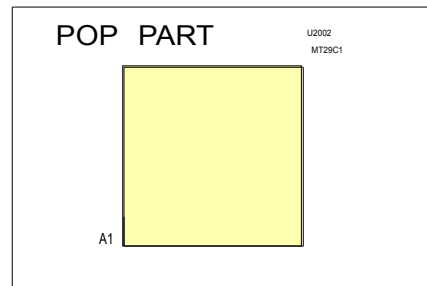
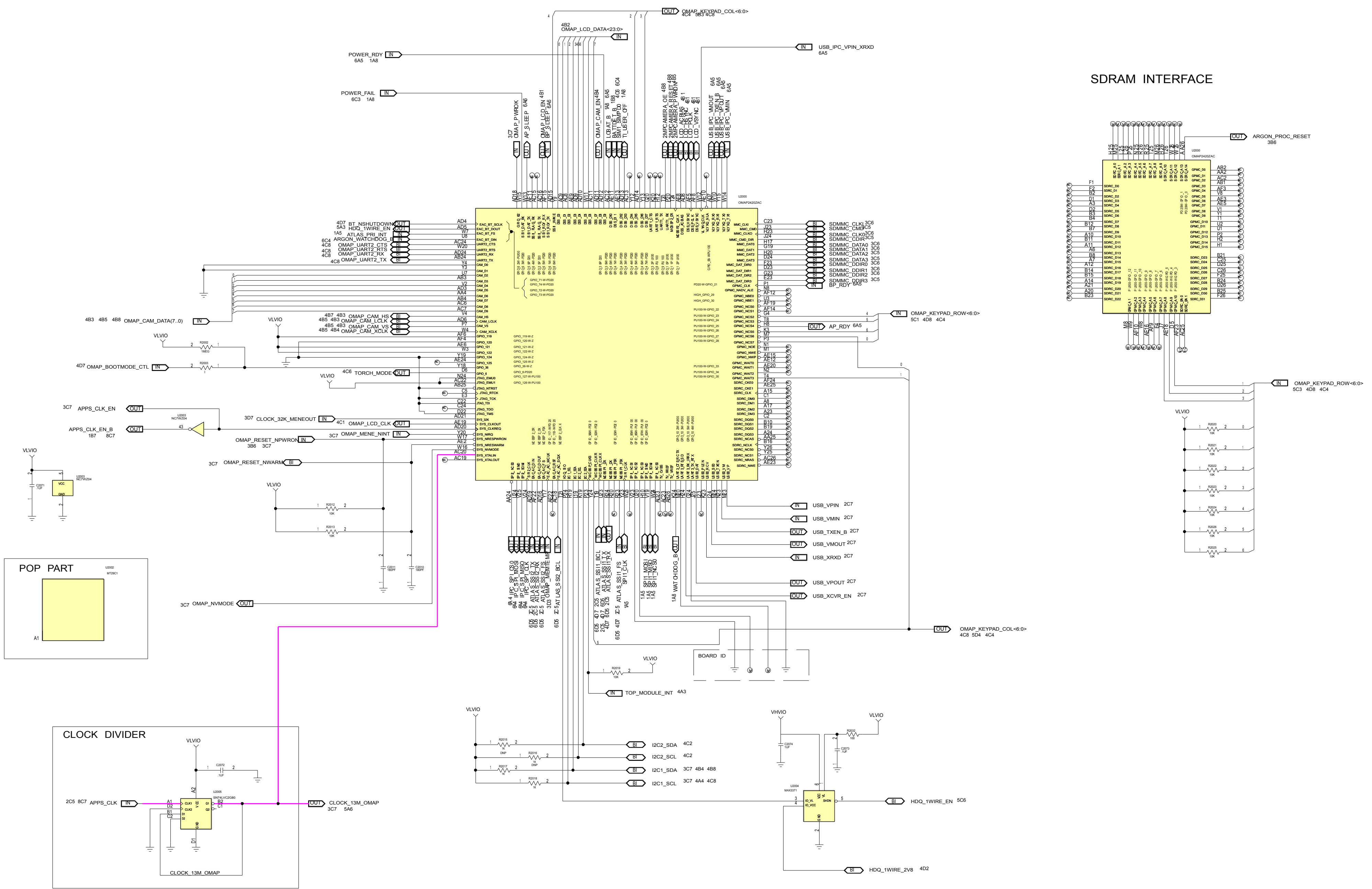
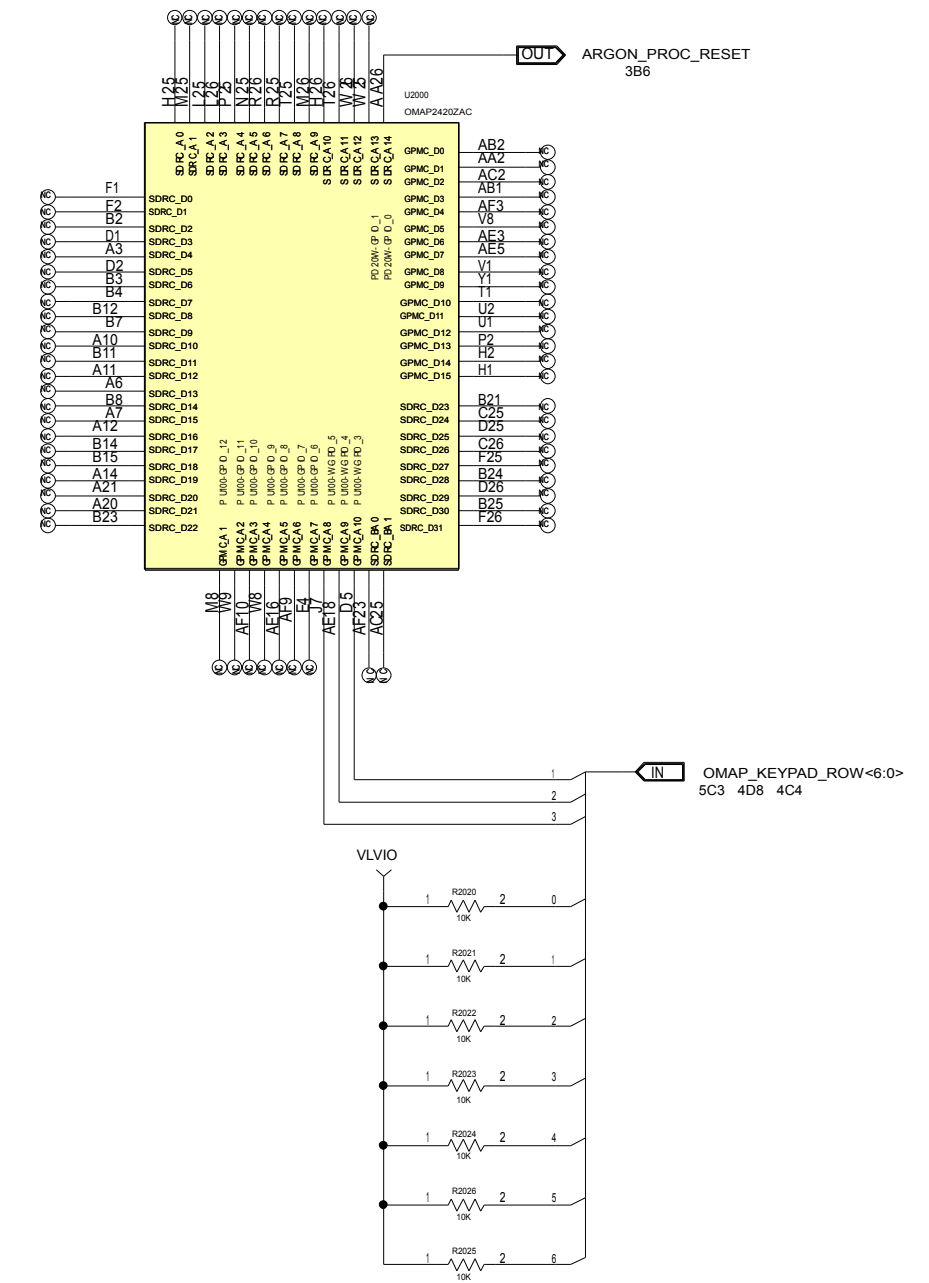

EXPANSION BOARD

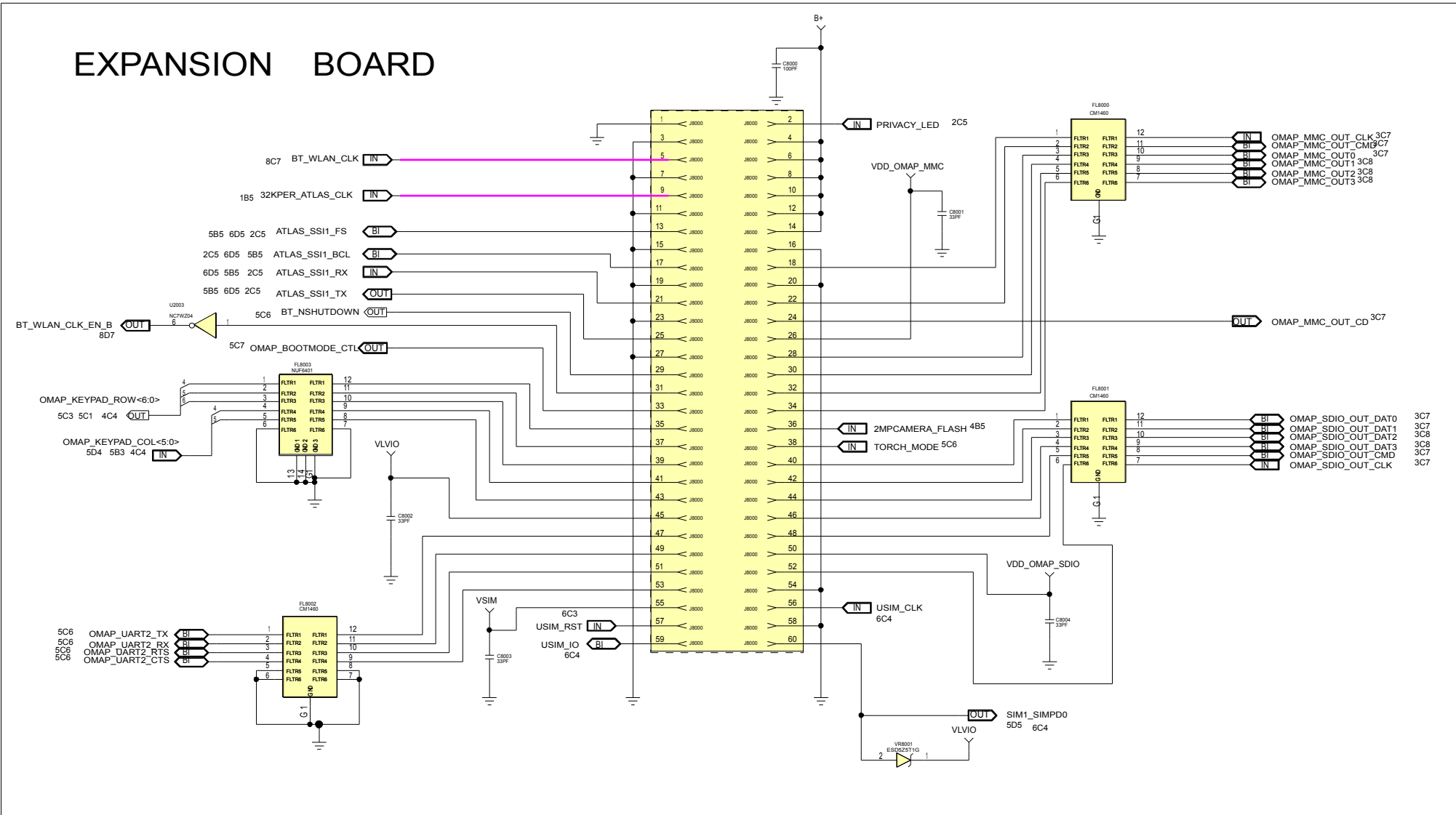

MAIN KEYPAD

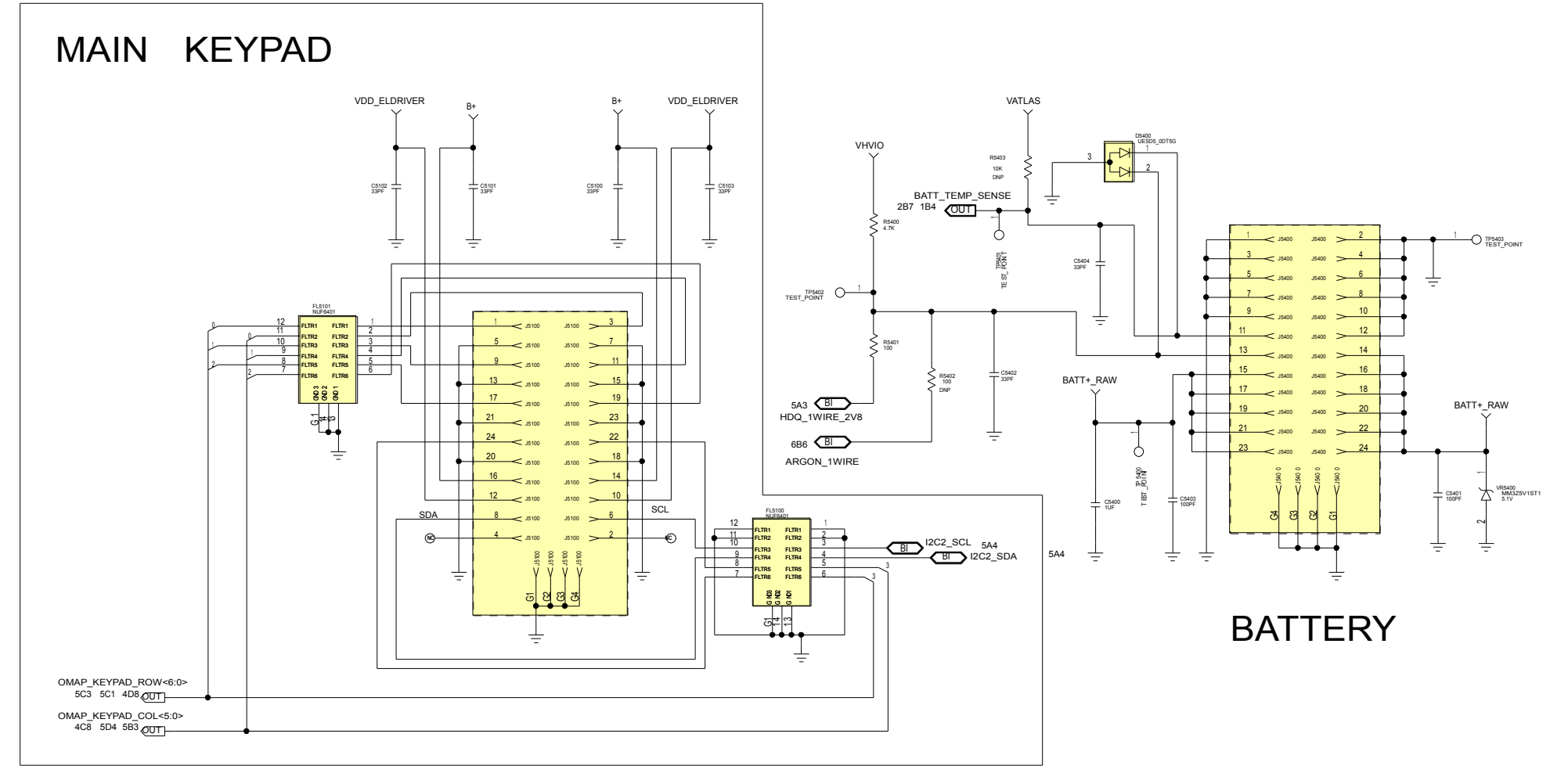

BATTERY

CAMERA

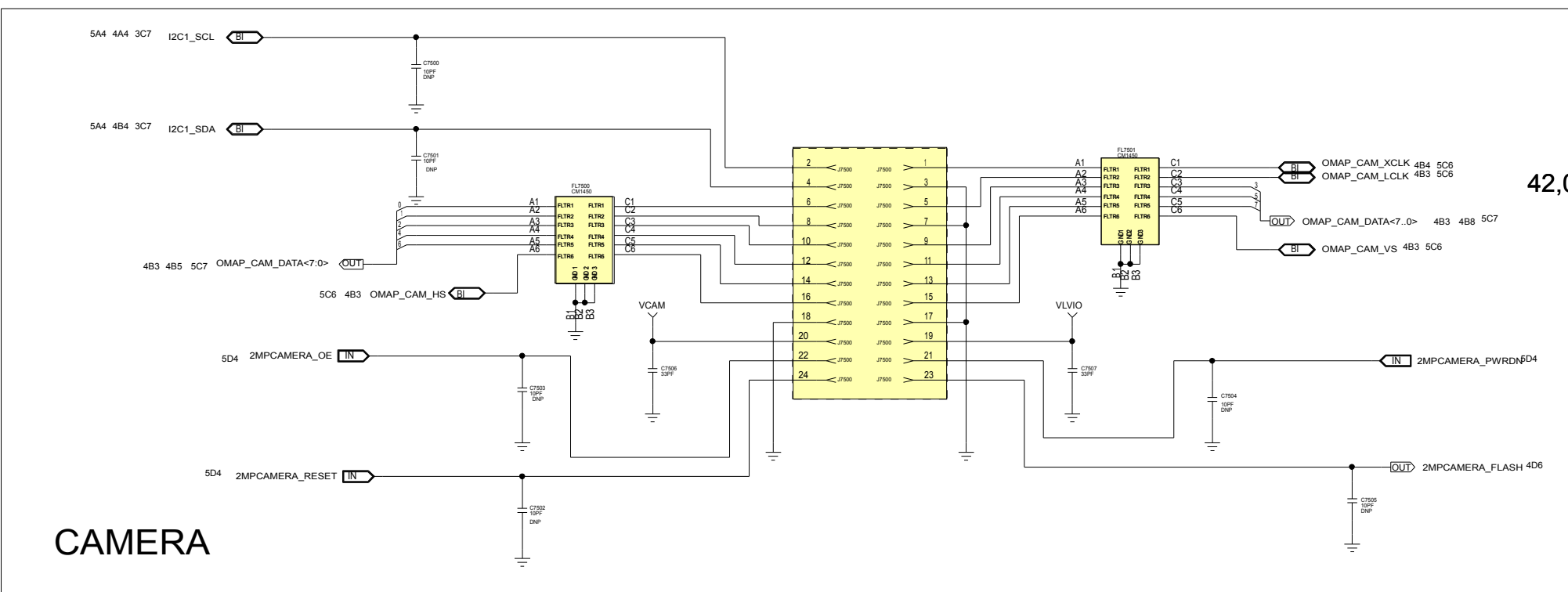

42.0

EMU CONNECTOR

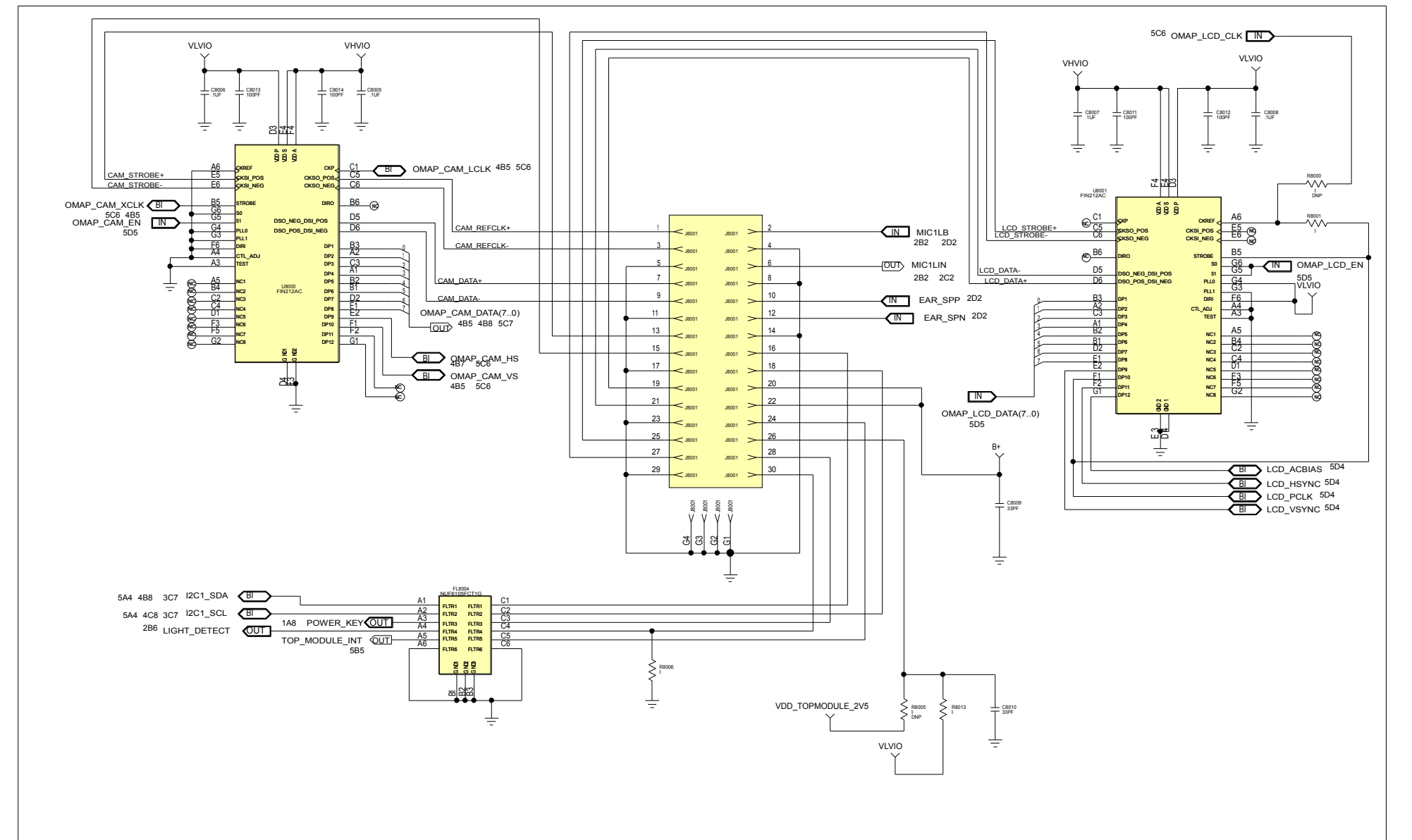
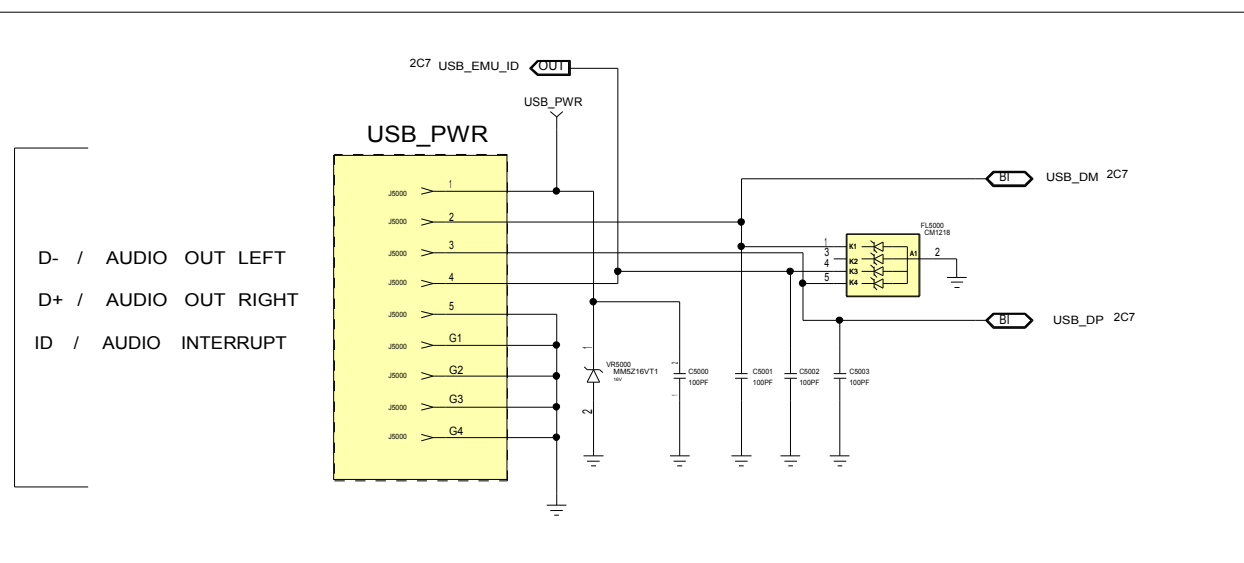

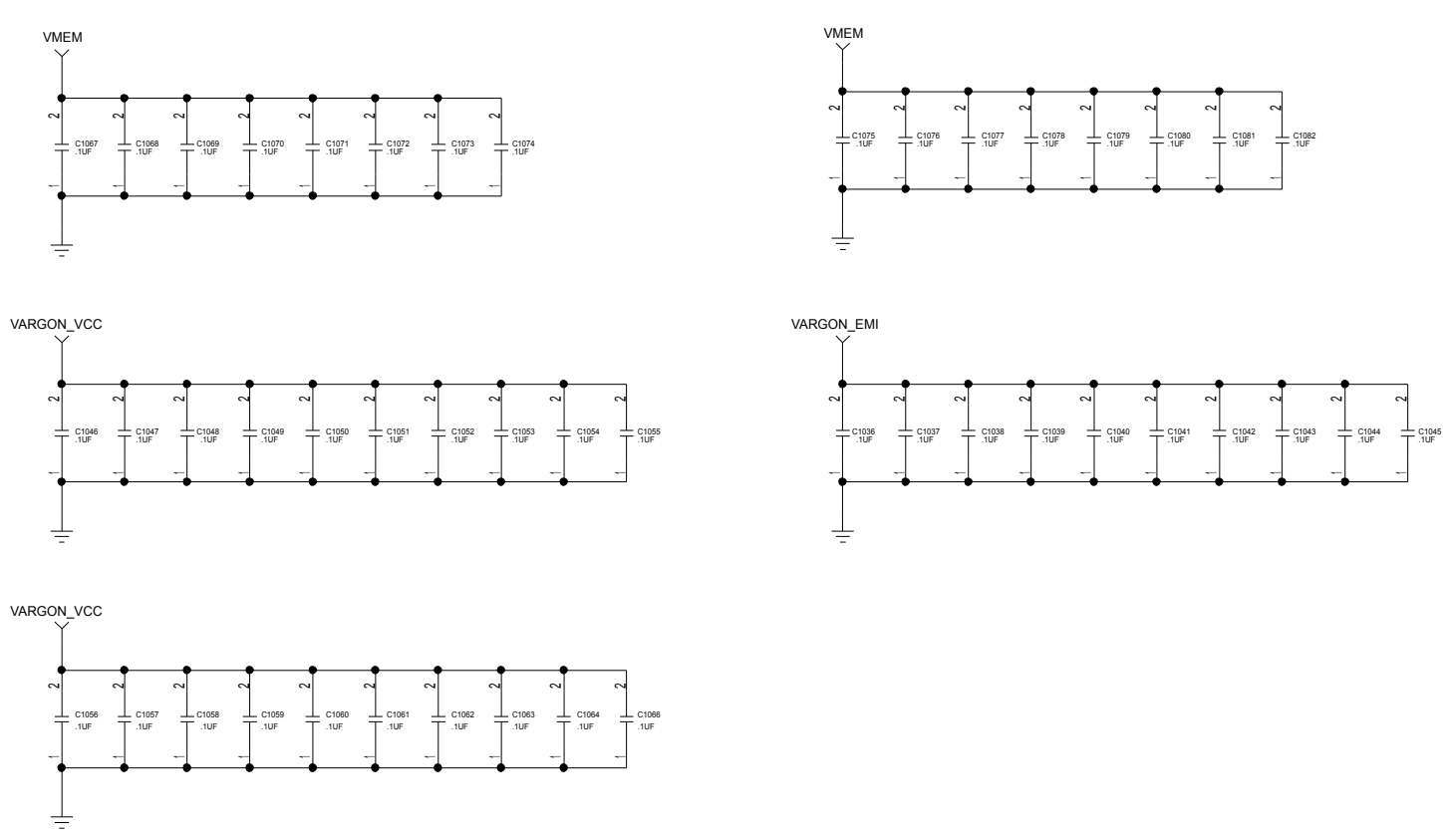
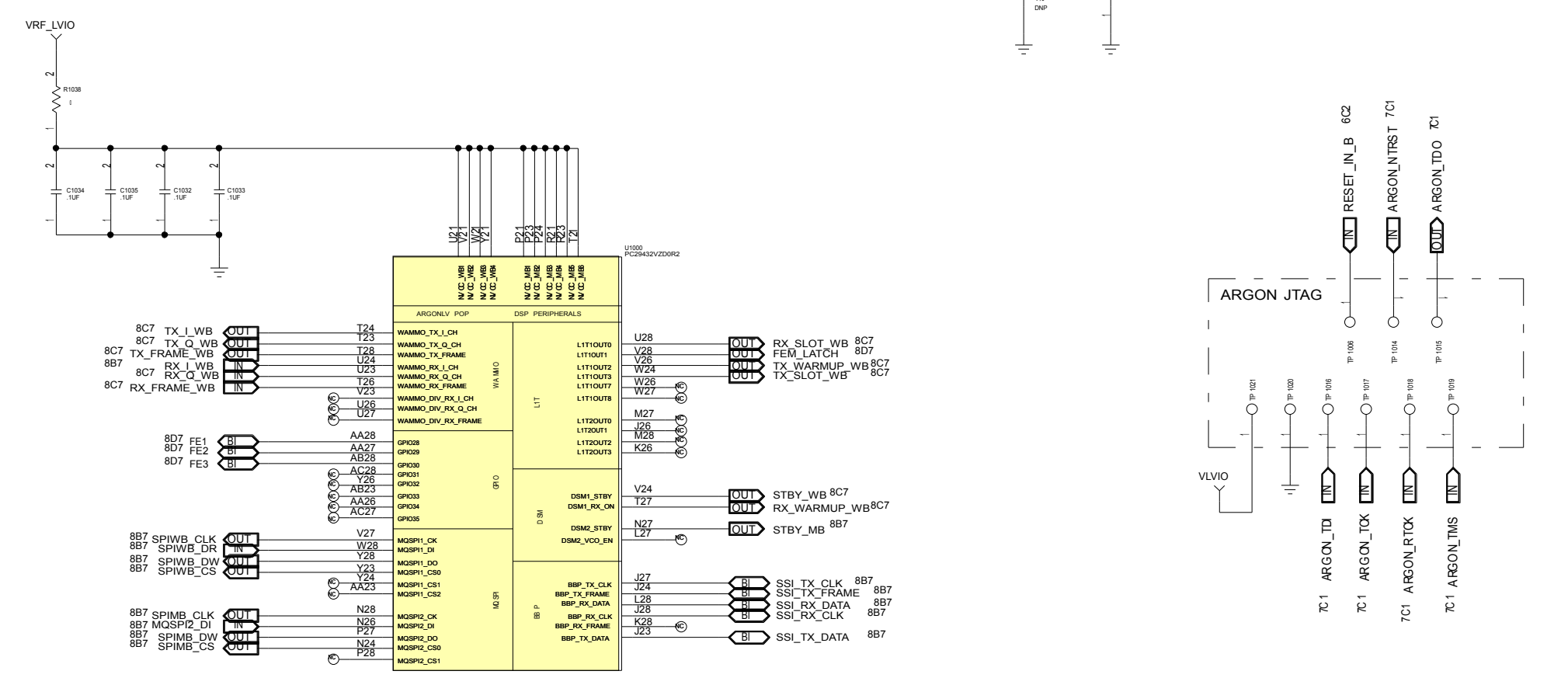
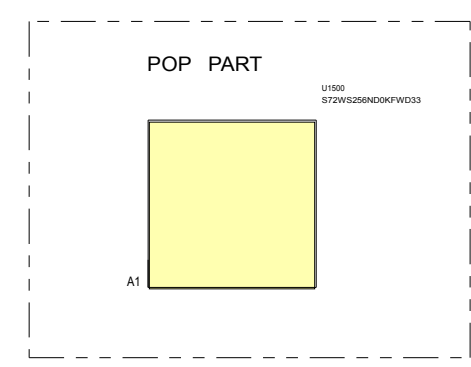
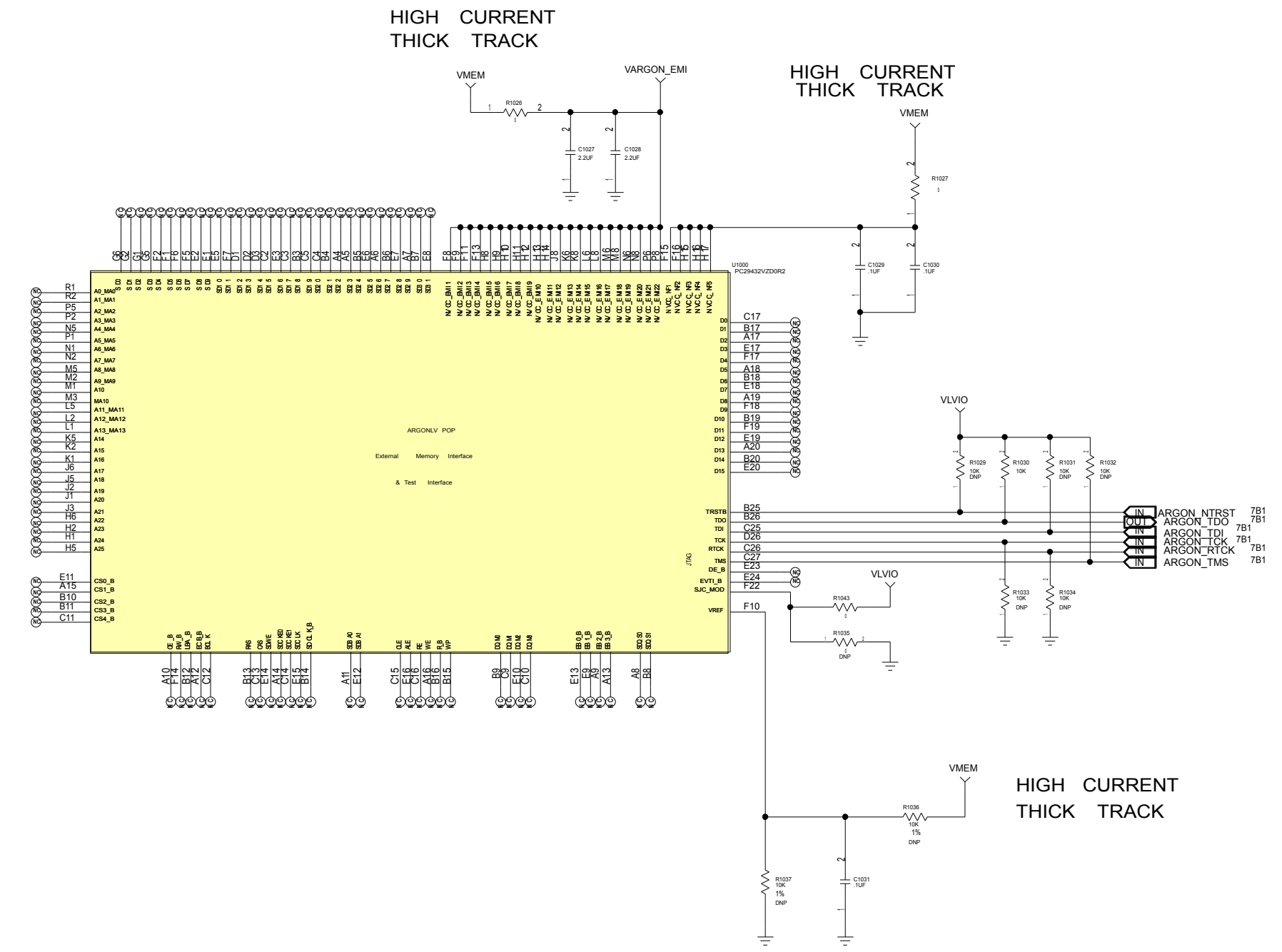
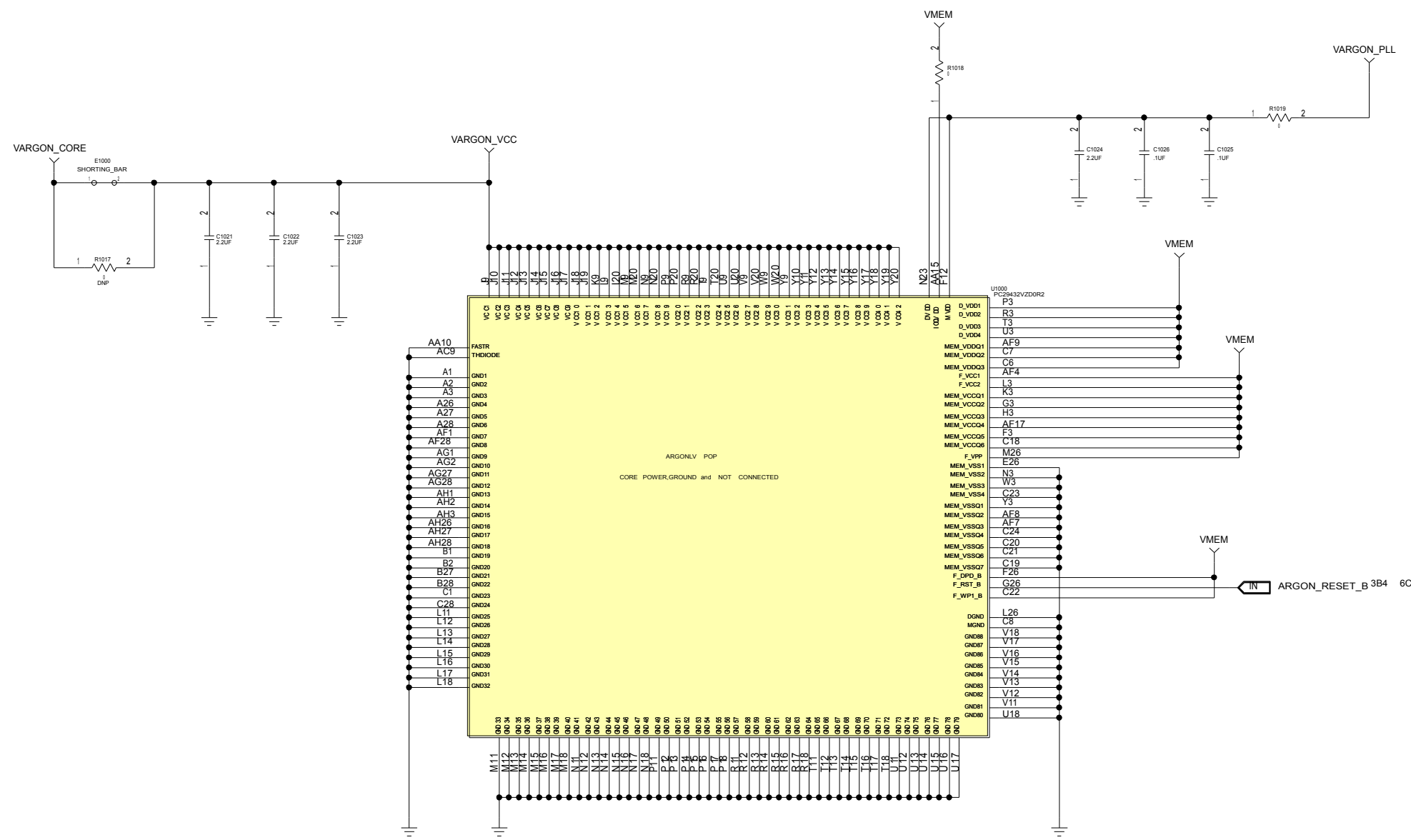

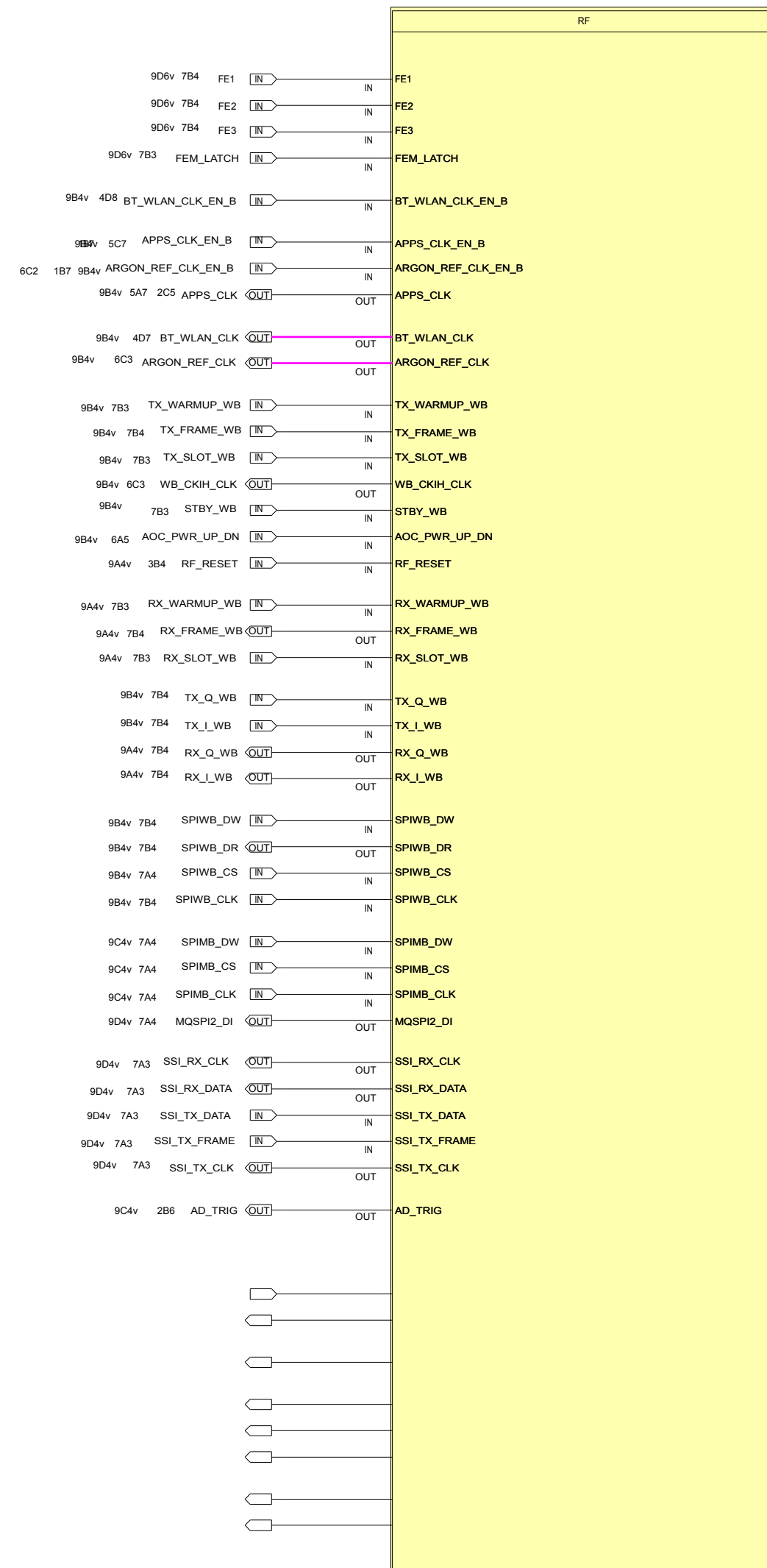

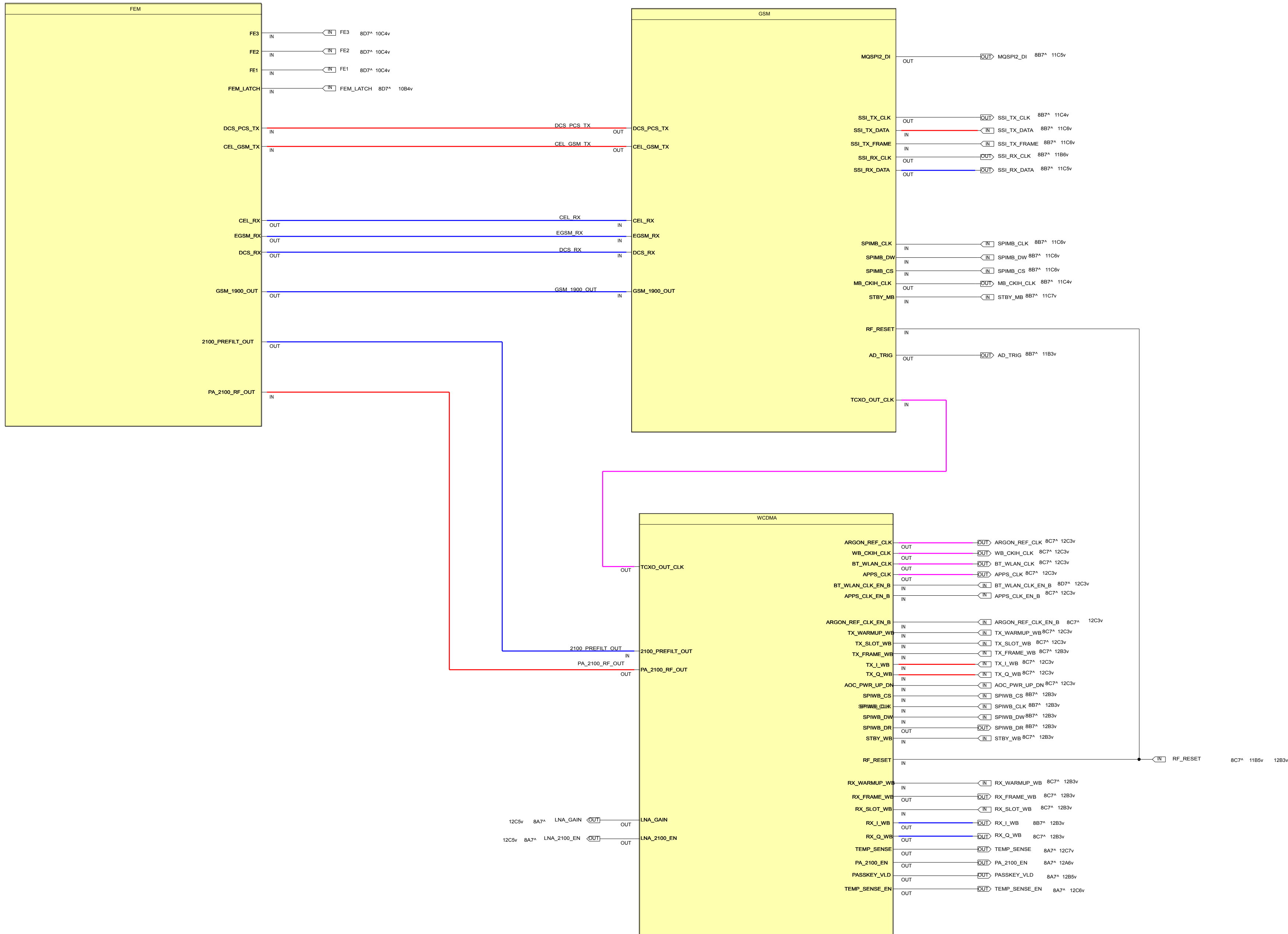

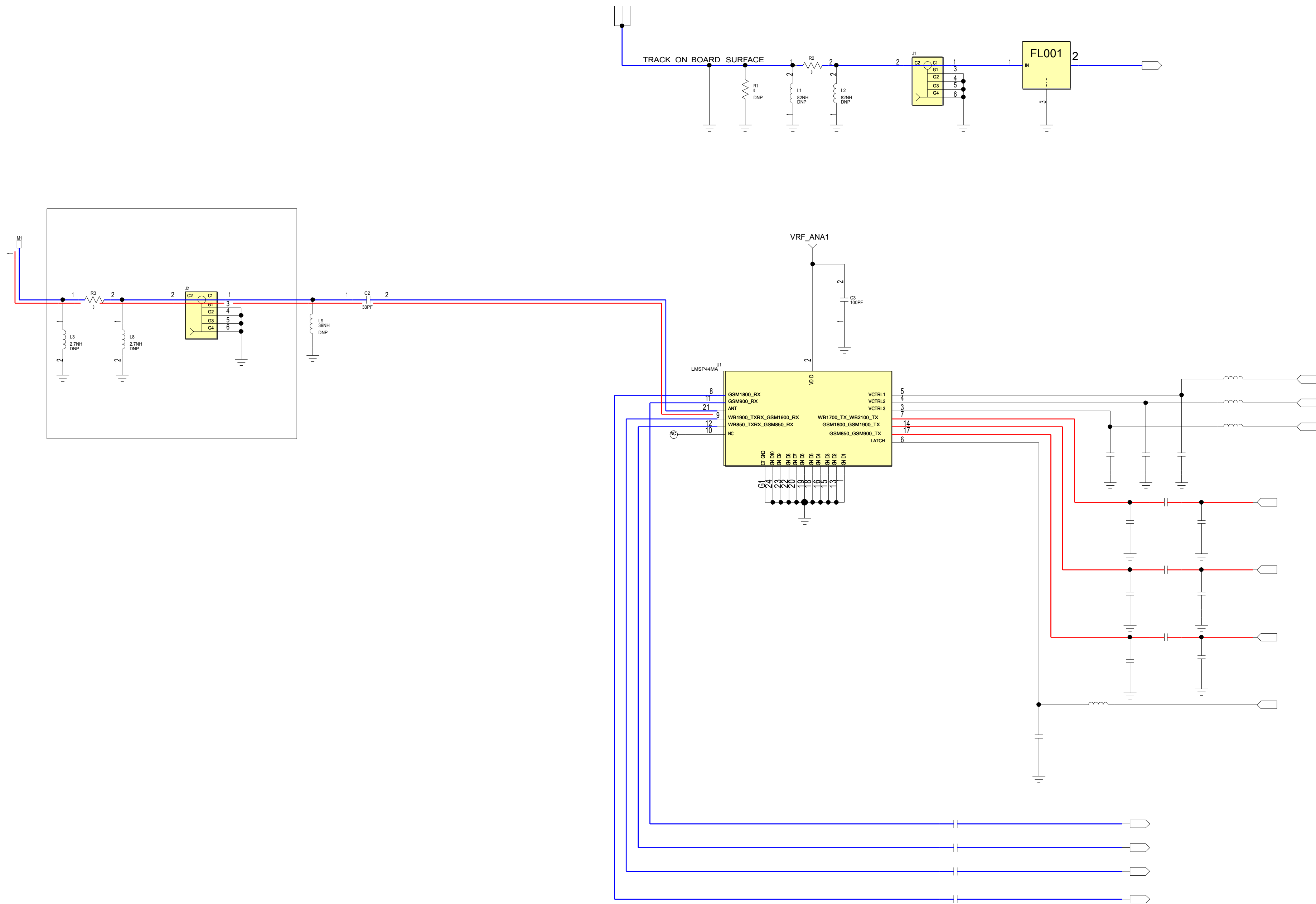

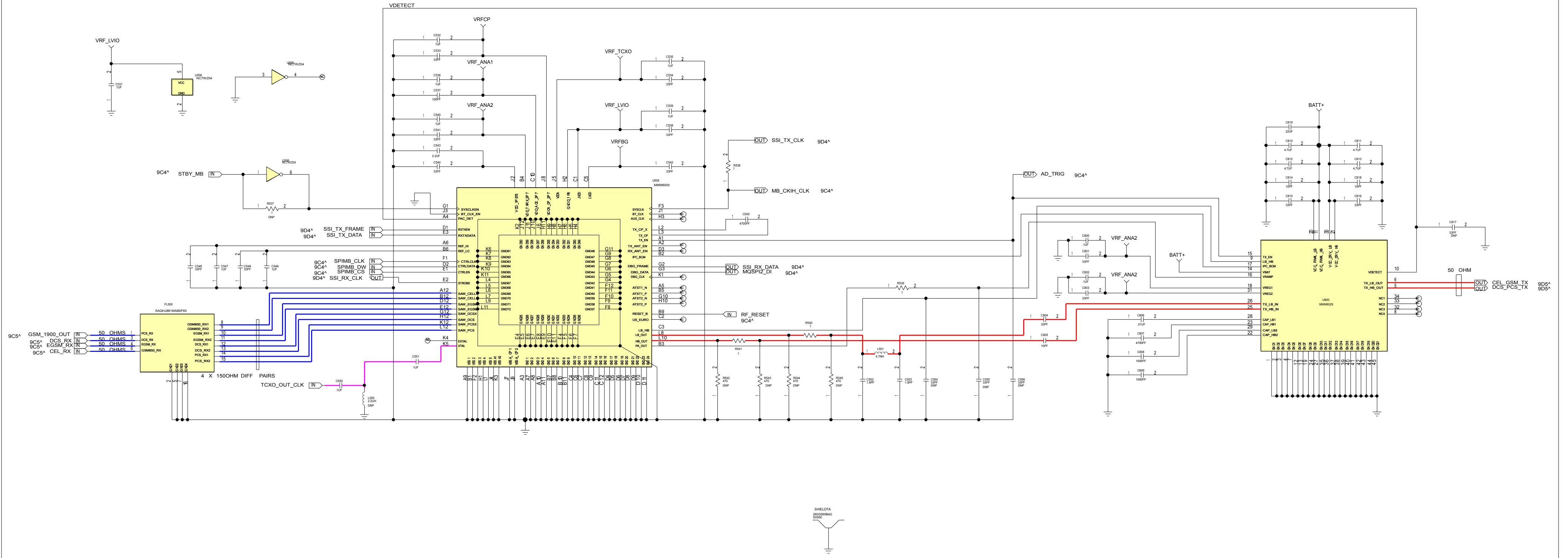

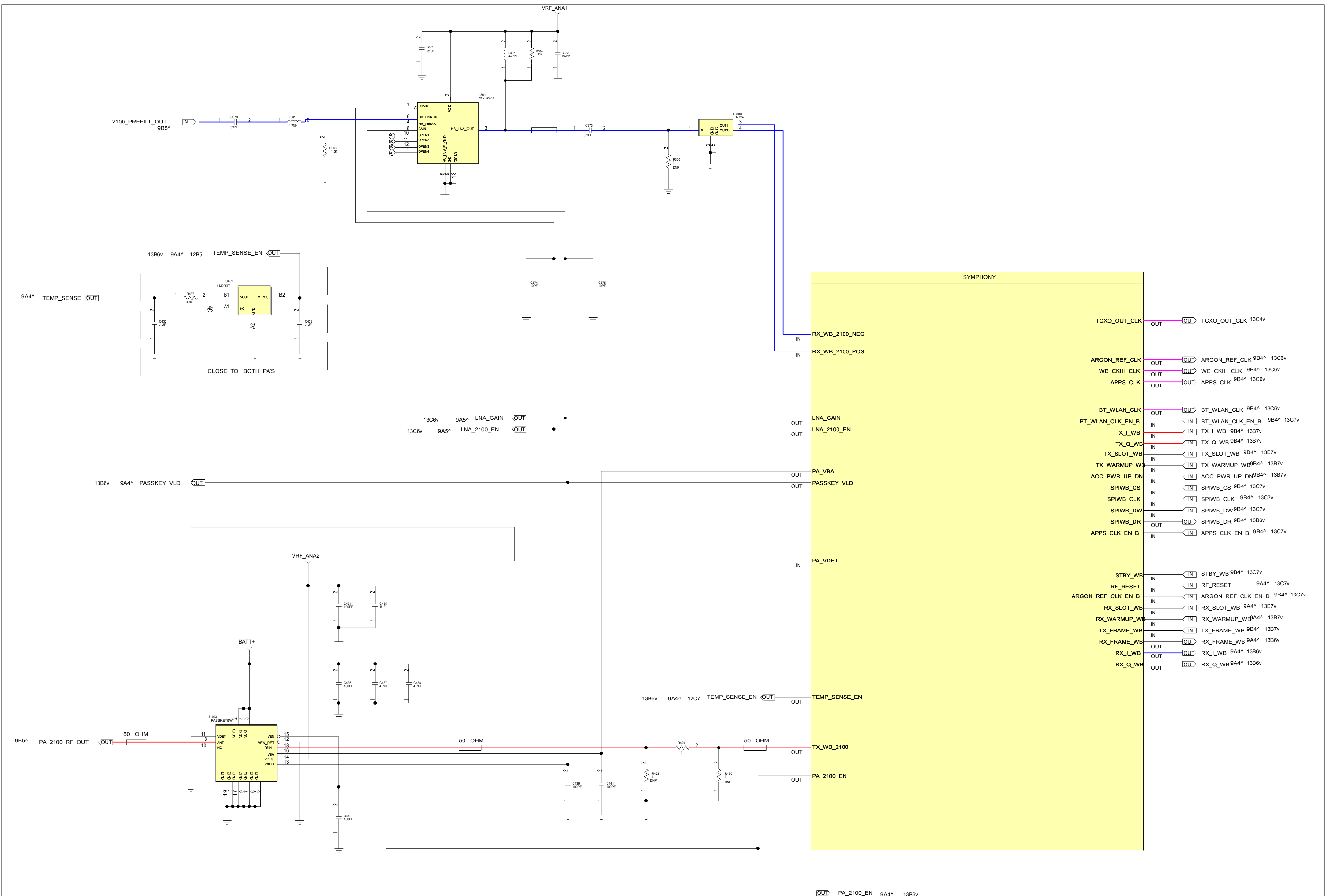

SYMPHONY	
TCXO_OUT_CLK	OUT TCXO_OUT_CLK 13C4v
ARGON_REF_CLK	OUT ARGON_REF_CLK 9B4^ 13C6v
WB_CKIH_CLK	OUT WB_CKIH_CLK 9B4^ 13C6v
APPS_CLK	OUT APPS_CLK 9B4^ 13C6v
BT_WLAN_CLK	OUT BT_WLAN_CLK 9B4^ 13C6v
BT_WLAN_CLK_EN_B	IN BT_WLAN_CLK_EN_B 9B4^ 13C7v
TX_L_WB	IN TX_L_WB 9B4^ 13B7v
TX_Q_WB	IN TX_Q_WB 9B4^ 13B7v
TX_SLOT_WB	IN TX_SLOT_WB 9B4^ 13B7v
TX_WARMUP_WB	IN TX_WARMUP_WB 9B4^ 13B7v
AOC_PWR_UP_DN	IN AOC_PWR_UP_DN 9B4^ 13B7v
SPIWB_CS	IN SPIWB_CS 9B4^ 13C7v
SPIWB_CLK	IN SPIWB_CLK 9B4^ 13C7v
SPIWB_DW	IN SPIWB_DW 9B4^ 13C7v
SPIWB_DR	OUT SPIWB_DR 9B4^ 13B6v
APPS_CLK_EN_B	IN APPS_CLK_EN_B 9B4^ 13C7v
STBY_WB	IN STBY_WB 9B4^ 13C7v
RF_RESET	IN RF_RESET 9A4^ 13C7v
ARGON_REF_CLK_EN_B	IN ARGON_REF_CLK_EN_B 9B4^ 13C7v
RX_SLOT_WB	IN RX_SLOT_WB 9A4^ 13B7v
RX_WARMUP_WB	IN RX_WARMUP_WB 9A4^ 13B7v
TX_FRAME_WB	IN TX_FRAME_WB 9B4^ 13B7v
RX_FRAME_WB	OUT RX_FRAME_WB 9A4^ 13B6v
RX_L_WB	OUT RX_L_WB 9A4^ 13B6v
RX_Q_WB	OUT RX_Q_WB 9A4^ 13B6v

