



MOTOROLA

Level 1 & 2 Service Manual

6809510A67-O

MOTORIZR™ Z8



UMTS 2100, GSM 850/900/1800/1900 MHz

MOTOROLA and the Stylized M Logo are registered in the US Patent & Trademark Office.
All other product or service names are the property of their respective owners.

© Motorola, Inc. 20007.
All rights reserved.

Mobile Devices Business,
Sawgrass International Concourse
789 International Parkway
Room S2C
Sunrise, FL 33325-6220

Contents

- Introduction** 1
 - Product Identification 1
 - Product Names 1
 - Product Changes 1
 - Regulatory Agency Compliance 1
 - Computer Program Copyrights 2
 - About This Service Manual 2
 - Warranty Service Policy 3
 - Parts Replacement 4
- Specifications** 5
- Product Overview** 7
 - Features 7
- General Operation** 9
 - Controls, Indicators, and Input/Output (I/O) Connectors 9
 - Battery Information 11
- Tools and Test Equipment** 12
- Disassembly** 13
 - Removing and Replacing the Battery Door and Battery 13
 - Removing and Replacing the Subscriber Identity Module (SIM) 15
 - Removing and Replacing the Memory Card 16
 - Removing and Replacing the Rear Housing and Transceiver Board Assembly 17
 - Removing and Replacing the Expansion PC Board 22
 - Removing and Replacing the GSM/3G-2100 MHz TX Antenna 23
- Subscriber Identity Module (SIM) and Identification** 24
 - SIM 24
 - Personality Transfer 24
 - Identification 24
- Troubleshooting** 26
 - Manual Test Mode 26
 - Troubleshooting Chart 26
 - Programming: Software Upgrade and Flexing 28
 - Exploded View Diagram 29
 - Exploded View Parts List 30
 - Accessories 31

Introduction

Motorola® Inc. maintains a worldwide organization that is dedicated to provide responsive, full-service customer support. Motorola products are serviced by an international network of company-operated product care centers as well as authorized independent service firms.

Available on a contract basis, Motorola Inc. offers comprehensive maintenance and installation programs which enable customers to meet requirements for reliable, continuous communications.

To learn more about the wide range of Motorola service programs, contact your local Motorola products representative or the nearest Customer Service Manager.

Product Identification

Motorola products are identified by the model number on a label usually located under the battery. Use the entire model number when inquiring about the product. Numbers are also assigned to chassis and kits. Use these numbers when requesting information or ordering replacement parts.

Product Names

Product names are listed on the front cover. Product names are subject to change without notice. Some product names, as well as some frequency bands, are available only in certain markets.

Product Changes

When electrical, mechanical or production changes are incorporated into Motorola products, a revision letter is assigned to the chassis or kit affected, for example; -A, -B, or -C, and so on.

The chassis or kit number, complete with revision number is imprinted during production. The revision letter is an integral part of the chassis or kit number and is also listed on schematic diagrams, and printed circuit board layouts.

Regulatory Agency Compliance

This device complies with Part 15 of the FCC Rules. Operation is subject to the following conditions:

- This device may not cause any harmful interference, and
- this device must accept interference received, including interference that may cause undesired operation

This class B device also complies with all requirements of the Canadian Interference-Causing Equipment Regulations (ICES-003).

Cet appareil numérique de la classe B respecte toutes les exigences du Règlement sur le matériel brouilleur du Canada.

Computer Program Copyrights

The Motorola products described in this manual may include Motorola computer programs stored in semiconductor memories or other media that are copyrighted with all rights reserved worldwide to Motorola. Laws in the United States and other countries preserve for Motorola, Inc. certain exclusive rights to the copyrighted computer programs, including the exclusive right to copy, reproduce, modify, decompile, disassemble, and reverse-engineer the Motorola computer programs in any manner or form without Motorola's prior written consent. Furthermore, the purchase of Motorola products shall not be deemed to grant either directly or by implication, estoppel, or otherwise, any license or rights under the copyrights, patents, or patent applications of Motorola, except for a nonexclusive license to use the Motorola product and the Motorola computer programs with the Motorola product.

About This Service Manual

Using this service manual and the suggestions contained in it assures proper installation, operation, and maintenance of Z8 telephones. Refer questions about this manual to the nearest Customer Service Manager. This manual contains mechanical service information required for the equipment described and is current as of the printing date.

Audience

This document aids service personnel in testing and repairing Z8 telephones. Service personnel should be familiar with electronic assembly, testing, and troubleshooting methods, and with the operation and use of associated test equipment.

Scope

This manual provides basic information relating to Z8 telephones, and also to provide procedures and processes for repairing the units at Level 1 and 2 service centers including:

- Unit swap out
- Repairing of mechanical faults
- Basic modular troubleshooting
- Testing and verification of unit functionality
- Initiate warranty claims and send faulty modules to Level 3 or 4 repair centers.

Conventions

Special characters and typefaces, listed and described below, are used in this publication to emphasize certain types of information.



Note: Emphasizes additional information pertinent to the subject matter.



Caution: Emphasizes information about actions which may result in equipment damage.



Warning: Emphasizes information about actions which may result in personal injury.



Keys to be pressed are represented graphically. For example, instead of “Press the End key”, you will see “Press ”.

Information from a screen is shown in text as similar as possible to what displays on the screen. For example, **PHONEBOOK**.

Information that you need to type is printed in **boldface type**

Warranty Service Policy

The product is sold with the standard 12 month warranty terms and conditions. Accidental damage, misuse, and extended warranties offered by retailers are not supported under warranty. Non warranty repairs are available at agreed fixed repair prices.

Out of Box Failure Policy

The standard out of box failure criteria applies. Customer phones that fail very early on after the date of sale, are to be returned to Manufacturing for root cause analysis, to guard against epidemic criteria. Manufacturing to bear the costs of early life failure.

Product Support

Customer's original phones will be repaired but not refurbished as standard. Appointed Motorola Service Hubs will perform warranty and non-warranty field service for level 2 (assemblies) and level 3 (limited PCB component). Motorola High Tech Centers will perform level 4 (full component) repairs.

Customer Support

Customer support is available through dedicated Call Centers and in-country help desks. Product-Service training should be arranged through the local Motorola Support Center.

Parts Replacement

When ordering replacement parts or equipment, include the Motorola part number and description used in the service manual.

When the Motorola part number of a component is not known, use the product model number or other related major assembly along with a description of the related major assembly and of the component in question.

Replacement Parts Service Division (RPSD)

Order replacement parts, test equipment, and manuals from RPSD.

U.S.A.

Phone: 800-422-4210

FAX: 800-622-6210

Website: <http://businessonline.motorola.com>

Outside U.S.A.

Phone: 847-538-8023

FAX: 847-576-3023

EMEA

Phone: +49 461 803 1404

Website: <http://emeaonline.motorola.com>

Asia

Phone: +65 648 62995

Website: <http://asiaonline.motorola.com>

Specifications

Table 1. Specifications

Function	Specification
Frequency Range EGSM	TX: 880 - 915 MHz Frequency (MHz) = $890 + (0.2 \times n)$ where: $0 \leq n \leq 124$ Frequency (MHz) = $890 + (0.2 \times (n - 1024))$ where: $955 \leq n \leq 1023$ RX: 925 - 960 MHz Frequency (MHz) = $935 + (0.2 \times n)$ where: $0 \leq n \leq 124$ Frequency (MHz) = $935 + (0.2 \times (n - 1024))$ where: $955 \leq n \leq 1023$
Frequency Range DCS	TX: 1710 to 1785 MHz Frequency (MHz) = $1710.2 + (0.2 \times (n - 512))$ where: $512 \leq n \leq 885$ RX: 1805.2 to 1879.8 MHz Frequency (MHz) = $1805.2 + (0.2 \times (n - 512))$ where: $512 \leq n \leq 885$
Frequency Range PCS	TX: 1850 to 1910 MHz Frequency (MHz) = $1850.2 + (0.2 \times (n - 512))$ where: $512 \leq n \leq 810$ RX: 1930 to 1990 MHz Frequency (MHz) = $1930.2 + (0.2 \times (n - 512))$ where: $512 \leq n \leq 810$
Frequency Range UMTS	TX: 1920 to 1980 MHz Frequency (MHz) = $\text{UARFCN}^1 \div 5$, where: $9612 \leq \text{UARFCN}^1 \leq 9888$ UARFCN ¹ in increments of 25 RX: 2110 to 2170 MHz Frequency (MHz) = $\text{UARFCN}^1 \div 5$, where: $10562 \leq \text{UARFCN}^1 \leq 10838$ UARFCN ¹ in increments of 25
Channel Spacing	200 kHz (GSM, DCS, PCS), 5 MHz UMTS
Channels	174 EGSM, 374 DCS, 274 PCS carriers with 8 channels per carrier, 11 UMTS
Duplex Spacing	45 MHz GSM, 95 MHz DCS, 80 MHz PCS, 190 MHz UMTS
Modulation	GMSK AT BT = 0.3 (GSM, DCS, PCS), QPSK (UMTS)
Transmitter Phase Accuracy	5 degrees RMS, 20 Degrees peak
Frequency Error	± 0.1 ppm
Input/Output Impedance	50 ohms (nominal)
Nominal Operating Voltage	3.6 Vdc $\pm 10\%$ (battery) +4.4 Vdc $\pm 10\%$ (external connector)
Dimensions (xyz)	107.9 mm, 50.6mm, 15.45mm
Size	77.6 cc
Weight	112 g
Display	16M color TFT, 320 x 240, 2.2"
Battery Life (1030mAh) ²	GSM: Talk time: Up to 215 minutes GSM: Standby time: Up to 220 to 260 hours WCDMA Talk time: 5 hours WCDMA Standby time: 384 hours WCDMA Video talk time: Up to 300 minutes
Nominal Operating Temperature Range	-10° C to +55° C

GSM System Functions	Specification
Speech Coding Type	Regular Pulse excitation / linear predictive coding with long term prediction (RPE LPC with LTP)
Bit Rate	13.0 kbps
RF Power Output	32 dBm nominal GSM, 28.5 dBm nominal DCS / PCS
Spurious Emissions	-36 dBm from 0.1 to 1 GHz, -30 dBm from 1 to 4 GHz
Receive Sensitivity	-102 dBm GSM, -102 dBm DCS / PCS
RX Bit Error Rate	< 2%

UMTS System Functions	Specification
Speech Coding Type	Adaptive Multirate (AMR)
RF Power Output	21 dBm
Spurious Emissions	-36 dBm from 0.1 to 1 GHz, -30 dBm from 1 to 4 GHz
Error Vector Magnitude	< 17.5%
PN9 Bit Error Rate (VER)	0.1% @12.2K, -106.7 dBm
ACLR	-33 dBm @ ± 5 MHz, -43 dBm @ ± 10 MHz

Product Overview

Motorola Z8 mobile telephones feature Wideband Code Division Multiple Access (WCDMA) technology, and global system for mobile communications (GSM) air interface. The mobile telephone uses a simple icon and graphical-based user interface (UI) for easier operation, allows short message service (SMS) text messaging, and includes clock, alarm, datebook, calculator, and caller profiling personal management tools. The Z8 operates within the GSM 850/900MHz, DCS 1800 MHz, PCS 1900 MHz, and UMTS 2100 MHz bands.

Z8 telephones support HSPDA, GPRS, SMS, and MMS in addition to traditional circuit switched transport technologies. High Speed Downlink Packet Access (HSPDA) is a wireless radio broadband data standard adopted by many WCDMA mobile phone service providers. HSPDA is significantly faster than GPRS, providing mobile devices with air interface speeds from 384kbps to 3.5Mbps. HSPDA, where available, provides substantial increases in mobile data communications performance and the efficient use of radio spectrum.

HSPDA allows the delivery of advanced mobile services, such as the streaming of video and music clips, full multimedia messaging, high-speed internet access and e-mail on the move.

The telephones are made of polycarbonate plastic. The display and speaker, as well as the transceiver printed circuit board (PCB), microphone, charger and headphone connectors, and buttons are contained within the thin kicking slider form-factor housing. The 1030 mAh Lithium Ion (Li Ion) battery provides up to 5 hours of talk time in UMTS mode with up to 384 hours of standby time¹. The phone accepts 3V and 1.8V mini subscriber identity module (SIM) cards which fit into the SIM holder under the rear housing cover. The telephone features a 240 x 320, 16M QVGA TFT color display and an internal antenna.

Features

Z8 telephones use advanced, self-contained, sealed, custom integrated circuits to perform the complex functions required for GSM and UMTS communication. Aside from the space and weight advantage, microcircuits enhance basic reliability, simplify maintenance, and provide a wide variety of operational functions.

Features available include:

- Messaging/WAP: SMS, MMS, EMS, email (POP3/IMAP4/SMTP/SSL), Opera browser
- OS/Applications: 2-softkey UI version of UIQ 3.1/Symbian 9.2
- Special Features: Media Studio with full Music support and 30fps H.264 video
- Camera: 2MP, 8x digital zoom, Flash
- Video: MPEG4, H.263, H.264
- Audio: MP3, AAC/AAC+/AAC+E, AMR-NB, XMF, WAV / 40 MIDI Levels
- Connectivity: EMU (mini USB), Bluetooth including A2DP, AVACP profiles
- Server based solutions: OMA DM/DS, FOTA, OMA DRM,
- FOTA (Firmware Over The Air)
- Native Media player
- Video capture, playback
- Lower voltage technology that provides increased standby and talk times
- Extended GSM (EGSM) channels

1. All talk and standby times are approximate and depend on network configuration, signal strength, and features selected. Standby times are quoted as a range from DRX=2 to DRX=9. Talk times are quoted as a range from DTX off to DTX on.

-
- Tri-coder/decoder (CODEC) that allows full rate, half rate, and enhanced full rate modes of transmission
 - Supports MP3, AAC, AAC+, AAC+ enhanced, MIDI, AMR-NB, Streaming 3GPP
 - High quality playback (RV, H.263, MPEG4)
 - 5 hour video capture capable
 - Downloadable themes (ringers, images, sounds)
 - Text to Speech
 - Class 12 GPRS (2U/4D)
 - Enhanced Bluetooth® profiles, including stereo headset support.
 - High Speed synchronization with Desktop with USB 2.0 for faster music and personal information downloads.
 - Large (2.2 inch), high resolution (240x320), (TFT, 262K color display)
 - Approximately 80 Mbytes of built-in end user storage expandable to over 4 GB with removable memory (SD/MMC card)

Simplified Text Entry

Motorola Labs handwriting and predictive text entry. Press a key to generate a character, and a dynamic dictionary uses this to build and display a set of word or name options. This feature may not be available on the phone in all languages.

Caller Line Identification

Upon receipt of a call, the calling party's phone number is compared to the phone book. If the number matches a phone book entry, that name will be displayed. If there is no phone book entry, the incoming phone number will be displayed. In the event that no caller identification information is available, an incoming call message is displayed.



User must subscribe to a caller line identification service through their service provider.

Personal Information Management

The Z8 telephone contains a built in calendar with date book reminders and phonebook that can be synchronized easily to a computer.

General Operation

Controls, Indicators, and Input/Output (I/O) Connectors

The Z8 controls are located on the front and back of the device, and on the keyboard, as shown in Figures 1 and 2.



0702580

Figure 1. Telephone Controls and Indicators Locations (Front)

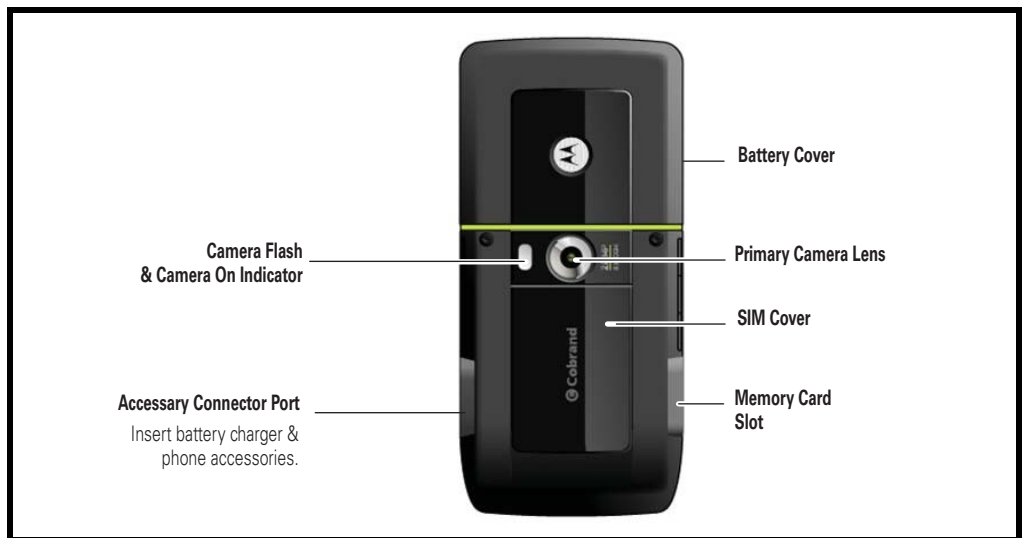

0614180

Figure 2. Telephone Controls and Indicators Locations (Back)

Figure 3 shows the main Screen display.

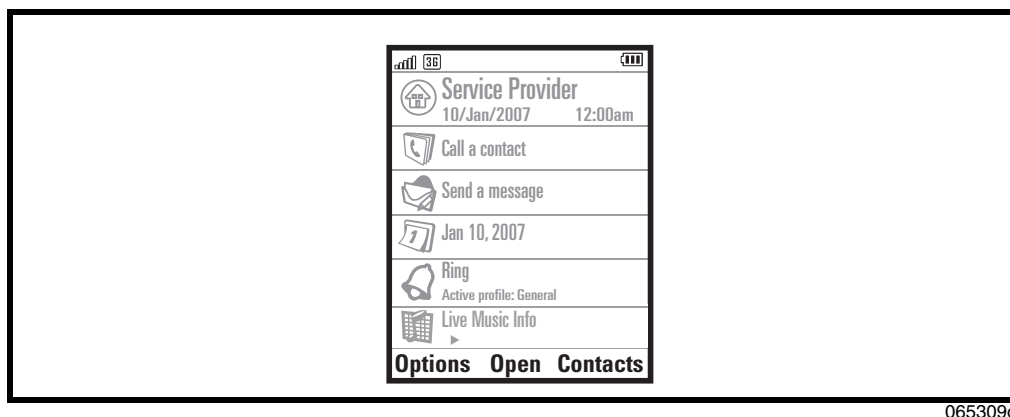



Figure 3. Main Screen Display

Status Indicators

The following status indicators may appear at the top of the display:

1. **Signal Strength Indicator** – Vertical bars show the strength of the network connection. Network services, such as calls may not be available when  or  appears.
2. **Network Indicator** – Shows when your phone is using a GSM connection (standard network access), GPRS connection (high speed network access), 3G connection (highest speed network and video calling) or *flight mode* (no network connection).

 GSM

 GPRS

 3G

 Flight mode

HSDPA

3. **Roam Indicator** – Shows when your phone is seeking or using a network outside your Home network.
4. **Bluetooth Indicator** – Shows current Bluetooth status. Indicators may include:

 Bluetooth on
(green)

 Bluetooth
active (blue)

 sending

5. **Calls Indicator** – Shows various call states. Indicators may include:

 active voice call

 active video
call

 missed call

6. **Message Indicator** – Shows when you receive an SMS, MMS, email or voicemail message. Indicators can include:

 SMS

 email

 MMS

 voicemail

7. **Sound Mode Indicator** – Shows the current sound mode.

-  silent
-  speakerphone
-  microphone muted

Menu Navigation

Z8 telephones are equipped with an icon and graphical-based user interface. All of the phone's features can be accessed with a 5-way navigation key that allows you to move easily through menus and select menu items.

Liquid Crystal Display (LCD)

The LCD provides an large color display with user-adjustable brightness settings for optimum readability in all light conditions. The large 240 x 320 pixel display provides room for entering text, viewing graphics, tapping icons, and system prompts.



Whether a phone displays all indicators depends on the programming and services to which the user subscribes.

Battery Information

Battery Charge Indicator

The telephone displays a battery charge indicator icon in the idle screen to indicate the battery charge level. The gauge shows four levels: 100%, 66%, 33%, and Low Battery.

Battery Removal

Removing the battery causes the device to immediately shut down and any pending work (partially entered phone book entries or outgoing messages, for example) is lost.



All batteries can cause property damage and/or bodily injury, such as, burns if a conductive material, such as, jewelry, keys, or beaded chains touch exposed terminals. The conductive material may complete an electrical circuit (short circuit) and become quite hot. Exercise care in handling any charged battery, particularly when placing it inside a pocket, purse, or other container with metal objects.



If the battery is removed while receiving a message, the message will be lost.



To ensure proper memory retention, turn the phone OFF before removing the battery.

Tools and Test Equipment

The following table lists tools and test equipment recommended for disassembly and reassembly of Z8 telephones. Use either the listed items or equivalents.

Table 1. General Test Equipment and Tools

Motorola Part Number ¹	Description	Application
RSX4043-A	Torque Driver	Used to remove and replace screws
--	#0 Cross Point Screwdriver	Used to remove cross point screws
—	Torque Driver Bit T-5 Plus, Apex 440-6IP Torx Plus or equivalent	Used with torque driver
—	Torque Driver Bit T-4 Plus, Apex 440-6IP Torx Plus or equivalent	Used with torque driver
See Table 5	Rapid Charger	Used to charge battery and to power device
0180386A82	Antistatic Mat Kit (includes 66-80387A95 antistatic mat, 66-80334B36 ground cord, and 42-80385A59 wrist band)	Provides protection from damage to device caused by electrostatic discharge (ESD)
6680388B67	Disassembly tool, plastic with flat and pointed ends (manual opening tool)	Used during assembly/disassembly of device
6680388B01	Tweezers, plastic	Used during assembly/disassembly
—	Digital Multimeter, HP34401A ²	Used to measure battery voltage
8102430Z04	GSM / DCS Test SIM	Used to enable manual test mode

1. To order in North America, contact Motorola Aftermarket and Accessories Division (AAD) at (800) 422-4210 or FAX (800) 622-6210; Internationally, AAD can be reached by calling (847) 538-8023 or faxing (847) 576-3023.

2. Not available from Motorola. To order, contact Hewlett Packard at (800) 452-4844.

Disassembly

The procedures in this section provide instructions for the disassembly of an Z8 telephone. Tools and equipment used for the phone are listed in Table 1, preceding.



Many of the integrated devices used in this equipment are vulnerable to damage from electrostatic discharge (ESD). Ensure adequate static protection is in place when handling, shipping, and servicing the internal components of this equipment.



Avoid stressing the plastic in any way to avoid damage to either the plastic or internal components.

Removing and Replacing the Battery Door and Battery



All batteries can cause property damage and / or bodily injury, such as, burns if a conductive material, such as, jewelry, keys, or beaded chains touch exposed terminals. The conductive material may complete an electrical circuit (short circuit) and become quite hot. Exercise care in handling any charged battery, particularly when placing it inside a pocket, purse, or other container with metal objects.

1. Ensure the phone is turned off.
2. Grasp both sides of the battery door firmly and slide it in the direction indicated in Figure 1. The battery door has been designed to fit very snugly onto the phone.

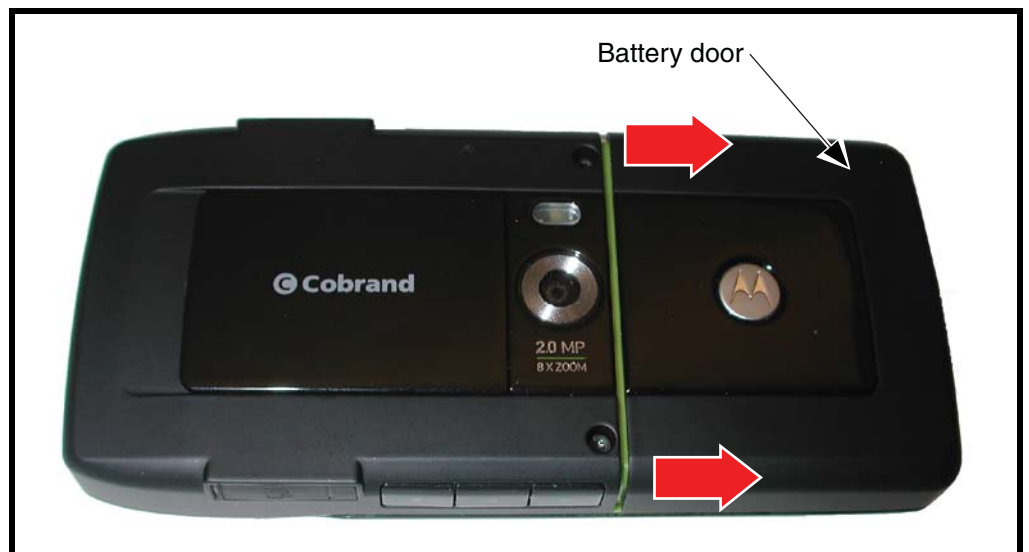

070261o

Figure 1. Removing the Battery Door

3. Lift the battery door completely off the phone.

4. Lift the end of the battery and remove it completely. See Figure 2.

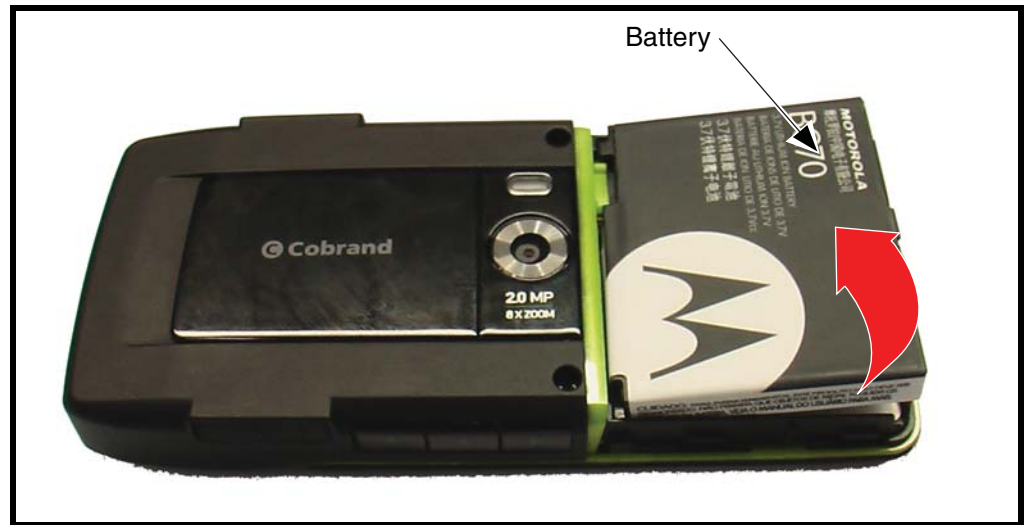

070262

Figure 2. Removing the Battery



There is a danger of explosion if the Lithium Ion battery is replaced incorrectly. Replace only with the same type of battery or equivalent as recommended by the battery manufacturer. Dispose of used batteries according to the manufacturer's instructions.

5. To replace, align the battery with the battery compartment so the contacts on the battery match the battery contacts in the phone.
6. Insert the battery, contacts side first, into the battery compartment and push down.
7. Insert the ridge at the bottom of the battery housing into the base of the phone, then push the cover down and snap it into place.

Removing and Replacing the Subscriber Identity Module (SIM)

1. Remove the battery door and battery as described in the procedures.
2. Slide the SIM cover as indicated in Figure 3 and lift it away from the phone.

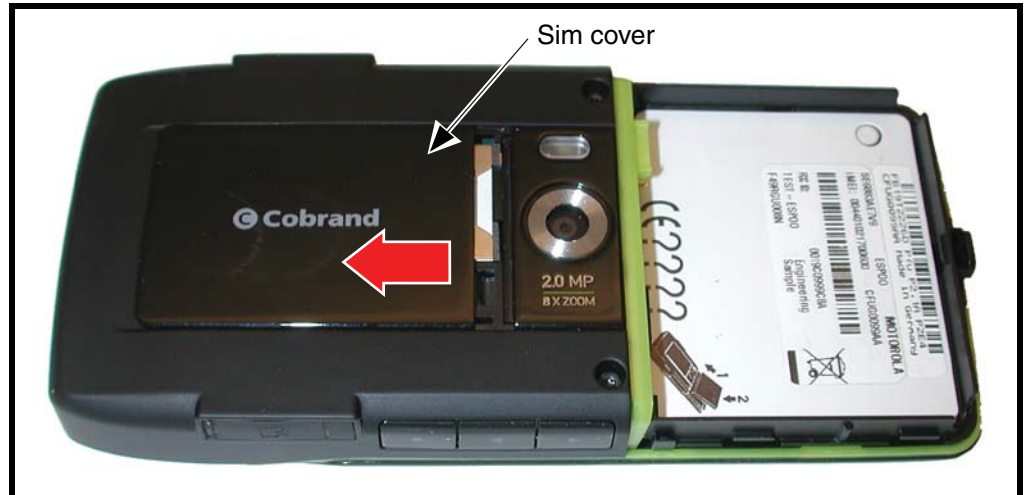

0702630

Figure 3. Removing the SIM Cover

3. Use the disassembly tool to slide the SIM out of the SIM holder, as shown in Figure 4.

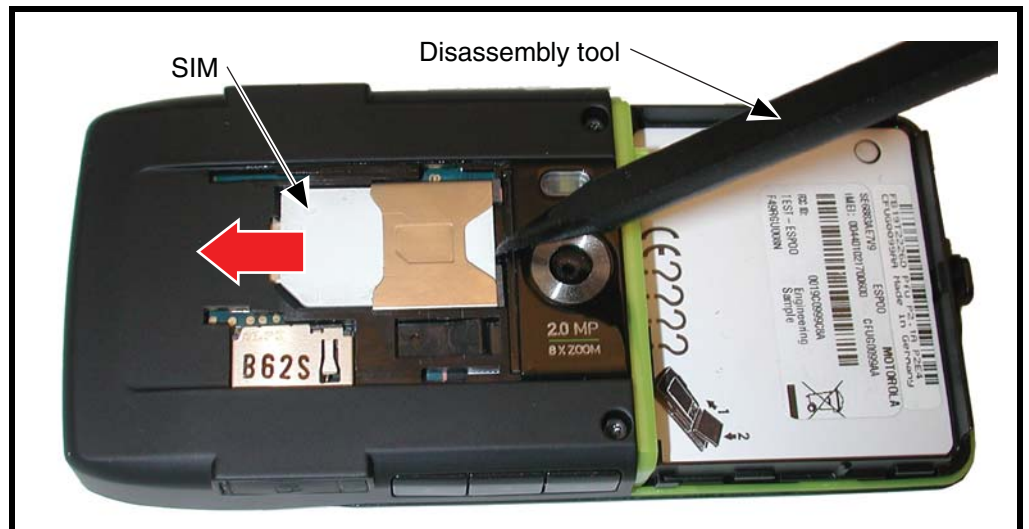

0702640

Figure 4. Removing the SIM

4. Carefully lift the SIM from the phone.
5. To replace, insert the SIM into the holder, ensuring the keyed corner of the SIM faces the top edge of the phone.
6. Place the SIM cover onto the phone and slide into position to lock the SIM cover.
7. Replace the battery and battery door as described in the procedures.

Removing and Replacing the Memory Card

1. Remove the battery door and battery as described in the procedures.
2. Open the memory card cover and slide the memory card inward to unlock it, then slide the memory card out of the phone.

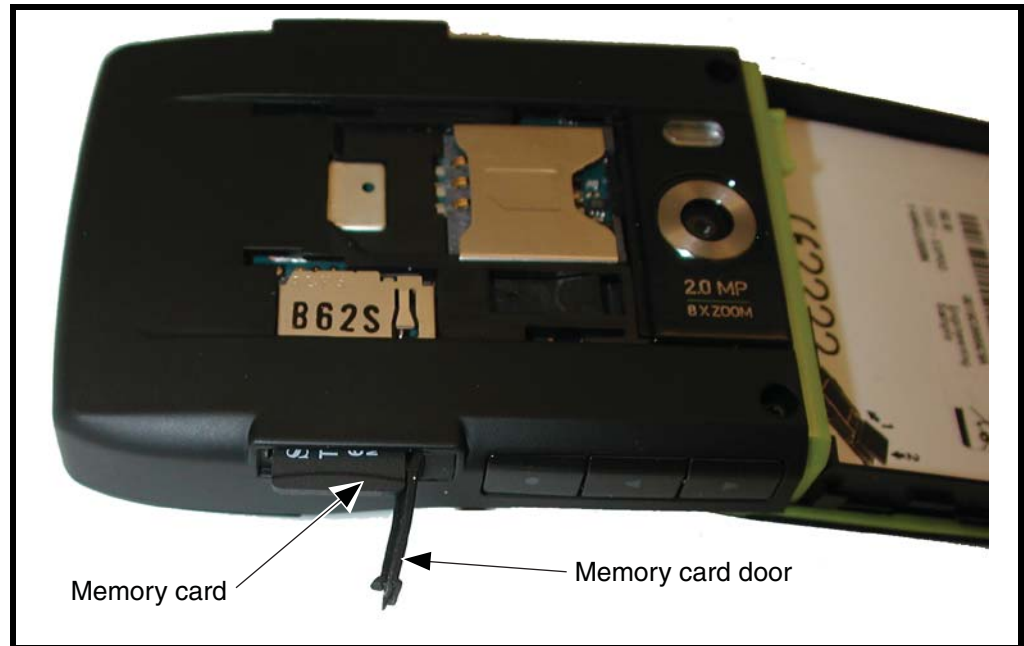

070282o

Figure 5. Removing the Memory Card

3. To replace, insert the memory card, with the metal contacts side facing down, all the way into the memory card slot until the card locks into position. A click is heard when the card is inserted correctly.

Removing and Replacing the Rear Housing and Transceiver Board Assembly



This product contains static-sensitive devices. Use anti-static handling procedures to prevent electrostatic discharge (ESD) and component damage.

1. Remove the battery cover, battery, and SIM as described in the procedures.
2. Insert the disassembly tool under the speaker grill and release the grill snaps at the bottom edge at the front of the phone. Avoid damage to the speaker located under the speaker grill.

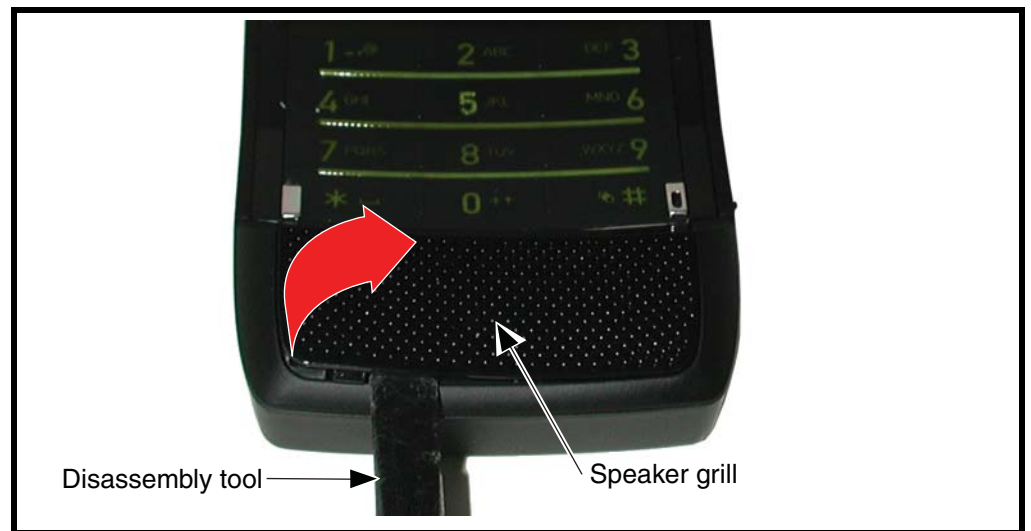
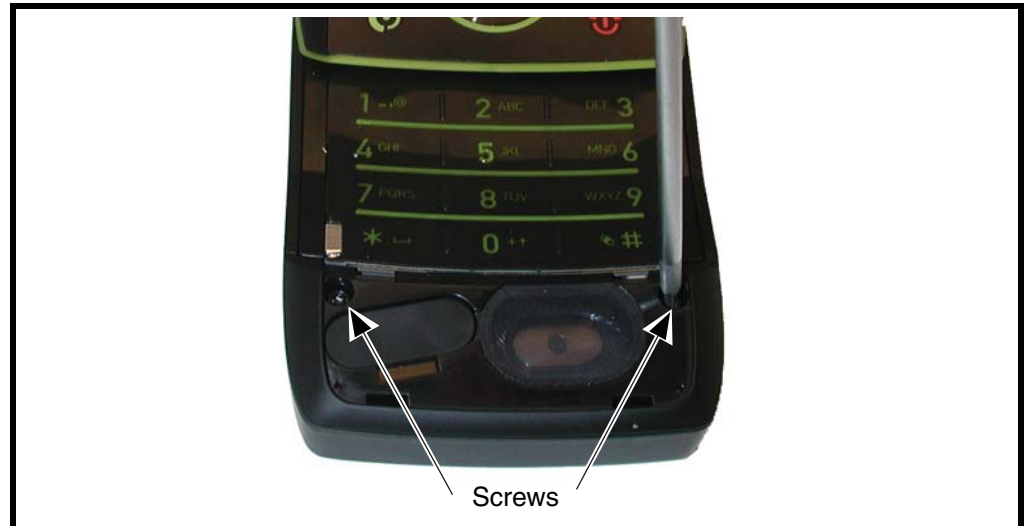

Figure 6. Removing the Speaker Grill

0702760

3. Carefully lift it away from the phone.

4. Use the T5 driver to remove 2 screws under the speaker grill. Set the screws aside for reuse.



0702750

Figure 7. Removing the Speaker Grill Screws

5. Use the disassembly tool to release the latches on the top and sides of the acoustic assembly.

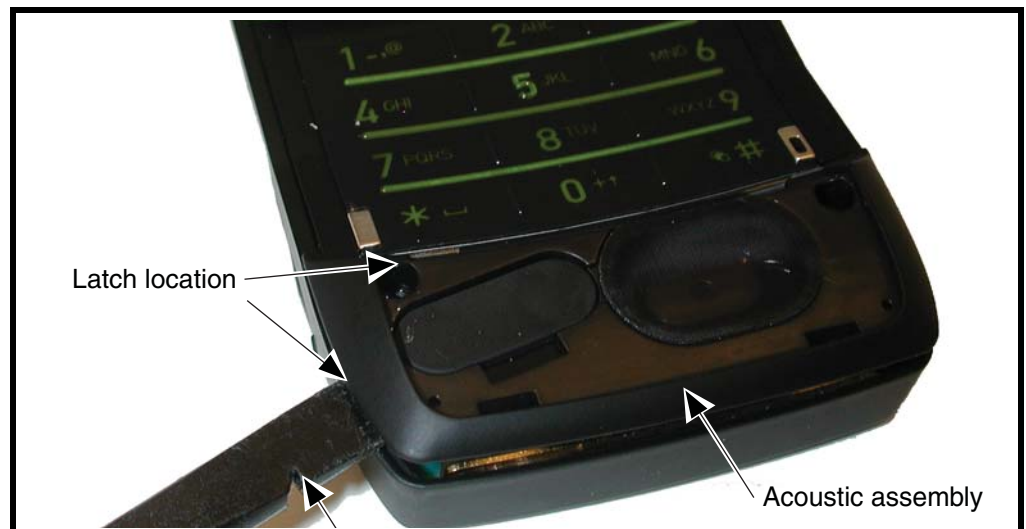

0702770

Figure 8. Removing the Acoustic Assembly

6. Turn the unit over and use the T5 driver to remove the two screws near the camera lens.

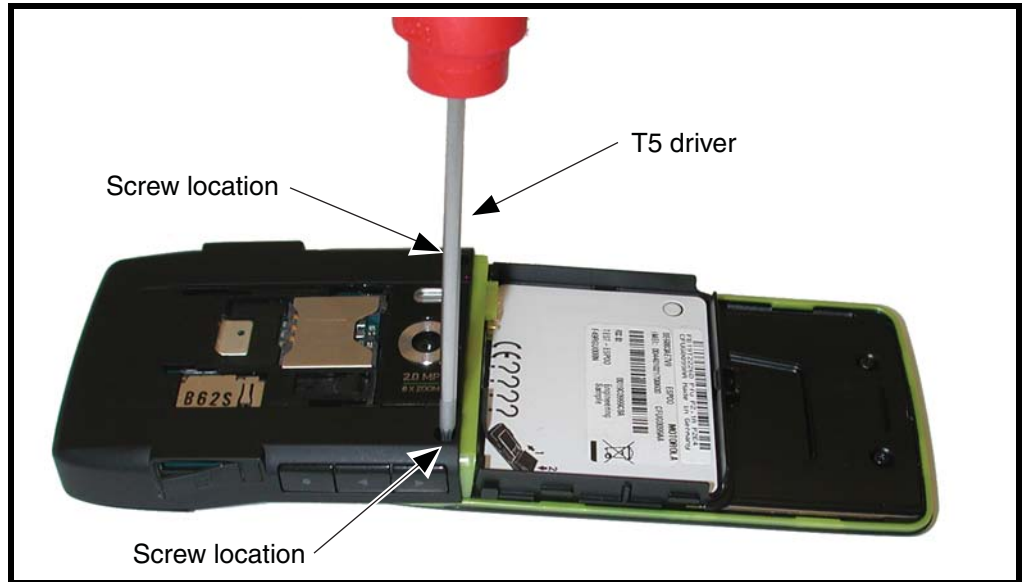

070283o

Figure 9. Removing the Rear Housing Screws

7. Remove the rear housing from the phone.
8. Carefully turn the unit over and use the disassembly tool to release the keypad flex connector.

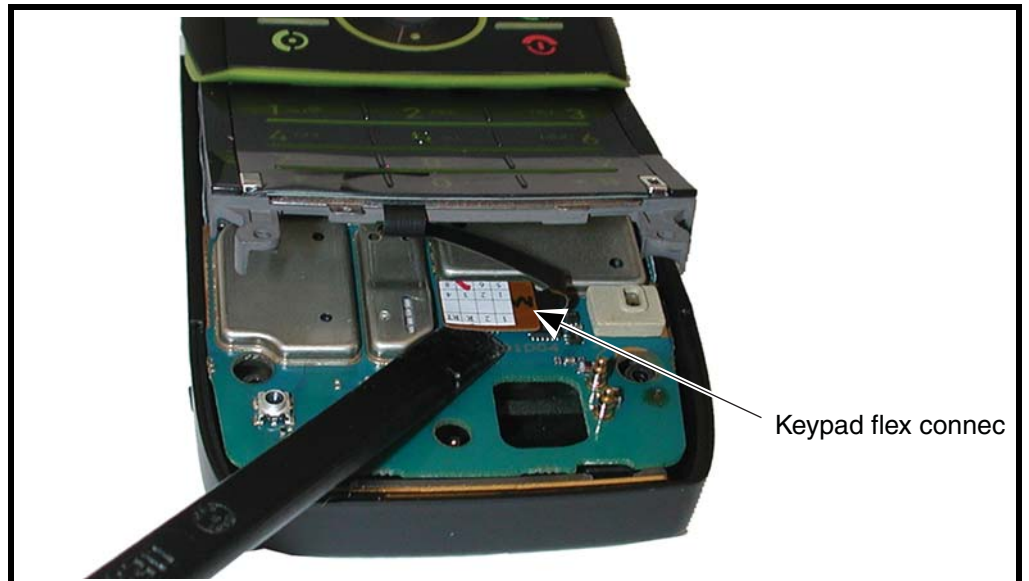

070284o

Figure 10. Removing the Keypad Flex Connector

9. Use the disassembly tool to release the display flex connector.

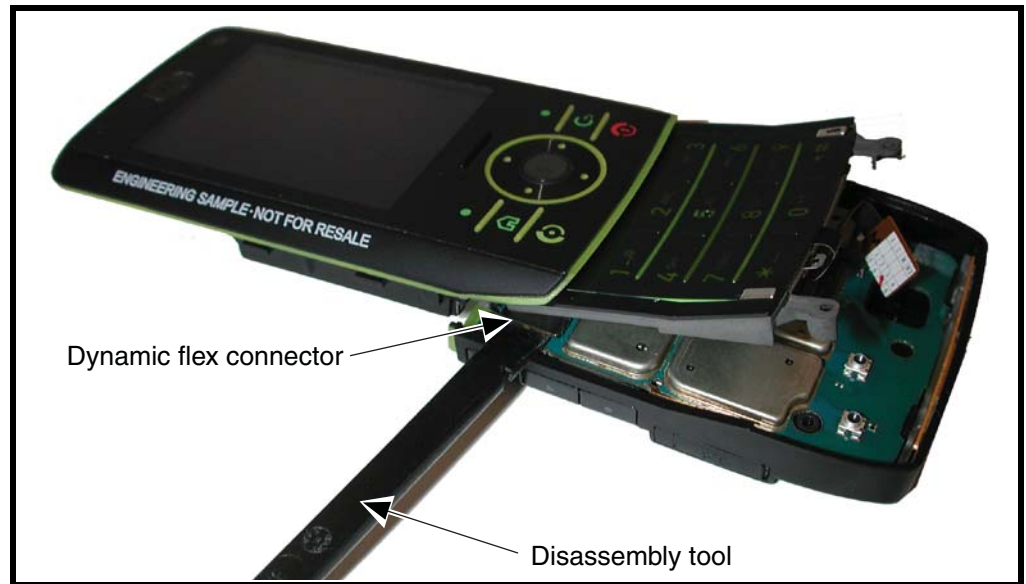

Figure 11. Removing the Dynamic Flex Connector

10. Turn the phone over, lift the bottom end of the transceiver PC board and use the disassembly tool to release the battery flex connector.

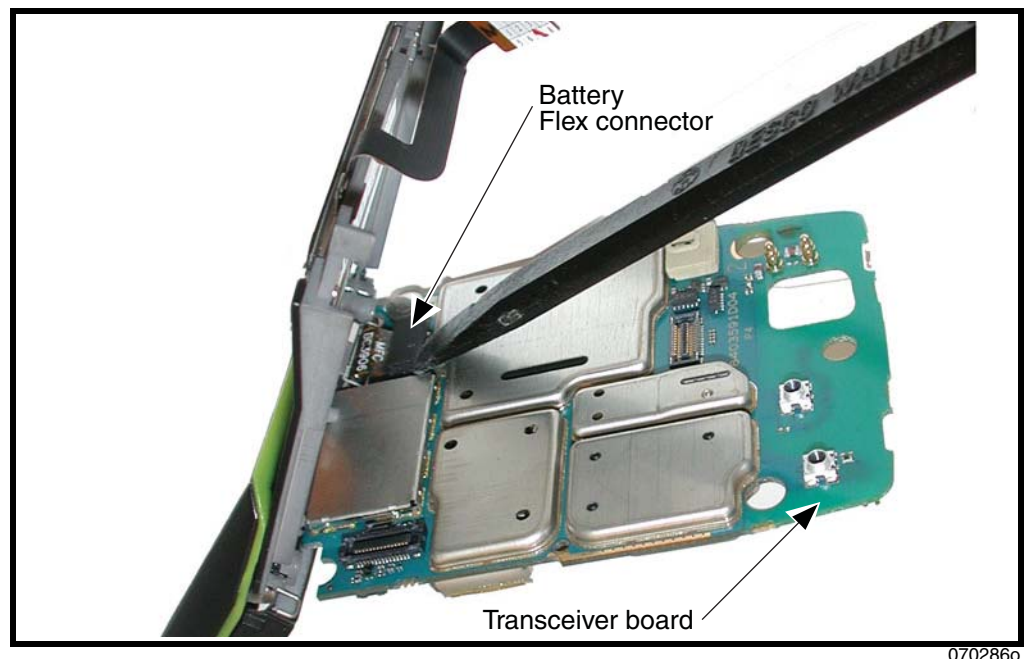

Figure 12. Removing the Battery Flex Connector

11. Carefully remove the transceiver PC board from the phone.

12. To replace, align the transceiver board next to the rear housing. Connect the flex connector to the socket on the transceiver PC board. Then carefully flip the entire PC board over into the rear housing. Ensure that the antenna connector aligns correctly with the antenna when the transceiver board is seated in the rear housing. Ensure the transceiver board is properly seated in the rear housing.

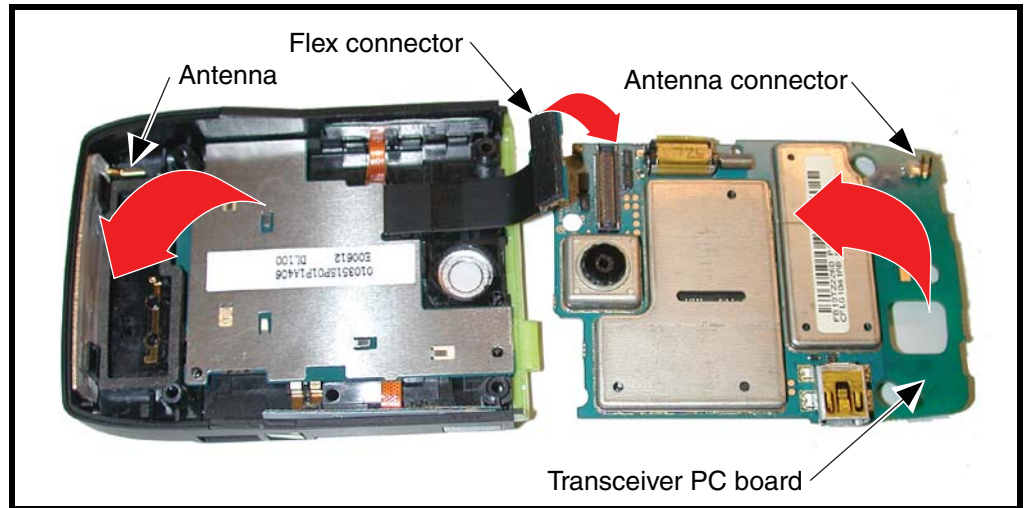

Figure 13. Replacing the Transceiver Board

13. Replace the transceiver PC board, rear housing, SIM, battery & battery door as described in the procedures.

Removing and Replacing the Expansion PC Board



This product contains static-sensitive devices. Use anti-static handling procedures to prevent electrostatic discharge (ESD) and component damage.

1. Remove the battery door, battery, SIM & rear housing and transceiver PC board as described in the procedures.
2. Using the disassembly tool, carefully slide the 2 side key switchdomes out of their slots on both sides of the rear housing assembly. Avoid damage to the flex cables.
3. Using the disassembly tool, carefully pry the expansion PC board out of the rear housing assembly (see Figure 14).

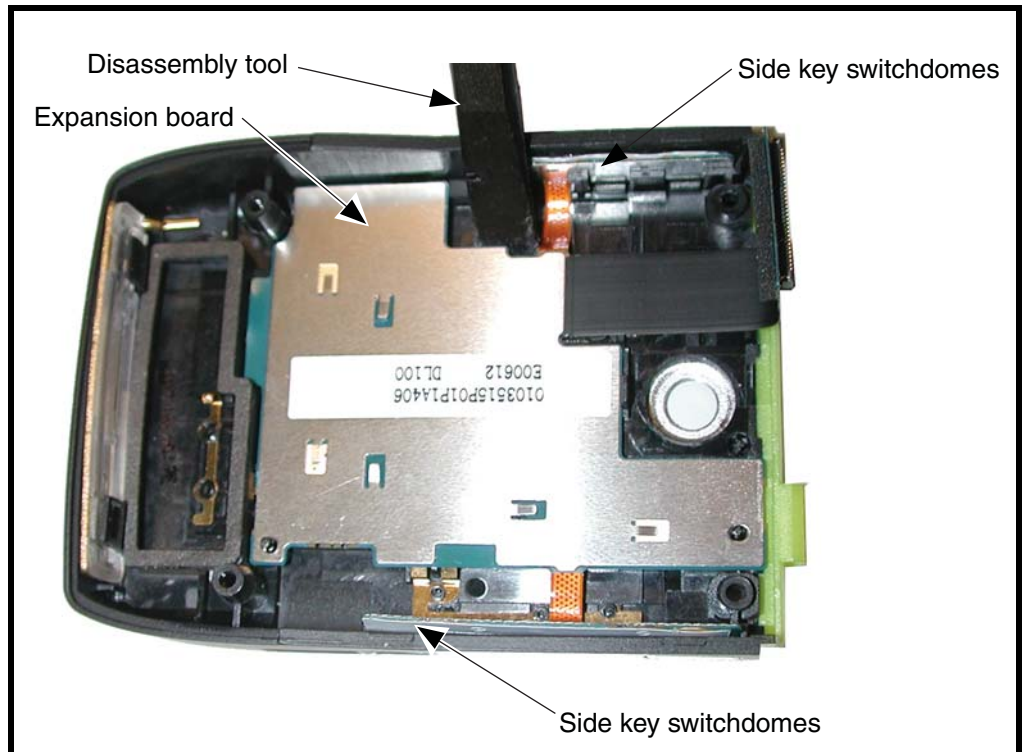
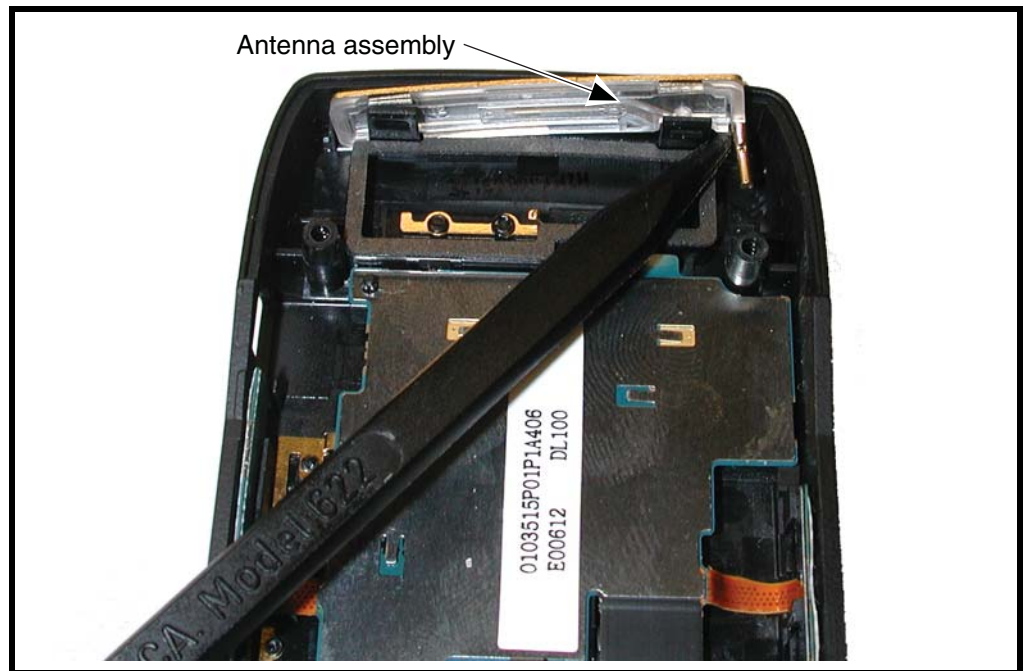

Figure 14. Removing and Replacing the Small PCB

4. To replace, insert the expansion pc board and board to board connector.
5. Install the two side key switchdomes.
6. Replace the rear housing, SIM, battery & battery door as described in the procedures.

Removing and Replacing the GSM/3G-2100 MHz TX Antenna

1. Use the disassembly tool to release the antenna from the rear housing (see Figure 15).



070291o

Figure 15. Removing the GSM/3G 2100 MHz Antenna

2. To replace, align the antenna assembly to the phone.
3. Carefully press the antenna assembly into position until the antenna assembly latches snap into position.

Subscriber Identity Module (SIM) and Identification

SIM

A SIM is required to access the existing local GSM network, or remote networks when traveling (if a roaming agreement has been made with the provider).

The SIM contains:

- All the data necessary to access GSM services.
- The ability to store user information, such as phone numbers.
- All information required by the network provider to provide access to the network.

Personality Transfer

A personality transfer is required when a phone is express exchanged or when the main board is replaced. Personality transfers reproduce the customer's original personalized details, such as menu and stored memory, such as phone books, or even just program a unit with basic user information, such as language selection. Z8 telephones use Motorola Phone Tools synchronization software to effect a personality transfer.

Identification

Each Motorola GSM device is labeled with a variety of identifying numbers. The following information describes the current identifying labels.

Mechanical Serial Number (MSN)

The Mechanical Serial Number (MSN) is an individual unit identity number and remains with the unit throughout the life of the unit.

The MSN can be used to log and track a unit on Motorola's Service Center Database. The MSN is divided into 4 sections, as shown in Figure 16.

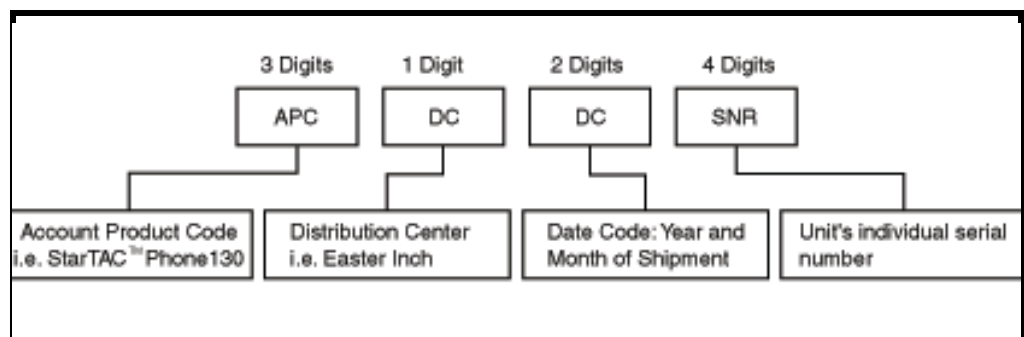

000807a

Figure 16. MSN Label Breakdown

International Mobile Station Equipment Identity (IMEI)

The International Mobile station Equipment Identity (IMEI) number is an individual number unique to the PCB and is stored within the unit's memory.

The IMEI uniquely identifies an individual mobile station and thereby provides a means for controlling access to GSM networks based on mobile station types or individual units. The full IMEI structure is listed in Table 2.

Table 2. IMEI Number Breakdown

TAC	Serial Number	Check Digit
NNXXXXXX	ZZZZZZ	A

Where

TAC Type Allocation Code, formerly known as Type Approval Code

NN Reporting body identifier

XXXXXX Type Identifier

ZZZZZZ Individual unit serial number

A Phase 1 = 0.

Phase 2 = check digit defined as a function of all other IMEI digits

Other label number configurations present are:

- **TRANSCIVER NUMBER:** Identifies the product type. Normally the SWF number. (i.e. V100).
- **PACKAGE NUMBER:** Identifies the equipment type, mode, and language in which the product is shipped.

Troubleshooting

Manual Test Mode

Motorola Z8 telephones are equipped with a manual test mode capability. This allows service personnel to verify functionality and perform fault isolation by entering keypad commands.

To enter the manual test command mode, a GSM / DCS test SIM must be used.

1. Turn the phone OFF.
2. Remove the battery as described in the procedures.
3. Remove the customer's SIM card from the phone as described in the procedures.
4. Insert the test SIM into the SIM slot.
5. Replace the battery as described in the procedures.
6. Turn the phone ON.

Troubleshooting Chart

Table 3. : Level 1 and 2 Troubleshooting Chart

SYMPTOM	PROBABLE CAUSE	VERIFICATION AND REMEDY
1. Telephone will not turn on or stay on.	a) Battery either discharged or defective.	Measure battery voltage across a 50 ohm (>1 Watt) load. If the battery voltage is <3.25 Vdc, recharge the battery using the appropriate battery charger. If the battery will not recharge, replace the battery. If battery is not at fault, proceed to b.
	b) Battery connectors open or misaligned.	Visually inspect the battery connectors on both the battery and the telephone. Realign and, if necessary, either replace the battery or refer to a Level 3 Service Center for the battery connector replacement. If battery connectors are not at fault, proceed to c.
	c) Transceiver board assembly defective.	Forward to an authorized level 3 service center.
	d) keyboard assembly failure.	Replace the keyboard assembly. Temporarily connect a +3.6 Vdc supply to the battery connectors. Press and hold the PWR button. If unit turns on and stays on, disconnect the dc power source and reassemble with the new keyboard assembly.
2. Telephone exhibits poor reception or erratic operation, such as calls frequently dropping or weak or distorted audio.	a) Antenna assembly defective.	Check to make sure that the antenna pin is properly connected to the transceiver board assembly. If connected properly, substitute a known good antenna. If the fault is still present, proceed to b.
	b) Transceiver board assembly defective.	Forward to an authorized level 3 service center.

Table 3. : Level 1 and 2 Troubleshooting Chart (Continued)

SYMPTOM	PROBABLE CAUSE	VERIFICATION AND REMEDY
3. Display is erratic, or provides partial or no display.	a) Transceiver board connections faulty.	Remove rear chassis assembly from unit, check general condition of flexible printed cable (flex). If the flex is good, check that the flex connector is fully pressed down. If not, check connector to transceiver board connections. If faulty connector, replace the transceiver board assembly. If connector is not at fault, proceed to b.
	c) Transceiver board assembly defective.	Forward to an authorized level 3 service center.
4. Incoming call alert transducer audio distorted or volume is too low.	Faulty transceiver board assembly.	Replace the transceiver board assembly (refer to 1c). Verify that the fault has been cleared and reassemble the unit with the new transceiver board assembly.
5. Telephone transmit audio is weak. (usually indicated by called parties complaining of difficulty in hearing voice).	a) microphone obstructed by user while holding the phone	Verify transmit audio quality. If transmit audio quality is still weak and microphone is not obstructed, proceed to b.
	b) Microphone defective.	Replace the microphone as described in the procedures. If fault is not cleared, proceed to c.
	c) Transceiver board defective.	Forward to an authorized level 3 service center.
6. Receive audio from earpiece speaker is weak or distorted.	a) Connections to or from transceiver board assembly defective.	Gain access to the transceiver board assembly as described in the procedures. Check flex and the flex connector to the transceiver board assembly. If flex connector is at fault, proceed to d. If connection is not at fault, proceed to b.
	b) Antenna assembly defective.	Check to make sure the antenna is installed correctly. If the antenna is installed correctly, substitute a known good antenna assembly. If this does not clear the fault, reinstall the original antenna assembly and proceed to d.
	c) Transceiver board assembly defective.	Forward to an authorized level 3 service center.
7. Telephone will not recognize or accept SIM.	a) SIM defective.	Check the SIM contacts for dirt. Clean if necessary and check if fault has been cleared. If the contacts are clean, insert a known good SIM into the telephone. Power up the unit and confirm that the SIM has been accepted. If the fault no longer exists, replace the defective SIM. If the SIM is not at fault, proceed to b.
	b) Transceiver board assembly defective.	Forward to an authorized level 3 service center.
8. Vibrator feature not functioning.	Transceiver board assembly defective.	Forward to an authorized level 3 service center.
9. Internal Charger not working.	Faulty charger circuit on transceiver board assembly.	Test a selection of batteries in the rear pocket of the desktop charger. Check LED display for the charging indications. If these are charging properly, then the internal charger is at fault. Replace the transceiver board assembly (refer to 1c). Verify that the fault has been cleared and reassemble the unit with the new transceiver board assembly.

Table 3. : Level 1 and 2 Troubleshooting Chart (Continued)

SYMPTOM	PROBABLE CAUSE	VERIFICATION AND REMEDY
10. Real Time Clock resetting when standard battery is removed.	Lithium button cell in the display board may be depleted.	Refer service to a Level 3 service center for replacement.
11. No or weak audio when using headset.	a) Headset not fully pushed home.	Ensure the headset plug is fully seated in the jack socket. If fault not cleared, proceed to b.
	b) Faulty jack socket on transceiver board assembly.	Replace the transceiver board assembly (refer to 1c). Verify that the fault has been cleared and reassemble the unit with the new transceiver board assembly.

Programming: Software Upgrade and Flexing

Contact your local technical support engineer for information about equipment and procedures for flashing and flexing.

Exploded View Diagram

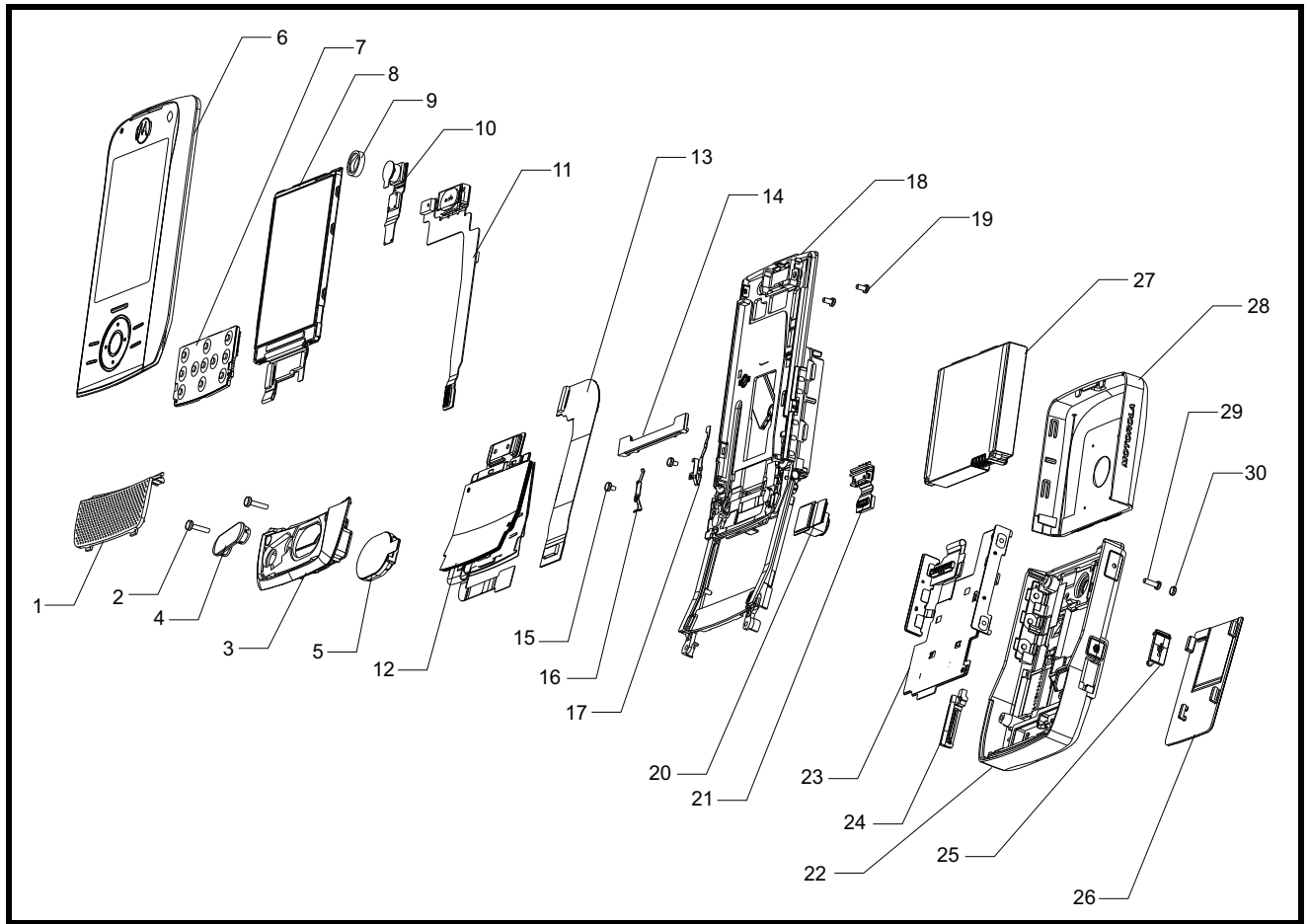

Figure 17. Exploded View Diagram

v459714

Exploded View Parts List

Part numbers are only provided as a reference. Contact your local Motorola parts organization for current part number information.

Table 4. Exploded View Parts List

Item	Part Number	Description	Item	Part Number	Description
1	0103582P01	Cover Alert Speaker	19	0303529E03	Screw M1.4x2.5mm
2	0303529E05	Screw K15x8.5mm	20	0103560E01 1503608E01	MPXL Camera MPXL Camera grommet
3	0103597E02	Endo Audio Assy	21	0103613P01	Battery assembly flex
4	0503578C18	RF grommet	22	0103515P02	Rear housing assembly
5	0103564P01	Alert speaker	23	0103698E02	Expansion PCB assembly
6		Front housing assembly	24	0503578C11	Transflash card grommet
7	0103580P01	Keyboard navigation	25	0503578C10	USB grommet
8	7271449E04	Display assembly	26	CFHN9093A	SIM Card Bezel
9	1503579B14	VGA camera grommet	27	SNN5792A	Battery
10	0103562E01	VGA camera	28	CFHN9089A	Battery door
11	0103666E04	Flex slider module	29	0303529E04	Screw M1.6 x 4.5mm
12	0103509P02	Keyboard assembly	30	0503578C22	Screw cover
13	0103664E02	Flex dynamic	31	1503579B13	Microphone grommet
14	0703577C39	Bridge support assembly			
15	0371235E01	Screw M1.2 x1.75mm			
16	4203641D10	Grounding clip left			
17	4203641D11	Grounding clip right			
18	0103535E02	Slider assembly			

Accessories

Table 5. Accessories

Accessory Description	Kit Number
Audio and Media	
H3 Bluetooth Headset Dark Pearl Grey	SYN1507
H500 Bluetooth headset Black Softtouch	SYN1374
H500 Bluetooth Headset Hot Pink	SYN1525
H500 Bluetooth Headset iPod Blue	SYN1523
H500 Bluetooth Headset iPod Gold	SYN1524
H500 Bluetooth Headset Spa Blue	SYN1527
H500 Bluetooth Headset White	SYN1526
H500 Gloss Black	SYN1375
H500 Nickel Japan	SYN1441
H500 Pink	SYN1436
Headset Mono One Touch w/ Send-End (EMU)	SYN0896
Headset Stereo 3.5mm	SYN1302
Bluetooth Stereo Transceiver DC800	SYN1001
RAZR H3 Black	SYN1437
RAZR H3 Silver	SYN1438
Stereo Headset - EMU	SYN1301
H350 BT Headset Black	SYN1439
JBL Black On Tour Portable Speaker	SYN1451
JBL On Tour Mobile European Kit	OnTourMBBLKE
JBL On Tour Mobile portable speaker US Kit	OnTourMBBLK
JBL On Tour Mobile speaker PRC kit	CH1414A
JBL On Tour Mobile speaker UK kit	OnTourMBBLKU
S805 DJ Headset - Bluetooth - Music and Telephony	SYN1673
H500 Bluetooth Headset Fire Red	SYN1667
H500 Bluetooth Headset Celery	SYN1732
H500 Bluetooth Headset Pumpkin	SYN1733
H500 Bluetooth Headset Steel Teal	SYN1734
H500 Bluetooth Headset Oi	SYN1735
H3 Bluetooth Headset Cherry Red	SYN1736
H350 Bluetooth Headset Sapphire Blue	SYN1738
H350 Bluetooth Headset Silver Sail	SYN1764
H350 Bluetooth Headset Dark Pearl Grey	SYN1763
H350 Bluetooth Headset Silver Quartz	SYN1765
D&G Gold H700	SYN1769
Blue/Black Cingular Only H700	SYN1508
Black H700 (not available in North America)	SYN1509
Blue H700 (Verizon only in North America)	SYN1618
Bluetooth Module (Stereo Music and Telephony)	SYN1447

Table 5. Accessories (Continued)

Accessory Description	Kit Number
Bluetooth Stereo Headset & Controller S705	SYN1711
Bluetooth Headset - HS850 (Refresh - Black)	SYN1107
Bluetooth Headset - HS850 (Refresh - Blue)	SYN1226
Bluetooth Headset (Pearl Dark Gray) - H300	SYN1297
Bluetooth Headset (Pink) - H300	SYN1417
Bluetooth Headset (Pure White) - H300	SYN1416
Bluetooth Headset - H605	SYN1303
Bluetooth Mono Headset, Nickel- H500	SYN1290
Bluetooth Stereo Headset HT820	SYN0948
Bluetooth Headset - H700 (silver)	SYN1311
Automotive	
Bluetooth Car Kit - Asia/Americas	S9642
Bluetooth Car Kit - Euro	S9643
Bluetooth Car Kit - HF850	98675H
Bluetooth Car Kit - IHF1000 - Americas/Asia	98676J
Bluetooth Car Kit - IHF1000 - EMEA	CFLN1232AB
BT Pro-Install Carkit IHF1000r	98676K
T605 Pro Install Bluetooth Carkit	SYN1782A
Bluetooth Car Kit - High Tier, T505	SYN1717
Bluetooth Car Kit - Mid Tier, T305	SYN1716
Data and Enterprise	
1GB microSD card & Mot SD adapter	SYN1406
128MB microSD card & Mot SD adapter	SYN1403
Bluetooth TXTR Keyboard (silver)	SYN1391
2GB microSD card & Mot SD adapter	SYN1407
SD 128MB card	SYN1659
SD 1GB card	SYN1584
SD 256MB card	SYN1589
SD 2GB card	SYN1585
SD 512MB card	SYN1583
SD 64MB card	SYN1658
SD 4GB	SYN1586
256MB microSD card & Mot SD adapter	SYN1404
32MB microSD card & Mot SD adapter	SYN1401
512MB microSD card & Mot SD adapter	SYN1405
64MB microSD card & Mot SD adapter	SYN1402
Bluetooth Class 1 USB Adapter PC850	SYN1244
Digital Accessories	
Data Cable Mini USB/USB/Serial	SKN6371
Mobile Phone Tools	Region-specific

Table 5. Accessories (Continued)

Accessory Description	Kit Number
Modules	
Reverb (Oakley Stereo Bluetooth Eyewear - BLK)	SYN1552
Reverb (Oakley Stereo Bluetooth Eyewear - WHT)	SYN1553
REVERB (Oakley Stereo Bluetooth Eyewear Br. Sm.)	SYN1554
Bluetooth Helmet Adapter (Mage) - HS830	SYN0996
Oakley RAZRWIRE (Mercury: NA) - H7	98679H
Oakley RAZRWIRE (Pewter/Black: NA) - H7	98677H
Oakley RAZRWIRE (Platinum/Rootbeer: NA) - H7	98678H
Power and Personalization	
Battery BC70 (SC6) Li-Ion 1000 mAh	SNN5769
Charger Adapter - Aust/NZ Plug	SYN8127
Charger Adapter - Euro Plug	SYN7456
Charger Adapter - UK Plug	SYN7455
Charger Adapter EMU/EMU (Y-cable)	SKN6222
Travel Charger EMU Mid-Rate Switcher - Argentina	SPN5192
Travel Charger EMU Mid-Rate Switcher - Australia	SPN5193
Travel Charger EMU Mid-Rate Switcher - BRAZIL	SPN5187
Travel Charger EMU Mid-Rate Switcher - EURO	SPN5189
Travel Charger EMU Mid-Rate Switcher - INDIA	SPN5194
Travel Charger EMU Mid-Rate Switcher - MEXICO	SPN5186
Travel Charger EMU Mid-Rate Switcher - PRC	SPN5188
Travel Charger EMU Mid-Rate Switcher - TWN	SPN5216
Travel Charger EMU Mid-Rate Switcher - UK/HK	SPN5190
Travel Charger EMU Mid-Rate Switcher - US ENG	SPN5185
Travel Charger EMU Rapid Switcher - Argentina	SPN5197
Travel Charger EMU Rapid Switcher - BRAZIL	SPN5196
Travel Charger EMU Rapid Switcher - HK	SPN5199
Travel Charger EMU Rapid Switcher - MEXICO	SPN5200
Travel Charger EMU Rapid Switcher - PRC	SPN5198
Travel Charger EMU Rapid Switcher - US	SPN5202
Travel Charger EMU Rapid TWN	SPN5270
Vehicle Power Adapter EMU - VC700	SYN0847
Battery-Only-Charger for SC batteries, HongKong plug	SYN1486A
Battery-Only-Charger for SC batteries, PRC plug	SYN1492A
Battery-Only-Charger for SC batteries, Taiwan plug	SYN1485
Battery-Only-Charger for SC batteries, US/Euro plug	SYN1484
BATTERY-ONLY-CHARGER FOR KC/BK BATTERIES US PLG	SYN1699A
Battery-Only-Charger, KC (BK) battery, PRC plug	SYN1700
P320 desktop BOC (battery-only-charge), platform, EMU	SPN5394

Table 5. Accessories (Continued)

Accessory Description	Kit Number
P320 desktop BOC, platform, EMU, Chinese label	SPN5395
Travel Charger EMU Mid-Rate Switcher - JAPAN	SPN5274
Travel Charger EMU Rapid Switcher - Japan	SPN5275

A

antenna, removing and replacing 23

B

battery

charge indicator 11

function 11

removing 13

battery housing

removing 13

Bluetooth indicator 10

C

caller ID 8

calls indicator 10

Canadian Interference-Causing Equipment regulations 1

changes

product 1

conventions 3

copyrights

computer software 2

D

disassembly 13

E

exploded view diagram 29

exploded view parts list 30

F

FCC rules 1

features

caller ID 8

text entry 8

I

identification 24

international mobile station equipment identity 25

mechanical serial number 24

product 1

IMEI 25

L

LCD 11

liquid crystal display (LCD) 11

M

manual test mode 26

memory card, removing and replacing 16

message indicator 10

MSN 24

N

names

product 1

network indicator 10

O

operation 9

battery 11

controls, indicators, and I/O connectors 9

LCD 11

menu navigation 11

P

part numbers

accessories 31

parts

exploded view diagram 29

exploded view parts list 30

product

changes 1

identification 1

names 1

product overview 7

features 7

R

rear housing

removing 17

regulatory agency compliance 1

removing

antenna 23

battery 11, 13

battery housing 13

memory card 16

rear housing 17

SIM 15

- transceiver board 17
- replacement parts
 - contact information 4
- replacing
 - antenna 23
 - battery 13
 - memory card 16
 - rear housing 17
 - SIM 15
 - transceiver board 17
- roam indicator 10

S

- serial number
 - mechanical 24
- service manual
 - about 2
 - revisions 3
 - scope 2
- service policy 3
 - customer support 3
 - out of box failure 3
 - product support 3
- service procedure
 - ordering replacement parts 4
- shut down
 - upon battery removal 11
- signal strength indicator 10
- SIM card 24
 - personality transfer 24
 - replacing 15
- SIM, removing and replacing 15
- sound mode indicator 11
- specifications 5
- status indicators 10
- support
 - customer 3
 - product 3

T

- text entry 8
- tools and test equipment 12
- troubleshooting 26
 - manual test mode 26

V

- voicemail message indicator 10

W

- warranty service 3



MOTOROLA