

Revision 1.0: Initial Drawing

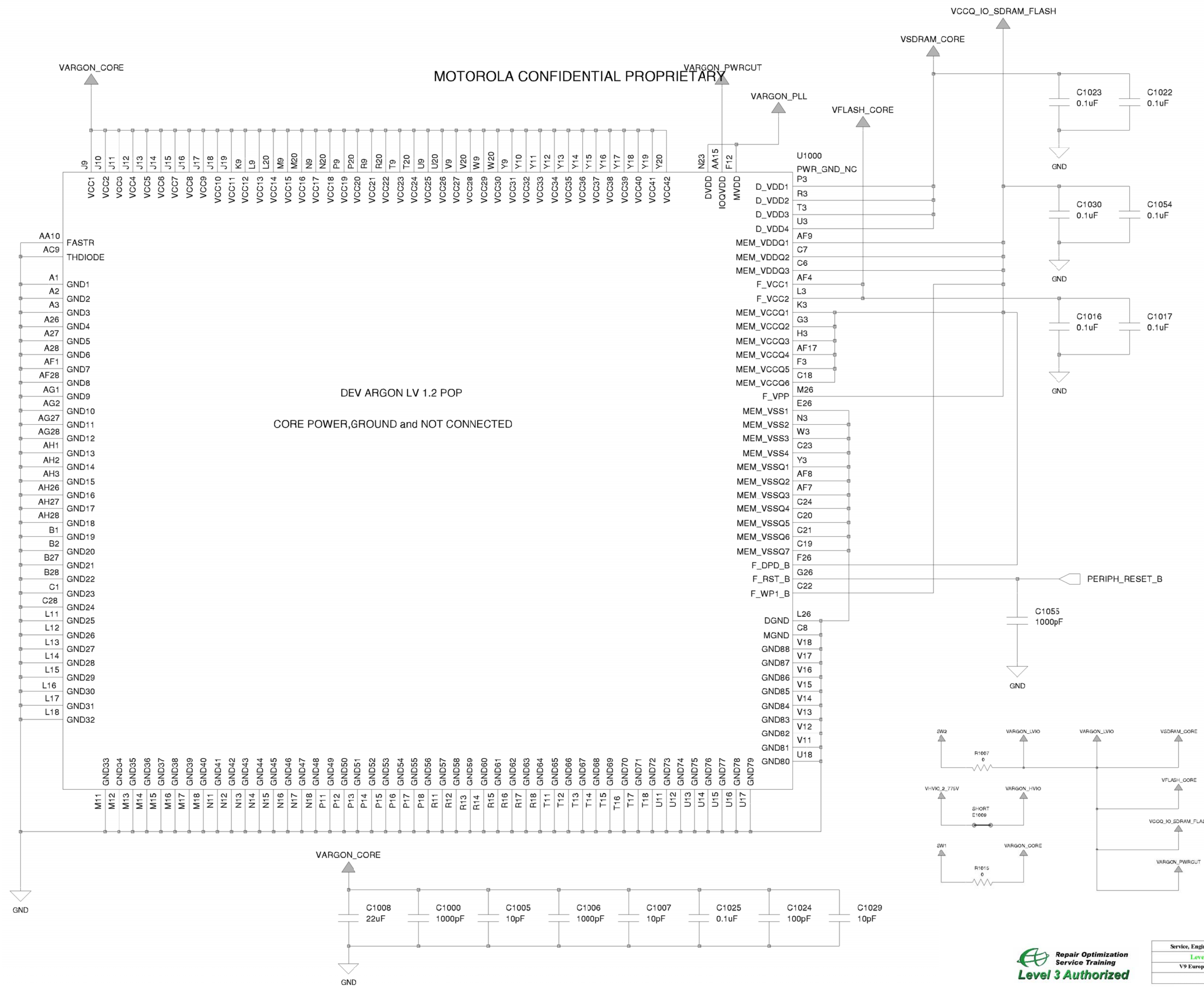

Service, Engineering & Optimization	2008.09.30
Level 3 Schematics	Rev. 1.0
V9 Europe with ORNAND Memory	8471274E01
	Page 2 of 16



MOTOROLA CONFIDENTIAL PROPRIETARY

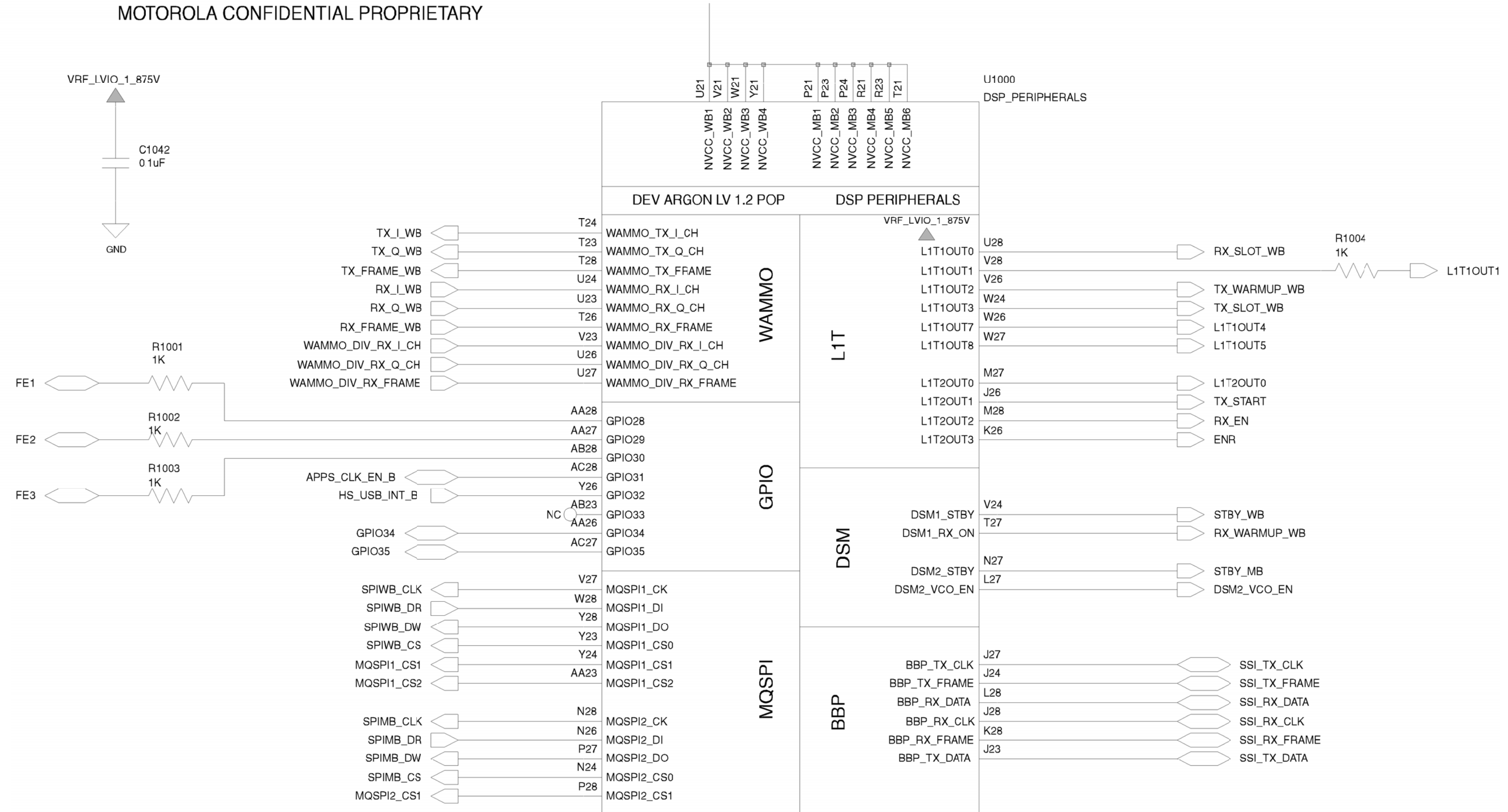

V9 Europe with ORNAND_5471274E01

Revision 1.0: Initial Drawing

Repair Optimization
Service Training
Level 3 Authorized

Service, Engineering & Optimization	2008.09.30
Level 3 Schematics	Rev. 1.0
V9 Europe with ORNAND Memory	8471274E01
	Page 4 of 16

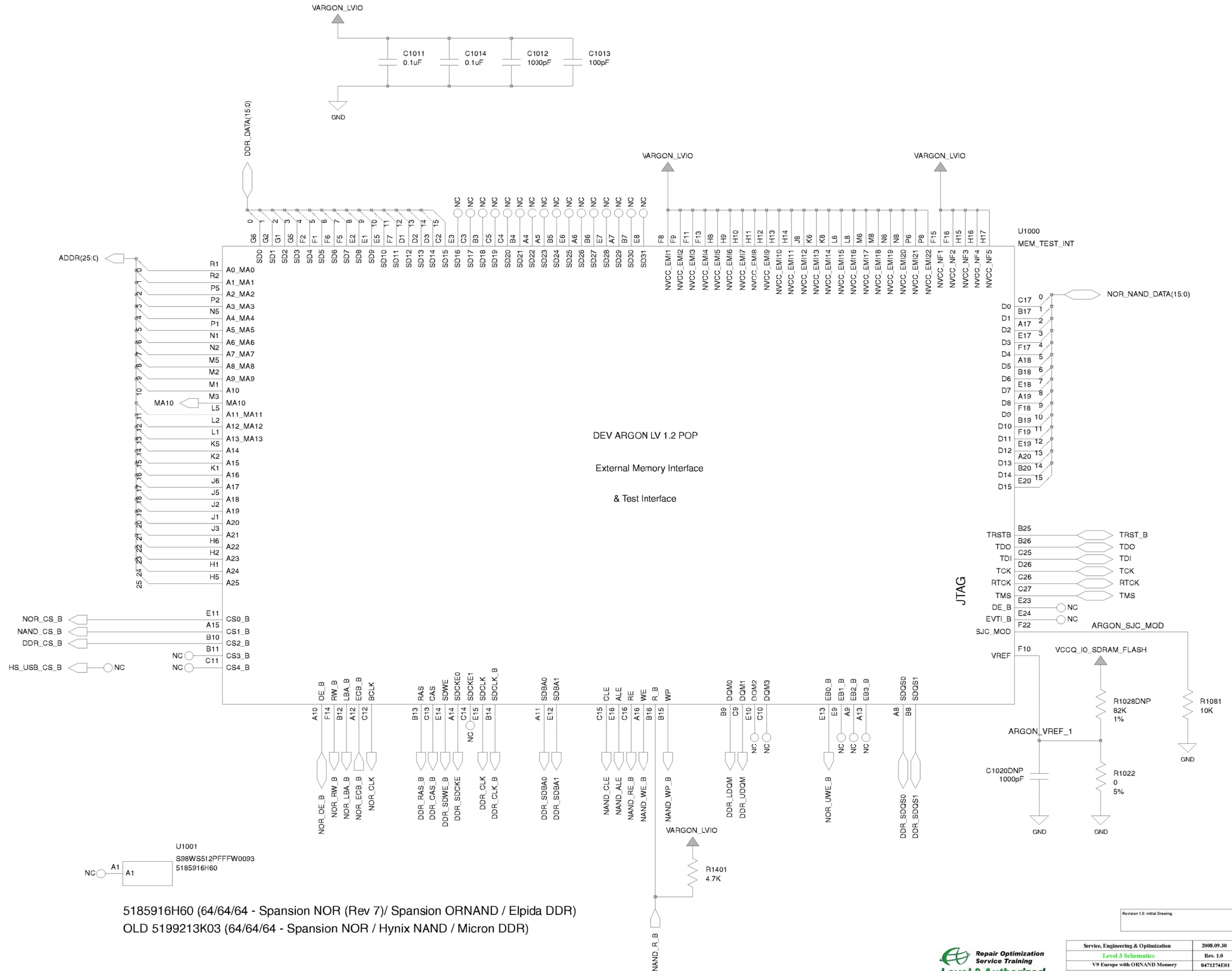

5185916H60 (64/64/64 - Spansion NOR (Rev 7)/ Spansion ORNAND / Elpida DDR)
 OLD 5199213K03 (64/64/64 - Spansion NOR / Hynix NAND / Micron DDR)

Revision 1.0: Initial Drawing

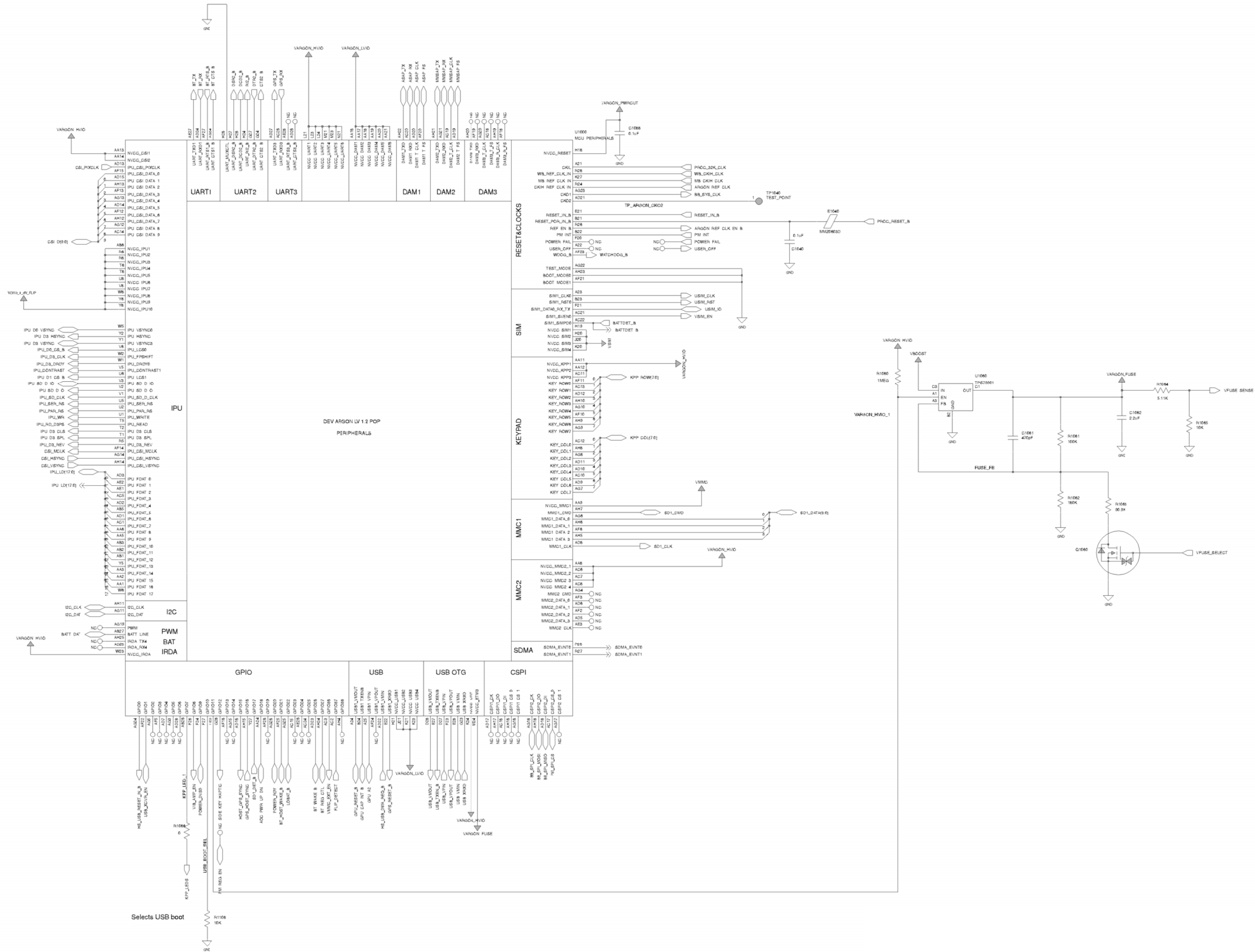
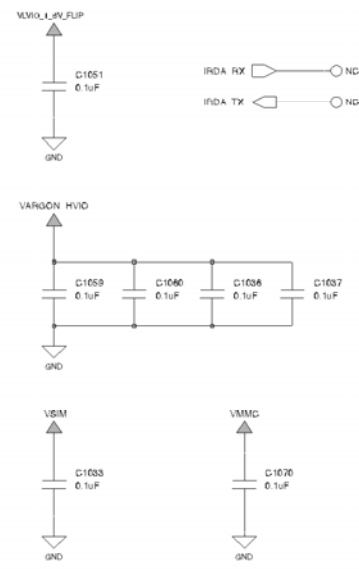

Revision 1.0: Initial Drawing

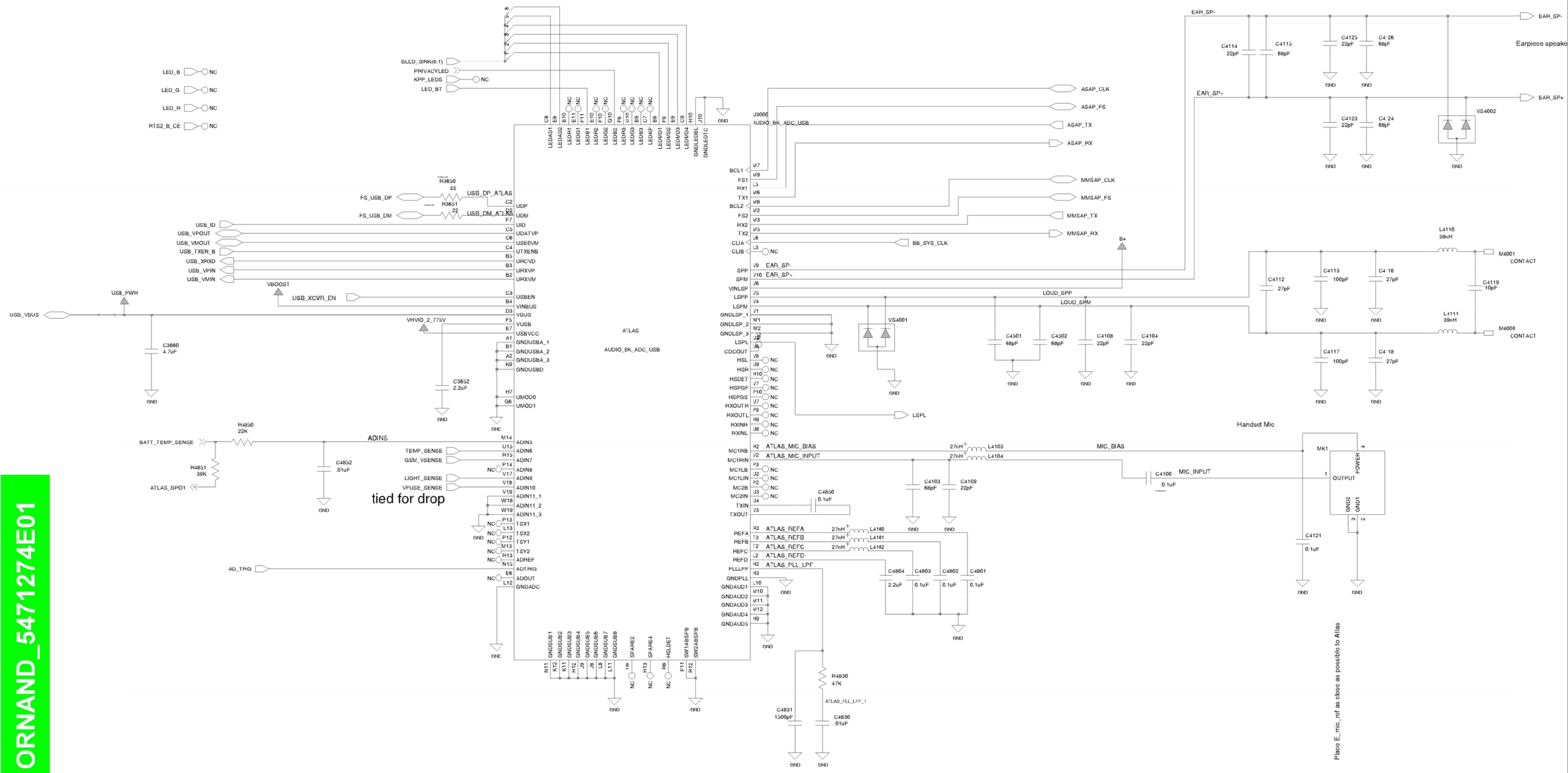

Place E_mic_ref as close as possible to Atlas

Revision 1.0: Initial Drawing

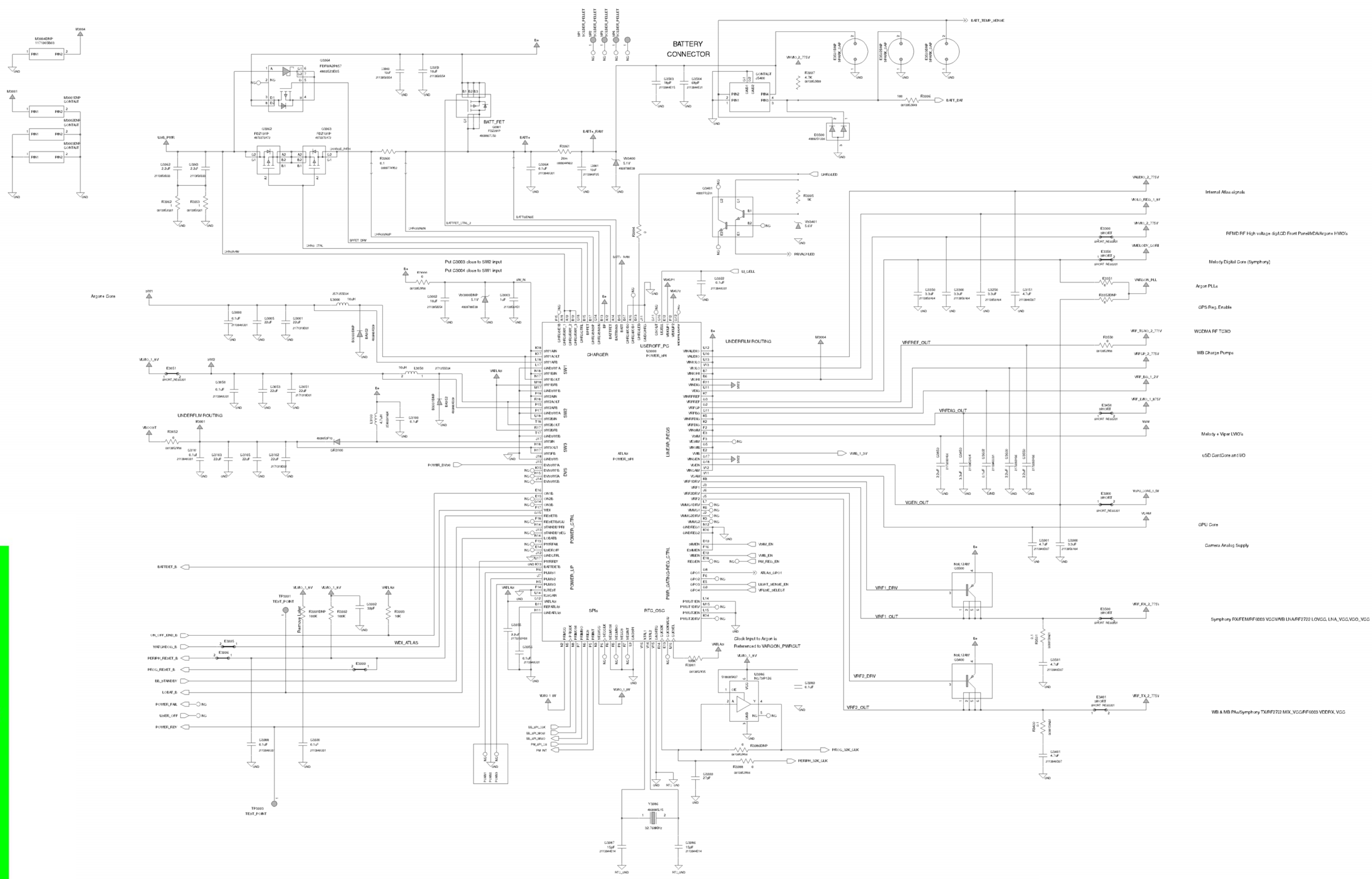

Revision 1.0: Initial Drawing



Service, Engineering & Optimization	2008.09.30
Level 3 Schematics	Rev. 1.0
V9 Europe with ORNAND Memory	8471274E01
	Page 8 of 16

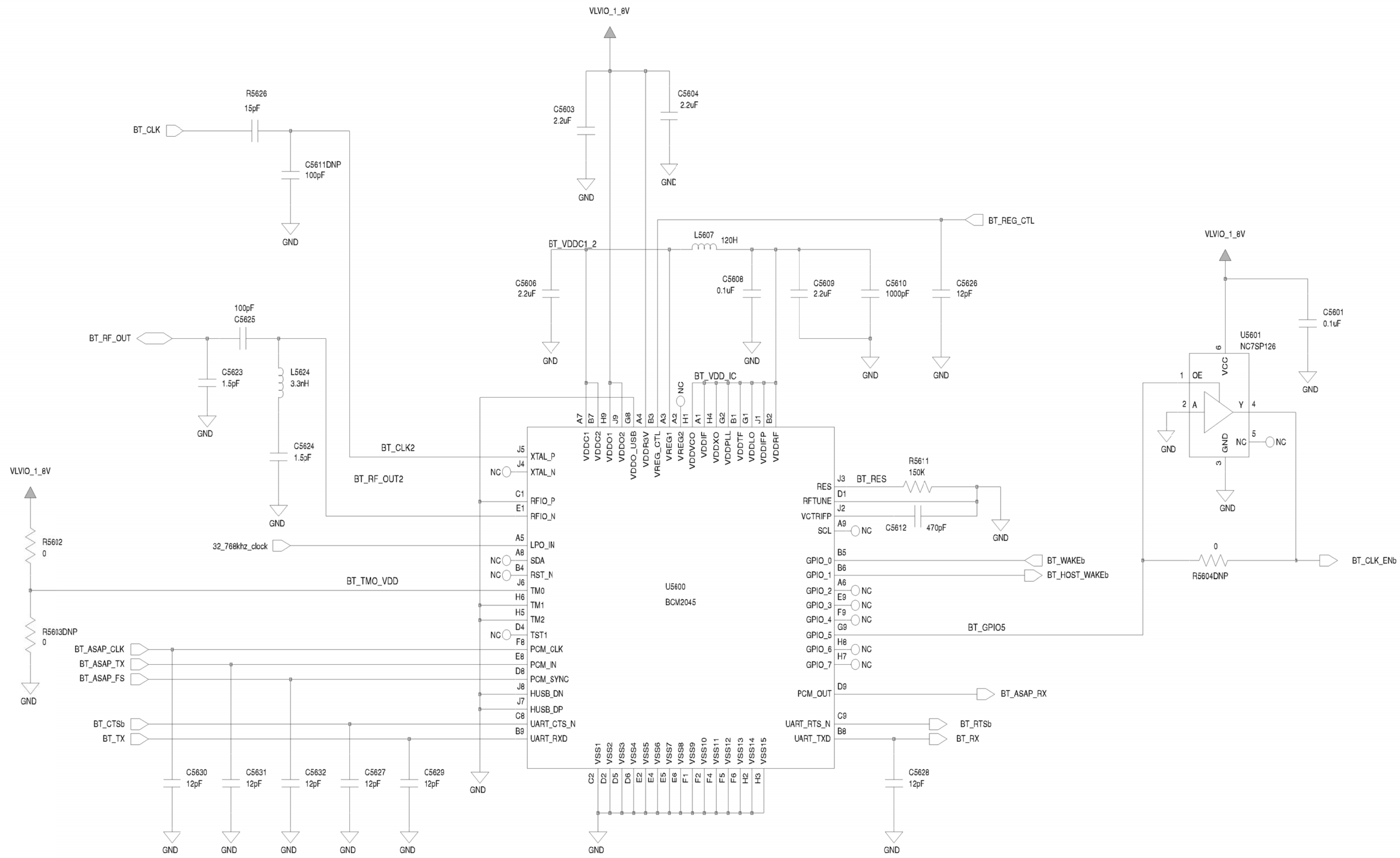

Revision 1.0: Initial Drawing

MOTOROLA INTERNAL USE ONLY

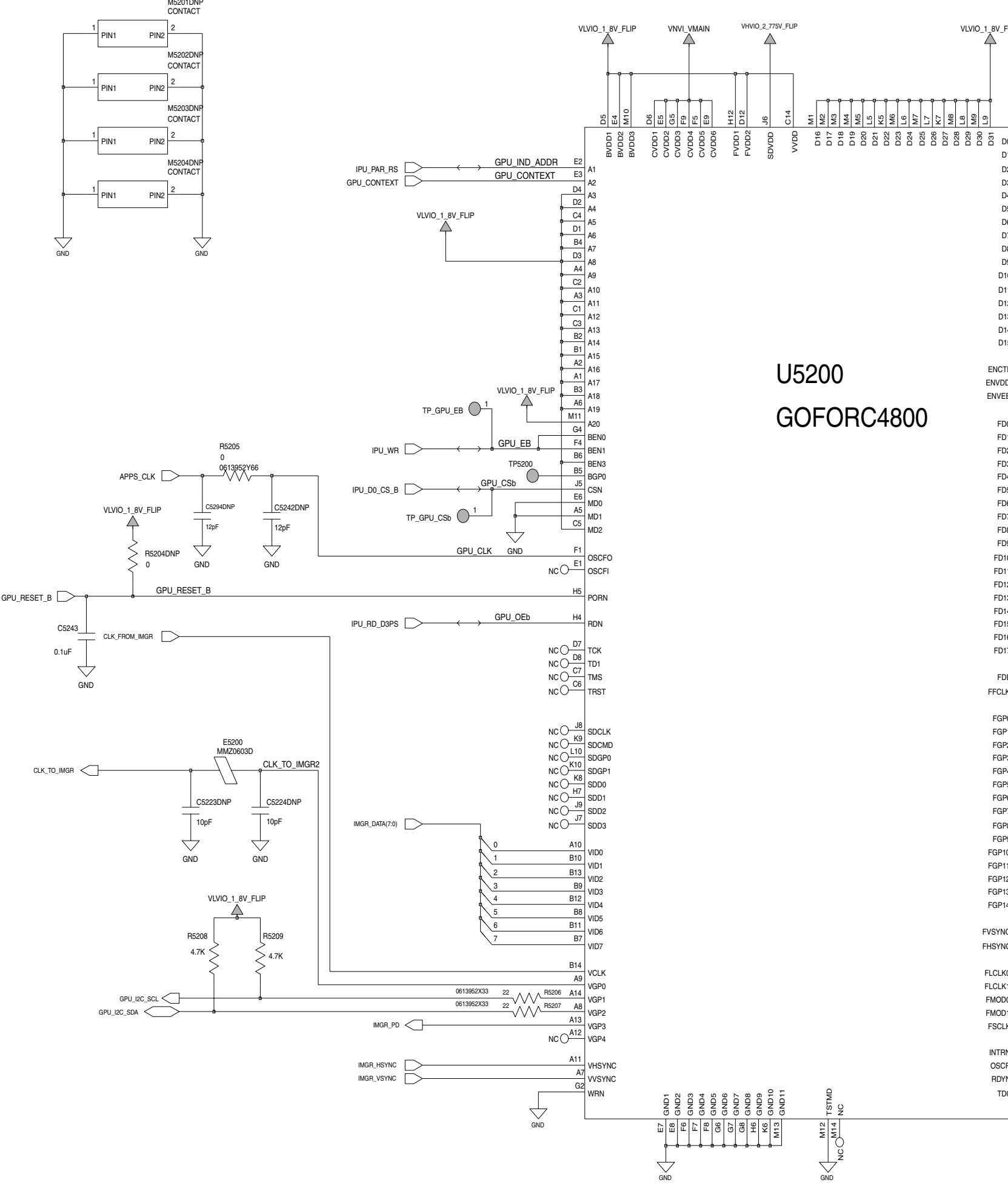
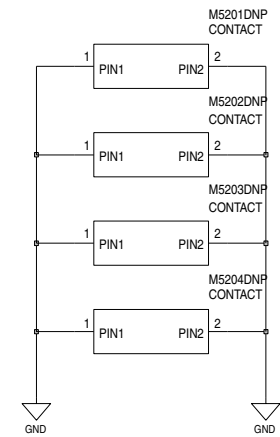

U5200
GOFORC4800

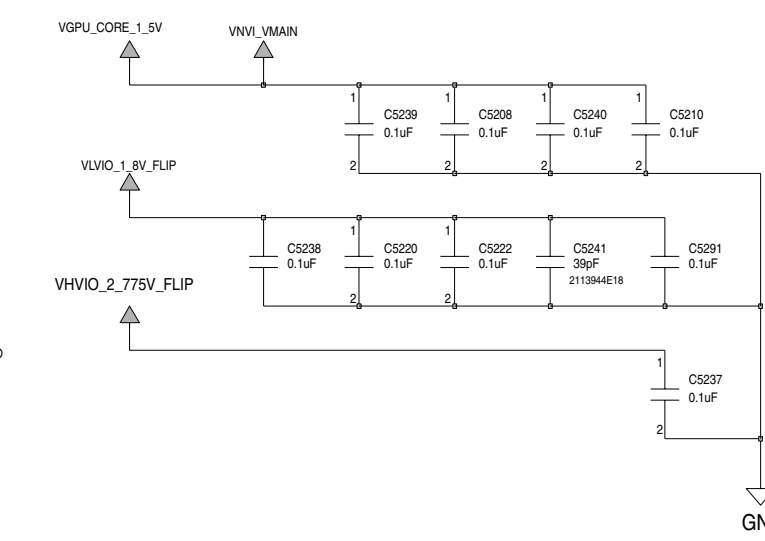
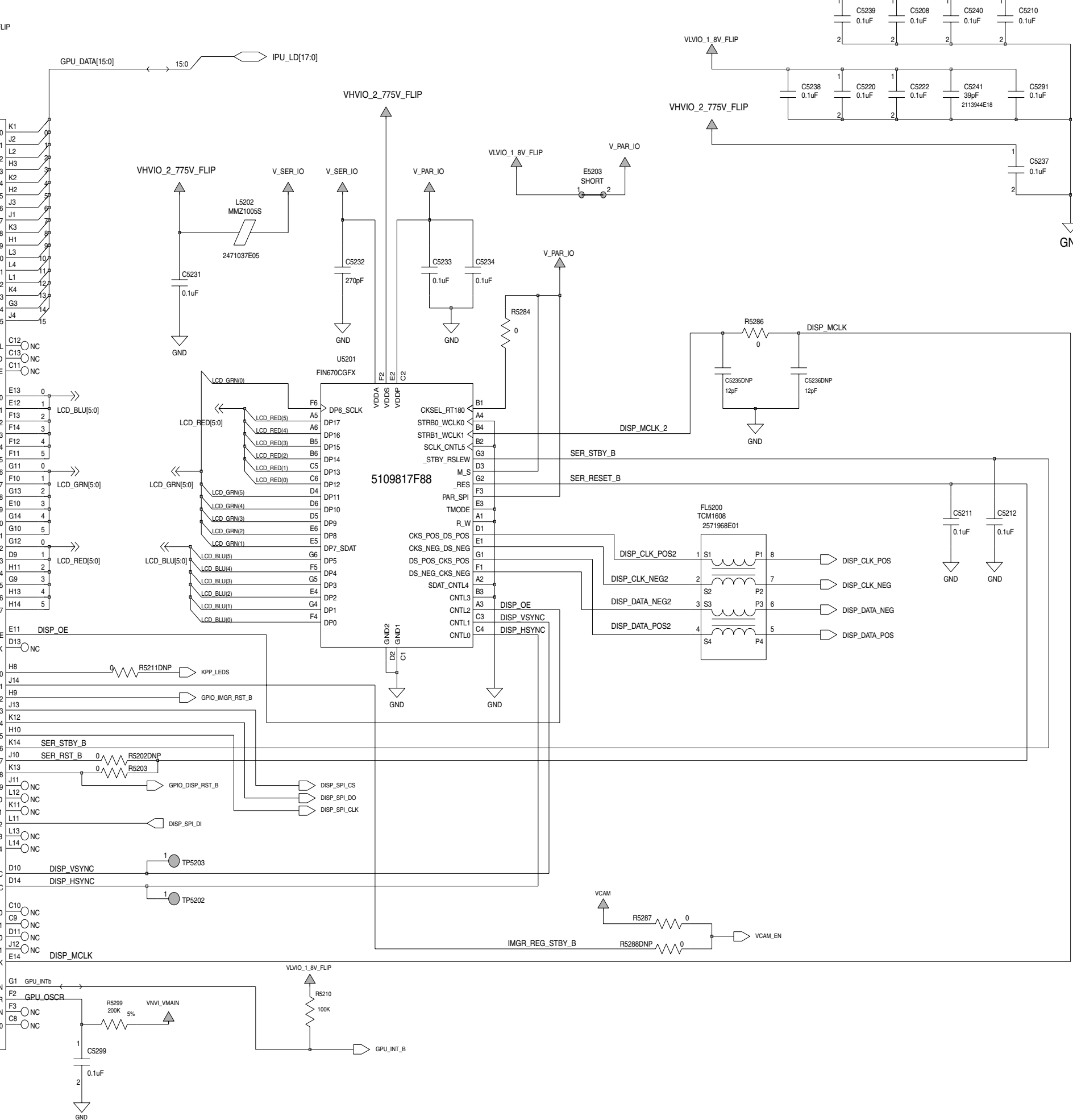

V9 Europe with ORNAND_5471274E01

Revision 1.0: Initial Drawing

Repair Optimization
Service Training
Level 3 Authorized

Service, Engineering & Optimization	2008.09.30
Level 3 Schematics	Rev. 1.0
V9 Europe with ORNAND Memory	8471274E01
	Page 11 of 16

EMU CONNECTOR

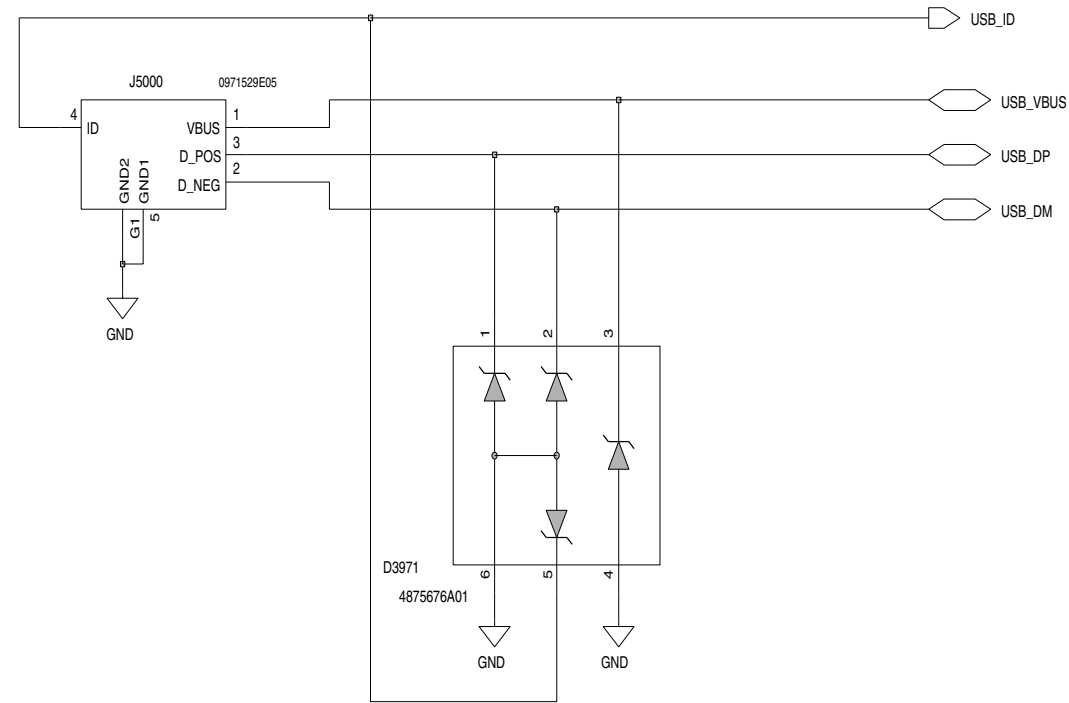

USIM

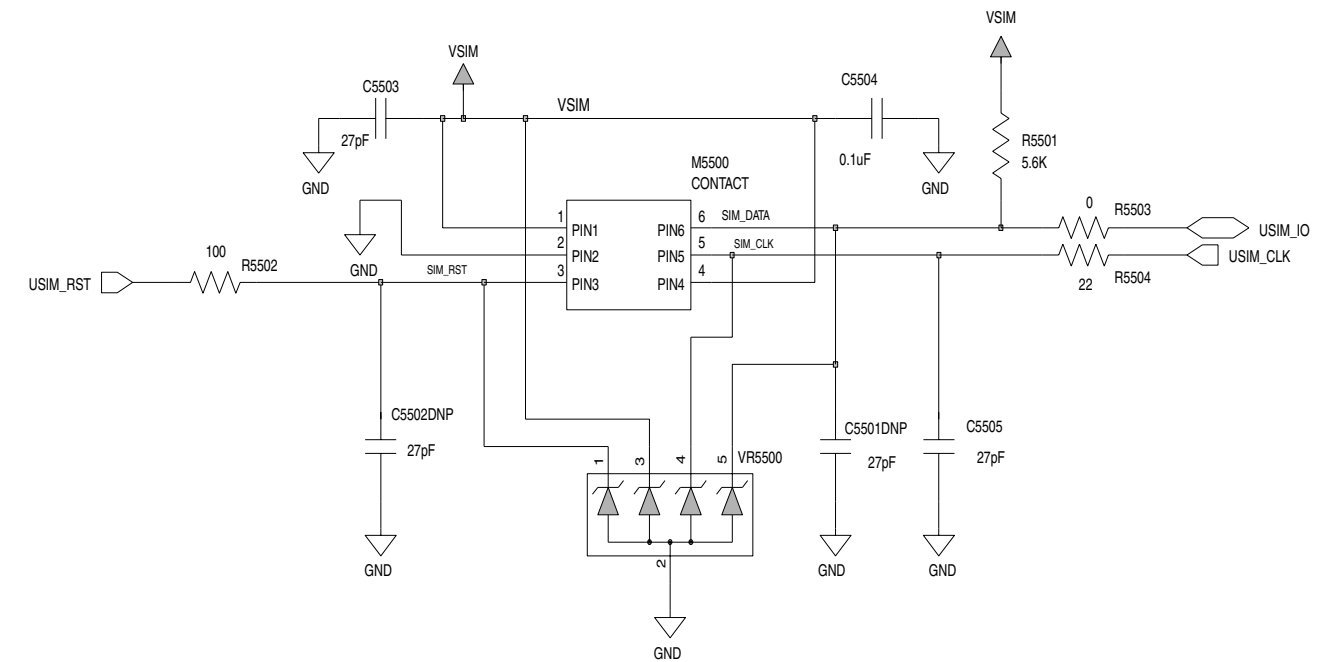

JTAG/DAI

12-pin JTAG connector

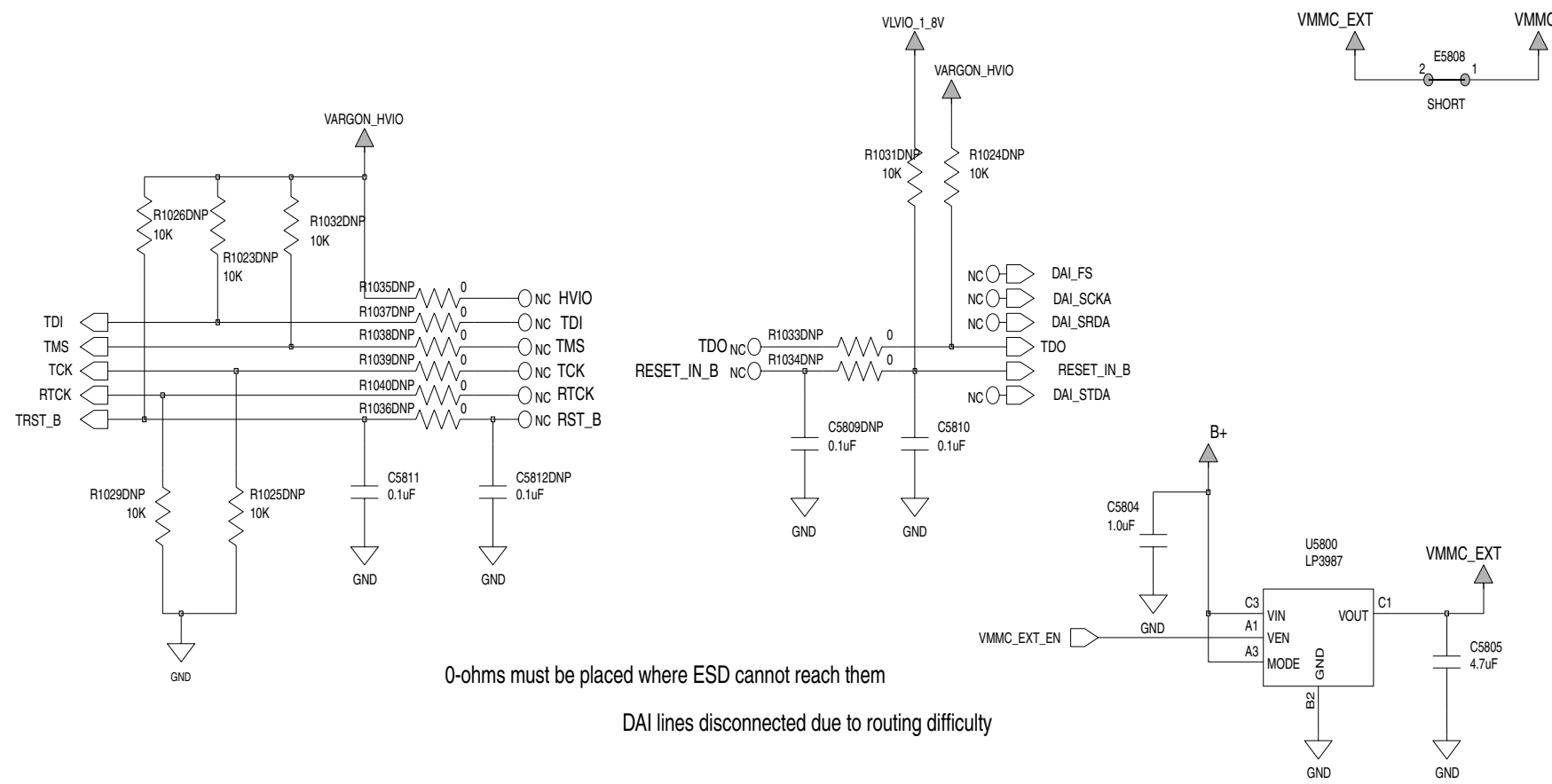

0-ohms must be placed where ESD cannot reach them

DAI lines disconnected due to routing difficulty

If JTAG is placed, place 0-ohms, pull-ups/downs. DNP C5810 and C5811

If JTAG is NOT placed, DNP 0-ohms, DNP pull-ups/downs, place C5809, C5810, C5811, C5812

TRANSFLASH

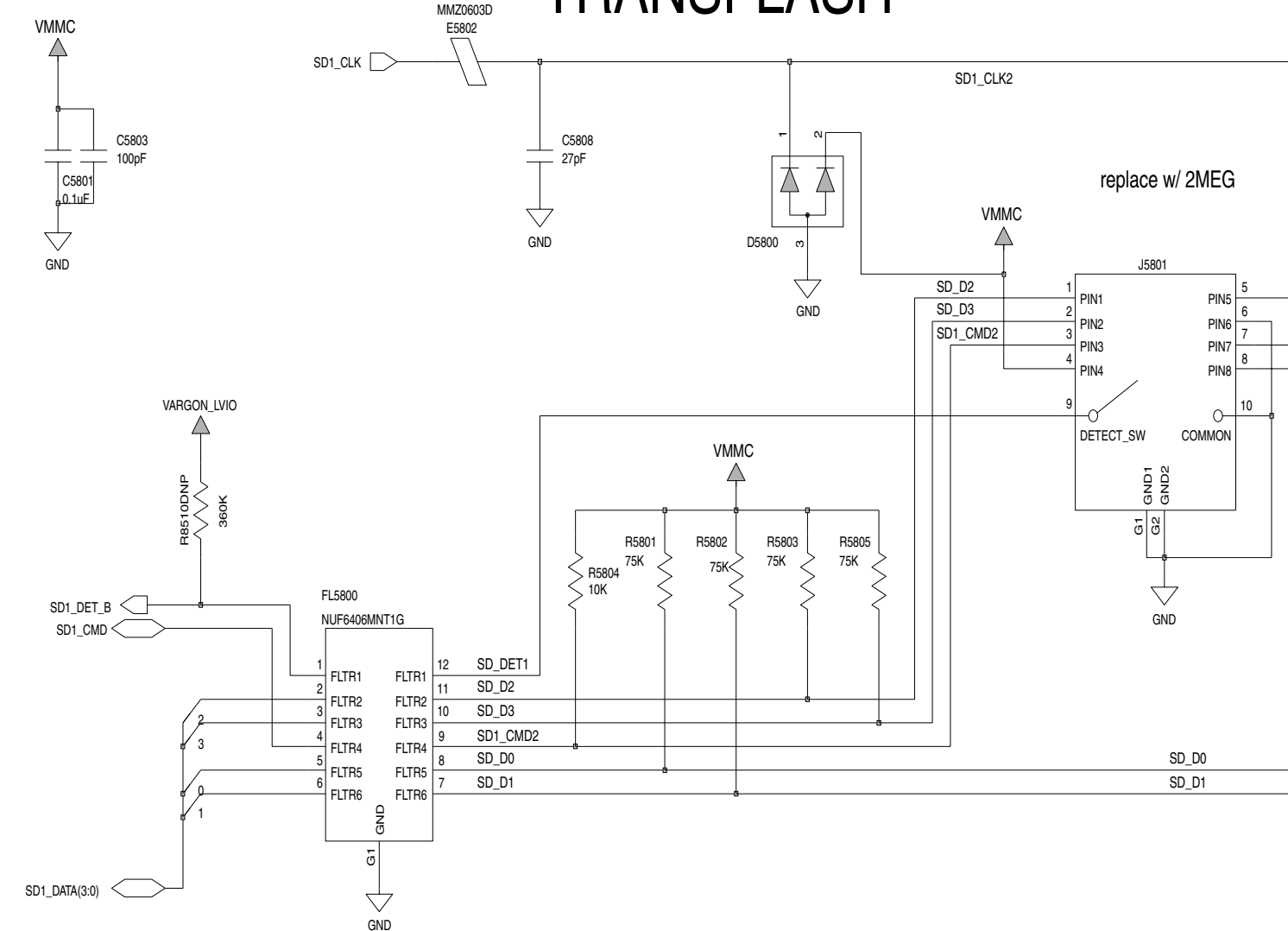

replace w/ 2MEG

Revision 1.0: Initial Drawing

V9 Europe with ORNAND_5471274E01

V9 Europe with ORNAND_5471274E01

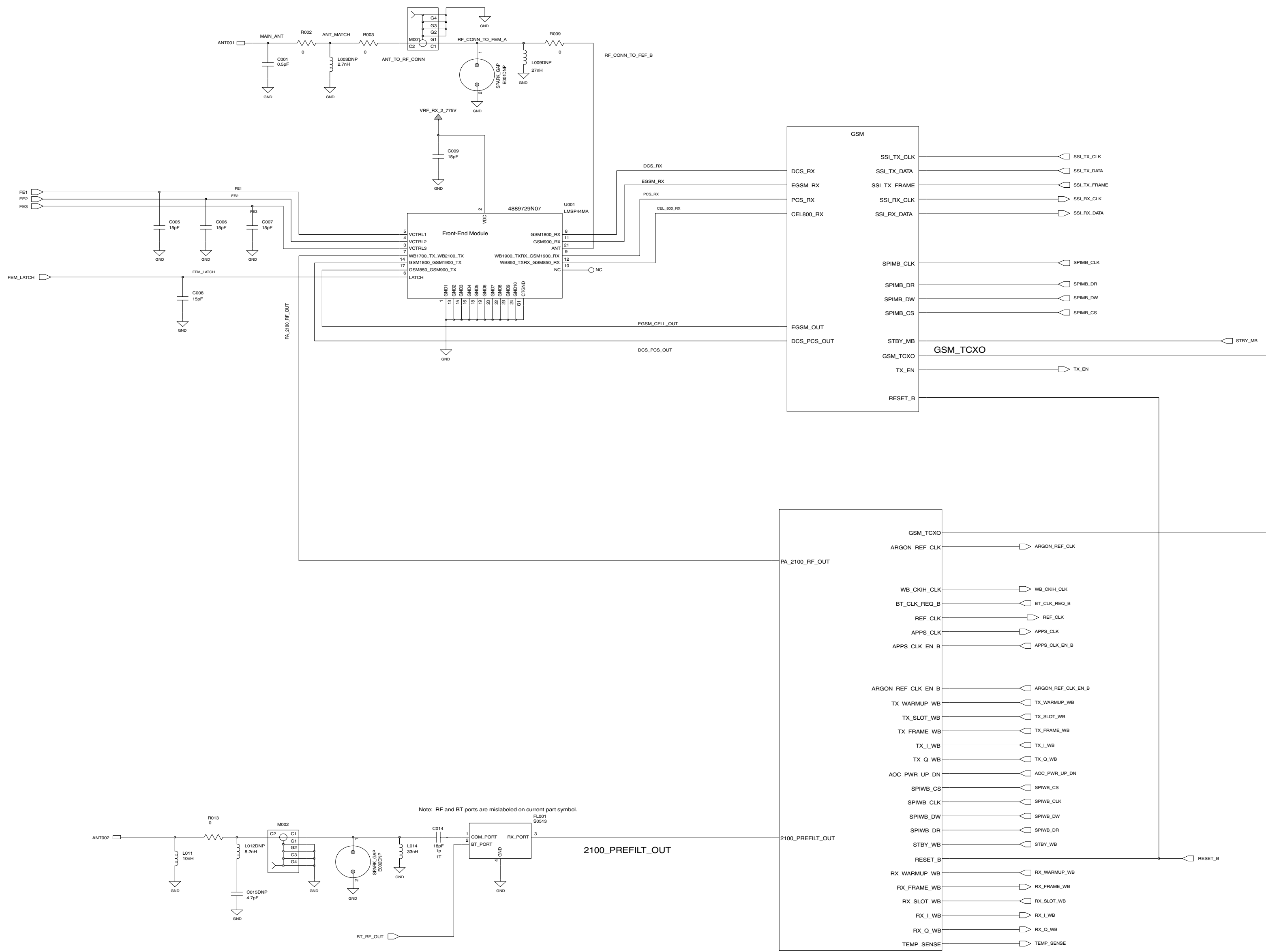

Revision 1.0: Initial Drawing



Service, Engineering & Optimization	2008.09.30
Level 3 Schematics	Rev. 1.0
V9 Europe with ORNAND Memory	8471274E01
	Page 13 of 16

V9 Europe with ORNAND_5471274E01

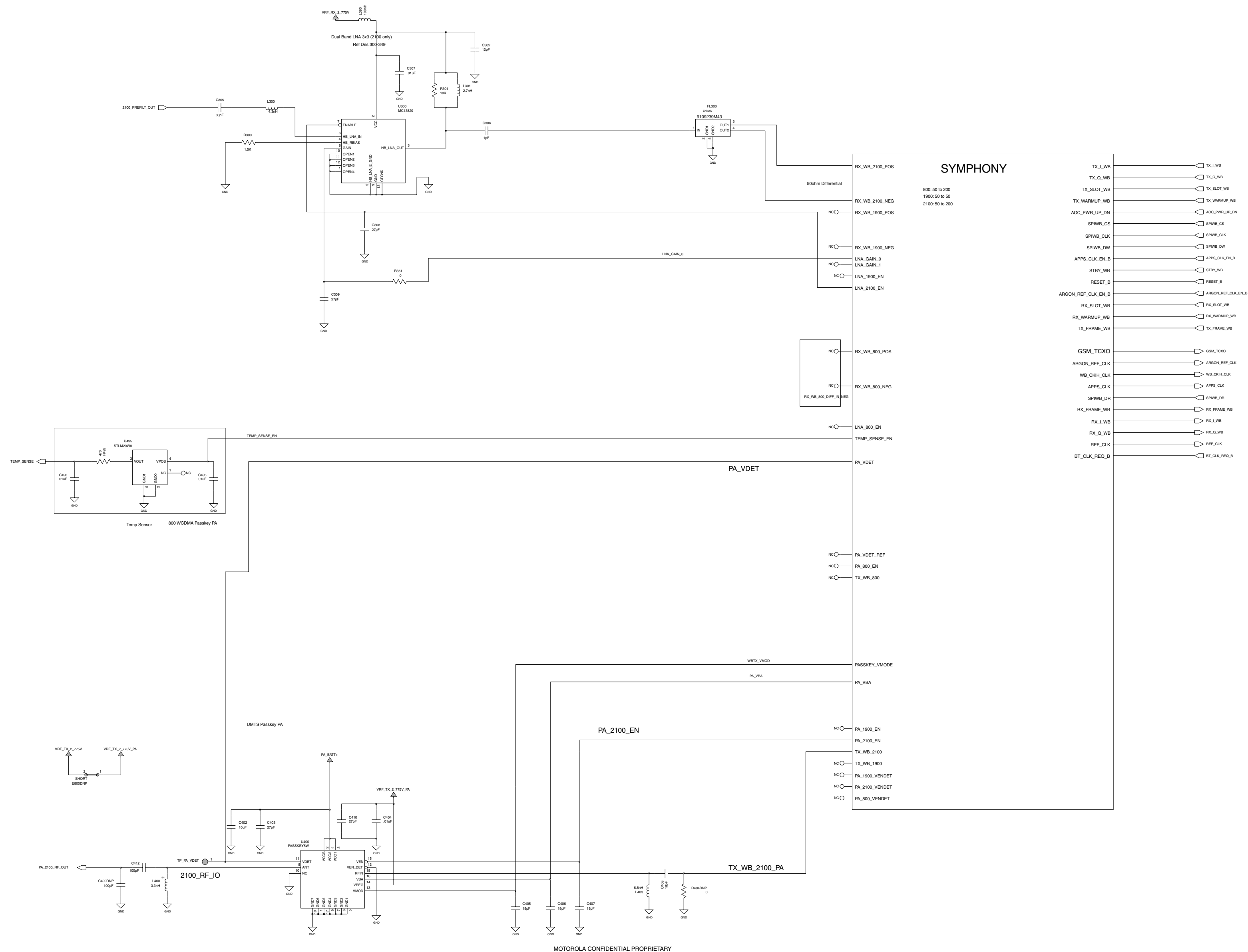

MOTOROLA CONFIDENTIAL PROPRIETARY

Revision 1.0: Initial Drawing



Service, Engineering & Optimization	2008.09.30
Level 3 Schematics	Rev. 1.0
V9 Europe with ORNAND Memory	8471274E01
	Page 15 of 16

