



MOTOROLA

Level 1 and 2 Service Manual

6809511A13-O

MOTORAZR² v8



GSM 850/900/1800/1900 MHz EDGE, GPRS

MOTOROLA and the Stylized M Logo are registered in the US Patent & Trademark Office.
All other product or service names are the property of their respective owners.

The Bluetooth trademarks are owned by their proprietor and used by Motorola, Inc. under license.
© Motorola, Inc. 2007.
All rights reserved.

Mobile Devices Business,
Sawgrass International Concourse
789 International Parkway
Room S2C
Sunrise, FL 33325-6220

Contents

Introduction	5
Product Identification	5
Product Names	5
Product Changes	5
Regulatory Agency Compliance	5
Computer Program Copyrights	6
About This Service Manual	6
Warranty Service Policy	7
Parts Replacement	7
Specifications	9
Product Overview	11
Features	11
General Operation	15
Controls, Indicators, and Input / Output (I/O) Connections	15
Battery Function	19
Operation	19
Tools and Test Equipment	21
Disassembly	22
Removing and Replacing the Battery Cover and Battery	22
Removing and Replacing the Subscriber Identity Module (SIM)	24
Removing and Replacing the Rear Housing	25
Removing and Replacing the Transceiver Board Assembly	34
Removing and Replacing the Antenna	37
Removing and Replacing the Keypad	39
Removing and Replacing the Flip Assembly	46
Subscriber Identity Module (SIM) and Identification	77
SIM Card	77
Personality Transfer	77
Identification	77
Troubleshooting	79
Manual Test Mode	79
Manual Test Mode Commands	79
Troubleshooting Chart	81
Programming: Software Upgrade and Flexing	83
Part Numbers	83
Exploded View Diagram	84
Exploded View Parts List	86
Accessories	89

Introduction

Motorola® Inc. maintains a worldwide organization that is dedicated to provide responsive, full-service customer support. Motorola products are serviced by an international network of company-operated product-care centers as well as authorized independent service firms.

Available on a contract basis, Motorola Inc. offers comprehensive maintenance and installation programs that allow customers to meet requirements for reliable, continuous communications.

To learn more about the wide range of Motorola service programs, contact your local Motorola products representative or the nearest Customer Service Manager.

Product Identification

Motorola products are identified by the model number on a label usually located under the battery. Use the entire model number when inquiring about the product. Numbers are also assigned to chassis and kits. Use these numbers when requesting information or ordering replacement parts.

Product Names

Product names are listed on the front cover. Product names are subject to change without notice. Some product names, as well as some frequency bands, are available only in certain markets.

Product Changes

When electrical, mechanical or production changes are incorporated into Motorola products, a revision letter is assigned to the chassis or kit affected, for example; -A, -B, or -C, and so on.

The chassis or kit number, complete with revision number, is imprinted during production. The revision letter is an integral part of the chassis or kit number and is also listed on schematic diagrams and printed-circuit board layouts.

Regulatory Agency Compliance

This device complies with Part 15 of the FCC Rules. Operation is subject to the following conditions:

- This device may not cause any harmful interference
- This device must accept interference received, including interference that may cause undesired operation

This class B device also complies with all requirements of the Canadian Interference-Causing Equipment Regulations (ICES-003).

Cet appareil numérique de la classe B respecte toutes les exigences du Règlement sur le matériel brouilleur du Canada.

Computer Program Copyrights

The Motorola products described in this manual may include Motorola computer programs stored in semiconductor memories or other media that are copyrighted with all rights reserved worldwide to Motorola. Laws in the United States and other countries preserve for Motorola, Inc. certain exclusive rights to the copyrighted computer programs, including the exclusive right to copy, reproduce, modify, decompile, disassemble, and reverse-engineer the Motorola computer programs in any manner or form without Motorola's prior written consent. Furthermore, the purchase of Motorola products shall not be deemed to grant either directly or by implication, estoppel, or otherwise, any license or rights under the copyrights, patents, or patent applications of Motorola, except for a nonexclusive license to use the Motorola product and the Motorola computer programs with the Motorola product.

About This Service Manual

Use of this manual assures proper installation, operation, and maintenance of Motorola products and equipment. It contains all service information required for the equipment described and is current as of the printing date. Refer questions about this manual to the nearest Customer Service Manager.

Audience

This manual aids service personnel in testing and repairing V8 telephones. Service personnel should be familiar with electronic assembly, testing, and troubleshooting methods, and with the operation and use of associated test equipment.

Scope

This manual provides basic information relating to V8 telephones, and also provides procedures and processes for repairing the phones at Level 1 and 2 service centers including:

- Unit swap out
- Repairing of mechanical faults
- Basic modular troubleshooting
- Testing and verification of unit functionality
- Initiate warranty claims and send faulty modules to Level 3 or 4 repair centers

Conventions

The following special characters and typefaces, are used in this manual to emphasize certain types of information.



Note: Emphasizes additional information pertinent to the subject matter.



Caution: Emphasizes information about actions which may result in equipment damage.



Warning: Emphasizes information about actions which may result in personal injury.

Warranty Service Policy

The product is sold with the standard 12-month warranty terms and conditions. Accidental damage, misuse, and extended warranties offered by retailers are not supported under warranty. Non-warranty repairs are available at agreed fixed repair prices.

Out-of-Box Failure Policy

The standard out-of-box failure criteria applies. Return customer units that fail very early on after the date of sale to Manufacturing for root cause analysis, to guard against epidemic criteria. Manufacturing to bear the costs of early life failure.

Product Support

Customer's original units will be repaired but not refurbished as standard. Appointed Motorola Service Hubs will perform warranty and non-warranty field service for level 2 (assemblies) and level 3 (limited PCB component). Motorola High Tech Centers will perform level-4 (full component) repairs.

Customer Support

Customer support is available through dedicated Call Centers and in-country help desks. Product Service training is available through the local Motorola Support Center.

Parts Replacement

When ordering replacement parts or equipment, include the Motorola part number and description used in the service manual.

When the Motorola part number of a component is not known, use the product model number or other related major assembly along with a description of the related major assembly and of the component in question.

Replacement Parts Service Division (RPSD)

Order replacement parts, test equipment, and manuals from RPSD.

U.S.A.

Phone: 800-422-4210

FAX: 800-622-6210

Website: <http://businessonline.motorola.com>

Outside U.S.A.

Phone: 847-538-8023

FAX: 847-576-3023

EMEA

Phone: +49 461 803 1404

Website: <http://emeaonline.motorola.com>

Asia

Phone: +65 648 62995

Website: <http://asiaonline.motorola.com>

Specifications

General Function	Specification
Frequency Range GSM 850	824-848 MHz Tx 869-893 MHz Rx
Frequency Range GSM 900	880-915 MHz Tx (with EGSM) 925-960 MHz Rx
Frequency Range DCS 1800	1710-1785 MHz Tx 1805-1880 MHz Rx
Frequency Range PCS 1900	1850-1910 MHz Tx 1930-1990 MHz Rx
Channel Spacing	200 kHz
Channels	174 EGSM, 374 DCS, 374 PCS, 124 GSM 850 carriers with 8 channels per carrier
Modulation	GMSK at BT = 0.3
Transmitter Phase Accuracy	5 Degrees RMS, 20 Degrees peak
Duplex Spacing	45 MHz
Frequency Stability	± 0.10 ppm of the downlink frequency (Rx)
Operating Voltage	+3.2V dc to +5.5V dc (battery) +4.8V dc to +6.5V dc (external connector)
Transmit Current Drain	101-260 mA average talk current drain
Stand-by Current drain	5 mA (DRX2), 2 mA (DXR9) typical
Temperature Range	-10° C to +55° C (+15° F to +130° F)
Dimensions, with 770 mAh Li Ion battery	53mm x 103mm x 12mm
Size (Volume)	60 cc
Weight	117 grams with battery
Battery Life, with standard 770 mAh Li-Ion Battery	Talk Time up to 450 minutes Standby time up to 280 hours All talk and standby times are approximate and depend on network configuration, signal strength, and features selected. Standby times are quoted as a range from DRX=2 to DRX=9. Talk times are quoted as a range from DTX off to DTX on.
Battery Charge Time	4 hours to 90% of 770 mAh capacity
Alert volume	Max 95 dB @5cm, 0.5 Watts input

Transmitter Function	Specification
RF Power Output	32 dBm nominal GSM 850/900, 29 dBm nominal GSM 1800/1900
Output Impedance	50 ohms nominal
Spurious Emissions	-36 dBm from 0.1 to 1 GHz, -30 dBm from 1 to 4 GHz

Receiver Function	Specification
Receive Sensitivity	Better than -103 dBm
RX Bit Error Rate (100k bits) Type II	< 2%

Speech Coding Function	Specification
Speech Coding Type	Regular pulse excitation/linear predictive coding with long term prediction (RPE LPC with LTP)
Bit Rate	13.0 kbps

Speech Coding Function	Specification
Frame Duration	20 ms
Block Length	260 bits
Classes	Class 1 bits = 182 bits; Class 2 bits = 78 bits
Bit Rate with FEC Encoding	22.8 kbps

Product Overview

MOTORAZR 2 V8 telephones represent the thinnest, compact and lightweight global system for mobile communications (GSM) general packet radio service (GPRS) wireless application protocol (WAP)-enabled mobile phones. The V8 phones incorporate an improved user interface for easier operation, allows multimedia message service (MMS) messaging, and includes personal information manager (PIM) functionality.

The V8 is a quad-band phone that allows roaming within the GSM 900 MHz, GSM 850 MHz, 1800 MHz digital cellular system (DCS), and 1900 MHz PCS bands.

V8 telephones support GPRS and Enhanced Data rates for GSM Evolution (EDGE) in addition to traditional circuit switched transport technologies.

The V8 phone consists of a main housing assembly and a flip assembly. The main circuit board, battery, and accessory connector are located in the main housing assembly. The camera on the V8 phone is located in the hinged flip assembly. The standard 770 mAh Lithium Ion (Li Ion) battery fits behind a removable back cover and provides up to 500 minutes of talk time with up to 280 hours of standby time¹.

The flip assembly contains the entire hinge mechanism. It is attached to the main housing by four screws. The display module consists of 240 x 320 pixel, Active Matrix Liquid Crystal Display (AMLCD) with white pixels on a black background. The CLI screen is a 2.0" transmissive sub display, and the primary screen is a 2.2" transmissive main display.

The camera module is a 2.0 mega pixel VGA CMOS camera.

The main housing assembly includes a battery cover, chassis, main circuit board, keypad plastic front housing, and internal antenna.

The main circuit board contains the Receiver, Transmitter, Synthesizer and Control Logic Circuitry and phone electronics.

The telephones are made of polycarbonate plastic. The display and speaker, as well as the 23-key keypad, transceiver printed-circuit board (PCB), microphone, charger and headphone connectors, and power button are contained within the flip form-factor housing.

The phone accepts both 3V and 1.8V mini subscriber identity module (SIM) cards which fit into the SIM holder next to the battery. The antenna is mounted internally. Inexpensive direct connection to a computer or handheld device provided by USB or Bluetooth® for data and fax calls, and for synchronizing phonebook entries with Mobile Phone Tools software, can be accomplished by using the optional data cable and soft modem.

Features

V8 telephones use advanced, self-contained, sealed, custom integrated circuits to perform the complex functions required for GSM communication. Aside from the space and weight advantage, microcircuits enhance basic reliability, simplify maintenance, and provide a wide variety of operational functions.

Features available in this family of telephones include:

1. All talk and standby times are approximate and depend on network configuration, signal strength, and features selected.

- 240 x 320 262K TFT Main Display (2.2"), external display (2.0")
- 2.0 megapixel VGA CMOS Camera (1600 x 1200 pixels)
- Polyphonic Speaker
- Messaging: SMS, MMS, WV
- Audio CODECs: Windows WMA plus Janus DRM, MP3, AAC, AAC+, eAAC+, WAV
- Video: Capture/Playback, h.263, MPEG4 3GPP
- Connectivity: Bluetooth® Class 2, USB-2.0 HS, Mobile Phone Tools, Over the Air Sync (OTA)
- Up to 512MB or 2GB on board memory

Speaker Dependent Voice Activation and Voice Note Recording

Voice tags can be used for voice dialing up to 20 phone numbers in the phone book and for creating up to 5 voice shortcuts for menu items. The phone must be “trained” by the voice tag being read into the phone’s memory twice before it is recognized.

You can add voice tags to the phone’s memory using the usual name addition methods (i.e., via the phone book menu structure or with the shortcut editor).



You cannot place or receive calls while adding voice tags to the phone’s memory.



Because the GSM standard does not provide the option to store voice tags onto the SIM card, voice tags are added to the phone’s memory.

V8 telephones also include a voice recorder that allows up to 2 minutes of personal messages to be recorded. This feature has a complete set of record, playback, and management tools that make it easy to store and maintain a list of personal memos.

Wireless Access Protocol (WAP) 1.1 Compliancy

In the WAP environment, access to the Internet is initiated in wireless markup language (WML), which is derived from hypertext markup language (HTML). The request is passed to a WAP gateway that retrieves the information from the server in standard HTML (subsequently filtered to WML) or directly in WML if available. The information is then passed to the mobile subscriber via the mobile network.

The V8 microbrowser can be configured for baud, idle timeout, line type, phone number, and connection type.



Bitmap image data will download as text. If the image is larger than the screen, only part of the image will display.



When the user receives a call while in browser mode, the browser will pause and allow the user to resume after completing the call.

SIM Application Toolkit™ - Class 2

SIM Application Toolkit is a value-added service delivery mechanism that allows GSM operators to customize the services they offer their customers, from the occasional user who requests sports news and traffic alerts, to a high call time business user who receives stock alerts and checks flight times. Operators can now create their own value-added services menu quickly and easily in the phone. The customized menu will appear as the first menu and may be updated over-the-air with new services when customers request them.

Simplified Text Entry

There are three different ways to enter text using the phone keypad:

- iTAP™ predictive text entry. Press a key to generate a character and a dynamic dictionary uses this to build and display a set of word or name options. The iTAP™ feature may not be available on the phone in all languages.
- Tap. Press a key to generate a character.
- Numeric. The keypad produces numeric characters only. For some text areas this is the only method available; for example, phone numbers.

Caller Line Identification

Upon receipt of a call, the calling party's phone number is compared to the phone book. If the number matches a phone book entry, that name will be displayed. If there is no phone book entry, the incoming phone number will be displayed. In the event that no caller identification information is available, the Incoming Call message is displayed.



User must subscribe to a caller line identification service through their service provider.

Other Features

Detailed descriptions of these and other V8 features can be found in the user's guide.

General Operation

Controls, Indicators, and Input / Output (I/O) Connections

The V8 controls are located on the sides of the flip and on the keypad. See Figure 1.

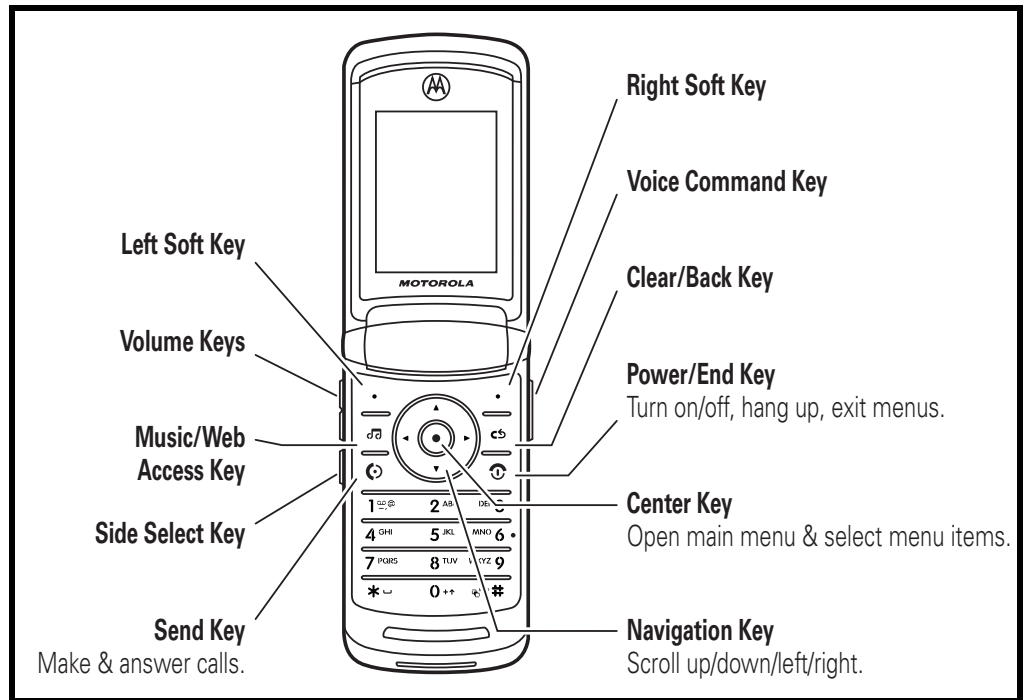

0700620

Figure 1. Controls, indicators, and I/O

The V8 phone has a large external display on the outside of the flip. The phone's charging indicator, camera lens, and Bluetooth indicator are also located on the flip along with other external controls. The phone has a micro USB port, located on the left side of the phone.

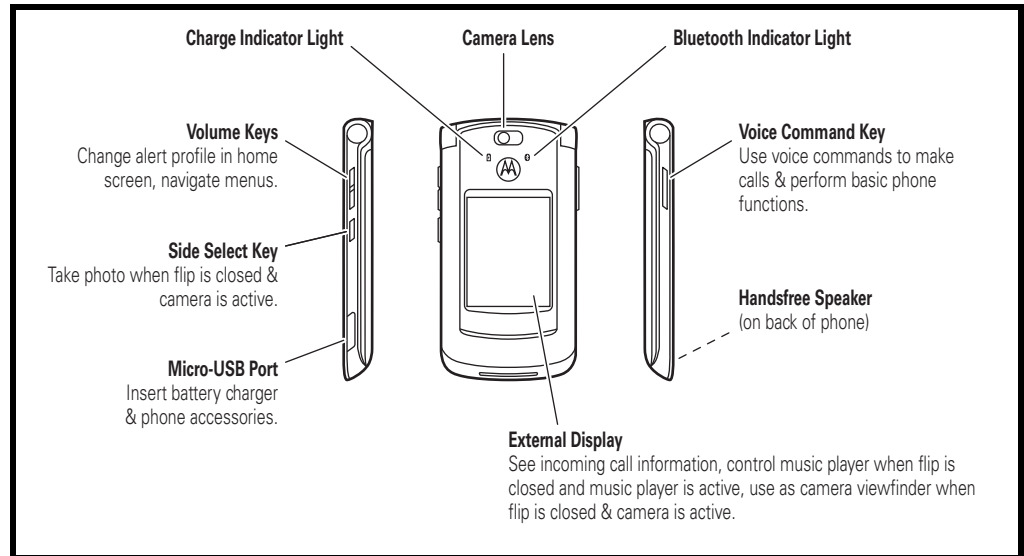

0700630

Figure 2. Additional Controls, indicators, and I/O

Color Display

The V8 wireless phones feature a 240 x 320 262K TFT Main Display (2.2"), external display (2.0").

The center key opens the initial menu structure, or allows access to a submenu.

“Soft keys” refer to non-labeled keys that correspond to text options displayed on the screen. The left and right soft keys perform the function shown in the corners of the display. The right key will usually select an option whereas the left key will usually exit a function or return to a previous screen (see Figure 3).

Indicators, in the form of icons, display on the LCD. Figure 3 shows some of the icons that display on the LCD.

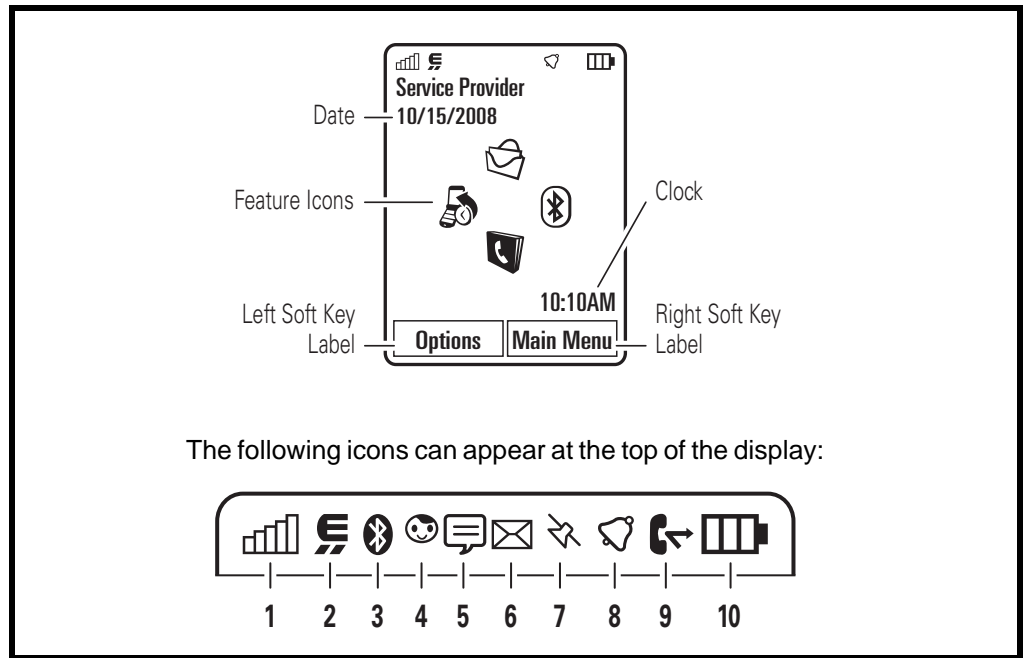

070048o, 070049o

Figure 3. Icon Indicators



Whether a phone displays all indicators depends on the programming and services to which the user subscribes.

1 Signal Strength Indicator – Vertical bars show the strength of the wireless network connection. You can't make or receive calls when Ψ or $\Psi\emptyset$ shows. The roam indicator $\hat{\Psi}$ shows when your phone is seeking or using a network outside your home network.

2 EDGE/GPRS Indicator – Shows when your phone is using a high-speed *Enhanced Data for GSM Evolution (EDGE)* or *General Packet Radio Service (GPRS)* network connection. Indicators can include:



- | | |
|--|--|
| \mathcal{E} = EDGE connection | \mathcal{G} = GPRS connection |
| $\mathcal{E}\rightarrow$ = EDGE data transfer | $\mathcal{G}\rightarrow$ = GPRS data transfer |
| $\mathcal{E}\rightarrow\rightarrow$ = EDGE secure data transfer | $\mathcal{G}\rightarrow\rightarrow$ = GPRS secure data transfer |
| $\mathcal{E}\rightarrow\rightarrow\rightarrow$ = EDGE unsecure data transfer | $\mathcal{G}\rightarrow\rightarrow\rightarrow$ = GPRS unsecure data transfer |

3 Bluetooth™ Indicator – Shows Bluetooth power, connection, and discoverable status as follows:

solid blue = Bluetooth powered on
 solid green = Bluetooth connected
 flashing blue = Bluetooth discoverable mode

4 Messaging Presence Indicator – Shows your instant messaging (IM) status. Indicators can include:



= online = offline
 = busy = discrete
 = invisible to IM

5 IM Indicator – Shows when you receive a new IM message.



6 Message Indicator – Shows when you receive a new message. Indicators can include:



= text or voice message = email message

7 Location Indicator – Shows your phone's location information status. Indicators can include:



= location on = location off
 = acquiring location = location fixed
 = location unknown

8 Profile Indicator – Shows the alert profile setting.

= ring only = silent
 = vibrate only = vibrate then ring

9 Active Line Indicator – Shows to indicate an active call, or to indicate when call forwarding is on. Indicators for dual-line-enabled SIM cards can include:



= line 1 active = line 2 active
 = line 1 call forward on = line 2 call forward on

10 Battery Level Indicator – Vertical bars show the battery charge level.

Battery Function

Battery Gauge

The telephone displays a battery level indicator icon in the idle screen to indicate the battery charge level. The gauge shows four levels: 100%, 66%, 33%, and Low Battery.

Battery Removal

Removing the battery causes the device to immediately shut down and any pending work (for example, partially entered phone book entries or outgoing messages) is lost.



To ensure proper memory retention, turn OFF the phone before removing the battery.



If the battery is removed while receiving a message, the message will be lost.

Operation

For detailed operating instructions, refer to the appropriate User's Guide.

Tools and Test Equipment

The following table lists tools and test equipment recommended for disassembly and reassembly of V8 telephones. Use either the listed items or equivalents.

Table 1. General Test Equipment and Tools

Motorola Part Number ¹	Description	Application
RSX4043-A	Torque Driver	Used to remove and replace screws
—	Torque Driver Bit T-5 Plus, Apex 440-6IP Torx Plus or equivalent	Used with torque driver
See Table 7	Rapid Charger	Used to charge battery and to power device
0180386A82	Antistatic Mat Kit (includes 66-80387A95 antistatic mat, 66-80334B36 ground cord, and 42-80385A59 wrist band)	Provides protection from damage to device caused by electrostatic discharge (ESD)
6680388B67	Disassembly tool, plastic with flat and pointed ends (manual opening tool)	Used during assembly/disassembly of device
6680388B01	Tweezers, plastic	Used during assembly/disassembly
—	Digital Multimeter, HP34401A ²	Used to measure battery voltage
8102430Z04	GSM / DCS Test SIM	Used to enable manual test mode
19501980	Generic Press	
0-00-00-40869	P-Flex and CLI lens Press Fixture	
0-00-00-40870	Main Lens Press Fixture	
0-00-00-40871	Hand Held Speaker Press Fixture	
0-00-00-40872	Hinge Shaft Key Press Fixture	
0-00-00-40873	K-Flex / Rear Housing gasket / Earpiece gasket alignment fixture kit	
0-00-00-40877	Keypad Tab Bend Fixture	

1. To order in North America, contact Motorola Aftermarket and Accessories Division (AAD) at (800) 422-4210 or FAX (800) 622-6210; Internationally, AAD can be reached by calling (847) 538-8023 or faxing (847) 576-3023.

2. Not available from Motorola. To order, contact Hewlett Packard at (800) 452-4844.

Disassembly

The procedures in this section provide instructions for the disassembly of V8 telephones. Tools and equipment used for the phone are listed in Table 1, preceding.



Many of the integrated devices used in this equipment are vulnerable to damage from electrostatic discharge (ESD). Ensure adequate static protection is in place when handling, shipping, and servicing the internal components of this equipment.



Avoid stressing the plastic in any way to avoid damage to either the plastic or internal components.

Removing and Replacing the Battery Cover and Battery



All batteries can cause property damage and/or bodily injury, such as burns if a conductive material, such as jewelry, keys, or beaded chains touch exposed terminals. The conductive material may complete an electrical circuit (short circuit) and become quite hot. Exercise care in handling any charged battery, particularly when placing it inside a pocket, purse, or other container with metal objects.

1. Ensure the phone is turned off.
2. Push the battery cover up (toward the top of the phone) to release (see Figure 1).

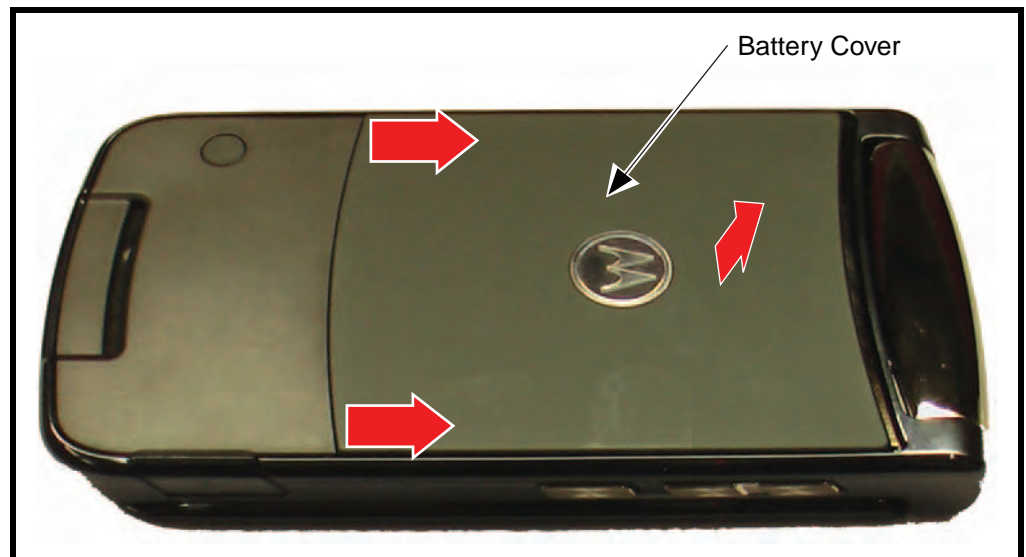

v470113

Figure 1. Removing the Battery Cover

3. Lift up and remove the battery cover.

4. Pull the tab on the label near the hinge, then remove the battery from the phone. See Figure 2.

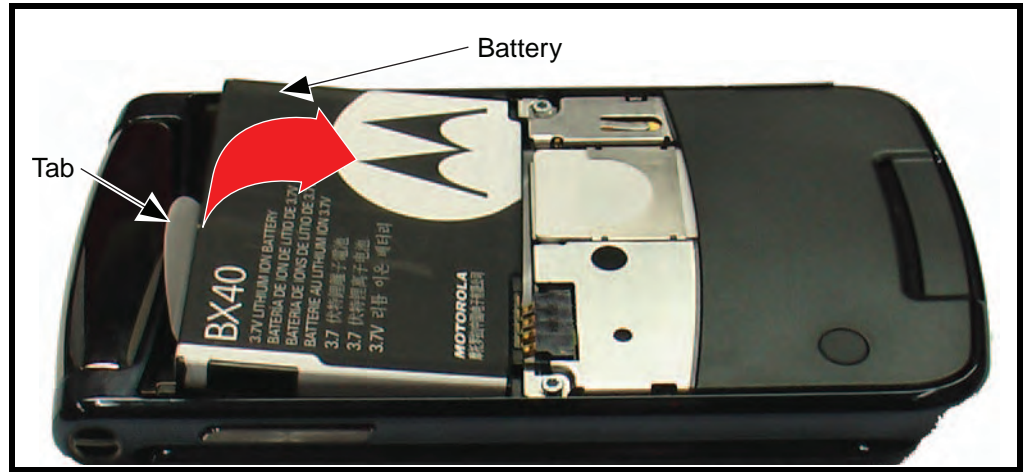

Figure 2. Removing the Battery



There is a danger of explosion if the Lithium Ion battery is replaced incorrectly. Replace only with the same type of battery or equivalent as recommended by the battery manufacturer. Dispose of used batteries according to the manufacturer's instructions.

5. To replace, align the battery with the battery compartment so the contacts on the battery match the battery contacts in the phone.
6. Insert the battery, contacts side first, into the battery compartment and push down followed by the opposite edge of the battery.
7. Insert the bottom edge of the of the battery cover into the rear housing, then push the top edge of the cover down and snap it into place.

Removing and Replacing the Subscriber Identity Module (SIM)

1. Remove the battery cover and battery as described in the procedures.
2. Slide the SIM card out of the SIM holder, as shown in Figure 3.

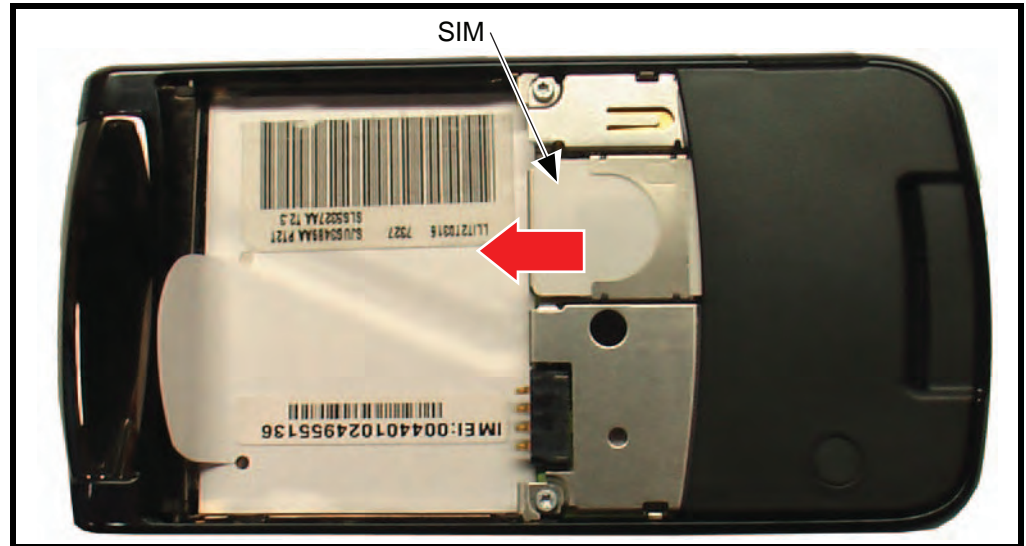

v470114

Figure 3. Removing the SIM

3. Carefully lift the SIM from the phone.
4. To replace, insert the SIM into the holder, ensuring the notched corner of the SIM is inserted first.
5. Replace the battery and battery cover as described in the procedures.

Removing and Replacing the Rear Housing



This product contains static-sensitive devices. Use anti-static handling procedures to prevent electrostatic discharge (ESD) and component damage.

1. Remove the battery cover, battery, and SIM as described in the procedures.



In addition to 2 screws, the rear housing assembly is fastened with plastic latches. These are fragile and should be released with care.

2. Using a Torx driver with a T-5 bit, remove the screws at each side of the phone. Retain the screws for reassembly. See Figure 4.

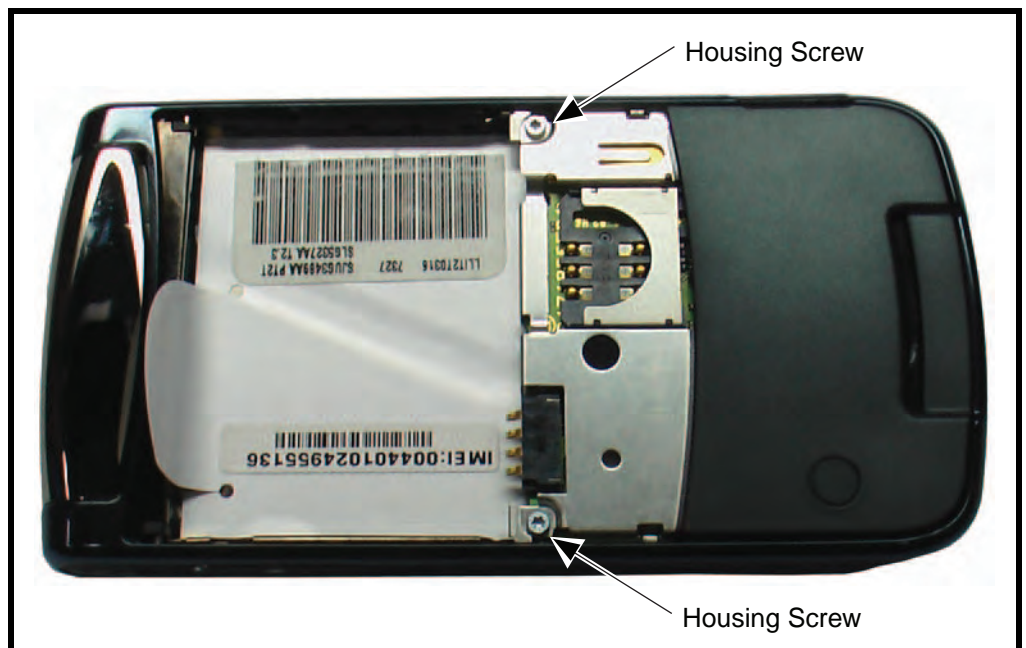

v470115

Figure 4. Removing the Rear Housing Screws

3. Turn the phone over so the keypad is facing upward.
4. Use the disassembly tool to remove the bumper pad below the keypad.

5. Use the T-5 driver to remove the two housing screws under the bumper pad (see Figures 5 and 6).



V462594

Figure 5. Removing the Bumper

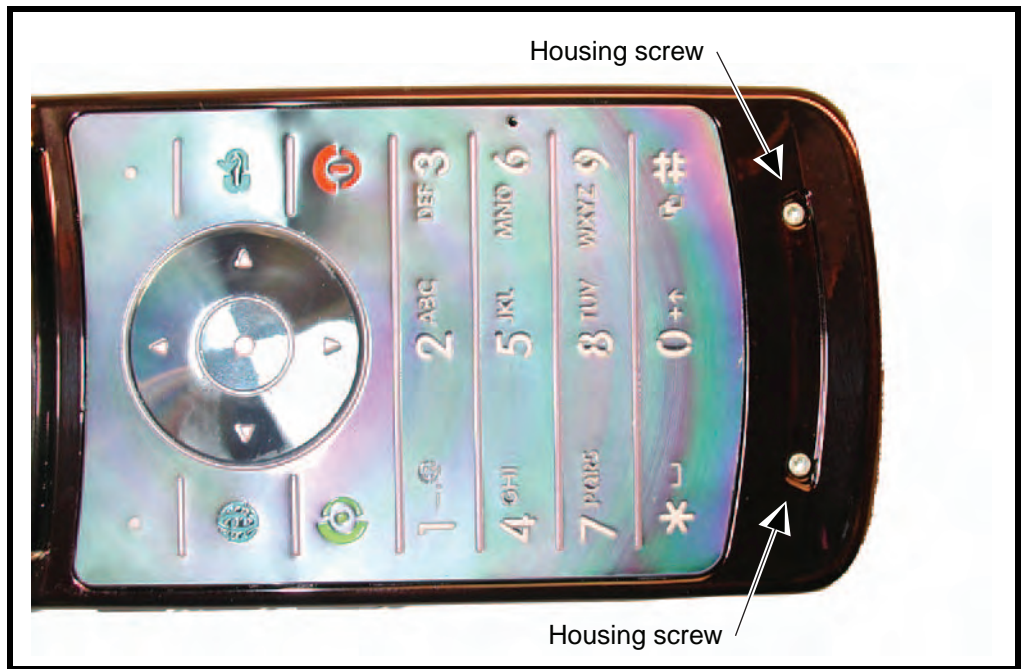

V458596

Figure 6. Removing the Rear Housing Screws

6. Release the first housing latch by inserting the flat edge of the plastic disassembly tool near the USB connector on the rear housing.

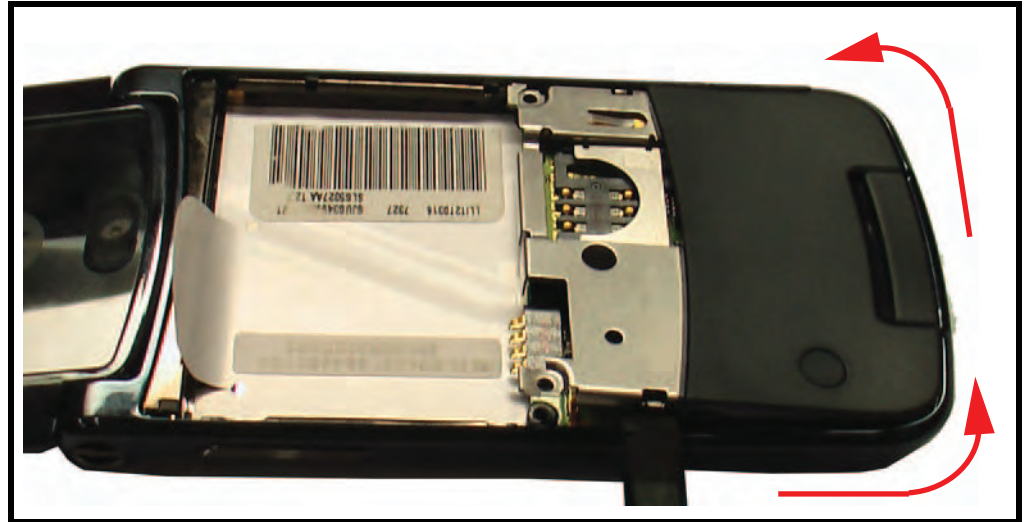

v470116

Figure 7. Removing the Rear Housing Latches

7. Slide the tool between the rear housing and front housing along the perimeter to release remaining housing snaps. Do not damage or mar the finish on the housings.
8. Lift the rear housing assembly away from the phone.
9. To replace, carefully align the flex connector to its socket on the rear housing assembly, then gently press down on the flex connector until it is properly seated in its socket.
10. Rotate the rear housing assembly so it sits over the phone.

11. Align the housing latches with the corresponding openings on the front housing. Gently press the housings together until the catches snap into place.

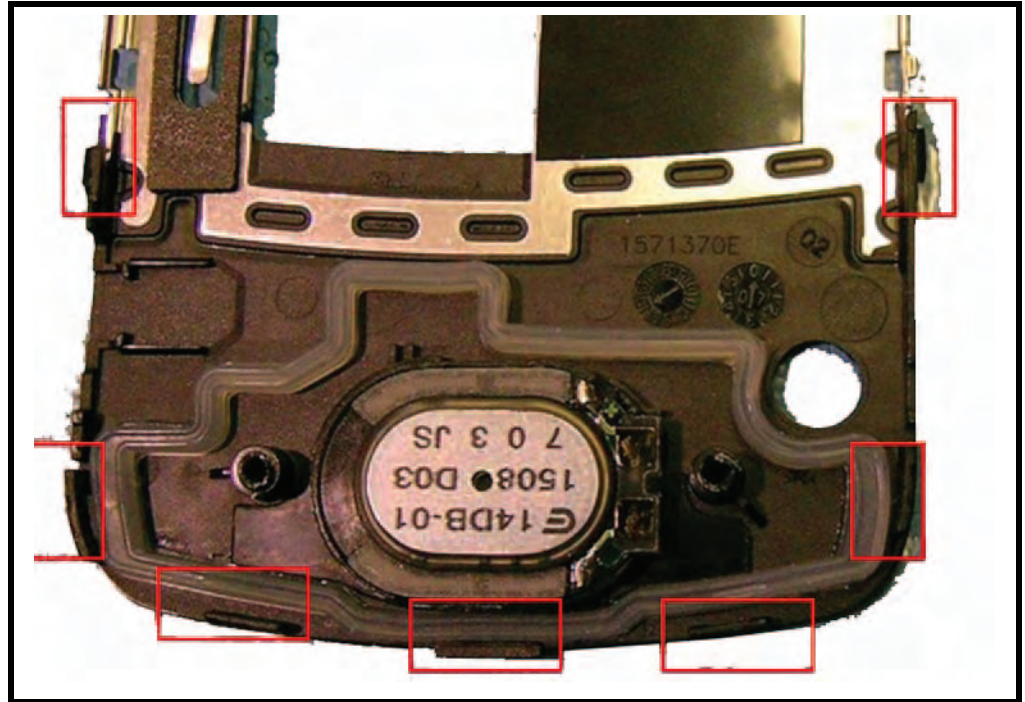

v462224

Figure 8. Rear Housing Latches

12. Replace the 2 housing screws and tighten to a final torque setting of 1.0 inch pounds. Do not over tighten.
13. Replace the 2 housing screws below the keypad.
14. Replace the bumper pad.
15. Replace the USB grommet.
16. Replace the memory card, battery, and battery cover as described in the procedures.

Replacing the Rear Housing Assembly

Piece part procedure for use by high volume repair centers only

1. Attach the speaker screen/grommet adhesive. See Figure 9.

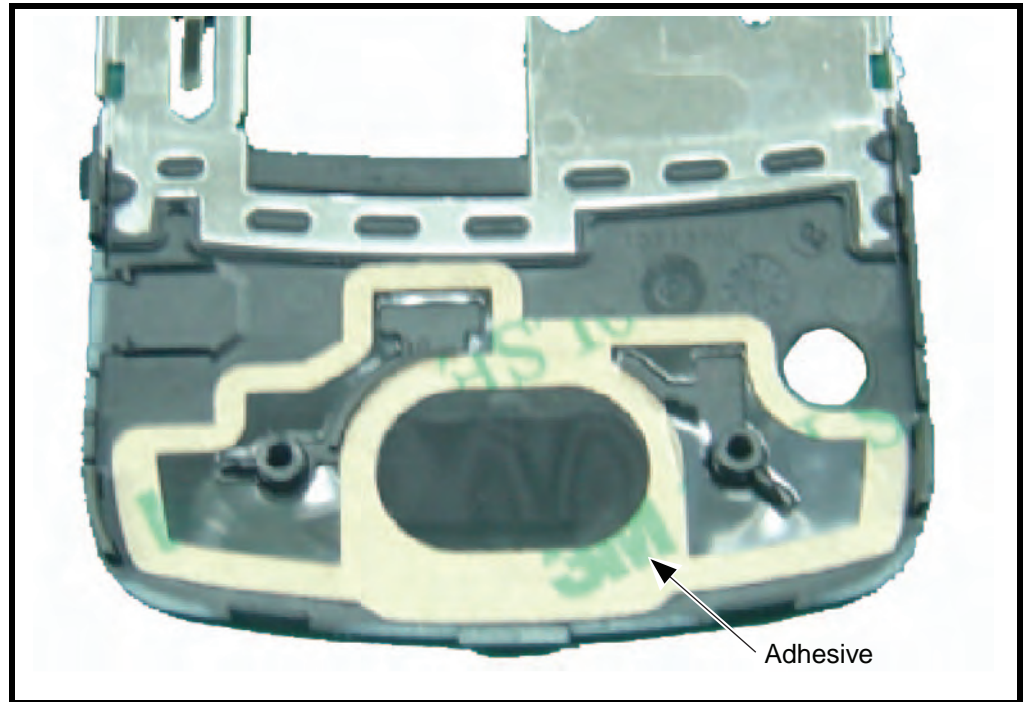
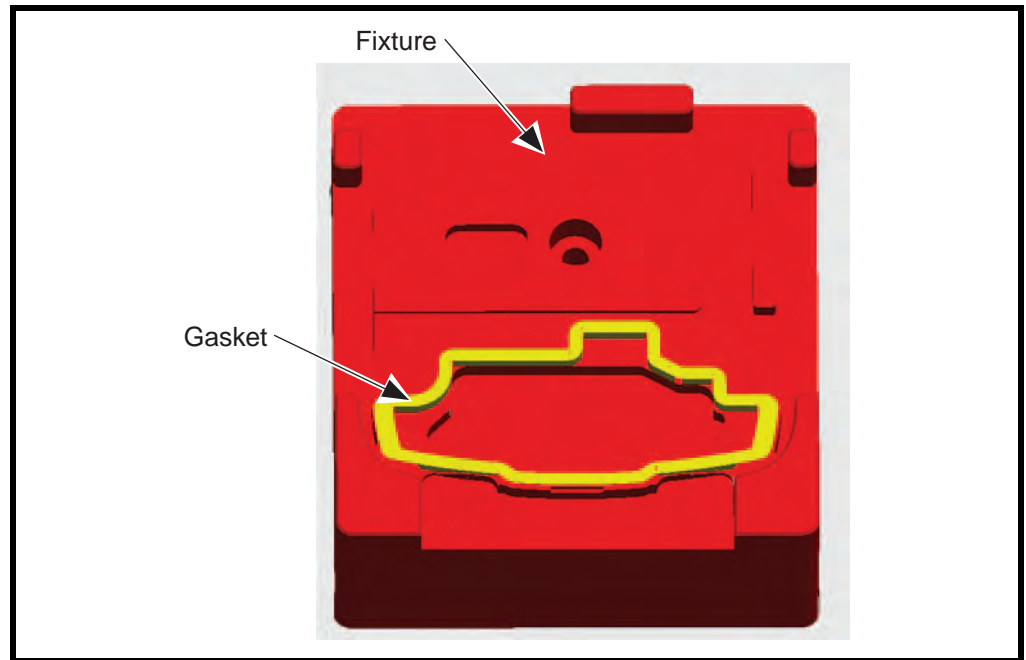

Figure 9. Rear Housing Assembly Adhesive

v462287

2. Expose the adhesive surface.

3. Place gasket into fixture.



v469260

Figure 10. Rear Housing Assembly Fixture

4. Place housing into the fixture and press by hand.

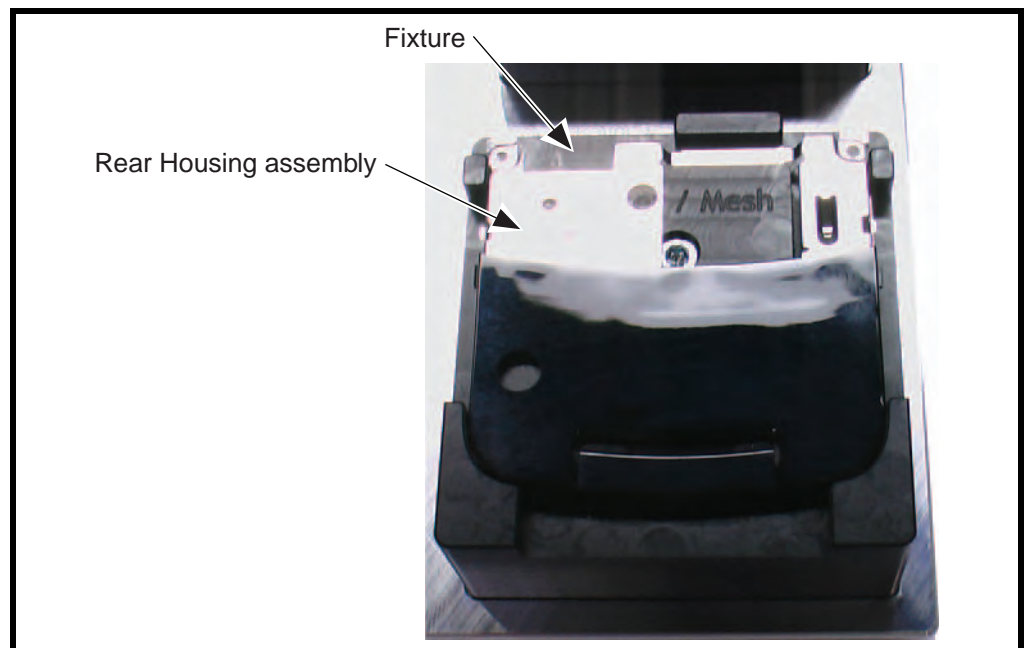

v473802

Figure 11. Attaching the Rear Housing Assembly

5. Place the speaker into the rear housing and press with service fixture.

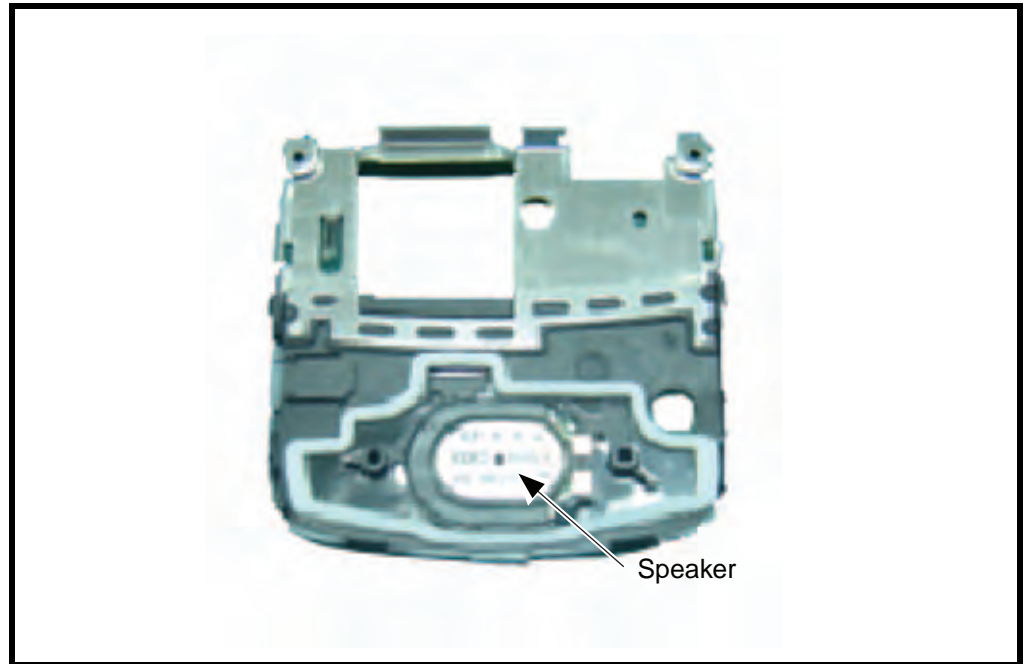

v462291

Figure 12. Rear Housing Assembly

6. Place the 70-pin pad into the rear housing.



v462292

Figure 13. Rear Housing Assembly

7. Place insulator tape.

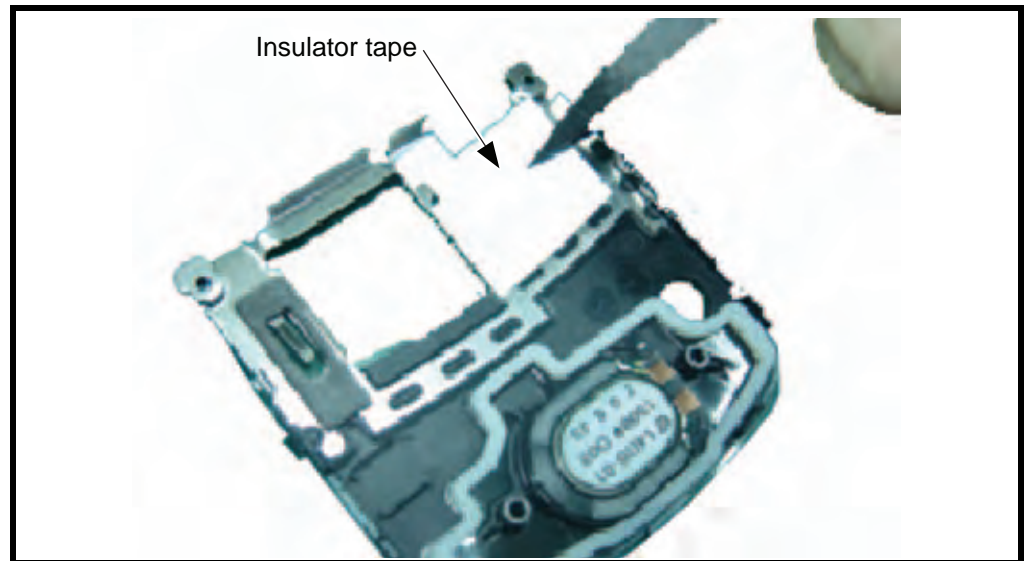

v462293

Figure 14. Installing the Insulator Tape in the Rear Housing

8. Install a VBuck pad.



v470131

Figure 15. Installing Vbuck Pad in the Rear Housing

9. Reinstall the rear housing assembly onto the phone. Continue the procedure beginning at step 12 on page 28.

Removing and Replacing the Transceiver Board Assembly



This product contains static-sensitive devices. Use anti-static handling procedures to prevent electrostatic discharge (ESD) and component damage.

1. Remove the battery cover, battery, SIM, and rear housing as described in the procedures.
2. Use the disassembly tool to unseat the flex connector from it's socket on the transceiver board (see Figure 16).

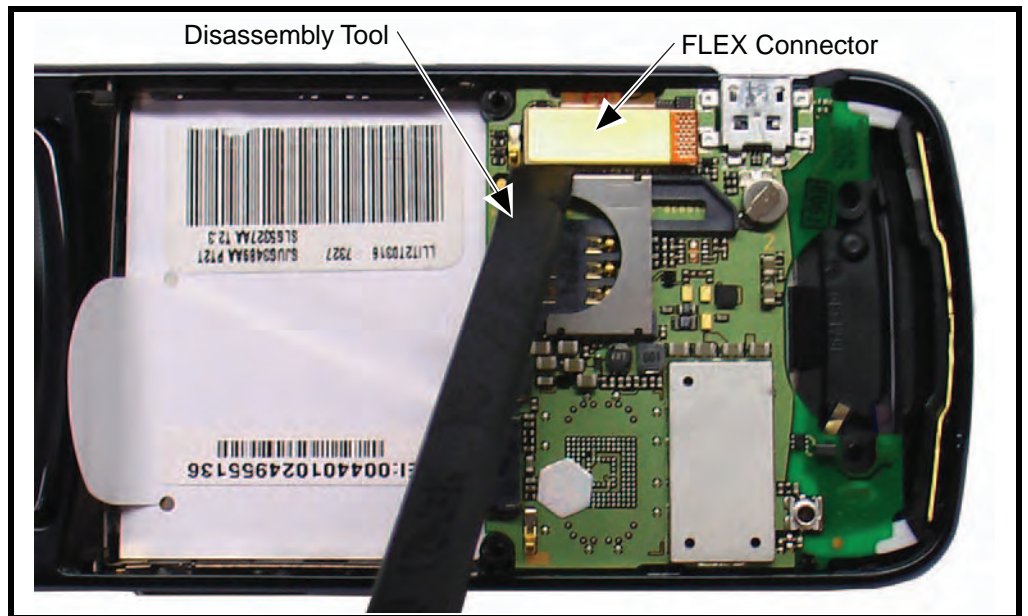

V470133

Figure 16. Unseating the Flex Connector



The flexible printed cable (FPC) (flex) is easily damaged. Exercise extreme care when handling.

3. Lift the transceiver board assembly out of the front housing with the plastic tweezers. See Figure 17.

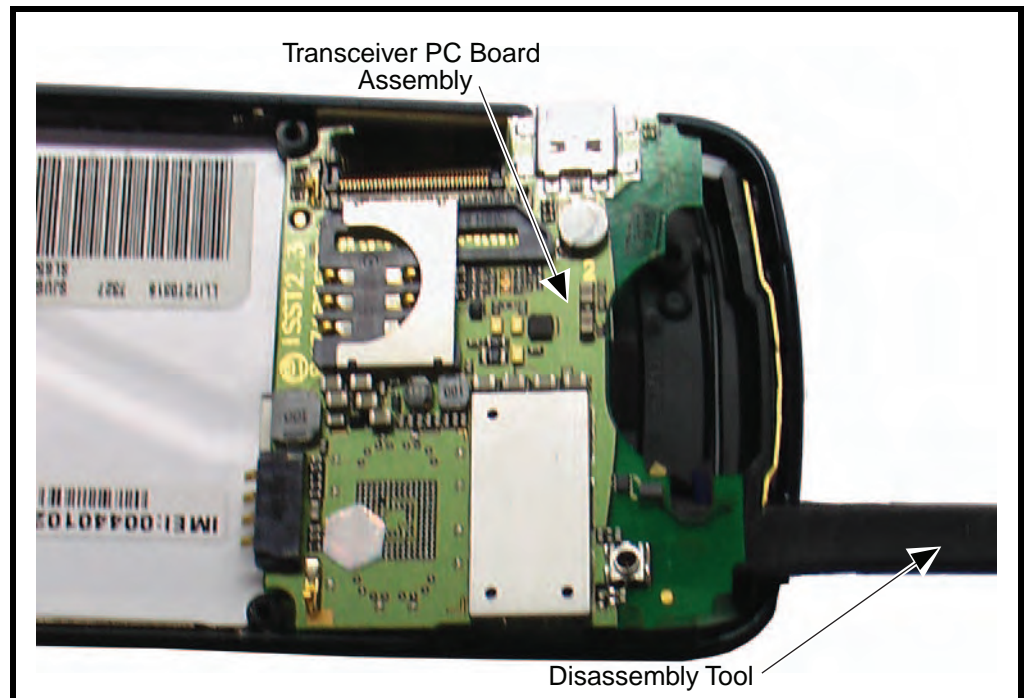

v470134

Figure 17. Removing the Transceiver PC board Assembly

4. To replace, install the grounding clip onto the transceiver board assembly. Use the latches (shown in the red areas) to secure the clip to the transceiver board.

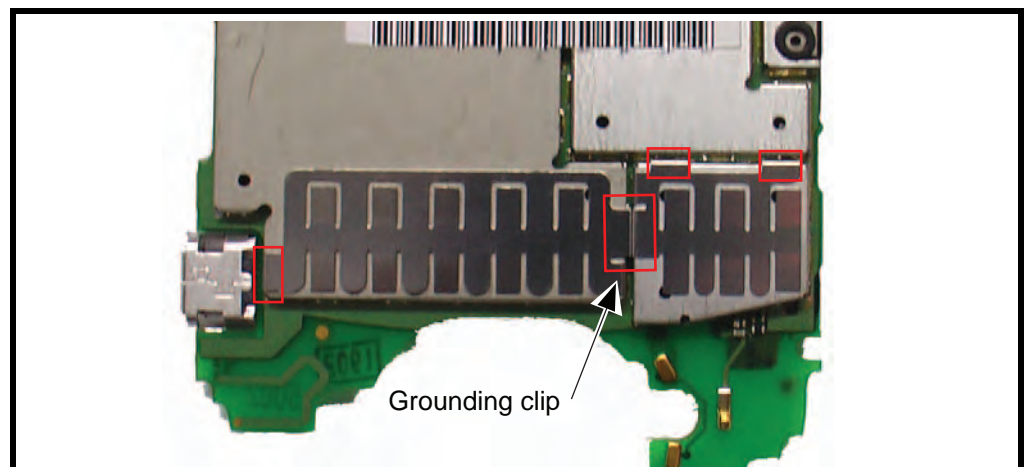

v463226

Figure 18. Removing the Transceiver PC board Assembly

5. Place the transceiver PCB into the housing.

6. Place the USB grommet.

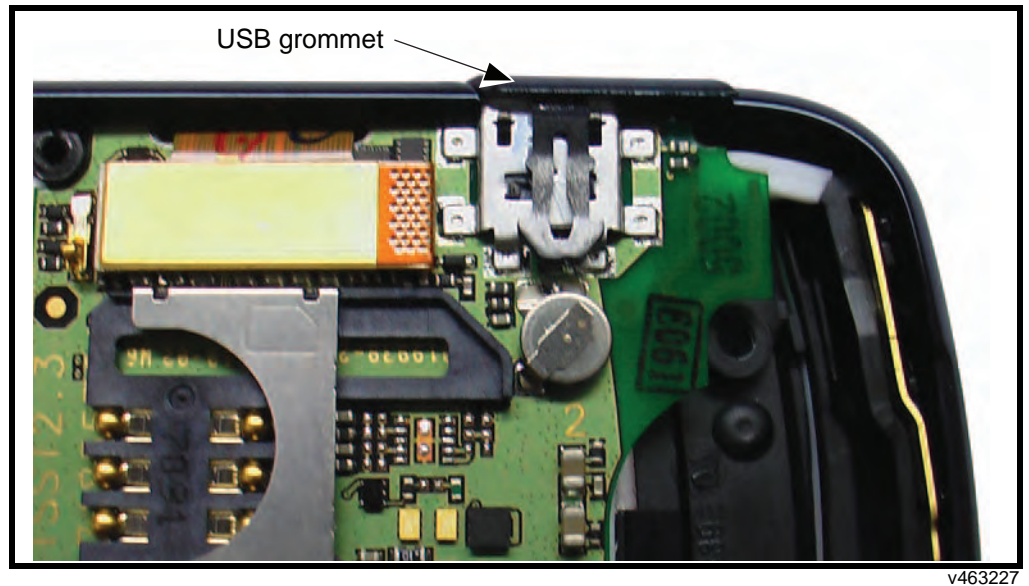
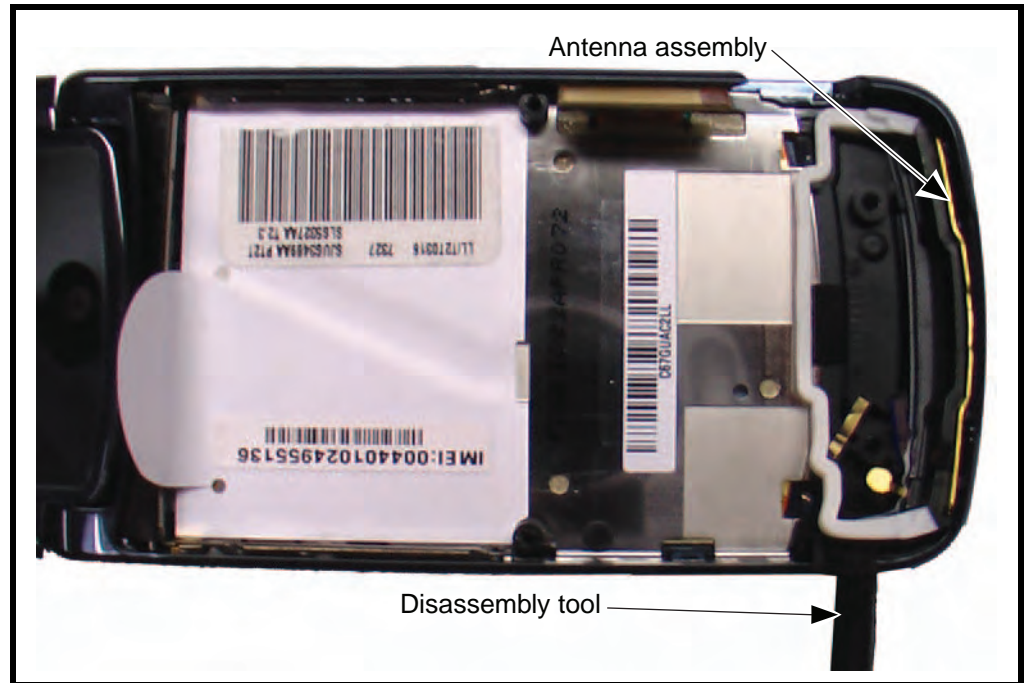

Figure 19. Placing the USB Grommet

7. Re-attach the flex connector to its socket on the transceiver PCB.
8. Replace the rear housing, SIM, battery, and battery cover as described in the procedures.

Removing and Replacing the Antenna

1. Remove the battery cover, battery, SIM, and rear housing assembly as described in the procedures.
2. Use the disassembly tool to release the antenna assembly, as shown in Figure 20.



v470138

Figure 20. Removing the Antenna Assembly

3. Carefully lift the antenna assembly away from the phone.
4. To replace, align the antenna assembly to the phone.

5. Carefully press the antenna assembly into position until the antenna assembly latches snap into position (see Figure 21).

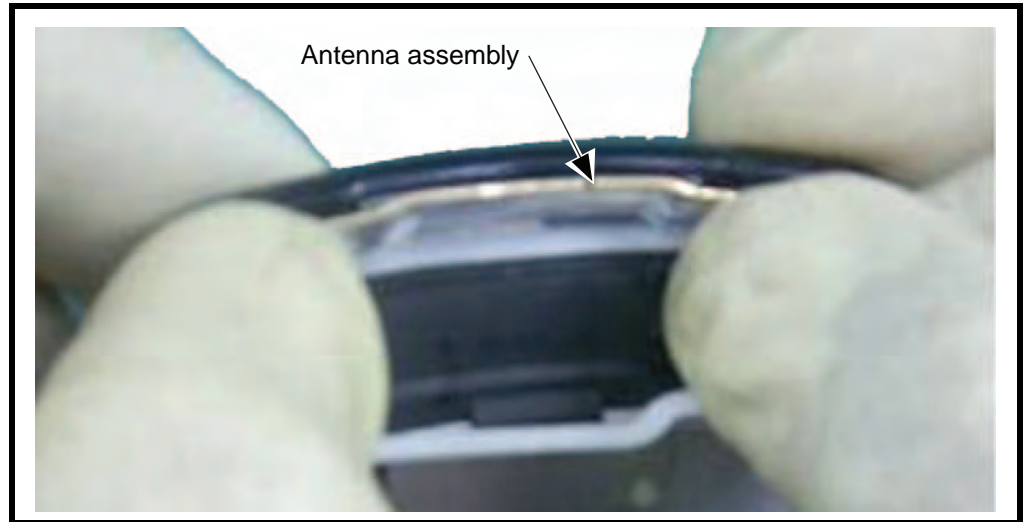

V461018

Figure 21. Installing the Antenna Assembly

6. Replace the transceiver board, rear housing assembly, memory card, battery and battery cover as described in the procedures.

Removing and Replacing the Keypad

1. Remove the battery cover, battery, memory card, rear housing assembly, and transceiver board assembly as described in the procedures.
2. Remove the battery compartment label, as shown in Figure 22.

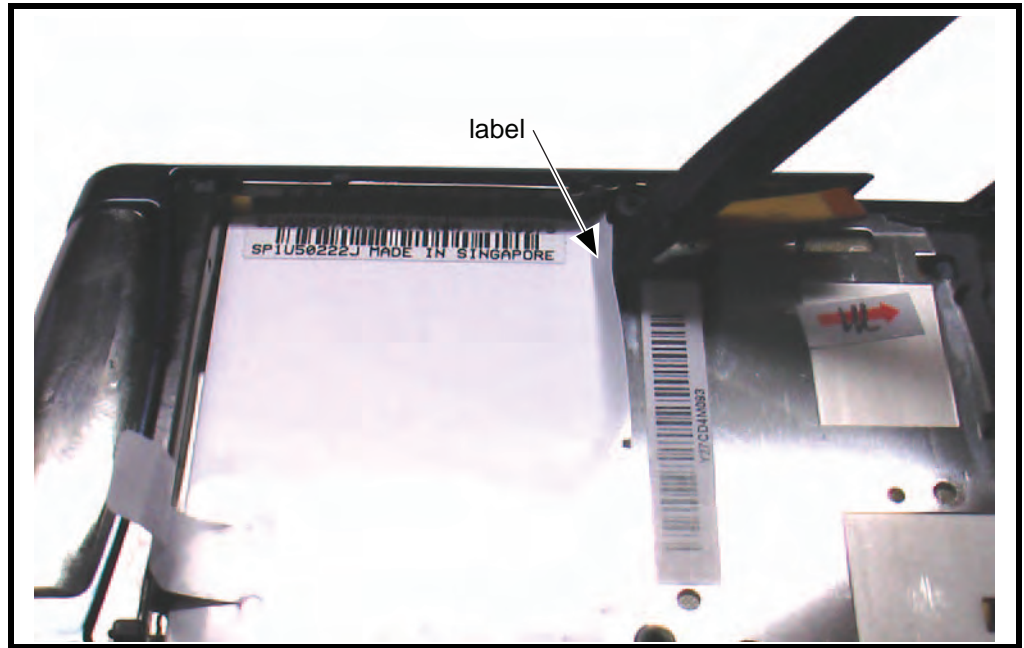

V463228

Figure 22. Removing the Battery Compartment Label

3. Lift one arm of the battery retention chassis (BRC) from between the front housing wall and screw boss.
4. Ensure the bent tabs on the arms are released from the slots in the front housing chassis. Similarly, remove the BRC arm from the other side (see Figures 23 and 24).

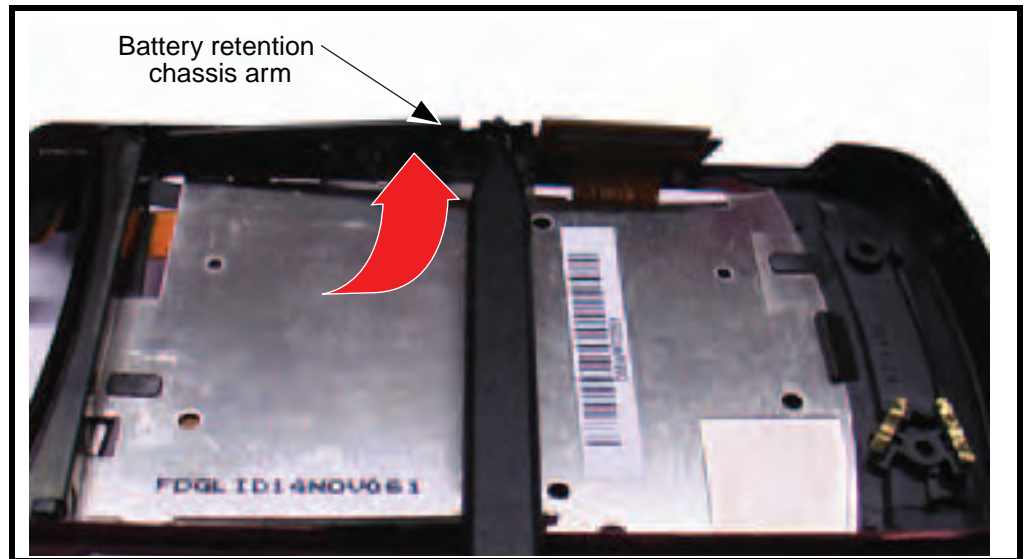

V463229

Figure 23. Removing the Battery Retention Chassis Arm

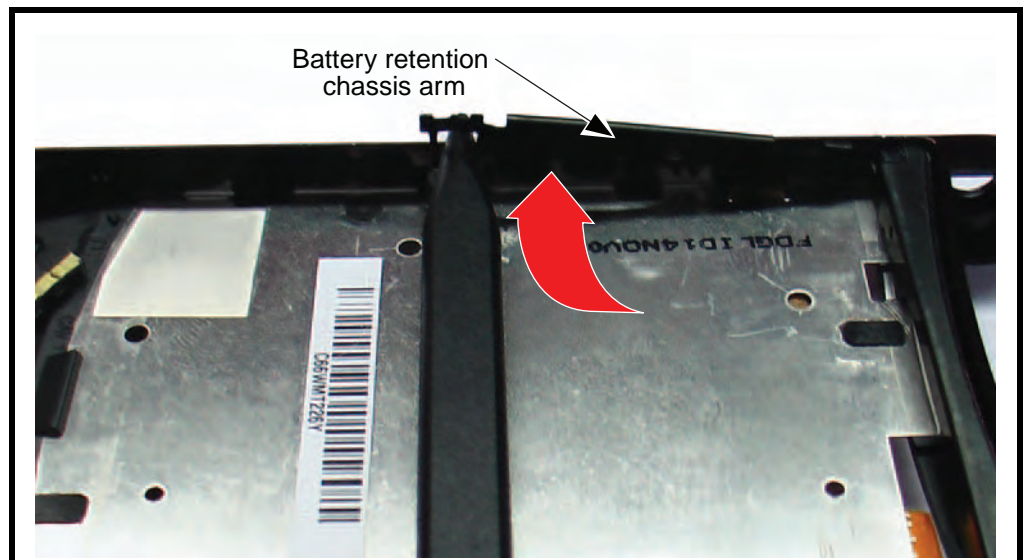

V463230

Figure 24. Removing the Battery Retention Chassis Arm

5. Pull one arm of the BRC to remove the BRC from the front housing (see Figure 25). The top portion of the BRC is adhered to the front housing with

adhesive. Ensure the adhesive is completely removed with the BRC. Discard the used BRC.

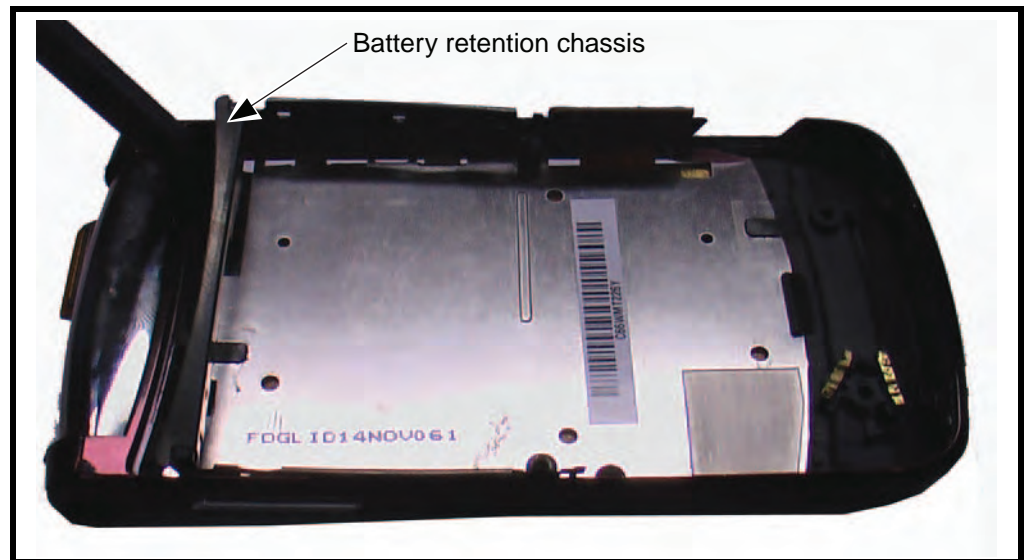

V463231

Figure 25. Removing the Battery Retention Chassis

6. The keypad is secured by 4 bent tabs and 4 snaps (see Figure 26).

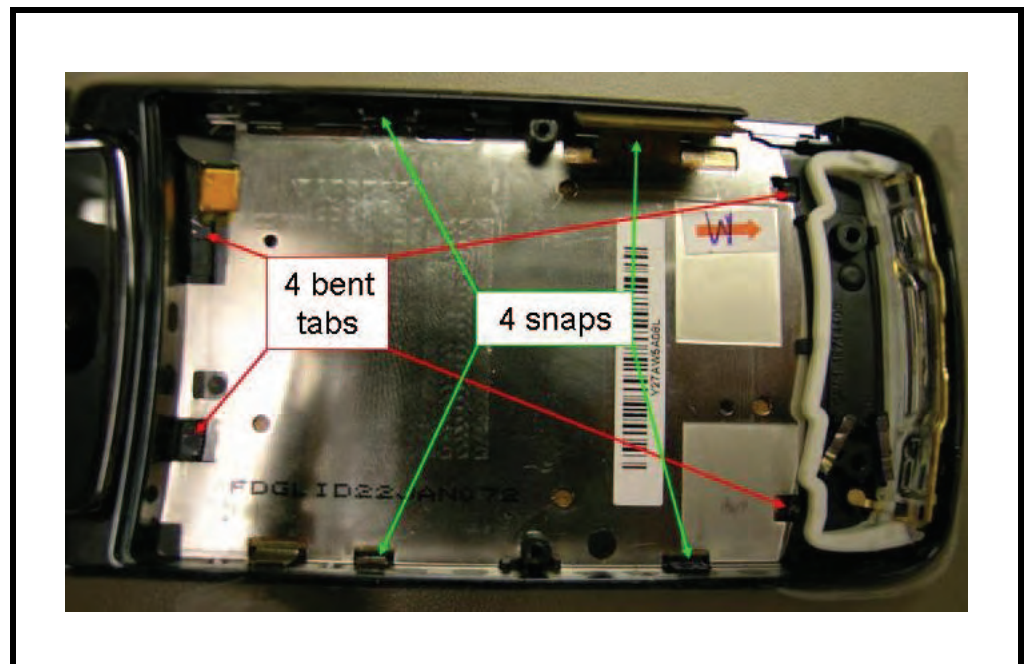

V461034

Figure 26. Location of Keypad Tabs and Snaps

7. Use a small flat tip screw driver to unbend the four tabs (see Figure 26).

8. Use a small flat tip screw driver to release the four side snaps. When the snap releases, press down slightly on the tab to push the keypad away from the front housing to prevent the snap from re-engaging. Extra caution should be taken when releasing the snap behind the keypad flex connector - **DO NOT DAMAGE THE FLEX.**
9. To replace, place the keypad assembly into the front housing (see Figure 27).



Install the keypad carefully to avoid scratching the housing surfaces.



V461034

Figure 27. Placing the Keypad into the Front Housing

10. Ensure that the keypad tabs near the corners and the keypad snaps along the sides of the keypad assembly are inserted carefully and correctly into the front housing.

11. Place front housing into the keypad tab bend fixture and press (see Figure 28).

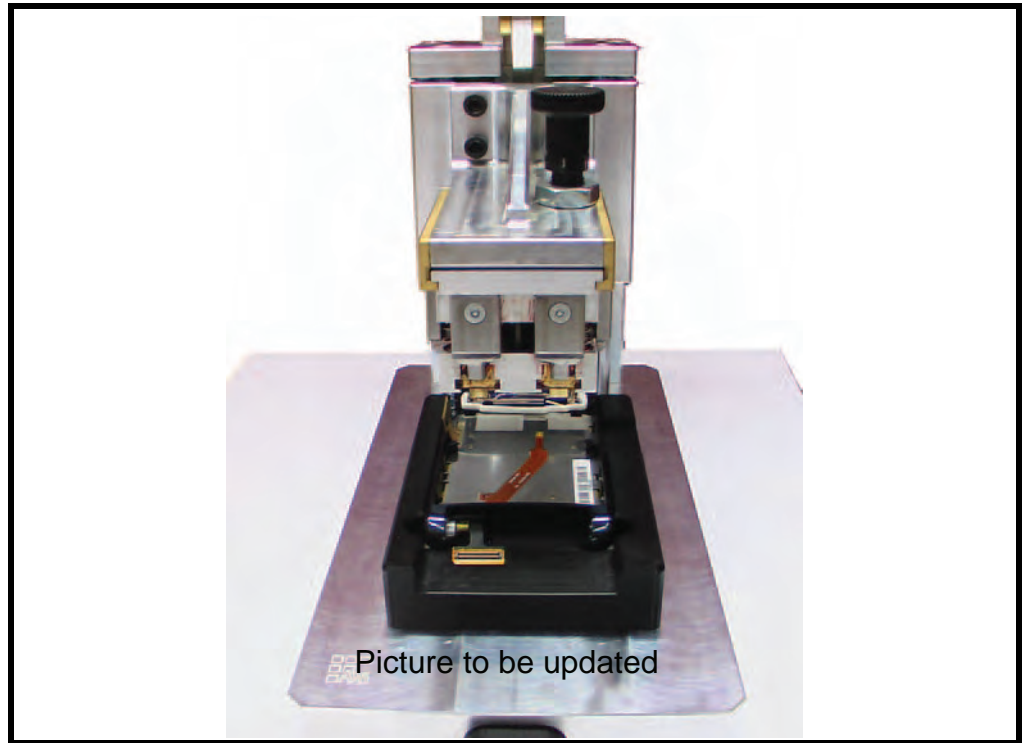

v470132

Figure 28. Keypad Tab Bend Fixture

12. Remove the BRC from the tray and remove the adhesive liner on the top side.
13. Bend the BRC legs inward slightly and install into the flip front assembly (see Figure 29).

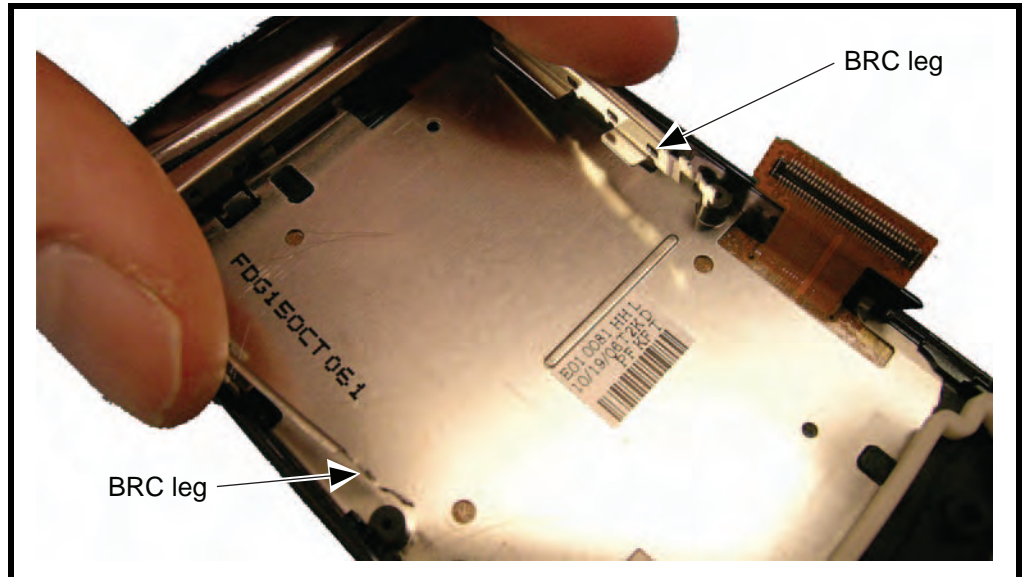

V462430

Figure 29. Installing the Battery Retention Chassis

14. Insert the end of the BRC into the slot between the screw boss and the wall of the front housing (see Figure 30).

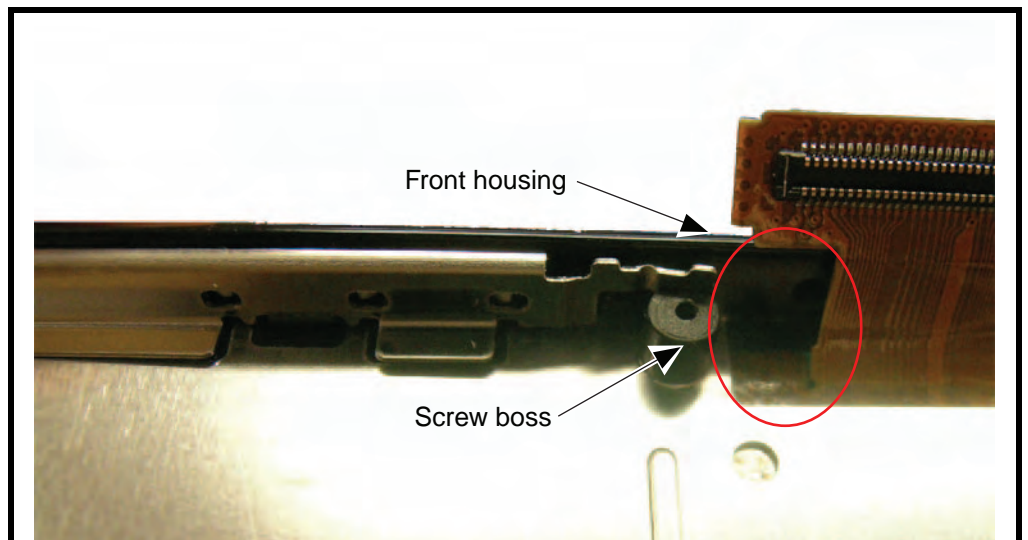

V462432

Figure 30. Installing the Battery Retention Chassis

15. Install the transceiver board assembly, rear housing assembly, SIM, battery, and battery cover, as described in the procedures.

Removing and Replacing the Flip Assembly

1. Remove the battery cover, battery, rear housing, antenna, and transceiver board assembly as described in the procedures.
2. Apply hot air (temperature 400 F) to the bottom of the CLI lens for 10-12 seconds at a distance of 1 inch.
3. Apply hot air (temperature 400 F) to the top of the CLI lens for 8-10 seconds at a distance of 1 inch. Do not apply hot air to the center of the lens.
4. Do not heat the center of the lens.

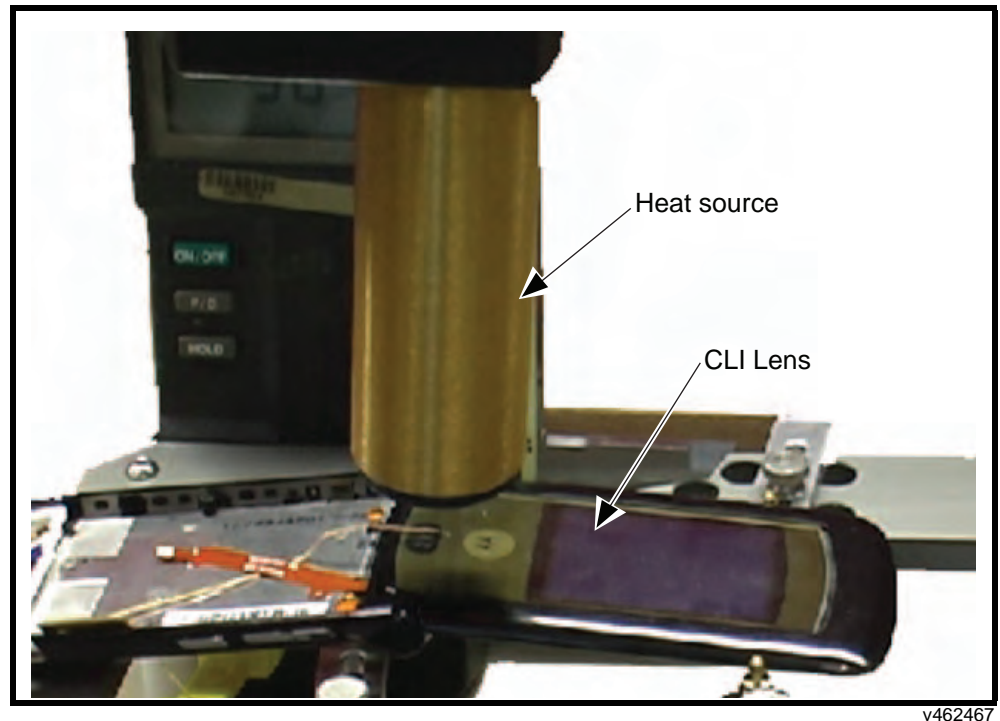

v462467

Figure 31. Heating the CLI Lens



It is NOT necessary to remove the CLI lens assembly to get to the inside of the flip when servicing the main lens, flip inner, or imager flex assembly.

5. Using the black stick, pry the CLI lens up from the nose of the phone. The black stick should be inserted into the gap between the CLI lens and the flip outer at the tertiary porting of the earpiece speaker.



v461040

Figure 32. Prying the CLI Lens

6. Once the end of the CLI lens has been lifted sufficiently, slide the black stick up one edge of the lens to separate the lens from the P-flex. After doing one side repeat the process on the other side.
7. Pull the CLI lens off in the direction of the nose to the imager.
8. If necessary, use the heat gun to loosen the adhesive between the top portion of the lens and the P-flex by directing heat between the lens and the P-flex. Continue to pull on the lens while applying heat. When the CLI lens is removed, discard the lens, as it should not be reused.

- Carefully slide a black stick or comparable tool under the top edge of the main lens just below the horseshoe. Be careful not to damage either the speaker porting mesh or the finish on decorated housings.

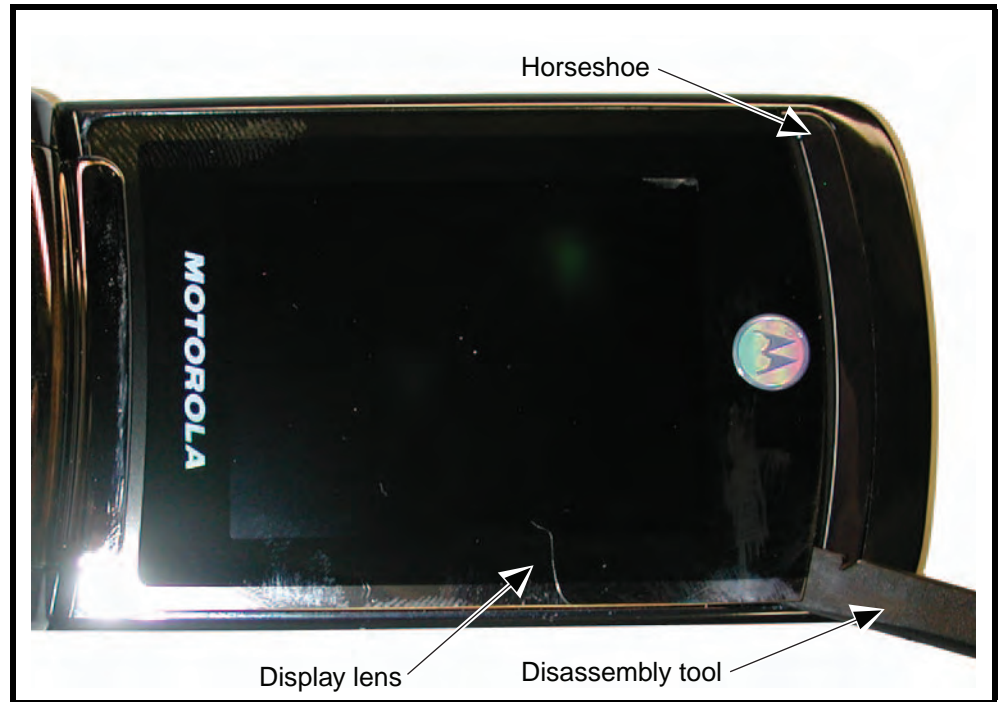

v461035

Figure 33. Removing the Display Lens

- Grasp the main lens and peel off toward the flip barrel. After the main lens is completely removed, discard the lens, as it should not be reused.

11. Use a driver with T5IP bit to remove the four flip inner screws.

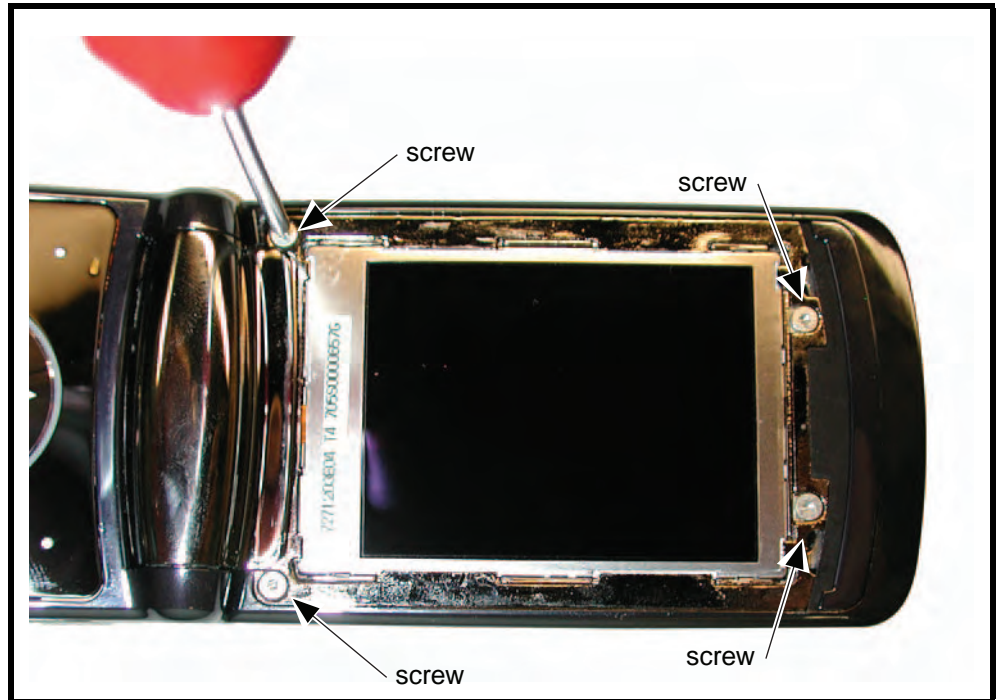

v461036

Figure 34. Removing the Flip Inner Screws

12. Gently pry the flip inner off by pulling the left side of the flip inner up and rotating to the right side to release the snap at the right knuckle.

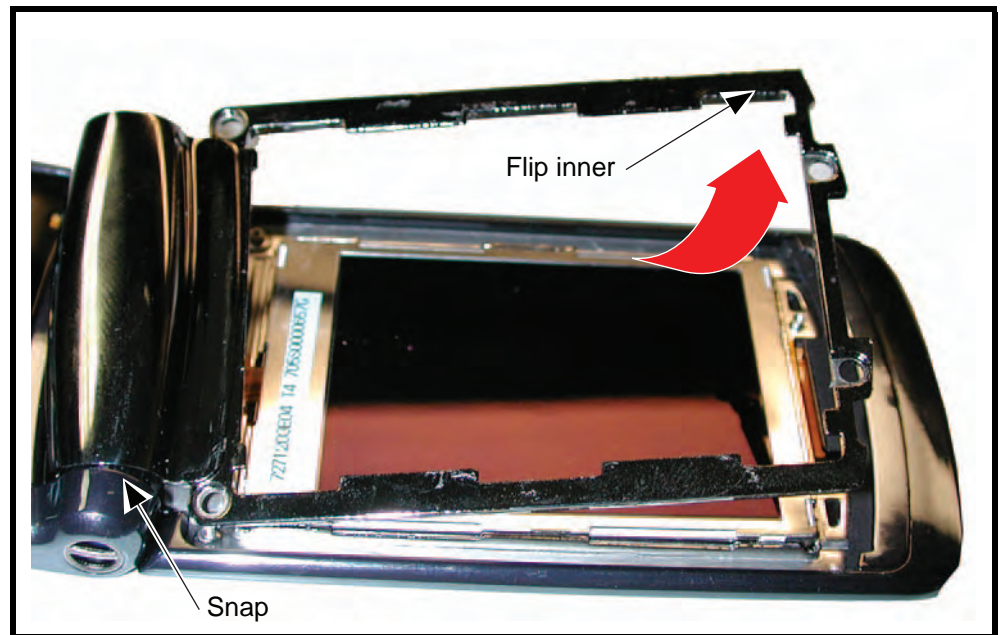

v461037

Figure 35. Removing the Flip Inner



The flexible printed cable (FPC) (flex) is easily damaged. Exercise extreme care when handling.

13. Remove the earpiece cover.

14. Disconnect the P-flex by lifting on the flex using a black stick or similar tool. It is important to disconnect the flex carefully to prevent damage to the receptacle pins (see Figure 36).

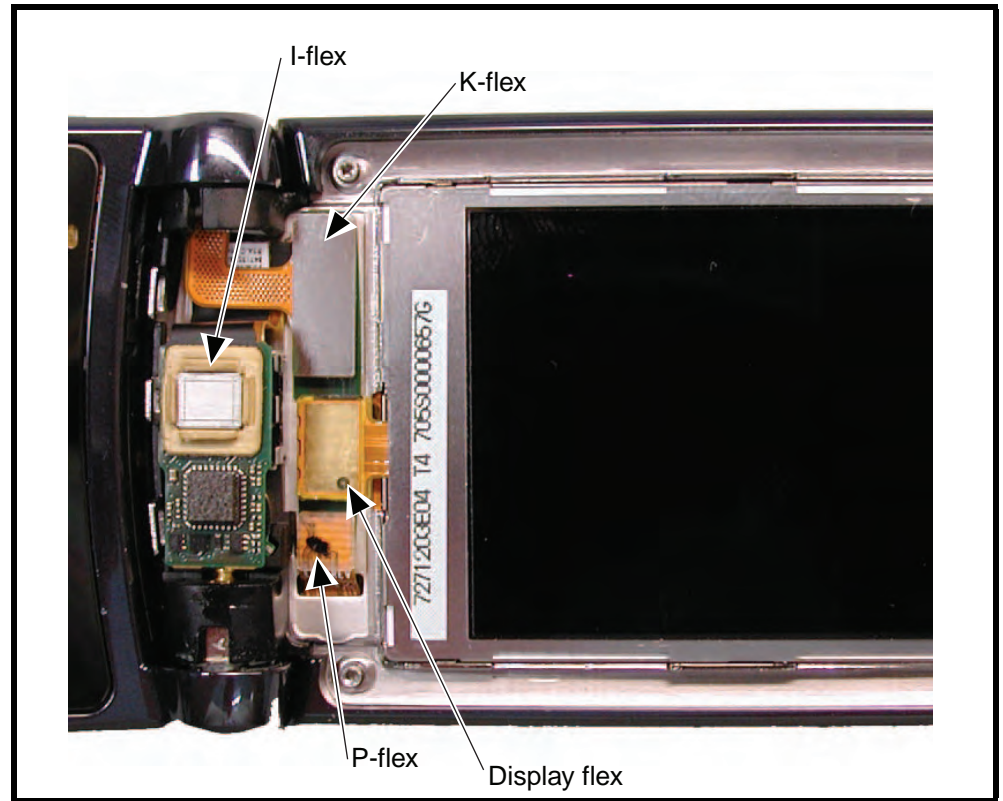

v461038

Figure 36. Removing the Flex Connectors



The flexible printed cable (FPC) (flex) is easily damaged. Exercise extreme care when handling.

15. Disconnect the 30 pin display flex connector (see Figure 36).
16. Disconnect the 54 pin K-flex connector (see Figure 36).
17. Disconnect the 10 pin P-flex connector (see Figure 36). Remove the connector at the long edge.
18. Remove the I-flex by lifting the imager out of the socket. Ensure the I-flex clears the alignment post below the K-flex tail. Lift the I-flex out so it is free of the K-flex tail, then slide the I-flex out from under the display flex tail.

19. Peel back the P-flex from the perimeter of the display bezel.

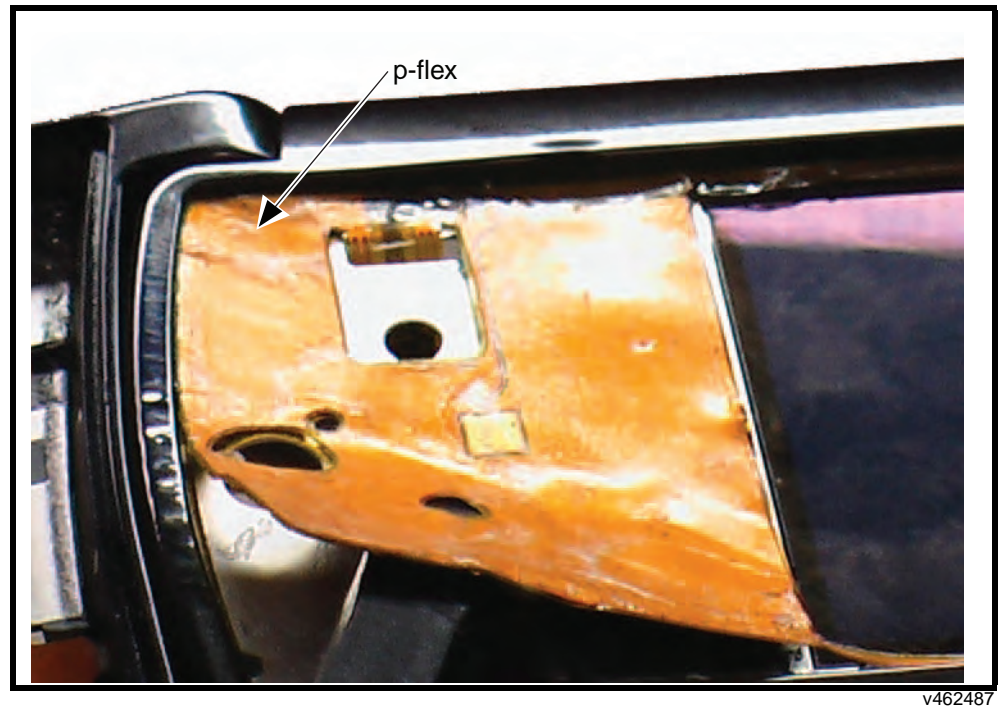

Figure 37. Removing the P-Flex



The flexible printed cable (FPC) (flex) is easily damaged. Exercise extreme care when handling.

20. Push the tandem display away from the flip outer by pressing on the CLI display. Be careful not to put excessive pressure on the display. Once the display is free from the flip outer, remove excess adhesive from the bezel so the display can be reused.

21. Use the disassembly tool to remove the vibrator assembly (see Figure 38).

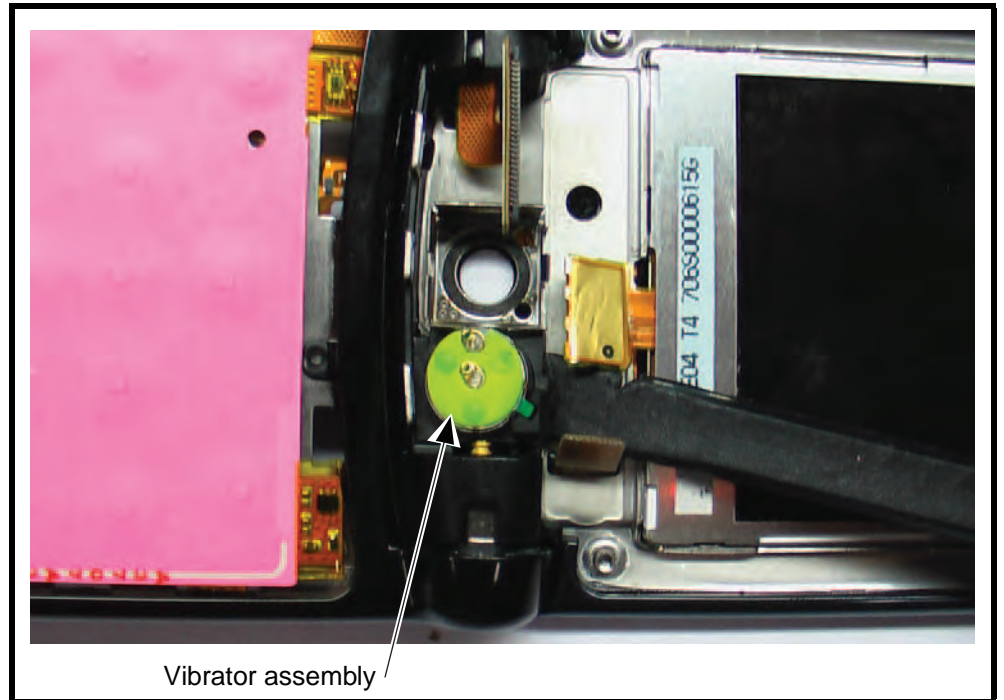

v470139

Figure 38. Removing the Vibrator Assembly

22. Separate the horseshoe assembly from the flip assembly, as shown. Remove the horseshoe assembly from the flip (see Figure 39).

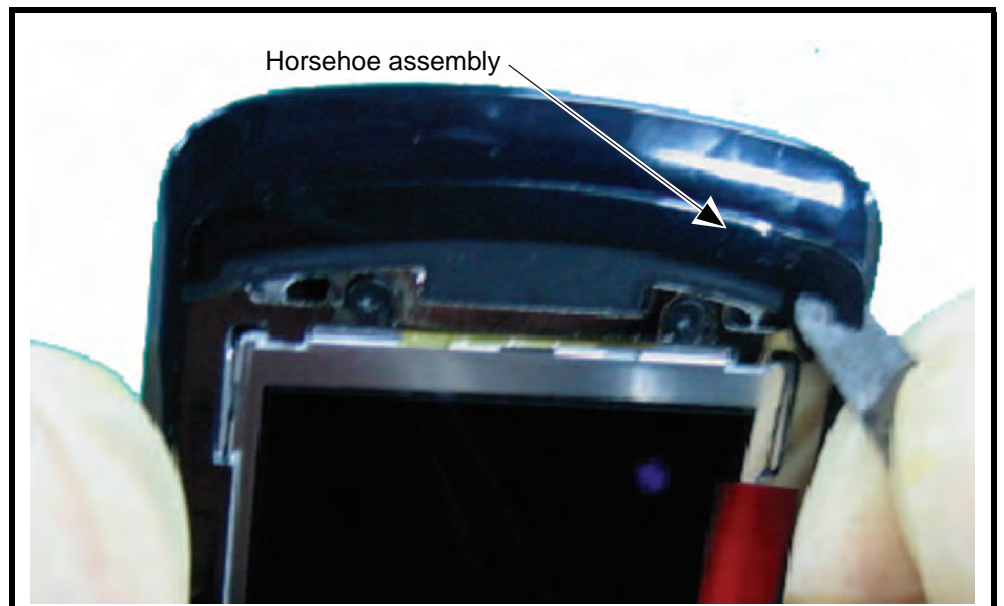

v462490

Figure 39. Removing the Horseshoe Assembly

23. Slide hinge tool over end of hinge and pull away from outside of phone. This will release the front housing from the flip outer.

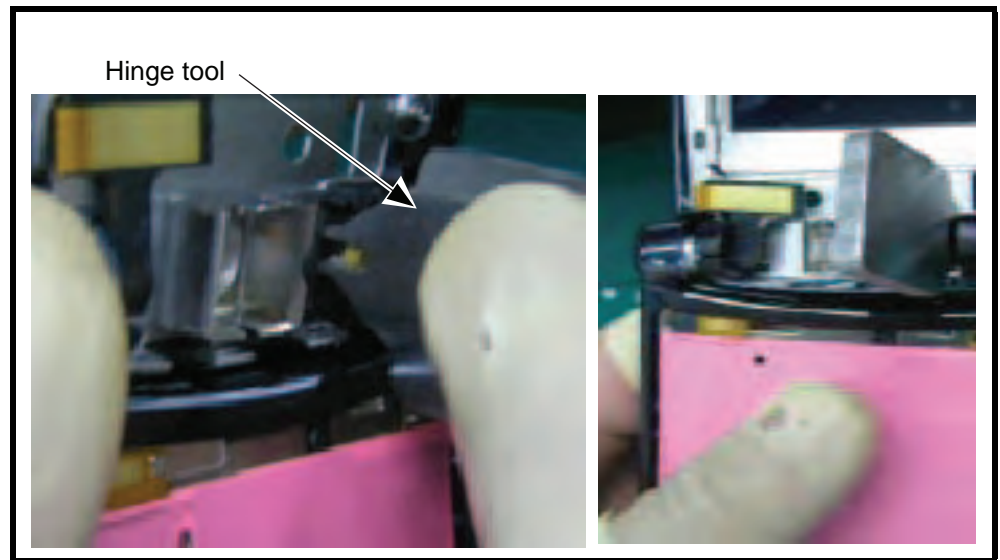

Figure 40. Removing the Flip Hinge

24. Remove the lanyard collar and hinge.

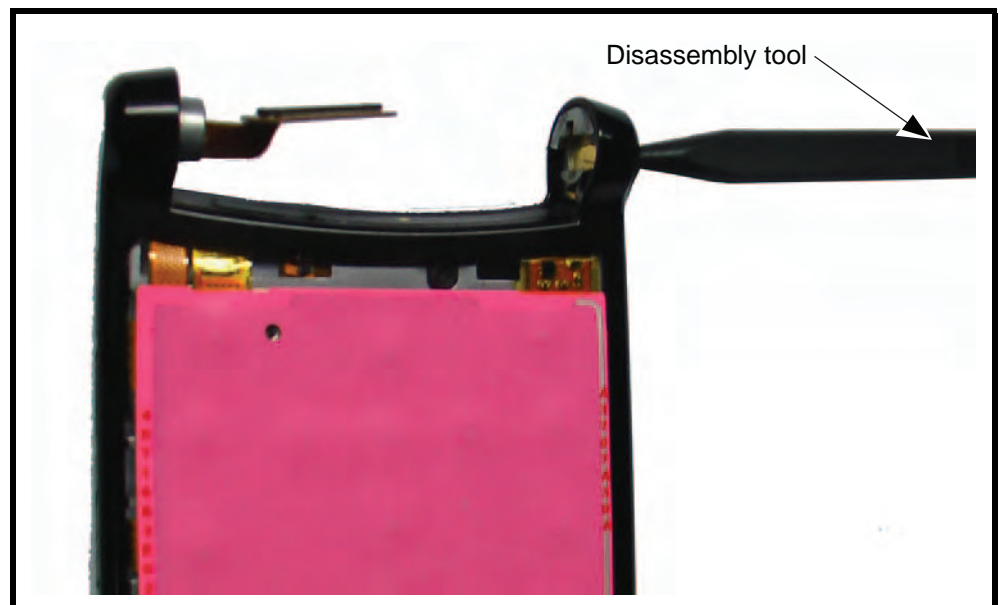
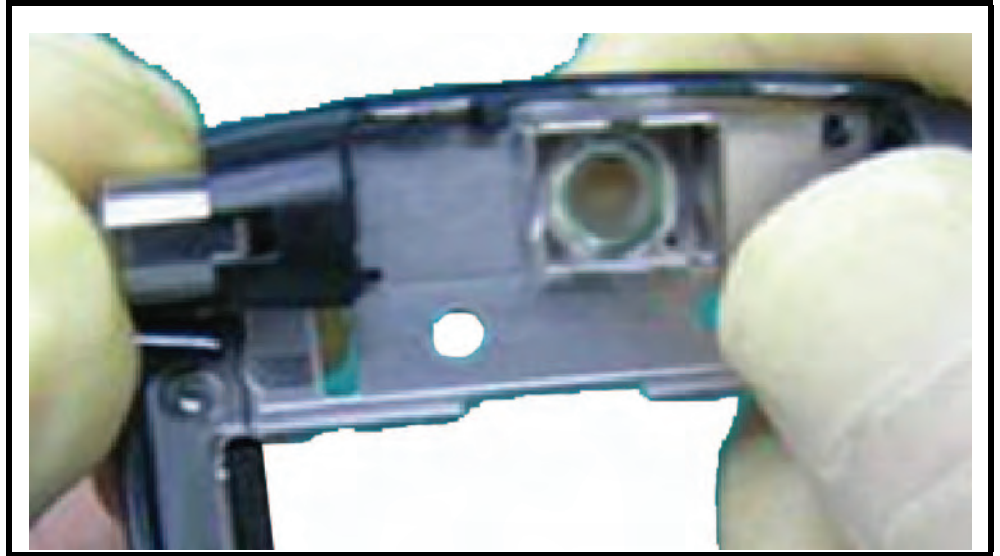

Figure 41. Removing the Lanyard Collar



v462492

Figure 42. Removing the Sleeve

25. Insert the disassembly tool under the k-flex to separate it from the front housing. Peel the k-flex by hand to remove it from the front housing (see Figure 43).

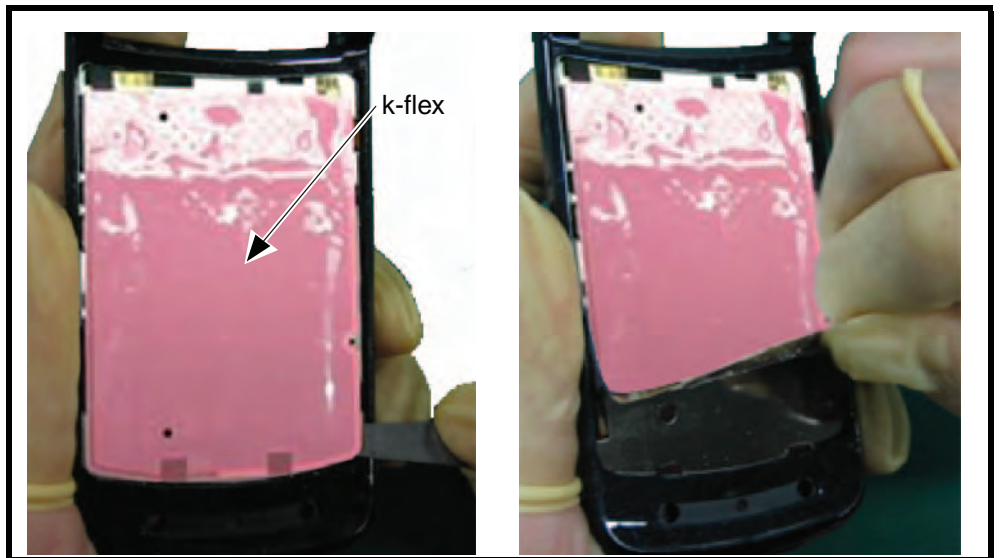

v462515 v462516

Figure 43. Removing the K-Flex

Assemble the Flip

Only a keypad flex with the EGC1702 treatment must be used.



v469264

Figure 44. EGC1702 Treated Keypad Flex

1. Place the front housing into the fixture. Use the alignment pins to align the front housing to the fixture.
2. Peel off the liner on the left side of the keypad flex.

3. Protect the light sensor and hall effect sensor on the new K-Flex by covering them with insulating tape. Do not place the tape on the pink portion of the K-flex (see Figure 45).

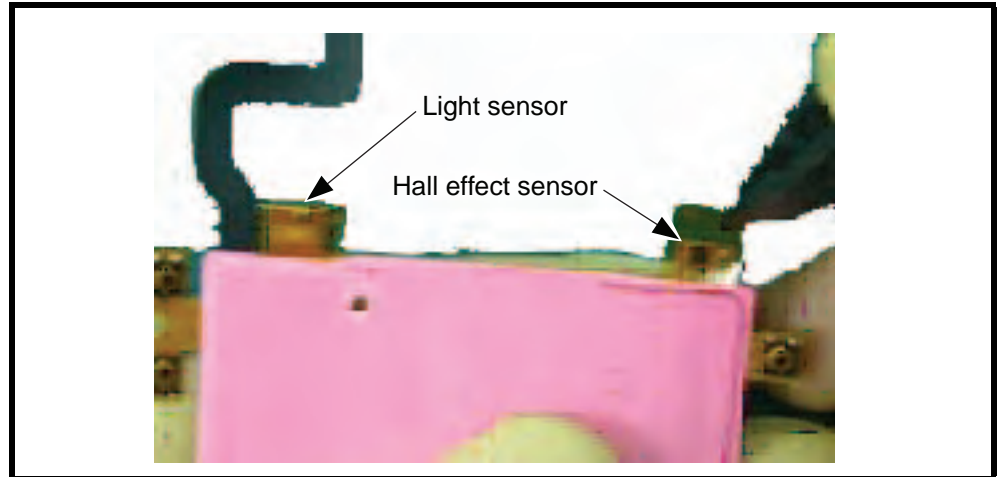

v462522

Figure 45. Protecting the K-Flex Sensors

4. Guide the connector through the housing opening during assembly. Use extreme care when bending the flex.
5. Pre bend the left element to a 90 degree angle.

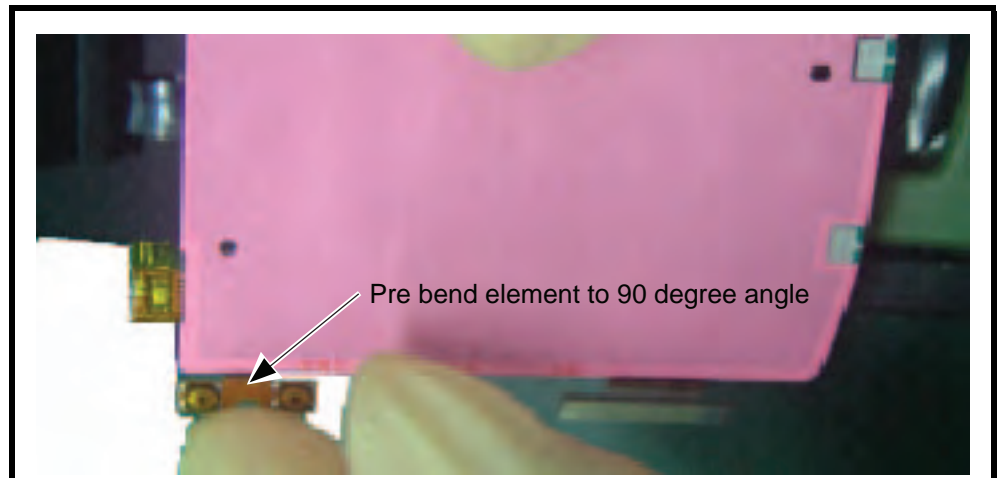

v462528

Figure 46. Bending the K Flex Left Element

6. Insert the K-flex connector and left element into the front housing.
7. Peel away the liner on the right side of the K-flex.
8. Bend the right element to a 90 degree angle.

9. Place the front housing into the service fixture.



v473809

Figure 47. Front Housing Assembly in the Service Fixture

10. Insert the right side of the K-flex into the front housing.
11. Align and then stick the K-flex onto the front housing. Ensure alignment features are used. Press the K-flex at the corners to ensure proper adhesion to the front housing.
12. Remove the front housing from the fixture and install the side keys.

13. Place the housing sleeve to the front housing assembly. Ensure there is no damage to the K-flex. Press the housing sleeve into place in the front housing.



v462530

Figure 48. Installing the Housing Sleeve

14. Inspect the assembly before proceeding to the next step.
15. Insert the front housing assembly into the keypad flex press fixture.
16. After using the press, remove the front housing assembly from the press fixture and inspect for damage or dents.

Assemble the Camera Gasket and Water Label

1. Peel the liner from the camera gasket and place the camera gasket into the fixture with the adhesive side facing upwards.
2. Place the flip outer assembly. Use the fixture to correctly align the outer assembly.

3. Place the water detect label and attach it to the camera shield.

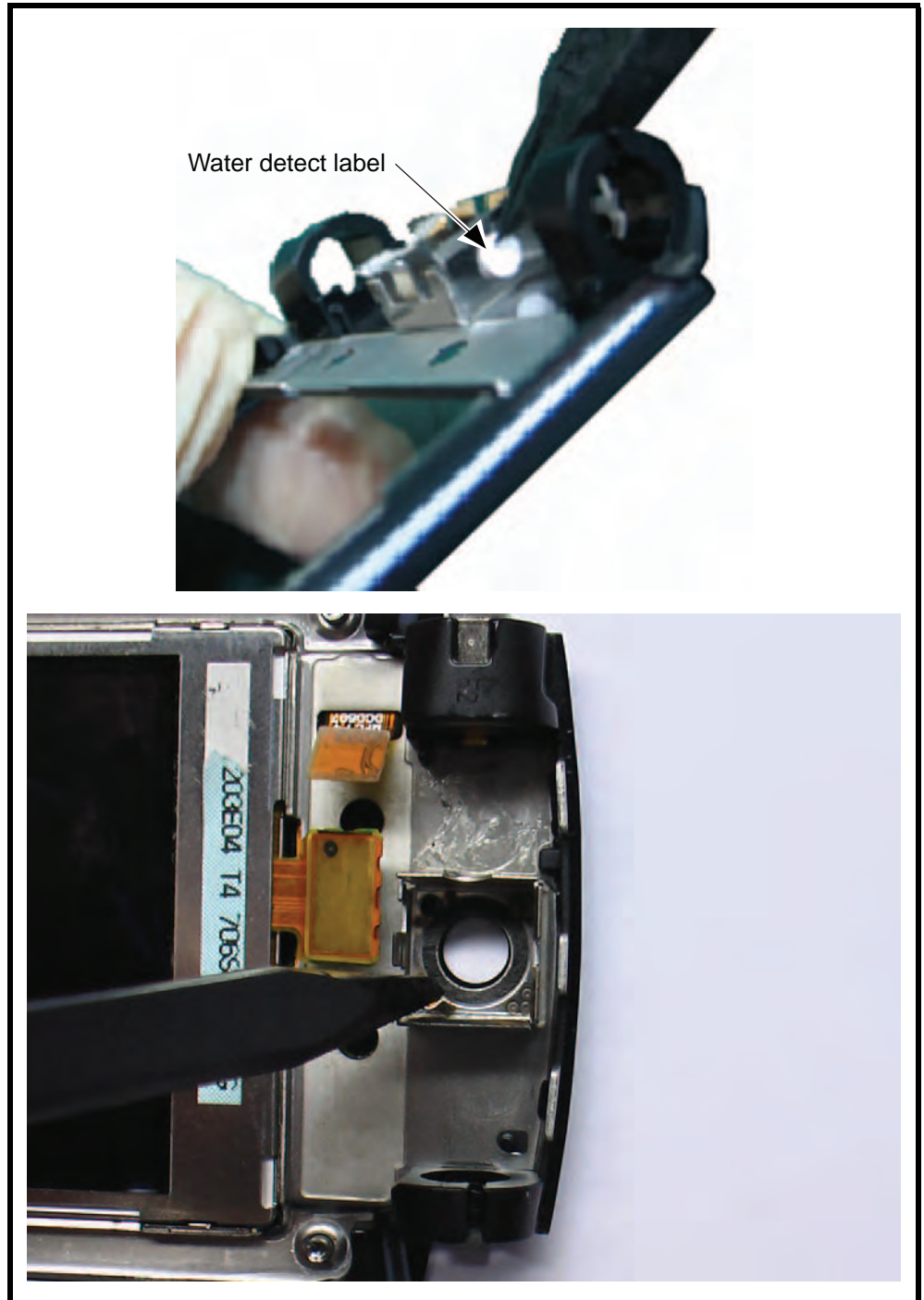

v470168, v462533

Figure 49. Installing the Water Label

Assemble the Hinge

1. Insert the flip hinge cam into the flip outer assembly. The hinge center must remain horizontal (see Figure 50).

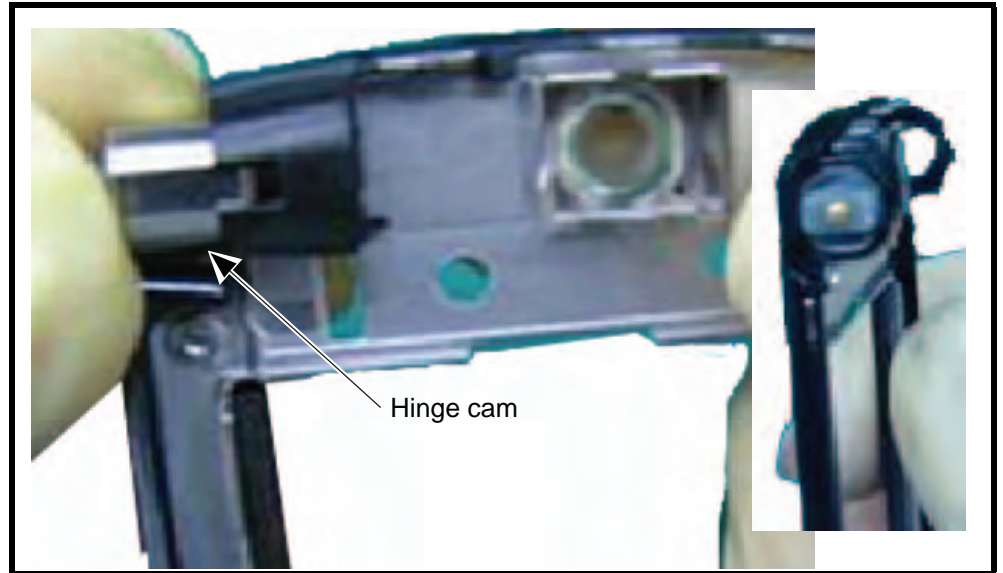

v462534 v462535

Figure 50. Installing the Flip Hinge Cam

2. Press the hinge into the flip outer.

Lubrication

1. Apply 3.5 mg of lubricating grease on both sides of the hinge mechanism.

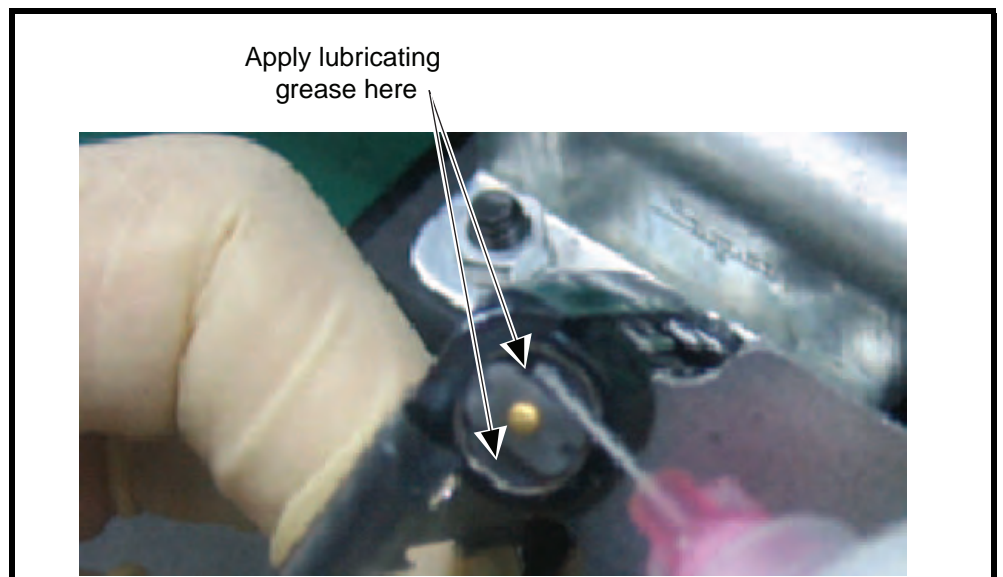

v462536

Figure 51. Lubricating the Flip Hinge

Assembly of Flip to front housing.

1. Assemble flip outer assembly to the front housing.

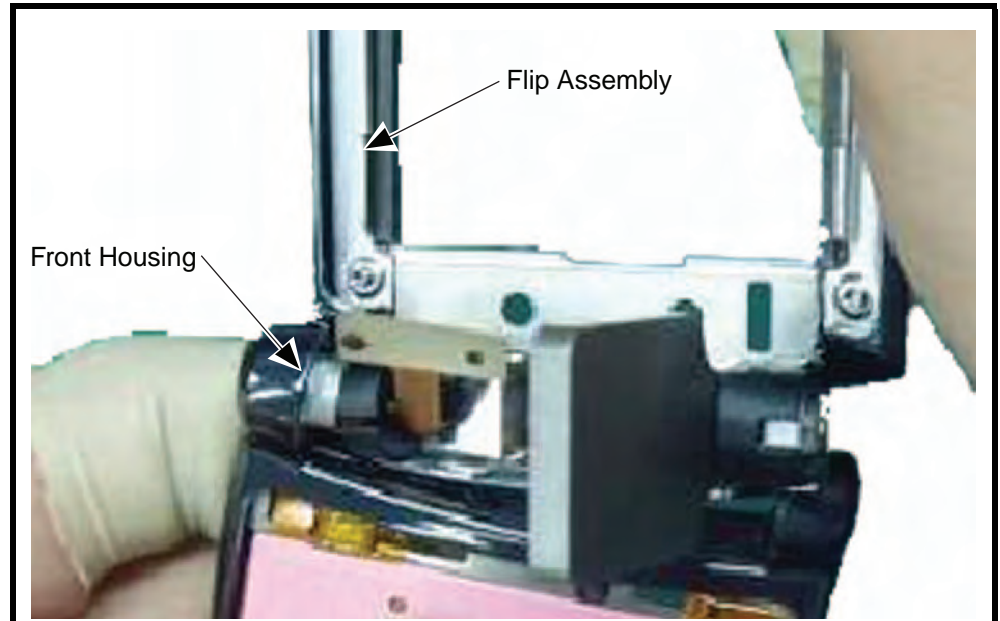

v462539

Figure 52. Installing the Flip Assembly

2. Insert flex into flip outer housing.
3. Align the hinge with the opening in the front housing.

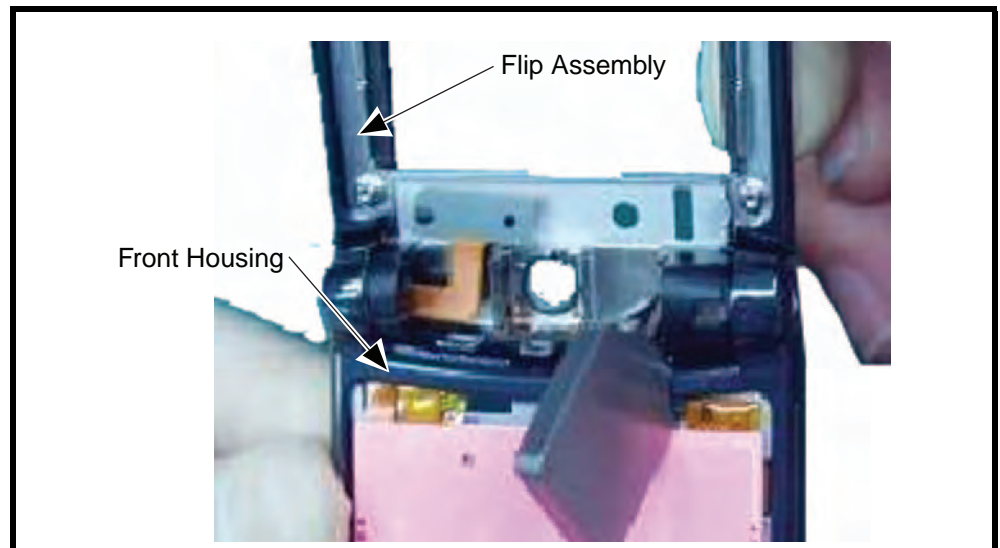

v462540

Figure 53. Aligning the Flip Assembly to the Front Housing

4. Remove the hinge tool.

5. Check flip for proper movement.

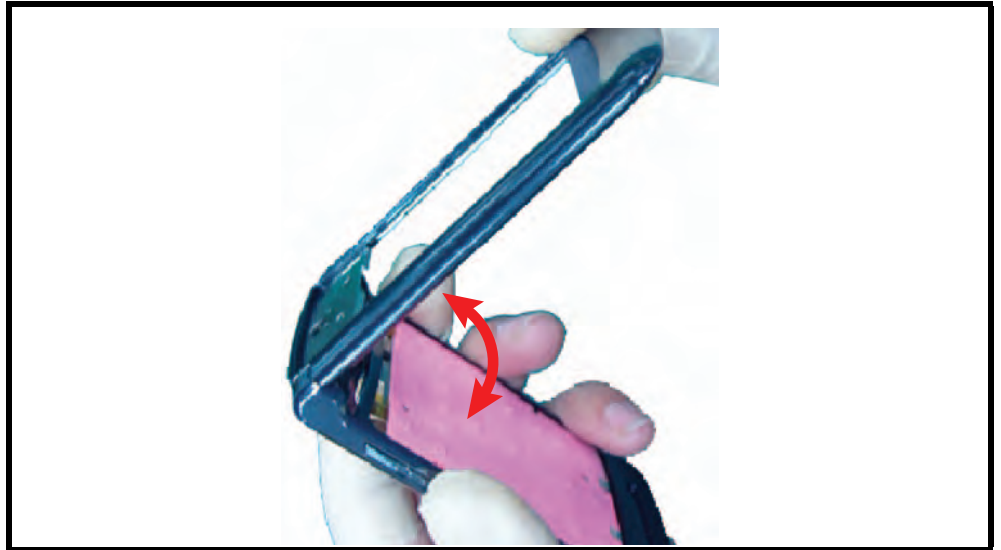

v462541

Figure 54. Inspecting the Flip Assembly

Vibrator Assembly

1. Assemble the vibrator to the vibrator grommet. Vibrator and vibrator grommet must be aligned, as shown.

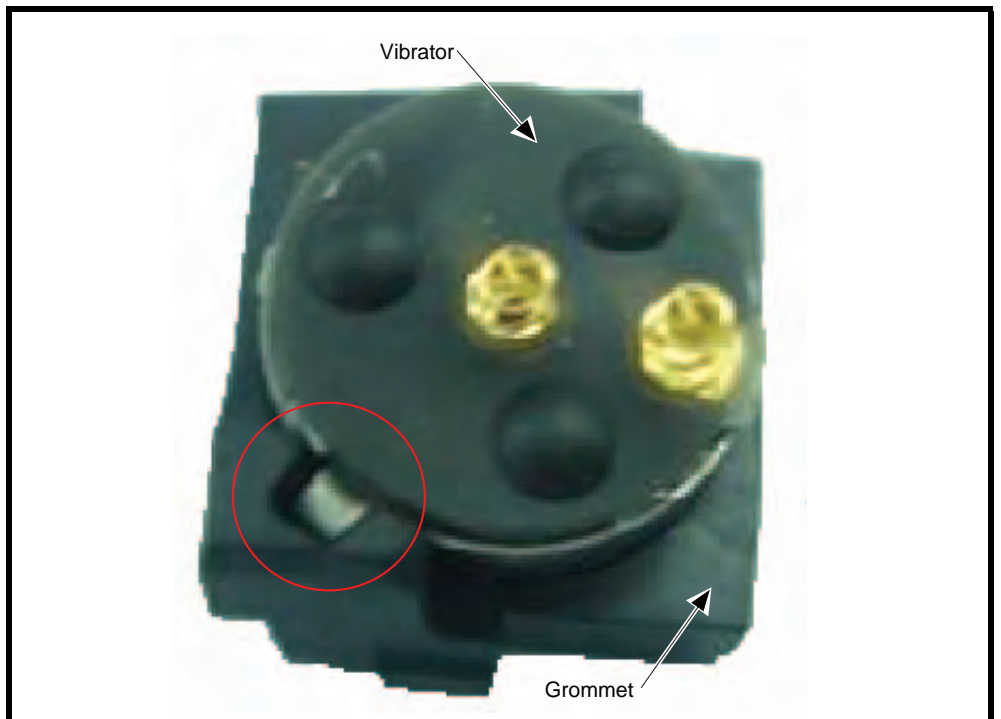

v462578

Figure 55. Installing the Vibrator Grommet

2. Peel away the vibrator adhesive and attach it to the vibrator assembly.
3. Place the vibrator assembly into the flip assembly. The vibrator springs should be on the right side of the vibrator assembly.



v462578

Figure 56. Installing the Vibrator Assembly

I-Flex and Display Assembly



Only a keypad flex with the EGC1702 treatment must be used.

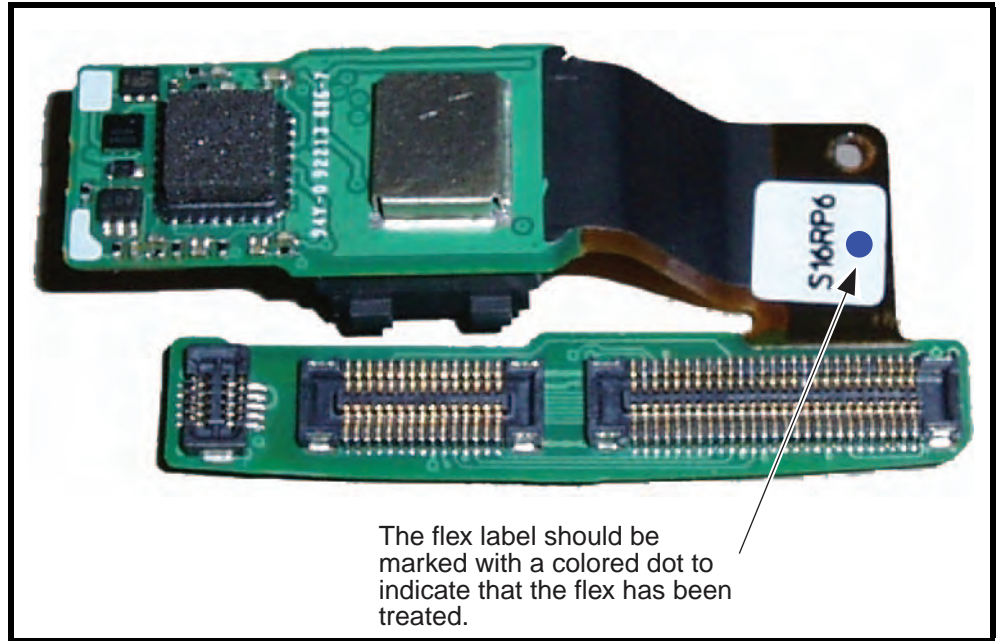

v470101

Figure 57. EGC1702 Treated Imager Flex

1. Connect the imager flex assembly to the LCD.

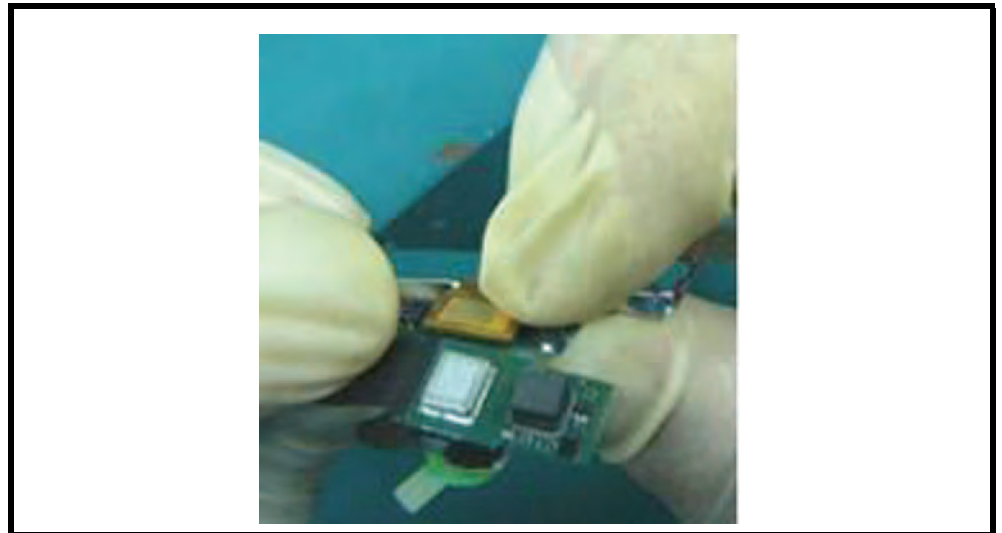

v470099

Figure 58. Connecting the Imager Flex Assembly

2. Peel away the liner from the camera, camera gasket and the LCD.
3. Place the LCD assembly into the flip assembly.
4. Connect the k flex connector.
5. Clean dust and foreign matter from the LCD and display lens with an ionized air gun.

P-Flex Assembly and CLI Lens

1. Peel the liner away from the speaker.

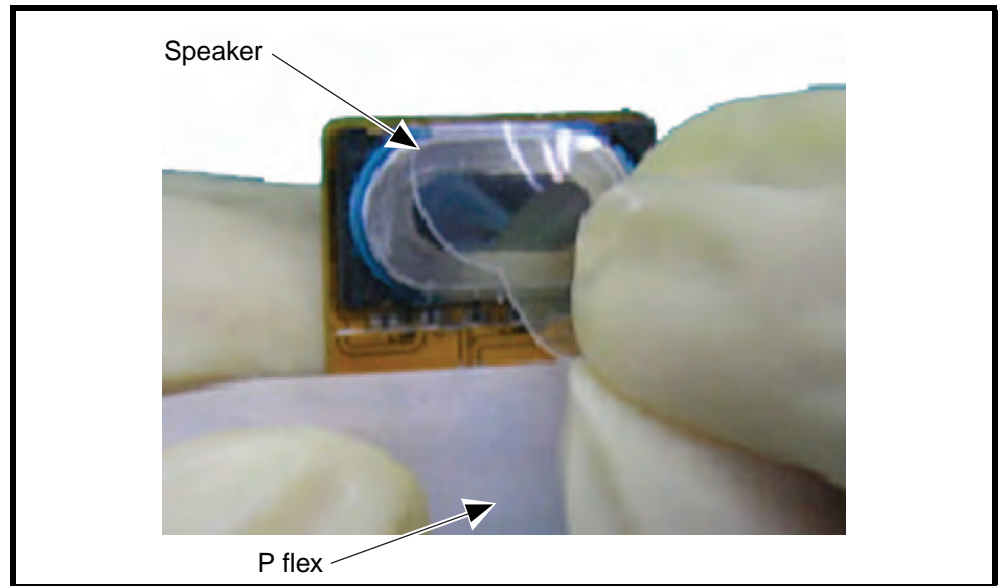
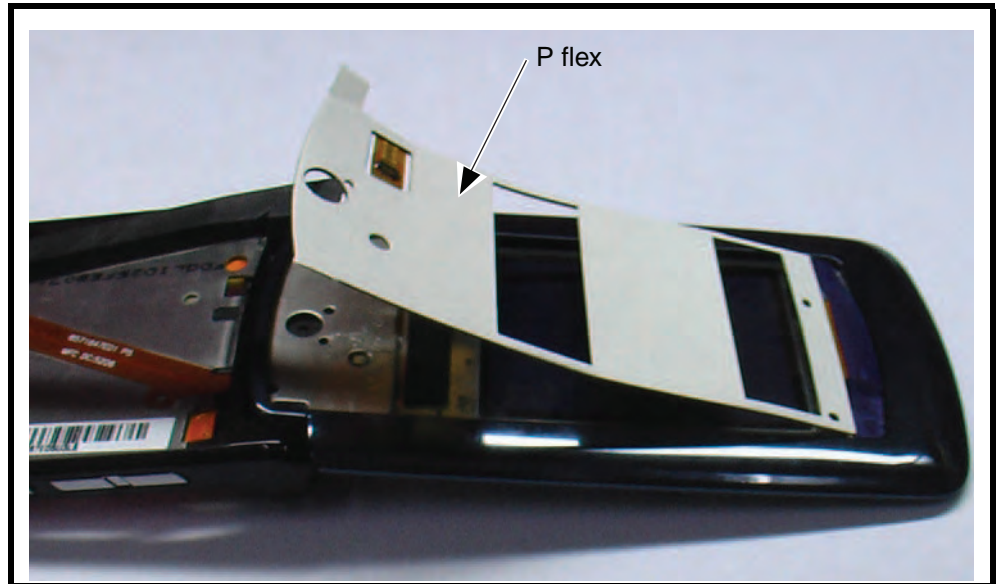

Figure 59. Preparing the Speaker

v462543

2. Remove the P-Flex bottom liner and insert. Ensure the P-Flex connector passes through the housing.



v470104

Figure 60. Installing the Speaker

3. Align the P-flex using 3 holes on the housing to align and adhere the P-flex to the flip assembly.

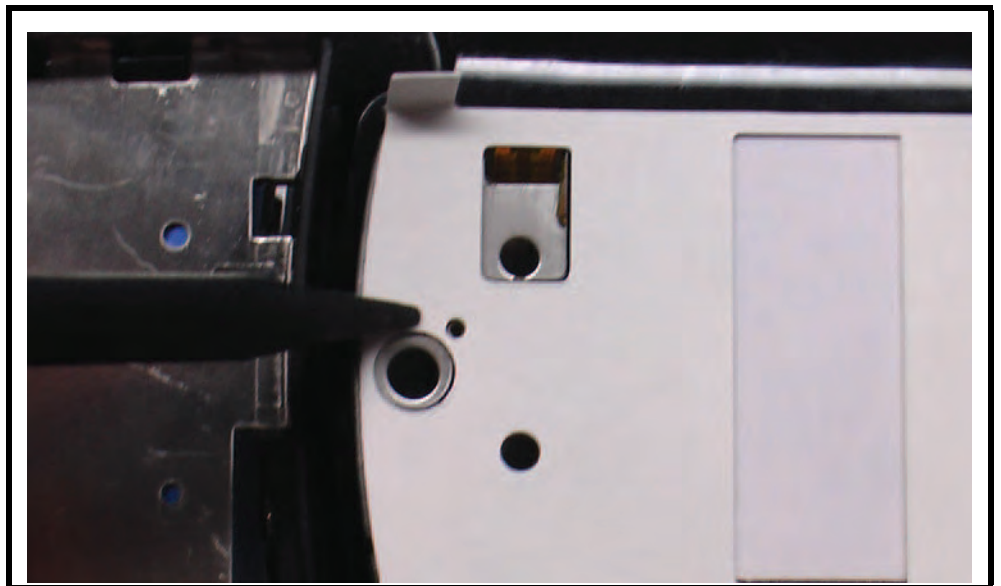

v470103

Figure 61. Attaching the P-Flex

4. Remove the top liner from the CLI lens.
5. Align the CLI lens to the flip outer assembly.

6. Place the flip assembly press fixture to attach the CLI lens to the flip assembly.

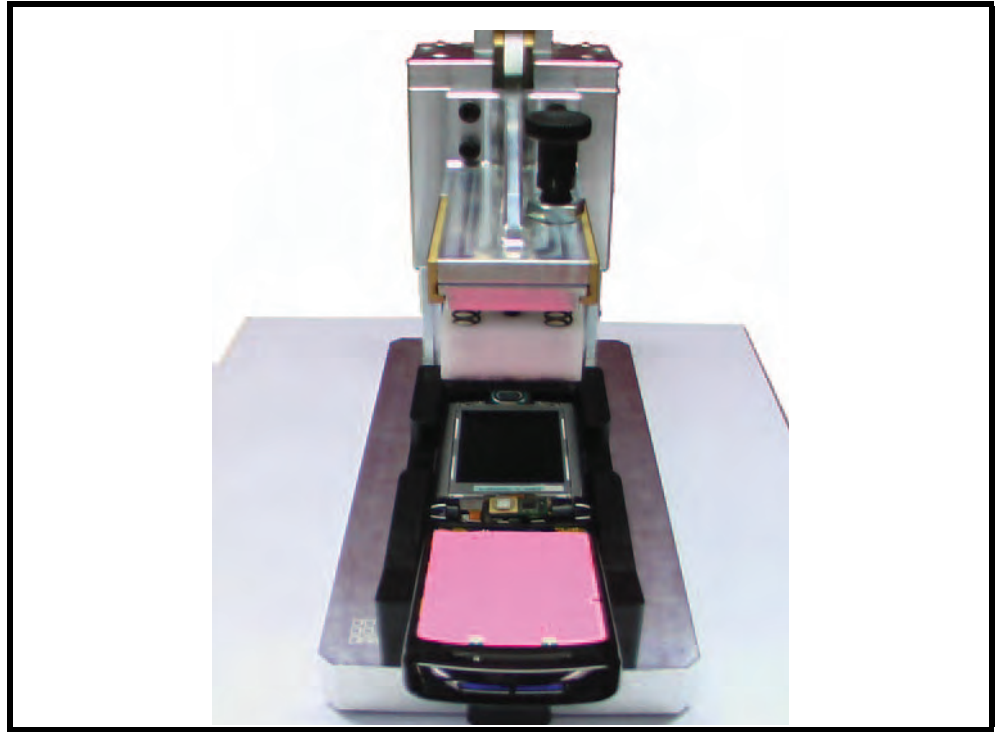

v470112

Figure 62. CLI Lens Press Fixture

7. Close the press fixture and hold for 16 seconds.

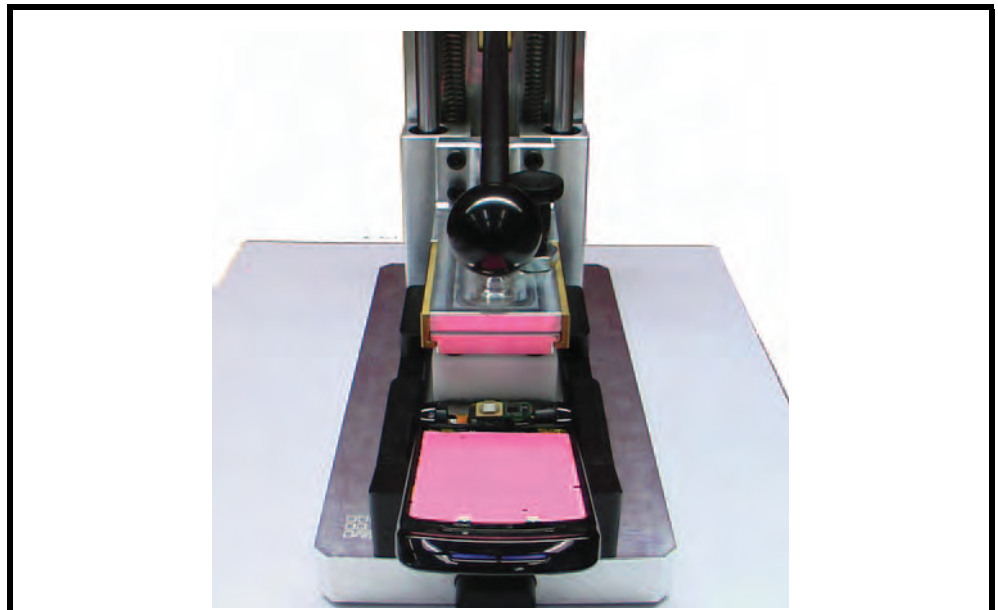

v470106

Figure 63. CLI Lens Press Fixture

8. Open the fixture and remove the flip assembly.
9. Connect the P-Flex to the I-Flex.

Earpiece Cover

1. Insert the earpiece cover into the fixture with the front side facing upward.

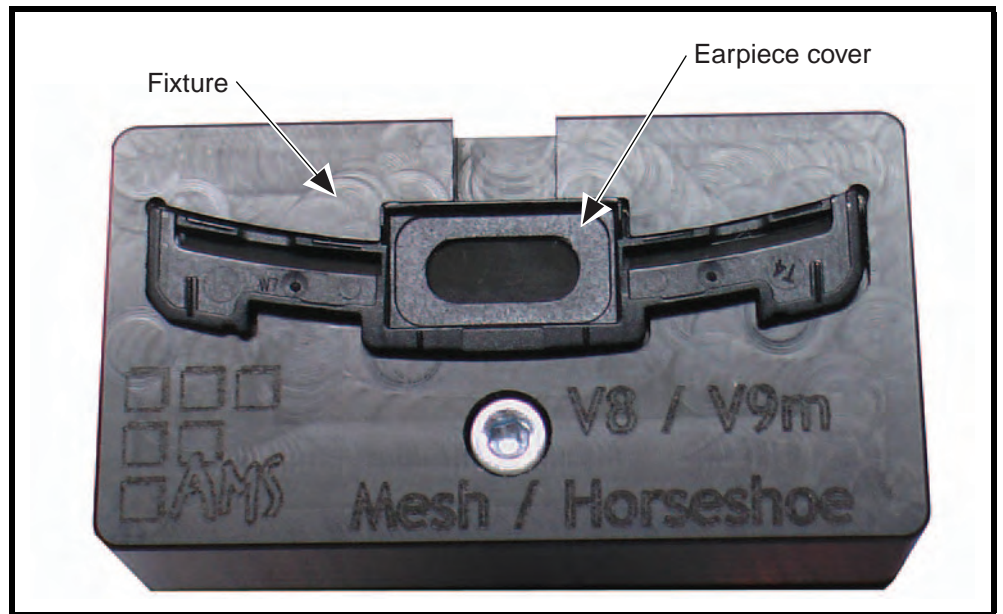

v473810

Figure 64. Earpiece Cover in the Fixture

2. Activate the press fixture to adhere the speaker mesh to the earpiece cover.
3. Remove the earpiece cover from the fixture and inspect earpiece cover for damage.

Magnet

1. Apply 1.4 mg +/- .2 mg glue to the flip inner assembly.

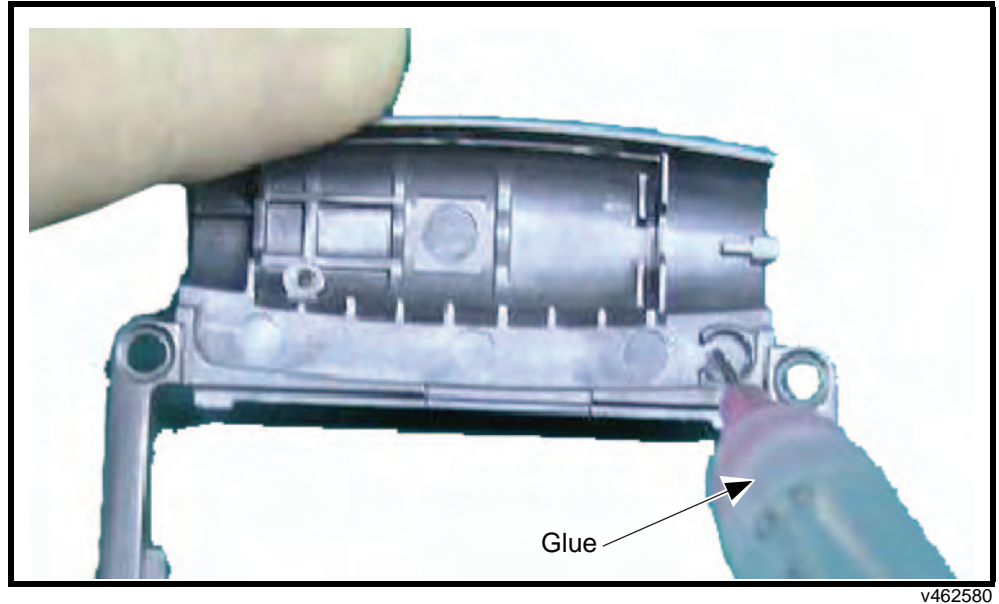

Figure 65. Installing Magnet Glue to the Flip Inner Assembly

2. Place the magnet onto the flip inner assembly. Wipe away any excess glue.

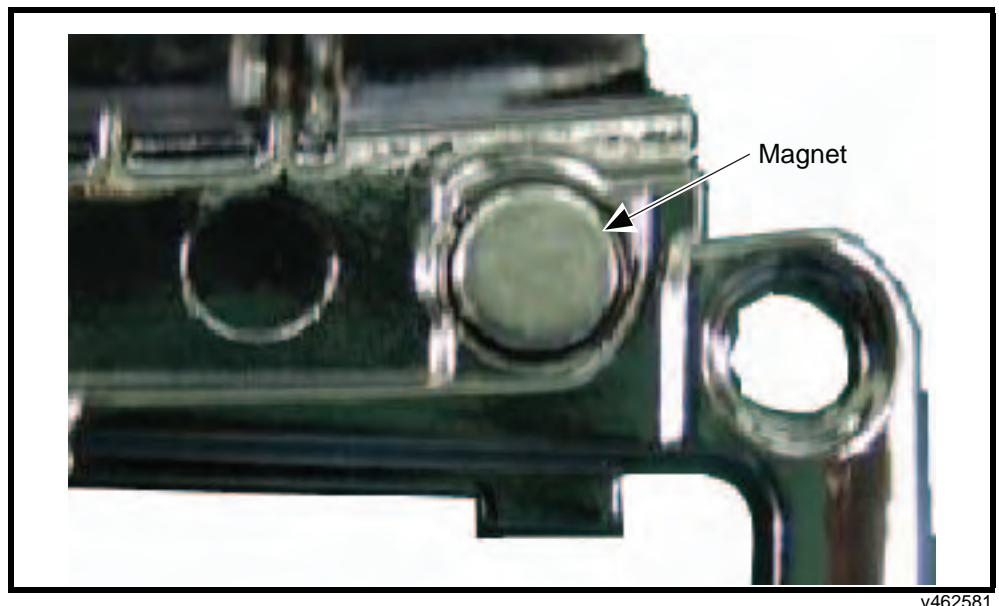
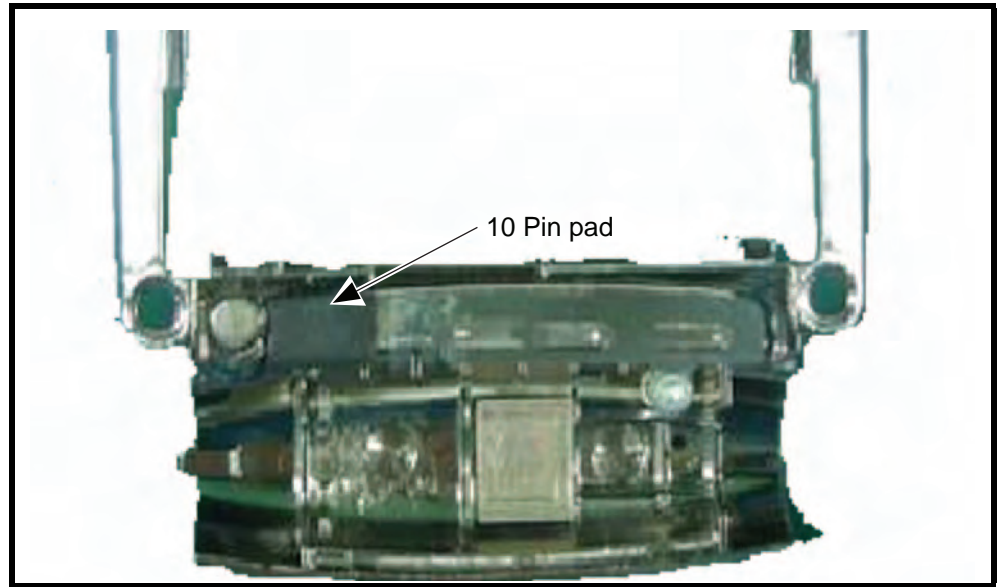

Figure 66. Installing the Magnet to the Flip Inner Assembly

3. Attach the 10 pin pad the to the back of the 10 pin connector.



v462582

Figure 67. installing 10 Pin Pad

Grounding Clip

1. Install the grounding clip and secure with T5 IP driver.

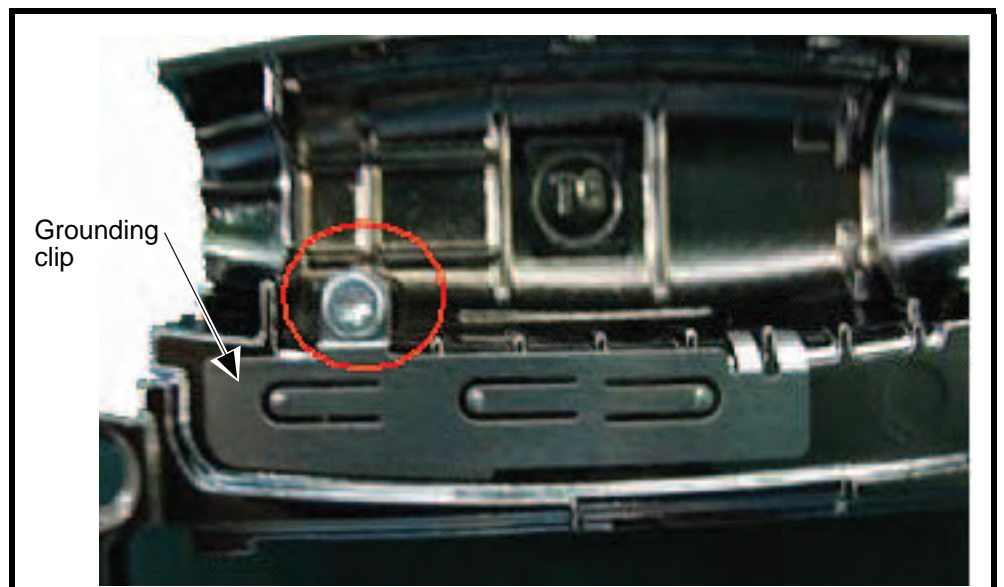

v462583

Figure 68. Installing Grounding Clip

Flip Inner

1. Assemble the camera upper grommet to the imager flex assembly.

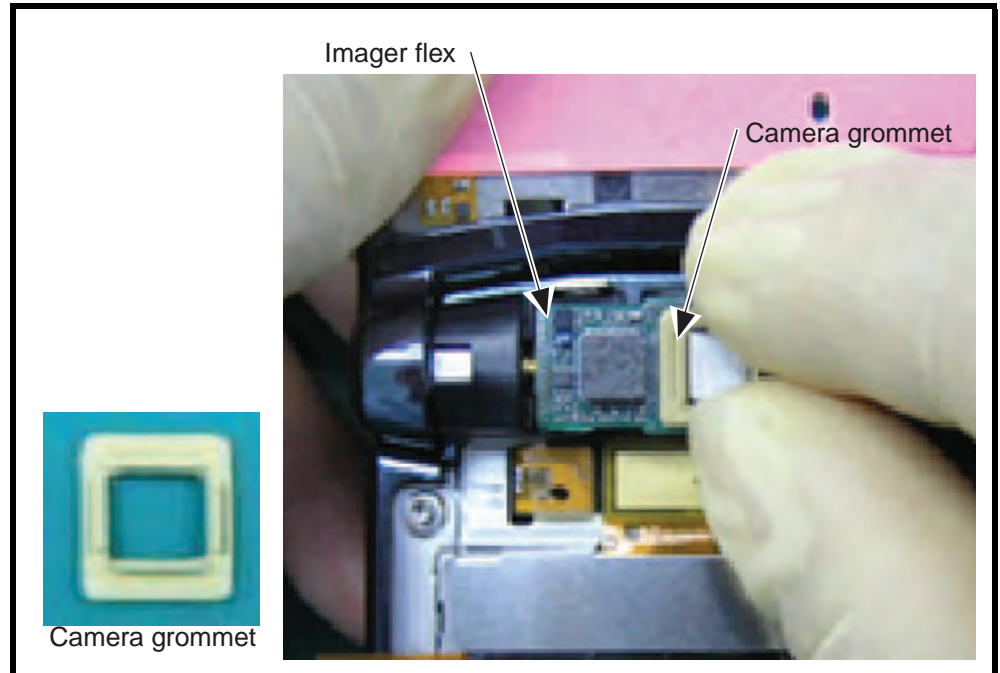

v463166

Figure 69. Installing Camera Upper Grommet

2. Assemble the flip inner assembly to the flip assembly.

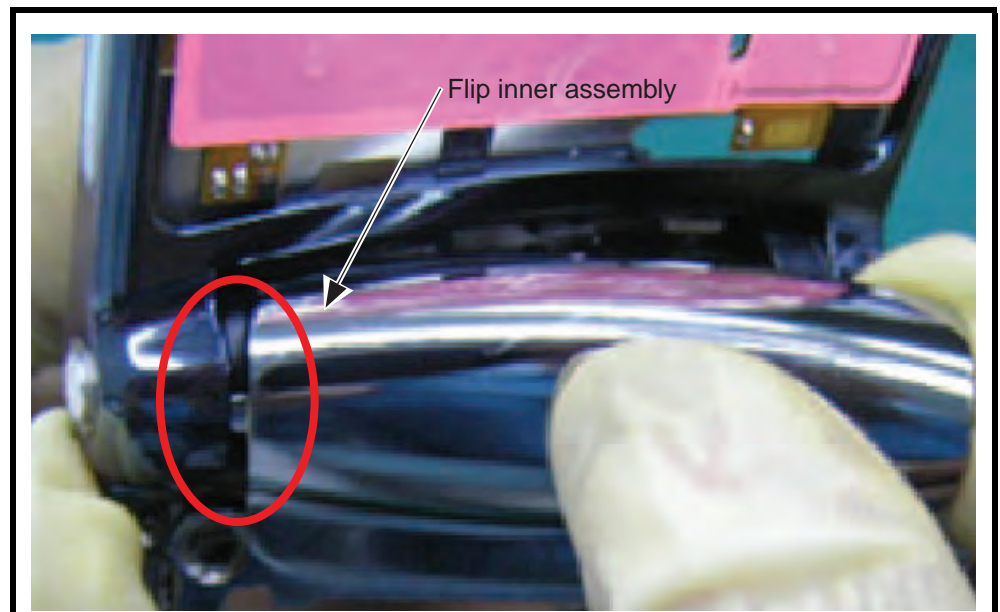

v463167

Figure 70. Installing the Flip Inner Assembly

Horseshoe and Main Lens

1. Peel the liner away from the earpiece horseshoe (see Figure 71).

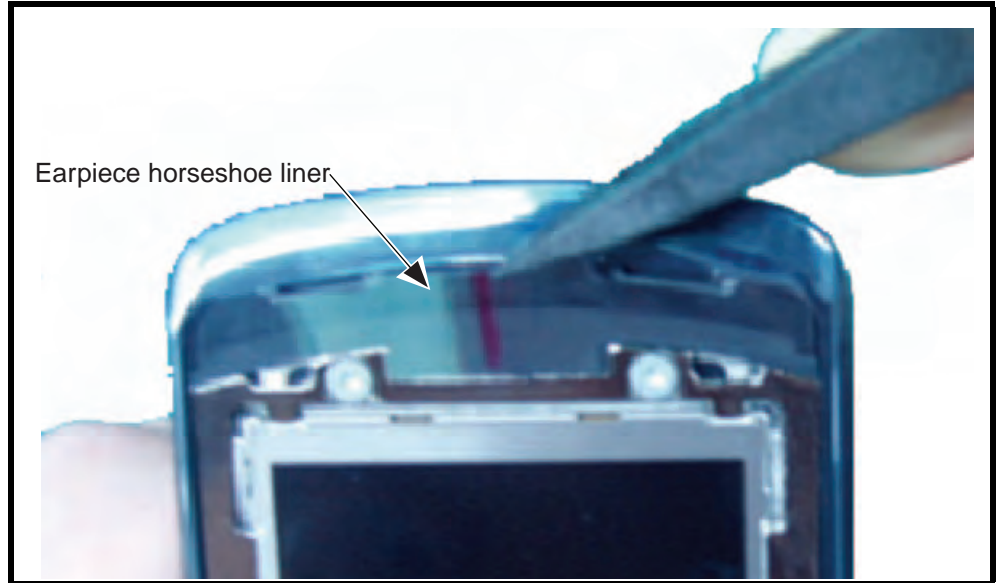

v463168

Figure 71. Removing the Earpiece Horseshoe Liner

2. Insert the two ends of the earpiece horseshoe into the flip assembly.

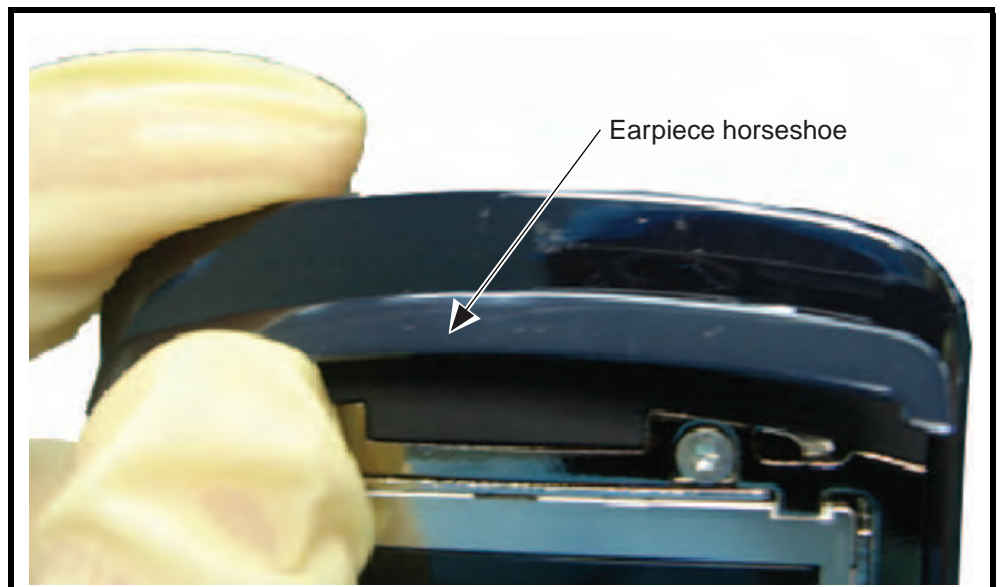

v463169

Figure 72. Installing the Earpiece Horseshoe

3. Peel away the liner from the LCD. Use an air gun to blow away any dust or foreign matter.



v463170

Figure 73. Removing the LCD Liner

4. Peel away the liner from the main lens. Use an air gun to blow away any dust or foreign matter.
5. Attach the main lens to the LCD. Align the main lens to the flip inner assembly.



v463171

Figure 74. Attaching the Main Lens

6. Place phone in the fixture.



v470100

Figure 75. Pressing the Main Lens

7. Close the fixture and hold for 13 seconds
8. Open the fixture and remove the phone.

Speaker Contacts

1. Use the plastic tweezers to install the speaker contacts in the front housing.

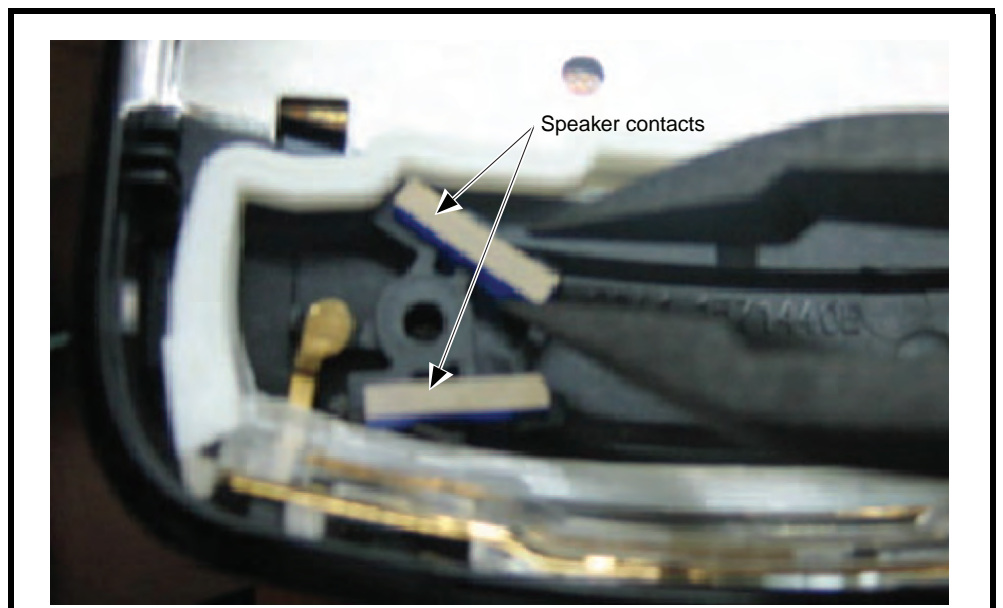

v462583

Figure 76. installing Speaker Contacts

2. Replace the transceiver board, antenna, rear housing, battery, and battery cover as described in the procedures.

Subscriber Identity Module (SIM) and Identification

SIM Card

A SIM is required to access the existing local GSM network, or remote networks when traveling (if a roaming agreement has been made with the provider).

The SIM contains:

- All the data necessary to access GSM services.
- The ability to store user information, such as phone numbers.
- All information required by the network provider to provide access to the network.

Personality Transfer

A personality transfer is required when a phone is express exchanged or when the main board is replaced. Personality transfers reproduce the customer's original personalized details, such as menu and stored memory, such as phone books, or even just program a unit with basic user information, such as language selection. V800 telephones use TrueSync® synchronization software to effect a personality transfer.

Identification

Each Motorola GSM device is labeled with a variety of identifying numbers. The following information describes the current identifying labels.

Mechanical Serial Number (MSN)

The Mechanical Serial Number (MSN) is an individual unit identity number and remains with the unit throughout the life of the unit.

The MSN can be used to log and track a unit on Motorola's Service Center Database. The MSN is divided into 4 sections, as shown in Figure 77.

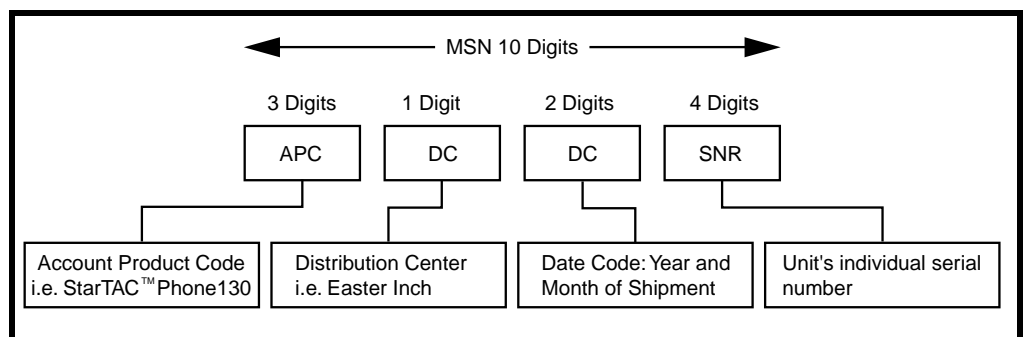

000807a

Figure 77. MSN Label breakdown

International Mobile Station Equipment Identity (IMEI)

The International Mobile station Equipment Identity (IMEI) number is an individual number unique to the PCB and is stored within the unit's memory.

The IMEI uniquely identifies an individual mobile station and thereby provides a means for controlling access to GSM networks based on mobile station types or individual units. The full IMEI structure is listed in Table 2.

Table 2. IMEI Number Breakdown

TAC	Serial Number	Check Digit
NNXXXXXX	ZZZZZZ	A

Where

TAC Type Allocation Code, formerly known as Type Approval Code

NN Reporting body identifier

XXXXXX Type Identifier

ZZZZZZ Individual unit serial number

A Phase 1 = 0.

Phase 2 = check digit defined as a function of all other IMEI digits

Other label number configurations present are:



- **TRANSCIVER NUMBER:** Identifies the product type. Normally the SWF number. (i.e. V100).
- **PACKAGE NUMBER:** Identifies the equipment type, mode, and language in which the product is shipped.

Troubleshooting

Manual Test Mode

Motorola V8 telephones are equipped with a manual test mode capability. This allows service personnel to verify functionality and perform fault isolation by entering keypad commands.

To enter the manual test command mode, a GSM / DCS test SIM must be used.

1. Press  to turn the phone OFF.
2. Remove the battery as described in the procedures.
3. Remove the customer's SIM card from the phone as described in the procedures.
4. Insert the test SIM into the SIM slot.
5. Replace the battery as described in the procedures.
6. Press  to turn the phone ON.

Manual Test Mode Commands

Table 3. Manual Test Commands

Key Sequence	Test Function/Name	Remarks
<Menu>048263*	Enter manual test mode	
"End" Key	Exit manual test mode	
54*	Suspend	Required for all Test Mode Operations
0*0*0	Select tone 0	
0*0*1	Select tone 1	
0*0*2	Select tone 2	
0*0*3	Select tone 3	
0*0*4	Select tone 4	
0*0*5	Select tone 5	
0*0*6	Select tone 6	
0*0*7	Select tone 7	
0*0*8	Select tone 8	
0*0*9	Select tone 9	
0*1*X	Disable tone X	
3*0*1	Enable vibrator	
3*0*0	Disable vibrator	
5*0*0	Set audio level 0	
5*0*1	Set audio level 1	
5*0*2	Set audio level 2	
5*0*3	Set audio level 3	
5*0*4	Set audio level 4	
5*0*5	Set audio level 5	
5*0*6	Set audio level 6	
5*0*7	Set audio level 7	

Table 3. Manual Test Commands (Continued)

Key Sequence	Test Function/Name	Remarks
5*0*8	Set audio level 8	
5*0*9	Set audio level 9	
5*0*10	Set audio level 10	
5*0*11	Set audio level 11	
5*0*12	Set audio level 12	
5*0*13	Set audio level 13	
5*0*14	Set audio level 14	
5*0*15	Set audio level 15	
6*2*2*0*0	Set Audio Path. Int Mic, IntSpk, RX unmute, TX unmute	
6*4*6*0*0	Set Audio Path. Boom Mic, Boom Spk, RX unmute, TX unmute	
10*0*3	Set band GSM 900	
10*0*4	Set band DCS 1800	
10*0*5		
10*0*6	Set dual band GSM 900 / 1800	
10*1*0	Read band	3= GSM 4= DCS 5= PCS 6 =GSM/DCS
18*0	Initialize non-volatile memory (Master Reset)	
18*1	Initialize non-volatile memory (Master Clear)	
55*2*001	Test Display. All pixels ON	
55*2*000	Test Display. All pixels OFF	
55*2*002	Test Display. Checkerboard pattern A	
55*2*003	Test Display. Checkerboard pattern B	
55*2*004	Test Display. Border pixels ON	
*#06#	IMEI Check	No Test Mode Required
Phone Set up --> Phone Status --> Other Information	Flex Version / Technology / S-W Version / Readiness Status	No Test Mode Required

Troubleshooting Chart

Table 4. Level 1 and 2 Troubleshooting Chart

SYMPTOM	PROBABLE CAUSE	VERIFICATION AND REMEDY
1. Telephone will not turn on or stay on.	a) Battery either discharged or defective.	Measure battery voltage across a 50 ohm (>1 Watt) load. If the battery voltage is <3.25 Vdc, recharge the battery using the appropriate battery charger. If the battery will not recharge, replace the battery. If battery is not at fault, proceed to b.
	b) Battery connectors open or misaligned.	Visually inspect the battery connectors on both the battery and the telephone. Realign and, if necessary, either replace the battery or refer to a Level 3 Service Center for the battery connector replacement. If battery connectors are not at fault, proceed to c.
	c) Transceiver board assembly defective.	Remove the transceiver board assembly. Substitute a known good assembly and temporarily reassemble the unit. Press and hold the PWR button; if unit turns on and stays on, disconnect the dc power source and reassemble the telephone with the new transceiver board assembly. Verify that the fault has been cleared.
2. Telephone exhibits poor reception or erratic operation, such as calls frequently dropping or weak or distorted audio.	a) Antenna assembly defective.	Check to make sure that the antenna pin is properly connected to the transceiver board assembly. If connected properly, substitute a known good antenna. If the fault is still present, proceed to b.
	b) Transceiver board assembly defective.	Replace the transceiver board assembly (refer to 1c). Verify that the fault has been cleared and reassemble the unit with the new transceiver board assembly.
3. Display is erratic, or provides partial or no display.	a) Transceiver board connections faulty.	Remove rear chassis assembly from unit, check general condition of flexible printed cable (flex). If the flex is good, check that the flex connector is fully pressed down. If not, check connector to transceiver board connections. If faulty connector, replace the transceiver board assembly. If connector is not at fault, proceed to b.
	b) Flip assembly defective.	Temporarily replace the flip assembly with a known good assembly. If fault has been cleared, reassemble with the new flip assembly. If fault not cleared, proceed to c.
	c) Transceiver board assembly defective.	Replace the transceiver board assembly (refer to 1c). Verify that the fault has been cleared and reassemble the unit with the new transceiver board assembly.
4. Incoming call alert transducer audio distorted or volume is too low.	Faulty transceiver board assembly.	Replace the transceiver board assembly (refer to 1c). Verify that the fault has been cleared and reassemble the unit with the new transceiver board assembly.
5. Telephone transmit audio is weak. (usually indicated by called parties complaining of difficulty in hearing voice).	a) Transceiver board assembly defective.	Replace the transceiver board assembly (refer to 1c). Verify that the fault has been cleared and reassemble the unit with the new transceiver board assembly.

Table 4. Level 1 and 2 Troubleshooting Chart (Continued)

SYMPTOM	PROBABLE CAUSE	VERIFICATION AND REMEDY
6. Receive audio from earpiece speaker is weak or distorted.	a) Connections to or from transceiver board assembly defective.	Gain access to the transceiver board assembly as described in the procedures. Check flex and the flex connector from the flip assembly to the transceiver board assembly. If flex is at fault, replace flip assembly. If flex connector is at fault, proceed to d. If connection is not at fault, proceed to b.
	b) Flip assembly defective.	Temporarily replace the flip assembly with a known good assembly. If fault has been cleared, reassemble with the new flip assembly. If fault not cleared, proceed to c.
	c) Antenna assembly defective.	Check to make sure the antenna is installed correctly. If the antenna is installed correctly, substitute a known good antenna assembly. If this does not clear the fault, reinstall the original antenna assembly and proceed to d.
	d) Transceiver board assembly defective.	Replace the transceiver board assembly (refer to 1c). Verify that the fault has been cleared and reassemble with the new transceiver board assembly.
7. Telephone will not recognize or accept SIM.	a) SIM defective.	Check the SIM contacts for dirt. Clean if necessary and check if fault has been cleared. If the contacts are clean, insert a known good SIM into the telephone. Power up the unit and confirm that the SIM has been accepted. If the fault no longer exists, replace the defective SIM. If the SIM is not at fault, proceed to b.
	b) Transceiver board assembly defective.	Replace the transceiver board assembly (refer to 1c). Verify that the fault has been cleared and reassemble the unit with the new transceiver board assembly.
8. Phone does not sense when flip is opened or closed (usually indicated by inability to answer incoming calls by opening the flip, or inability to make outgoing calls).	a) Flip assembly defective.	Temporarily replace the flip assembly with a known good assembly. If fault has been cleared, reassemble with the new flip assembly. If fault not cleared, proceed to b.
	b) Transceiver board assembly defective.	Replace the transceiver board assembly (refer to 1c). Verify that the fault has been cleared and reassemble the unit with the new transceiver board assembly.
9. Vibrator feature not functioning.	Transceiver board assembly defective.	Replace the transceiver board assembly (refer to 1c). Verify that the fault has been cleared and reassemble the unit with the new transceiver board assembly.
10. Internal Charger not working.	Faulty charger circuit on transceiver board assembly.	Test a selection of batteries in the rear pocket of the desktop charger. Check LED display for the charging indications. If these are charging properly, then the internal charger is at fault. Replace the transceiver board assembly (refer to 1c). Verify that the fault has been cleared and reassemble the unit with the new transceiver board assembly.
11. Real Time Clock resetting when standard battery is removed.	Lithium button cell in the display board may be depleted.	Refer service to a Level 3 service center for replacement.

Programming: Software Upgrade and Flexing

Contact your local technical support engineer for information about equipment and procedures for flashing and flexing.

Part Numbers

The following information is provided as a reference for the parts associated with V8 telephones.

Exploded View Diagram



v463245

Figure 78. Exploded View Diagram

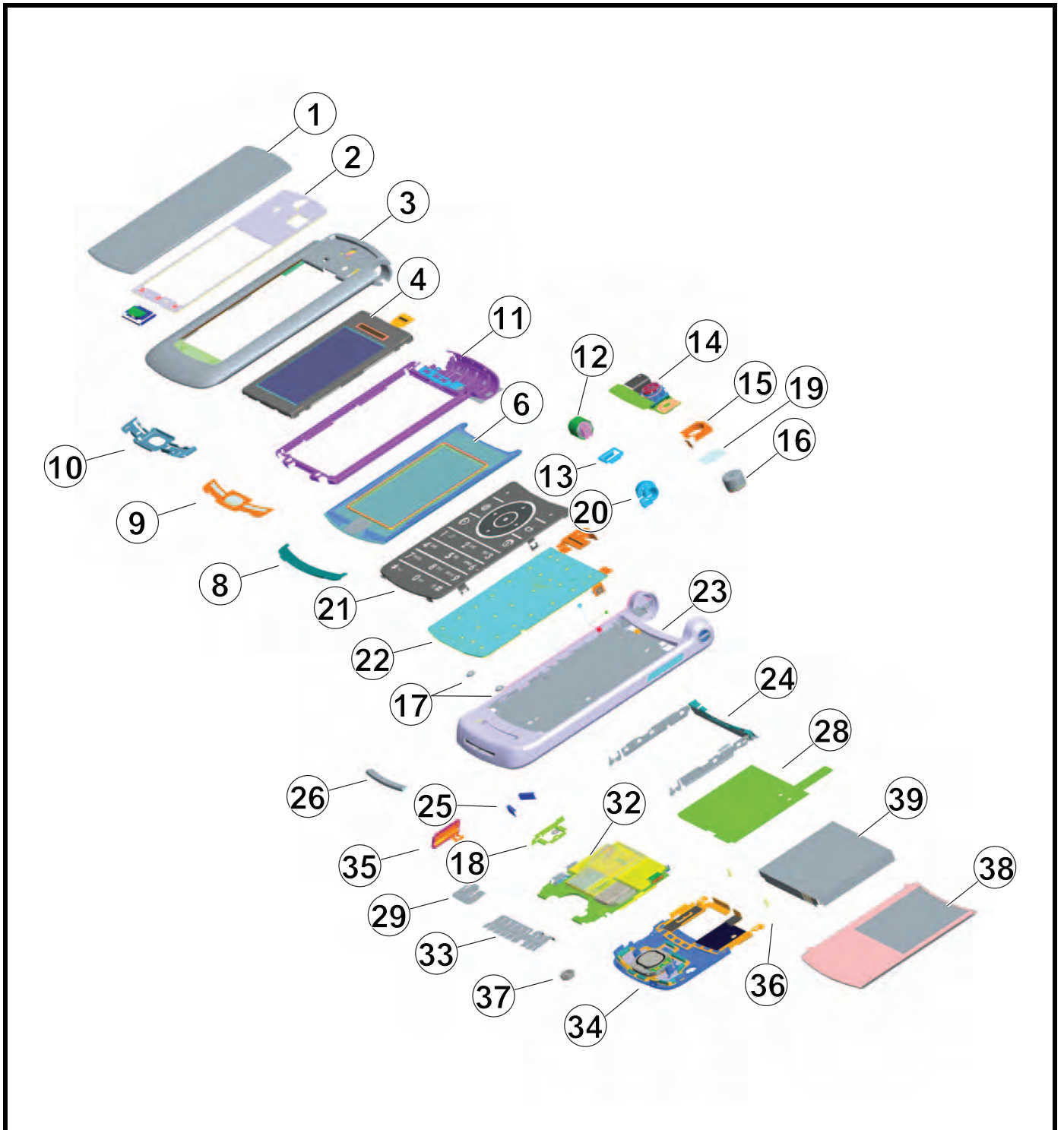

Figure 79. Exploded View Diagram

v470170

Exploded View Parts List

The following part numbers are provided only for reference. Please contact your local Motorola parts organization for current part number information.

Table 5. Parts List

Item Number	Motorola Part Number	Description
1	6171034G01	LENS ASSEMBLY,CLI,DECORATED,SPUN DPG,MOGEM
1	6171034G02	LENS ASSEMBLY,CLI,DECORATED,SPUN DN,MOGEM
1	6171034G06	LENS ASSEMBLY,CLI,DECORATED,SPUN, ESP
2	8471442E01	FLEX,PERSONALITY ASSY
3	1571355E02	HOUSING ASSEMBLY,OUTSIDE FLIP,DARK PEARL GREY,FINISHED
3	1571355E03	HOUSING ASSEMBLY,OUTSIDE FLIP,DARK NAVY,FINISHED
3	1571355E07	HOUSING ASSEMBLY,OUTSIDE FLIP,ESPRESSO LIGHT,FINISHED
4	7271203E02	DISPLAY,LCD,PANEL MOUNT,2.775V,RECTANGULAR,33.84X45.12,262K,240X320,ASSEMBLY
5	1171614G01	TAPE,FLEX,KAPTON KFLEX FLIP DETECT SWITCH
5	1171614G02	TAPE,FLEX,KAPTON KFLEX LIGHT SENSOR
6	6171435E02	LENS ASSEMBLY,DISPLAY,MAIN
6	6171435E03	LENS ASSEMBLY,DISPLAY,MAIN, DARK NAVY
6	6171435E04	LENS ASSEMBLY,DISPLAY,MAIN, ESPRESSO
7	7571379F02	PAD,FOAM,70 PIN TAIL, KEYPAD FLEX
8	1371840E03	GRILL,EARPIECE,HORSESHOE DECORATED,DARK NAVY,DARKENED
8	1371840E08	ESCUTCHEON,EARPIECE,PLASTIC - HORSESHOE,DARK PEARL GREY,DARKENED
8	1371840E09	ESCUTCHEON,EARPIECE,PLASTIC - HORSESHOE,ESPRESSO,DARKENED
9	3271428E01	GASKET,PLASTIC-POLYESTER,FLIP INNER, EAR PIECE PORT
9	3271428E02	GASKET,PLASTIC-POLYESTER,FLIP INNER,EARPIECE PORT,DARK PEARL BLUE
10	4371839E01	INSERT,PLASTIC,NOSE
11	0171609E01	ASSEMBLY,FLIP,INNER ASSEMBLY
12	5571666E01	HINGE,FLIP
13	0571584E01	GROMMET,CUSTOM,CONDUCTIVE ELASTOMER,UPPER CAMERA
14	0171004R01	CAMERA,FLEX PCB IMAGER ASSEMBLY
15	0571351E01	GROMMET,THERMOPLASTIC RUBBER,CAMERA/ VIB BASE
16	5971886E01	ALERT DEVICE,VIBRATOR,.75V,LIN 8MM DIAMETER X 5MM
17	0371359E01	SCREW,MACHINE,M1.4X.3,1.3MM,STAR,PAN,STEEL,ZINC PLATED
18	0571232G01	GROMMET,THERMOPLASTIC RUBBER,SANTO,COMPONENT COVER
19	0771141F01	BRACKET ASSEMBLY,MOUNTING,SINGAPORE VIBRATOR SPACER
20	4371600E01	BUSHING,ZINC,HOUSING,COLLAR FLIP INNER BARREL
21	3871371E07	KEYPAD,ASSY, ENGLISH, ESPRESSO
21	3871371E10	KEYPAD,ASSY, GSM ENGLISH, DARK PEARL GRAY
21	3871371E11	KEYPAD,ASSY, GSM ENGLISH, DARK NAVY
21	3871371E12	KEYPAD,ASSY, GSM STROKE W/CMCC MUSIC KEY, ESPRESSO
21	3871371E13	KEYPAD,ASSY, GSM STROKEW/CMCC MUSIC KEY, DARK PEARL GRAY
21	3871371E14	KEYPAD,ASSY, GSM BOPOMOFO, ESPRESSO
21	3871371E15	KEYPAD,ASSY, GSM BOPOMOFO, DARK PEARL GRAY
21	3871371E16	KEYPAD,ASSY, GSM THAI, ESPRESSO
21	3871371E17	KEYPAD,ASSY, GSM THAI, DARK PEARL GRAY

Table 5. Parts List (Continued)

Item Number	Motorola Part Number	Description
21	3871371E18	KEYPAD,ASSY, GSM HEBREW, ESPRESSO
21	3871371E19	KEYPAD,ASSY, GSM HEBREW, DARK PEARL GRAY
21	3871371E20	KEYPAD,ASSY, GSM RUSSIAN, ESPRESSO
21	3871371E21	KEYPAD,ASSY, GSM RUSSIAN, DARK PEARL GRAY
21	3871371E22	KEYPAD,ASSY, GSM ARABIC, ESPRESSO
21	3871371E23	KEYPAD,ASSY, GSM ARABIC, DARK PEARL GRAY
21	3871371E25	KEYPAD,ASSEMBLY, GSM ENGLISH WITH BROWSER, DARK NAVY
21	3871371E26	KEYPAD,ASSEMBLY, GSM STROKE W/GENERIC MUSIC ESPRESSO
21	3871371E27	KEYPAD,ASSEMBLY, GSM STROKE W/GENERIC MUSIC DARK PEARL GRAY
21	3871371E32	KEYPAD,ASSEMBLY,GSM STROKE W/CMCC BROWSER KEY,ESPRESSO
21	3871371E33	KEYPAD,ASSEMBLY,GSM STROKE W/CMCC BROWSER KEY,DARK PEARL GREY
22	0171127R01	FLEX,KEYPAD,ASSEMBLY
23	1571441E08	HOUSING ASSEMBLY,FRONT, DPG
23	1571441E09	HOUSING ASSEMBLY,FRONT, DN
23	1571441E10	HOUSING ASSEMBLY,FRONT, ESPRESSO LITE
24	2771230F03	CHASSIS ASSEMBLY,BATTERY,RETENTION
25	3987404Y04	CONNECTOR ELASTOMERIC,BOARD TO BOARD,1CONT,GOLD,CONTACT SPEAKER
26	7571599E02	BUMPER,RUBBER,FLIP,STOP,DARK PEARL GREY LIGHT
26	7571599E03	BUMPER,RUBBER,FLIP,STOP,DARK NAVY LIGHT
26	7571599E04	BUMPER,RUBBER,FLIP,STOP,ESPRESSO LIGHT
27	7571379F01	PAD,FOAM,SIDE SWITCH, KEYPAD FLEX
28	1471201F02	INSULATOR,TAPE,PLASTIC-POLYESTER,BATTERY WITH PULL TAB
28	1471201F09	INSULATOR,TAPE,PLASTIC-POLYESTER,BATTERY, PULLTAB, CIRCULAR, SIM CARD PREPRINT
29	3971796G01	CONTACT,CLIP,3CONT,GROUNDING BOOTSTRAP, REAR
30	3271459E01	GASKET,POLYURETHANE FOAM,MICROPHONE
30	3271459E02	GASKET,POLYURETHANE FOAM MICROPHONE
31	5485042F02	LABEL,INFORMATION,WATER INDICATOR
32	SLG5155AA-	ASSEMBLY,PRINTED CIRCUIT BOARD,TRANSCEIVER,GSM BOARD KIT
32	SLG5327AA-	ASSEMBLY,PRINTED CIRCUIT BOARD,TRANSCEIVER,V9,T-LIDO/MOTORIZR MAIN KIT
33	3971888E02	CONTACT,CLIP,XCVR GROUND LIDO
34	1571419G02	HOUSING ASSEMBLY,REAR,DARK PEARL GREY
34	1571419G03	HOUSING ASSEMBLY,REAR,DARK NAVY
34	1571419G04	HOUSING ASSEMBLY,REAR,ESPRESSO
34a	1571026G01	HOUSING,REAR,PLASTIC - POLYCARBONATE,DARK PEARL GREY,IM FINISHED
34a	1571026G02	HOUSING,REAR,PLASTIC - POLYCARBONATE,DARK NAVY,IM FINISHED
34a	1571026G03	HOUSING,REAR,PLASTIC - POLYCARBONATE,ESPRESSO,IM FINISHED
34b	3571374E01	SCREEN,ACOUSTIC,RH
34b	3571374E02	SCREEN,ACOUSTIC,RH,DARK BLUE
34b	3571374E04	SCREEN,ACOUSTIC,RH,CALI DREAM
34c	0571457E01	GROMMET,THERMOPLASTIC RUBBER,ACOUSTIC
34d	5071508D03	LOUDSPEAKER,DYNAMIC,600-7000,8OHM,.5W,CONTACT,3X14X20
34e	7571680F01	PAD, PORON 70 PIN K-FLEX RETENTION

Table 5. Parts List (Continued)

Item Number	Motorola Part Number	Description
34f	1471250G01	INSULATOR,TAPE,POLYESTER,REAR HSG
34g	7571653G01	PAD,PORON VBUC
35	1571369E02	COVER,USB,PLASTIC-POLYCARBONATE,DARK PEARL GREY,MICRO
35	1571369E03	COVER,USB,PLASTIC-POLYCARBONATE,NAV,MICRO
35	1571369E04	COVER,USB,PLASTIC-POLYCARBONATE,ESP,MICRO
36	0371373E01	SCREW,MACHINE,M1.6X.64,3.7MM,STAR,BUTTON,STEEL
37	0571458E02	GROMMET,THERMOPLASTIC RUBBER,RF,DPG
37	0571458E03	GROMMET,THERMOPLASTIC RUBBER,RF,DARK PEARL GREY
37	0571458E04	GROMMET,THERMOPLASTIC RUBBER,TPR,RF,ESP
38	SHN0778A	ASSEMBLY,HOUSING,BATTERY DOOR,CMCC,ESPRESSO
38	SHN0782A	ASSEMBLY,HOUSING,BATTERY DOOR,DARK PEARL GREY
38	SHN0786A	ASSEMBLY,HOUSING,BATTERY DOOR,ESPRESSO
38	SHN0792A	ASSEMBLY,HOUSING,BATTERY DOOR,DARK NAVY
38	SHN0804A	ASSEMBLY,HOUSING,BATTERY DOOR,DARK NAVY,T-MOBILE US
38	SHN0888A	ASSEMBLY,HOUSING,BATTERY DOOR,DARK PEARL GREY,CMCC
38	SHN1012A	ASSEMBLY,COVER,BATTERY DOOR,V8,DARK PEARL GREY,BX40 CMCC XINJI
38	SHN1013A	ASSEMBLY,COVER,BATTERY DOOR,V8,ESPRESSO,BX40 CMCC XINJI
39	SNN5805A	ASSEMBLY,BATTERY,LITHIUM ION,BX40,740MAH
NA	5471536C01	LABEL,ADHESIVE,WATER DETECT, 3MM X .26

The "Replacement Parts Service Division (RPSD)" section on page 7 provides information about ordering replacement parts.



There is a danger of explosion if the Lithium Ion battery pack is replaced incorrectly. Replace only with the same type of battery or equivalent as recommended by the battery manufacturer. Dispose of used batteries according to the manufacturer's instructions.

Accessories

Table 6. Accessories

Description	Kit Number
Automotive & Navigation	
Bluetooth Car Kit - HF850	98675H
T305 Portable Bluetooth Hands-Free Speaker, Bluetooth Car Kit, Mid Tier	SYN1716
BT Pro-Install Car Kit IHF1000r	98676K
Bluetooth Automotive Music & Handsfree System T605	CFLN6400AA
Data & Business Communications	
Bluetooth Class 1 USB Adapter PC850	SYN1244
Data Cable Mini USB/USB/Serial	SKN6371
Digital Accessories	
Motorola Phone Tools Phase 4	SVN5539
MobileVoice (Wireless BT Headsets)	
Mono Bluetooth Headset	SYN1971
Bluetooth Headset - MiniBlue H9 (Includes headset, charger base, and extra ear tips)	SJ0095A
Bluetooth Headset -Black Licorice-H800	SYN1626
Bluetooth Headset-Fire Red-H800	SYN1640
Bluetooth Headset-Silver Moss-H800	SYN1641
Bluetooth Headset-Silver Quartz-H800	SYN1642
Bluetooth Headset RAZR H3 Black	SYN1437
Bluetooth Headset RAZR H3 Silver	SYN1438
Bluetooth Headset - Plum - H700	SYN1818
Bluetooth Headset - Dark Pearl Blue - H800	SYN1639
Bluetooth Headset - Fire Red - H700	SYN1820
Bluetooth Headset H555 Black/Black (RAZR)	SYN1854
Bluetooth Headset H670 Black Slate (Canary)	SYN1853
Bluetooth Headset - Pale Lilac - H350	SYN1948
Bluetooth Headset Blue H700 (Verizon only in North America)	SYN1618
Bluetooth Headset H505 EZ Pair - Black Gloss	SYN1949
Bluetooth Headset H505 EZ Pair - Pink	SYN1965
Bluetooth Headset H550 Silver (SLVR)	SYN1822
Bluetooth Headset H555 Silver/Black (RAZR)	SYN1821
Bluetooth Headset H670 Cosmic Blue (Canary)	SYN1855
Bluetooth Headset H670 Silver Quartz (Canary)	SYN1852
Bluetooth Headset Black H700 (not available in North America)	SYN1509
Bluetooth Headset - H700 (silver)	SYN1311
Bluetooth Headset - H605	SYN1303
Bluetooth Headset - HS850 (Refresh - Black)	SYN1107
Bluetooth Headset - HS850 (Refresh - Blue)	SYN1226
Bluetooth Headset (Pearl Dark Gray) - H300	SYN1297
Bluetooth Headset (Pink) - H300	SYN1417
Bluetooth Headset (Pure White) - H300	SYN1416
Bluetooth Mono Headset, Nickel- H500	SYN1290
Bluetooth Headset H3 Cherry Red	SYN1736

Table 6. Accessories (Continued)

Description	Kit Number
Bluetooth Headset Dark Pearl Grey H3	SYN1507
Bluetooth Headset H350 Dark Pearl Grey	SYN1763
Bluetooth Headset H350 Sapphire Blue	SYN1738
Bluetooth Headset H350 Silver Quartz	SYN1765
Bluetooth Headset H350 Silver Sail	SYN1764
Bluetooth Headset H350 Black	SYN1439
Bluetooth Headset Soft touch Black H500	SYN1374
Bluetooth Headset H500 Fire Red	SYN1667
Bluetooth Headset H500 Pink	SYN1436
Oakley RAZRWIRE (Mercury: NA) - H7	98679H
Oakley RAZRWIRE (Pewter/Black: NA) - H7	98677H
Oakley RAZRWIRE (Platinum/Rootbeer: NA) - H7	98678H
Music & Entertainment	
Headset - Neckloop	SYN7875
Headset Mono One Touch w/ Send-End (EMU)	SYN0896
JBL On Tour Mobile portable speaker US Kit	OnTourMBBLK
JBL On Tour Mobile speaker PRC kit	CH1414A
Adapter EMU to 2.5mm stereo	SYN1505
Adapter EMU to 3.5 mm	SYN1504
Stereo Headset - EMU	SYN1301
Personalization	
Cleaner - Screen - V3	SYN1223
Lanyard - Silver	AAYN4402
Wristyard - Silver	AAYN4403
Belt Clip - All Plastic - Cost Reduced (Black)	SYN9853
Power	
Charger Adapter EMU/CE (Y-cable)	SKN6185
Charger Adapter EMU/EMU (Y-cable)	SKN6222
Battery-Only-Charger - Razor V3, South Asia plug	CHPN4613
Battery-Only-Charger V3 (BR) batty US plug	CHPN4613
Battery BR91 (RZ9) Li-Ion 1480 mAh - VZW	SNN5788
Dual Charging Adapter - EMU/EMU/MU YCABLE	SKN6243
Battery BZ60 Li-Ion 940mAh	SNN5789
P320 desktop BOC (battery-only-charge), platform, EMU	SPN5394
P320 desktop BOC, platform, EMU, Chinese label	SPN5395
P790 Portable Charger	SPN5353
Standard Car Charger EMU - P310	SYN1630
Travel Charger EMU Mid-Rate Switcher - Argentina	SPN5192
Travel Charger EMU Mid-Rate Switcher - BRAZIL	SPN5187
Travel Charger EMU Mid-Rate Switcher - EURO	SPN5189
Travel Charger EMU Mid-Rate Switcher - MEXICO	SPN5186
Travel Charger EMU Mid-Rate Switcher - PRC	SPN5188
Travel Charger EMU Mid-Rate Switcher - US ENG	SPN5185
Travel Charger EMU Rapid Switcher - Argentina	SPN5197
Travel Charger EMU Rapid Switcher - BRAZIL	SPN5196

Table 6. Accessories (Continued)

Description	Kit Number
Travel Charger EMU Rapid Switcher - MEXICO	SPN5200
Travel Charger EMU Rapid Switcher - PRC	SPN5198
Travel Charger EMU Rapid Switcher - US	SPN5202
Vehicle Power Adapter EMU - VC700	SYN0847

A

active line indicator 18
airplane mode 17
alert settings 19
alert style profiles 18
antenna, removing and replacing 37

B

battery
 function 19
 gauge 19
 removing 22
battery housing
 removing 22
battery indicator 18
Bluetooth indicator 18

C

call forward indicator 18
caller ID 14
Canadian Interference-Causing Equipment regulations 5
changes
 product 5
commands, manual test mode 79
conventions 7
copyrights
 computer software 6

D

disassembly 22

E

EDGE indicator 17
exploded view diagram 84
exploded view parts list 86

F

FCC rules 5
features
 caller ID 14
 SIM Toolkit 13
 text entry 14
 voice recognition 13
 Wireless Access Protocol (WAP) 13
flip assembly, removing and replacing 46

G

GPRS indicator 17

I

identification 77
 international mobile station equipment identity 78
 mechanical serial number 77
 product 5
IM indicators 18
IMEI 78
in-call indicator 18
Introduction 5

K

keypad, removing and replacing 39

L

location indicator 18
Low Battery message 18

M

manual test mode 79
menu
 structure diagram 19
message indicator 18
MSN 77

N

names
 product 5

O

operation
 controls, indicators, and I/O 15
operation, general 15
overview, product 11

P

part numbers
 accessories 89
parts 83
 exploded view diagram 84
 exploded view parts list 86
product
 changes 5
 identification 5
 names 5
product overview

- features 11
- profile indicator 18
- profiles 18

R

- rear housing
 - removing 25
- regulatory agency compliance 5
- removing
 - antenna 37
 - battery 19, 22
 - battery housing 22
 - flip assembly 46
 - keypad 39
 - rear housing 25
 - SIM 24
 - transceiver board assembly 34
- replacement parts
 - contact information 7
- replacing
 - antenna 37
 - battery 22
 - flip assembly 46
 - keypad 39
 - rear housing 25
 - SIM 24
 - transceiver board assembly 34

S

- serial number
 - mechanical 77
- service manual
 - about 6
 - revisions 7
 - scope 6
- service policy 7
 - customer support 7
 - out of box failure 7
 - product support 7
- service procedure
 - ordering replacement parts 7
- shut down
 - upon battery removal 19
- signal strength indicator 17
- SIM Application Toolkit 13
- SIM card 77
 - personality transfer 77
 - replacing 24
- SIM, removing and replacing 24
- specifications 9

- support
 - customer 7
 - product 7

T

- text entry 14
- tools and test equipment 21
- transceiver board assembly, removing and replacing 34
- troubleshooting 79
 - manual test mode 79
 - manual test mode commands 79

U

- user interface diagrams 19

V

- voice recognition 13

W

- warranty service 7
- wireless access protocol (WAP) 13



MOTOROLA