



MOTOROLA

Consumer Solutions & Support
US Competency Center
600 North US Highway 45
Libertyville, Illinois 60048
Website: gs.mot.com

FIELD SERVICE BULLETIN

FSB Number: LVCCFSB2006-36
Authors: Darwin Garcia
Date: February 14, 2006
Total No. of Pages: 2
Subject: **V3i Keypad Intermittent – FM Contamination**
Model Affected: **V3i**
Level of Repair: 2

Problem

Service has been made aware of a V3i Keypad Intermittent issue causing “Main Keypad - No function/ hangs” complaints.
Initial analysis found foreign material under the dome on K-flex pads impeding contact.

FM Contamination

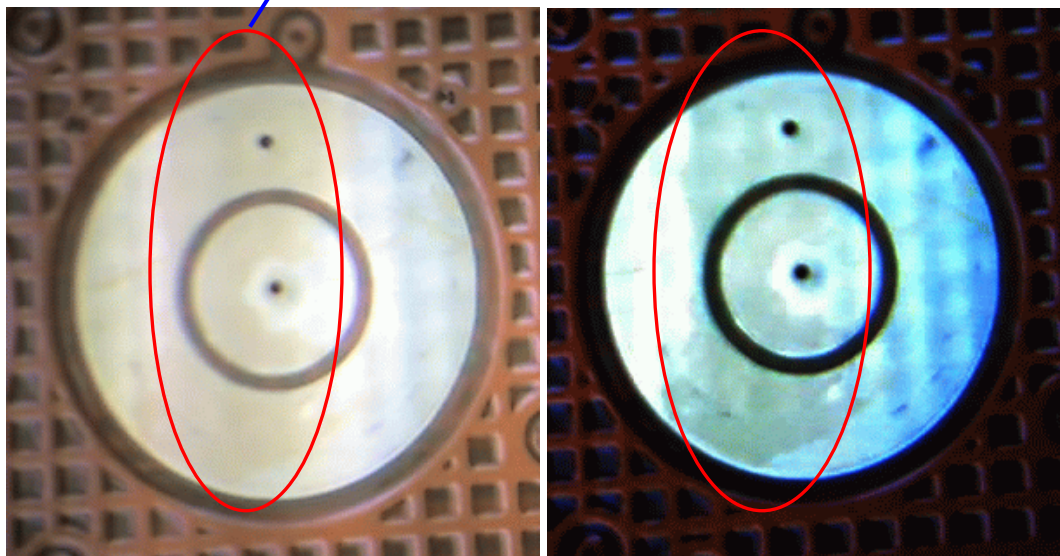

Solution

This FSB version does not contain a solution, since it has not been identified.
As part of the FSB release process improvement initiative, V3i FSB’s will be initially released with ONLY the initial analysis and repair action identified.
A new revision will be released once in-depth analysis and solution information (Corrective Action) are available.



MOTOROLA

**Consumer Solutions & Support
US Competency Center
600 North US Highway 45
Libertyville, Illinois 60048
Website: gs.mot.com**

Field Service Action

Customer Returns:

When servicing any V3i customer phones with described complaint, replace the keyboard flex assembly module (Part Number 22= 8471183B02).

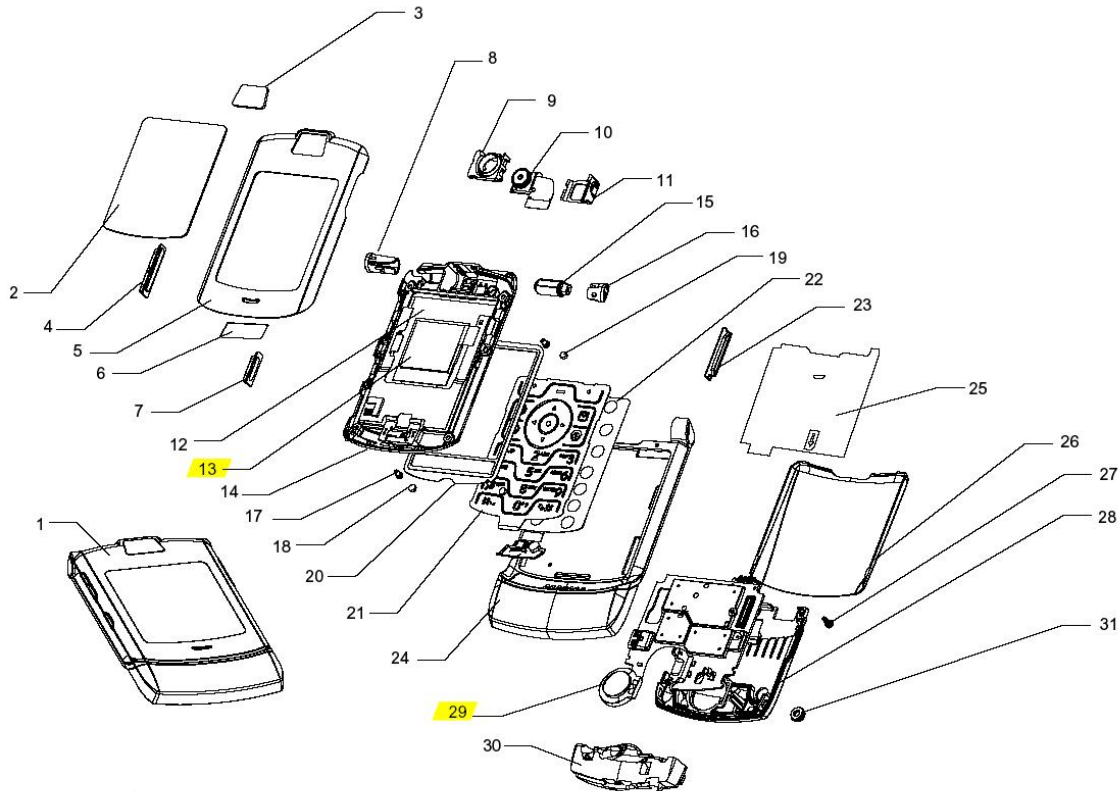

Call Center Action:

Call center should advise callers to send phone for repair.

Service Inventory

N/A

Global Codes

M Claims:

Customer Complaint Codes:

Problem Found Code:

Repair Code: RTW02 (Replace Level 2 part - CSB/FSB)