

[PRINT](#)



MOTOROLA UK
 REDWOOD
 CROCKFORD LANE
 CHINEHAM BUSINESS P/
 CHINEHAM
 BASINGSTOKE
 UNITED KINGDOM RG24

CSB-1105-3
 Country : UK
 Date : 11/1/2006
 APC : ALL
 Repair Level : 3

Title RAZR V3i - GSM - GSM V3i - Alert - No Ringtone
 Model Effected All
PROBLEM

Service is aware that some GSM V3i phones from Brasil have been returned with customer complaints related to Alert – No Ring. The failure mode analysis revealed that the inductor L1422, Part Number 2471992B42 is being damaged in the manufacturing assembly process, thus causing customer to notice a difficult with ringtones - no alert audio. See pictures below :

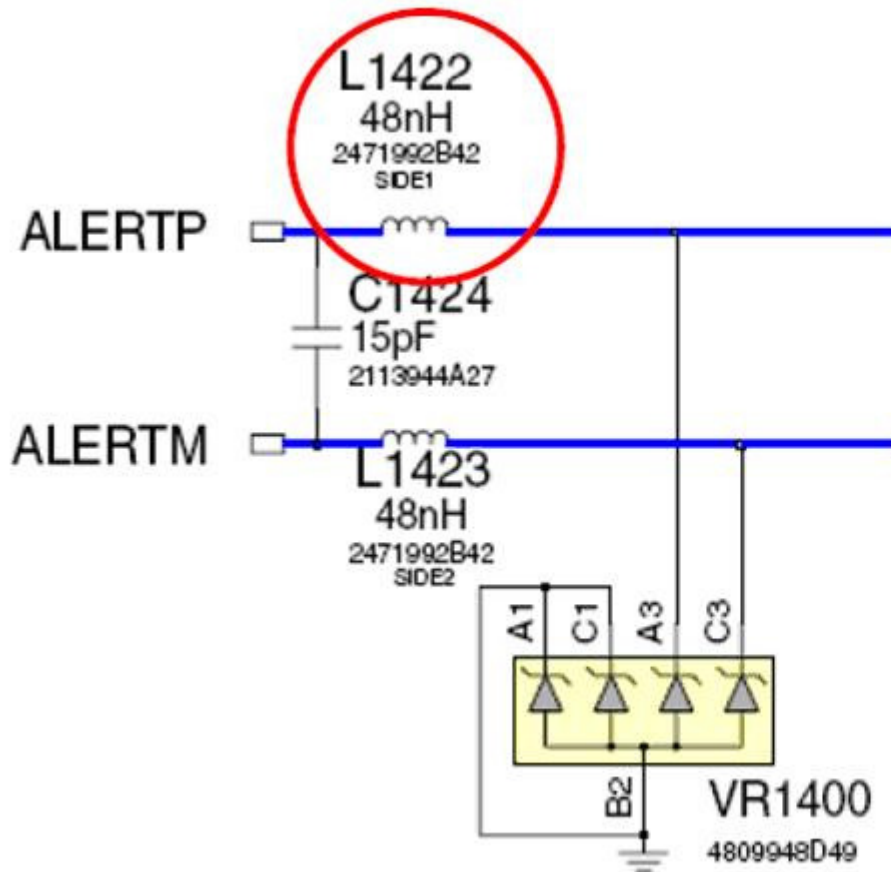

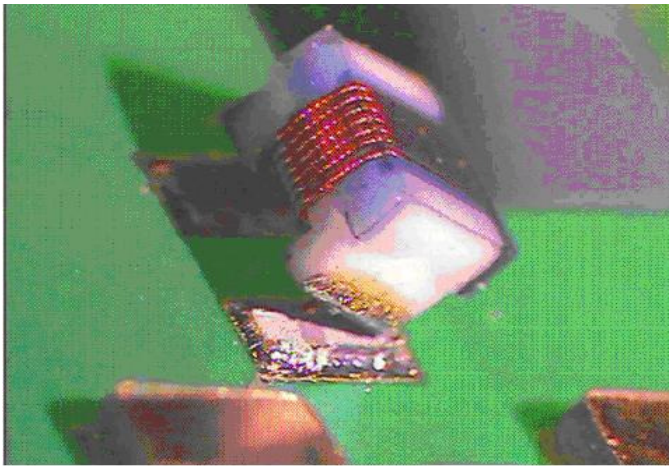

SOLUTION

Field solution is to replace the L1422 inductor damaged, missing or misplaced.

The long term solution is to introduce new work instructions with visual shop-aids highlighting the correct and usual step-by-step procedure for antenna housing assemble and disassemble in manufacturing process; Reinforce skill training in the assembly and rework stations with new procedure; Introduce new interactive alert test in CIT test station to prevent operator from skipping unit I test conclusion results, avoiding false PASS result. Implementation date to manufacturing is November-06, 2006.

FIELD SERVICE ACTION

Customer Returns:

When servicing affected models of GSM V3i customer returns with customer complaint relating to "Audio – No Ringtone" then:

1. Verify customer complaint per normal procedure.
2. If customer complaint is confirmed, verify if the inductor L1422, Part Number 2471992B42 is misplaced, broken or missing, according to pictures above.
3. If L1422 is misplaced, broken or missing, proceed the replacement of L1422 as per service procedures.

4. If not confirmed L1422 misplaced, broken or missing, then proceed with normal troubleshooting techniques per customer complaint.

Service Inventory:

No actions available.

CALL CENTER ACTION

When responding to customer inquiries on GSM V3i with complaints related to Alert – No Ringtone, please direct the customers to their phones serviced as per this FSB.

SERVICE ENTRY CODE**Global Service Codes**

Complaint Code: ALT01 - Alert - Ring tone , no

Problem Found Code: ALT01 - Alert - Ring tone , no

Reference Designator:L - Coil, Choke, Inductor

Repair Code: REP02 - Replace Electrical Part - Damaged
REP03 - Replace Electrical Part - Missing

If applicable, note this bulletin number on warranty claim forms and make necessary changes to service manuals.2006-454
© Copyright 2006 Motorola Inc. All Rights Reserved.
