



MOTOROLA UK
REDWOOD
CROCKFORD LANE
CHINEHAM BUSINESS
CHINEHAM
BASINGSTOKE
UNITED KINGDOM R

CSB-1224-2
Country : UK
Date : 2/18/2007
APC : ALL
Repair Level : 2

Title
Model Effected

RAZR V3i - GSM - Static Audio – P-Flex shorted to display bezel
V3i & V3t

PROBLEM

Service has been made aware of a V3i/V3t Siliqua P-Flex Shorting issue in where only static audio can be heard from the ear during power on, key press, and in a call. The P-Flex contains SPKRP audio traces for the earpiece speaker. This flex is being shorted and grounded by a burr on the display bezel. Also refer to BJCCFSB2006-76.

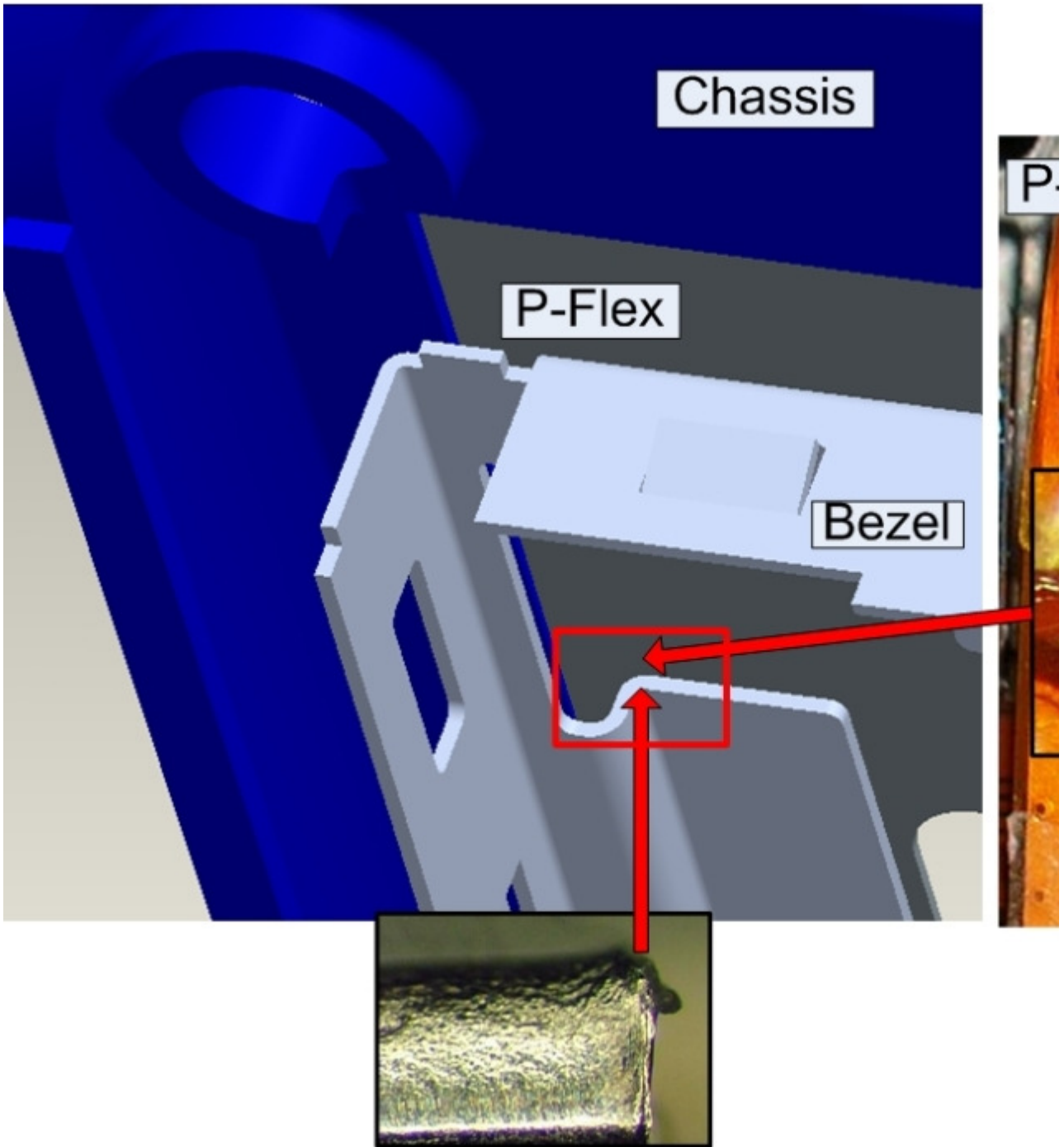

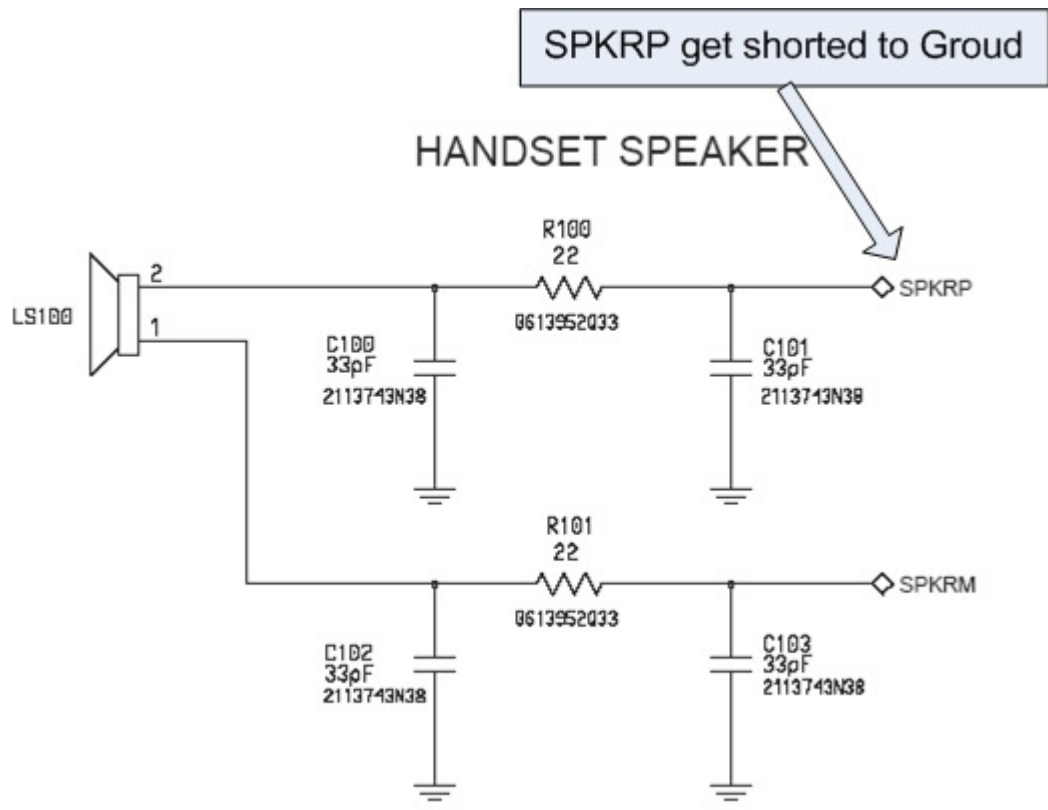

There are two main contributing factors, the placement of the kapton tape and the burr on the display bezel. First the kapton intended to protect the P-Flex from the display bezel edge which has burr was not being placed correctly during the assembly thus allowing the bezel burr to come into contact with the flex. Second the burr created during the stamping of the display bezel was found to be sharper than expected, which allows the burr to become more dangerous to the P-Flex.

Placement of the Kapton Tape

Incorrect -
Placement of tape
on the P-Flex

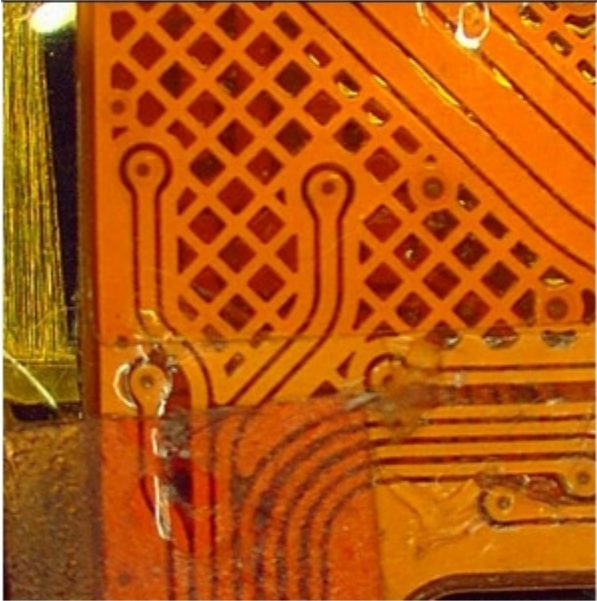

APPLY KAPTON TAPE TO THESE 3 EDGES OF THE DISPLAY BEZEL.

XXX

NUMBER OF FLIP ASSEMBLY

CODE

PART	SUPPLIER	CODE
Pflex (PF)	M-FLEX	PM
	N-WING	PN
Kflex (KF)	M-FLEX	KM
	N-WING	KN
SANYO(WINTEK)		cm

Correct of the b

SOLUTION

Manufacturing has corrected the placement process of the kapton tape on 2/9/2007. The display supplier is improving the manufacturing process to reduce burrs of the bezel.

FIELD SERVICE ACTION

When servicing any V3i/V3t customer phones with described issue, the P-Flex must be replaced and kapton tape added. Pe Flex Assy # 8489906Y01 Kapton Tape # 1171760D01. All repairs in where the P-Flex is replaced, the kapton tape must be placed on the display bezel with the bend corner and burrs completely covered (See Placement Instructions).

Placement instructions for the Kapton Tape c

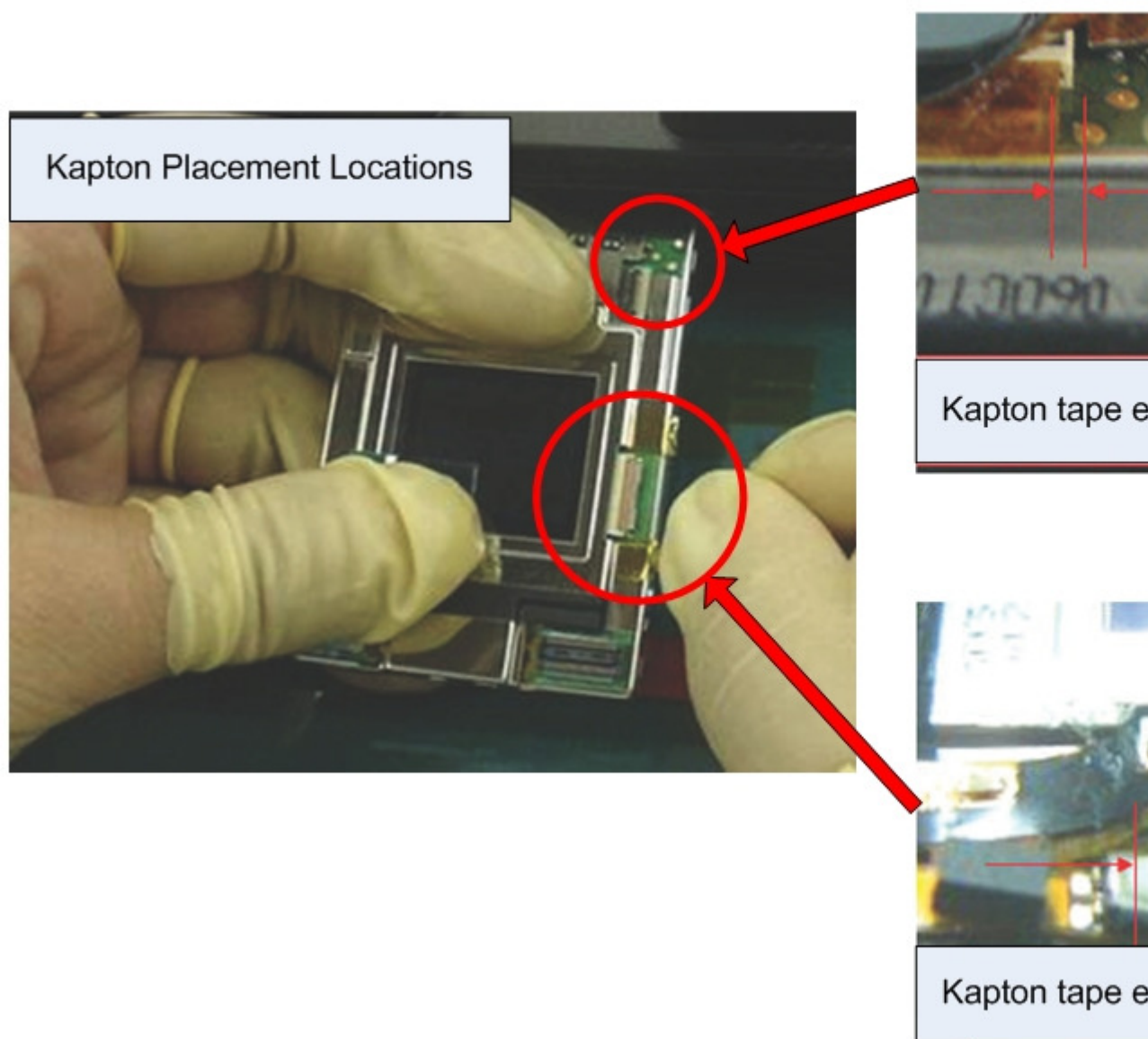

Service Inventory

No actions required, the P-Flex, the Display and the kapton tape are three separate parts.

CALL CENTER ACTION

Call center should advise callers to send phone for repair.

SERVICE ENTRY CODE

Global Service Codes

Complaint Code: AUD01 - Audio - Earpiece , No

Problem Found Code: AUD01 - Audio - Earpiece , No

Reference Designator:FLEX - Flex

Repair Code: RMP10 - Replace Mechanical Part - CSB/ FSB

If applicable, note this bulletin number on warranty claim forms and make necessary changes to service manuals.2007-65
© Copyright 2007 Motorola Inc. All Rights Reserved.

[Close](#) | [Print](#)