

**B2B Connector to Keypad**

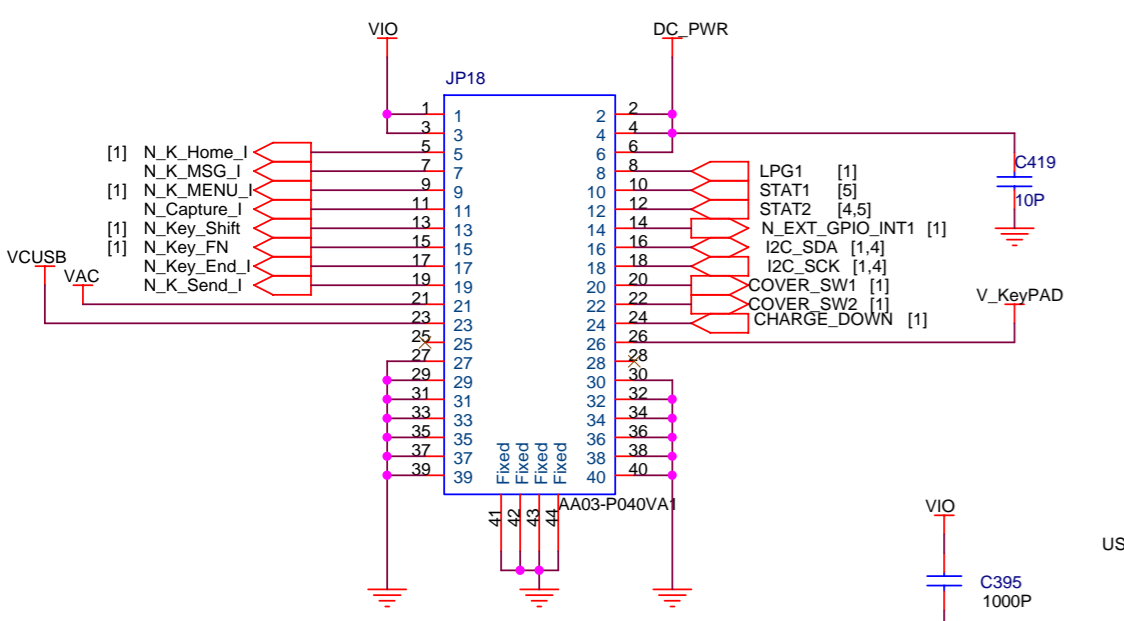

**Debug Connector**

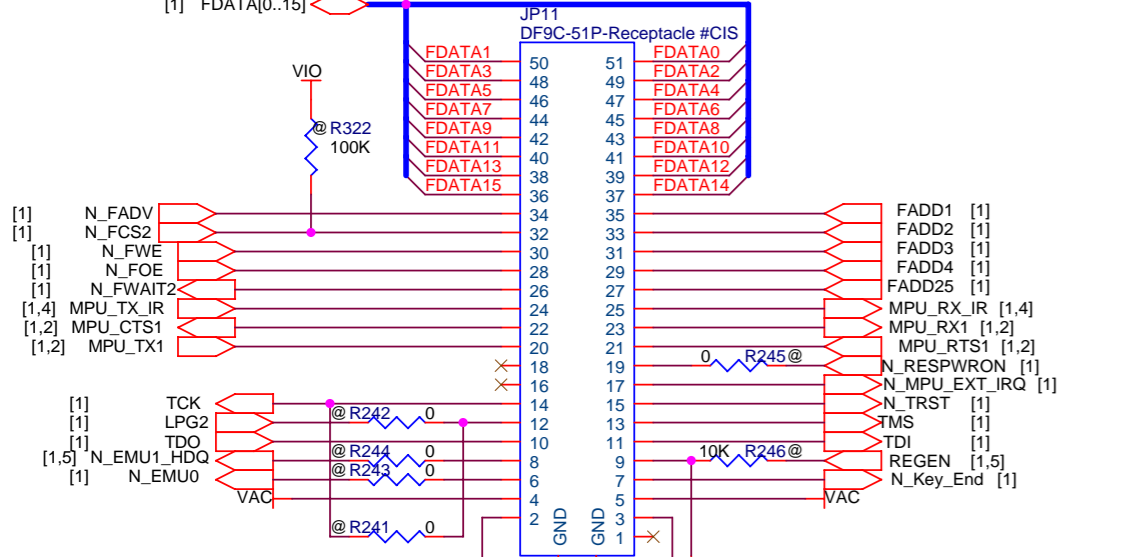

**SD slot**

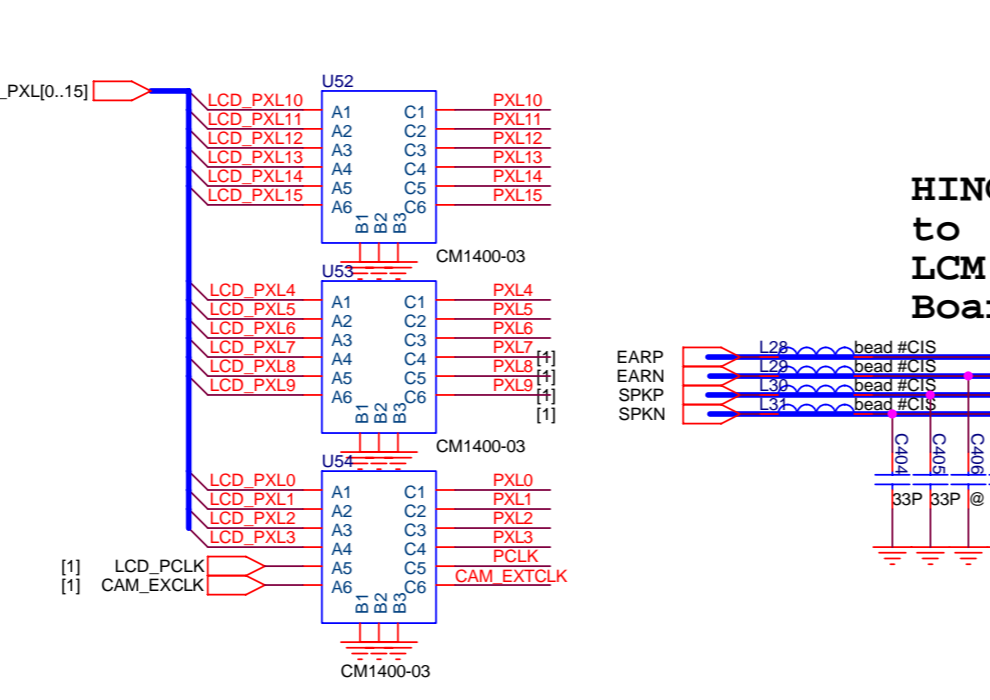

**HINGE to LCM Board**

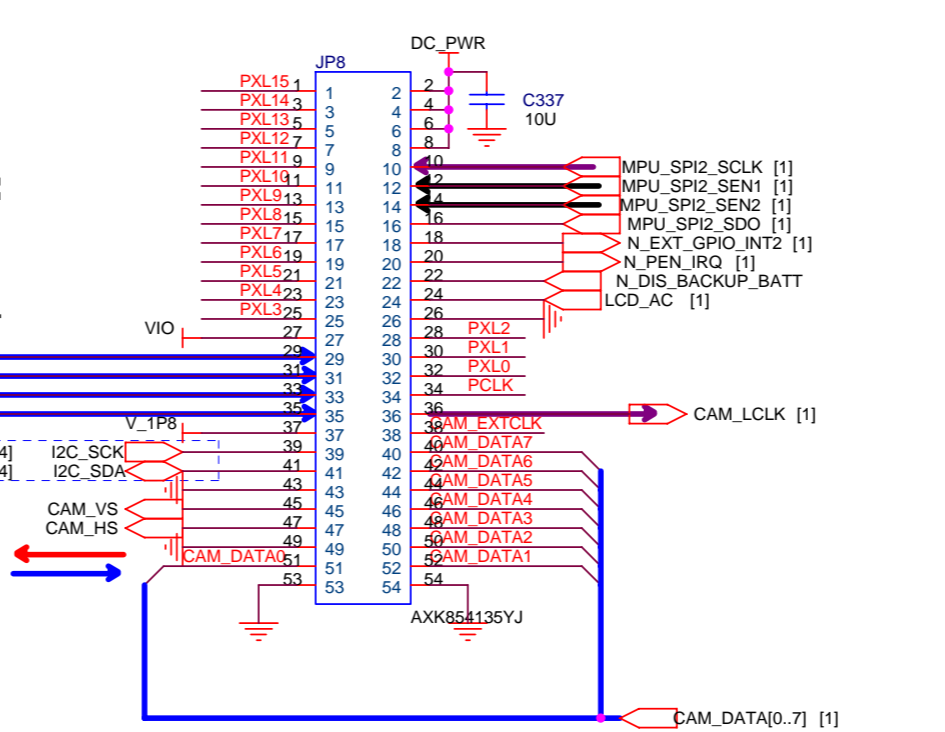

**CAM Board**

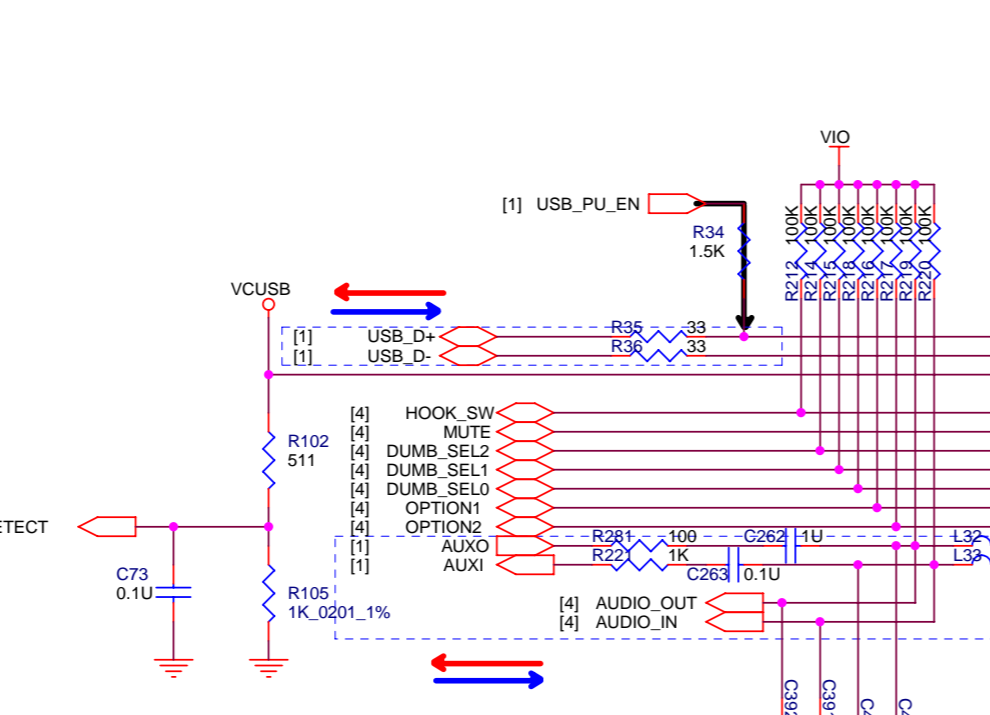

**USB and Audio Connections**

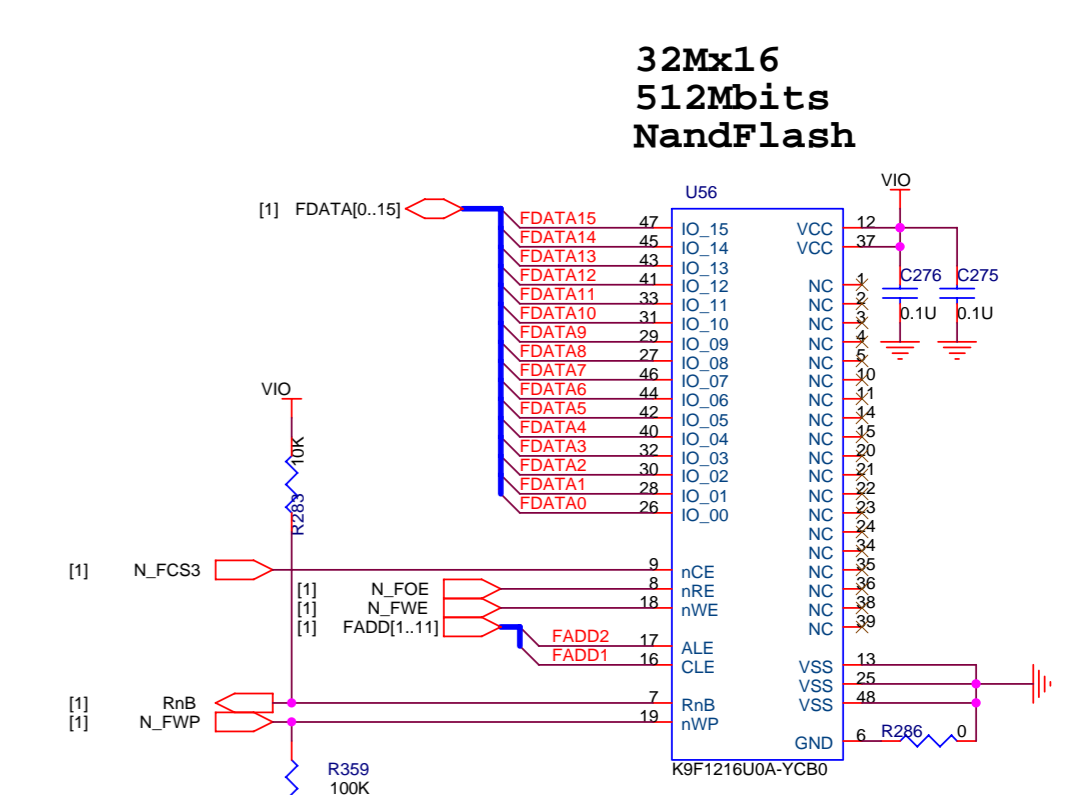

**32Mx16 512Mbits NandFlash**

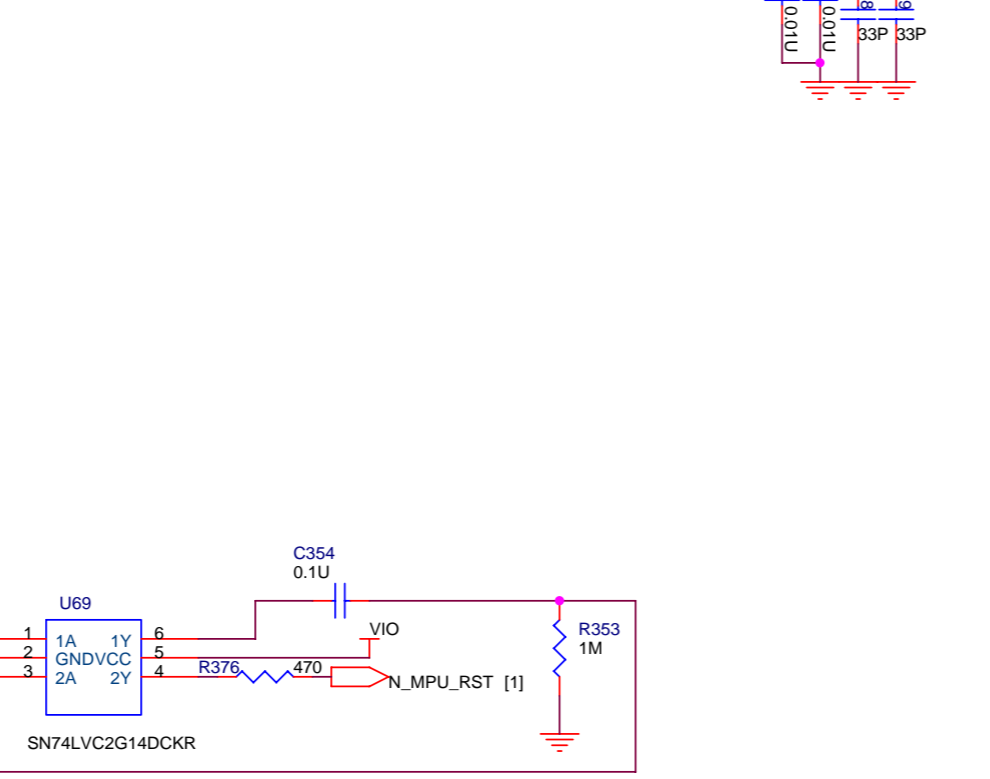

**WLAN Module**

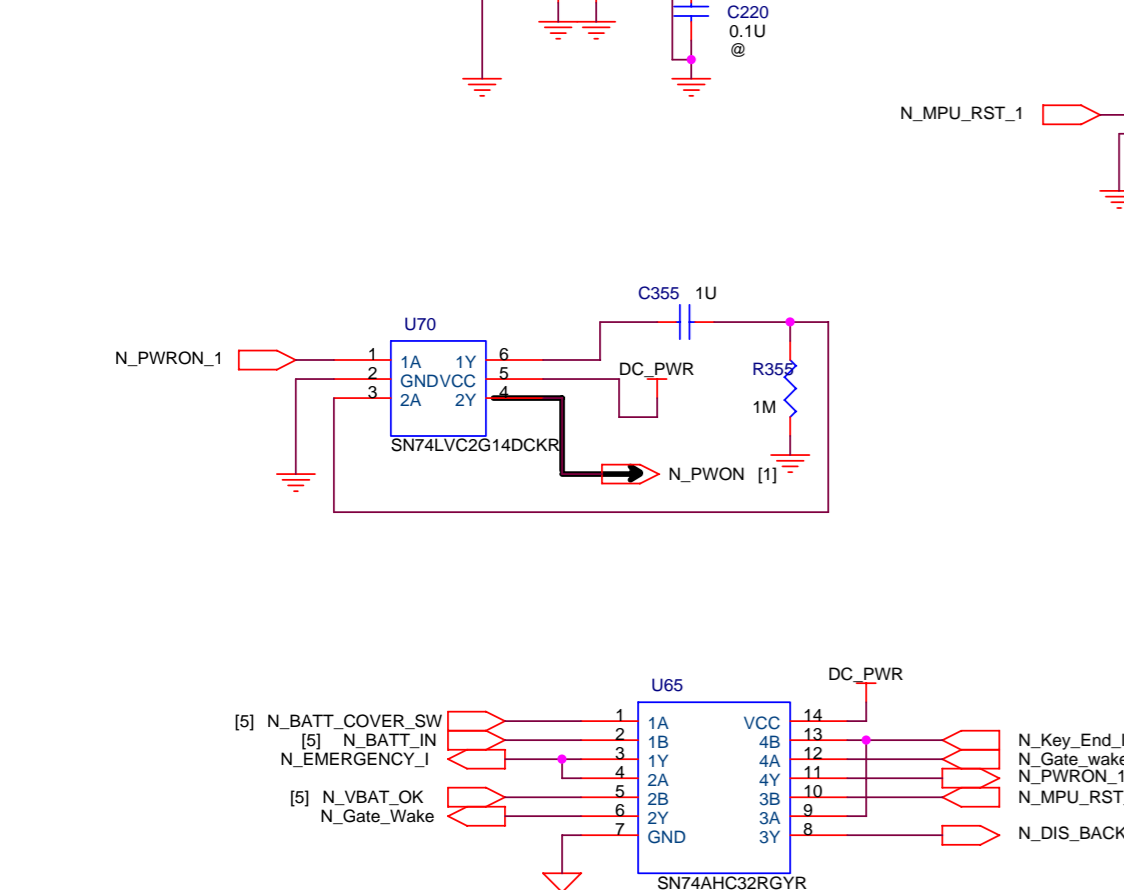
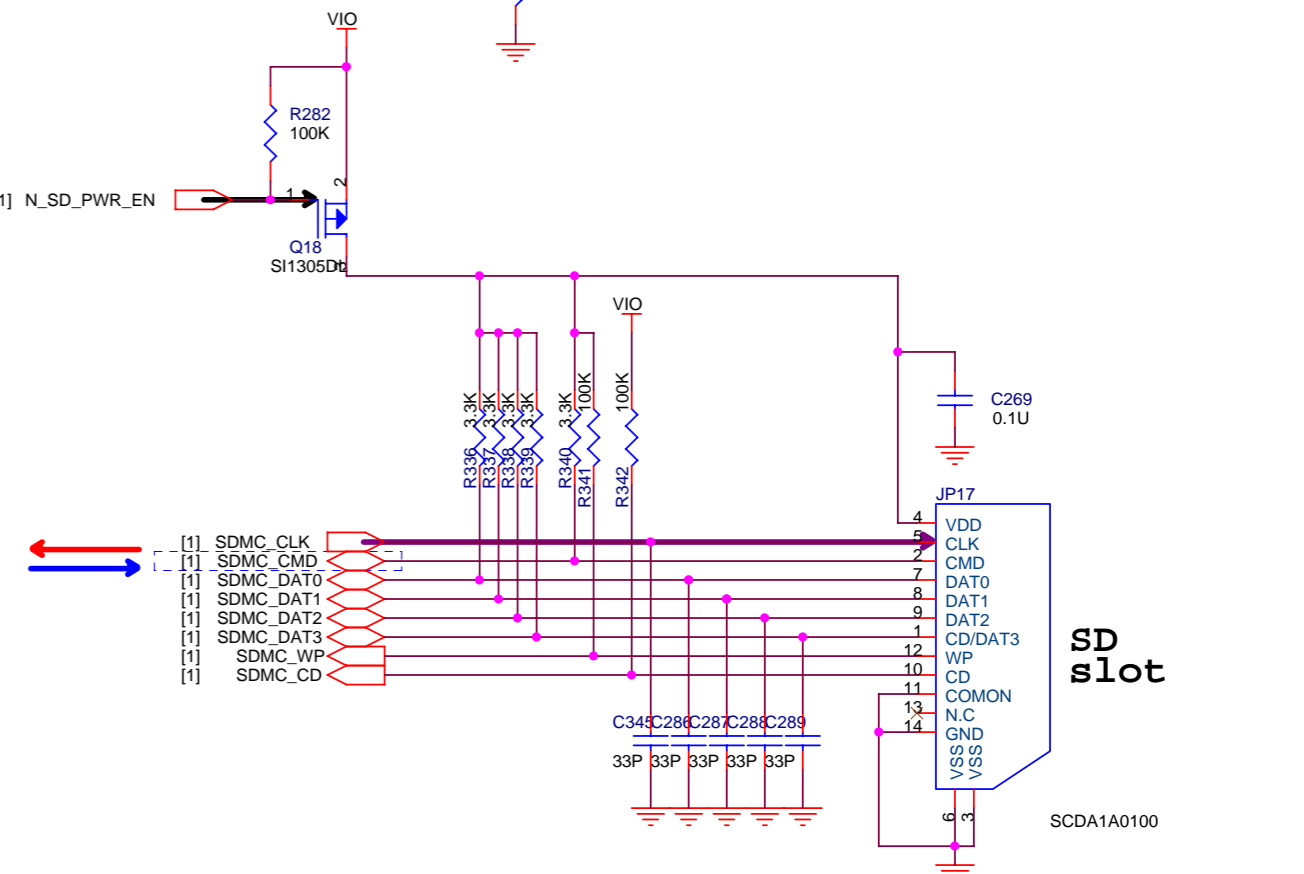

### Internal MIC

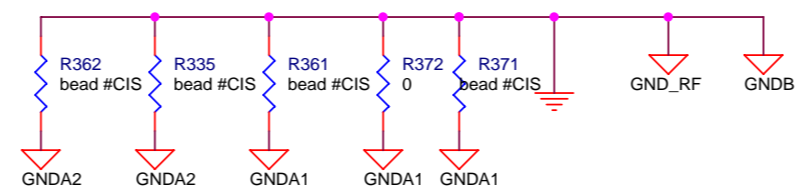
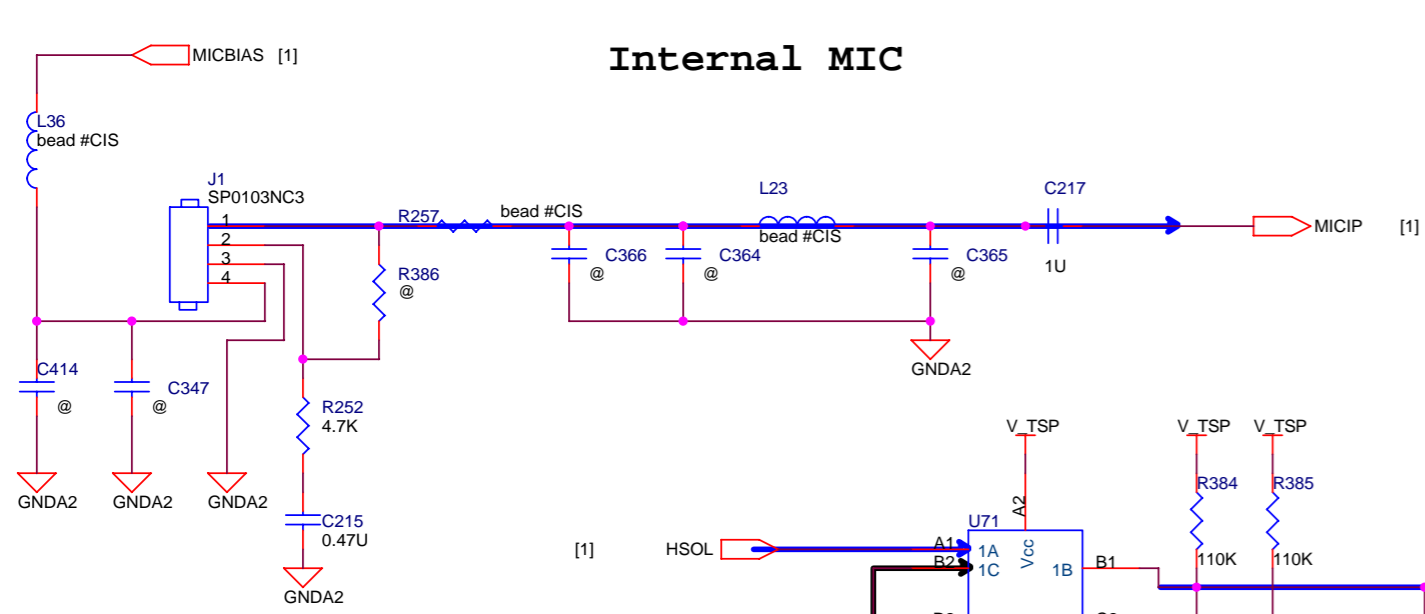

### 4 Rings PhoneJack

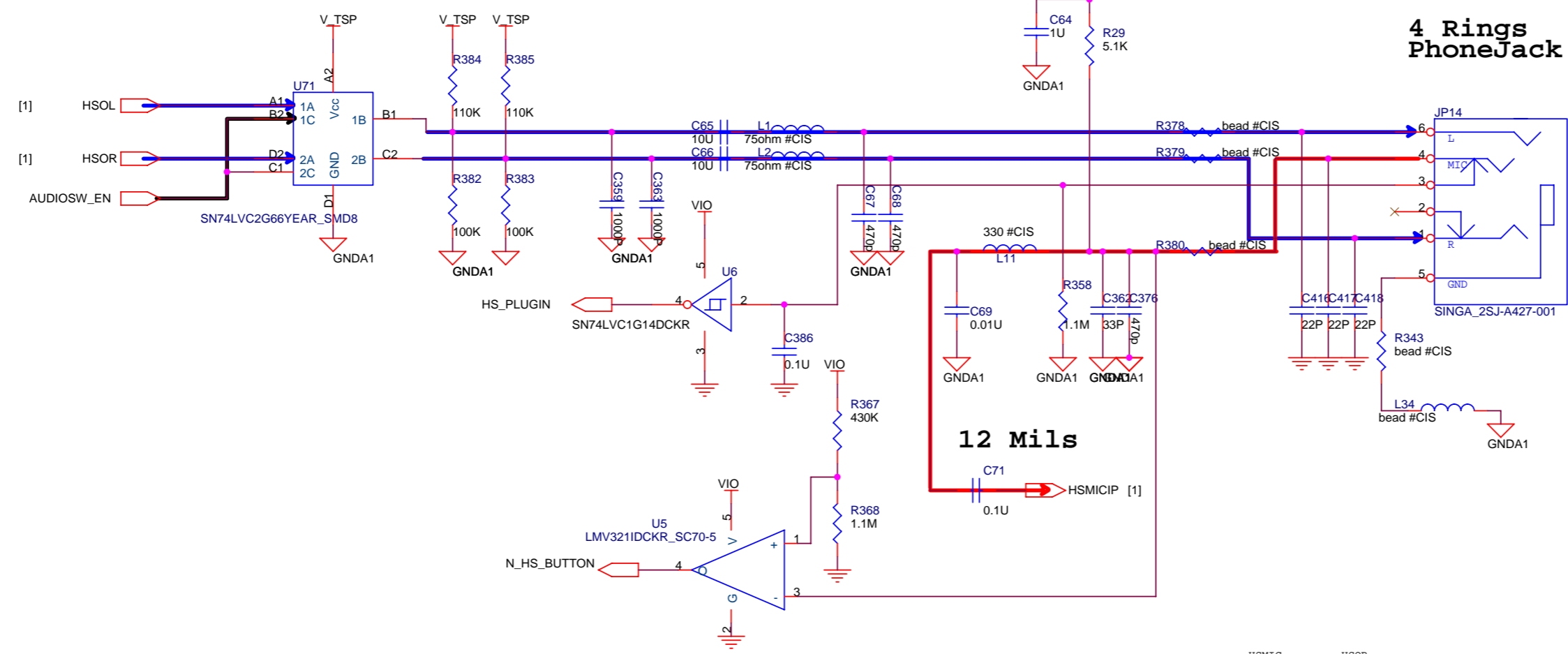

### 12 Mils

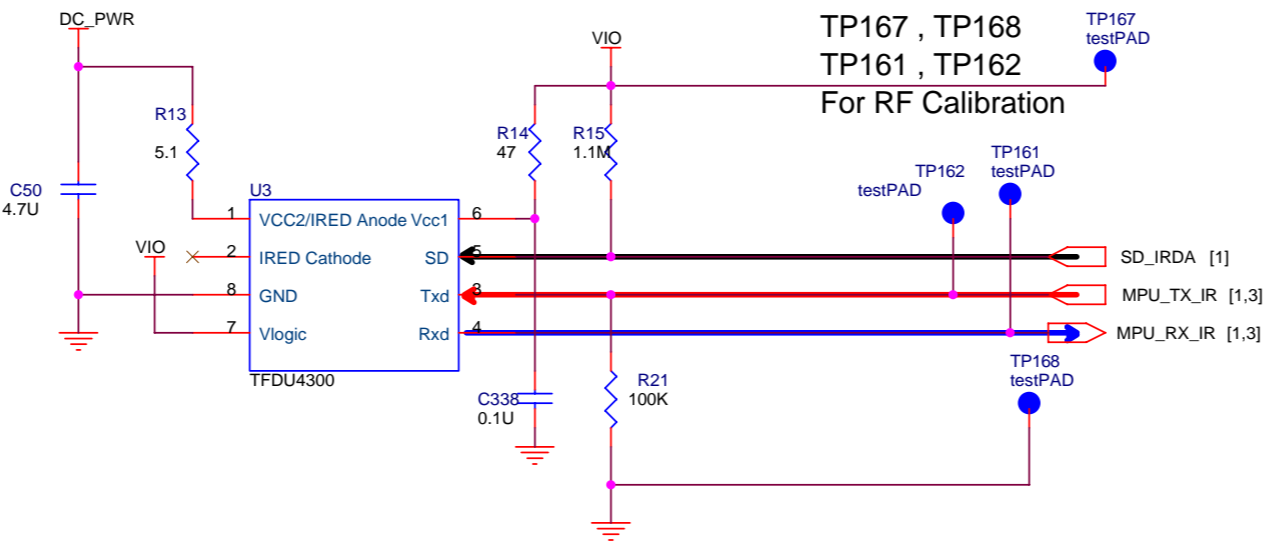
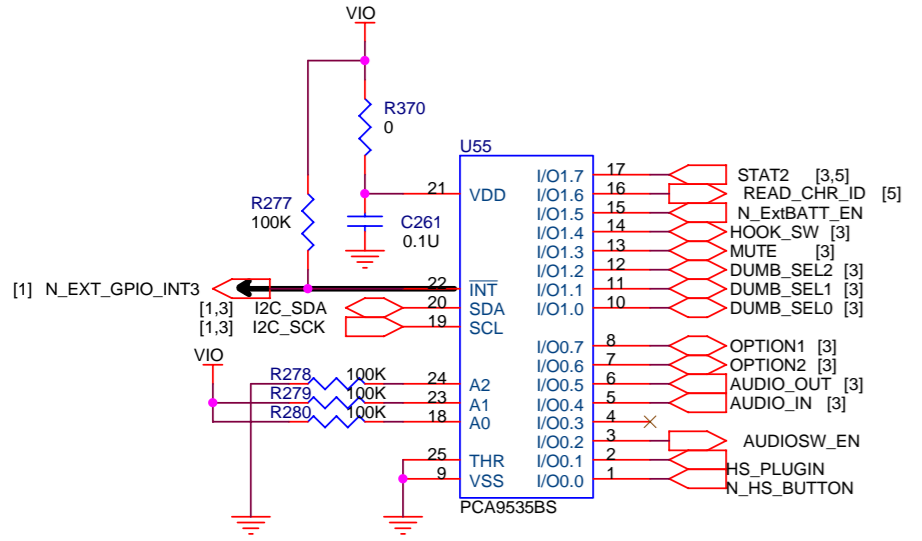
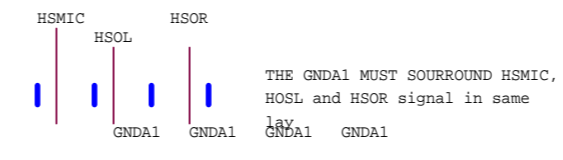
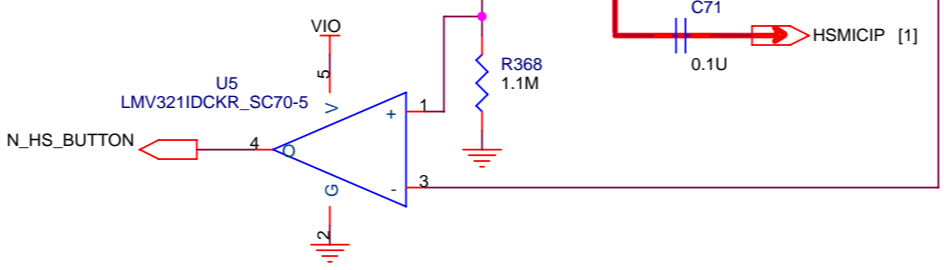

# Charger Circuit

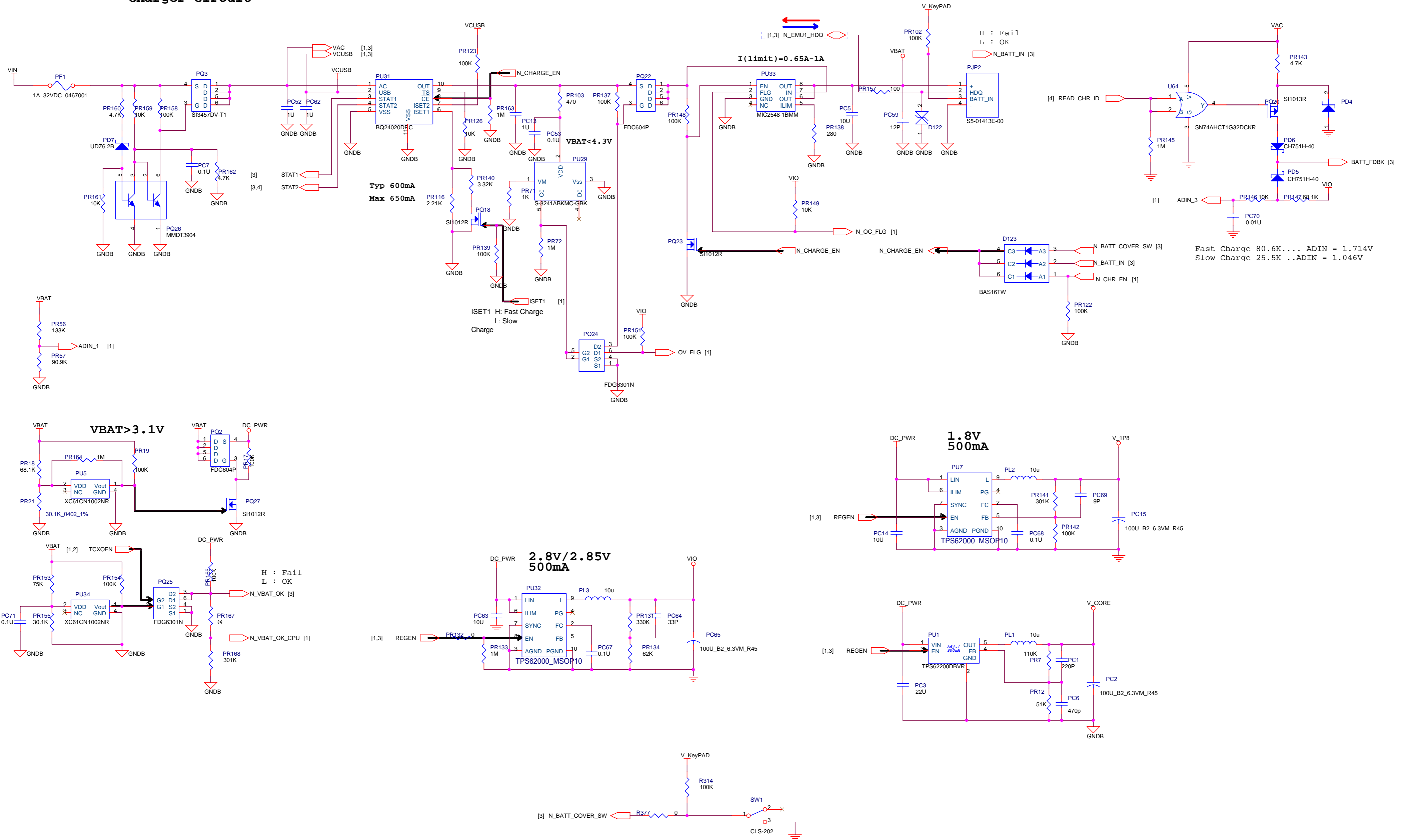

When DC\_PWR = 4.2V ---- 2.887  
When DC\_PWR = 3.1V ---- 2.13V