

COMPAL ELECTRONICS, INC.

Title: **CPU & ABB**
 Size: **A2**
 Document Number: **MPX300 Main Board**
 Rev: **0.6**

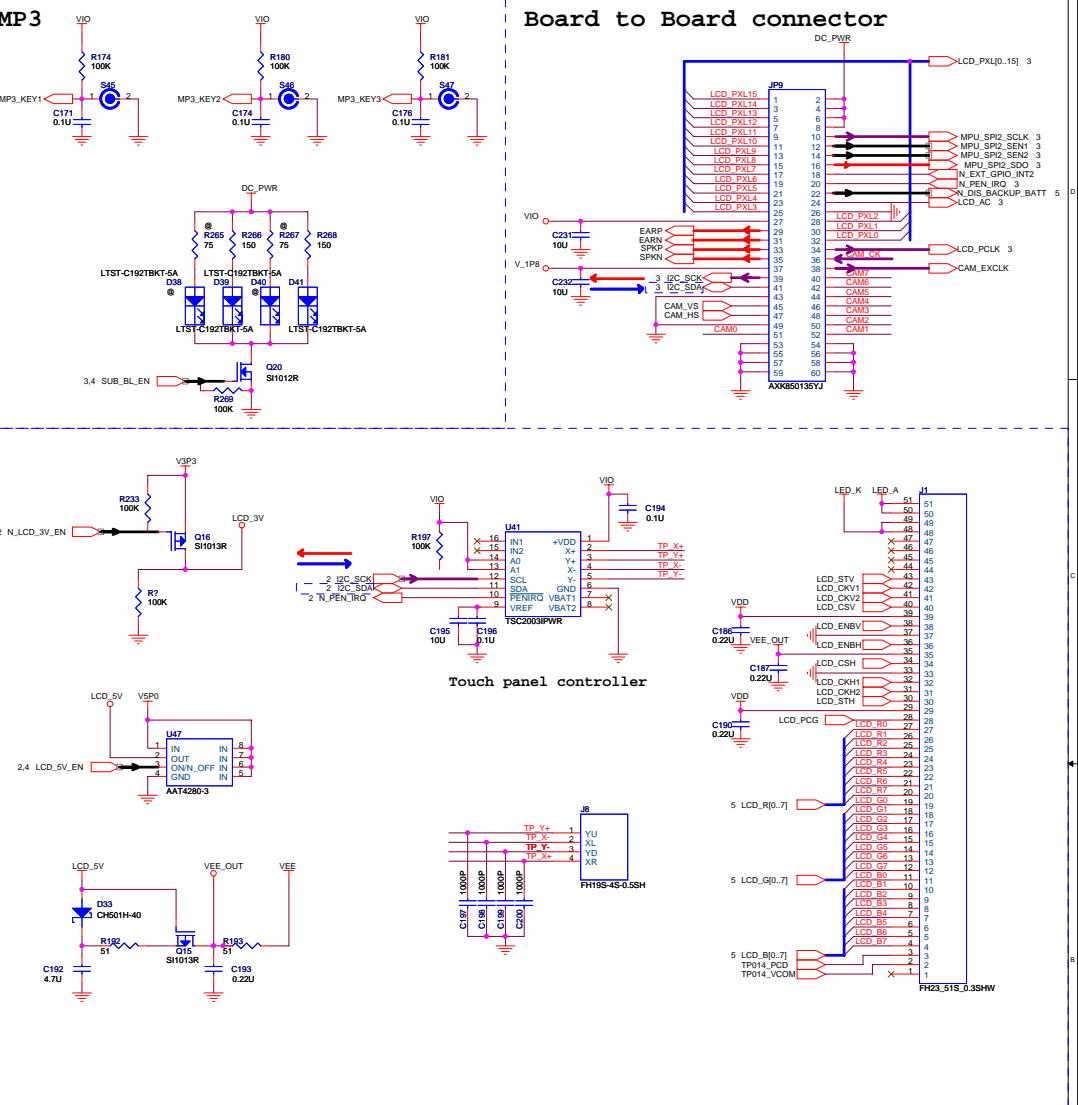

CLI, Main Display voltage

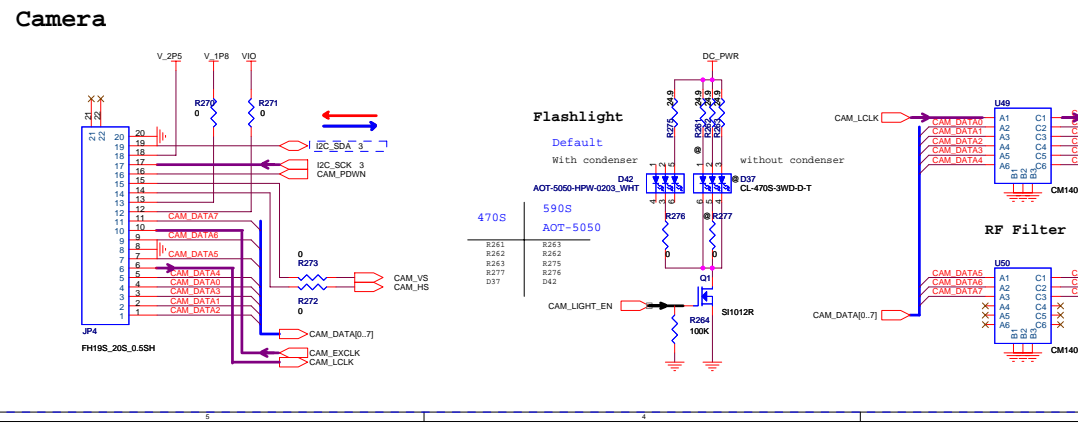
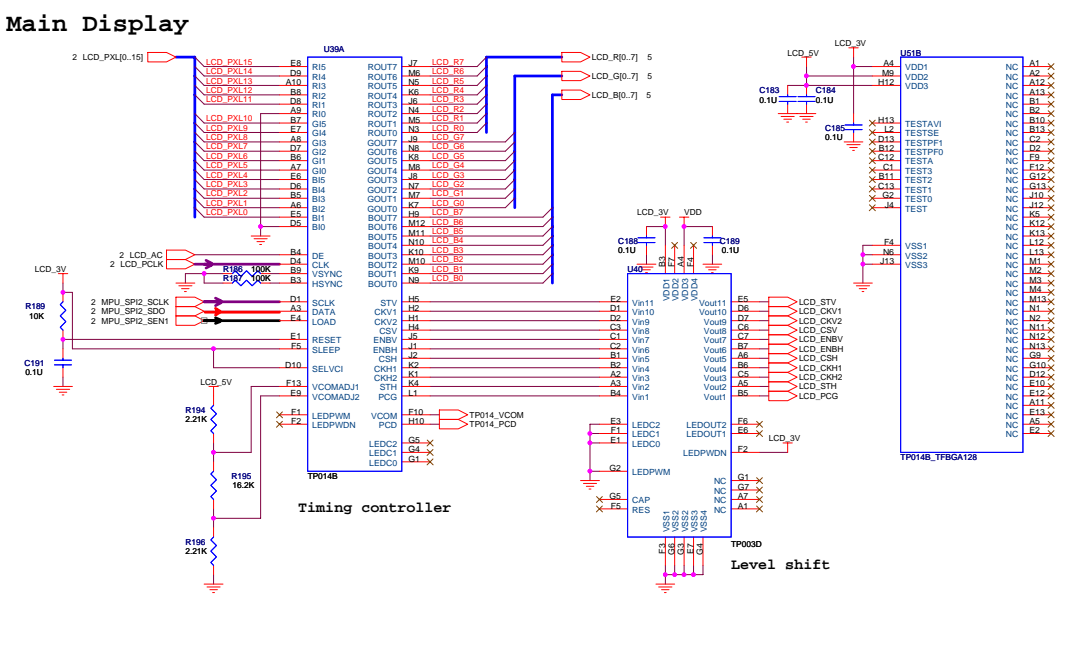
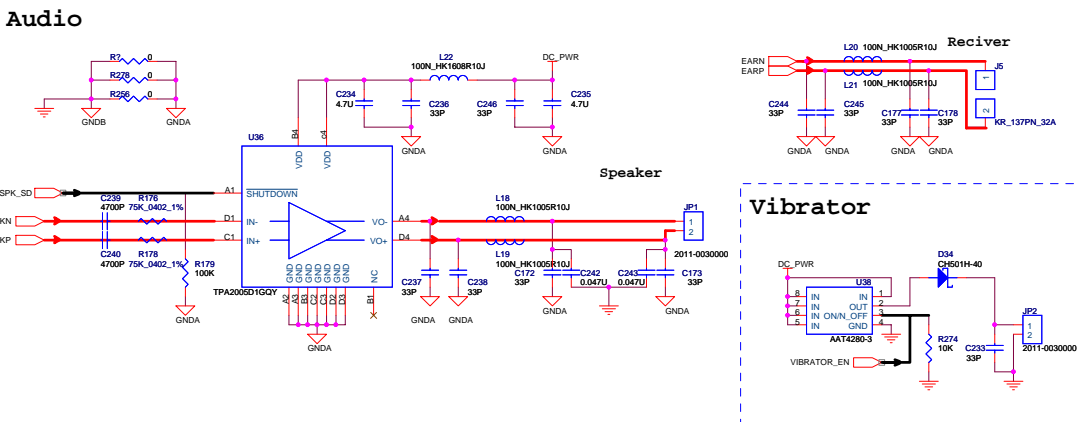
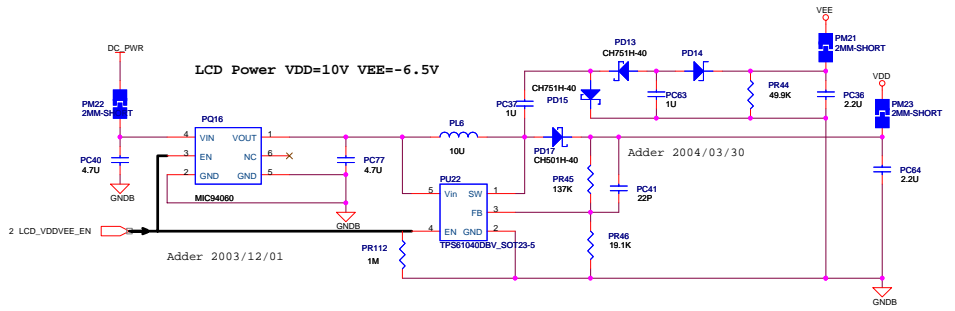
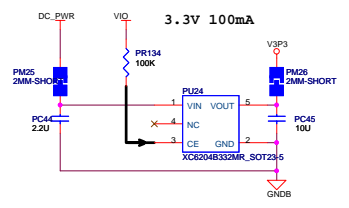
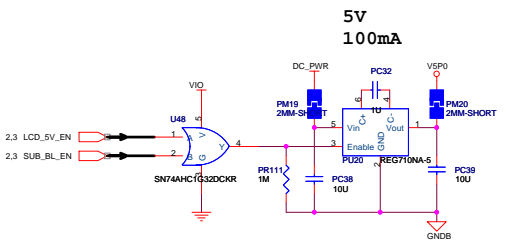

Camera analog voltage

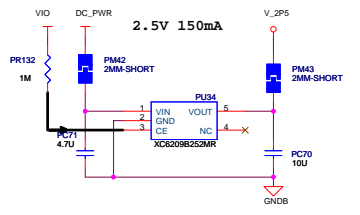

LIGHT_EN	ADJ1	ADJ2	LIGHT STATE	CURRENT
0	0	0	OFF	0 mA
1	0	0	1/20	1 mA
1	1	0	1/3	6 mA
1	0	1	2/3	12 mA
1	1	1	FULL	17 mA

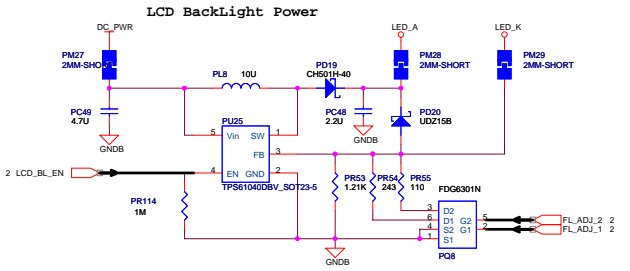

Backup battery function

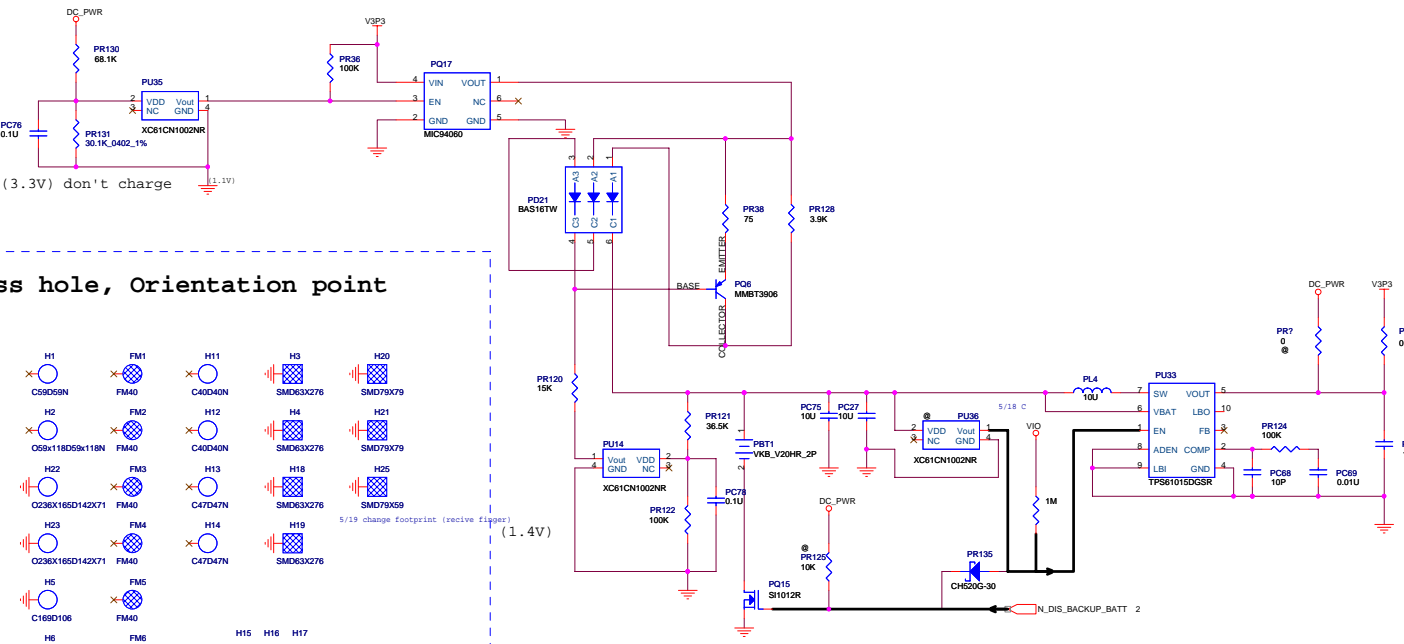

Boss hole, Orientation point

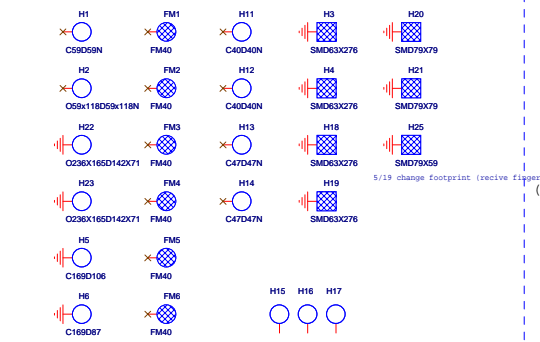

EMI Filter

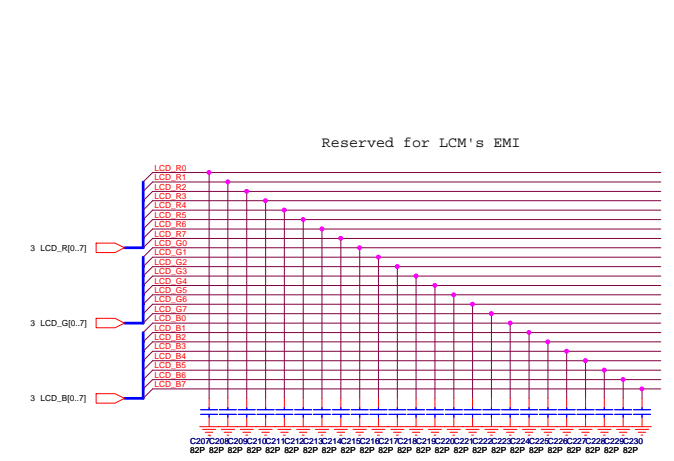

Indicate LED

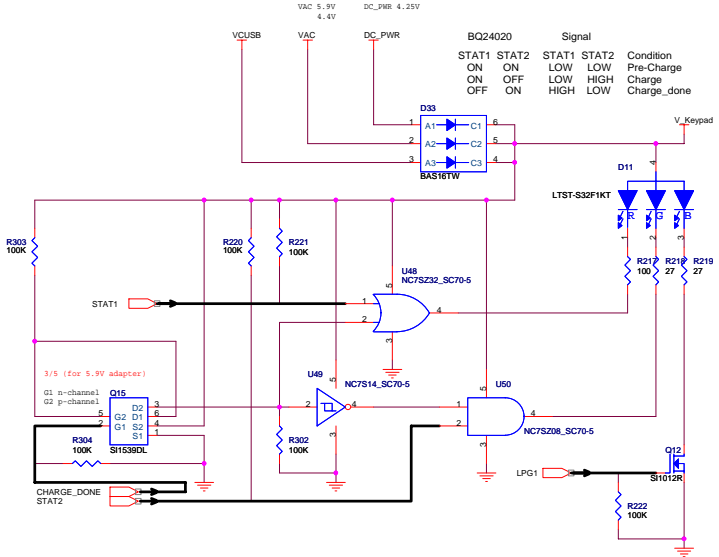

Magent sensor

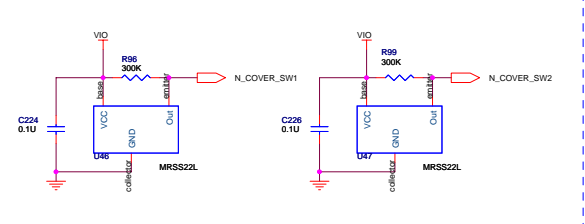

Keypad LED

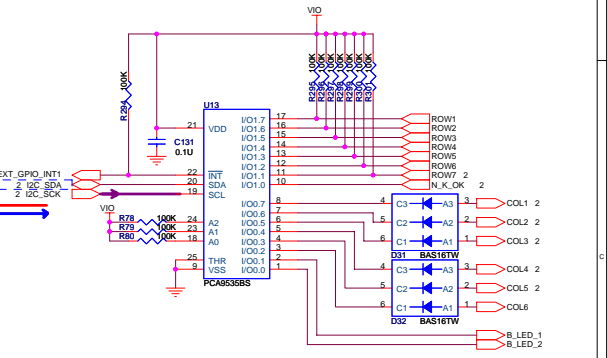
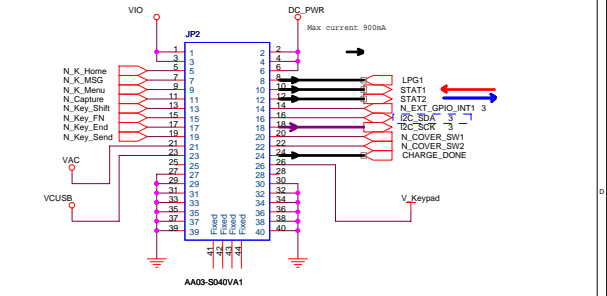
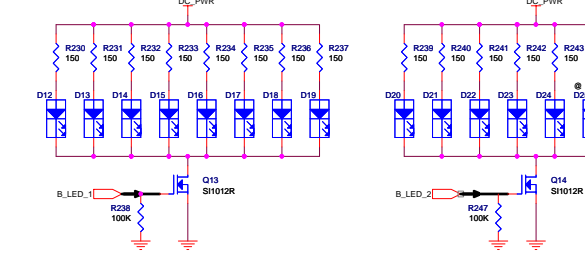

Key array

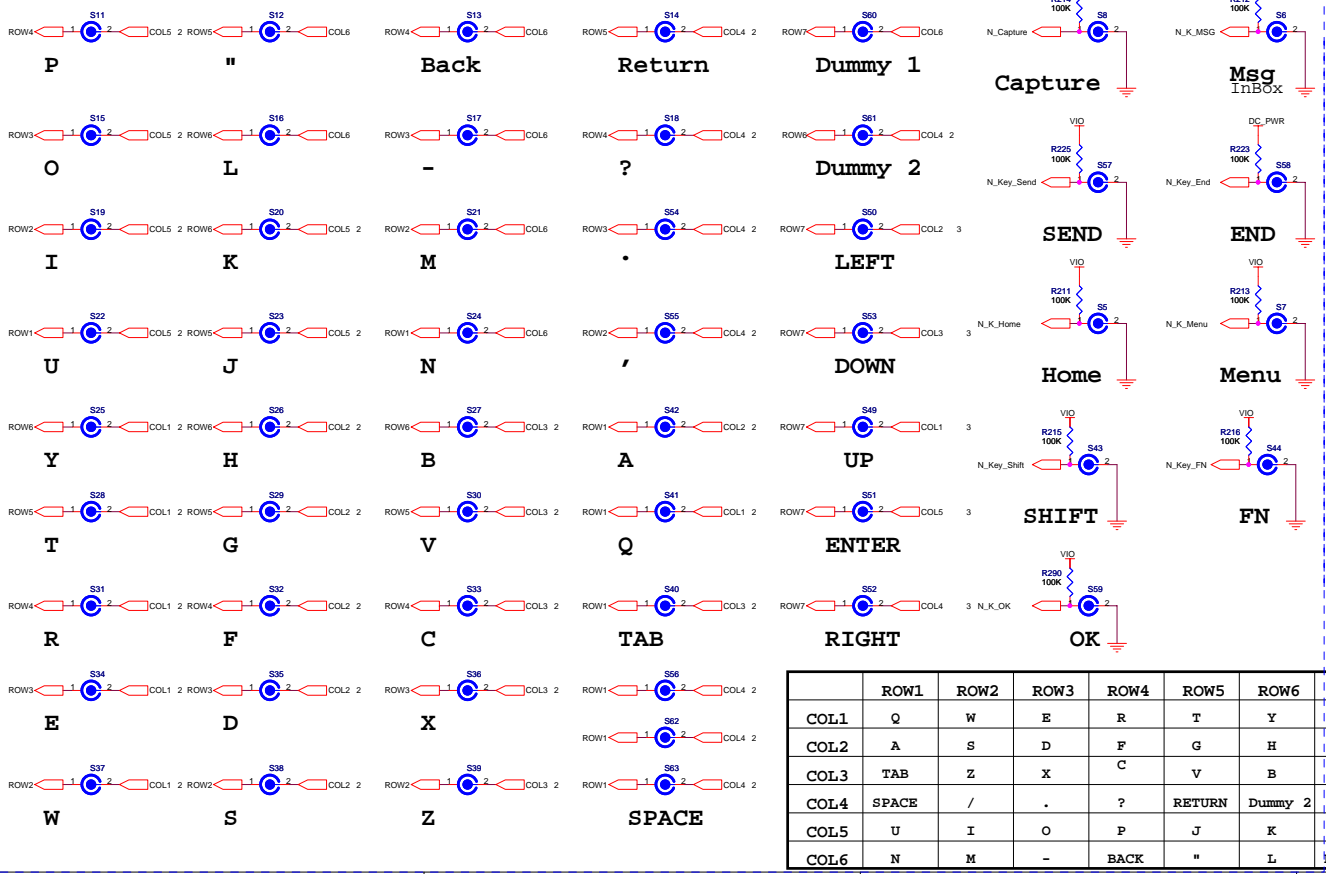

Hinge FPC

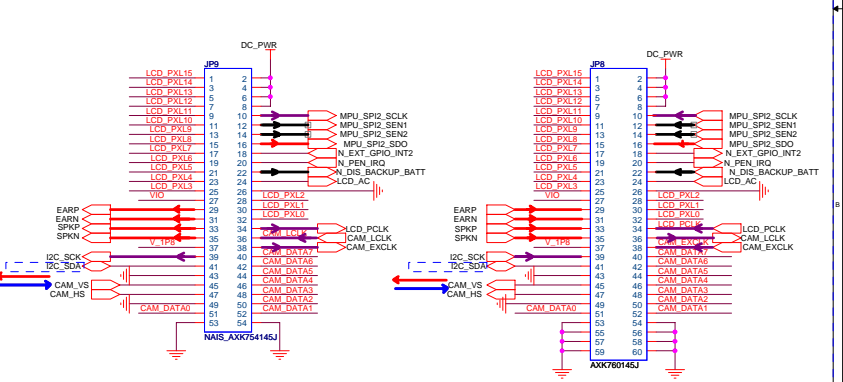

	ROW1	ROW2	ROW3	ROW4	ROW5	ROW6	ROW7
COL1	Q	W	E	R	T	Y	UP
COL2	A	S	D	F	G	H	Left
COL3	TAB	Z	X	C	V	B	Down
COL4	SPACE	/	.	?	RETURN	Dummy 2	Right
COL5	U	I	O	P	J	K	Enter
COL6	N	M	-	BACK	"	L	Dummy 1

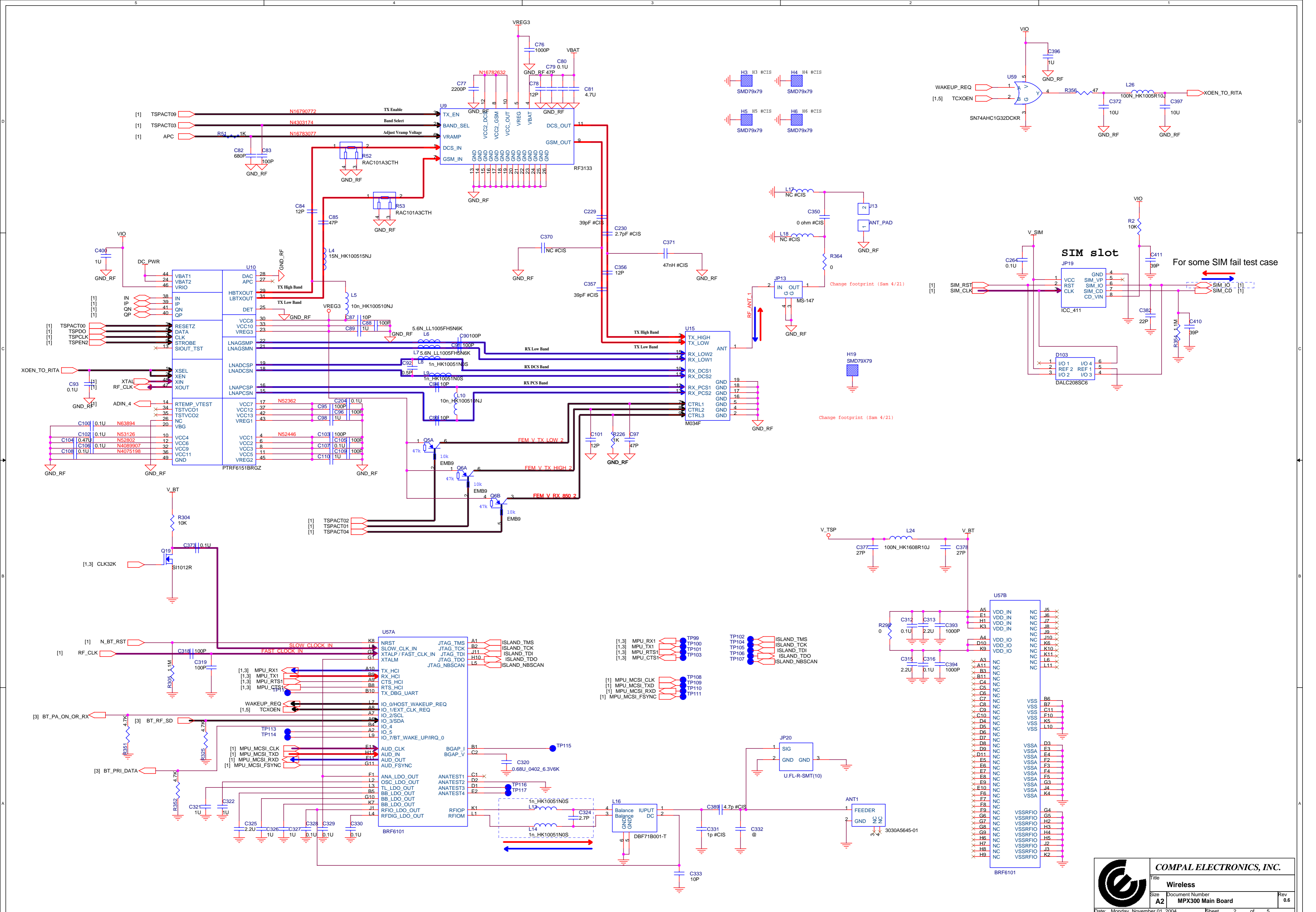

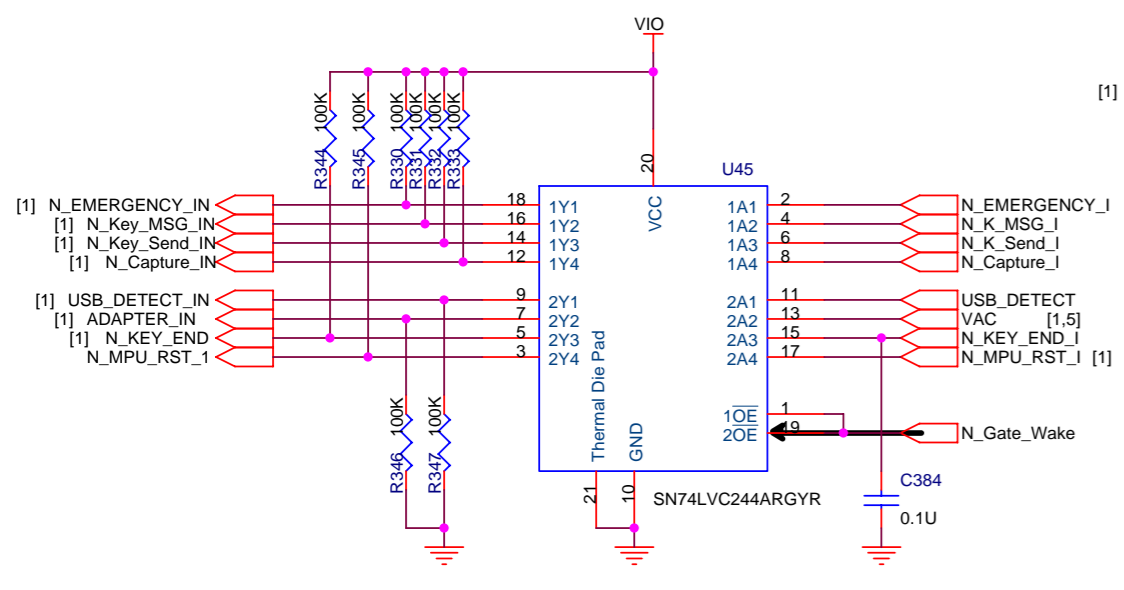

B2B Connector to Keypad

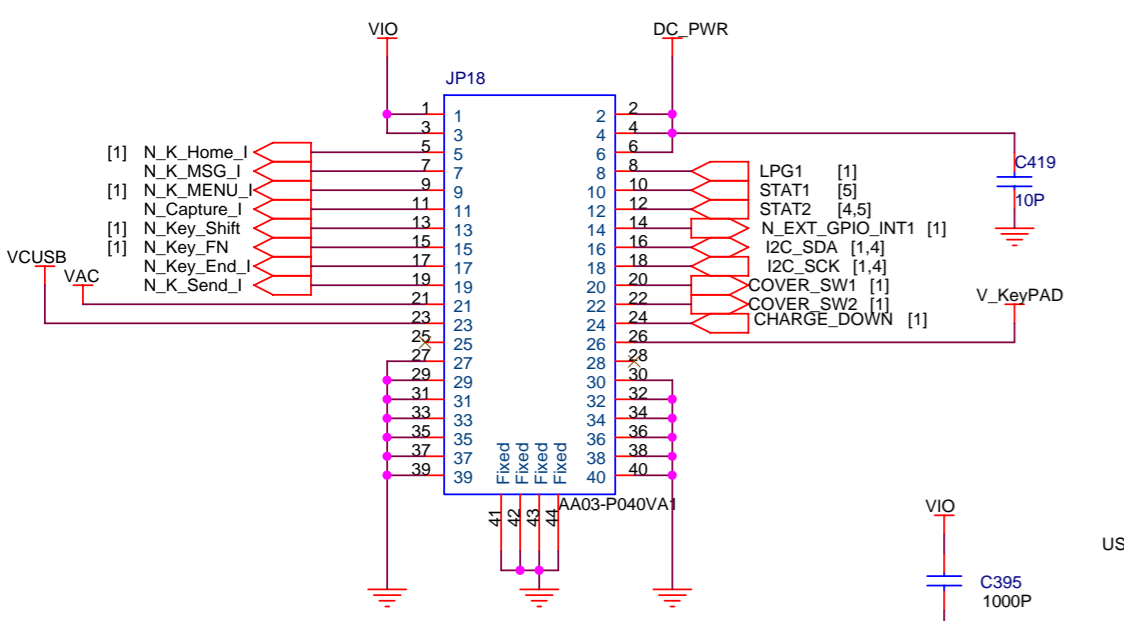

Debug Connector

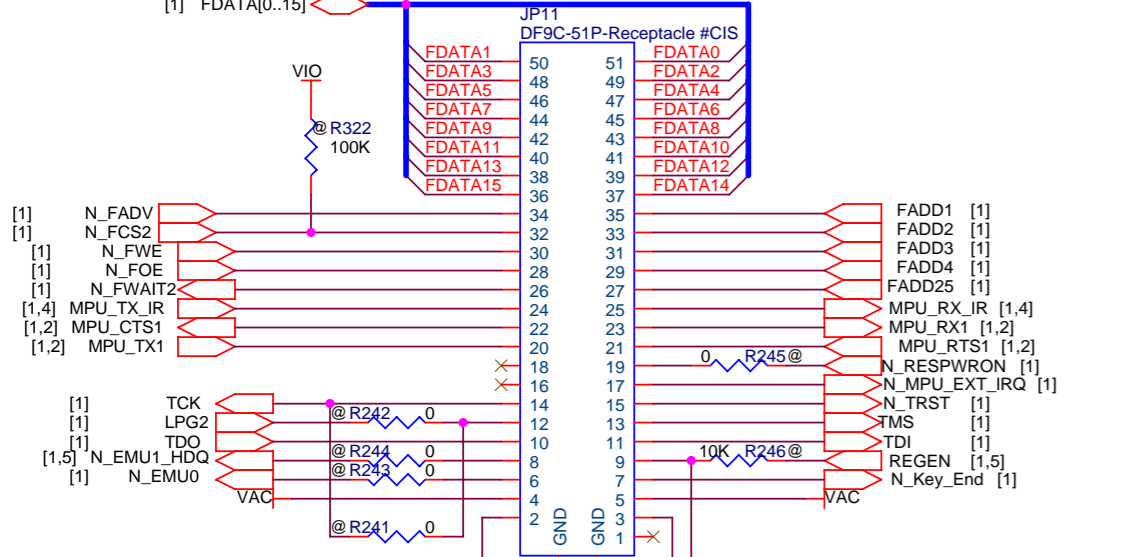

SD slot

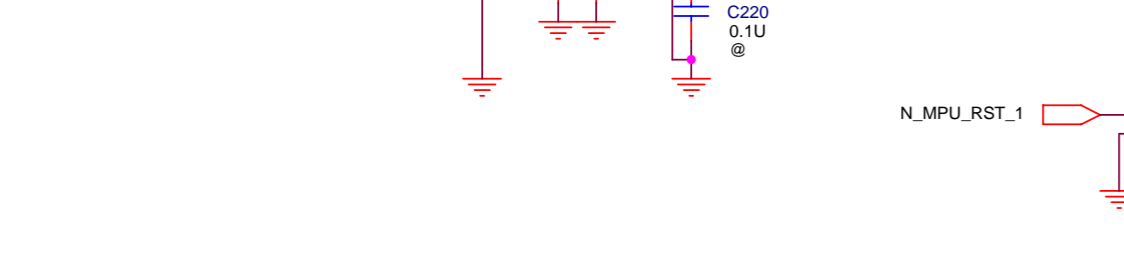

WLAN Module

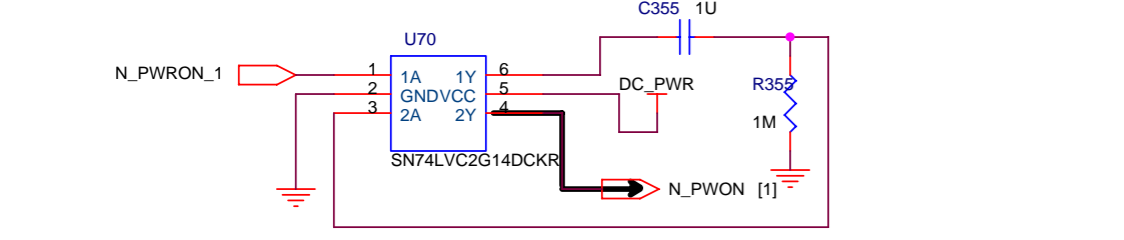

HINGE to LCM Board

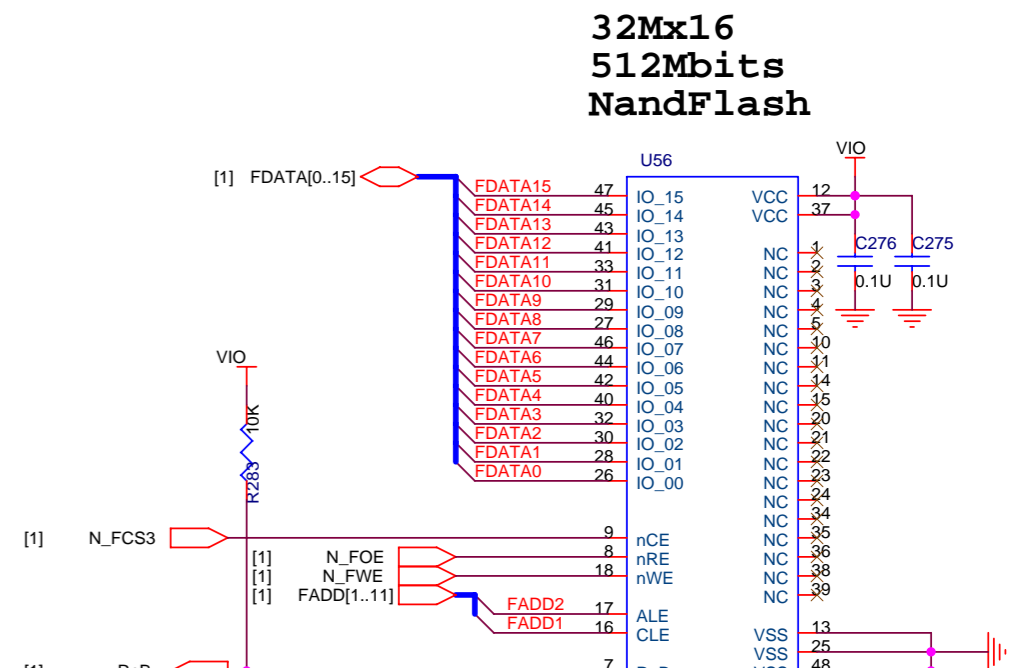
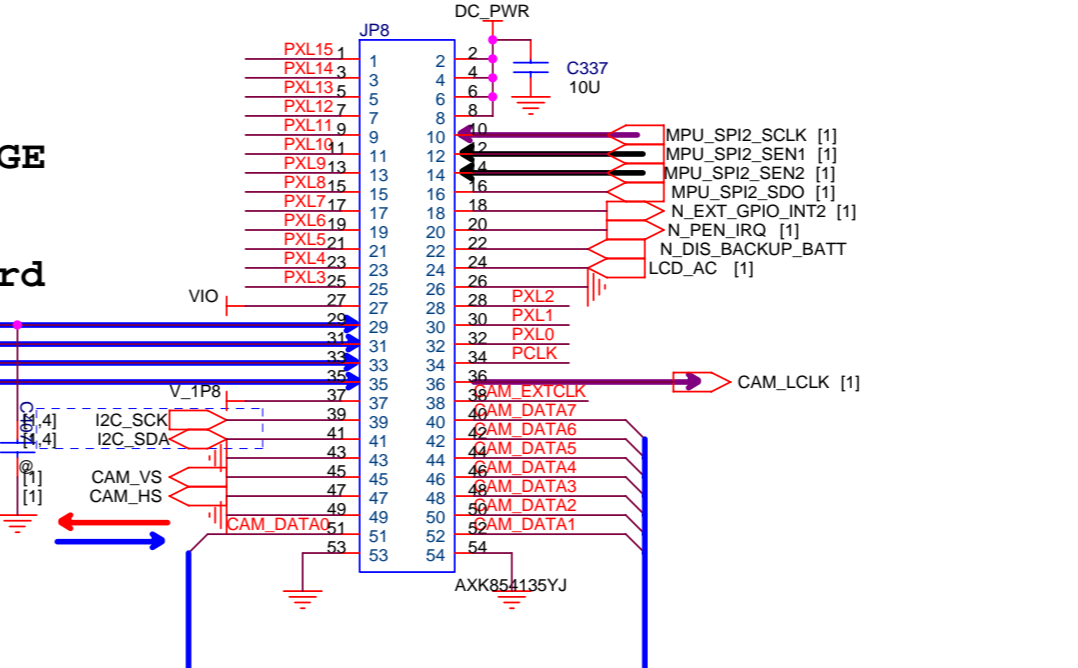
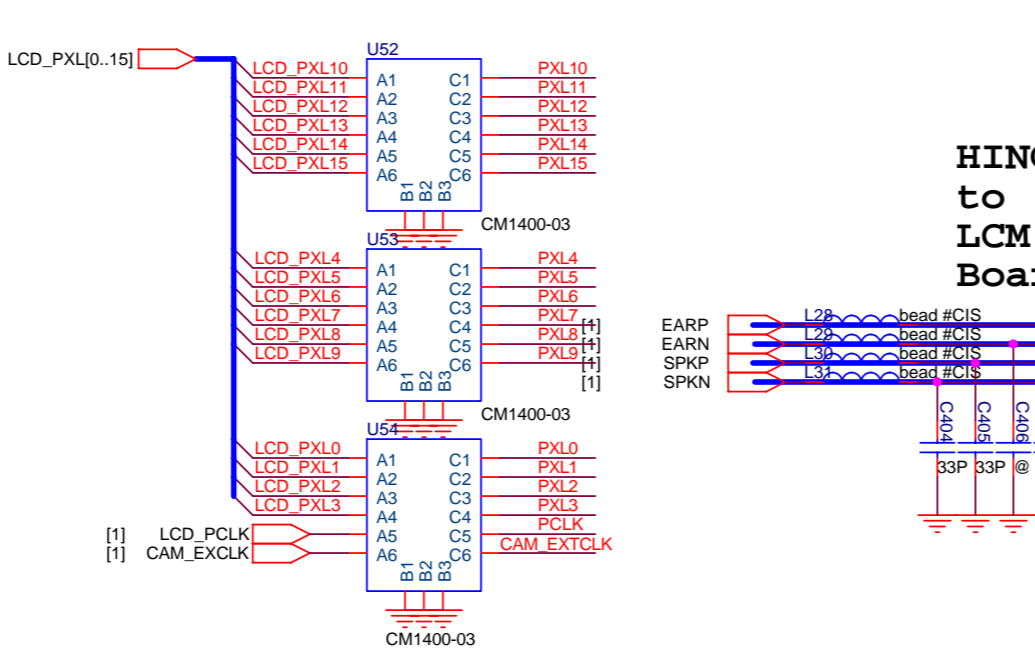
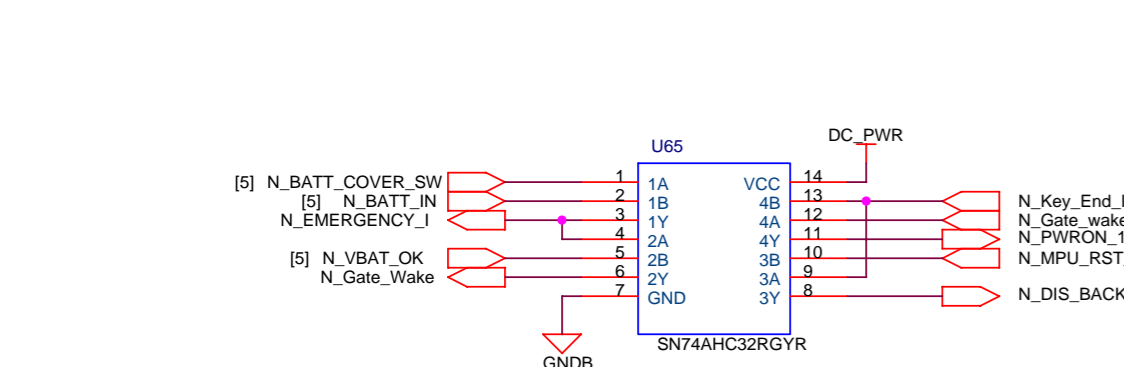

32Mx16 512Mbits NandFlash

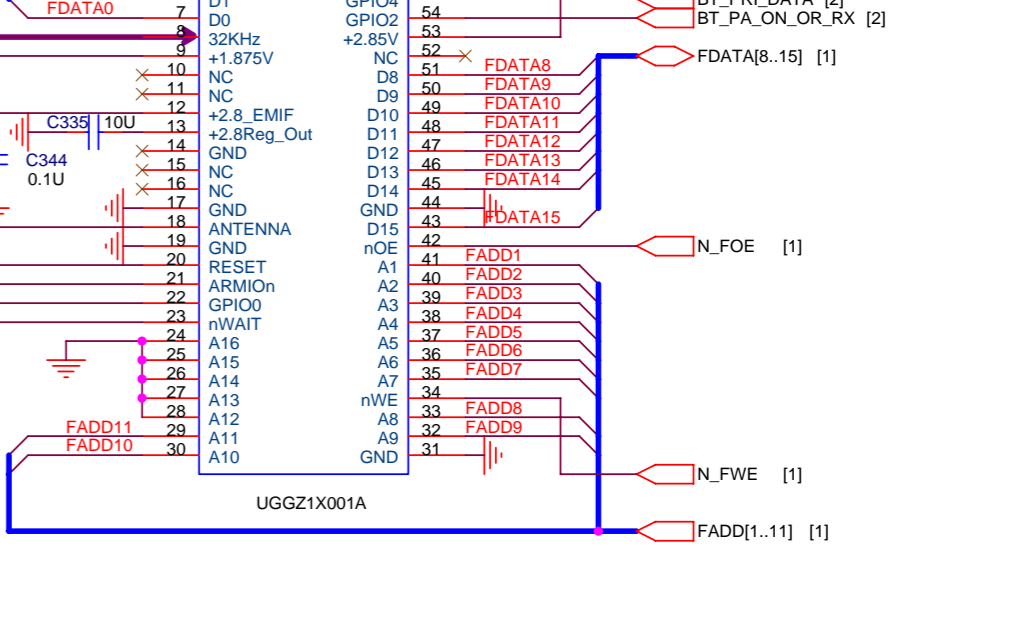
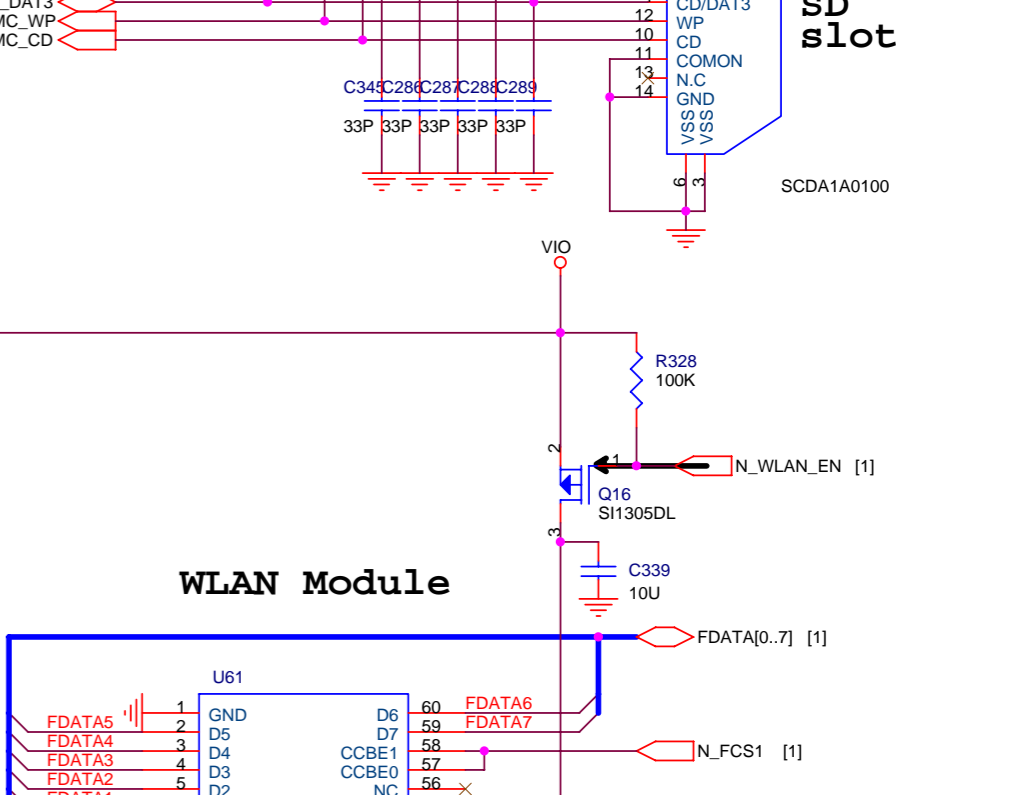
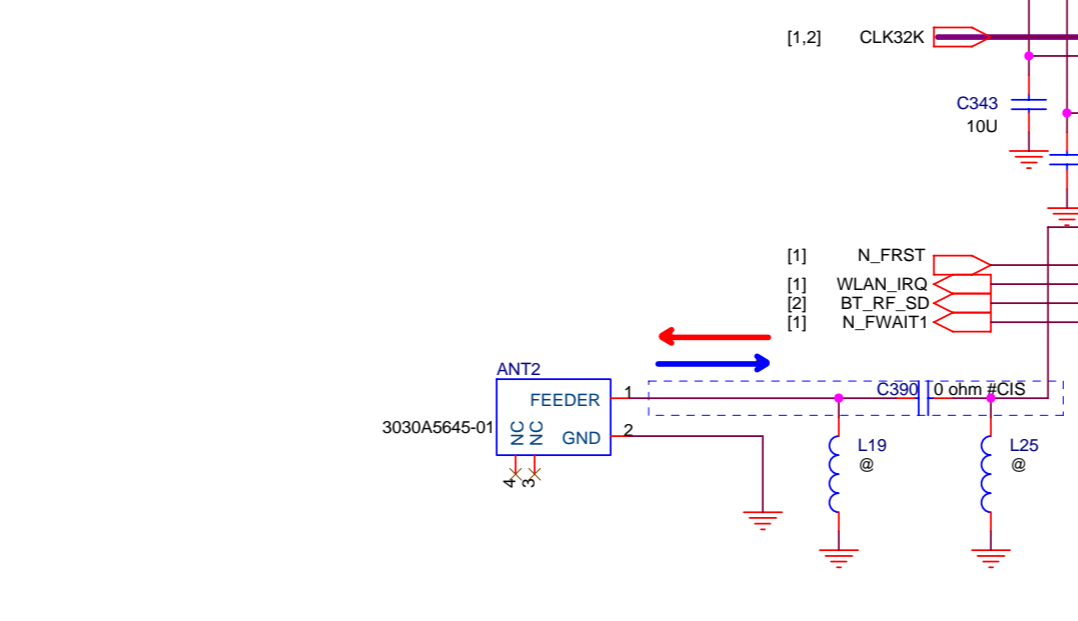
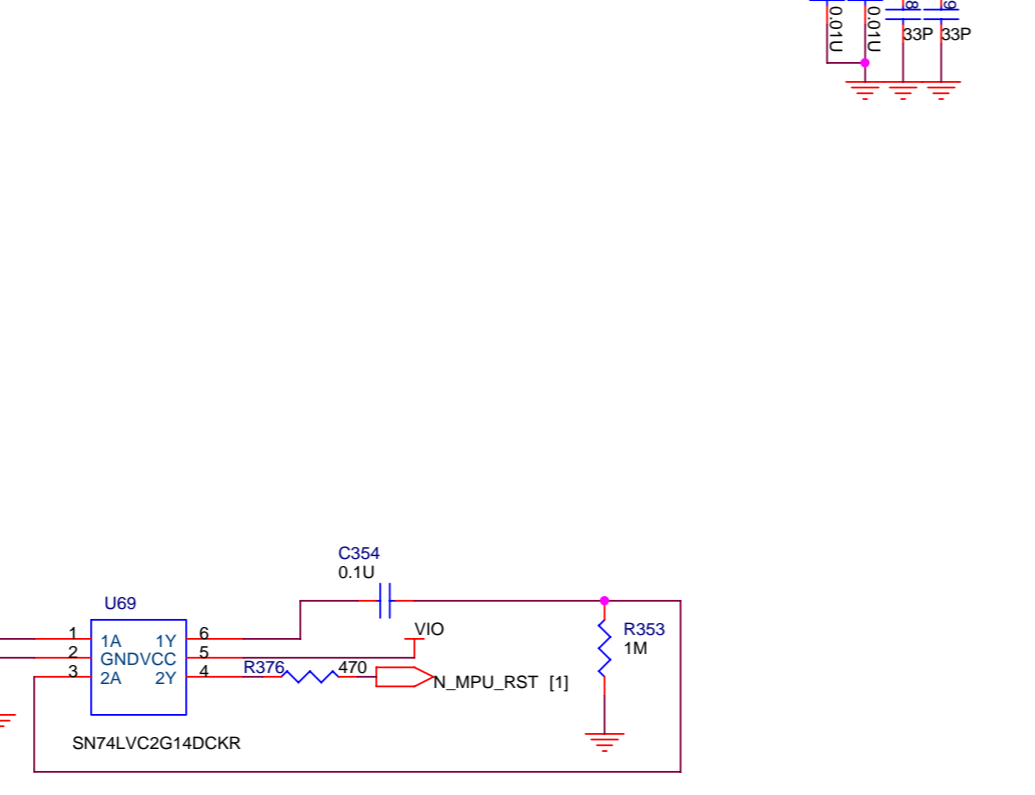
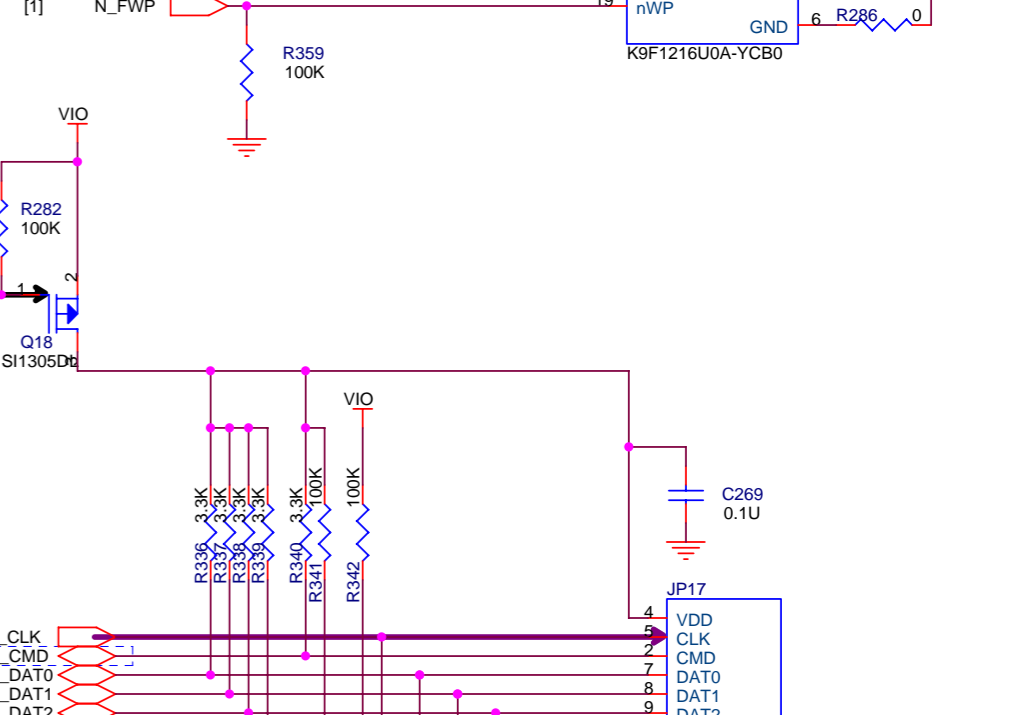
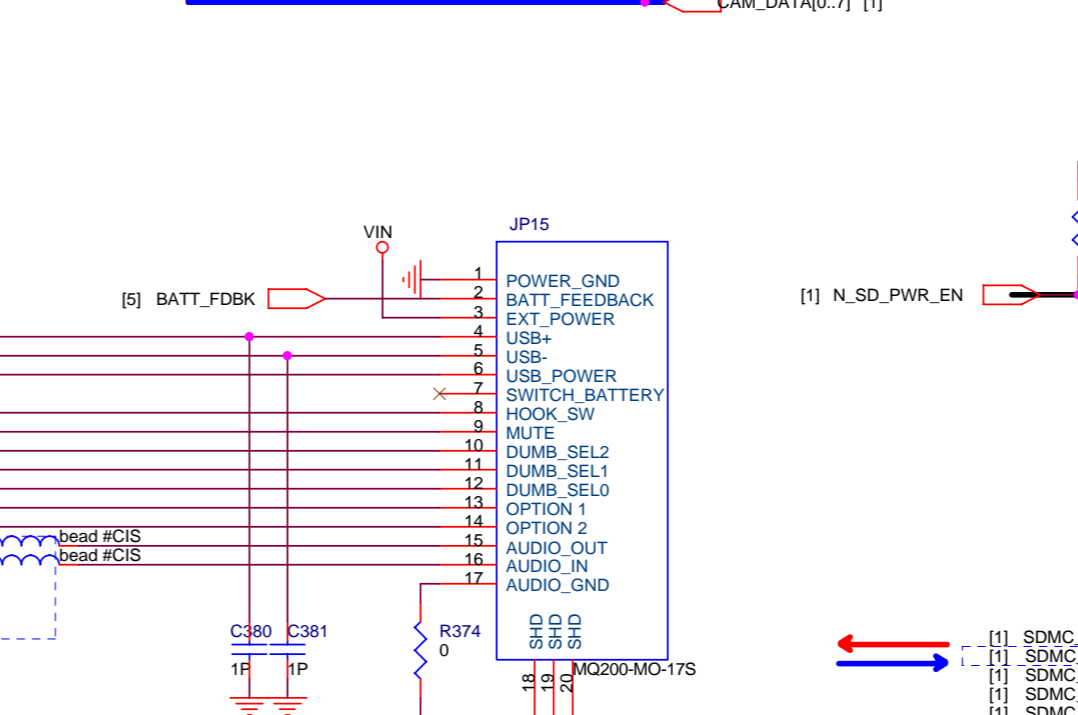
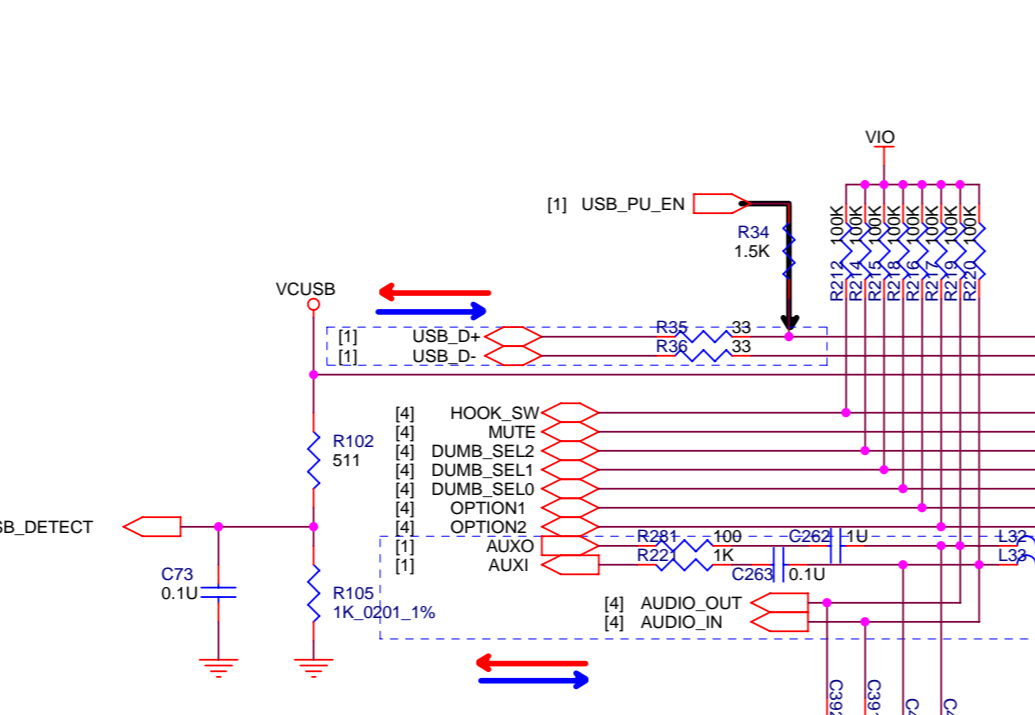

Internal MIC

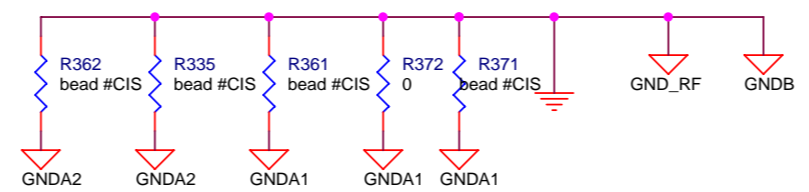
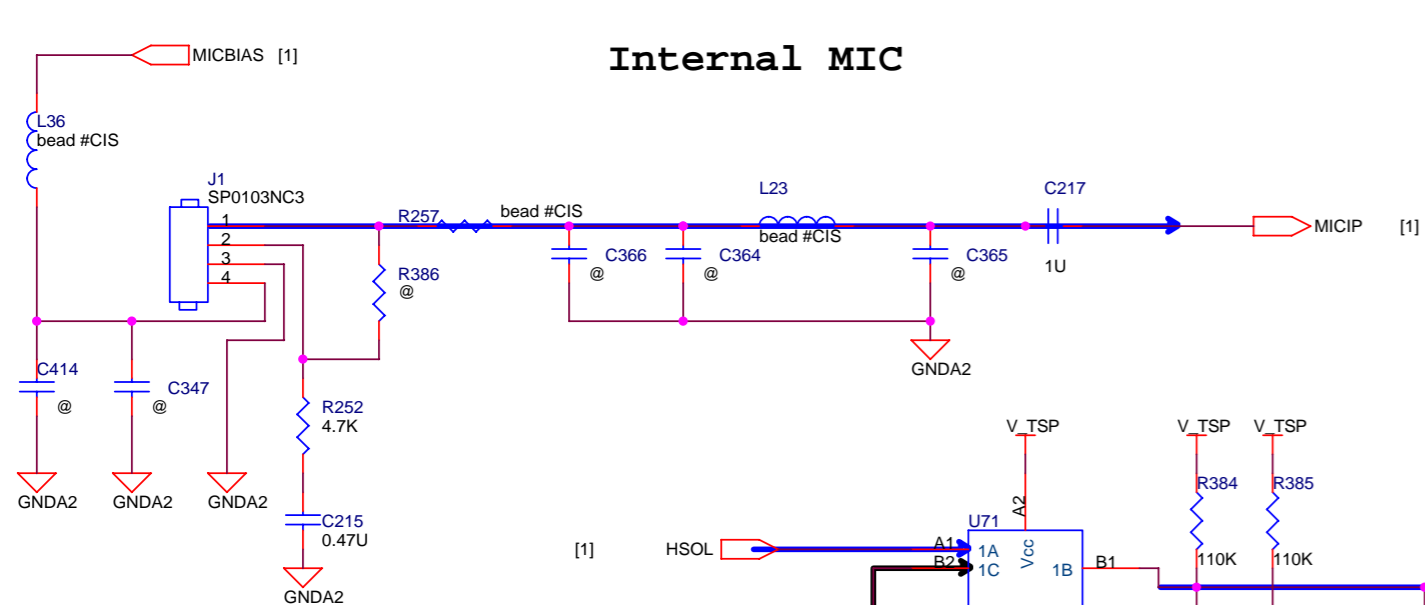

4 Rings PhoneJack

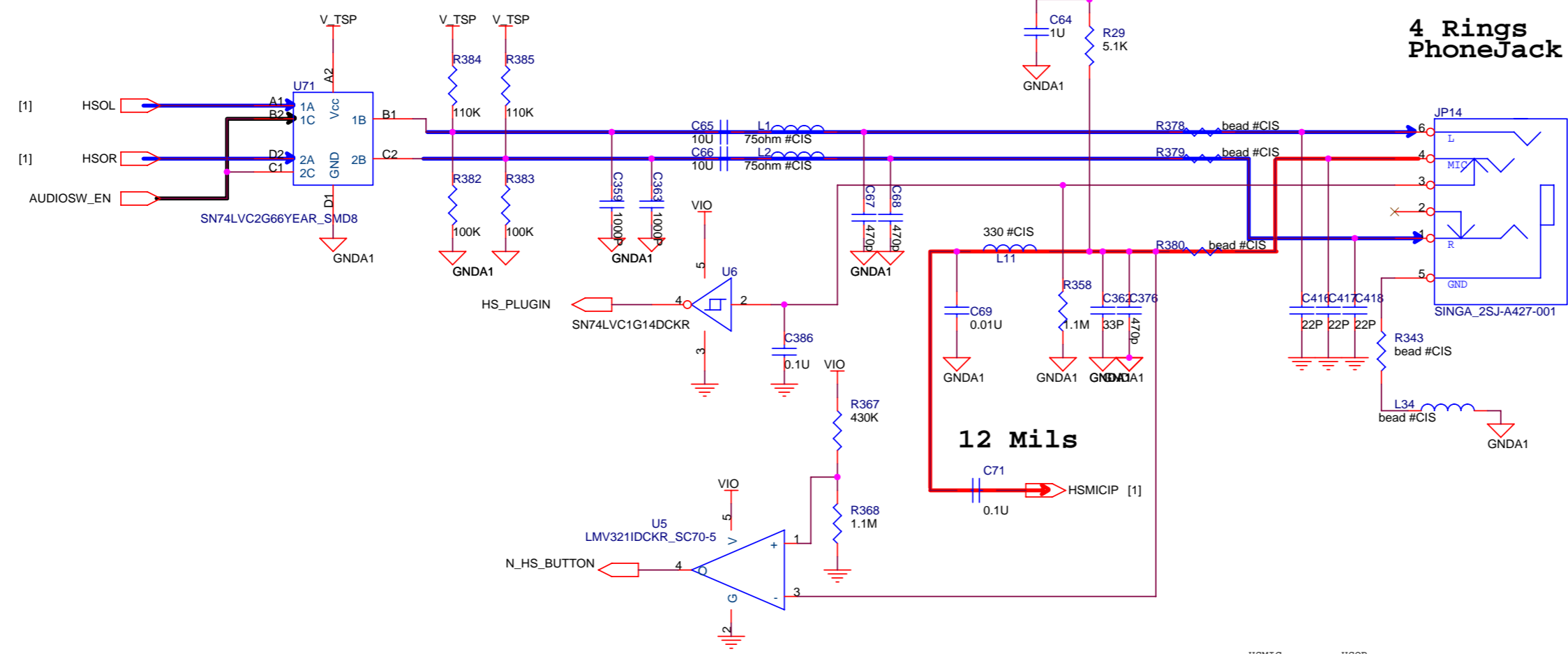

12 Mils

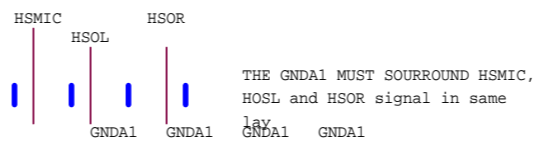

**TP167, TP168
TP161, TP162
For RF Calibration**

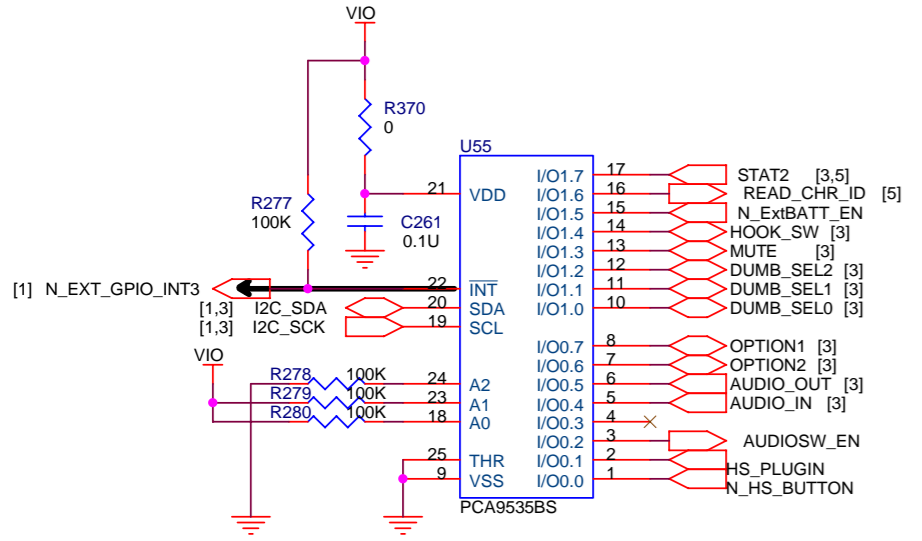
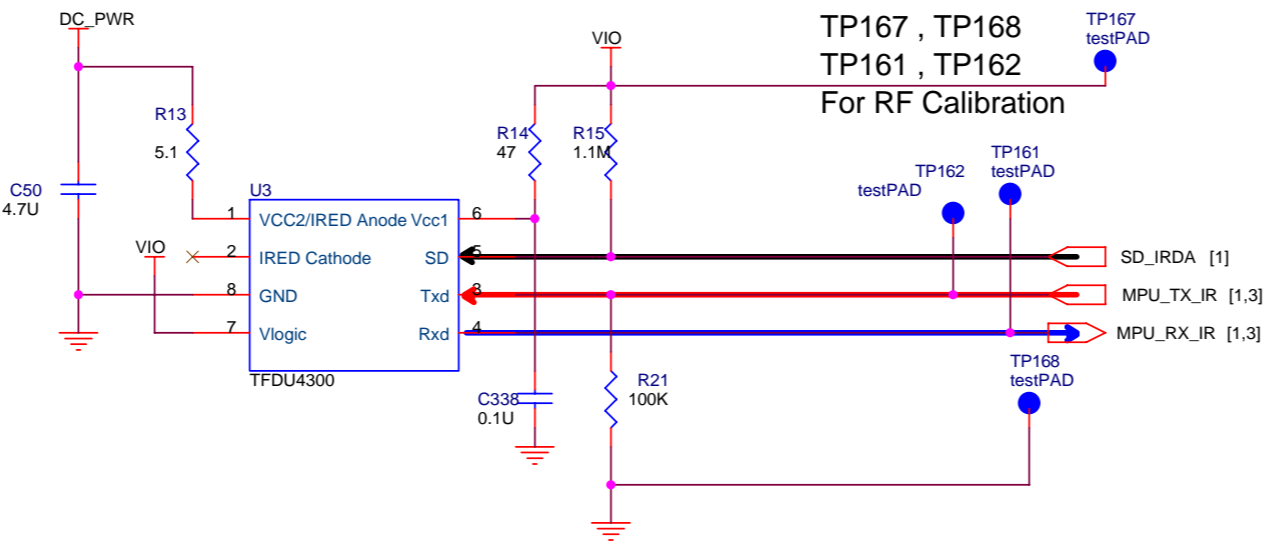

Charger Circuit

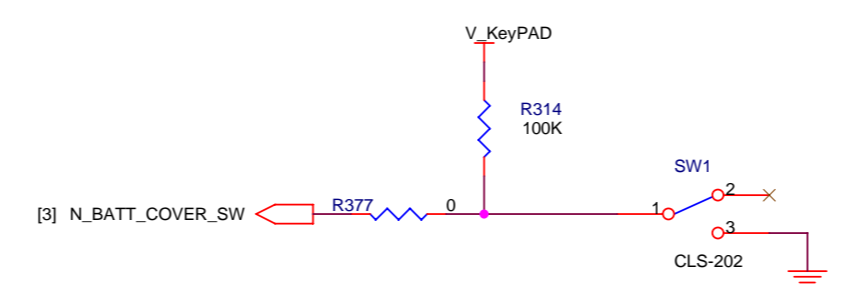
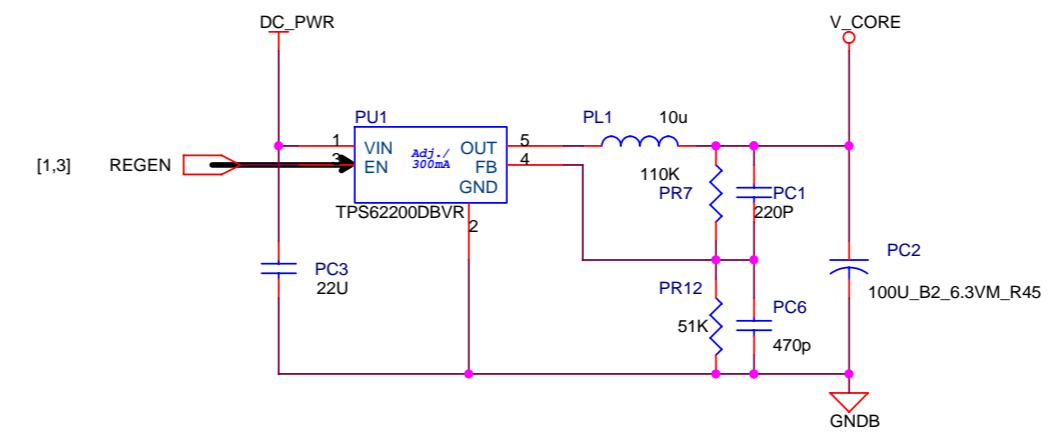
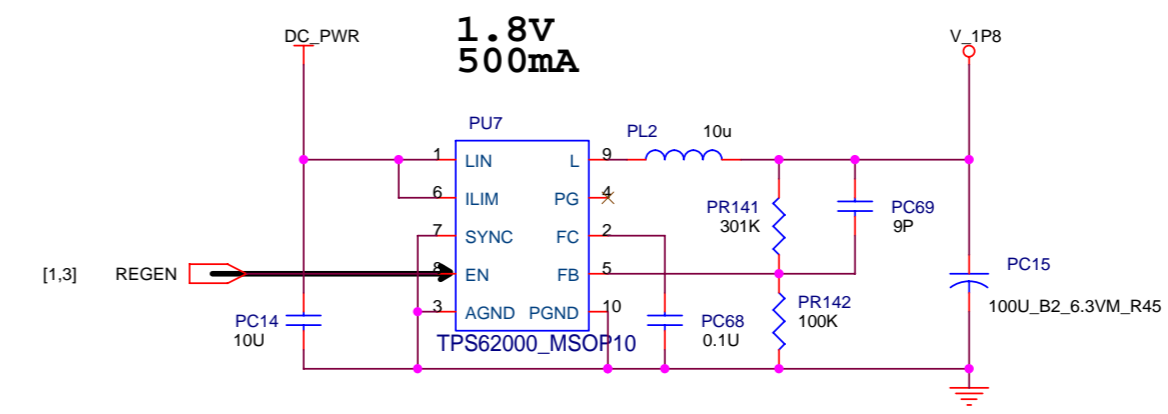
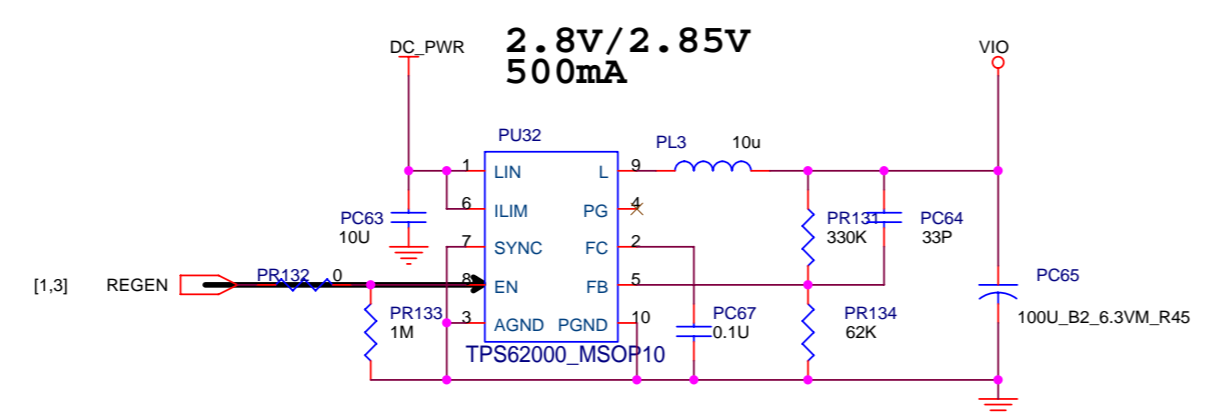
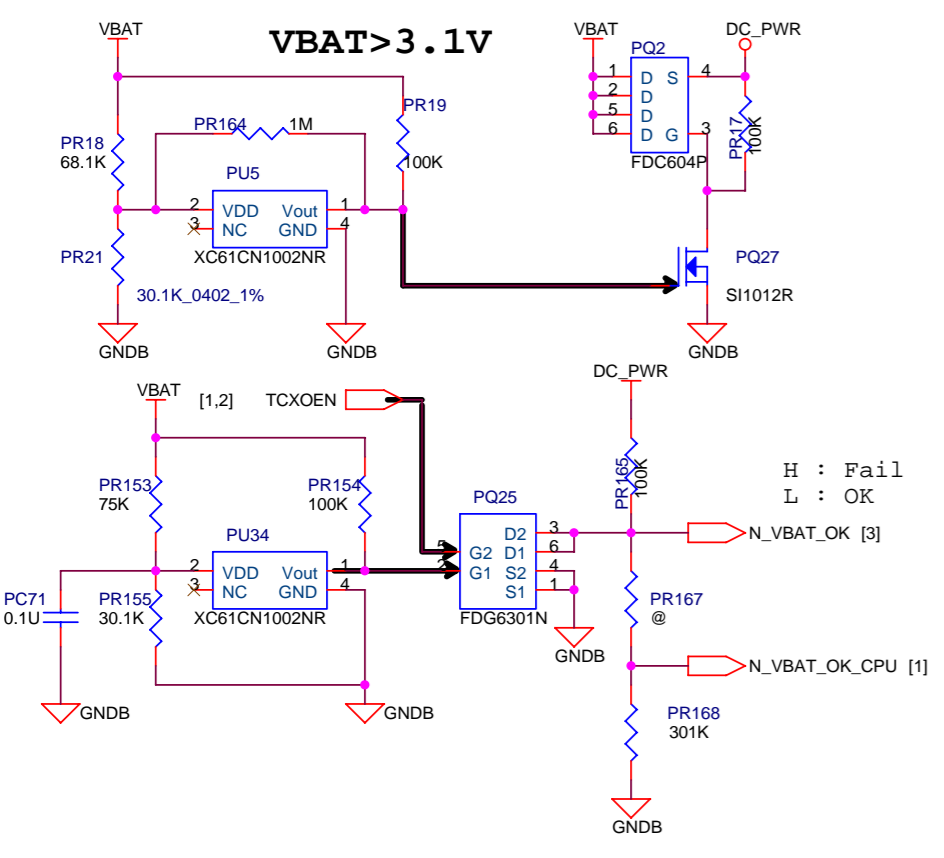
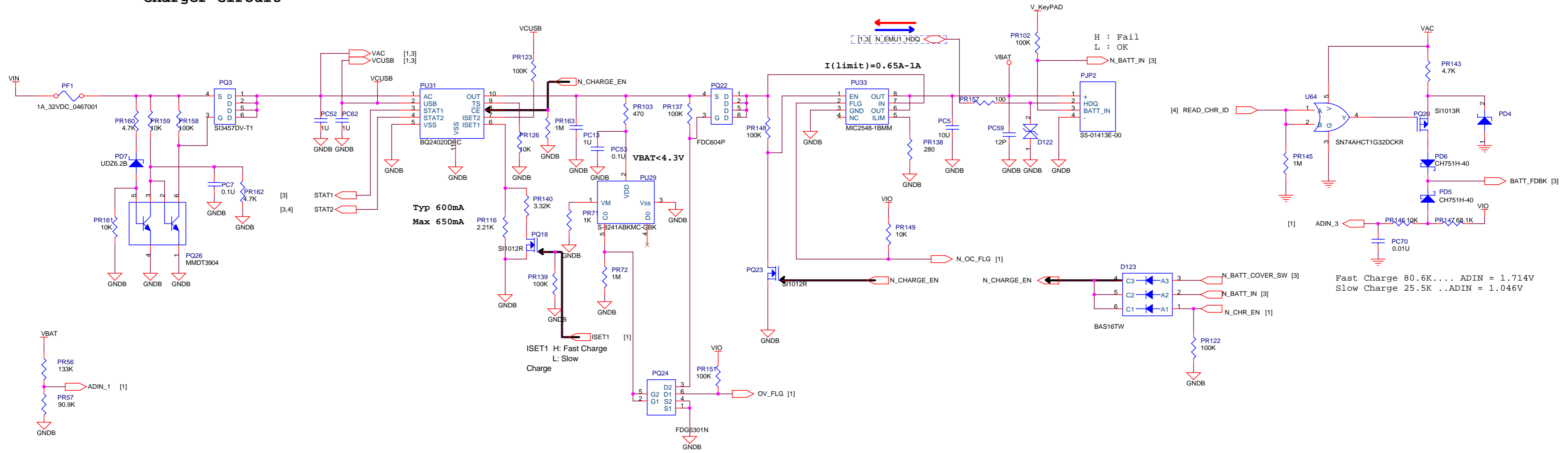

When DC_PWR = 4.2V ---- 2.887
When DC_PWR = 3.1V ---- 2.13V