



MOTOROLA

Level 2 Service Manual

6809497A97-O

Q

Digital Wireless Telephone



CDMA 800/1900 MHz, CDMA 1X/EV-DO

MOTOROLA and the Stylized M Logo are registered in the US Patent & Trademark Office.
All other product or service names are the property of their respective owners.

© Motorola, Inc. 2006.
All rights reserved.

Mobile Devices Business,
Sawgrass International Concourse
789 International Parkway
Room S2C
Sunrise, FL 33325-6220

Contents

Introduction	4
Product Identification	4
Product Names	4
Regulatory Agency Compliance	4
Computer Program Copyrights	5
About this Service Manual	5
Warranty Service Policy	6
Parts Replacement	7
Specifications	8
Product Overview	9
Features	9
General Operation	11
Controls, Indicators, and Input/Output (I/O) Connectors	11
Battery Function	15
Operation	16
Tools and Test Equipment	17
Disassembly	18
Removing the Battery Door	19
Removing and Replacing the Battery	20
Removing and Replacing the Rear Housing	21
Removing the Motor/Vibrator Assembly	23
Removing and Replacing the Antenna	24
Removing the Daughter Board	25
Removing the Camera Assembly	26
Removing and Replacing the Speaker Carrier	27
Removing and Replacing the Main Board	28
Removing and Replacing the Keyboard	30
Removing the Display Assembly	36
Removing and Replacing the Keypad	38
Phone Identification	39
Personality Transfer	39
Identification	39
Troubleshooting	40
Programming: Software Upgrade and Flexing	41
Exploded View Diagram	42
Exploded View Parts List	43
Accessories	44

Introduction

Motorola® Inc. maintains a worldwide organization that is dedicated to provide responsive, full-service customer support. Motorola products are serviced by an international network of company-operated product-care centers as well as authorized independent service firms.

Available on a contract basis, Motorola Inc. offers comprehensive maintenance and installation programs that enable customers to meet requirements for reliable, continuous communications.

To learn more about the wide range of Motorola service programs, contact your local Motorola products representative or the nearest Customer Service Manager.

Product Identification

Motorola products are identified by the model number on the housing. Use the entire model number when inquiring about the product. Numbers are also assigned to chassis and kits. Use these numbers when requesting information or ordering replacement parts.

Product Names

Product names are listed on the front cover. Product names are subject to change without notice. Some product names, as well as some frequency bands, are available only in certain markets.

Regulatory Agency Compliance

This device complies with Part 15 of the FCC Rules. Operation is subject to the following conditions:

- This device may not cause any harmful interference
- This device must accept interference received, including interference that may cause undesired operation

This class B device also complies with all requirements of the Canadian Interference-Causing Equipment Regulations (ICES-003).

Cet appareil numérique de la classe B respecte toutes les exigences du Règlement sur le matériel brouilleur du Canada.

Computer Program Copyrights

The Motorola products described in this manual may include Motorola computer programs stored in semiconductor memories or other media that are copyrighted with all rights reserved worldwide to Motorola. Laws in the United States and other countries preserve for Motorola, Inc. certain exclusive rights to the copyrighted computer programs, including the exclusive right to copy, reproduce, modify, decompile, disassemble, and reverse-engineer the Motorola computer programs in any manner or form without Motorola's prior written consent. Furthermore, the purchase of Motorola products shall not be deemed to grant either directly or by implication, estoppel, or otherwise, any license or rights under the copyrights, patents, or patent applications of Motorola, except for a nonexclusive license to use the Motorola product and the Motorola computer programs with the Motorola product.

About this Service Manual

Using this service manual and the suggestions contained in it assures proper installation, operation, and maintenance. Refer questions about this manual to the nearest Customer Service Manager.

Audience

This service manual aids service personnel in testing and repairing Q telephones. Service personnel should be familiar with electronic assembly, testing, and troubleshooting methods, and with the operation and use of associated test equipment.

Use of this manual assures proper installation, operation, and maintenance of Motorola products and equipment. It contains all service information required for the equipment described and is current as of the printing date.

Scope

This manual provides basic information relating to Q telephones, and provides procedures and processes for repairing the units at Level 1 and 2 service centers including:

- Unit swap out
- Repairing of mechanical faults
- Basic modular troubleshooting
- Testing and verification of unit functionality
- Initiate warranty claims and send faulty modules to Level 3 or 4 repair centers

Conventions

The following special characters and typefaces are used in this manual to emphasize certain types of information.



Note: Emphasizes additional information pertinent to the subject matter.



Caution: Emphasizes information about actions that may result in equipment damage.



Warning: Emphasizes information about actions that may result in personal injury.



Keys to be pressed are represented graphically. For example, instead of “Press the Menu Key”, you will see “Press ”.

Information from a screen is shown in text as similar as possible to what displays on the screen. For example, ALERTS.

Information that you need to type is printed in **boldface type**.

Warranty Service Policy

The product is sold with the standard 12-month warranty terms and conditions. Accidental damage, misuse, and extended warranties offered by retailers are not supported under warranty. Non warranty repairs are available at agreed fixed repair prices.

Out-of-Box Failure Policy

The standard out of box failure criteria applies. Customer units that fail very early on after the date of sale, are to be returned to Manufacturing for root cause analysis, to guard against epidemic criteria. Manufacturing will bear the costs of early life failure.

Product Support

Customer's original units will be repaired but not refurbished as standard. Appointed Motorola Service Hubs will perform warranty and non-warranty field service for level 2 (assemblies) and level 3 (limited PCB component). The Motorola High Technology Centers will perform level 4 (full component) repairs.

Customer Support

Customer support is available through dedicated Call Centers and in-country help desks. Product Service training is available through the local Motorola Support Center.

Parts Replacement

When ordering replacement parts or equipment, include the Motorola part number and description used in the service manual or supplement.

When the Motorola part number of a component is not known, use the product model number or other related major assembly along with a description of the related major assembly and of the component in question.

In the U.S.A., to contact Motorola, Inc. on your TTY, call: 800-793-7834

Accessories and Aftermarket Division (AAD)

Order replacement parts, test equipment, and manuals from AAD.

U.S.A.

Phone: 800-422-4210

FAX: 800-622-6210

Website: <http://businessonline.motorola.com>

Outside U.S.A.

Phone: 847-538-8023

FAX: 847-576-3023

EMEA

Phone: +49 461 803 1404

Website: <http://emeaonline.motorola.com>

Asia

Phone: +65 648 62995

Website: <http://asiaonline.motorola.com>

Specifications

General Function	Specification
Frequency Range 1900 MHz PCS	1931.250 -1988.750 MHz Rx 1851.250 -1908.750 MHz Tx
Frequency Range 800 MHz CDMA	869.70 - 893.31 Rx 824.70 - 848.31 Tx
Channel Spacing	50 kHz PCS 30 kHz CDMA
Channels	1150 PCS 788 CDMA 800
Modulation	1M25D1W (1.25 MHz bandwidth) CDMA 3G1XRTT (1.25 MHz bandwidth) CDMA-1X
Duplex Spacing	80 MHz PCS 45 MHz CDMA 800
Frequency Stability	± 150 Hz (CDMA)
Power Supply	3.6V Li Ion 1130 mAh battery
Average Transmit Current	310 mA at +13 dBm)
Average Stand-by Current	3.40 mA
Dimensions (WHD) (with 1130 mAh Li Ion battery)	64mm x 116mm x 11.5mm 2.5 in. x 4.5 in. x 0.4 in.
Size (Volume)	80 cc (4.8 in. ³) without antenna
Weight	≤115g (4.65 oz) with battery
Temperature Range	-30° C to +60° C (-22° F to +140° F)
Humidity	80% Relative Humidity at 50° C (122° F)
Battery Life, 1130 mAh Li Ion Battery	Up to 180 minutes digital talk time (IS 95 A/B) Up to 250 hours (IS 95 A/B) standby time Up to 350 hours (IS 2000) standby time
	All talk and standby times are approximate and depend on network configuration, signal strength, and features selected.

Transmitter Function	Specification
RF Power Output	0.20 watts -23 dBm into 50 ohms (CDMA nominal)
Input/Output Impedance	50 ohms (nominal)
Transmit Audio Response	6 dBm/octave pre-emphasis
Modulation	1M25DIW (1.25 MHz bandwidth) CDMA
CDMA Transmit Waveform Quality (Rho)	0.94

Receiver Function	Specification
Receive Sensitivity	-104 dBm (CDMA, 0.5% Static FER) 0.5% or less
Audio Distortion	Less than 5% at 1004 Hz, +/- 8 kHz peak frequency deviation (transmit and receive)
Adjacent and Alternate Channel Desensitization	3% BER max at 107 dBm signal; -94 dBm/30 kHz, -65 dBm/60 kHz

Product Overview

Motorola Q mobile telephones feature Code Division Multiple Access (CDMA) technology. Q also supports EVDO a wireless radio broadband data standard adopted by many CDMA mobile phone service providers. Compared to 1xRTT (CDMA2000 1x) networks currently being used by operators, 1xEV-DO is significantly faster, providing mobile devices with air interface speeds of up to 2.4576 Mb/s with Rev. 0 and up to 3.1 Mb/s with Rev. A. Only terminals with 1xEV-DO chipsets can take advantage of the higher speeds.

The Q uses the Microsoft Windows Mobile operating system. Windows Mobile is a compact operating system for mobile devices based on the Microsoft Win32 API.

The Q mobile device provides Short Message Service (SMS) text messaging, and includes clock, alarm, datebook, calculator, and caller profiling personal management tools. The Q also has a built in 1.3 Megapixel camera with 6X digital zoom, Bluetooth wireless connectivity. The phone provides 32 Embedded ring tones including VibraCall vibrating alert and 32 Downloadable/Customizable iMelody ring tones. The phone also contains a Secure Data (SD) removable memory expansion slot. The Q is a dual band phone that allows roaming within the CDMA 800 and 1900 MHz bands.

The Q CDMA phone consists of a main housing assembly that contains the battery, battery cover, accessory connector, main circuit board, chassis, keypad, and internal antenna. The main display, speaker, control keys, and a QWERTY keyboard are located on the front of the device. The camera, battery compartment, and rf connectors are located at the rear of the device.

The main circuit board contains the Receiver, Transmitter, Synthesizer and Control Logic Circuitry which together comprise the dual band phone electronics.

The main display is a 2.4" 320 x 240 65k TFT LCD. The camera is a 1.3 mega pixel, with 6X digital zoom.

The telephones are made of polycarbonate plastic. The 1130 mAh Lithium Ion (Li Ion) battery provides up to 178 minutes of talk time in CDMA mode with up to 141 hours of standby time¹.

Features

Q telephones use advanced, self-contained, sealed, custom integrated circuits to perform the complex functions required for CDMA communication. Aside from the space and weight advantage, microcircuits enhance basic reliability, simplify maintenance, and provide a wide variety of operational functions.

Features available in this product include:

- Thinnest Converged Device on the market – 11.5mm
- Windows Mobile™ 5.0 software with email, calendar, contacts and tasks
- Enabled for leading corporate email solutions
- Receive and view documents, spreadsheets, presentations and more
- Optimized QWERTY keyboard
- Video capture and playback
- Connectivity via ActiveSync®, AirSync®, Bluetooth™ wireless technology and IrDA

1. All talk and standby times are approximate and depend on network configuration, signal strength, and features selected. Standby times are quoted as a range from DRX=2 to DRX=9. Talk times are quoted as a range from DTX off to DTX on.

- 1.3 mega pixel camera
- Multi-Media Messaging (MMS)
- Dual stereo quality speakers
- Audio formats supported: iMelody, MIDI, MP3, AAC, WAV, WMA, WAX, QCELP
- Image formats supported: GIF87a, GIF89a, JPEG, WBMP, BMP, PNG
- Video formats supported: H.263, MPEG-4, GSM-AMR, AAC, WMV
- Mini-SD removable memory
- Large, high-resolution display (320 x 240 pixels, 65K TFT)
- Display: 2.4" 320x240 65K TFT

Personal Information Management

The Q leverages Microsoft's Windows Mobile software and is among the first devices to run on the new Windows Mobile 5.0 platform which delivers scalable and cost-effective mobile messaging support with Exchange 2003 out of the box.

Enabled for leading corporate email solutions, the Moto Q can meet the diverse needs of the enterprise.

The user can receive and view documents, spreadsheets, presentations and more.

General Operation

Controls, Indicators, and Input/Output (I/O) Connectors

The Q telephones' controls are on the front and sides of the device, and on the keyboard as shown in Figures 1 and 2.

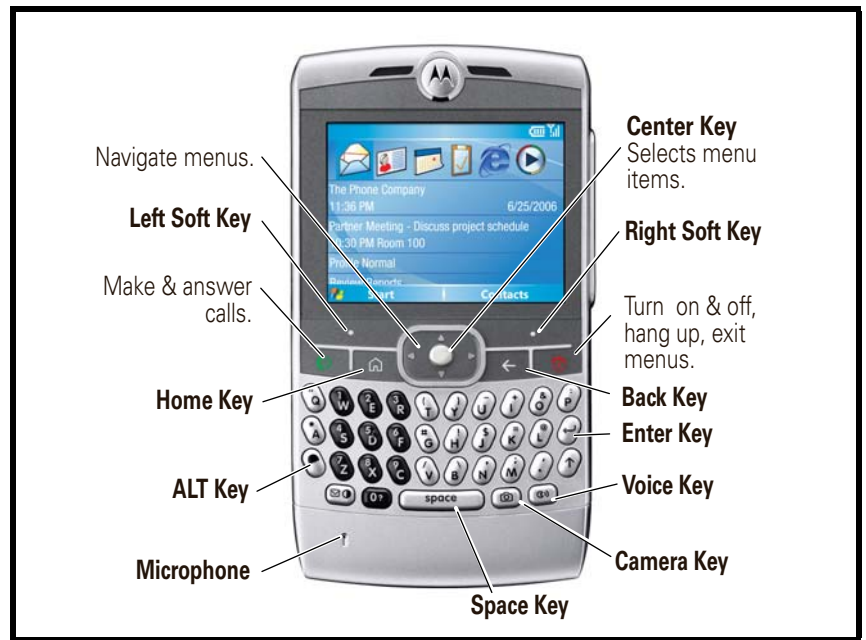
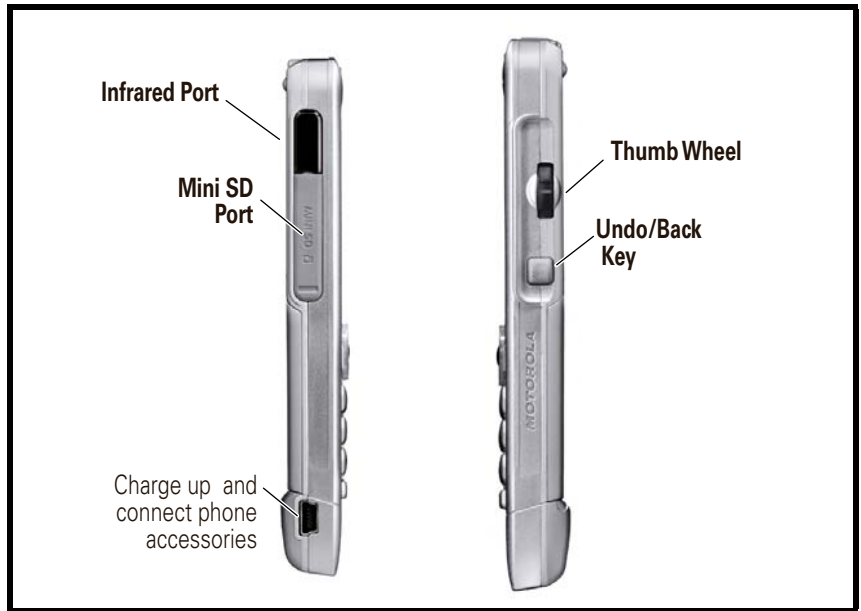

Figure 1. Controls and Indicators Locations, Front

0502500



0601510

Figure 2. Controls and Indicator Locations, Left and Right Side



060xxx0

Figure 3. Controls and Indicator Locations, Back Side

Menu Navigation

Q telephones have a simple icon and GUI. The phone also features a customizable Start menu accessed by pressing the Start key.

A 5-way navigation key allows you to move easily through menus. Figure 4 provides a view of the Home screen display.

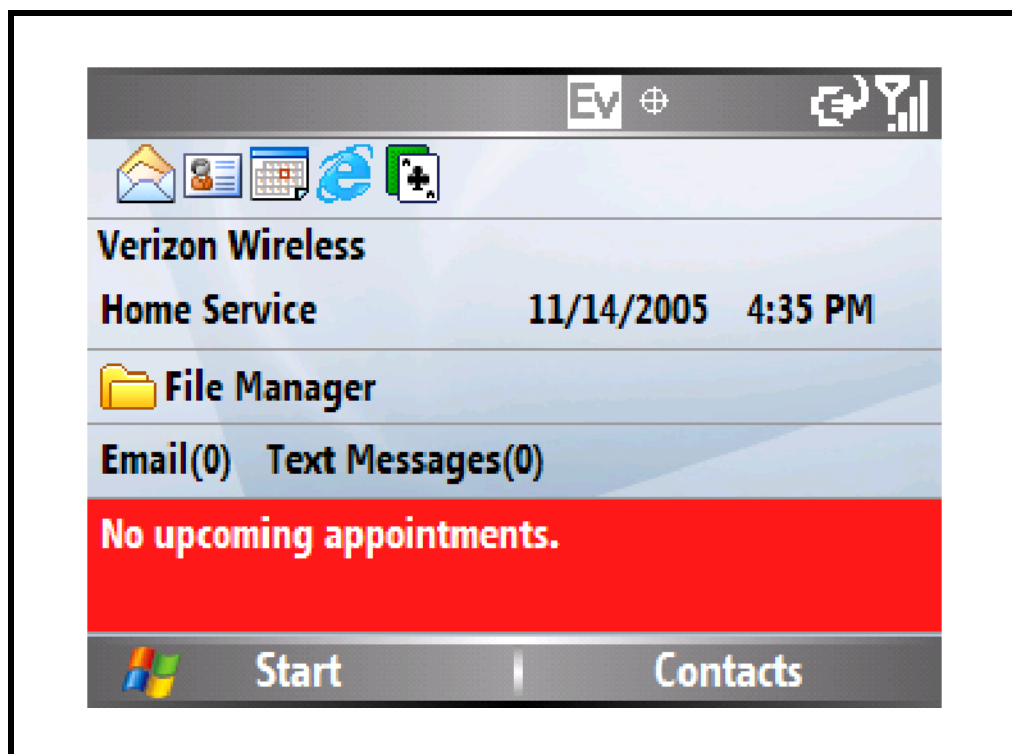

0601700

Figure 4. Home Screen Display

Status Icons

The main display provides constant graphical representations of battery capacity and signal strength, as well as the real-time clock. The Q user guide provides more information about icons shown on the main display.



Whether a phone displays all indicators depends on the programming and services to which the user subscribes.

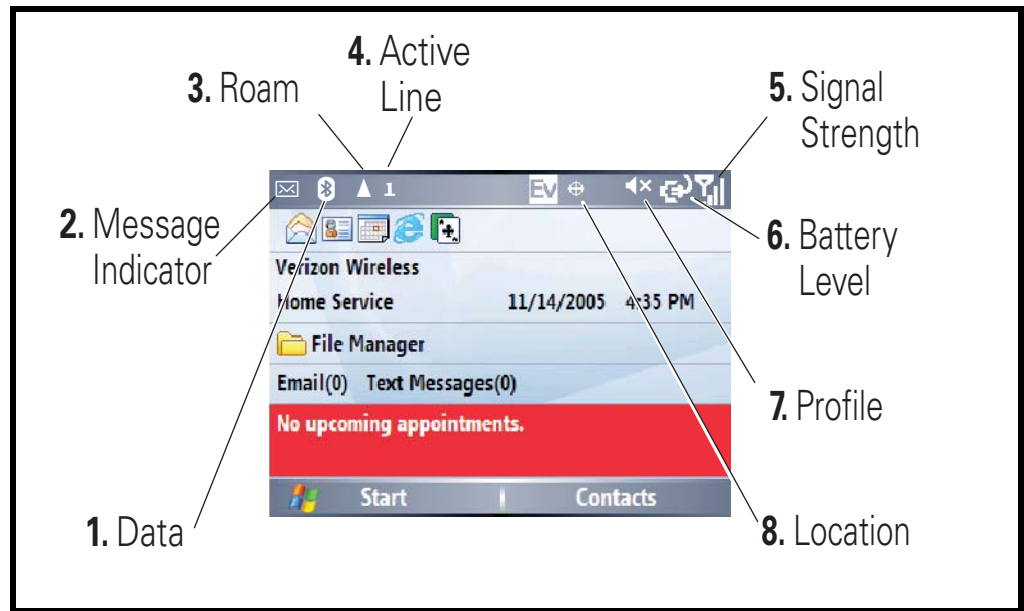

Figure 5. Home Screen Status Icons

1 Data Indicator Shows connection status. Other indicators can include:



 = secure data transfer  = Bluetooth® wireless connection





2 Message Indicator Shows when you receive a new message. Indicators can include:



 = new e-mail or text message  = voicemail message

3 Roam Indicator The roam indicator shows when your phone is seeking or using a network outside your home network. Other indicators can include:

 = 2G home  = roaming unavailable

4 Active Line Indicator Shows  to indicate an active call, or  to indicate when call forwarding is on. Indicators can include:

 = line 1 active  = line 2 active
 = line 1 active, call forward on
 = line 2 active, call forward on

5 Signal Strength Indicator Vertical bars show the strength of the network connection. You can't make or receive calls when  or  displays.

6 Battery Charge Indicator Vertical bars show the battery charge level. Recharge the battery when your phone shows **Low Battery**.

7 Profile Indicator Shows the call alert (ring) setting. When the profile is normal, outdoor, or automatic, no indicator is displayed.

- ☎ = meeting 📞 = speakerphone
- 🚗 = car (no icon) = normal
- 🔇 = silent (no icon) = outdoor
- 🎧 = headset (no icon) = automatic

8 Location Indicator Shows when your phone can send location information 📍 or not 📍.

Battery Function

Battery Charge Indicator

The telephone displays a battery charge indicator icon in the idle screen to indicate the battery charge level. The gauge shows four levels: 100%, 66%, 33%, and Low Battery.

Battery Removal

Removing the battery causes the device to shut down immediately and lose any pending work (partially entered phone book entries or outgoing messages, for example). If battery is removed before the unit is fully powered down, the display will not display properly until the unit is powered down correctly and then repowered up. (Snowy screen).



All batteries can cause property damage and / or bodily injury such as burns if a conductive material, such as jewelry, keys, or beaded chains touch exposed terminals. The conductive material may complete an electrical circuit (short circuit) and become quite hot. Exercise care in handling any charged battery, particularly when placing it inside a pocket, purse, or other container with metal objects.



If the battery is removed while receiving a message, the message is lost.



To ensure proper memory retention, turn the phone OFF before removing the battery. Immediately replace the old battery with a fresh battery.

Operation

For detailed operating instructions, refer to the appropriate User Guide listed in the Related Publications section toward the end of this manual.

Tools and Test Equipment

The following table lists tools and test equipment recommended for disassembly and reassembly of Q telephones. Use either the listed items or equivalents.

Table 1. General Test Equipment and Tools

Motorola Part Number ¹	Description	Application
RSX4043-A	Torque Driver	Used to remove and replace screws
—	Torque Driver Bit T-6, Apex 440-6 Torx or equivalent. Torque setting is 1.25 in-lbs or 14 Ncm	Used with torque driver
See Table 7	Rapid Charger	Used to charge battery and power phone
0180386A82	Antistatic Mat Kit (includes 66-80387A95 antistatic mat, 66-80334B36 ground cord, and 42-80385A59 wrist band)	Provides protection from damage to device caused by electrostatic discharge (ESD)
19501980 (AMS) ²	Generic Press Tool	
0-00-00-40849 (AMS) ²	keyboard adapter	Used to install keyboard
0-00-00-30005 (AMS) ²	Disassembly tool, plastic with flat and pointed ends (manual opening tool)	Used during assembly/disassembly of phone

1. To order in North America, contact Motorola Aftermarket and Accessories Division (AAD) at (800) 422-4210 or FAX (800) 622-6210; Internationally, AAD can be reached by calling (847) 538-8023 or by fax (847) 576-3023.

2. Not available from Motorola. To order, contact: AMS Software & Elektronik GmbH, c/o Holger Grube, Lise-Meitner-Straße 9 D-24941 Flensburg Tel.: +49-461-90398-0 Fax: +49-461-90398-50

Disassembly

The procedures in this section provide instructions for the disassembly of a Q telephone. Tools and equipment used for the phone are listed in Table 1, preceding.



Many of the integrated devices used in this phone are vulnerable to damage from electrostatic discharge (ESD). Ensure adequate static protection is in place when handling, shipping, and servicing the internal components of this equipment.



Avoid stressing the plastic in any way to avoid damage to either the plastic or internal components.

Removing the Battery Door

1. Ensure the phone is turned off.
2. Slide the battery cover latch as shown in Figure 6.
3. Gently lift the top end of the battery cover away from the phone.
4. Lift the battery cover away from the phone.

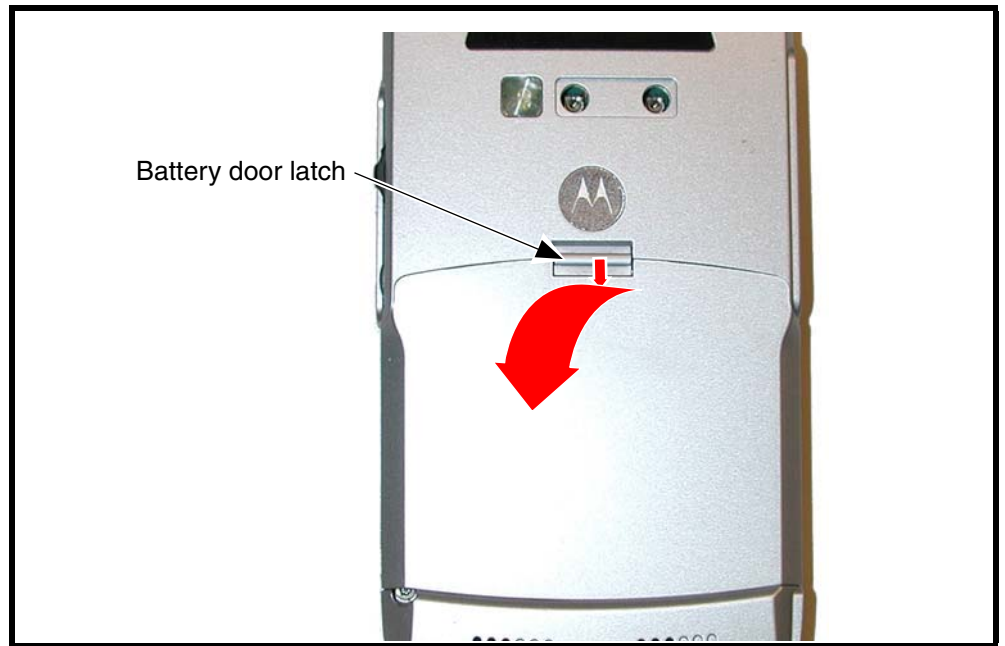

0601670

Figure 6. Removing the Battery Door

5. To replace, align the battery cover to the phone.
6. Insert the bottom end of the battery cover into the phone.
7. Lower the top end of the battery cover onto the phone until battery cover latch snaps into place.

Removing and Replacing the Battery



All batteries can cause property damage and / or bodily injury, such as burns if a conductive material, such as jewelry, keys, or beaded chains touch exposed terminals. The conductive material may complete an electrical circuit (short circuit) and become quite hot. Exercise care in handling any charged battery, particularly when placing it inside a pocket, purse, or other container with metal objects.

1. Ensure the phone is turned off.
2. Remove the battery cover as described in the procedures.
3. Lift up the edge of the battery near the side of the phone, as shown in Figure 7.
4. Lift the battery out of the phone.



0601730

Figure 7. Removing the Battery

5. To replace, align the battery with the battery compartment so the contacts on the battery match the battery contacts in the phone.
6. Insert the left edge of the battery into the battery compartment.
7. Lower the right edge of the battery into the battery compartment until the battery is completely seated.
8. Replace the battery door as described in the procedures.

Removing and Replacing the Rear Housing

1. Remove the battery door, and the battery as described in the procedures.
2. Use a T-6 driver to remove the four rear housing screws on the back of the phone (see Figure 8).

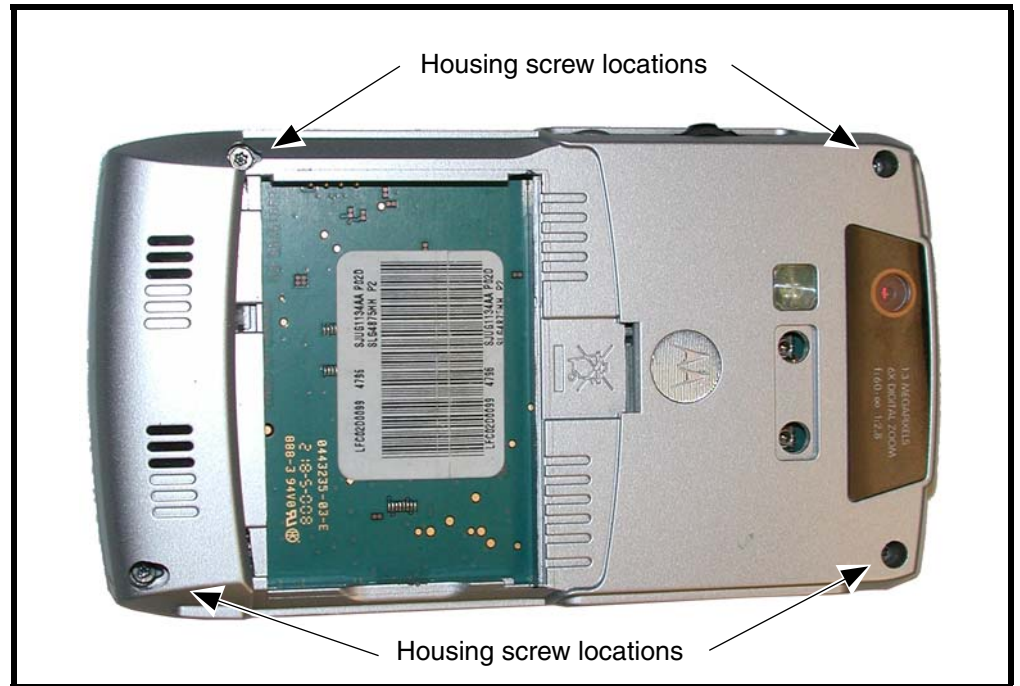

0601900

Figure 8. Removing the Rear Housing Screws

3. Insert the disassembly tool between the front and rear housings and rotate it at the places indicated (as shown in Figure 9) to release the housing snaps. Press on the front housing and then pull the front and rear housings apart.

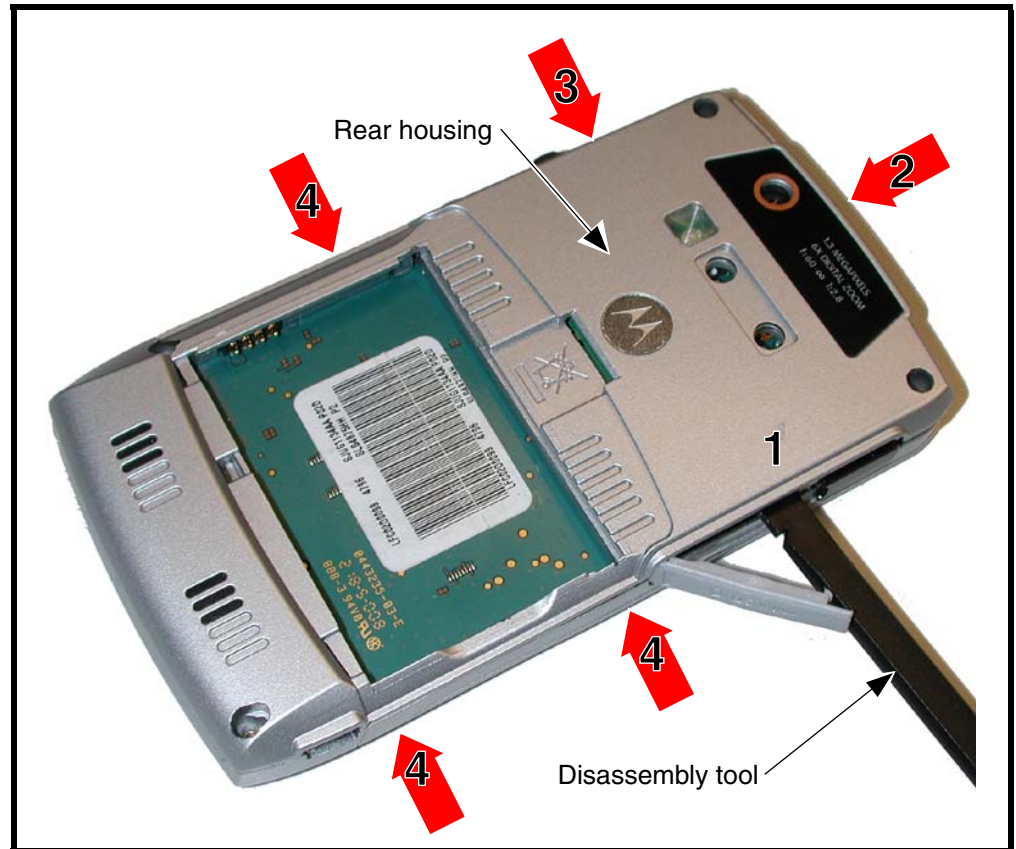
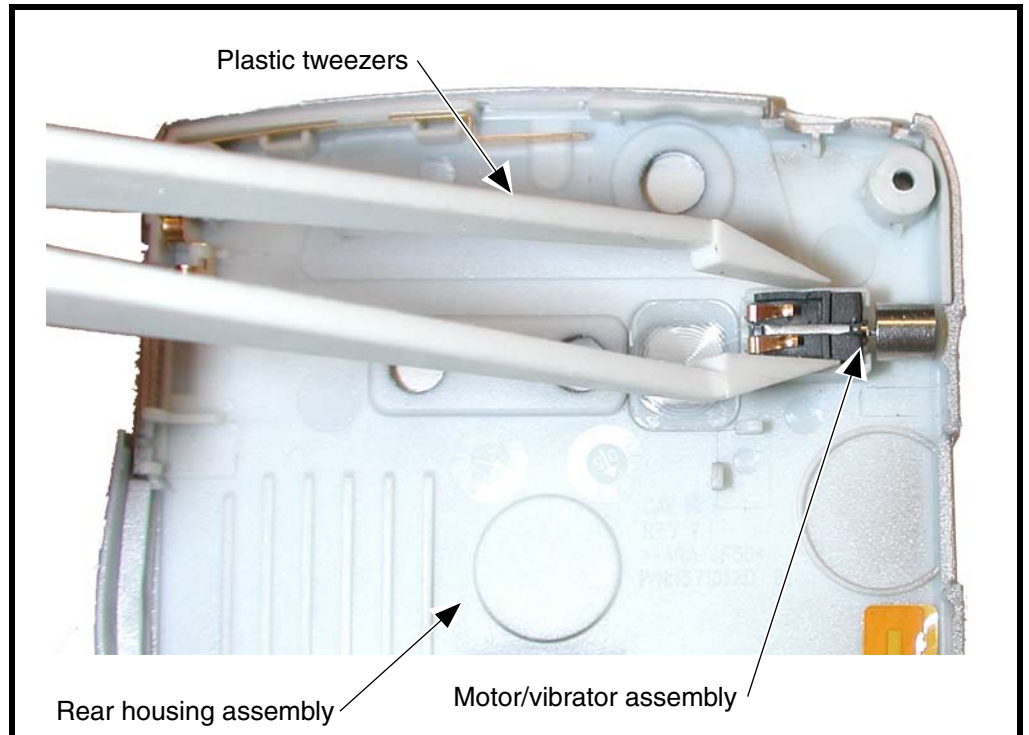

Figure 9. Removing the Rear Housing Latches

4. Lift the top end of the rear housing, and then the bottom end away from the phone.
5. To replace, align the rear housing to the phone.
6. Carefully press the rear housing onto the phone until all the housing snaps are fully engaged.
7. Insert 6 T6 screws into the rear housing assembly and tighten to 14 Ncm (1.25 inch-pounds).
8. Replace the battery and battery door as described in the procedures.

Removing the Motor/Vibrator Assembly

1. Remove the battery door, battery, and rear housing, as described in the procedures.
2. Use the plastic tweezers to lift the motor/vibrator assembly out of the rear housing (see Figure 10).



0603460

Figure 10. Removing the Motor/Vibrator Assembly

3. To replace, align the motor/vibrator assembly to its place in the rear housing assembly.
4. Carefully press the motor/vibrator assembly into position in the rear housing. Ensure the motor/vibrator shaft turns freely.
5. Replace the rear housing, battery, and battery door as described in the procedures.

Removing and Replacing the Antenna

1. Remove the battery cover, battery and rear housing as described in the procedures.
2. Insert one prong of the metal tweezers into the access slot to release the snap securing the antenna carrier to the main PC board.
3. Once the snap is released, lift the antenna carrier straight up and away from the phone. Avoid damage to the pogo pins (see Figure 11).

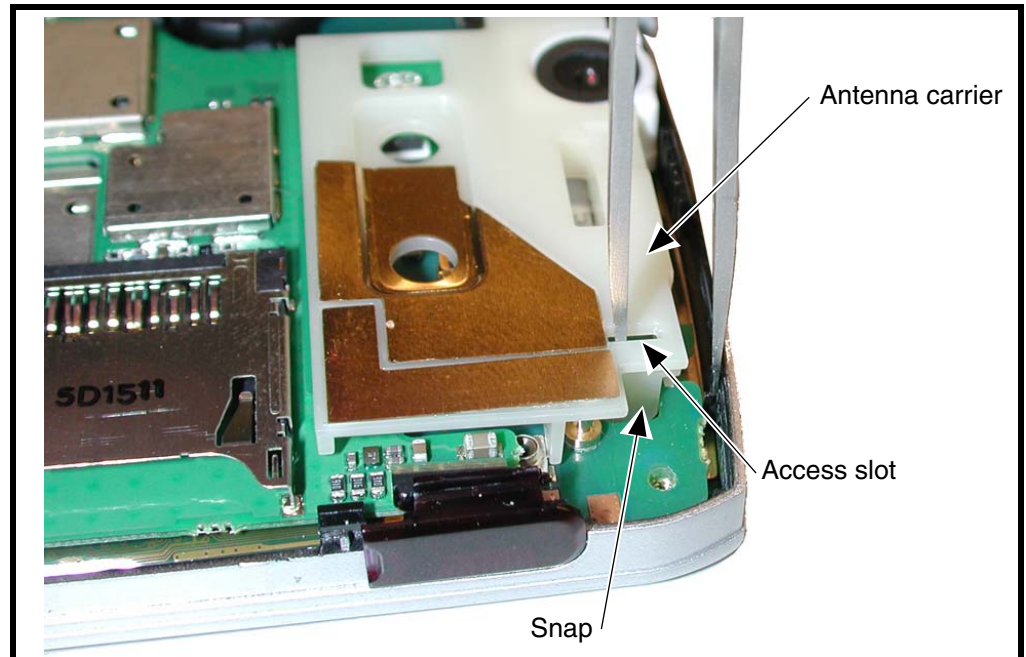

060200o

Figure 11. Removing the Antenna Carrier

4. To replace, align the antenna carrier to the phone.
5. Press the antenna carrier onto the main board until the snaps engage.
6. Replace the rear housing, battery, and battery cover as described in the procedures.

Removing the Daughter Board

1. Remove the battery door, battery, rear housing, and antenna as described in the procedures.
2. Insert the disassembly tool under the daughter board and rotate the disassembly tool to unseat the daughterboard from its connector on the main PC board (see Figure 9).

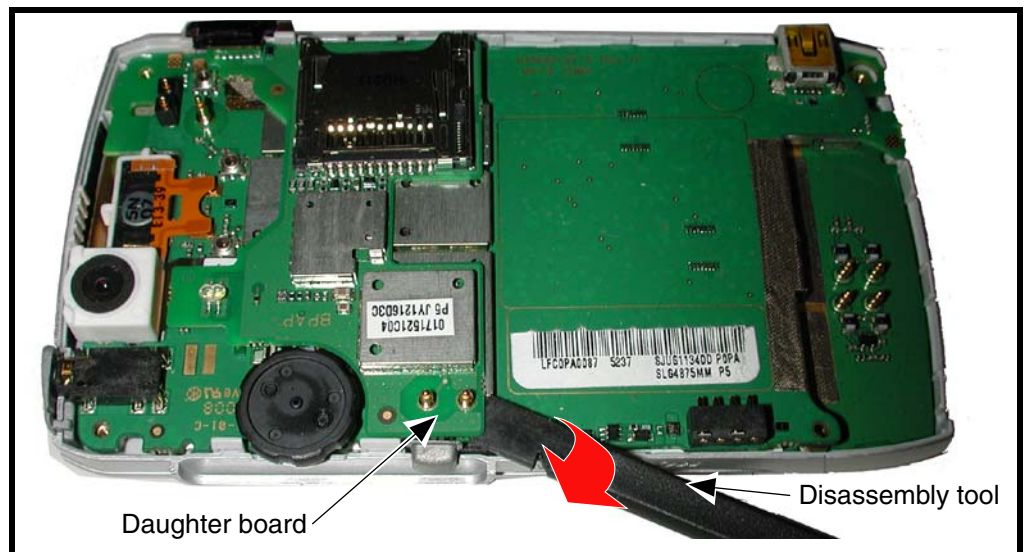

Figure 12. Removing the Daughter Board

060213o

3. Lift the daughter board away from the phone.
4. To replace, align the daughter board to the main PC board and then gently press the daughter board connector to fully seat the connector into the main board socket.
5. Replace the antenna, rear housing, battery and battery door as described in the procedures.

Removing and Replacing the Speaker Carrier

1. Remove the battery door, battery, and rear housing, as described in the procedures.
2. Use the disassembly tool to release the latches that secure the speaker.
3. Lift the speaker carrier up and out of the rear housing (see Figure 14).

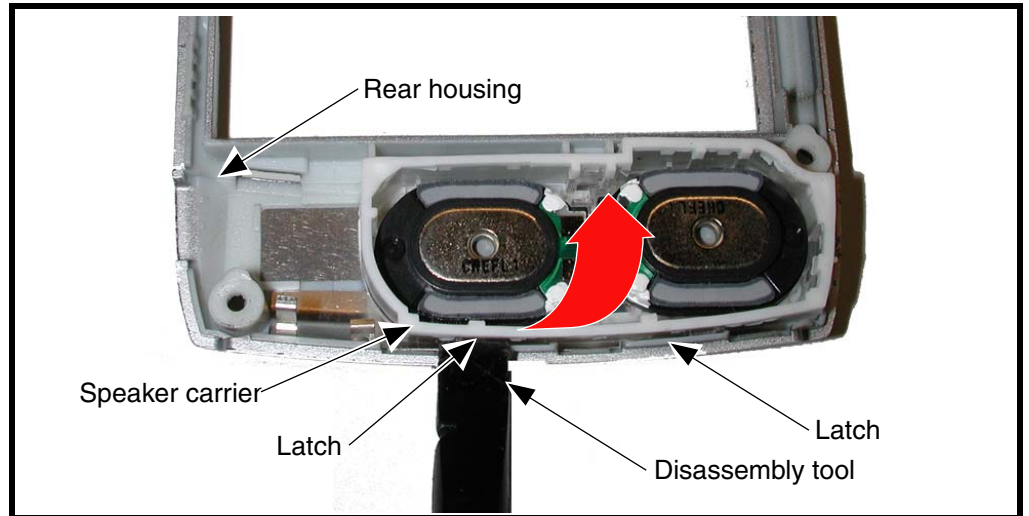

060217o

Figure 14. Removing the Speaker Carrier

4. To replace, align the speaker carrier to the rear housing and press into position so that latches secure the speaker carrier.
5. Replace the rear housing, battery and battery door as described in the procedures.

Removing and Replacing the Main Board

1. Remove the battery door, battery, rear housing, antenna, and daughter board as described in the procedures.



The flexible printed cable (FPC) (flex) is easily damaged. Exercise extreme care when handling.

2. Use the disassembly tool to unseat the display flex connector (See Figure 15).

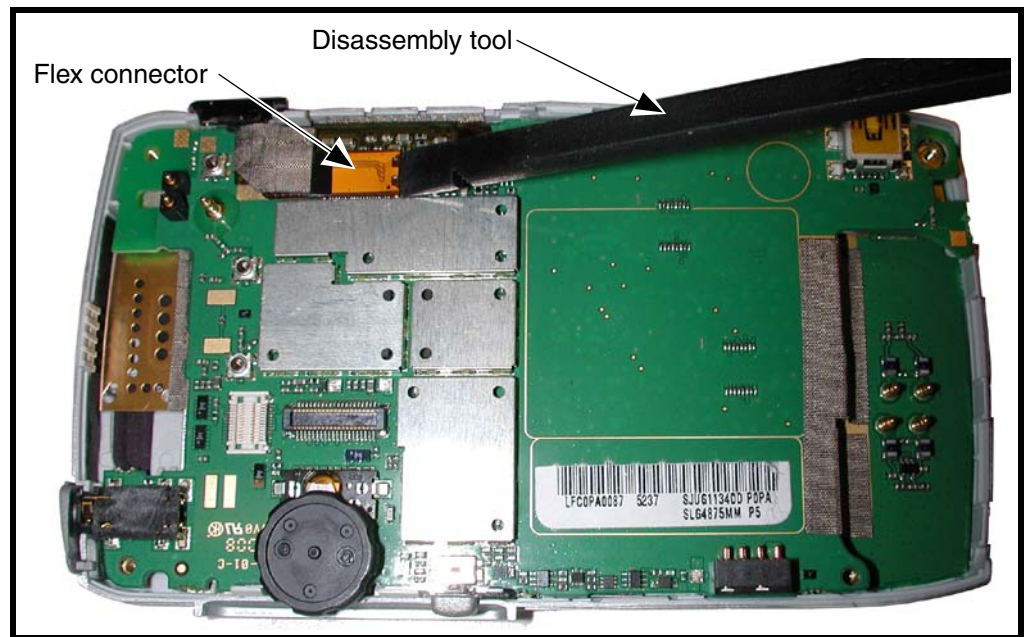

0602500

Figure 15. Removing the Display FLEX Connector

- Carefully remove the main board and keyboard out of the front housing.

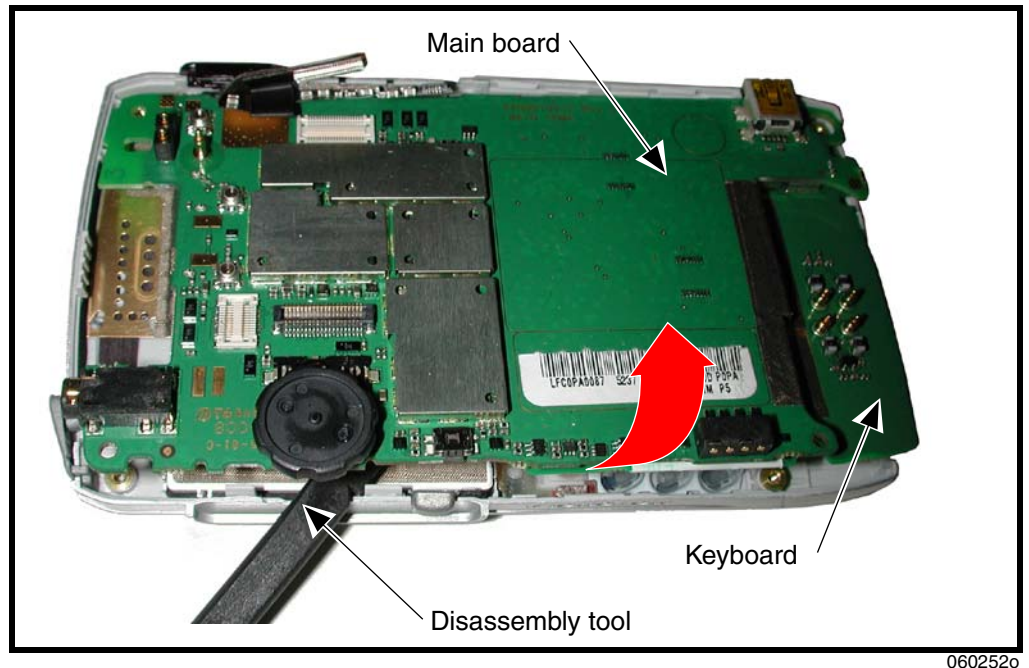

Figure 16. Removing the Main Board and Keyboard

060252o



This product contains static-sensitive devices. Use anti-static handling procedures to prevent electrostatic discharge (ESD) and component damage.

- To replace, align the main board and keyboard to the rear housing assembly and lower it into place on the rear housing.
- Press display flex onto transceiver board adhesive.
- Press display flex connector onto its socket.
- Replace the keyboard stiffener, speaker cover, keypad bezel, antenna, battery, and battery cover as described in the procedures.

Removing and Replacing the Keyboard

1. Remove the battery door, battery, rear housing, antenna, daughter board, and main board, and as described in the procedures.
2. Use the metal tweezers to remove the grounding gasket from the main board and keyboard (see Figure 17).

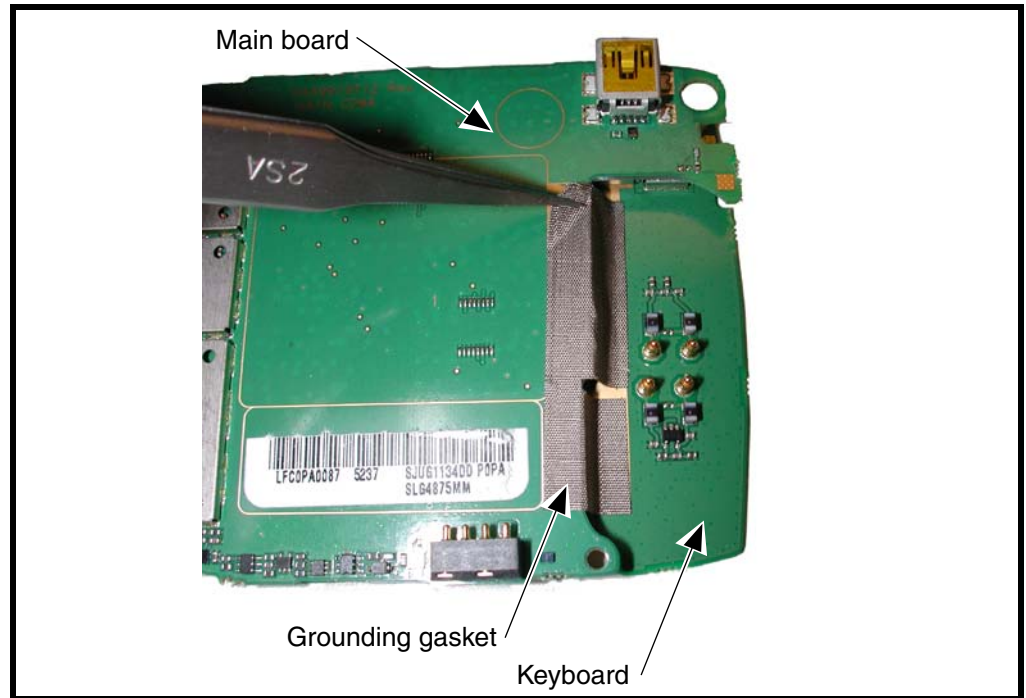
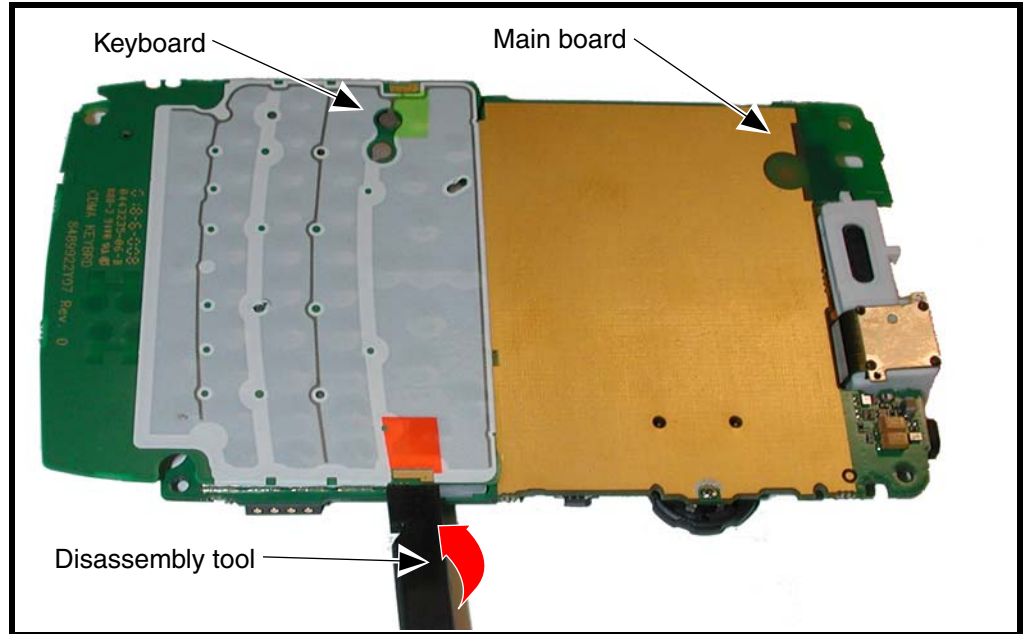

Figure 17. Removing the Grounding Gasket

3. Insert the disassembly tool under the top of keyboard and slowly slide it under the keyboard. Once it reaches the center of the board, twist until adhesive detaches. (see Figure 18).



0607910

Figure 18. Removing the Keyboard



This product contains static-sensitive devices. Use anti-static handling procedures to prevent electrostatic discharge (ESD) and component damage.

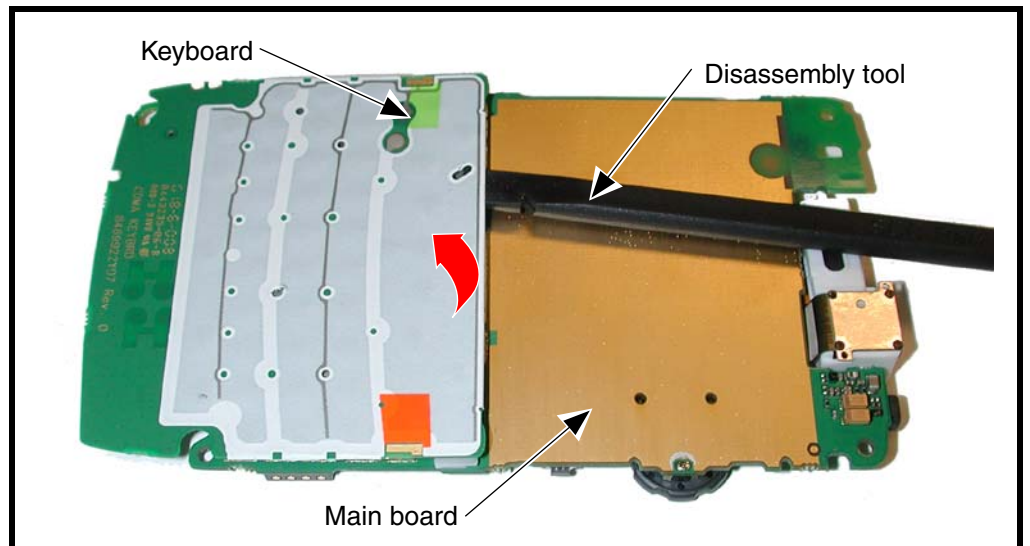

0607920

Figure 19. Removing the Keyboard

4. Remove adhesive from keyboard and main board and clean with isopropyl alcohol, if any residue remains. Add new adhesives to the keyboard before reattaching. Alignment and press fixtures must be used for reassembly.
5. To replace, attach keyboard and bootstrap to main board.
6. Remove liners from doubled sided adhesive on keyboard and place keyboard into alignment fixture.

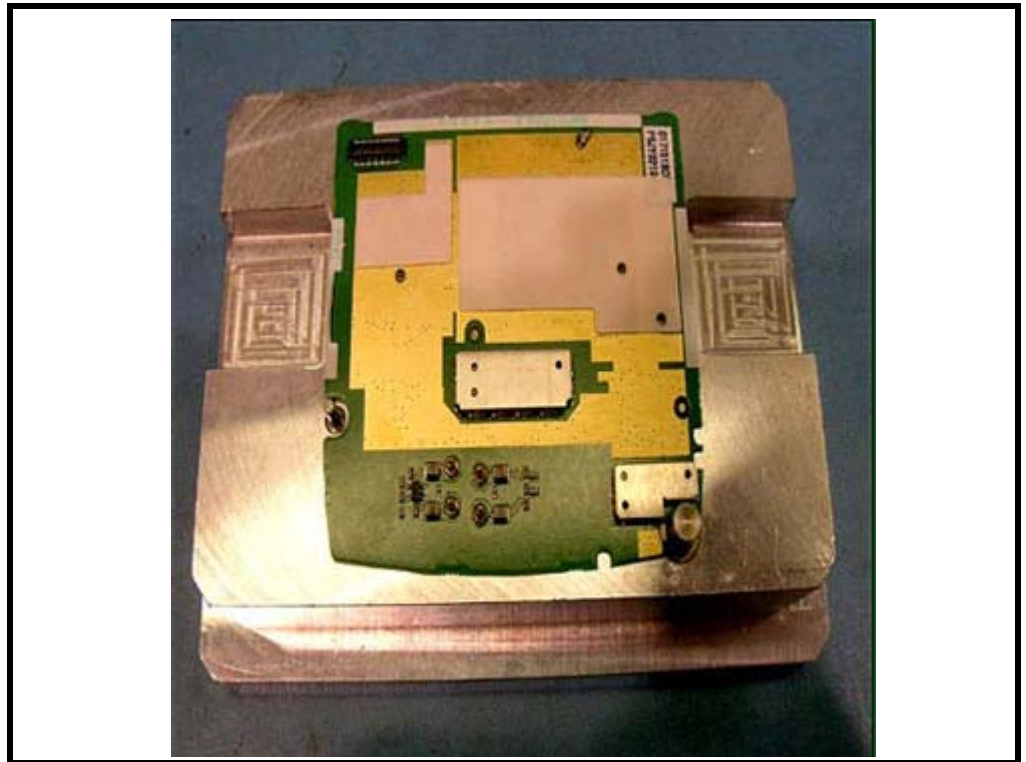

Figure 20. Keyboard Connector and Main board Connector Socket

0607930

7. Attach Bootstrap as shown. Apply “L” shaped adhesive to Main board and align with the edges of the shield (see Figure 21). Remove the adhesive liner before attaching to keyboard.

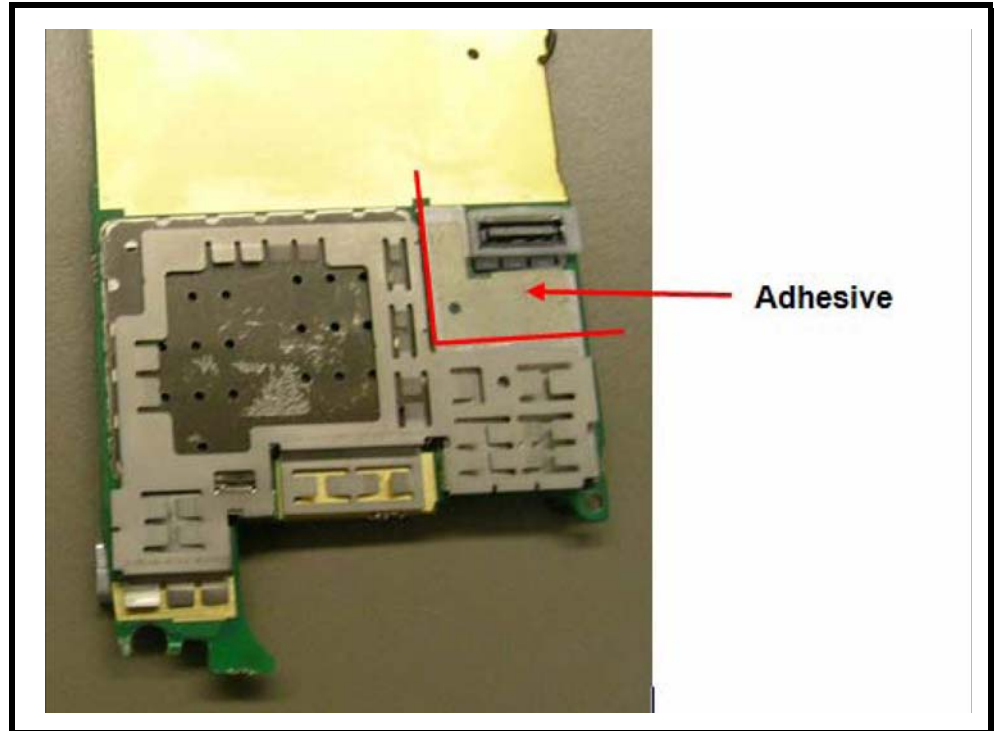
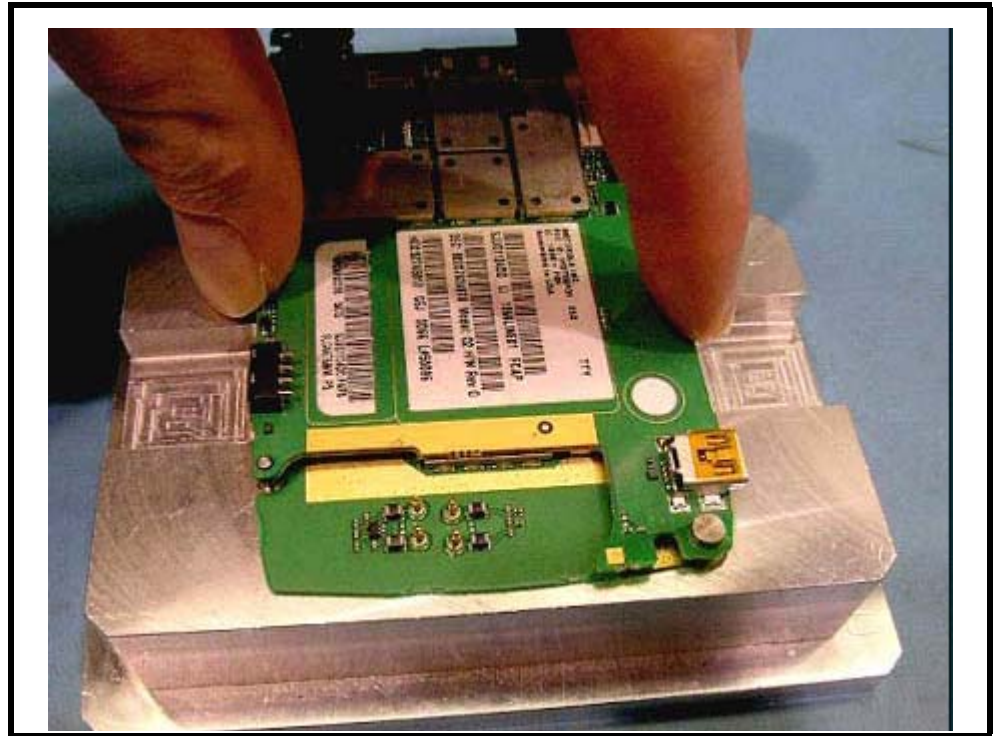

Figure 21. Aligning the Keyboard Adhesive Tape

8. Attach the main board to the keyboard using the keyboard assembly fixture (see Figure 22). Avoid contact with nearby board components.



0607940

Figure 22. Keyboard Assembly Fixture

9. Press fixture should be set to exert 19 lbf (8,620 gf) at the ram head for 5 seconds. The input pressure can be calculated using the required force & the area of the pistons; $P=F/A$.
10. Carefully place PCB assembly into the press fixture. Use the alignment pins to hold assembly in place.
11. Once PCB assembly is in place, press the 2 buttons on the side of the fixture.

12. Apply Main Board to Key Board conductive gasket as shown.

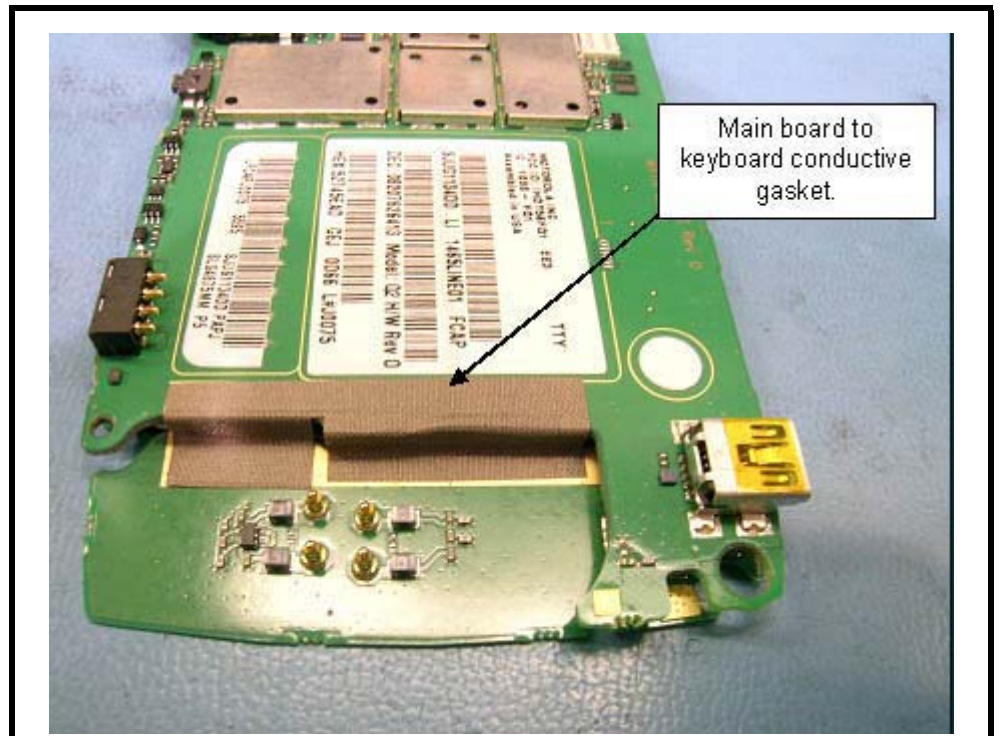

0607940

Figure 23. Keyboard Assembly Fixture

13. Replace the main board, daughter board, antenna, rear housing, battery and battery door as described in the procedures.

Removing the Display Assembly

1. Remove the battery door, battery, rear housing, antenna, daughter board, camera assembly, speaker carrier, main board, and keyboard as described in the procedures.
2. Use the metal tweezers to release the display module catches in the order shown in Figure 24.

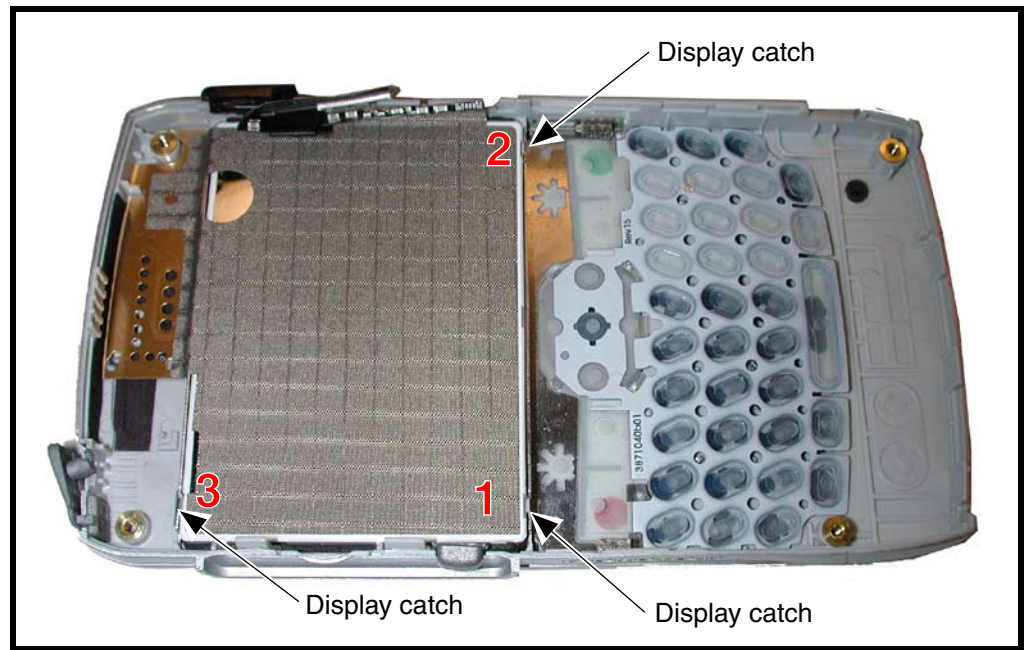

Figure 24. Removing the Display Assembly Catches

0604270

3. Apply a small amount of force to the lower right side of the display assembly and lift the left side of the display out of the front housing (see Figure 25).

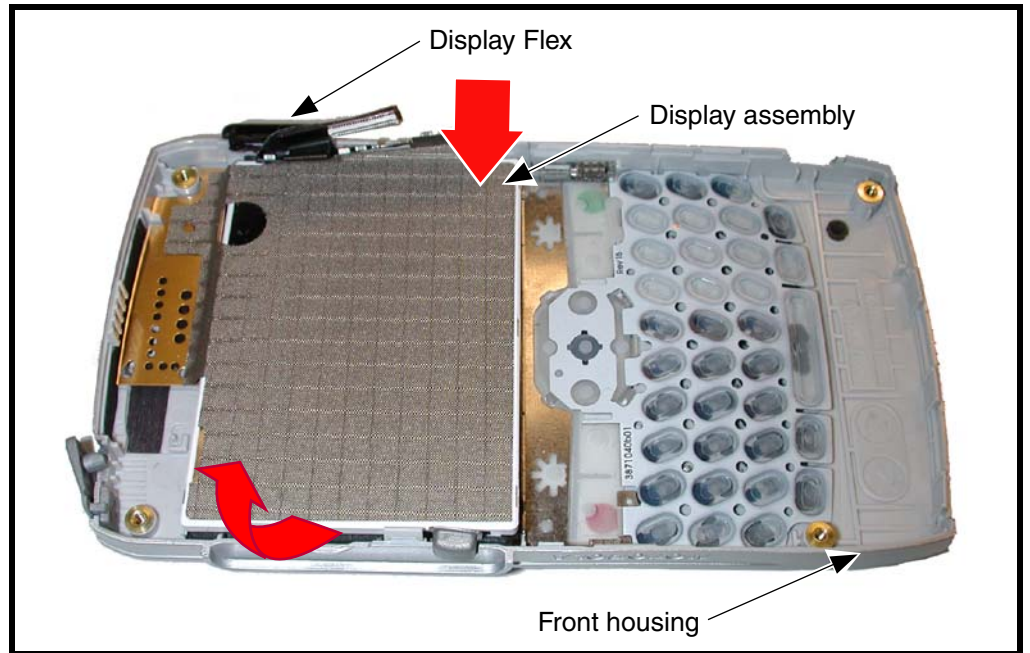

Figure 25. Removing the Display Assembly



The flexible printed cable (FPC) (flex) is easily damaged. Exercise extreme care when handling.

4. Carefully lift the right side of the display assembly out of the front housing.
5. To replace, align the display assembly to the front housing.
6. Carefully insert the right side of the display assembly into the front housing.
7. Carefully lower the left side of the display assembly into the front housing.
8. Apply slight pressure to all four corners of the display assembly to ensure that all four display assembly catches are properly engaged.
9. Replace the keyboard, main board, daughter board, antenna, rear housing, battery and battery door as described in the procedures.

Removing and Replacing the Keypad

1. Remove the antenna, battery cover, battery, rear housing assembly, flex connector, transceiver board assembly, and keyboard as described in the procedures.
2. Use the metal tweezers to lift the keypad from the front housing as shown in Figure 26.

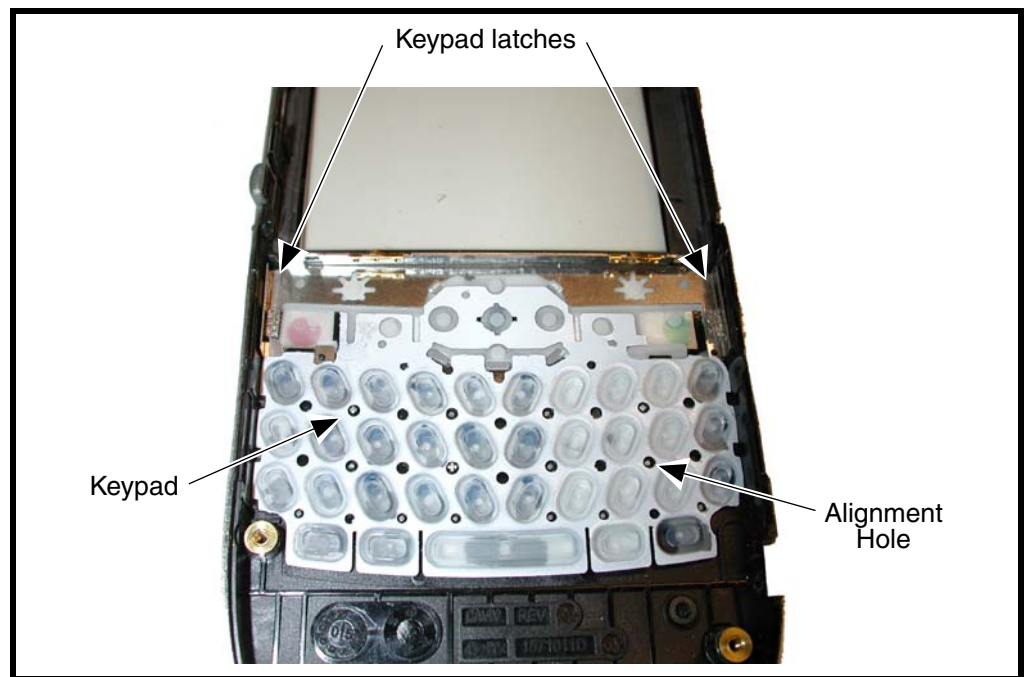

060318c

Figure 26. Removing the Keypad

3. To replace, insert the keypad into the front housing. Align the slots at the sides of the keypad metal supports to the keypad latches in the front housing.
4. Top tab of keypad should fit underneath the main lens.
5. Ensure the alignment holes align properly with the alignment pins in the front housing.
6. Replace the keyboard, main board, camera assembly, daughter board, antenna, rear housing assembly, battery, and battery door as described in the procedures.

Phone Identification

Personality Transfer

A personality transfer is required when a phone is express exchanged or when the main board is replaced. Personality transfers reproduce the customer's original personalized details such as menu and stored memory, such as phone books, or even just program a unit with basic user information such as language selection.

Identification

Each Motorola CDMA phone is labeled with a variety of identifying numbers. Figure 27 describes the current identifying labels.

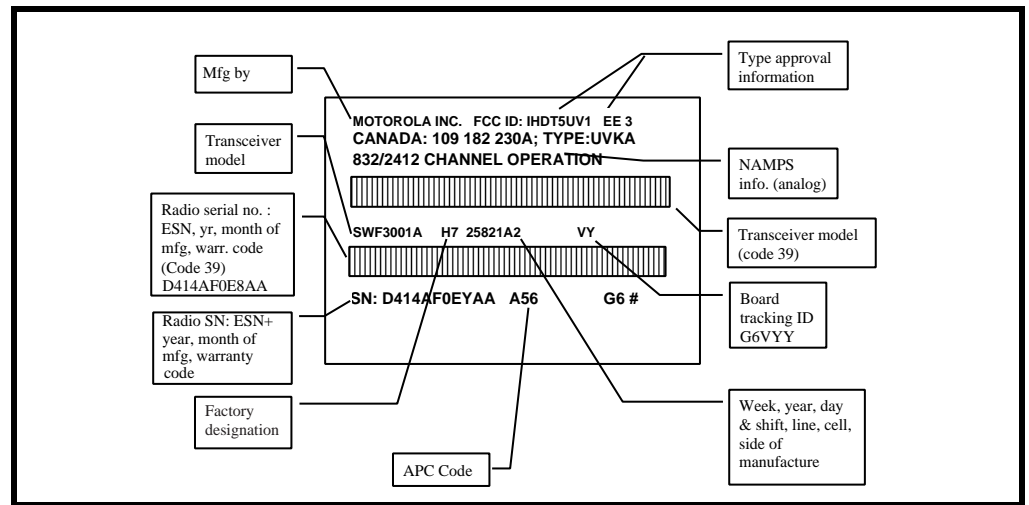

Figure 27. CDMA Telephone Identification Label

020463o

Troubleshooting

Table 2. Level 1 and 2 Troubleshooting Chart

Symptom	Probable Cause	Verification and Remedy
1. Telephone will not turn on or stay on.	a) Battery either discharged or defective.	Measure battery voltage across a 50 ohm (>1 Watt) load. If the battery voltage is <3.25 Vdc, recharge the battery using the appropriate battery charger. If the battery will not recharge, replace the battery. If battery is not at fault, proceed to b.
	b) Battery connectors open or misaligned.	Visually inspect the battery connectors on both the battery and the telephone. Realign and, if necessary, either replace the battery or refer to a Level 3 Service Center for the battery connector replacement. If battery connectors are not at fault, proceed to c.
	c) Transceiver board defective.	Remove the transceiver board. Substitute a known good transceiver board and temporarily reassemble the unit. Press the PWR button; if unit turns on and stays on, disconnect the dc power source and reassemble the telephone with the new transceiver board. Verify that the fault has been cleared. If the fault has not been cleared then proceed to d.
	d) keyboard assembly failure.	Replace the keyboard assembly. Temporarily connect a +3.6 Vdc supply to the battery connectors. Depress the PWR button. If unit turns on and stays on, disconnect the dc power source and reassemble with the new keyboard assembly.
2. Telephone exhibits poor reception or erratic operation such as calls frequently dropping or weak or distorted audio.	a) Antenna assembly defective.	Check to make sure that the antenna pin is properly connected to the transceiver board assembly. If connected properly, substitute a known good antenna. If the fault is still present, proceed to b.
	b) Transceiver board defective.	Replace the transceiver board (refer to 1c). Verify that the fault has been cleared and reassemble the unit with the new transceiver board.
3. Display is erratic, or provides partial or no display.	a) Connections to or from transceiver board defective.	Check general condition of flex and flex connector. If the flex and connector are good, check that the flex connector is fully connected. If not, check connector to transceiver board connections. If faulty connector, replace the transceiver board. If connector is not at fault, proceed to b.
	b) Transceiver board assembly defective.	Replace the transceiver board (refer to 1c). Verify that the fault has been cleared and reassemble the unit with the new transceiver board.
4. Incoming call alert transducer audio distorted or volume is too low.	Faulty transceiver board assembly.	Replace the transceiver board (refer to 1c). Verify that the fault has been cleared and reassemble the unit with the new transceiver board.
5. Telephone transmit audio is weak. (usually indicated by called parties complaining of difficulty in hearing voice).	a) microphone obstructed by user while holding the phone	Verify transmit audio quality. If transmit audio quality is still weak and microphone is not obstructed, proceed to b.
	b) keyboard assembly defective	Replace the keyboard assembly with a know good keyboard assembly. Verify that the fault is cleared and reassemble the unit with the new keyboard assembly. If this does not clear the fault, reinstall the original keyboard assembly and proceed to c

Table 2. Level 1 and 2 Troubleshooting Chart (Continued)

Symptom	Probable Cause	Verification and Remedy
	c) Transceiver board assembly defective.	Replace the transceiver board assembly (refer to 1c). Verify that the fault has been cleared and reassemble the unit with the new transceiver board assembly.
6. Receive audio from earpiece speaker is weak or distorted.	a) Earpiece speaker defective.	Check speaker connections. If connections are at fault, replace speaker. If connection is not at fault, proceed to b.
	b) Antenna assembly defective.	Check to make sure the antenna is installed correctly. If the antenna is installed correctly, substitute a known good antenna assembly. If this does not clear the fault, reinstall the original antenna assembly and proceed to c.
	c) Transceiver board assembly defective.	Replace the transceiver board assembly (refer to 1c). Verify that the fault has been cleared and reassemble with the new transceiver board assembly.
7. Vibrator feature not functioning.	Motor/Vibrator assembly defective.	Replace the Motor/Vibrator assembly. Verify that the fault has been cleared and reassemble the unit with the new Motor/Vibrator assembly.
8. Internal Charger not working.	Faulty charger circuit on transceiver board assembly.	Test a selection of batteries in the rear pocket of the desktop charger. Check LED display for the charging indications. If these are charging properly, then the internal charger is at fault. Replace the transceiver board assembly (refer to 1c). Verify that the fault has been cleared and reassemble the unit with the new transceiver board assembly.
9. No or weak audio when using headset.	a) Headset not fully pushed home.	Ensure the headset plug is fully seated in the jack socket. If fault not cleared, proceed to b.
	b) Faulty jack socket on transceiver board assembly.	Replace the transceiver board assembly (refer to 1c). Verify that the fault has been cleared and reassemble the unit with the new transceiver board assembly.

Programming: Software Upgrade and Flexing

Contact your local technical support engineer for information about equipment and procedures for flashing and flexing.

Exploded View Diagram

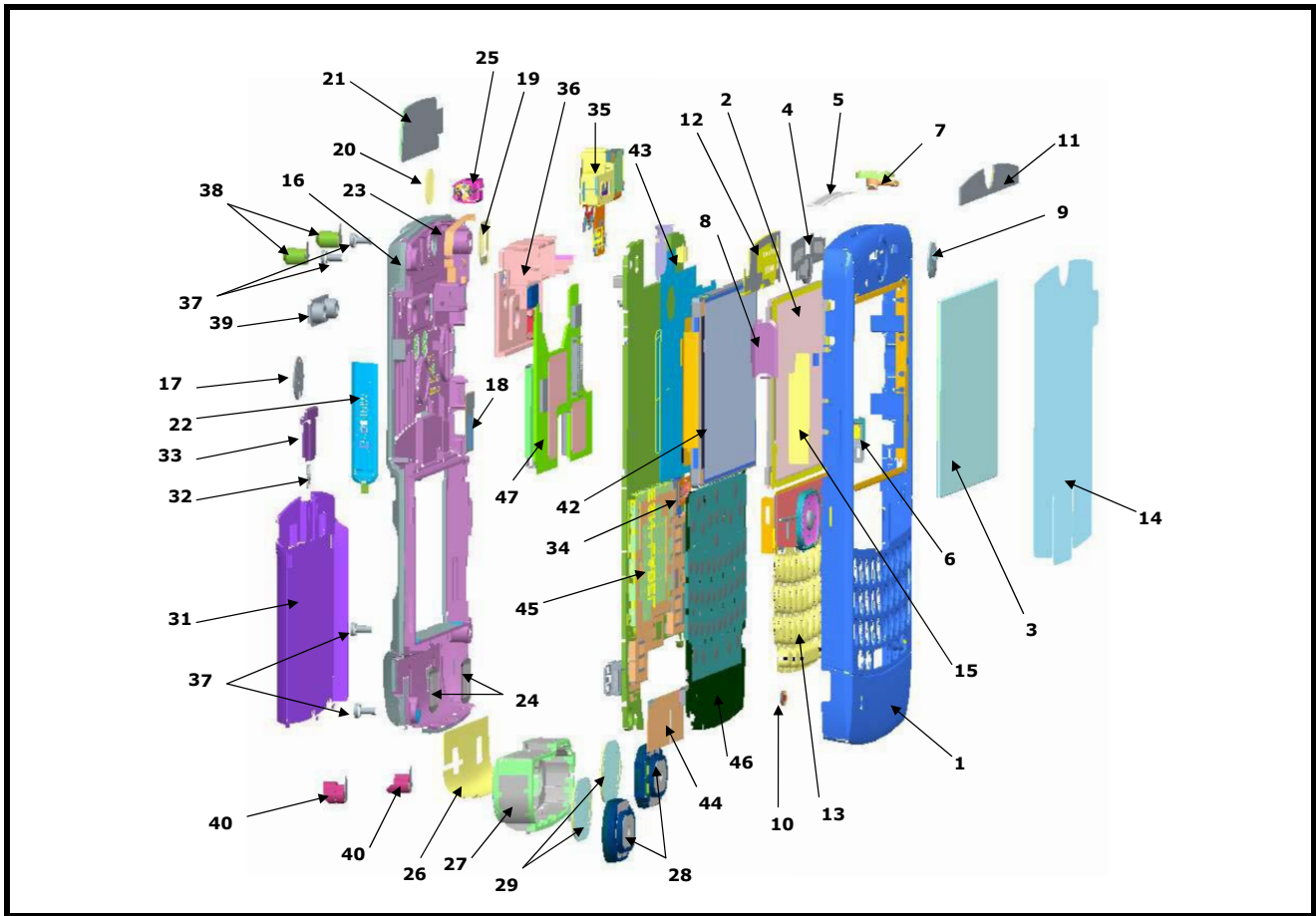

0601650

Figure 28. Exploded View

Exploded View Parts List

Table 3. Exploded View Parts List

Item Number	Part Number	Description	Item Number	Part Number	Description
1	1571191C01	Front Housing painted, Satellite silver	26	8571830B01	PIFA antenna Bottom
2	3289157Y01	Gasket, Main 2.4 Display	27	1571014D01	CDMA Speaker carrier
3	6171110B01	Main Lens	28	5088317Y01	Loud Speaker -14 X 20
4	3571822B01	Screen, earpiece primary	29	3571269B01	Screen, Loudspeaker
5	3571823B01	Screen, earpiece tertiary	30		
6	3871041B01	Side Button, Silver	31	1571337C01	Battery door standard, satellite silver
7	0571010D01	HSJ Grommet, Dark Silver	32	4171793B01	Battery latch spring
8	6171030D01	IRDA Lens	33	5571196C01	Battery door latch, plated
9	1371115B01	Batwing Front	34	4271169D01	Board to board support block
10	3571294C01	Screen, MIC	35	8471427B01 0571013D01 8490009N03	Camera Module -1.3 CDMA receiver camera Grommet Ear speaker assembly
11	6471043B01	Decorative Bezel	36	0771495C01 8571174B01 8571434C01	CDMA antenna carrier PIFA antenna Top A PIFA antenna Top B
12	6471081C01	SAR Shield	37	0387587Y01	Screws (4X)
13	3871040B01	Keypad Assembly, CDMA	38	3871405C01	Screw hole plug, top satellite silver (2X)
14	1171571C01	Front Liner	39	0571339C01	RF grommet, satellite silver
15	3271378D01	Display side gasket (conductive)	40	3871200C01	Screw hole plug, bottom l, satellite silver
16	1571012D02	Rear housing painted, Satellite silver	41	3871199C01	Screw hole plug, bottom r, satellite silver
17	1371107B01	Batwing Rear	42	7289804Y01	Display -inner module 2.4" TM QVGA
18	8571175B01	Bluetooth Antenna	43	3271826B01	Conductive fabric SAR shield
19	6171112B01	Flash lens	44	3271720C01	Grounding gasket for main board-key board
20	6187835N02	Lens, Camera, w/Adhesive	45	0171520C01	Main board assembly
21	1371125B01	Camera Bezel CDMA	46	0171518C04	Keyboard assembly
22	0571153C01	Mini SD Grommet, Satellite Silver	47	0171521C04	Daughter board assembly
23	8571176B01	GPS antenna			
24	3571419B01	Screen, Rear Port			
25	0171267C02	Vibrator Motor Assembly			

Accessories

Table 4. Accessories

Description	Part Number
Power Solutions	
Battery Slim Li Ion (1130mAh)	SNN5783B
Battery High Performance (1640mAh)	SNN5765A
Travel Charger Rapid U.S. (non-leakage)	PSM5202A
In-Vehicle Solutions	
Bluetooth Car Kit	S9642
Self Install HF Retractable (Razorbill)	SYN0613
Professional Install Car Kit (Junction Box Only)	S9950
HUC for PCC	TBD
Low Tier VPA Mid rate	
VPA Verizon Exclusive Rapid	SYN9901
Vehicle Power Adapter, New ID Rapid	SYN0707
Audio & Connectivity	
Paladin Bluetooth Headset	SYN9826A
Caller ID Bluetooth Headset	TBD
Quadrant Bluetooth Speaker	TBD
Qwerty Bluetooth Keyboard	TBD
Platform Stereo Headset	TBD
FM Stereo Headset	SYN8609
Retractable Headset (new customizable)	SYN9050
One Touch Headset (new customizable)	SYN9351
Mono Headset Black	SYN8390B
Mono Headset Silver	AAYN4264A
Mono Headset (new customizable)	SYN9350
Over the Ear Headset	SYN8908
Neck Loop headset	SYN7875
USB 2.0 Card Reader	SYN1045A
Consumer Personalization	
Carry Cases	TBD
Lanyard	SYN9490A
Holster	TBD
Belt Clip	SYN8763

A

antenna, removing and replacing 24

B

battery

charge indicator 15

function 15

removing 20

battery cover, removing and replacing 19

C

Canadian Interference-Causing Equipment regulations 4

copyrights

computer software 5

D

disassembly 18

display assembly, removing and replacing 36

E

exploded view diagram 42

exploded view parts list 43

F

FCC rules 4

I

identification 39

product 4

Introduction 4

K

Keyboard, removing and replacing 30

keypad

removing 38

keypad, removing and replacing 38

M

Main Board, removing and replacing 28

menu structure 15

motor/vibrator Assembly, removing and replacing 23

N

names

product 4

O

operation 11

battery 15

controls, indicators, and I/O connectors 11

menu navigation 12

menu structure 15

overview, product 9

P

parts

exploded view diagram 42

exploded view parts list 43

product

identification 4

names 4

product overview 9

features 9

R

regulatory agency compliance 4

removing

antenna 24

battery 15, 20

battery cover 19

display assembly 36

Keyboard 30

keypad 38

Main Board 28

motor/vibrator 23

speaker carrier 27

replacement parts

ordering 7

replacing

antenna 24

battery 20

battery cover 19

display assembly 36

Keyboard 30

keypad 38

Main Board 28

motor/vibrator assembly 23

speaker carrier 27

S

service manual

about 5

audience 5

conventions 6

scope 5

service policy 6
 customer support 6
 out of box failure 6
 product support 6
shut down
 upon battery removal 15
SIM card
 personality transfer 39
speaker carrier, removing and replacing 27
specifications 8
support
 customer 6
 product 6

T

tools and test equipment 17

W

warranty service 6



MOTOROLA