

ARIB TR-T12-27.A01 V3.3.0

**Report on External Interface
Connectors**

This report was originally written by the Association of Radio Industries and Businesses (ARIB), based on 3GPP TR27.901 4.2 Conclusion.

The copyrights for this document are ascribed to ARIB.

Reference

Keywords

< ARIB, physical interface, USB, connector >

ARIB

Postal address

Nittochi Bldg. 11F, 1-4-1, Kasumigaseki,
Chiyoda-ku, Tokyo 100-0013, Japan
TEL 81-3-5510-8594
FAX 81-3-3592-1103

Internet

<http://www.arib.or.jp/IMT-2000/>

Contents

1	SCOPE of application (usage)	7
2	Normative references	7
3	Definition of the specified interface point	7
4	Connector A specification	8
4.1	Configuration	8
4.1.1	Pin assignment	8
4.1.2	Pin functions	9
4.2	Operating environmental conditions	9
4.2.1	Temperature condition	9
4.2.2	Humidity condition	9
4.3	Technical requirements	9
4.3.1	Frequency range	9
4.3.2	Electrical characteristics	10
4.3.2.1	Rating	10
4.3.2.1.1	Rated voltage	10
4.3.2.1.2	Rated current	10
4.3.2.1.3	Insulation resistance	10
4.3.2.1.4	Withstand voltage	10
4.3.2.1.5	Contact resistance	10
4.3.2.1.6	Contact capacitance	10
4.3.2.2	Signal characteristics	10
4.3.2.2.1	User signal for data communication	10
4.3.2.2.2	Clock signal for synchronous communication	10
4.3.2.2.3	Manufacturer specific pin	10
4.3.2.2.4	Reserved pin	11
4.3.3	RF line characteristics	11
4.3.3.1	Maximum input power	11
4.3.3.2	Impedance	11
4.3.3.3	Insertion loss	11
4.3.3.4	VSWR	11
4.4	Operating procedure	11
4.4.1	Clock signal for synchronous communication	11
4.4.1.1	Initial state	11
4.4.1.2	Usage procedure	11
4.4.1.3	Connector release procedure	12
4.4.2	Manufacturer specific pin	12
4.4.2.1	Initial state	12
4.4.2.2	Usage procedure	12
4.4.2.3	Connector release procedure	12
4.4.3	Reserved pin	12
4.4.3.1	Initial state	12
4.4.3.2	Connector release procedure	12
4.5	Physical conditions	13
4.5.1	Shape	13
4.5.2	Hot plug	13
4.5.3	Dimensions	13
4.5.4	Tolerance	13
4.6	Physical strength characteristics	13
4.6.1	Insertion force and extraction force	13
4.6.2	Durability	13
4.6.3	Vibration	13
4.6.4	Shock resistance	13
4.6.5	Locking strength	13
4.7	Climate resistance	13
4.7.1	Humidity resistance, steady state	13

4.7.2	Thermal cycle characteristics	13
4.7.3	Dry heat resistance	14
4.7.4	Cold resistance	14
4.7.5	Salt water mist	14
4.7.6	Solder-heat resistance	14
5	Connector B specification	15
5.1	Configuration	15
5.1.1	Pin assignment	15
5.1.2	Pin functions	15
5.2	Operating environmental conditions	16
5.2.1	Temperature condition	16
5.2.2	Humidity condition	16
5.3	Technical requirements	16
5.3.1	Electrical characteristics	17
5.3.1.1	Rating	17
5.3.1.1.1	Rated voltage	17
5.3.1.1.2	Rated current	17
5.3.1.1.3	Insulation resistance	17
5.3.1.1.4	Withstand voltage	17
5.3.1.1.5	Contact resistance	17
5.3.1.1.6	Contact capacitance	17
5.3.1.2	Signal characteristics	17
5.3.1.2.1	User signal for data communication	17
5.3.1.2.2	Clock signal for synchronous communication	17
5.4	Operating procedure	18
5.4.1	Clock signal for synchronous communication	18
5.4.1.1	Initial state	18
5.4.1.2	Usage procedure	18
5.4.1.3	Connector release procedure	19
5.4.2	Manufacturer specific pin	19
5.5	Physical conditions	19
5.5.1	Shape	19
5.5.2	Hot plug	19
5.5.3	Dimensions	19
5.5.4	Tolerance	19
5.6	Physical strength characteristics	19
5.6.1	Insertion force	19
5.6.2	Durability	19
5.6.3	Vibration	20
5.6.4	Shock resistance	20
5.6.5	Locking strength	20
5.7	Climate resistance	20
5.7.1	Humidity resistance, steady state	20
5.7.2	Thermal cycle characteristics	20
5.7.3	Dry heat resistance	20
5.7.4	Cold resistance	20
5.7.5	Salt water mist	20
5.7.6	Solder-heat resistance	20
6.	Connector C specification	21
6.1	Configuration	21
6.1.1	Pin assignment	21
6.1.2	Pin functions	22
6.2	Operating environmental conditions	23
6.2.1	Temperature condition	23
6.2.2	Humidity condition	23
6.3	Technical requirements	23
6.3.1	Frequency range	23
6.3.2	Electrical characteristics	23
6.3.2.1	Rating	23
6.3.2.1.1	Rated voltage	23

6.3.2.1.2	Rated current	23
6.3.2.1.3	Insulation resistance	23
6.3.2.1.4	Withstand voltage	23
6.3.2.1.5	Contact resistance	23
6.3.2.1.6	Contact capacitance	24
6.3.2.2	Signal characteristics	24
6.3.2.2.1	User signal for data communication	24
6.3.2.2.2	Clock signal for synchronous communication	24
6.3.2.2.3	Manufacturer specific pin	24
6.3.2.2.4	Reserved pin	24
6.3.2.2.5	MIC In pin	24
6.3.2.2.6	EXT DET pin	25
6.3.2.2.7	Audio Right / Left pin	25
6.3.2.2.8	Stereo DET pin	25
6.3.2.2.9	Power Out pin	25
6.3.2.2.10	Switch DET pin	25
6.3.2.2.11	Reserved 2 pin	25
6.3.3	RF line characteristics	25
6.3.3.1	Maximum input power	25
6.3.3.2	Impedance	25
6.3.3.3	Insertion loss	26
6.3.3.4	VSWR	26
6.4	Operating procedure	26
6.4.1	Clock signal for synchronous communication	26
6.4.1.1	Initial state	26
6.4.1.2	Usage procedure	26
6.4.1.3	Connector release procedure	26
6.4.2	Manufacturer specific pin	26
6.4.2.1	Initial state	27
6.4.2.2	Usage procedure	27
6.4.2.3	Connector release procedure	27
6.4.3	Reserved pin	27
6.4.3.1	Initial state	27
6.4.3.2	Connector release procedure	27
6.4.4	EXT DET pin	27
6.4.4.1	Initial state	27
6.4.4.2	Usage procedure	27
6.4.4.3	Connector release procedure	27
6.4.5	Stereo DET pin	28
6.4.5.1	Initial state	28
6.4.5.2	Usage procedure	28
6.4.5.3	Connector release procedure	28
6.4.6	Switch DET pin	28
6.4.6.1	Initial state	28
6.4.6.2	Usage procedure	28
6.4.6.3	Connector release procedure	28
6.4.7	Reserved 2 pin	28
6.4.7.1	Initial state	28
6.4.7.2	Connector release procedure	29
6.5	Physical conditions	29
6.5.1	Shape	29
6.5.2	Hot plug	29
6.5.3	Dimensions	29
6.5.4	Tolerance	29
6.6	Physical strength characteristics	29
6.6.1	Insertion force and extraction force	29
6.6.2	Durability	29
6.6.3	Vibration	29
6.6.4	Shock resistance	29
6.6.5	Locking strength	29
6.7	Climate resistance	30
6.7.1	Humidity resistance, steady state	30

6.7.2	Thermal cycle characteristics	30
6.7.3	Dry heat resistance	30
6.7.4	Cold resistance	30
6.7.5	Salt water mist	30
6.7.6	Solder-heat resistance	30
Annex A: Power supply line (charge) characteristics - Connector A and Connector C		31
Annex B: Connector release procedure		31
Annex C: Change history		31
History		32

1 Scope of application (usage)

This ARIB Optional Standard provides the mechanical and electrical specifications for the Connectors used to interconnect IMT-2000 Mobile Equipment (ME) with an external accessory and/ or Terminal Equipment (TE). The specification includes the dimension, pin assignment including USB pins, pin functionality, electrical, and reliability requirements. This ARIB document describes the minimum requirements for the external interface for IMT-2000 ME.

This ARIB Optional Standard includes three types of connectors. One is a 10-pin + RF pin type called Connector A. Another is a 5-pin type called Connector B. The other is a 20-pin + RF pin type called Connector C. All types are optional standards, and this standard does not exclude the use of other connectors e.g. manufacturer proprietary solutions [4].

2 Normative references

The following documents contain provisions, which, though reference in this text, constitute provisions of the present document.

- [1] Universal Serial Bus Specification Revision 1.1
- [2] EIAJ RC-5238
- [3] EIAJ RC-5239
- [4] 3G TR 27.901 Report on terminal interfaces – An overview
- [5] JEITA standard RC-5242

3 Definition of the specified interface point

The interface point is an external interface between an IMT-2000 ME and an external accessory and/ or terminal equipment (e.g. PC's and car kits).

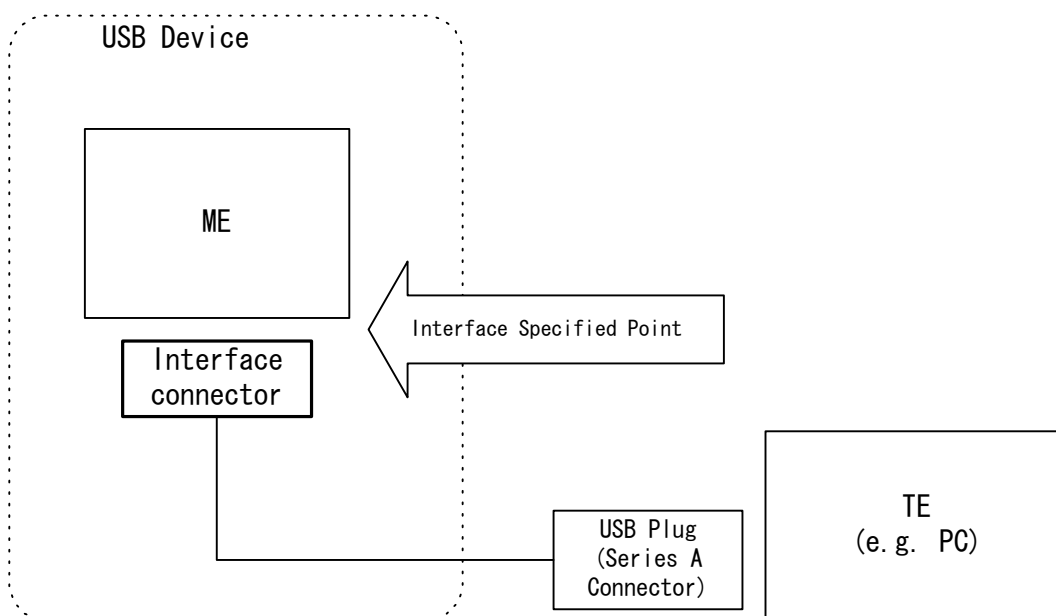

Figure 1: Definition of the specified interface point

4 Connector A specification

4.1 Configuration

The Universal Serial Bus (USB) -based interface is specified for the electrical interface. The ME acts as a USB device. The USB-based electrical interface is compatible with PCs and it can connect to PCs directly. Furthermore, it is fast (12Mbps), and it has a multiplexed data transmission capability to support multi-media/multi-call services in IMT-2000 systems. Figure 2 shows the configuration of the USB-based interface. Between the ME and the TE, USB pipes are assigned for each service or for each call. Manufacturers and operators can use the USB vendor class for additional functions. For other functions, the USB Implementers Forum should define the new USB classes. For the connector’s USB interface, EIAJ RC-5238 is a normative reference.

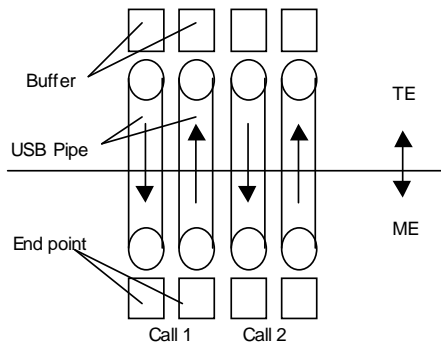

Figure 2: Configuration of the USB based interface.

4.1.1 Pin assignment

Table 1 and Figure 3 show the pin assignment of the Connector A. The specification of this connector is optional, and manufacturers can use other types of connectors. However, the rules and restrictions described in this section shall be applied when the connector specified by EIAJ RC-5238 is used.

Table 1: Pin Assignment of Connector A

No	NAME	Direction		NOTE
		ME	EXT	
1	GND (USB GND)	---		
2	USB D+	<<<<>>>		
3	USB D-	<<<<>>>		
4	USB VBUS	<<<		
5	Power Supply	<<<		
6	Reserved	Reserved		Refer to 4.4.3 (Reserved for future power supply)
7	Synchronisation Clock	>>>		
8	Manufacturer Specific	<<<<>>>		
9	Reserved	Reserved		Refer to 4.4.3
10	GND	---		
RF	RF TRX	<<<<>>>		Coaxial

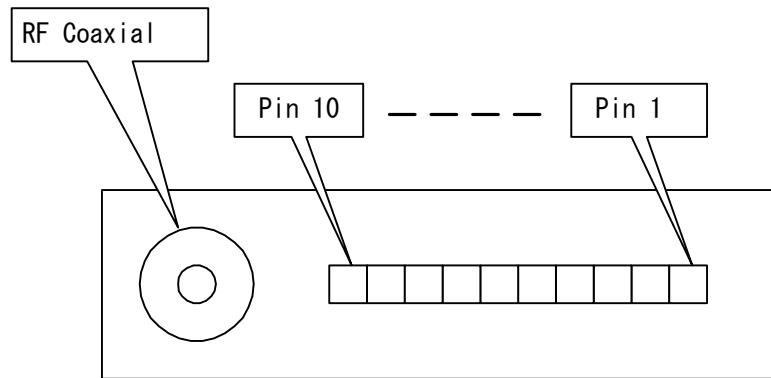

Figure 3: Pin Assignment of the Connector A.
(note: Connector mounted direction is not specified.)

4.1.2 Pin functions

The connector consists of ten pins and one coaxial contact. It supports USB, power supply, clock, and RF input/output functions. The ME serves external equipment with a clock that synchronises with the transmission rate of the radio (air) interface. If external equipment (TE etc.) supports real-time applications, e.g., voice communication or ISDN, it can use the clock to synchronise the application's clock synchronised with the data. For the power supply pin (5), the maximum voltage and maximum average current are specified. External equipment (TE etc.) that supplies the ME with power must not supply the voltage over the specified maximum voltage, and it must limit the current to the specified maximum average current. The ME can select/limit the external equipment by means of logical negotiation through the manufacturer specific pin (8). For example, manufacturers can limit the range of supplied voltage by selecting the power adapters to be connected to the ME. The pins (6,9) are the reserved pins, and the manufacturer can not use the pins (6,9) freely. After the negotiation is successfully completed, all pins can be used without restraint. When the supplied voltage through the pin (4) is below a USB VBUS voltage specified in "Universal Serial Bus Specification Revision 1.1" [1](USB Implementers Forum), the ME may act as a non-USB device. In this case, The ME can change the pins function temporarily except the pins (1,5,10).

4.2 Operating environmental conditions

4.2.1 Temperature condition

For temperature conditions refer to EIAJ standard RC-5238.

4.2.2 Humidity condition

For humidity conditions refer to EIAJ standard RC-5238.

4.3 Technical requirements

Below is the definition of the connector A technical requirements.

4.3.1 Frequency range

The radio frequency range for RF TRX pin is 1.92GHz to 2.17GHz.

4.3.2 Electrical characteristics

4.3.2.1 Rating

The rating conditions below apply to all pins except to the RF TRX pin.

4.3.2.1.1 Rated voltage

Rated voltage is 30V.

4.3.2.1.2 Rated current

Rated current is 0.5A for 2,3,4,7,8,9pins and 1.0A for 1,5,6,10pins

4.3.2.1.3 Insulation resistance

For insulation resistance refer to EIAJ standard RC-5238.

4.3.2.1.4 Withstand voltage

For withstand voltage refer to EIAJ standard RC-5238.

4.3.2.1.5 Contact resistance

For contact resistance refer to EIAJ standard RC-5238.

4.3.2.1.6 Contact capacitance

For contact capacitance refer to EIAJ standard RC-5238.

4.3.2.2 Signal characteristics

Below is the definition of the signal characteristics.

4.3.2.2.1 User signal for data communication

For signal characteristics of USB D+, USB D- and USB VBUS refer to “Universal Serial Bus Specification Revision 1.1” [1](USB Implementers Forum).

4.3.2.2.2 Clock signal for synchronous communication

Below is the definition of the synchronisation clock pin.

Electrical condition :CMOS 3V \pm 0.3V.High impedance at unused time.($>$ 200 k Ω)

Frequency: 64kHz (duty=1:1)

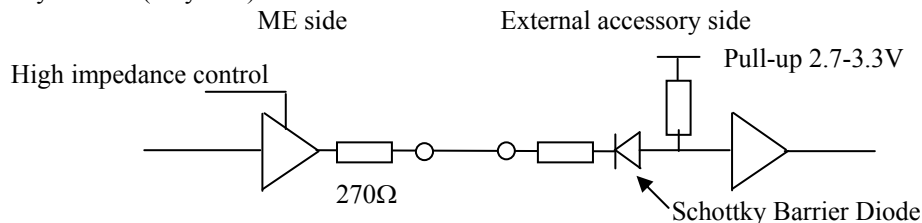

Figure 4: Output-input characteristics of the clock signal. (The input circuit is reference.)

4.3.2.2.3 Manufacturer specific pin

Below is the definition of the Manufacturer specific pin.

High impedance at unused time.($>$ 200 k Ω)

The maximum voltage of the Manufacturer specific pin is limited to less than 3.6 V.

4.3.2.2.4 Reserved pin

Below is the definition of the Reserved pins.

High impedance at unused time.($> 200 \text{ k}\Omega$)

The maximum voltage of the Reserved pins is limited to less than 3.6 V.

4.3.3 RF line characteristics

Below is the definition of the RF TRX pin.

4.3.3.1 Maximum input power

Maximum input power is less than 2W.

4.3.3.2 Impedance

Impedance is 50Ω .(Nominally)

4.3.3.3 Insertion loss

Insertion loss is less than 0.5dB.

4.3.3.4 VSWR

VSWR is less than 1.5.

4.4 Operating procedure

Below defines the connector A operating procedure.

4.4.1 Clock signal for synchronous communication

This pin is defined to address the synchronisation between mobile equipment (ME) and the external equipment (EXT: TE etc) connected to each other via the external interface of the ME. In a mobile network there exist one master clock source, which provides the accurate frequency signal to all the equipment in the network. The ME can extract the accurate frequency signal from received RF signal. If an external equipment is connected to the ME via external interface, and if the synchronisation clock is provided from ME to EXT, the EXT can run with the clock. If an EXT and, for example, an ISDN terminal (or video viewer, G4 FAX, etc.) are connected, then the EXT can take the timing provided from the network.

4.4.1.1 Initial state

Below defines the initial state.

ME: High impedance or No-connection (not in use)

EXT(peripheral): High impedance or No-connection (not in use)

4.4.1.2 Usage procedure

When the Synchronisation Clock is provided from the ME to the EXT (e.g. an UD adapter), the triggering of the Synchronisation Clock shall be done using one of the three procedures below:

1. If the EXT has a USB interface, and makes a request for the Synchronisation Clock, the EXT shall use USB

message for the requesting procedure.

2. If the EXT has a USB interface, and makes no request for the Synchronisation Clock, the ME can activate the Synchronisation Clock without any request from the EXT. In this case the EXT shall detect the Synchronisation Clock signal sent from the ME.
3. If the EXT has no USB interface, the ME can activate the Synchronisation Clock without any request from the EXT. In this case the EXT shall detect the Synchronisation Clock signal sent from the ME.

In both procedures 1 and 2, the USB interface shall be able to function both with and without the Synchronisation Clock signal.

4.4.1.3 Connector release procedure

After the connector is disconnected, the Synchronisation clock pin must return to the high impedance state in the ME.

4.4.2 Manufacturer specific pin

Each manufacturer defines this pin and the main foreseen functions that the pin takes are:

- To recognise the external terminal ID.
- To distinguish and to authenticate the connecting charger use safety or not safety.
- To change the pins function temporarily.

4.4.2.1 Initial state

ME: High impedance or No-connection (not in use)

EXT(peripheral): High impedance or No-connection (not in use)

4.4.2.2 Usage procedure

The identification can be analogue levels or it can be digital data code.

4.4.2.3 Connector release procedure

After the connector is disconnected, the manufacturer specific pin must return to the high impedance state in the ME.

4.4.3 Reserved pin

These pins are defined for future uses.

If pins function change with manufacturer specific pin, these reserved pins by definition can be used for any manufacturer specific function.

4.4.3.1 Initial state

ME: High impedance or No-connection (not in use)

EXT(peripheral): High impedance or No-connection (not in use)

4.4.3.2 Connector release procedure

After the connector is disconnected, the reserved pins must return to the high impedance state in the ME.

4.5 Physical conditions

4.5.1 Shape

For connector shape refer to EIAJ standard RC-5238.

4.5.2 Hot plug

The connector can be used for hot plug connection.

4.5.3 Dimensions

For connector dimensions refer to EIAJ standard RC-5238.

4.5.4 Tolerance

For connector tolerance refer to EIAJ standard RC-5238.

4.6 Physical strength characteristics

4.6.1 Insertion force and extraction force

For insertion force and extraction force refer to EIAJ standard RC-5238.

4.6.2 Durability

For durability refer to EIAJ standard RC-5238.

4.6.3 Vibration

For vibration refer to EIAJ standard RC-5238.

4.6.4 Shock resistance

For shock resistance refer to EIAJ standard RC-5238.

4.6.5 Locking strength

For locking strength refer to EIAJ standard RC-5238.

4.7 Climate resistance

4.7.1 Humidity resistance, steady state

For humidity resistance refer to EIAJ standard RC-5238.

4.7.2 Thermal cycle characteristics

For thermal cycle characteristics refer to EIAJ standard RC-5238.

4.7.3 Dry heat resistance

For dry heat resistance refer to EIAJ standard RC-5238.

4.7.4 Cold resistance

For cold resistance refer to EIAJ standard RC-5238.

4.7.5 Salt water mist

For salt water mist refer to EIAJ standard RC-5238.

4.7.6 Solder-heat resistance

For solder-heat resistance refer to EIAJ standard RC-5238.

5 Connector B specification

5.1 Configuration

The Universal Serial Bus (USB) -based interface is specified for the electrical interface. The ME acts as a USB device. The USB-based electrical interface is compatible with PCs and can connect to PCs directly. Furthermore, it is fast (12Mbps), and has a multiplexed data transmission capability that corresponds to multi-media/multi-call services in the IMT-2000 system. Figure 5 shows the configuration of the USB-based interface. Between a ME and TE, USB pipes are assigned for each service or for each call. Manufacturers and operators can use the USB vendor class for additional functions. For other functions, the USB Implementers Forum should define the new USB classes. For the connector of the USB interface, EIAJ RC-5239 is referred to.

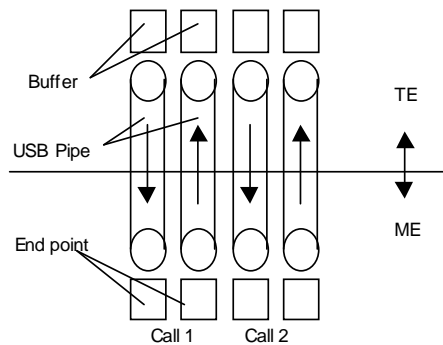

Figure 5: The configuration of the USB based interface.

5.1.1 Pin assignment

Table 2 shows the pin assignment of the connector B. The specification of this connector is optional, and manufacturers can use other types of connectors. However, the rules and restrictions described in this section shall be applied, if the connector specified by EIAJ RC-5239 is used.

Table 2: Pin assignment of the connector B

No	NAME	Direction		Note
		ME	EXT	
1	VBUS	---		
2	USB D-	<<<<>>>		
3	USB D+	<<<<>>>		
4	Synchronisation Clock	<<<<>>>		From ME to EXT: Synchronisation clock signal From EXT to ME: Manufacturer specific
5	Ground	---		

5.1.2 Pin functions

The connector consists of five pins and supports USB, clock output and manufacturer specific input functions. The pin functions of the connector are described below.

1. VBUS

USB power supply from host to mobile device.

2. USB D-

Bi-directional USB signal

3. USB D+

Bi-directional USB signal.

4. Synchronisation Clock

This pin serves two purposes 1) synchronisation clock for real-time data transmission and 2) manufacturer specific pin for accessory identification.

5. Ground

Ground reference for signals.

Figure 6 shows the pin numbering in the actual connector plug and proud pins.

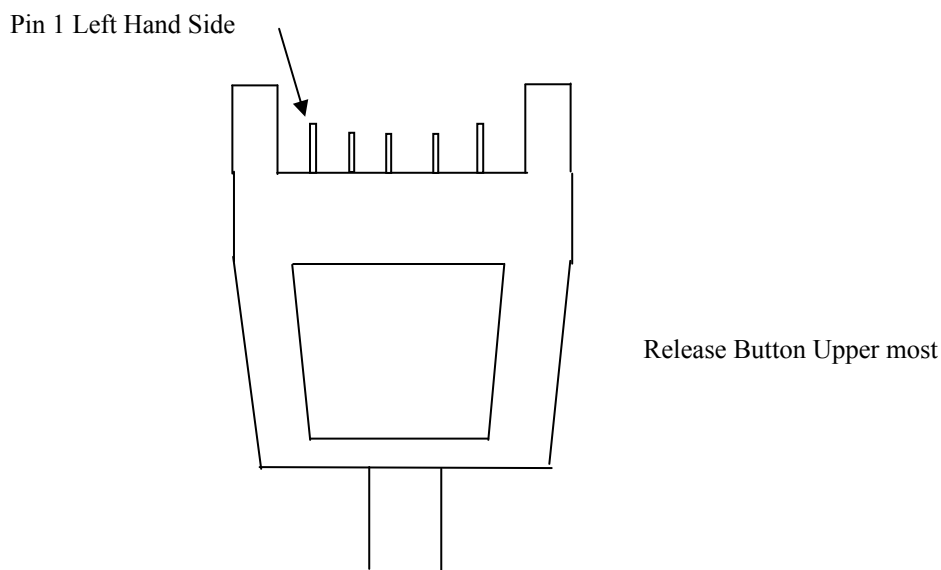

Figure 6: Pin numbering in the connector plug.

5.2 Operating environmental conditions

Below is the definition of the connector B operating environmental conditions.

5.2.1 Temperature condition

For temperature conditions refer to EIAJ standard RC-5239.

5.2.2 Humidity condition

For humidity conditions refer to EIAJ standard RC-5239.

5.3 Technical requirements

Below is the definition of the connector B technical requirements.

5.3.1 Electrical characteristics

5.3.1.1 Rating

The rating conditions below apply to all pins.

5.3.1.1.1 Rated voltage

Rated voltage is 30V.

5.3.1.1.2 Rated current

Rated current is 1.0A for pins number 1 and 5, and 0.5A for pins number 2-4.

5.3.1.1.3 Insulation resistance

For insulation resistance refer to EIAJ standard RC-5239.

5.3.1.1.4 Withstand voltage

For withstand voltage refer to EIAJ standard RC-5239.

5.3.1.1.5 Contact resistance

For contact resistance refer to EIAJ standard RC-5239.

5.3.1.1.6 Contact capacitance

For contact capacitance refer to EIAJ standard RC-5239.

5.3.1.2 Signal characteristics

Below is the definition of the signal characteristics.

5.3.1.2.1 User signal for data communication

For signal characteristics of USB D+, USB D- and VBUS refer to USB Specification Revision 1.1. [1]

5.3.1.2.2 Clock signal for synchronous communication

Below is the definition of the signal characteristics.

Input characteristic:

Manufacturer specific pin is defined as CMOS input ($>200k\Omega$ input impedance).
The maximum voltage of the Manufacturer specific pin is 3.3 V.

Output characteristic:

CMOS output, $3V \pm 0.3V$.

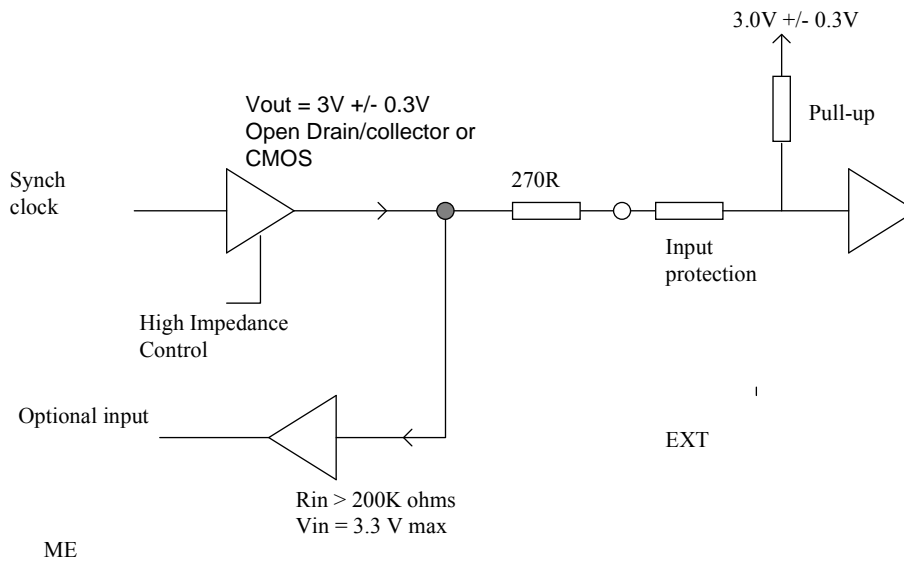

Figure 7: Output-input characteristics of the clock signal. (The input circuit is reference.)

5.4 Operating procedure

Below is the definition of the connector B operating procedure.

5.4.1 Clock signal for synchronous communication

This pin is defined to address the synchronisation between mobile equipment (ME) and the external equipment (EXT: TE etc) connected to each other via the external interface of the ME. In a mobile network there exist one master clock source, which provides the accurate frequency signal to all the equipment in the network. The ME can extract the accurate frequency signal from received RF signal. If an external equipment is connected to the ME via external interface, and if the synchronisation clock is provided from ME to EXT, the EXT can run with the clock. If an EXT and, for example, an ISDN terminal (or video viewer, G4 FAX, etc.) are connected, then the EXT can take the timing provided from the network.

5.4.1.1 Initial state

Initial state for clock signal is high impedance (> 200 kΩ).

5.4.1.2 Usage procedure

The synchronisation clock pin is defined as an output in response to message over USB channel. In this mode the pin outputs the synchronisation clock for real-time data transmission. The clock output can be disabled to return the synchronisation clock pin to its default state by a USB message.

When the Synchronisation Clock is provided from the ME to the EXT (e.g. an UD adapter), the triggering of the Synchronisation Clock shall be done using one of the below procedures.

1. If the EXT has a USB interface, and makes a request for the Synchronisation Clock, the EXT shall use USB message for the requesting procedure.
2. If the EXT has a USB interface, and makes no request for the Synchronisation Clock, the ME can activate the Synchronisation Clock without any request from the EXT. In this case the EXT shall detect the Synchronisation Clock signal sent from the ME.

3. If the EXT has no USB interface, the ME can activate the Synchronisation Clock without any request from the EXT. In this case the EXT shall detect the Synchronisation Clock signal sent from the ME.

In both procedures 1 and 2, the USB interface shall be able to function both with and without the Synchronisation Clock signal.

5.4.1.3 Connector release procedure

After the connector is disconnected, the Synchronisation clock pin must return to the high impedance State.

5.4.2 Manufacturer specific pin

The Synchronisation clock pin is bi-directional. The default state of the pin is input and in this mode the ME can sense the connection of external accessories. The identification can be analogue levels or a digital data code.

When an external accessory is detected the USB D+, USB D-, and VBUS signals can be released for non-USB applications (e.g. audio).

After the external accessory is disconnected, the Synchronisation clock pin must return to the high impedance State.

5.5 Physical conditions

5.5.1 Shape

For connector shape refer to EIAJ standard RC-5239.

5.5.2 Hot plug

The connector can be used for hot plug connection.

5.5.3 Dimensions

For connector dimensions refer to EIAJ standard RC-5239.

5.5.4 Tolerance

For connector tolerances refer to EIAJ standard RC-5239.

5.6 Physical strength characteristics

5.6.1 Insertion force

For insertion force refer to EIAJ standard RC-5239.

5.6.2 Durability

For durability refer to EIAJ standard RC-5239.

5.6.3 Vibration

For vibration refer to EIAJ standard RC-5239.

5.6.4 Shock resistance

For shock resistance refer to EIAJ standard RC-5239.

5.6.5 Locking strength

For locking strength refer to EIAJ standard RC-5239.

5.7 Climate resistance

5.7.1 Humidity resistance, steady state

For humidity (steady state) resistance refer to EIAJ standard RC-5239.

5.7.2 Thermal cycle characteristics

For thermal cycle characteristics refer to EIAJ standard RC-5239.

5.7.3 Dry heat resistance

For dry heat resistance refer to EIAJ standard RC-5239.

5.7.4 Cold resistance

For cold resistance refer to EIAJ standard RC-5239.

5.7.5 Salt water mist

For salt water mist resistance refer to EIAJ standard RC-5239.

5.7.6 Solder-heat resistance

For solder-heat resistance refer to EIAJ standard EIAJ RC-5239.

6. Connector C specification

6.1 Configuration

The Universal Serial Bus (USB) -based interface is specified for the electrical interface. The ME acts as a USB device. The USB-based electrical interface is compatible with PCs and it can connect to PCs directly. Furthermore, it is fast (12Mbps), and it has a multiplexed data transmission capability to support multi-media/multi-call services in IMT-2000 systems. Figure 8 shows the configuration of the USB-based interface. Between the ME and the TE, USB pipes are assigned for each service or for each call. Manufacturers and operators can use the USB vendor class for additional functions. For other functions, the USB Implementers Forum should define the new USB classes. For the connector's USB interface, JEITA standard RC-5242 is a normative reference.

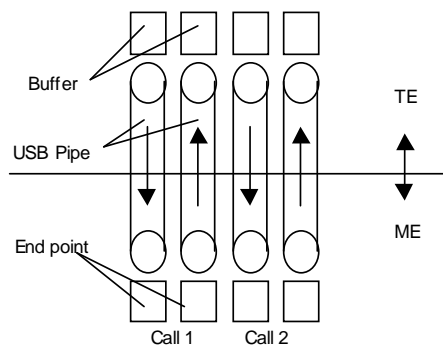

Figure 8: Configuration of the USB based interface.

6.1.1 Pin assignment

Table 3 and Figure 9 show the pin assignment of the Connector C. The specification of this connector is optional, and manufacturers can use other types of connectors. However, the rules and restrictions described in this section shall be applied when the connector specified by JEITA standard RC-5242 is used.

The pin assignment from No.1 to No.10 is compatible with the Connector A.

Table 3: Pin Assignment of Connector C

No	NAME	Direction		NOTE
		ME	EXT	
1	GND (USB GND)	---		
2	USB D+	<<<>>>		
3	USB D-	<<<>>>		
4	USB VBUS	<<<		
5	Power Supply	<<<		
6	Reserved	Reserved		Refer to 6.4.3 (Reserved for future power supply)
7	Synchronisation Clock	>>>		
8	Manufacturer Specific	<<<>>>		
9	Reserved	Reserved		Refer to 6.4.3
10	GND	---		
11	GND (Voice GND)	---		
12	MIC In	<<<		
13	EXT DET	<<<		
14	Audio Right	<<<>>>		
15	Audio Left	<<<>>>		
16	Stereo DET	<<<		
17	Power Out	>>>		
18	Switch DET	<<<		
19	Reserved 2	Reserved		Refer to 6.4.7
20	GND (Digital GND)	---		

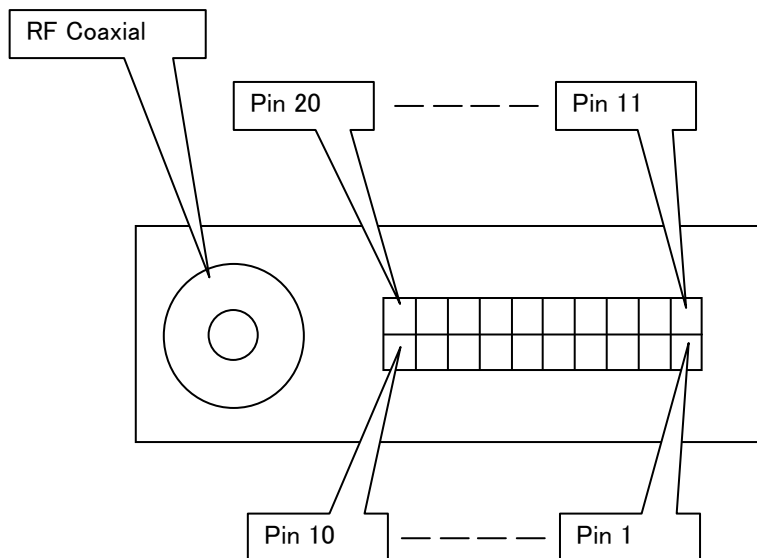

Figure 9: Pin Assignment of the Connector C (Receptacle).
(note: Connector mounted direction is not specified.)

6.1.2 Pin functions

The connector consists of twenty pins and one coaxial contact. It supports USB, power supply, clock, and RF input/output and HSJ (Head Set Jack) functions. The ME serves external equipment with a clock that synchronises with the transmission rate of the radio (air) interface. If external equipment (TE etc.) supports real-time applications, e.g., voice communication or ISDN, it can use the clock to synchronise the application’s clock synchronised with the data. For the power supply pin (5), the maximum voltage and maximum average current are specified. External equipment

(TE etc.) that supplies the ME with power must not supply the voltage over the specified maximum voltage, and it must limit the current to the specified maximum average current. The ME can select/limit the external equipment by means of logical negotiation through the manufacturer specific pin (8). For example, manufacturers can limit the range of supplied voltage by selecting the power adapters to be connected to the ME. The pins (6,9,19) are the reserved pins, and the manufacturer can not use the pins (6,9,19) freely. After the negotiation is successfully completed, all pins can be used without restraint. When the supplied voltage through the pin (4) is below a USB VBUS voltage specified in “Universal Serial Bus Specification Revision 1.1” [1](USB Implementers Forum), the ME may act as a non-USB device. In this case, The ME can change the pins function temporarily except the pins (1,5,10,11,20).

6.2 Operating environmental conditions

6.2.1 Temperature condition

For temperature conditions refer to JEITA standard RC-5242.

6.2.2 Humidity condition

For humidity conditions refer to JEITA standard RC-5242.

6.3 Technical requirements

Below is the definition of the connector C technical requirements.

6.3.1 Frequency range

The radio frequency range for RF TRX pin is 1.92GHz to 2.17GHz.

6.3.2 Electrical characteristics

6.3.2.1 Rating

The rating conditions below apply to all pins except to the RF TRX pin.

6.3.2.1.1 Rated voltage

Rated voltage is 30V.

6.3.2.1.2 Rated current

Rated current is 0.5A for 2,3,4,7,8,9,12,13,14,15,16,17,18,19pins and 1.0A for 1,5,6,10,11,20pins

6.3.2.1.3 Insulation resistance

For insulation resistance refer to JEITA standard RC-5242.

6.3.2.1.4 Withstand voltage

For withstand voltage refer to JEITA standard RC-5242.

6.3.2.1.5 Contact resistance

For contact resistance refer to JEITA standard RC-5242.

6.3.2.1.6 Contact capacitance

For contact capacitance refer to JEITA standard RC-5242.

6.3.2.2 Signal characteristics

Below is the definition of the signal characteristics.

6.3.2.2.1 User signal for data communication

For signal characteristics of USB D+, USB D- and USB VBUS refer to “Universal Serial Bus Specification Revision 1.1” [1](USB Implementers Forum).

6.3.2.2.2 Clock signal for synchronous communication

Below is the definition of the synchronisation clock pin.

Electrical condition :CMOS 3V ± 0.3V.High impedance at unused time.(> 200 kΩ)

Frequency: 64kHz (duty=1:1)

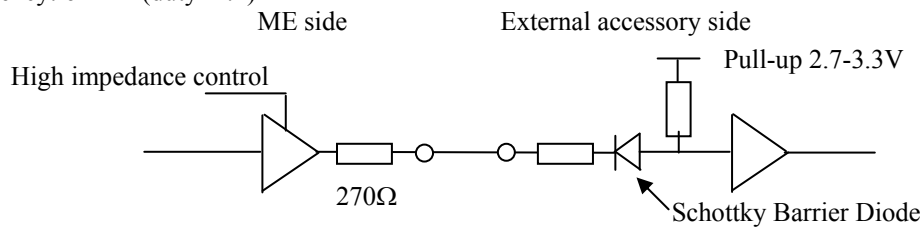

Figure 10: Output-input characteristics of the clock signal. (The input circuit is reference.)

6.3.2.2.3 Manufacturer specific pin

Below is the definition of the Manufacturer specific pin.

High impedance at unused time.(> 200 kΩ)

The maximum voltage of the Manufacturer specific pin is limited to less than 3.6 V.

6.3.2.2.4 Reserved pin

Below is the definition of the Reserved pins.

High impedance at unused time.(> 200 kΩ)

The maximum voltage of the Reserved pins is limited to less than 3.6 V.

6.3.2.2.5 MIC In pin

Below is the definition of the MIC In pin.

The reference voltage of the MIC In pin is 2V with 2.2kΩ bias.

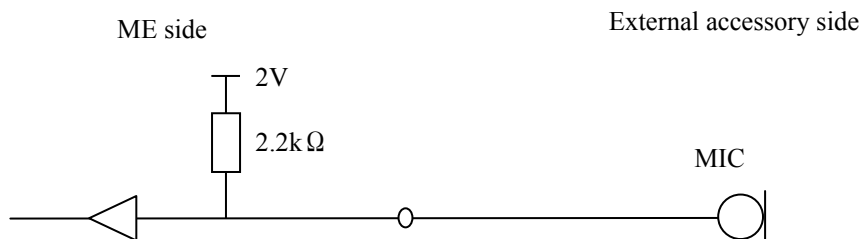

Figure 11: Electric characteristics of the MIC In pin.

6.3.2.2.6 EXT DET pin

Below is the definition of the EXT DET pin.

The EXT DET pin is pulled-up in ME.

6.3.2.2.7 Audio Right / Left pin

Below is the definition of the Audio Right / Left pin.

When these pins are used as Earphone Out, load impedance is $32\ \Omega$.

When these pins are used as Voice In / Out, the maximum voltage is $2V_{rms}$ and the maximum load impedance is $22k\ \Omega$.

These pins must be AC coupled in ME.

6.3.2.2.8 Stereo DET pin

Below is the definition of the Stereo DET pin.

The Stereo DET pin is pulled-up in ME.

6.3.2.2.9 Power Out pin

Below is the definition of the Power Out pin.

The voltage of the Power Out pin is $3 \pm 0.3V$.

6.3.2.2.10 Switch DET pin

Below is the definition of the Switch DET pin.

The input voltage of high level is $0.8V_{DD} \sim V_{DD}$.

The input voltage of low level is $0 \sim 0.2V_{DD}$.

V_{DD} is $3 \pm 0.3V$.

6.3.2.2.11 Reserved 2 pin

Below is the definition of the Reserved 2 pins.

High impedance at unused time. ($> 200\ k\Omega$)

6.3.3 RF line characteristics

Below is the definition of the RF TRX pin.

6.3.3.1 Maximum input power

Maximum input power is less than $2W$.

6.3.3.2 Impedance

Impedance is 50Ω . (Nominally)

6.3.3.3 Insertion loss

Insertion loss is less than 0.5dB.

6.3.3.4 VSWR

VSWR is less than 1.5.

6.4 Operating procedure

Below defines the connector A operating procedure.

6.4.1 Clock signal for synchronous communication

This pin is defined to address the synchronisation between mobile equipment (ME) and the external equipment (EXT: TE etc) connected to each other via the external interface of the ME. In a mobile network there exist one master clock source, which provides the accurate frequency signal to all the equipment in the network. The ME can extract the accurate frequency signal from received RF signal. If an external equipment is connected to the ME via external interface, and if the synchronisation clock is provided from ME to EXT, the EXT can run with the clock. If an EXT and, for example, an ISDN terminal (or video viewer, G4 FAX, etc.) are connected, then the EXT can take the timing provided from the network.

6.4.1.1 Initial state

Below defines the initial state.

ME: High impedance or No-connection (not in use)

EXT(peripheral): High impedance or No-connection (not in use)

6.4.1.2 Usage procedure

When the Synchronisation Clock is provided from the ME to the EXT (e.g. an UD adapter), the triggering of the Synchronisation Clock shall be done using one of the three procedures below:

1. If the EXT has a USB interface, and makes a request for the Synchronisation Clock, the EXT shall use USB message for the requesting procedure.
2. If the EXT has a USB interface, and makes no request for the Synchronisation Clock, the ME can activate the Synchronisation Clock without any request from the EXT. In this case the EXT shall detect the Synchronisation Clock signal sent from the ME.
3. If the EXT has no USB interface, the ME can activate the Synchronisation Clock without any request from the EXT. In this case the EXT shall detect the Synchronisation Clock signal sent from the ME.

In both procedures 1 and 2, the USB interface shall be able to function both with and without the Synchronisation Clock signal.

6.4.1.3 Connector release procedure

After the connector is disconnected, the Synchronisation clock pin must return to the high impedance state in the ME.

6.4.2 Manufacturer specific pin

Each manufacturer defines this pin and the main foreseen functions that the pin takes are:

- To recognise the external terminal ID.
- To distinguish and to authenticate the connecting charger use safety or not safety.
- To change the pins function temporarily.

6.4.2.1 Initial state

ME: High impedance or No-connection (not in use)

EXT(peripheral): High impedance or No-connection (not in use)

6.4.2.2 Usage procedure

The identification can be analogue levels or it can be digital data code.

6.4.2.3 Connector release procedure

After the connector is disconnected, the manufacturer specific pin must return to the high impedance state in the ME.

6.4.3 Reserved pin

These pins are defined for future uses.

If pins function change with manufacturer specific pin, these reserved pins by definition can be used for any manufacturer specific function.

6.4.3.1 Initial state

ME: High impedance or No-connection (not in use)

EXT(peripheral): High impedance or No-connection (not in use)

6.4.3.2 Connector release procedure

After the connector is disconnected, the reserved pins must return to the high impedance state in the ME.

6.4.4 EXT DET pin

This pin is defined to detect external equipment.

6.4.4.1 Initial state

ME: Pull-up

EXT(peripheral): GND

6.4.4.2 Usage procedure

When the connector is connected, the level of the EXT DET pin must be Low level.

6.4.4.3 Connector release procedure

After the connector is disconnected, the level of the EXT DET pin must return to High level.

6.4.5 Stereo DET pin

This pin is defined to detect stereo type external equipment.

6.4.5.1 Initial state

ME: Pull-up

EXT(peripheral):

Stereo type: GND

Monaural type: High impedance or No-connection (not in use).

6.4.5.2 Usage procedure

When the stereo type external equipment is connected, the level of the Stereo DET pin must be Low level. On the other hand, when the monaural type external equipment is connected, the level of the Stereo DET pin must remain High level.

6.4.5.3 Connector release procedure

After the stereo type external equipment is disconnected, the level of the Stereo DET pin must return to High level.

6.4.6 Switch DET pin

This pin is defined to detect the state of Head Set Switch.

6.4.6.1 Initial state

ME: Pull-up

EXT(peripheral): High impedance or No-connection (not in use)

6.4.6.2 Usage procedure

When the Head Set Switch of the external equipment is OFF, the input level to the Switch DET pin must remain High level.

On the other hand, when the Head Set Switch of the external equipment is ON, the input level to the Switch DET pin must be Low level.

6.4.6.3 Connector release procedure

After the connector is disconnected, the level of the Switch DET pin must return to High level.

6.4.7 Reserved 2 pin

This pin is defined for future uses.

If pin function changes with manufacturer specific pin, this reserved pin by definition can be used for any manufacturer specific function.

6.4.7.1 Initial state

ME: High impedance or No-connection (not in use)

EXT(peripheral): High impedance or No-connection (not in use)

6.4.7.2 Connector release procedure

After the connector is disconnected, the reserved 2 pin must return to the high impedance state in the ME.

6.5 Physical conditions

6.5.1 Shape

For connector shape refer to JEITA standard RC-5242.

6.5.2 Hot plug

The connector can be used for hot plug connection.

6.5.3 Dimensions

For connector dimensions refer to JEITA standard RC-5242.

6.5.4 Tolerance

For connector tolerance refer to JEITA standard RC-5242.

6.6 Physical strength characteristics

6.6.1 Insertion force and extraction force

For insertion force and extraction force refer to JEITA standard RC-5242.

6.6.2 Durability

For durability refer to JEITA standard RC-5242.

6.6.3 Vibration

For vibration refer to JEITA standard RC-5242.

6.6.4 Shock resistance

For shock resistance refer to JEITA standard RC-5242.

6.6.5 Locking strength

For locking strength refer to JEITA standard RC-5242.

6.7 Climate resistance

6.7.1 Humidity resistance, steady state

For humidity resistance refer to JEITA standard RC-5242.

6.7.2 Thermal cycle characteristics

For thermal cycle characteristics refer to JEITA standard RC-5242.

6.7.3 Dry heat resistance

For dry heat resistance refer to JEITA standard RC-5242.

6.7.4 Cold resistance

For cold resistance refer to JEITA standard RC-5242.

6.7.5 Salt water mist

For salt water mist refer to JEITA standard RC-5242.

6.7.6 Solder-heat resistance

For solder-heat resistance refer to JEITA standard RC-5242.

Annex A: Power supply line (charge) characteristics - Connector A and Connector C

The signal characteristics below apply to power supply lines.

The power supply line (pin No 5) is used for charging the battery attached to the ME. To prevent from the electric destruction of the ME's circuitry, the maximum voltage of the power supply is 6 V.

Annex B: Connector release procedure

Set default pin function. (Set high impedance and keep status in the ME.)

Annex C: Change history

Change history		
New version	Date	Subject/Comments
3.0.1	Nov. 8th. 2000	One of power supply pin (6) was changed to reserved pin.
3.2.0	Sep. 26th.2007	'6 Connector C specification' was added. Action as a non -USB device was added to '4.1.2 PIN functions'.
3.3.0	Sep. 25th.2008	The standard number [T.B.D] was changed to 'JEITA standard RC-5242'.

History

Document history		
0.0.1	Nov. 17th. 1999	First draft created at ARIB 3GPP-T2-WG-a 7th meeting Tokyo.
0.0.2	Nov. 24th. 1999	New version presented at ARIB 3GPP-T2-WG-a 8th meeting Tokyo.
0.0.3	Dec. 1st. 1999	New version presented at ARIB 3GPP-T2-WG-a 9th meeting Tokyo.
0.1.0	Dec. 8th. 1999	English version presented at ARIB 3GPP-T2-WG-a 10th meeting Tokyo.
0.1.2	Dec. 15th. 1999	English version presented at ARIB 3GPP-T2-WG-a 11th meeting Tokyo.
0.1.3	Dec. 17th. 1999	English version mailed by e-mail.
0.1.4	Dec. 20th. 1999	Final draft mailed by e-mail.
1.0.0	Dec. 21st. 1999	Formal version presented at ARIB 3GPP-T2-WG-a 12th meeting Tokyo.
1.0.1	Jan. 25th. 2000	Formal version presented at ARIB 3GPP-T2-Ad hoc 15th meeting Tokyo.
2.0.0	Jan. 25th. 2000	Approved at ARIB 3GPP-T2-Adohoc 15th meeting Tokyo.
3.0.0	Jan. 27th. 2000	Approved at ARIB 3GPP-T 9th meeting Tokyo.
3.0.1	Nov. 8th. 2000	Formal version presented at ARIB 3GPP-T2-WG-a 14th meeting Tokyo.
3.0.1	Nov. 17th. 2000	Approved at ARIB 3GPP-T2-WG-a by e-mail.
3.0.1	Dec. 4th. 2000	Approved at ARIB 3GPP-T 13th meeting Tokyo.
3.1.0	Dec. 21st. 2000	Approved at ARIB ISD 13th meeting Tokyo.
3.2.0	Sep. 26th. 2007	Revised by the 67th ARIB Standard Assembly.
3.3.0	Sep. 25th. 2008	Revised by the 71st ARIB Standard Assembly.