

E680/E680i

Revision Overview	
Rev. 1.0: Initial Block Diagram	
Rev. 1.1: updated Table on page 3	
Rev. 1.2: add productname E680i	

GSM SERVICE SUPPORT GROUP	2005.03.18
LEVEL 3 AL Block Diagram	Rev. 1.2
E680/ E680i	
Michael Mauderer, Alexander Buehler	Page 2of 3

Pin Number	Normal USB Acc.	Factory Test & Flash	High Voltage Flash	Mono Accessory	Stereo Accessory	Dumb PPD *3	Dumb Mid-Rate Charger (500mA)	Dumb Fast Charger (1,25A)	Battery Powered	Software Regression Testing	MPx Mid-Rate Charger (450mA)	MPx Dual-Rate VPA (450/850mA)	SIHF CarKit
1	VBUS	VBUS	VBUS	Phone PPD Level	Phone PPD Level	Phone PPD Level	5V	5V	VBUS	VBUS	5V	5V	
2	DM_TXD	DM_TXD	DM_TXD	HJACK_SPKR_L	HJACK_SPKR_L	DM_TXD	Short to DP_RXD	Short to DP_RXD	DM_TXD	DM_TXD	DP_RXD	DP_RXD	
3	DP_RXD	DP_RXD	DP_RXD	AUDIO_IN	HJACK_SPKR_R	DP_RXD	Short to DM_TXD	Short to DM_TXD	DP_RXD	DP_RXD	DM_TXD	DM_TXD	
4 (ID)	Open (2,8V)	4,75-5,25 *1, 3,0-3,3V *2	Open (2,8V)	102 K Ohm +/- 1%	102 K Ohm +/- 1%	102 K Ohm +/- 1%	200 KOhm +/- 1%	440 KOhm +/- 1%	440 KOhm +/- 1% (Powers on the phone)	200 KOhm +/- 1%	100KOhm +/- 1%	10 KOhm +/- 1%	
5	GND	GND	GND	GND	GND	GND	GND	GND	GND	GND	GND	GND	
Shield	GND	GND	GND	GND	GND	GND	GND	GND	GND	GND	GND	GND	
	SW												
Signal Name													
USB_ID	Open (2,4V)	5V	9V	Open (2,4V)	Open (2,4V)	0V	1,225V	1,68V	1,68V	1,225V	0,82V	0,1V	
AD6	2,4V	3,4V	3,5V	2,4V	2,4V	0V	1,225V	1,68V	1,68V	1,225V	0,825V	0,1V	
PPD_DET	High	High	High	High	High	Low	High	High	High	High	Low	Low	
SMP_INT	High	High	High	High	High	Low	High	High	High	High	High	Low	
FACT_DET	Low	High	Low	Low	Low	Low	Low	Low	Low	Low	Low	Low	
CHRG_DET	Low	High	Low	Low	Low	Low	High	High	Low	Low	High	High	
MUX1	Low	Low	Low	High	High	Low	Low	Low	Low	Low	Low	Low	
MUX2	Low	Low	Low	Low	High	Low	Low	Low	Low	Low	Low	Low	
CHRG_DET_PU	High	Low	Low	Low	Low	Low	Low	Low	Low	Low	Low	Low	
USB_EN	Low	Low	Low	Low	Low	Low	Low	Low	Low	Low	Low	Low	
USB_PWR	High	High	High	High	High	High	High	High	High	High	High	High	
USB_VBUS	5V	5V	5V	Phone PPD Level	Phone PPD Level	Phone PPD Level	5V	5V	5V	5V	5V	5V	
SNP_INT_CTL	High	High	High	High	High	High	High	High	High	High	High	High	

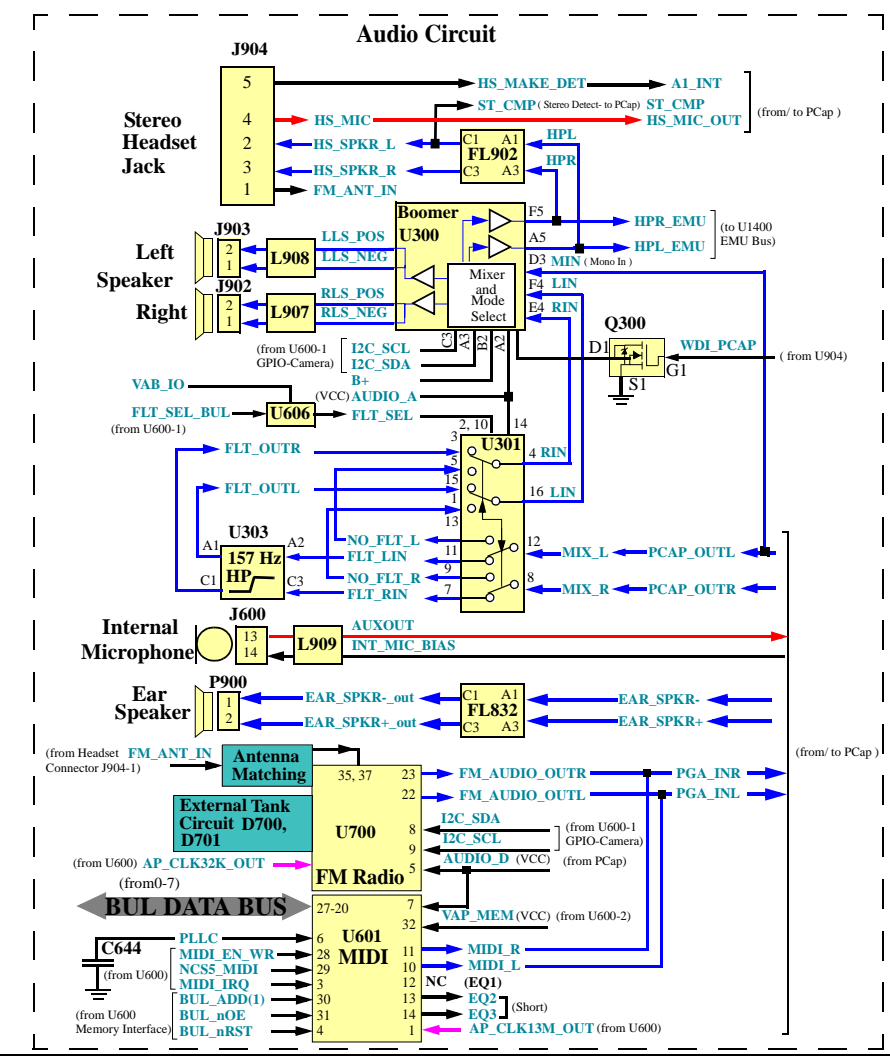
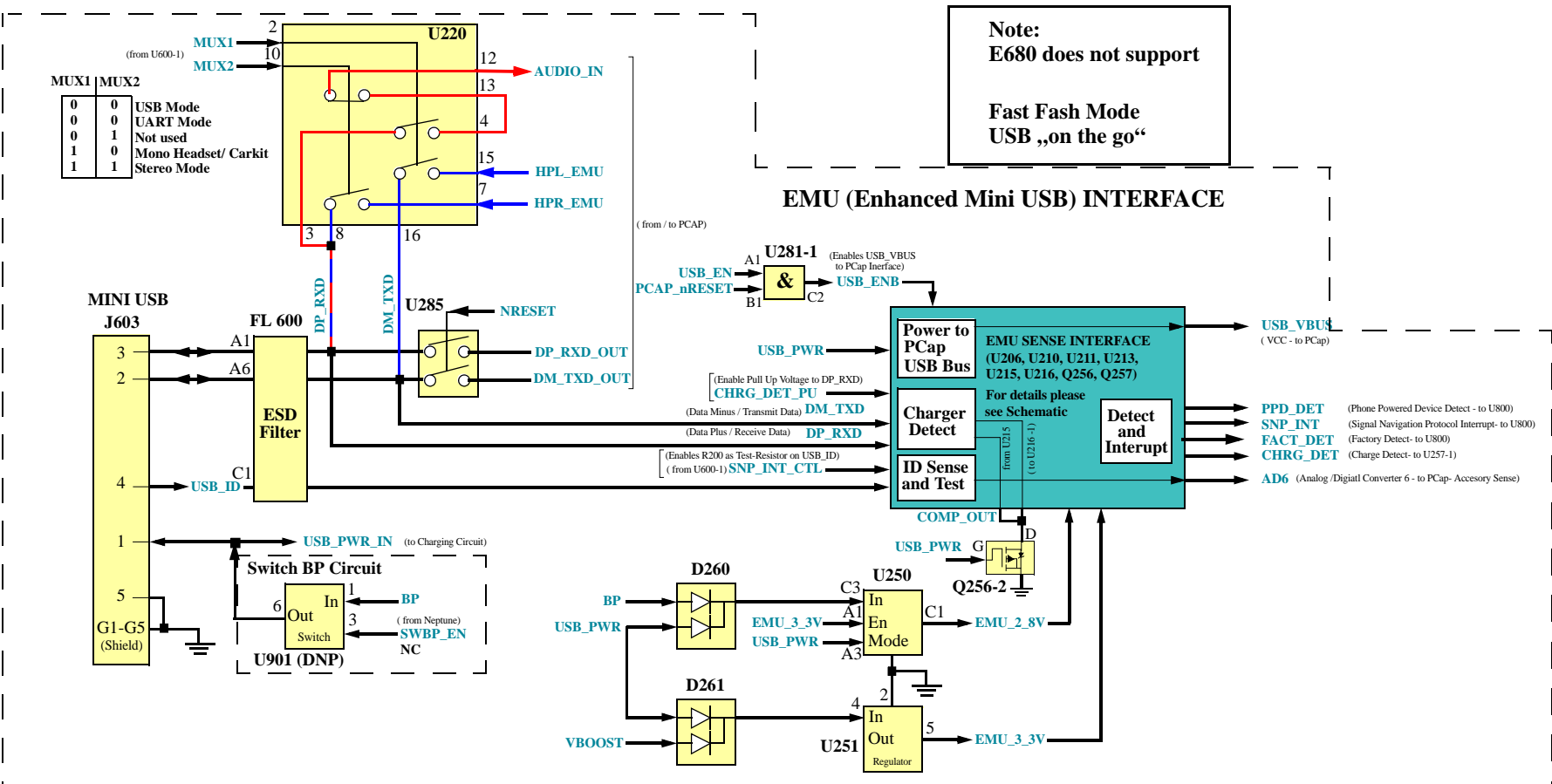

E680/E680i

GSM SERVICE SUPPORT GROUP	2005.03.18
LEVEL 3 AL Block Diagram	Rev. 1.2
E680/ E680i	
Michael Mauderer, Alexander Buehler	Page 3of 3

Revision Overview
Rev. 1.0: Initial Block Diagram
Rev. 1.1: updated Table on page 3
Rev. 1.2: add productname E680i