



**MOTOROLA**

# Level 1 and 2 Service Manual

68000201686-A

## AURA™ R1



GSM 850/900/1800/1900 MHz EDGE, GPRS

MOTOROLA and the Stylized M Logo are registered in the US Patent & Trademark Office.  
All other product or service names are the property of their respective owners.

The Bluetooth trademarks are owned by their proprietor and used by Motorola, Inc. under license.  
© Motorola, Inc. 2008.  
All rights reserved.

Mobile Devices Business,  
8000 West Sunrise Boulevard  
Mail drop 42-16A  
Plantation, Florida 33322-9947  
USA

# Contents

<b>Introduction</b> .....	<b>5</b>
Product Identification .....	5
Product Names .....	5
Product Changes .....	5
Regulatory Agency Compliance .....	5
Computer Program Copyrights .....	6
About this Service Manual .....	6
Warranty Service Policy .....	7
Parts Replacement .....	7
<b>Specifications</b> .....	<b>9</b>
<b>Product Overview</b> .....	<b>11</b>
Features .....	11
<b>General Operation</b> .....	<b>13</b>
Controls, Indicators, and Input / Output (I/O) Connections .....	13
Battery Function .....	16
Operation .....	16
<b>Tools and Test Equipment</b> .....	<b>17</b>
<b>Disassembly/Reassembly</b> .....	<b>18</b>
Removing and Replacing the Battery Cover and Battery .....	18
Removing and Replacing the Subscriber Identity Module (SIM) .....	19
Transceiver Disassembly .....	21
Blade Disassembly .....	31
Blade Disassembly Without Disassembly of the Transceiver .....	34
Assembling the Blade Assembly .....	36
Transceiver Assembly .....	58
<b>Subscriber Identity Module (SIM) and Identification</b> .....	<b>91</b>
SIM Card .....	91
Personality Transfer .....	91
Identification .....	91
<b>Troubleshooting</b> .....	<b>93</b>
Manual Test Mode .....	93
Manual Test Mode Commands .....	93
Programming: Software Upgrade and Flexing .....	94
Part Numbers .....	94
Exploded View Diagram .....	95
Exploded View Parts List .....	96
<b>INDEX</b> .....	<b>INDEX-1</b>



## Introduction

Motorola® Inc. maintains a worldwide organization that is dedicated to provide responsive, full-service customer support. Motorola products are serviced by an international network of company-operated product-care centers as well as authorized independent service firms.

Available on a contract basis, Motorola Inc. offers comprehensive maintenance and installation programs that allow customers to meet requirements for reliable, continuous communications.

To learn more about the wide range of Motorola service programs, contact your local Motorola products representative or the nearest Customer Service Manager.

## Product Identification

Motorola products are identified by the model number on a label usually located under the battery. Use the entire model number when inquiring about the product. Numbers are also assigned to chassis and kits. Use these numbers when requesting information or ordering replacement parts.

## Product Names

Product names are listed on the front cover. Product names are subject to change without notice. Some product names, as well as some frequency bands, are available only in certain markets.

## Product Changes

When electrical, mechanical or production changes are incorporated into Motorola products, a revision letter is assigned to the chassis or kit affected, for example; -A, -B, or -C, and so on.

The chassis or kit number, complete with revision number, is imprinted during production. The revision letter is an integral part of the chassis or kit number and is also listed on schematic diagrams and printed-circuit board layouts.

## Regulatory Agency Compliance

This device complies with Part 15 of the FCC Rules. Operation is subject to the following conditions:

- This device may not cause any harmful interference
- This device must accept interference received, including interference that may cause undesired operation

This class B device also complies with all requirements of the Canadian Interference-Causing Equipment Regulations (ICES-003).

Cet appareil numérique de la classe B respecte toutes les exigences du Règlement sur le matériel brouilleur du Canada.

---

## Computer Program Copyrights

The Motorola products described in this manual may include Motorola computer programs stored in semiconductor memories or other media that are copyrighted with all rights reserved worldwide to Motorola. Laws in the United States and other countries preserve for Motorola, Inc. certain exclusive rights to the copyrighted computer programs, including the exclusive right to copy, reproduce, modify, decompile, disassemble, and reverse-engineer the Motorola computer programs in any manner or form without Motorola's prior written consent. Furthermore, the purchase of Motorola products shall not be deemed to grant either directly or by implication, estoppel, or otherwise, any license or rights under the copyrights, patents, or patent applications of Motorola, except for a nonexclusive license to use the Motorola product and the Motorola computer programs with the Motorola product.

## About this Service Manual

Using this service manual and the suggestions contained in it assures proper installation, operation, and maintenance. Refer questions about this manual to the nearest Customer Service Manager. Table 1 shows the revision history of this service manual.

**Table 1. Manual Revision History**

Revision	Issue Date	Description
A	December 31, 2008	Initial Release

### Audience

Service personnel should be familiar with electronic assembly, testing, and troubleshooting methods, and with the operation and use of associated test equipment.

### Scope

This manual aids service personnel in testing and repairing specific Motorola wireless phones. This manual includes procedures and processes for repairing the phones at Level 1 and 2 service centers including:

- Unit swap out
- Repairing of mechanical faults
- Basic modular troubleshooting
- Testing and verification of unit functionality
- Initiate warranty claims and send faulty modules to Level 3 or 4 repair centers

---

## Conventions

The following special characters and typefaces, are used in this manual to emphasize certain types of information.



*Note: Emphasizes additional information pertinent to the subject matter.*



*Caution: Emphasizes information about actions which may result in equipment damage.*



*Warning: Emphasizes information about actions which may result in personal injury.*

## Warranty Service Policy

The product is sold with the standard 12-month warranty terms and conditions. Accidental damage, misuse, and extended warranties offered by retailers are not supported under warranty. Non-warranty repairs are available at agreed fixed repair prices.

### Out-of-Box Failure Policy

The standard out-of-box failure criteria applies. Return customer units that fail very early on after the date of sale to Manufacturing for root cause analysis, to guard against epidemic criteria. Manufacturing to bear the costs of early life failure.

### Product Support

Customer's original units will be repaired but not refurbished as standard. Appointed Motorola Service Hubs will perform warranty and non-warranty field service for level 2 (assemblies) and level 3 (limited PCB component). Motorola High Tech Centers will perform level-4 (full component) repairs.

### Customer Support

Customer support is available through dedicated Call Centers and in-country help desks. Product Service training is available through the local Motorola Support Center.

## Parts Replacement

When ordering replacement parts or equipment, include the Motorola part number and description used in the service manual.

When the Motorola part number of a component is not known, use the product model number or other related major assembly along with a description of the related major assembly and of the component in question.

---

## Replacement Parts Service Division (RPSD)

Order replacement parts, test equipment, and manuals from RPSD.

### U.S.A.

Phone: 800-422-4210

FAX: 800-622-6210

Website: <http://businessonline.motorola.com>

### Outside U.S.A.

Phone: 847-538-8023

FAX: 847-576-3023

### EMEA

Phone: +49 461 803 1404

Website: <http://emeaonline.motorola.com>

### Asia

Phone: +65 648 62995

Website: <http://asiaonline.motorola.com>



## Specifications

General Function	Specification
Frequency Range GSM 850	824-848 MHz Tx 869-893 MHz Rx
Frequency Range GSM 900	880-915 MHz Tx (with EGSM) 925-960 MHz Rx
Frequency Range DCS 1800	1710-1785 MHz Tx 1805-1880 MHz Rx
Frequency Range PCS 1900	1850-1910 MHz Tx 1930-1990 MHz Rx
Channel Spacing	200 kHz
Channels	174 EGSM, 374 DCS, 374 PCS, 124 GSM 850 carriers with 8 channels per carrier
Modulation	GMSK at BT = 0.3
Transmitter Phase Accuracy	5 Degrees RMS, 20 Degrees peak
Duplex Spacing	45 MHz
Frequency Stability	± 0.10 ppm of the downlink frequency (Rx)
Operating Voltage	+3.2V dc to +5.5V dc (battery) +4.8V dc to +6.5V dc (external connector)
Transmit Current Drain	101-260 mA average talk current drain
Stand-by Current drain	5 mA (DRX2), 2 mA (DXR9) typical
Temperature Range	-10° C to +55° C (+15° F to +130° F)
Dimensions (xyz)	47mm x 96mm x 15mm
Size (Volume)	60 cc
Weight	155 grams with battery
Battery Life, with standard 950 mAh Li-Ion Battery	Talk Time up to 180-360 minutes Standby time up to 160-300 hours  All talk and standby times are approximate and depend on network configuration, signal strength, and features selected. Standby times are quoted as a range from DRX=2 to DRX=9. Talk times are quoted as a range from DTX off to DTX on.
Battery Charge Time	4 hours to 90% of 950 mAh capacity
Alert volume	Max 95 dB @5cm, 0.5 Watts input

Transmitter Function	Specification
RF Power Output	32 dBm nominal GSM 850/900, 29 dBm nominal GSM 1800/1900
Output Impedance	50 ohms nominal
Spurious Emissions	-36 dBm from 0.1 to 1 GHz, -30 dBm from 1 to 4 GHz

Receiver Function	Specification
Receive Sensitivity	Better than -103 dBm
RX Bit Error Rate (100k bits) Type II	< 2%

Speech Coding Function	Specification
Speech Coding Type	Regular pulse excitation/linear predictive coding with long term prediction (RPE LPC with LTP)
Bit Rate	13.0 kbps
Frame Duration	20 ms

---

Speech Coding Function	Specification
Block Length	260 bits
Classes	Class 1 bits = 182 bits; Class 2 bits = 78 bits
Bit Rate with FEC Encoding	22.8 kbps

---

## Product Overview

The **Aura R1** by Motorola represents a new dimension of design and function, and an exclusive example of fine quality craftsmanship, attention to detail, premium materials and unique design in this global system for mobile communications (GSM) general packet radio service (GPRS) wireless application protocol (WAP)-enabled mobile device.

The Aura R1 is a quad-band device that allows roaming within the GSM 900 MHz, GSM 850 MHz, 1800 MHz digital cellular system (DCS), and 1900 MHz PCS bands.

Aura R1 support GPRS and Enhanced Data rates for GSM Evolution (EDGE).

The Aura R1 is a 180° rotator form factor design, with a full stainless steel metal housing and equipped with a round 1.55" liquid crystal display (LCD), with 480 pixels across and capable of up to 16M colors, which provides the highest resolution possible on mobile devices. The display is covered by a one piece 68-carat scratch-resistant domed sapphire crystal lens, which hardness is second only to diamonds.

This device consists of the main housing assembly and rotator mechanism.

The main housing contains the battery, battery cover, charging connector, main circuit board, chassis, keypad, and internal antenna. The round high resolution display, control keys, and keypad are located on the front of the device. The camera, battery compartment are located at the rear of the device. The standard 950 mAh Lithium Ion (Li Ion) battery fits behind a removable cover and provides up to 360 minutes of talk time with up to 300 hours of standby time<sup>1</sup>. The display module consists of a 480 pixel wide high resolution display.

The camera module is a 2.0 mega pixel CMOS camera.

The phone accepts both 3V and 1.8V mini subscriber identity module (SIM) cards which fit into the SIM holder next to the battery. The antenna is mounted internally. Direct connection to a computer or handheld device provided by USB or Bluetooth® for data and fax calls, and for synchronizing phonebook entries with Mobile Phone Tools software, can be accomplished by using the optional data cable and soft modem.

## Features

Aura R1 phones use advanced, self-contained, sealed, custom integrated circuits to perform the complex functions required for GSM communication. Aside from the space and weight advantage, microcircuits enhance basic reliability, simplify maintenance, and provide a wide variety of operational functions.

Features available in this model include:

- Messaging: MMS, EMS 5.0, IM Wireless Village, Email (POP3, SMTP, IMAP4)
- Music: MIDI, MP3, AAC, AAC+, Enhanced AAC+, WMA, WAV, AMR-NB, Real Audio (RA) v10
- Video: capture and playback
- Camera: 2MP with 8x zoom on capture; video capture & playback
- Memory: 2GB internal memory, microSD external memory (up to 8GB)
- Stereo Bluetooth® Class 2 (A2DP),
- USB 2.0 Hi-speed
- GPRS Class 12, EDGE Class 12

---

1. All talk and standby times are approximate and depend on network configuration, signal strength, and features selected.

- Over the air synchronization

### **Wireless Access Protocol (WAP) 2.0 Compliancy**

In the WAP environment, access to the Internet is initiated in wireless markup language (WML), which is derived from hypertext markup language (HTML). The request is passed to a WAP gateway that retrieves the information from the server in standard HTML (subsequently filtered to WML) or directly in WML if available. The information is then passed to the mobile subscriber via the mobile network.

The EM30 microbrowser can be configured for baud, idle timeout, line type, phone number, and connection type.



*Bitmap image data will download as text. If the image is larger than the screen, only part of the image will display.*



*When the user receives a call while in browser mode, the browser will pause and allow the user to resume after completing the call.*

### **Other Features**

Detailed descriptions of these and other Aura R1 features can be found in the user's guide.

---

## General Operation

### Controls, Indicators, and Input / Output (I/O) Connections

Aura R1 controls are located on the sides and rear of the phone. See Figures 2 and 2.

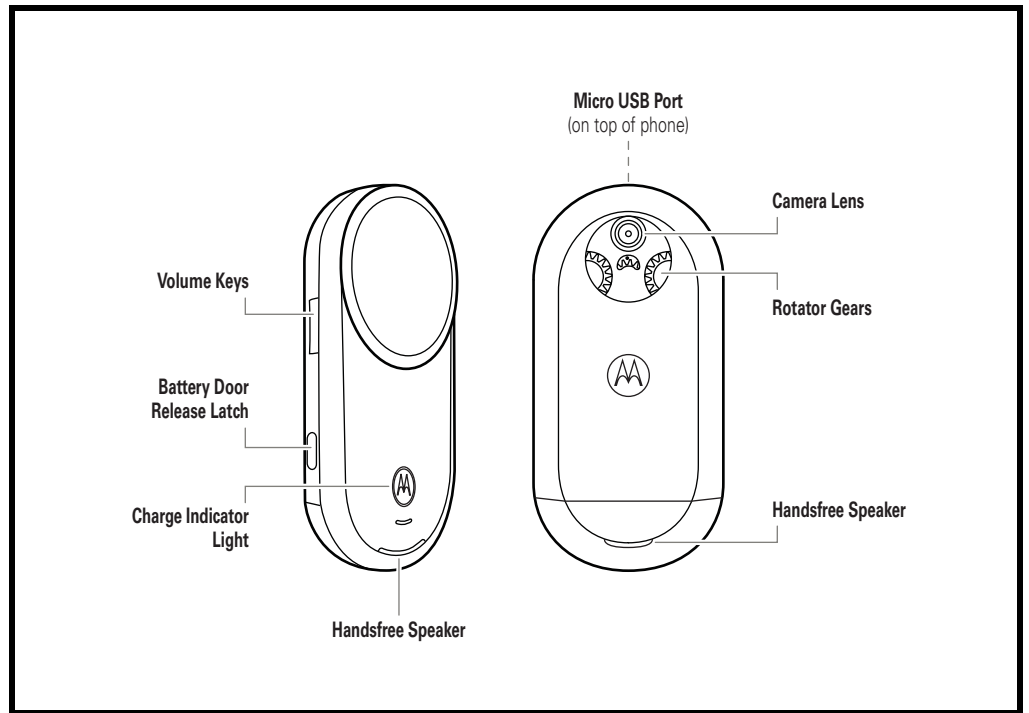

v558619

**Figure 1. Controls, indicators, and I/O**

The phone's charging indicator earpiece speaker are at the front, the camera lens, handsfree speaker, and rotator gears are located on the back. The volume keys and the battery door latch are located on side. The phone has a micro USB port, located on the top of the phone.

When the rotator is open, the keypad keys provide additional functionality. The center key opens the initial menu structure, or allows access to a submenu.

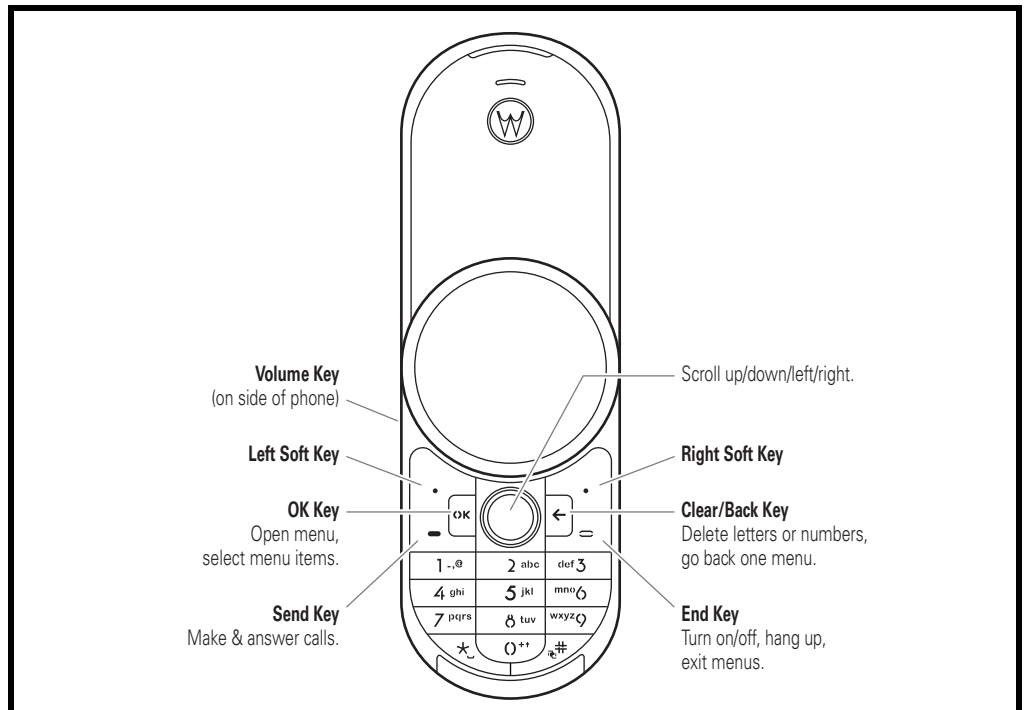

v558619

**Figure 2. Additional Controls, indicators, and I/O**

**Display**

The Aura R1 wireless phone features 1.55 inch high resolution 480 pixel diameter display.

Indicators, in the form of icons, display on the LCD. Figure 3 shows some of the icons that display on the LCD.

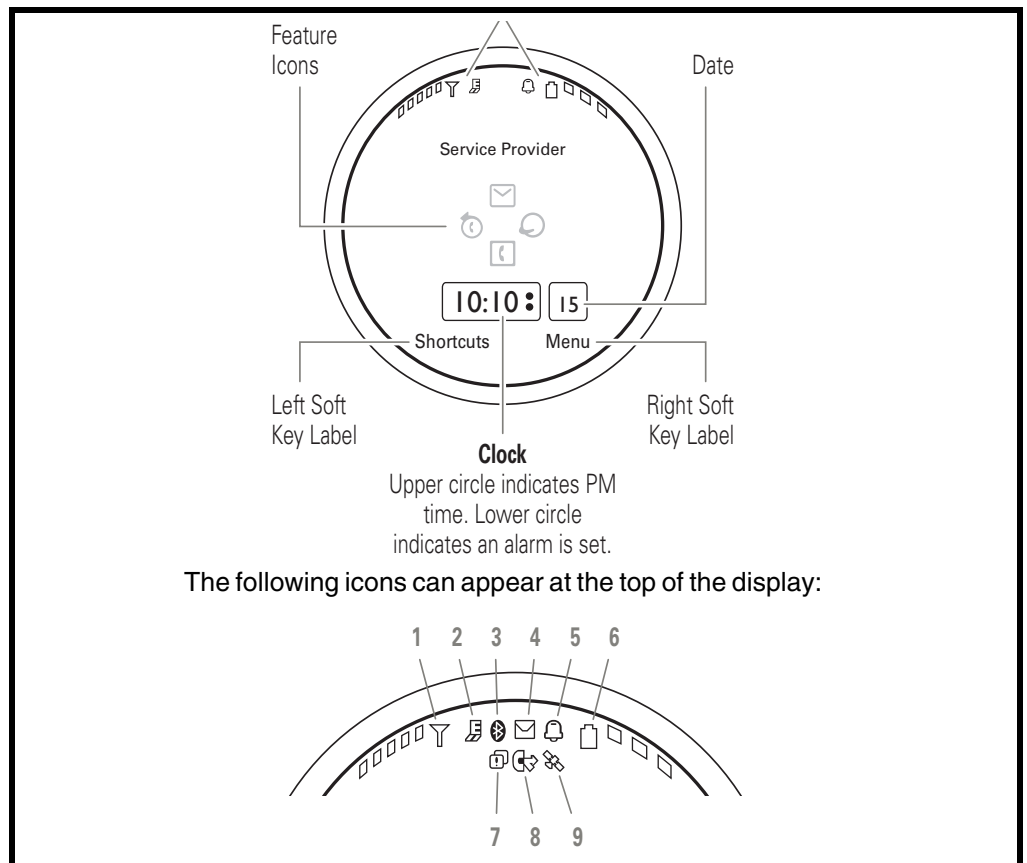

**Figure 3. Display and Status Indicators**



*Whether a phone displays all indicators depends on the programming and services to which the user subscribes.*



**Signal Strength Indicator** – Vertical bars (one to five) show the strength of the wireless network connection.

**EDGE/GPRS Indicator – Network/subscription-dependent feature:** Shows when your phone is using a high-speed *Enhanced Data for GSM Evolution* (EDGE) network connection , or *General Packet Radio Service* (GPRS) network connection .





**Bluetooth® Indicator** – Shows Bluetooth status:

- blue** = power on
- green** = connected
- flashing blue** = discoverable

**Message Indicator – Network/subscription-dependent feature:** Shows when you receive a new text message. Other indicators can include:



 = voicemail message       = email message





**Alert Style Indicator –** Shows the alert style setting:

 = ring only       = ring and vibrate  
 = vibrate only       = vibrate then ring  
 = silent

**Battery Level Indicator –** Vertical bars (one to three) show the battery charge level. Recharge the battery when your phone shows Low Battery.

**Missed Event Indicator – Network/subscription-dependent feature:** Shows when you have missed calls or unread messages.

**Active Line Indicator – Network/subscription-dependent feature:** Shows  to indicate an active call, or  to indicate when call forwarding is on. Indicators for dual-line-enabled SIM cards can include:

 = line 1 active       = line 2 active  
 = line 1 call forward on       = line 2 call forward on

The alarm indicator  appears in this location when an alarm is set.

**Location Indicator – Network/subscription-dependent feature:** Shows  when your phone is providing location information to the network, or  when location information is turned off.

## Battery Function

### Battery Removal

Removing the battery causes the device to immediately shut down and any pending work (for example, partially entered phone book entries or outgoing messages) is lost.



*To ensure proper memory retention, turn OFF the phone before removing the battery.*



*If the battery is removed while receiving a message, the message will be lost.*

## Operation

For detailed operating instructions, refer to the appropriate User's Guide.



## Tools and Test Equipment

The following table lists tools and test equipment recommended for disassembly and reassembly of Aura phones. Use either the listed items or equivalents.

**Table 2. General Test Equipment and Tools**

Motorola Part Number <sup>1</sup>	Description	Application
RSX4043-A	Torque Driver	Used to remove and replace screws
—	Torque Driver Bit T-6P, T-5P, T-4P, T-3 Apex 440-6IP Torx Plus or equivalent	Used with torque driver
	Small flat tip screw driver	
	Hinge timing lock and screw	
	Micro-coax protective cap	
	Micro-coax connector unmating tool	
0180386A82	Antistatic Mat Kit (includes 66-80387A95 antistatic mat, 66-80334B36 ground cord, and 42-80385A59 wrist band)	Provides protection from damage to device caused by electrostatic discharge (ESD)
6680388B67	Disassembly tool, plastic with flat and pointed ends (manual opening tool)	Used during assembly/disassembly of device
6680388B01	Tweezers, plastic	Used during assembly/disassembly
—	Digital Multimeter, HP34401A <sup>2</sup>	Used to measure battery voltage
8102430Z04	GSM / DCS Test SIM	Used to enable manual test mode
19501980	Generic Press	
W.FL-LP-IN Co-Axial Cable Tool	Co-Axial Cable Tool	Used to connect and disconnect the coaxial cable

1. To order in North America, contact Motorola Aftermarket and Accessories Division (AAD) at (800) 422-4210 or FAX (800) 622-6210; Internationally, AAD can be reached by calling (847) 538-8023 or faxing (847) 576-3023.

2. Not available from Motorola. To order, contact Hewlett Packard at (800) 452-4844.

## Disassembly/Reassembly

The procedures in this section provide instructions for the disassembly and reassembly of Aura phones. Tools and equipment used for the phone are listed in Table 2, preceding.



*Many of the integrated devices used in this equipment are vulnerable to damage from electrostatic discharge (ESD). Ensure adequate static protection is in place when handling, shipping, and servicing the internal components of this equipment.*

### Removing and Replacing the Battery Cover and Battery



*All batteries can cause property damage and/or bodily injury, such as burns if a conductive material, such as jewelry, keys, or beaded chains touch exposed terminals. The conductive material may complete an electrical circuit (short circuit) and become quite hot. Exercise care in handling any charged battery, particularly when placing it inside a pocket, purse, or other container with metal objects.*

1. Ensure the phone is turned off.
2. Press the battery latches on each side of the battery cover.



v561154

**Figure 4. Removing the Battery Cover**

3. Lift up and remove the battery cover. See Figure 4,

4. Lift up the battery at the side of the phone, then remove the battery from the phone. See Figure 5.



v561155

**Figure 5. Removing the Battery**



*There is a danger of explosion if the Lithium Ion battery is replaced incorrectly. Replace only with the same type of battery or equivalent as recommended by the battery manufacturer. Dispose of used batteries according to the manufacturer's instructions.*

5. To replace, align the battery with the battery compartment so the contacts on the battery match the battery contacts in the phone.
6. Insert the battery, contacts side first, into the battery compartment and then lower the opposite edge of the battery into position.
7. Align the battery cover to the rear housing, then lower the battery cover onto the phone and slide it into position.

## Removing and Replacing the Subscriber Identity Module (SIM)

1. Remove the battery cover and battery as described in the procedures.

2. Slide the SIM card out of the SIM holder, as shown in Figure 6.



v561156

**Figure 6. Removing the SIM**

3. Carefully lift the SIM from the phone.
4. To replace, insert the SIM into the holder, ensuring the notched corner of the SIM is inserted last.
5. Replace the battery and battery cover as described in the procedures.

---

## Transceiver Disassembly

1. Remove the battery cover, battery, and SIM as described in the procedures.
2. Insert the disassembly tool under the escutcheon and lift it up remove from the front housing. Avoid scratching the front housing surface.



v510562

**Figure 7. Removing the Escutcheon**

3. Discard the blade riding surface after removal.

4. Remove two screws from the transceiver front housing with the T4 driver.



v561220

**Figure 8. Removing the Transceiver Housing Screws**

5. Close the blade and turn the phone over. Use the driver and a T6IP bit to remove the 4 top cap screws.



v561222

**Figure 9. Removing the 4 Top Cap Screws**

6. Use the disassembly tool to press the battery door spring contact that protrudes from the opening in the top cap.

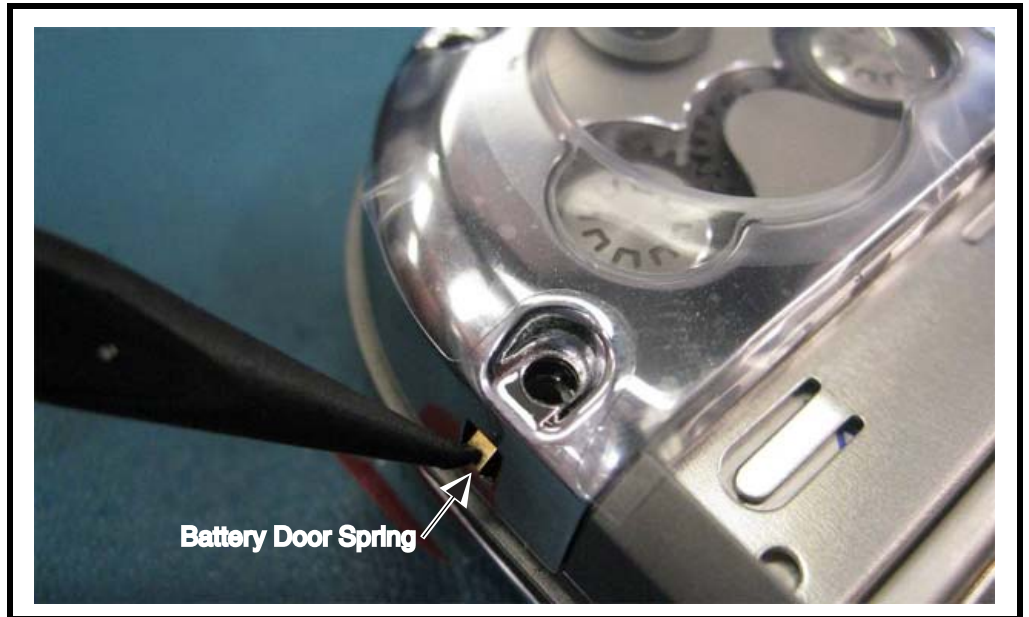

v561223

Figure 10. Pressing the 4 Battery Door Spring

7. Lift the top cap assembly to clear the battery door spring contact.

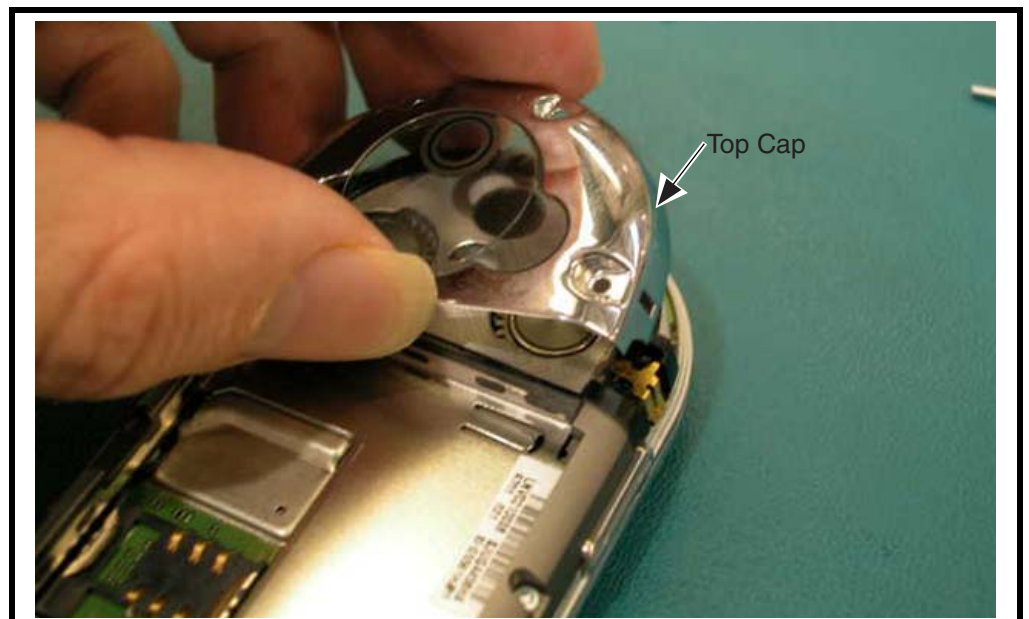

v561244

Figure 11. Removing the Top Cap

8. Slide a flat tool such as a pair of tweezers under the hinge bezel and gently lift the bezel off the hinge module.

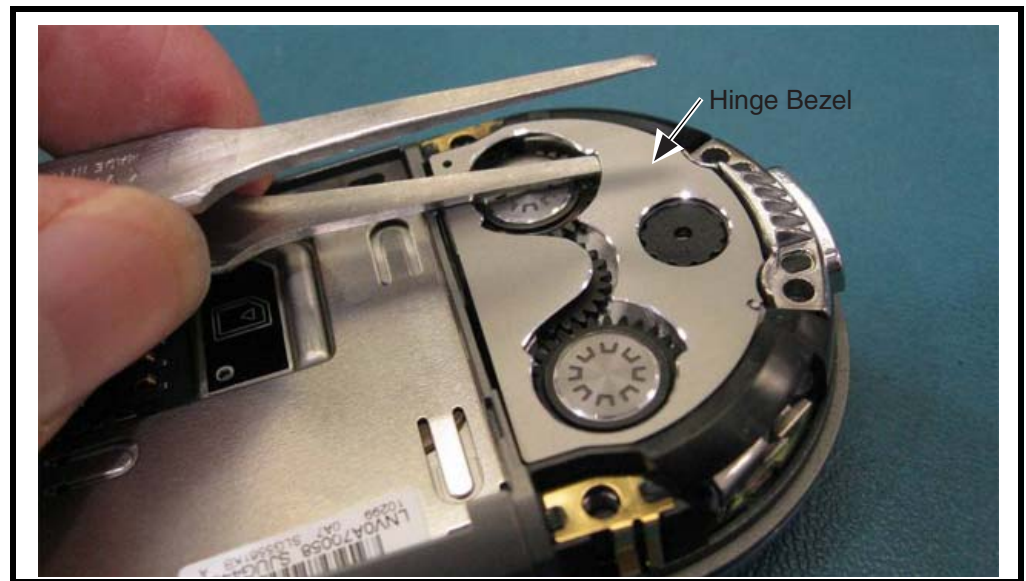

v561245

**Figure 12. Removing the Hinge Bezel**

9. Discard the hinge bezel after removal.
10. Align the hinge module timing lock with the hinge gear. Ensure the timing marks on the gears are centered in the notch in the timing lock (see Figure 12)



*It may be necessary to slightly open the blade either clockwise or counter clockwise to have the timing lock fall into place in the hinge module. Be careful not to let the hinge snap out of the closed position.*

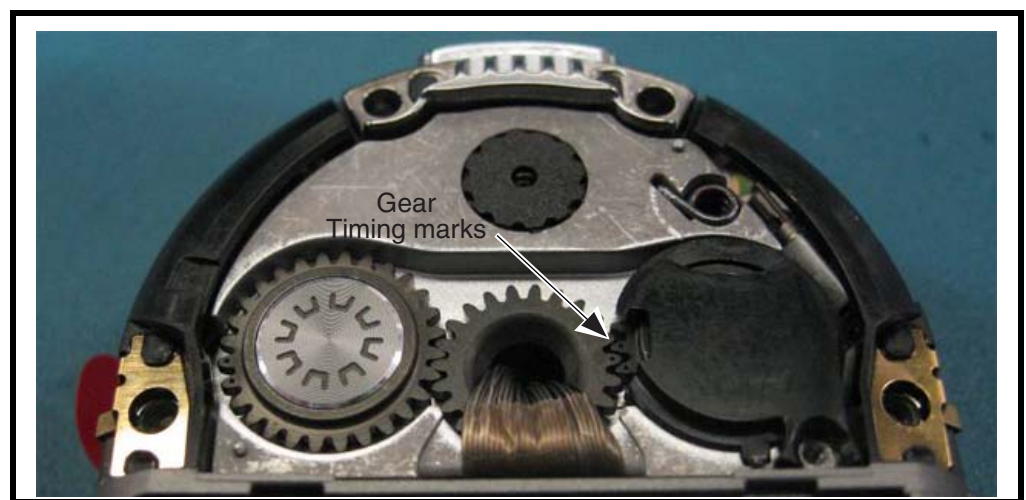

v561287

**Figure 13. Aligning the Hinge Gears**



11. The marked gears are visible as shown below.

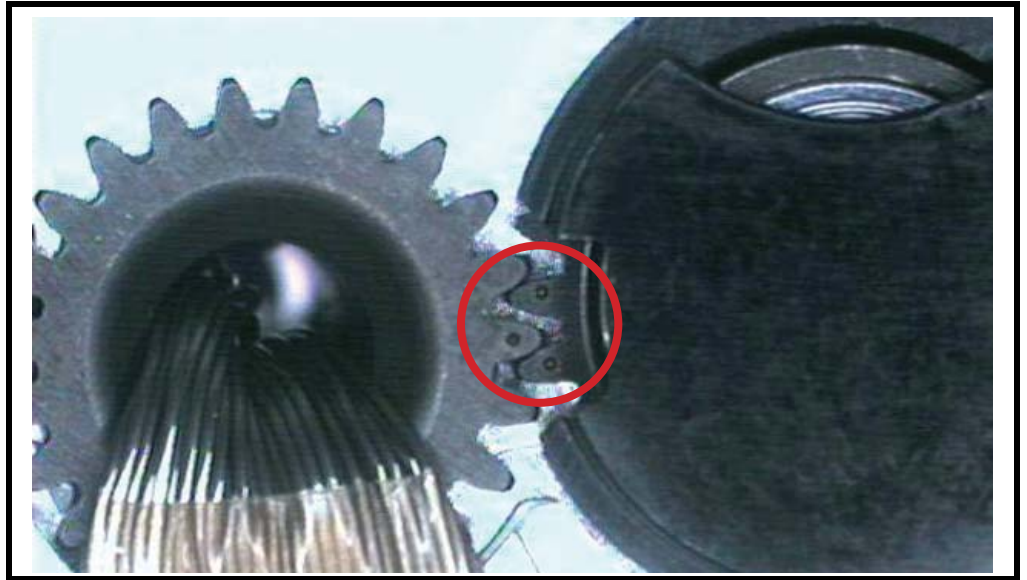

v561265

**Figure 14. Hinge Gear Timing Marks**

12. Secure the timing lock with the T3 Screw (tighten the T3 screw).



v561316

**Figure 15. Securing the Timing Lock**

13. Use the T4 driver to remove 4 screws from the rear housing.

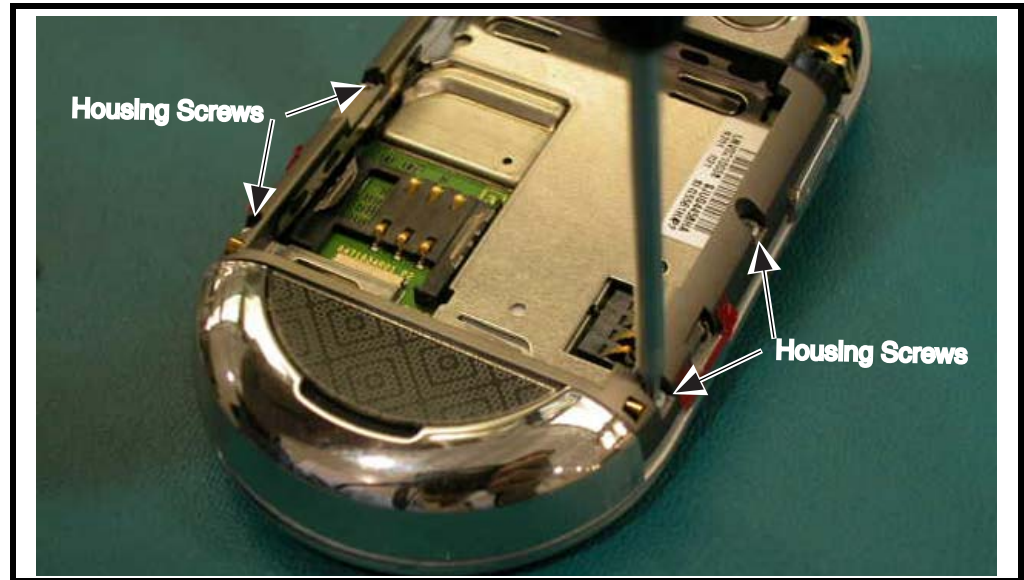

v561317

**Figure 16. Removing the T4 Housing Screws**

14. Lift the rear housing away from the assembly.
15. Remove the volume key if the adhesive on the side key flex pad is loose. (What do you do if the adhesive is not loose?)

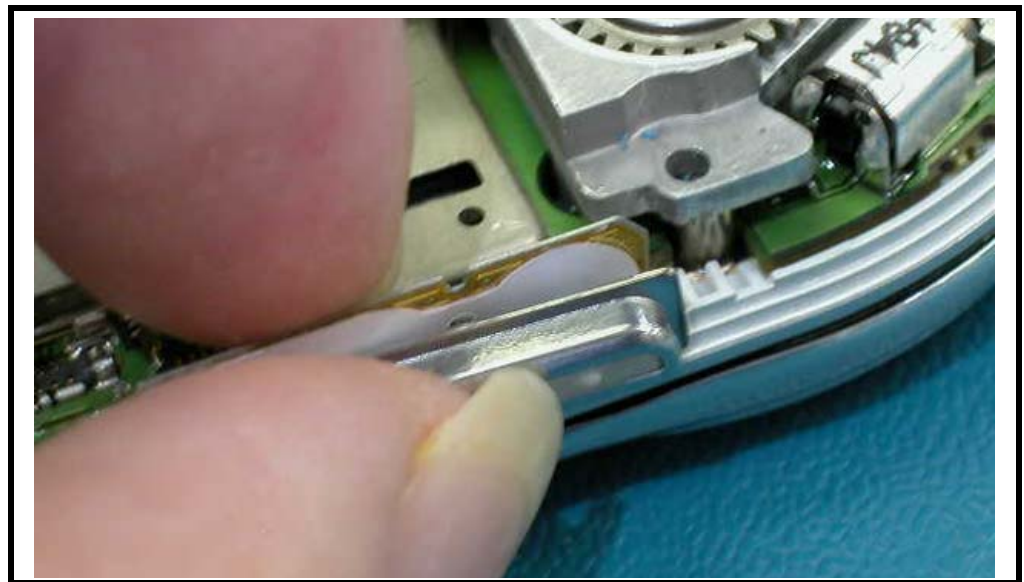

v561318

**Figure 17. Removing the Volume Key**

16. Use a pair of tweezers or other flat tool, lift and remove the detent torsion spring.

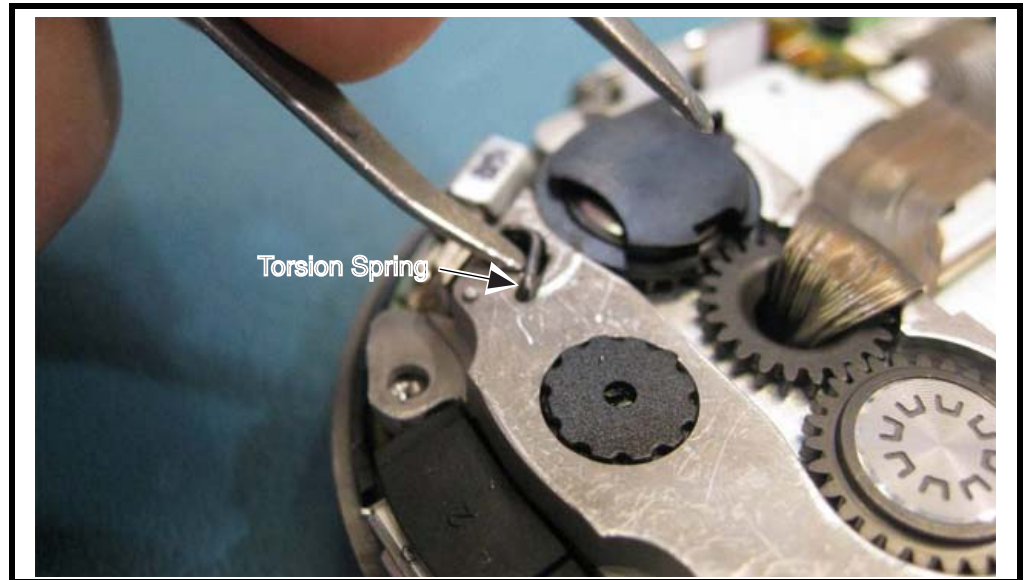

v561319

**Figure 18. Removing the Detent Torsion Spring**

17. Use the coaxial connector removal tool to lift one edge of the coaxial connector away from the board.



*Never pull on the coax wires to separate the coaxial connector from its socket.*

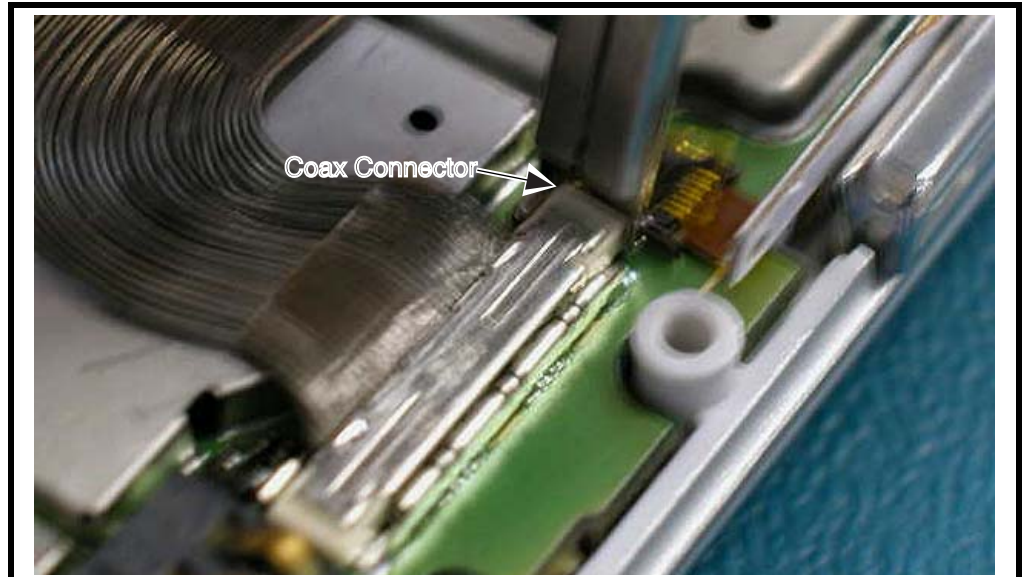

v561320

**Figure 19. Removing the Coaxial Connector**

18. Carefully curl the coax connector over on itself so the wires are close to the connector. Insert the protective cap such that the entire connector is within the cap (see Figures 20 and 21).

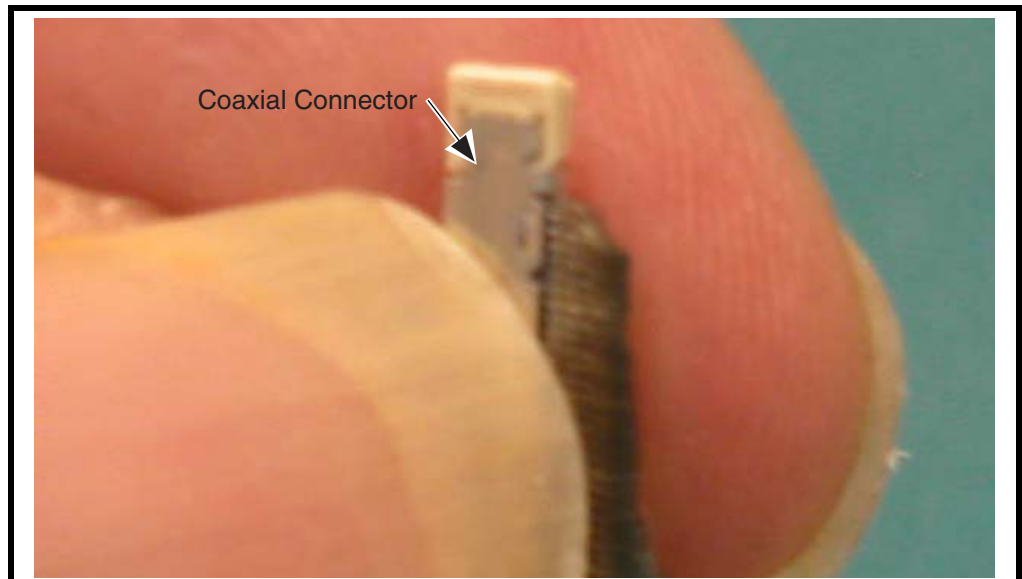

v561321

**Figure 20. Preparing the Coaxial Connector**



v561322

**Figure 21. Protecting the Coaxial Connector Protective Cap**

19. Push the protective cap into the center gear.

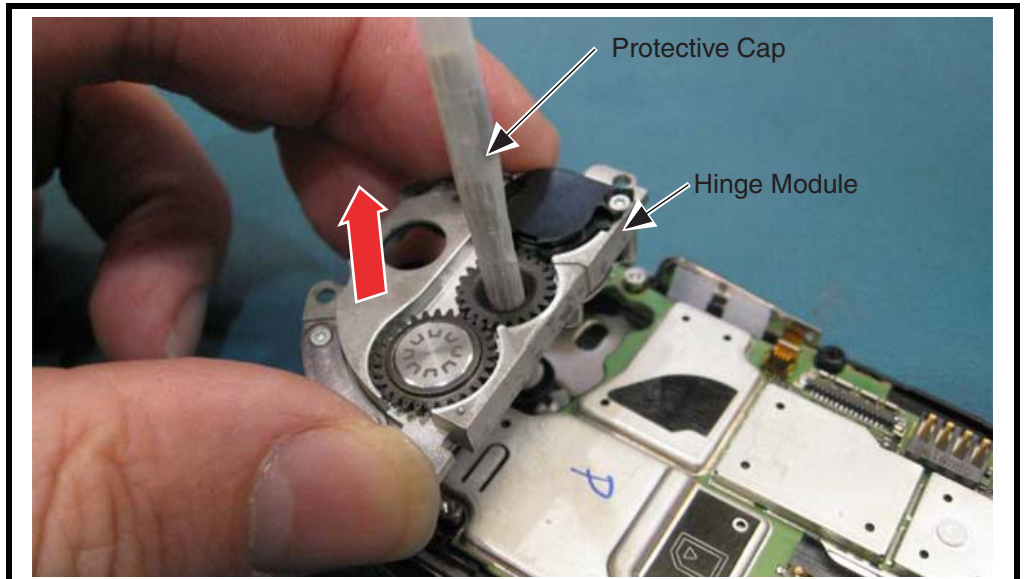

v561323

**Figure 22. Preparing the Coaxial Connector**

20. Lift the hinge module away from the transceiver assembly (see Figure 22).



*If necessary, push the imager barrel down to keep the imager from lifting off the hinge module.*

21. Lift the front housing and PCB away from the blade assembly.



*If necessary, rotate the PCB and front housing to allow the detent slider bearing to clear the bearing track.*

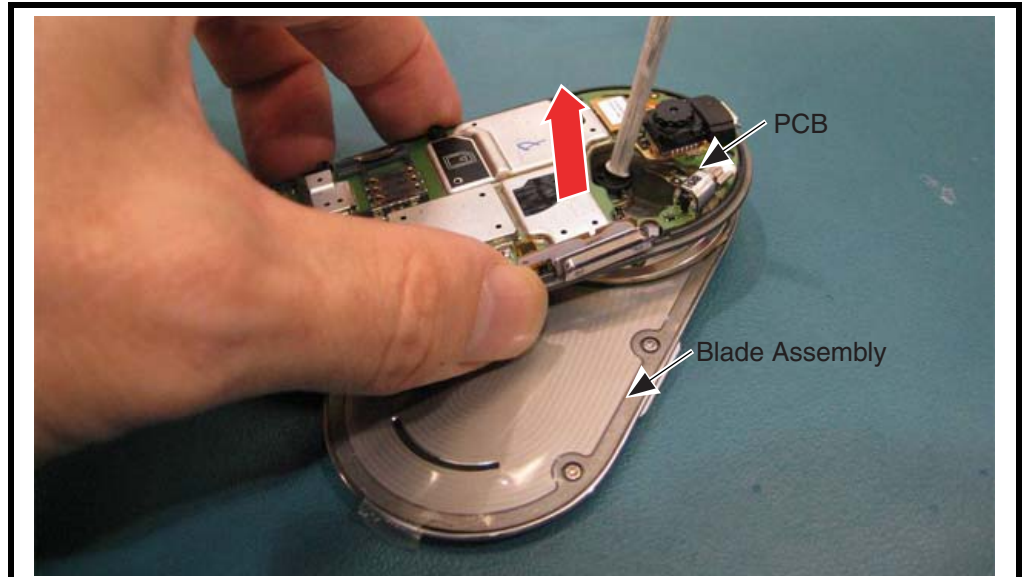

v561326

**Figure 23. Removing the PCB from the Blade Assembly**

## Blade Disassembly

1. Using the driver and a T5IP bit, remove the four screws from the blade assembly.

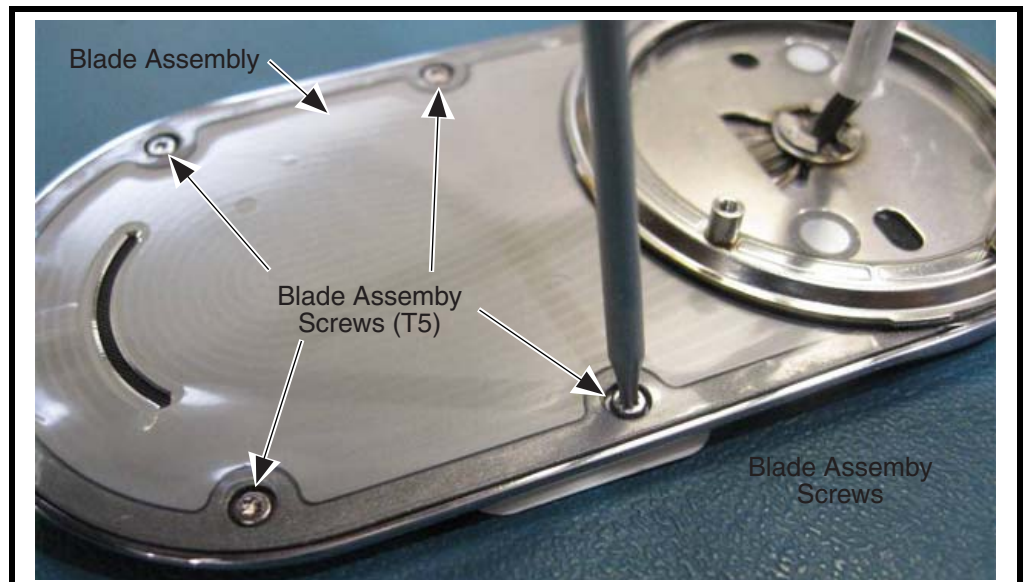

v561329

**Figure 24. Removing the Blade Assembly Screws**

2. Lift up on the blade plate and push the plate in the direction indicated to separate the blade front housing.

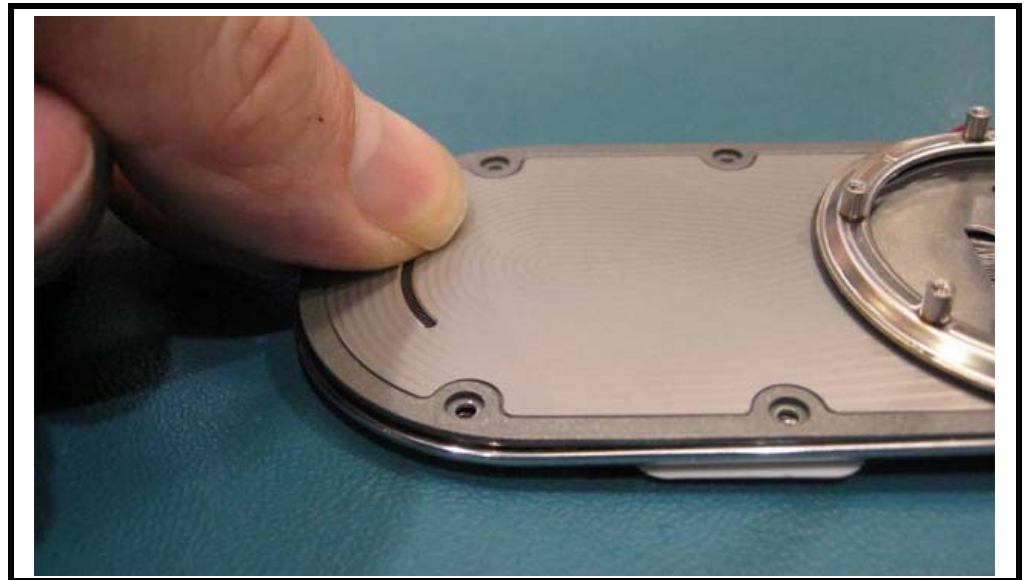

v561332

**Figure 25. Removing the Blade Plate from the Blade Assembly**

- Carefully lift away the blade plate from the blade front housing.

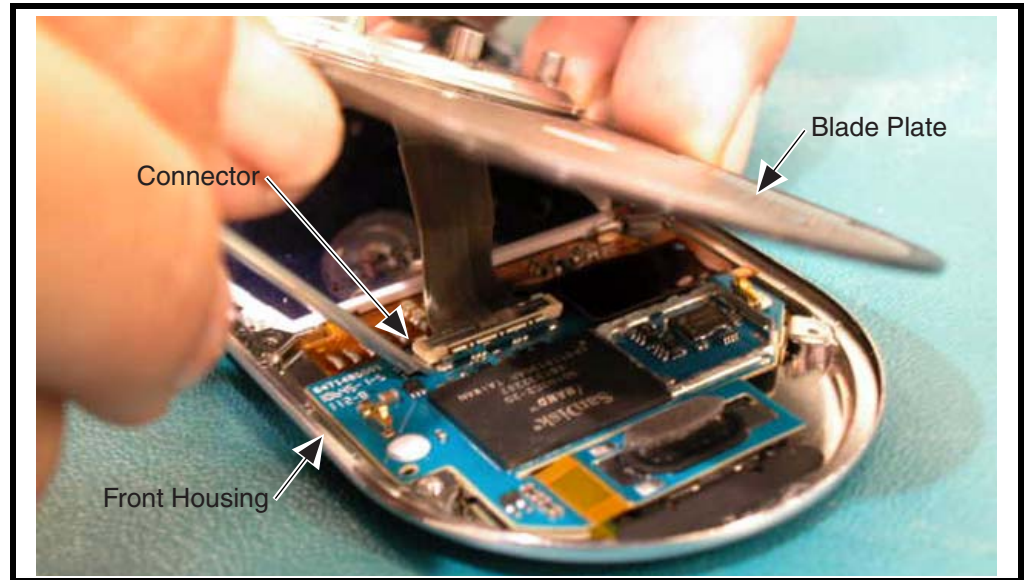

v561414

**Figure 26. Removing the Blade Plate from the Blade Assembly**



*The micro-coax prevents the blade plate and blade front housing from separating to far.*

- Separate the parts as far as possible and then use the coax connector tool to unmate the connector (see Figure 26).



5. Use the disassembly tool to lift the earpiece speaker away from the blade front housing. Ensure the speaker mesh is not pulled up by the adhesive.



*Do not lift on the flex portion of the speaker, lift only on the speaker*

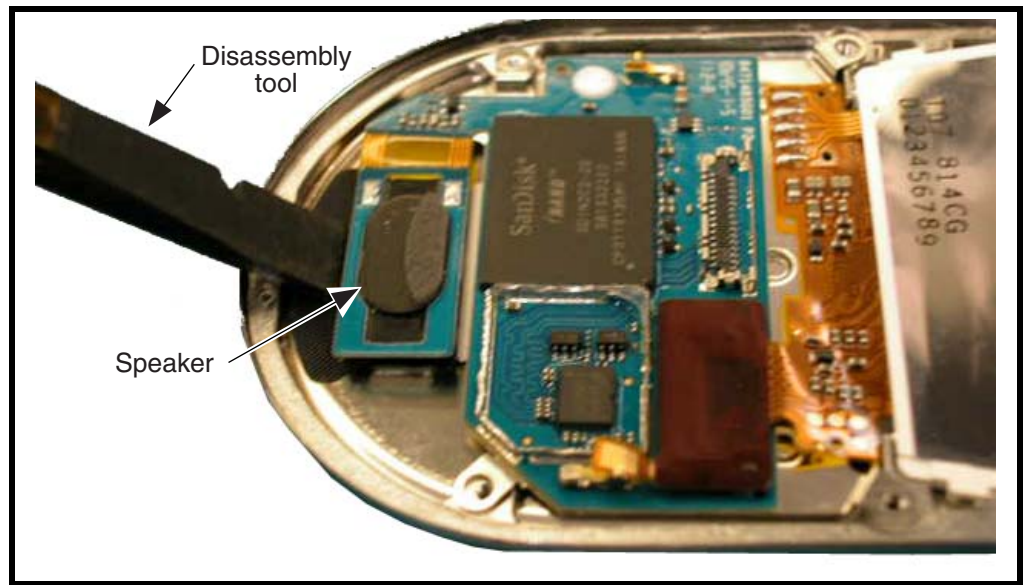

v561416

**Figure 27. Removing the Earpiece Speaker from the Blade Assembly**

6. Lift the blade PCB away from the front housing.

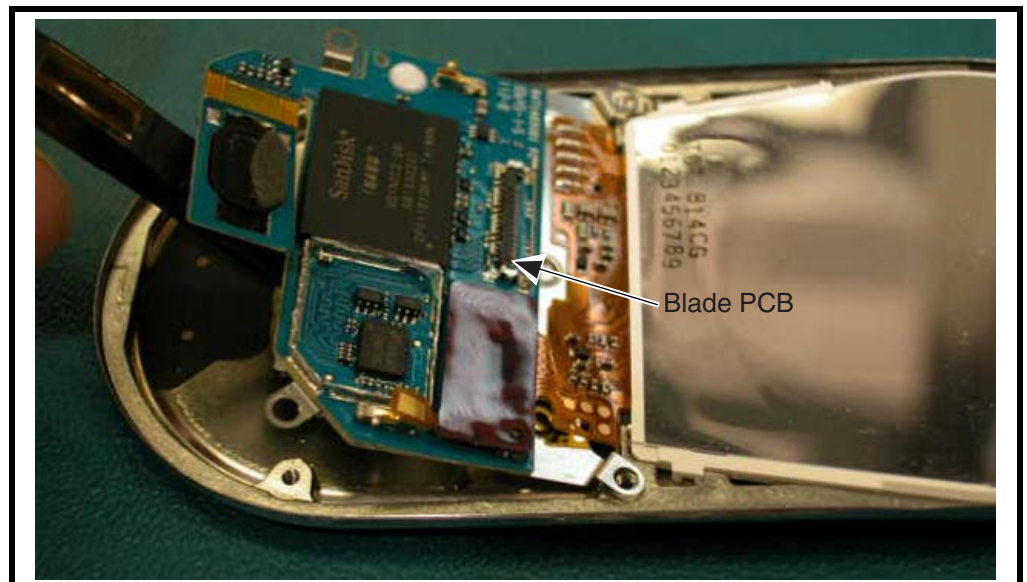

v561418

**Figure 28. Removing the Blade PCB from the Blade Assembly**

7. Use a pair of tweezers or similar tool to lift the display module out of the blade front frame (see Figure 29).



*Lift the display module from under the lip of the blade front housing.*

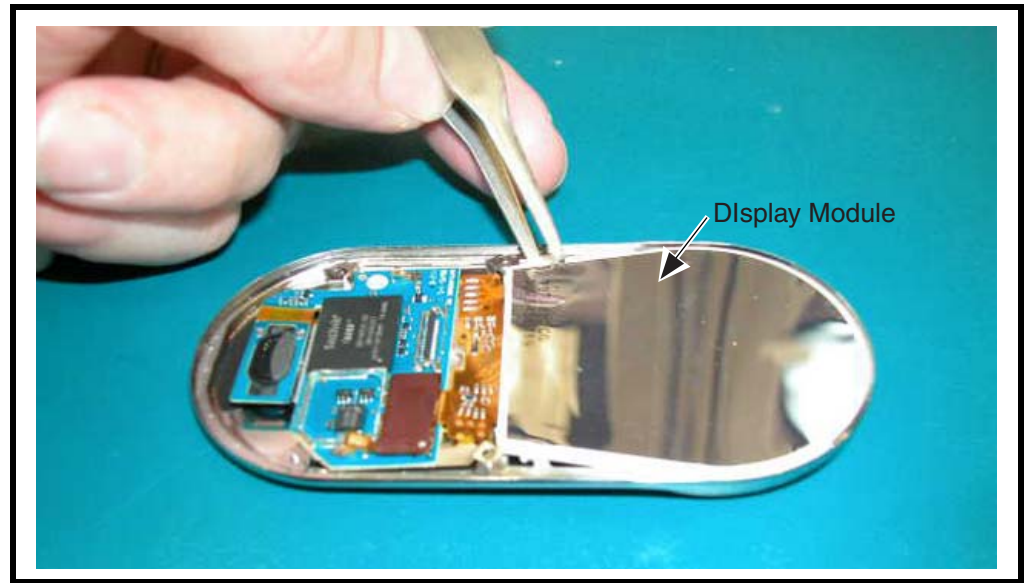

v561422

**Figure 29. Removing the Display Module from the Blade Assembly**

## Blade Disassembly Without Disassembly of the Transceiver

Use this procedure only when repair work is to be done on the display module, blade PCB, or blade front housing.

1. Open the blade.

2. Use the driver with the T5IP bit to remove the four screws from the blade assembly.

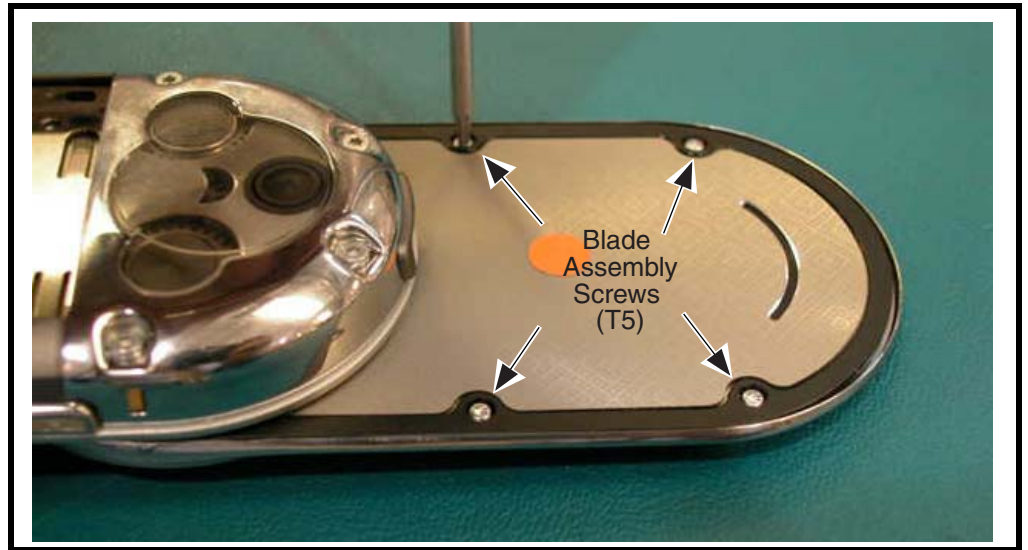

v561426

**Figure 30. Removing the Blade T5IP Screws from the Blade Assembly**

3. Continue the blade disassembly with step 4 on page 32.

---

## Assembling the Blade Assembly

### Assemble the Blade PCB to the Display Module

1. Align & mate the display module board to board connector to the connector on the blade board assembly. Press firmly to ensure the connectors are fully mated.



*Do not put pressure on the back of the display as this may damage the film within the display or the light guide.*

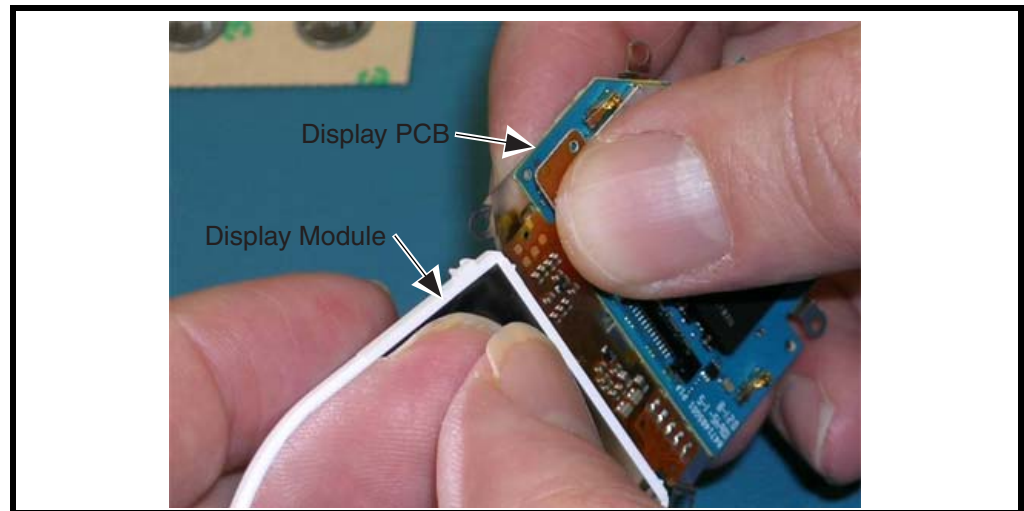

v561432

**Figure 31. Assembling the Blade PCB to the Display Module**

### Assemble the Blade Board/Display Module to the Blade Front Housing

1. Remove the liner from the inside of the lens. Check the lens for smudges, finger prints or other cosmetic defects. Use de-ionized air, to blow out the inside of the blade and front housing lens to remove any loose foreign material.

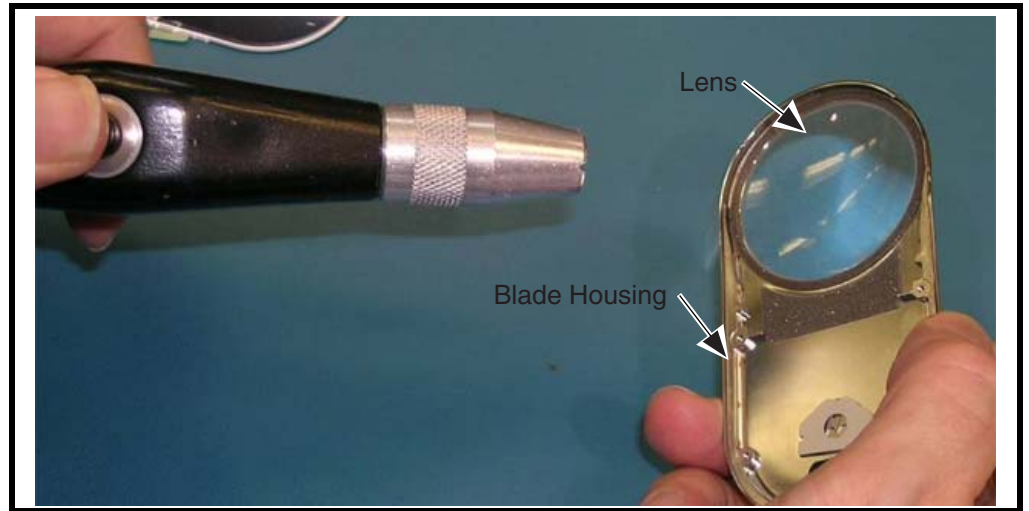

v561432

Figure 32. Assembling the Blade PCB to the Display Module

2. Remove the protective liner from the display module. Check for smudges, finger prints or other cosmetic defects.
3. Use de-ionized air to blow off the display module to remove loose foreign material.



v561586

Figure 33. Cleaning the Display Module

4. Place top of display module under the top lip on the blade front housing.

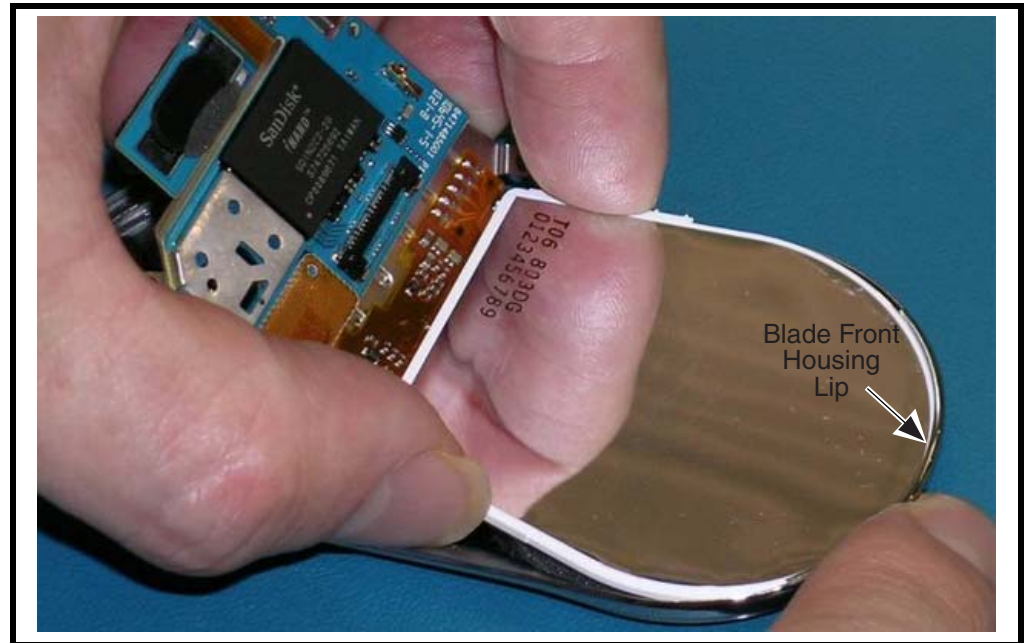

v561587

**Figure 34. Placing the Display Module Under the Housing Top Lip**

5. Ensure white tabs on display module frame are below the small protruding arms on the front housing frame. Press the display module down into the front housing such that the small ribs on the display module frame are pressed into the front housing frame.



*Press only on the white frame. Do not apply any pressure to the back of the display.*

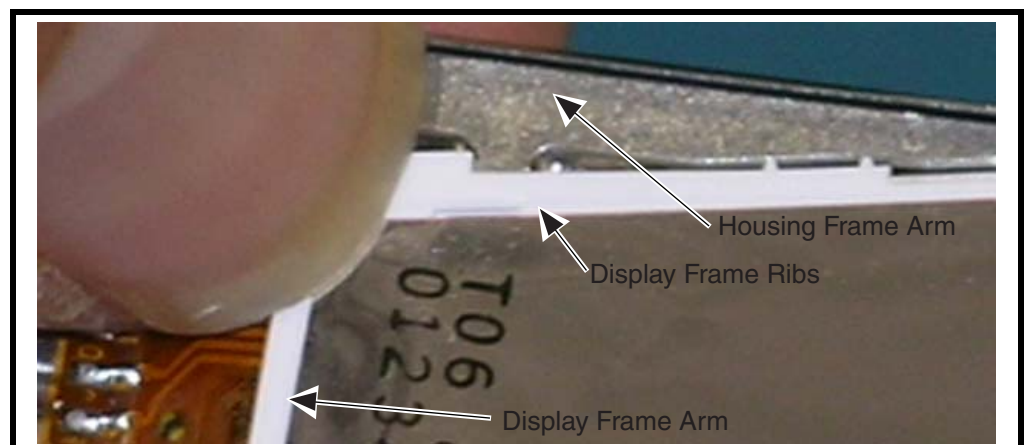

v561587

**Figure 35. Placing the Display Module Under the Housing Top Lip**

6. Verify the boss holes on the blade board support are aligned to the holes in the front housing frame.
7. Carefully pull up on the speaker section of the blade board. Peel off the adhesive liner on the speaker.

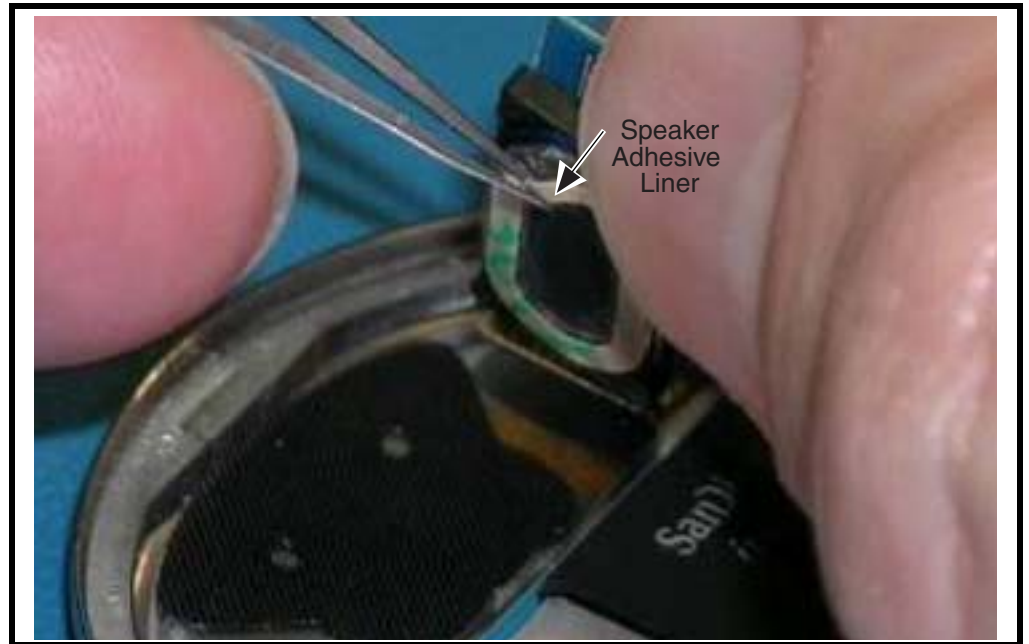

v561589

**Figure 36. Removing the Adhesive Liner from the Speaker**

8. Allow the speaker section of the blade board to return to normal position & then press on the speaker to set the adhesive against the speaker mesh.

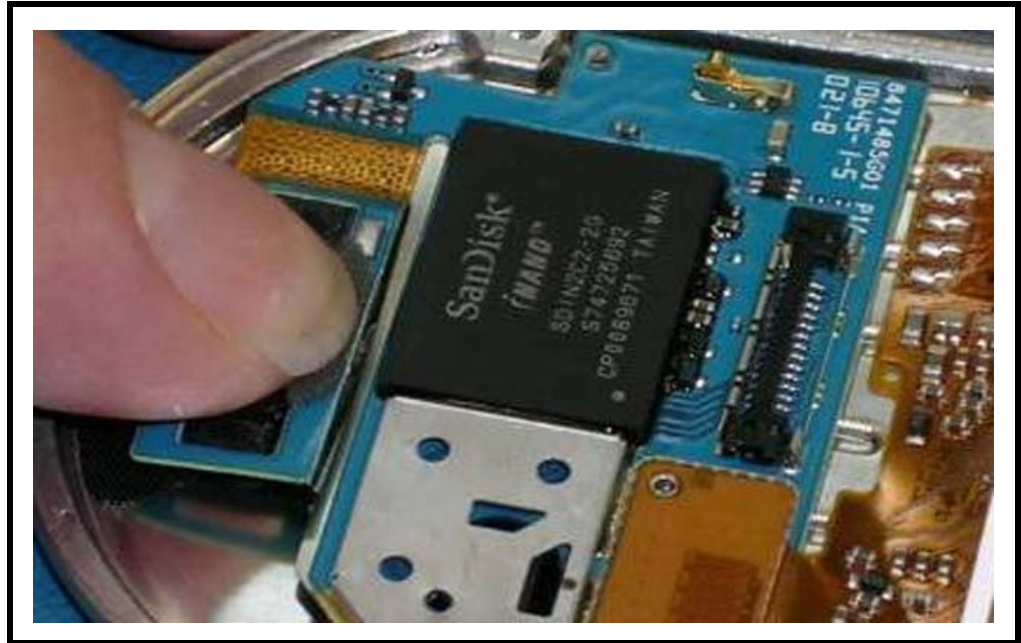

v561590

**Figure 37. Pressing the Speaker to set the Adhesive**

9. Place the blade front housing in the press fixture and press the speaker to activate the PSA.
10. Press the adhesive at 30 psi for 7 seconds.



### Assemble the Blade Plate Assembly

1. Use magnet placement fixture, 2908.
2. Place blade plate onto fixture with bearing facing down.

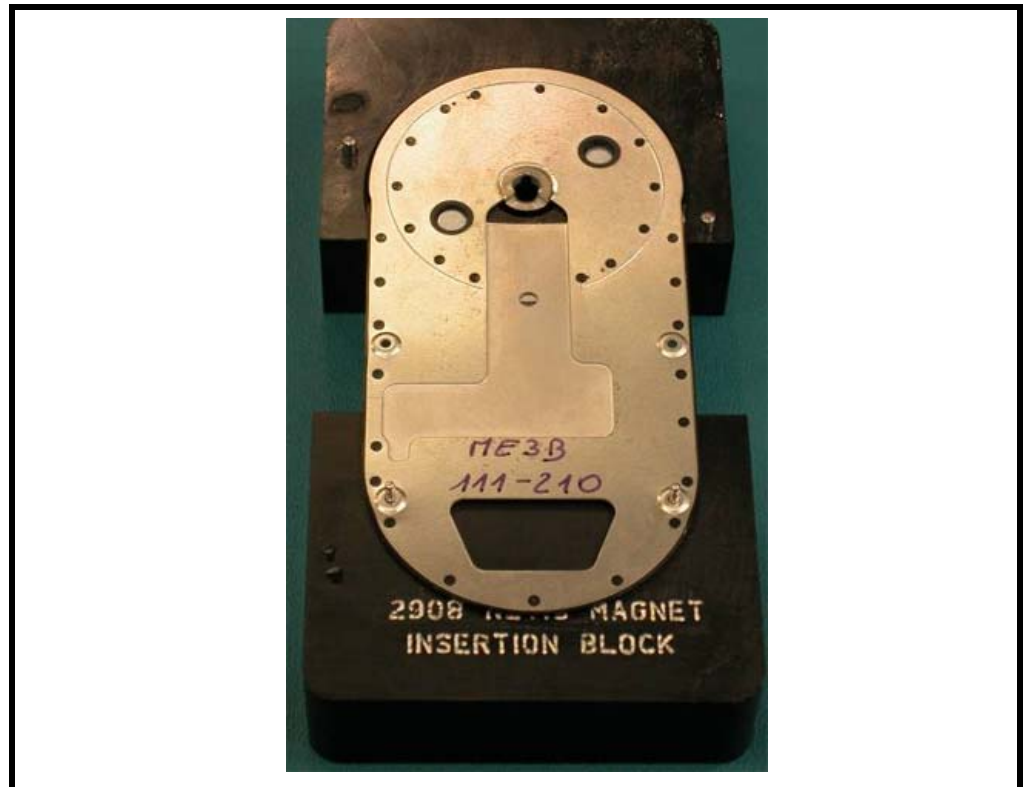

v561614

**Figure 38. Placing the Blade Plate into the Magnet Insertion Fixture**

3. Place magnet near bottom left magnet hole. Push magnet near black magnet insert. Magnet should be pulled into the insert by the magnet in the fixture.

---

This should automatically determine the correct orientation of the magnet. Repeat for the second magnet.

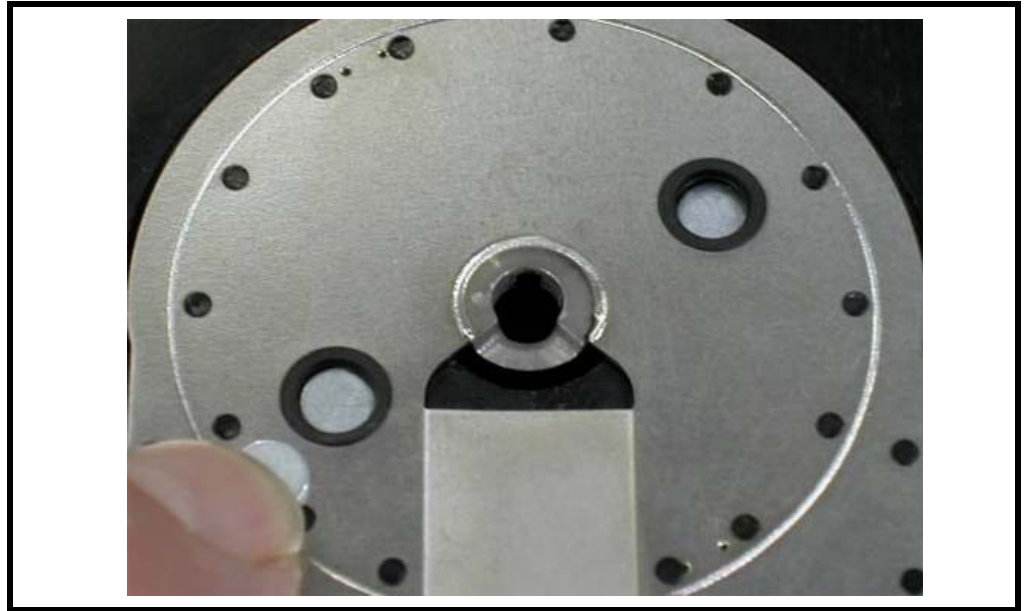

v561615

**Figure 39. Placing the Magnets**

4. Press down firmly on the magnets to press them into the insert. Ensure the magnets are even with the insert and plate.

5. Remove the mylar display spacer from the liner sheet. Place the mylar so that the holes in the top liner align to the posts in the fixture.

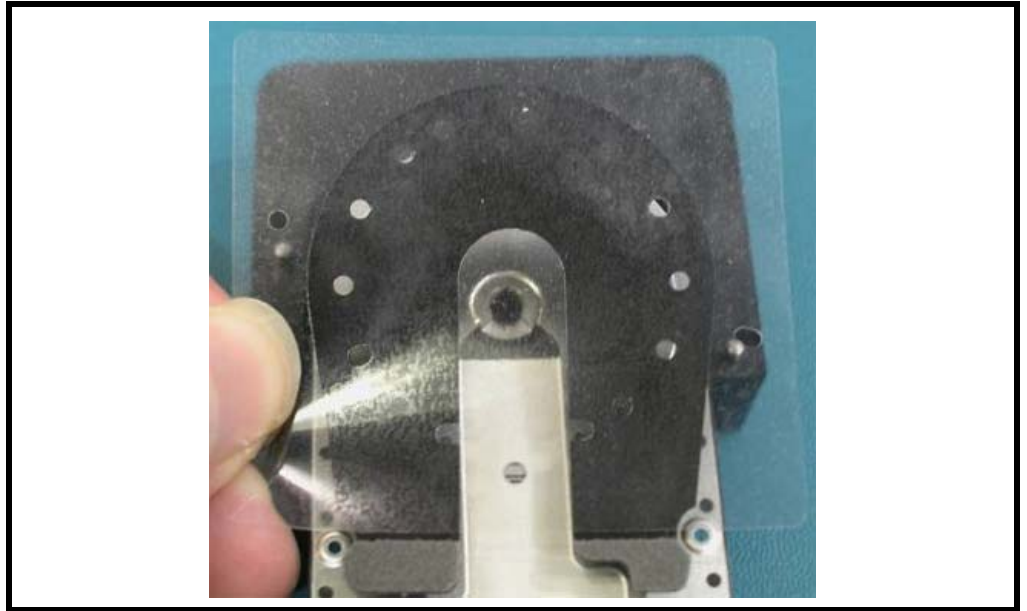

v561615

**Figure 40. Removing the Mylar Display Spacer**

6. Press down on the mylar to stick the adhesive to the plate. Ensure the mylar sits flat & there is clearance around the plastic posts. Check to ensure the magnets are not pushing up on the mylar.

7. Remove the display backer pad from the liner. Align the pad to the marking in the etched region on the left side of the plate, as indicated.



**Figure 41. Attaching the Display Backer Pad**

8. Stick the pad to the plate and press down to set the adhesive.

9. Remove blade insulator tape from the liner. Align the upper right edge of the tape to the boss hole. The left edge of the tape should align to the opening for the speaker mesh.

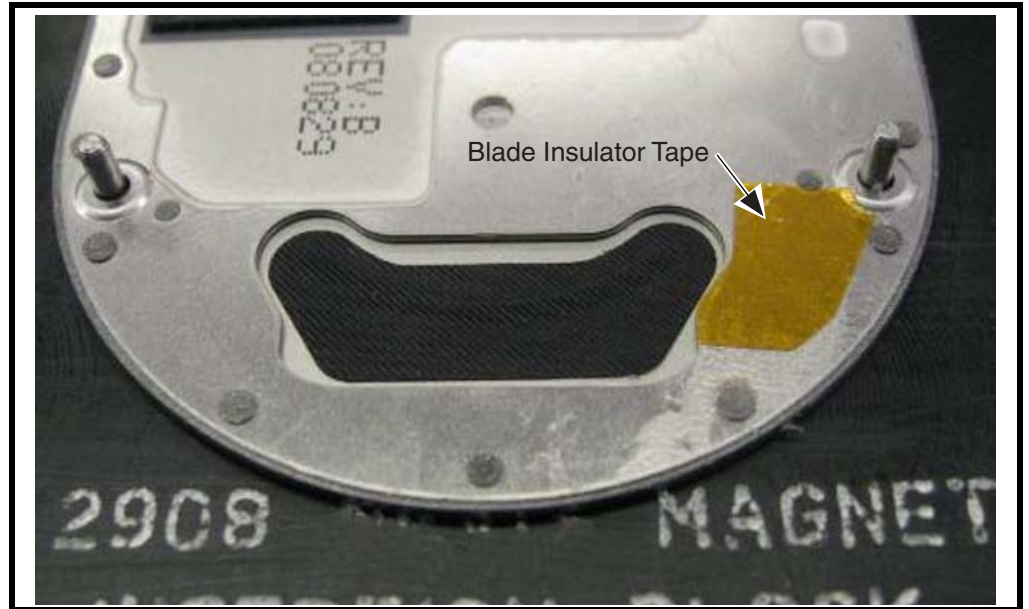

**Figure 42. Attaching the Blade Insulator Tape**

10. Stick the tape to the plate and press down to set the adhesive.
11. Remove the tertiary speaker mesh from the liner.

- Align the edge of the speaker mesh to the opening on the inside of the blade plate.

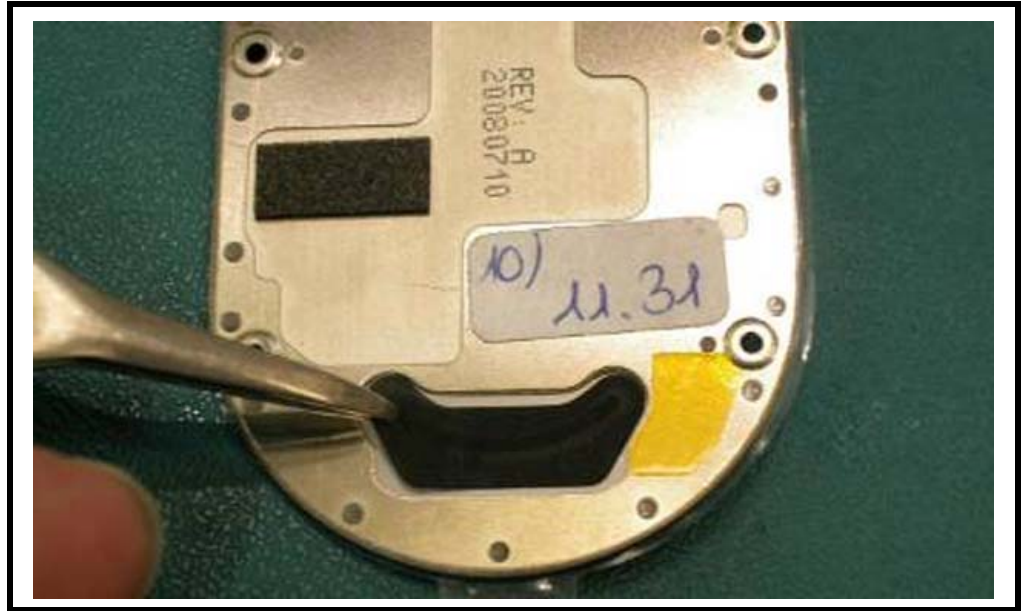

v562884

**Figure 43. Attaching the Speaker Mesh**

- Lay the remainder of the mesh against the inside of the rear bezel. Press down on the mesh to activate the PSA.

---

### Assemble the Micro-Coax to the Blade Plate Assembly

1. Curl the micro-coax connector (adjacent to the curved coax wires) over on itself & insert into the long protective cap. Fully insert the connector until the open end is at the loose wires.

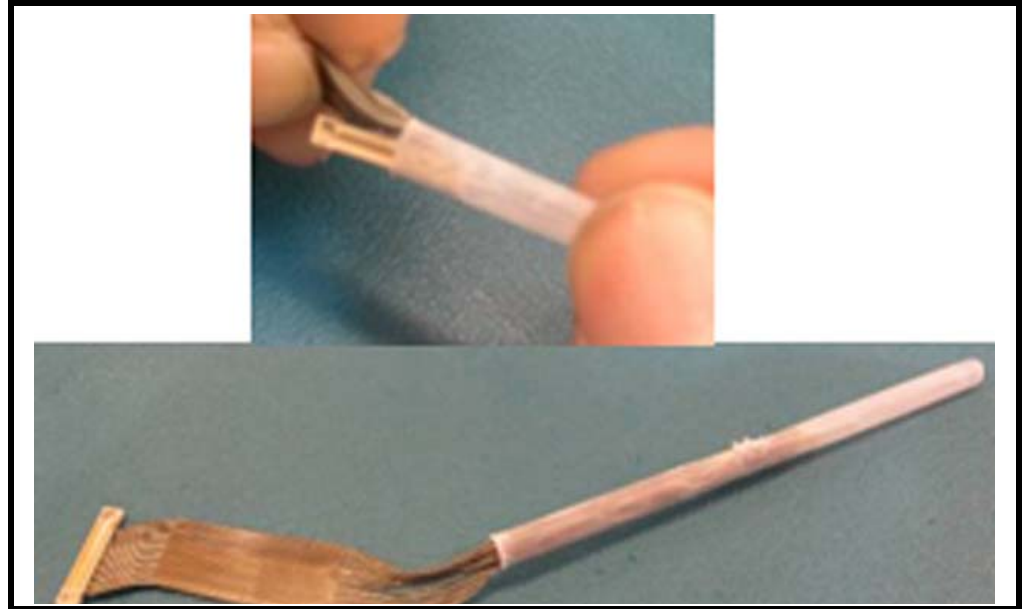

v562885

Figure 44. Curling the Micro-Coax

2. Feed the capped connector through the blade plate coupler from the side with the black mylar. Continue feeding the micro-coax through the coupler until the loose wires are in the middle of the coupler.

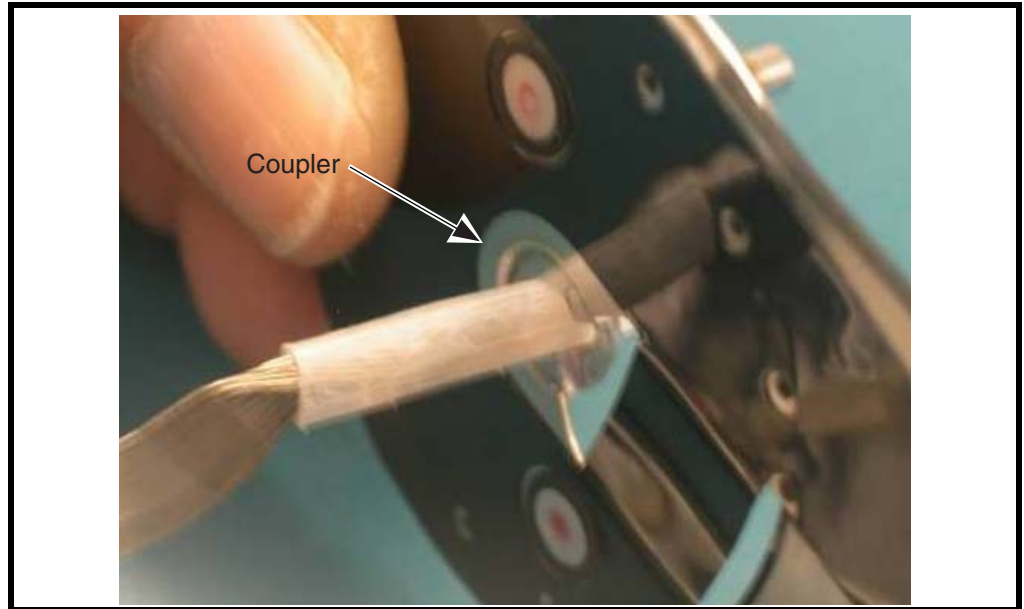

v562886

**Figure 45. Feeding the Micro-Coax Through the Coupler**

3. The plate is marked with location aids for the connector and the coax.

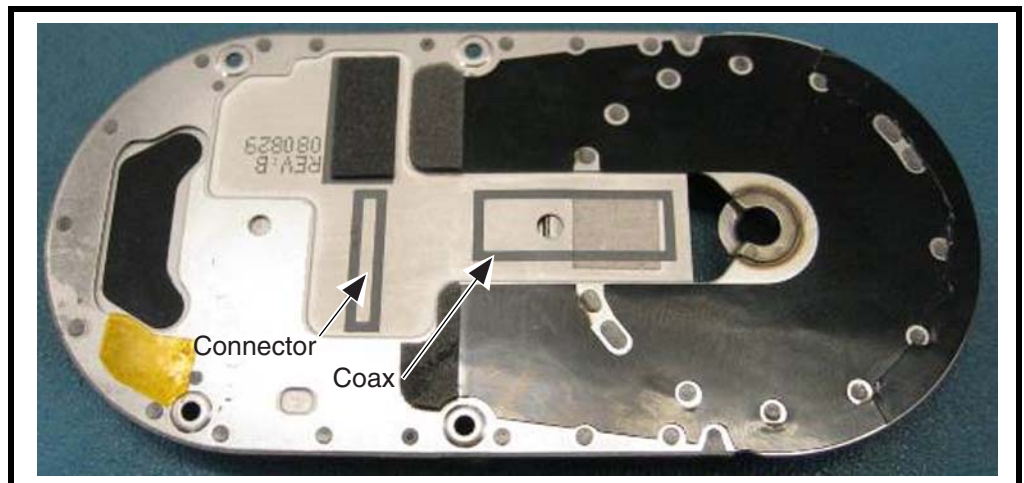

v562887

**Figure 46. Feeding the Micro-Coax Through the Coupler**



4. Align the coax connector so that it is in the marked area in the etched area.



Figure 47. Aligning the Coax Connector

5. Holding the connector in this location, remove the adhesive liner. Ensure the coax is aligned with the marking in the middle of the etched area. Press down on the coax to activate the PSA under the coax.

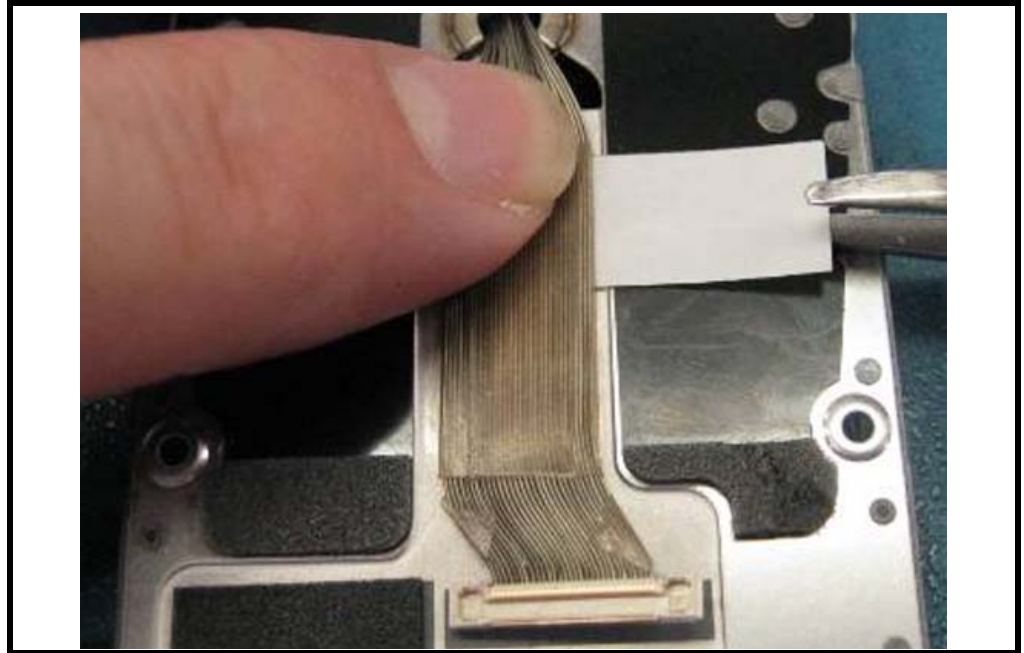

v562889

**Figure 48. Adhering the Coax**

6. Ensure the coax connector is positioned as shown. Ensure the loose wires are all routed through the trough in the coupler. No wires should be sitting on top of the coupler.

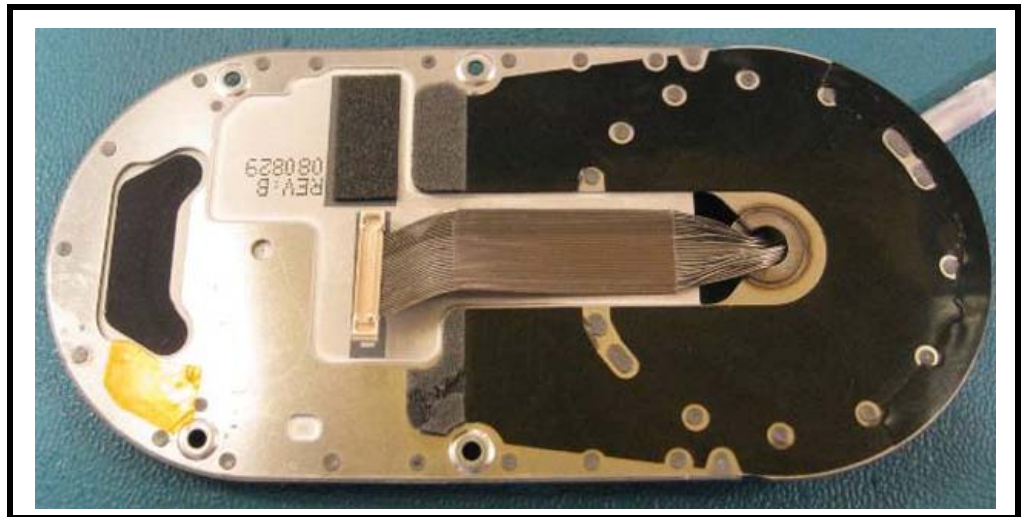

v562891

**Figure 49. Positioning the Coax Connector**

---

### Assemble the Blade Front Housing to the Blade Plate

1. If necessary, manually remove the black insert from the micro-coax connector on the blade board (may have been previously removed for testing). Pull the insert from the ends only. No tool should be used for this step because this may damage the connector.

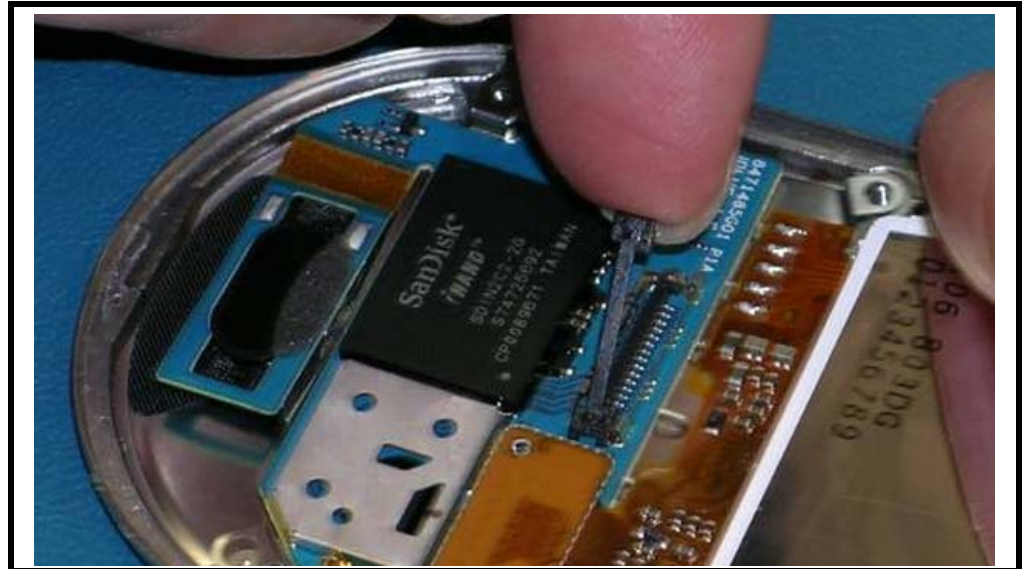

v562892

Figure 50. Removing the Coax Insert

2. Bring the blade plate into proximity to the blade board and display. Align the coax connector to the connector on the blade board. Press firmly and uniformly onto the connector to mate. There should be two distinct snaps when the left and right sides of the connector are mated.



v562893

**Figure 51. Inserting the Coax to the Connector**

3. Figure below shows a properly mated connector.

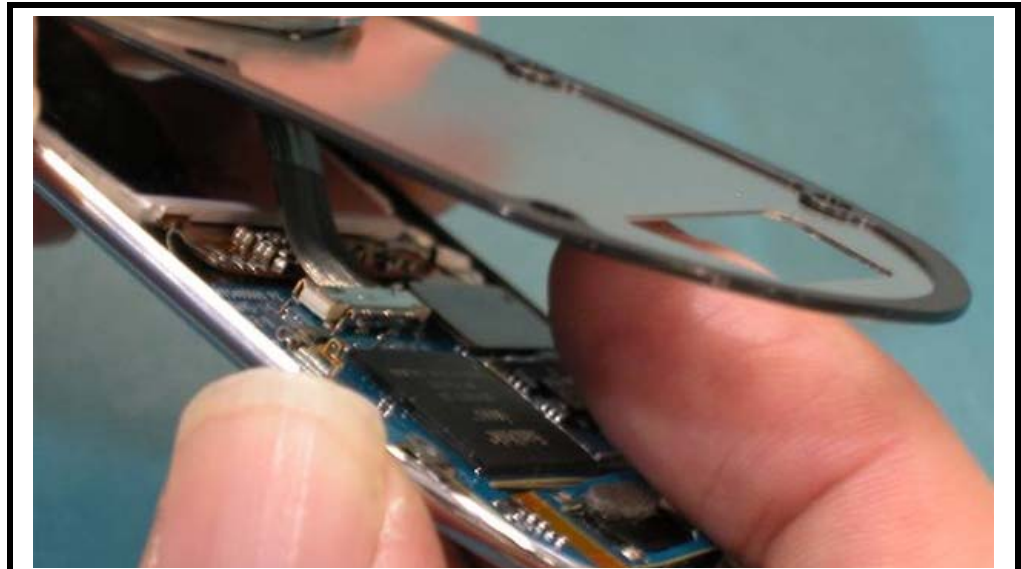

v562894

**Figure 52. Correct Coax Connection**

4. Align the blade plate assembly so that the top edge of the plate is just below the curled edge of the blade front housing.

- a. Press the blade plate downward (1) against the blade front housing. Press only on the bearing race and not in the center of the plate. This may exert pressure on the back of the display resulting in display defects.
- b. While maintaining the downward pressure on the blade plate, push the blade plate toward the top of the blade front housing (2). There may be an audible click when the blade plate moves under the lip on the blade front housing. At this point the blade plate assembly should be held securely by the blade front housing.



v562895

**Figure 53. Aligning the Blade Plate Assembly**

5. After the blade plate assembly is pushed into position, hold the nose of the blade plate down and push down (3) to close the gap between the blade plate and the blade plate front housing at the nose.

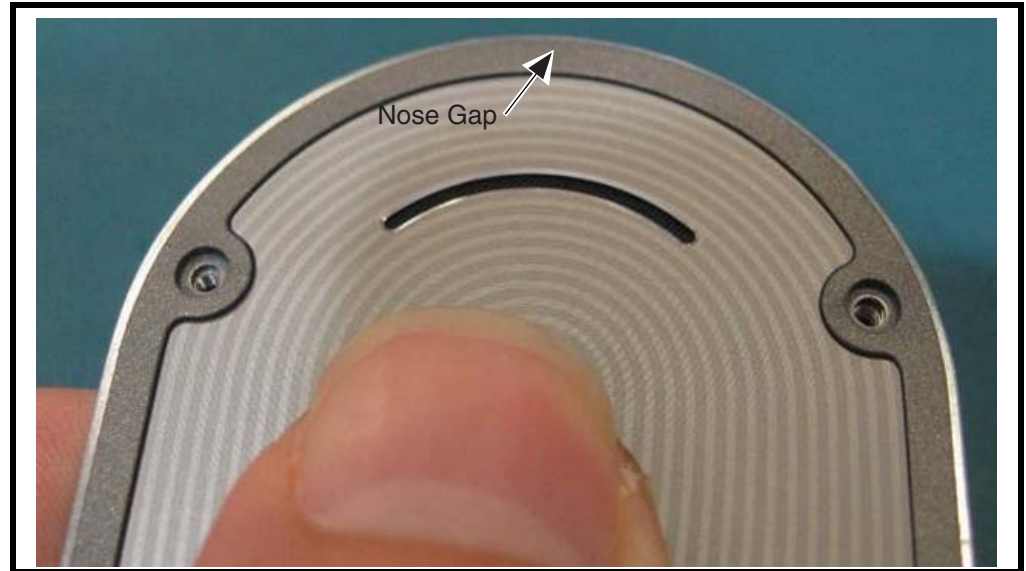

**Figure 54. Closing the Gap Between the Blade Plate and Front Housing**

6. Visually inspect the coax through the opening in the plate below the coupler. The coax wires should all be centered in the opening and routed through the coupler trough. If they are not then the blade plate must be removed and the coax re-routed.

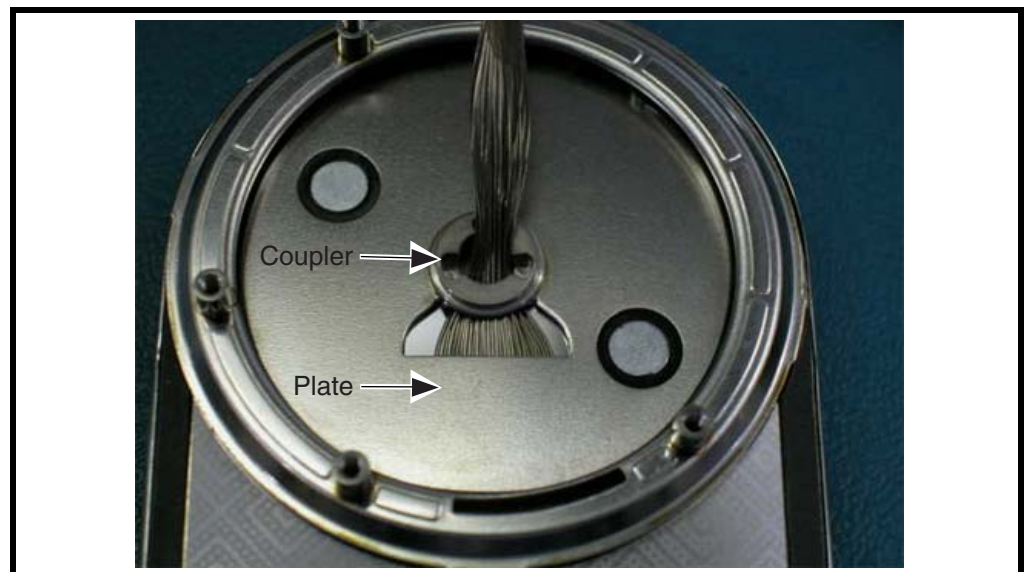

**Figure 55. Inspect the Coax Wires for Correct Routing through Coupler**

7. Make sure the blade plate assembly and the blade board support holes are aligned. Using a driver with a T5IP bit, tighten the screws in the order indicated. Take care not to scratch the cosmetic surfaces on the blade plate. Torque should be 1.5 in-lbs.

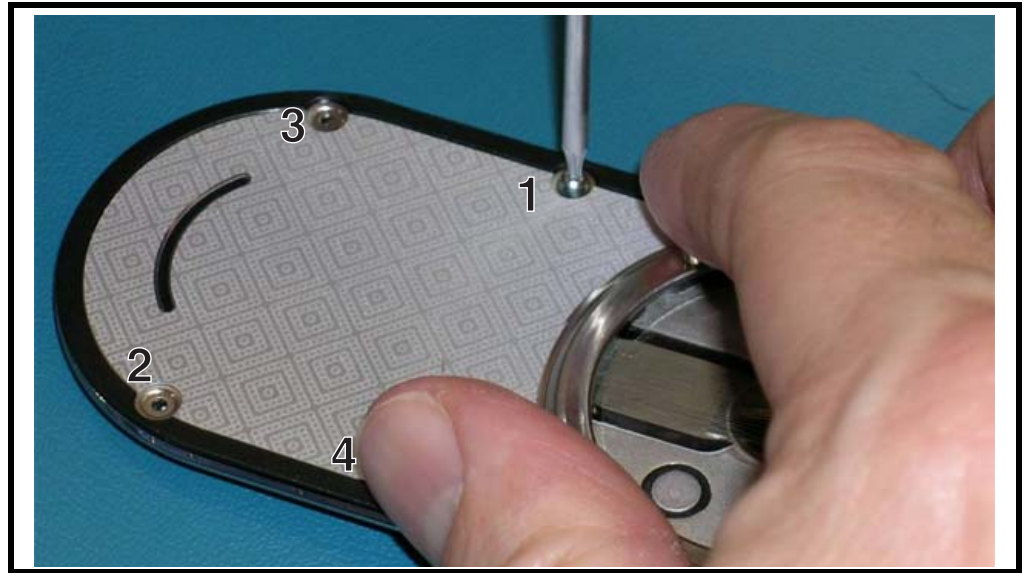

v562897

Figure 56. Inserting the Blade Assembly T5 Screws

### Front Housing Assembly – Assemble the Keypad to Front Housing

1. Align the top of the keypad such that metal keycaps are on the outside of the front housing and the silicone is on the inside of the front housing.

- Carefully bend the keypad so that the silicone bends between the rows of numeric keys.



v562898

**Figure 57. Bending the Keypad While Inserting it onto the Front Housing**

- Align the bottom portion of the keypad so the silicone goes inside the front housing and the keycaps remain on the outside of the front housing.



v562899

**Figure 58. Aligning the Keypad to the Front Housing**



4. Flip the front housing over. Use a black stick or similar device to pull the silicone side flaps into the inside of the front housing.

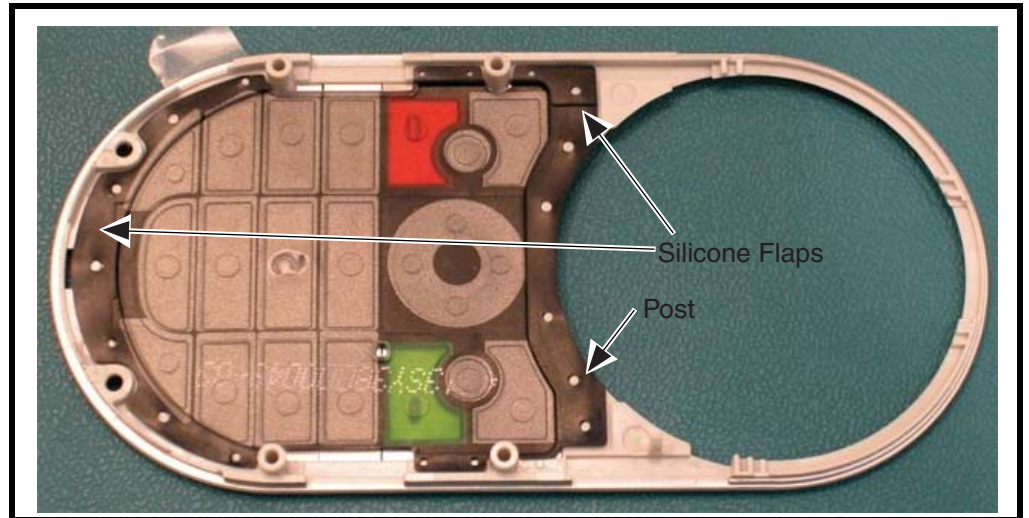

v562900

**Figure 59. Checking the Keypad Silicone Flaps**

5. Repeat on the other side of the keypad.
6. Use the black stick or tweezers to ensure all silicone flaps are pulled inside the housing. Pull the flaps tight so the holes fit over the posts in the front housing.
7. Visually inspect all posts are through the holes.
8. Check that the edges of the metal keycaps are on the outside of the housing.

---

## Transceiver Assembly

### PCB Assembly: Assemble Dome Array/Light Sheet & Light Blocking Mylar

1. Remove the dome array/light sheet from the adhesive liner.
2. Place dome array/light sheet onto alignment fixture. Ensure the sheet is aligned properly to the three spring loaded pins on the fixture.

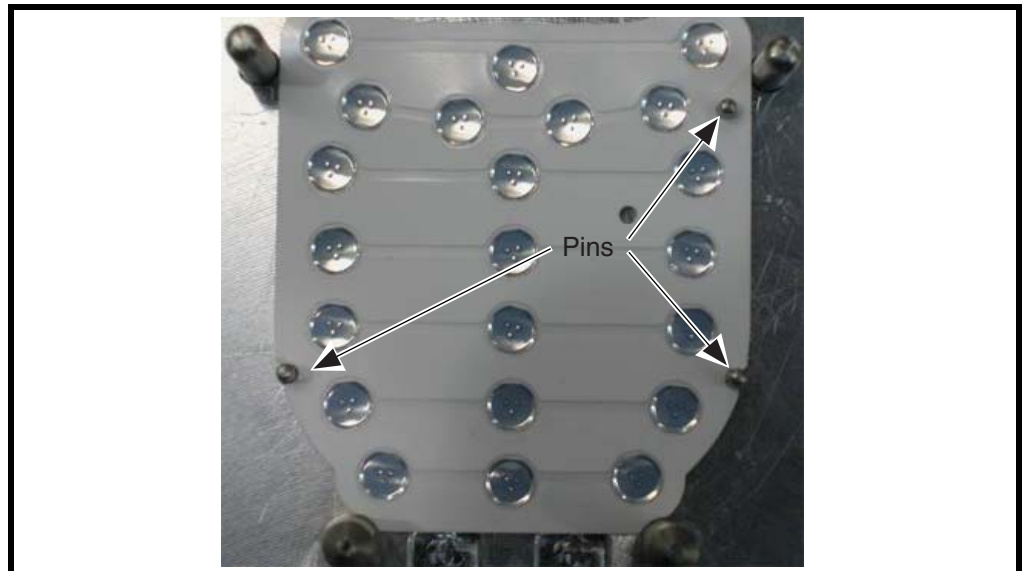

v562901

**Figure 60. Inserting the Dome Array to the Alignment Fixture**

3. Blow off the mylar with de-ionized air.
4. Blow off the PCB with de-ionized air.

5. Place PCB on alignment fixture and press down onto dome array/light sheet.



v562902

**Figure 61. Inserting the PCB onto the Dome Array Alignment Fixture**

6. Remove the PCB and inspect the dome array/light sheet alignment. Gold pads should be visible

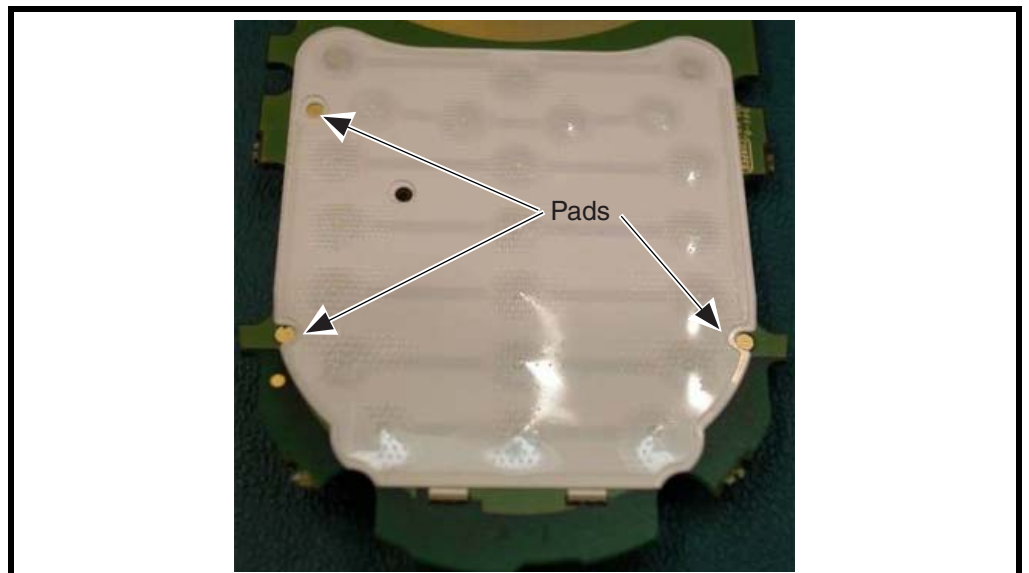

v562903

**Figure 62. Inserting the Dome Array to the Alignment Fixture**

7. Place the PCB in the mylar press fixture, 2897, and press the dome array/light sheet for 30 PSI and 7 seconds.
8. Peel off the light blocking mylar from the sheet.

- Align the posts on the mylar fixture to the holes in the top liner.

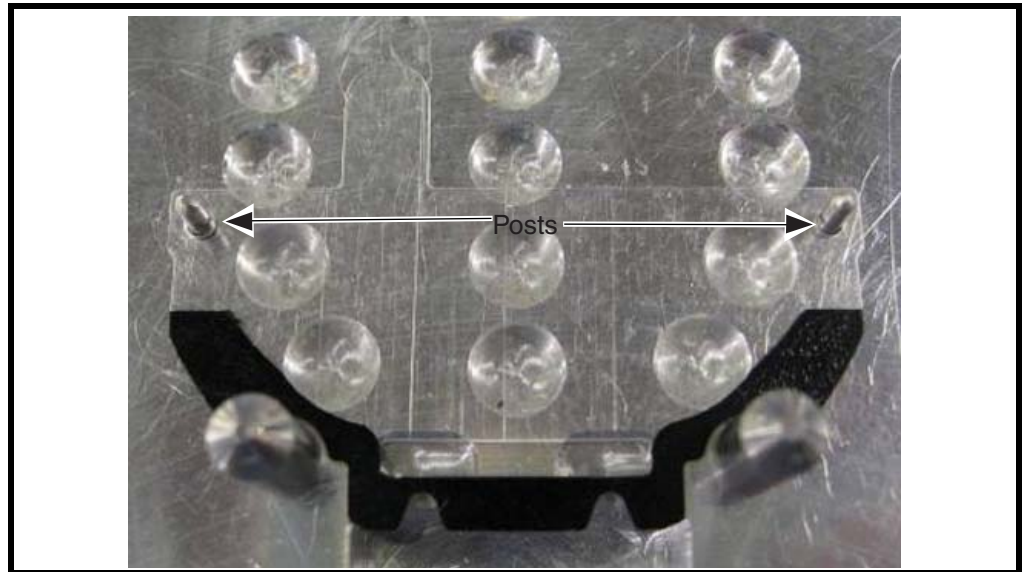

v562904

**Figure 63. Aligning the light Blocking Mylar to the Fixture Posts**

- Repeat Step 5.
- Remove the top liner.
- Press along the light blocking mylar to set the adhesive.

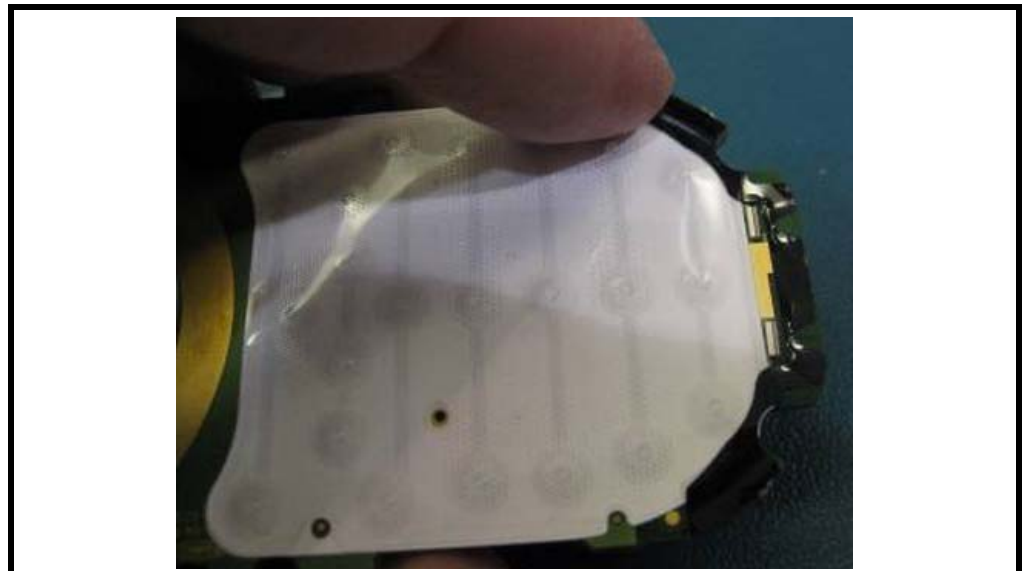

v562905

**Figure 64. Setting the light Blocking Mylar Adhesive**

### PCB Assembly: Liquid Detection Label (LDL) Placement

1. Place 3 LDL's as indicated in Figure 65.

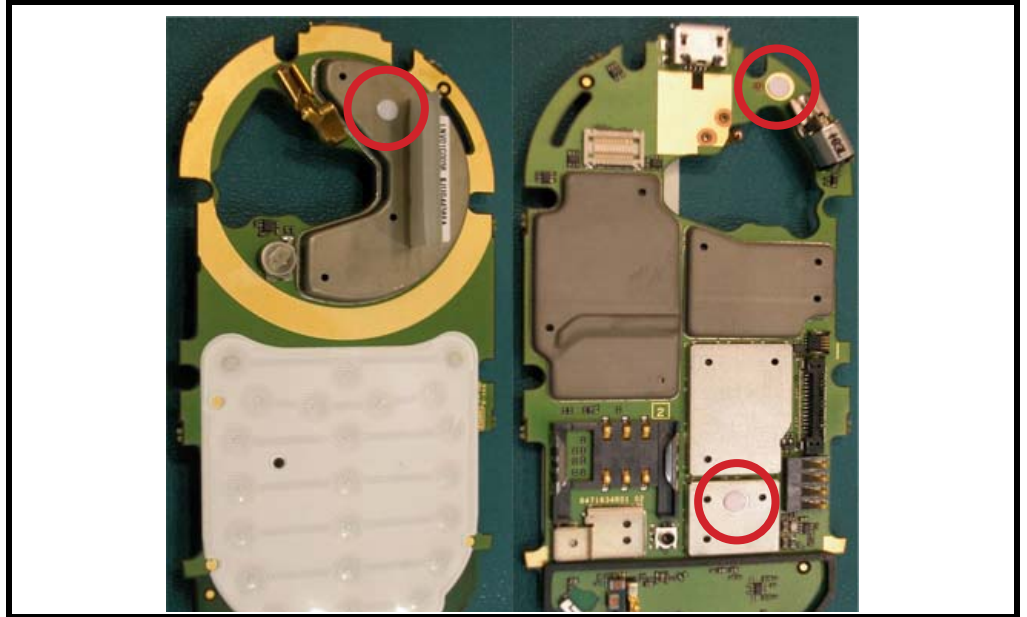

v562905

Figure 65. Placing the Liquid Detection Labels

### PCB Assembly: Assemble Acoustic Seal

1. Remove acoustic seal & clear top liner from the adhesive sheet.

2. Place the acoustic seal & top liner on the alignment fixture.



v562907

**Figure 66. Placing the Acoustic Seal and Top Liner on the Alignment Fixture**

3. Place the PCB on alignment fixture and press down onto the acoustic seal. Remove the PCB from the fixture. If the clear liner does not stay with the fixture, remove the liner from the seal.

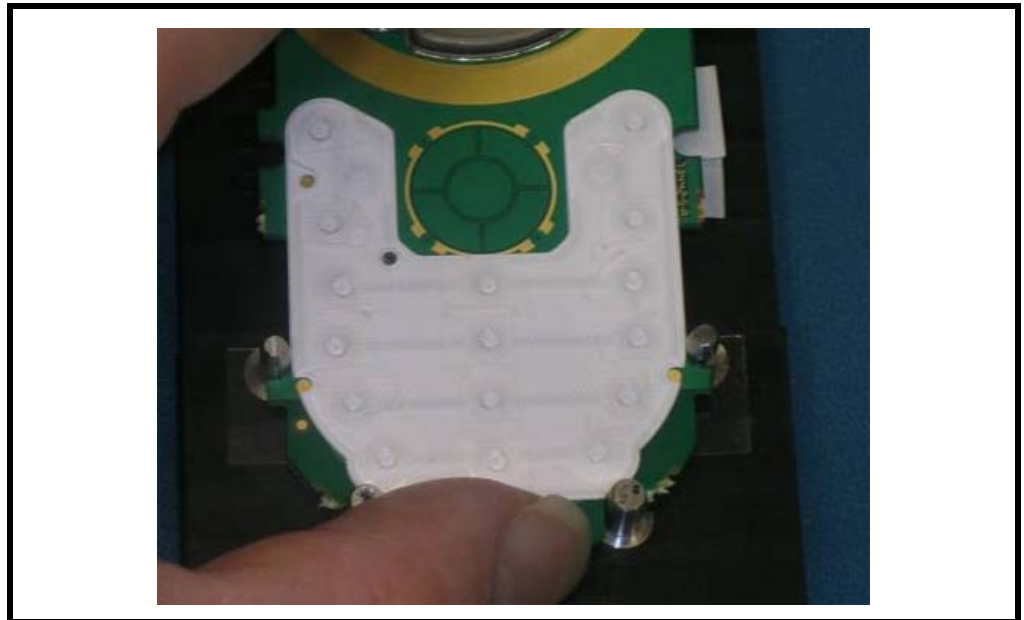

v562908

**Figure 67. Placing the PCB onto the Acoustic Seal**

4. Press the seal to the PCB to set the adhesive. Take care to avoid pressing on PCB components & the spring contacts.

### PCB Assembly: Assemble USB Seal

1. Place USB grommet over connector so the top edge goes under the top of the connector.

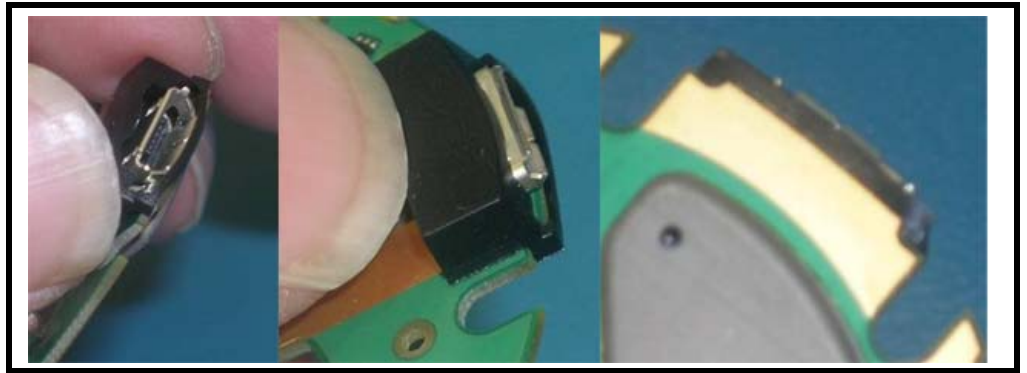

v562909

**Figure 68. Placing the PCB onto the Acoustic Seal**

2. Rotate the grommet over so it sits over top of the connector body.
3. Check the bottom side of the PCB to ensure the grommet is snapped over PCB edge.

### PCB Assembly: Imager Flex Assembly

1. Inspect the imager to ensure the grommet is on imager barrel correctly. Two grooves fit over two posts on imager.

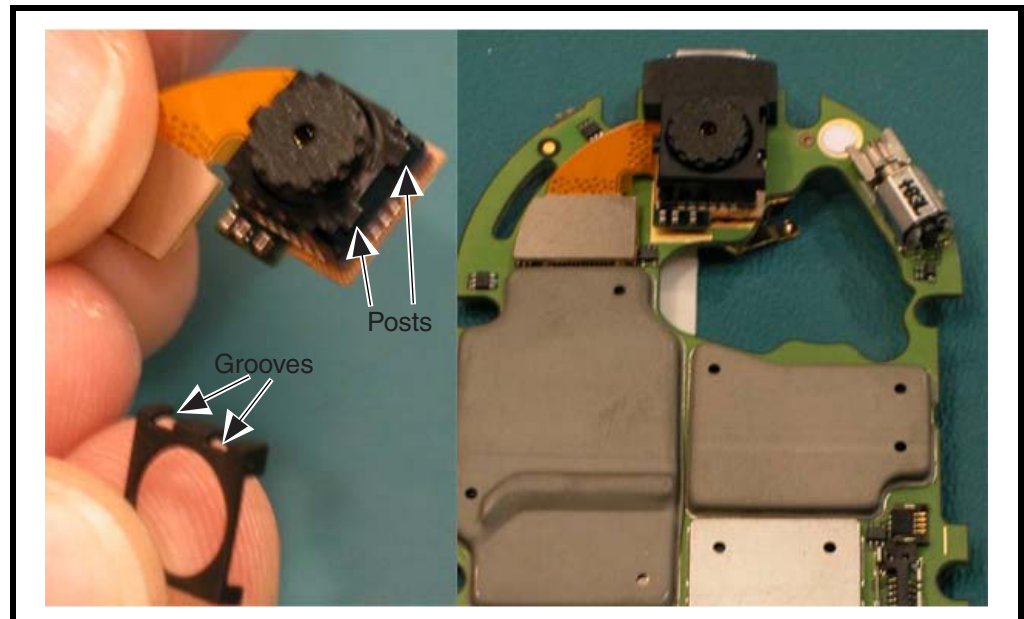

v562910

**Figure 69. Placing the Imager Flex Assembly onto the PCB**

2. Align and mate the imager flex board to board connector to the connector on the PCB.
3. Press on connector to ensure proper engagement.

### PCB Assembly: Side Key Flex Assembly

1. Lift up door on ZIF connector.
2. Align the side key flex tail to the ZIF connector slot.



3. Insert side key flex tail. Push in until white line on flex tail aligns to gold line on PCB.

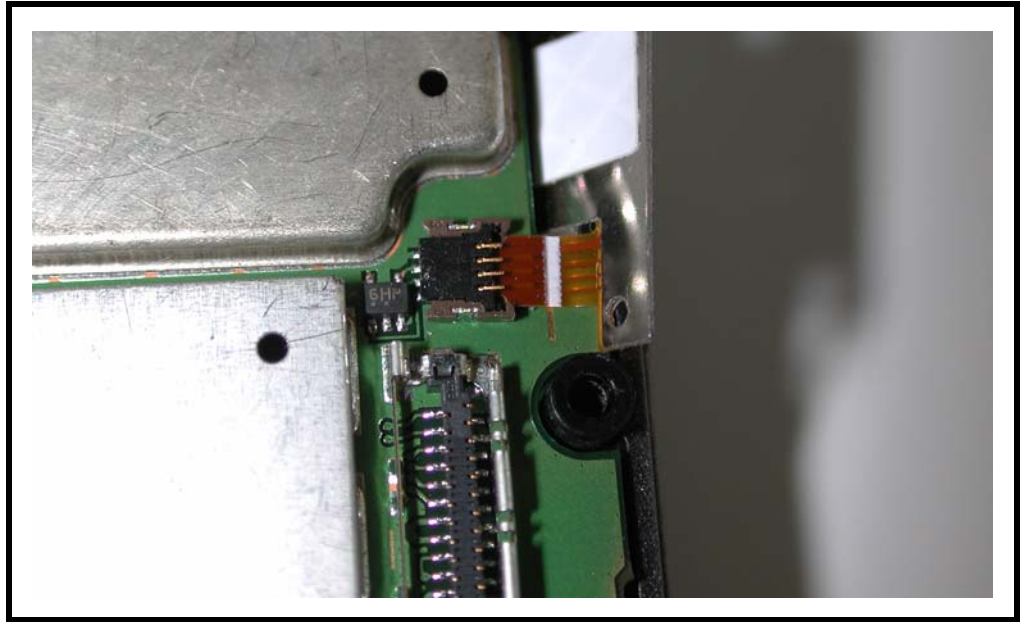

v562962

**Figure 70. Inserting the Side Key Flex Tail**

4. Press down on the ZIF connector door. There should be positive feedback that the door is closed.
5. Place pre-cut Kapton tape on top of ZIF connector.

### **PCB Assembly: Memory Shield Pressure Sensitive Adhesive (PSA)**

1. Remove memory shield PSA from the liner sheet.
2. Locate the alignment markings on the memory shield.



### PCB Assembly: Detent Bearing-Slider Assembly

1. Squeeze out a little Nyogel 744 from the tube. Bring the tip of the tube close to the curved portion of the detent clip. Transfer a small amount of lube to the contact. Do not get lubricant on the contact point.

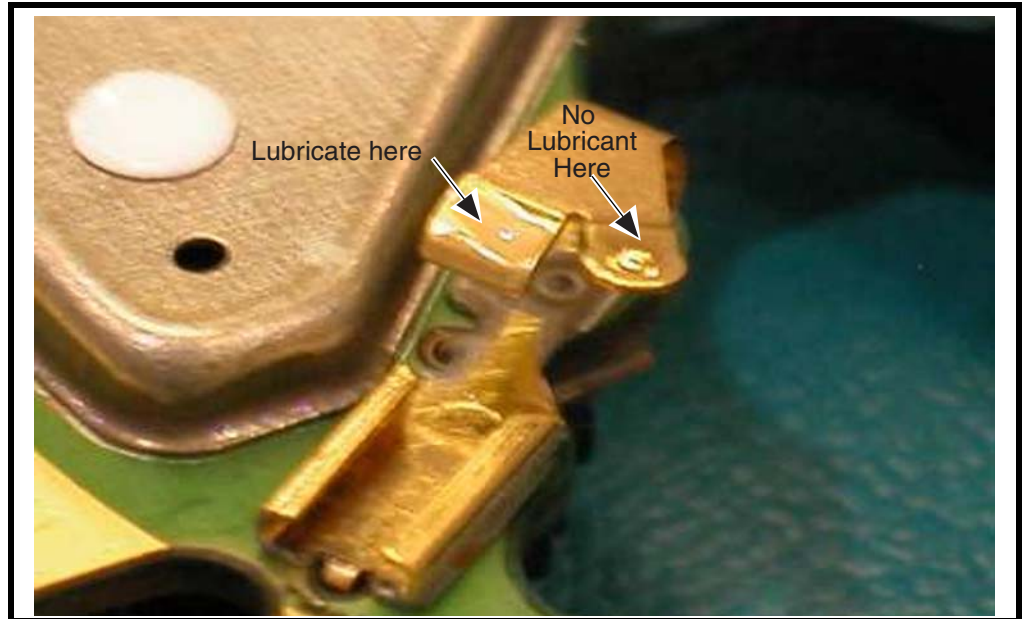

v562964

Figure 72. Lubricating the Detent Clip

2. Grasp the bearing-slider and align the base to the track on the detent clip.

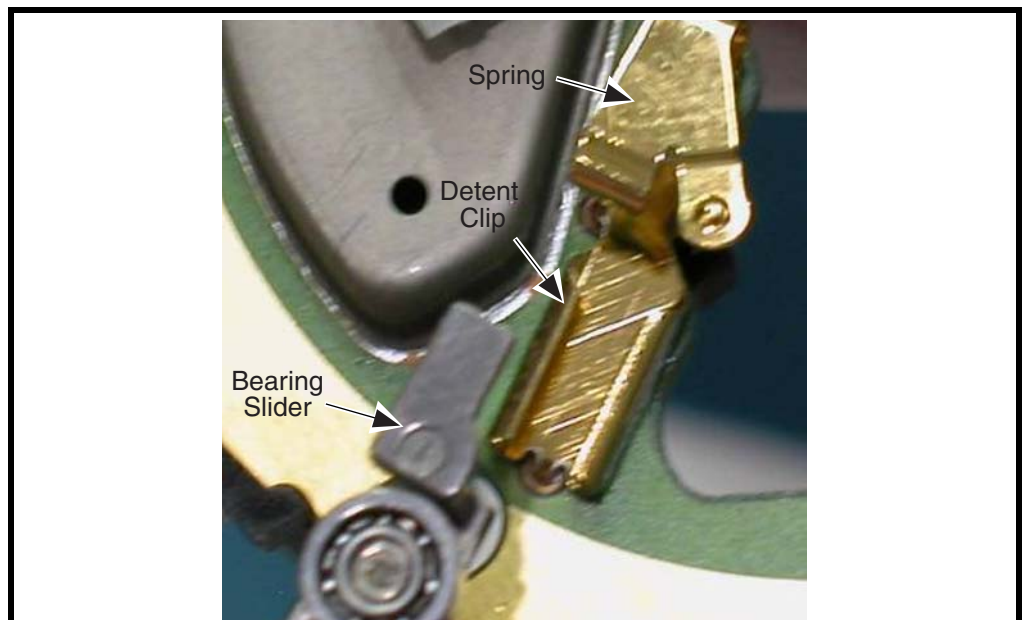

v562965

Figure 73. Installing the Detent Bearing-Slider Assembly

3. Push the bearing-slider into the track.
4. Depress the detent clip spring and push the bearing-slider in such that the tail of the bearing-slider fits over the spring. The upward force of the spring will keep the bearing-slider in place. Push the slider all the way in.

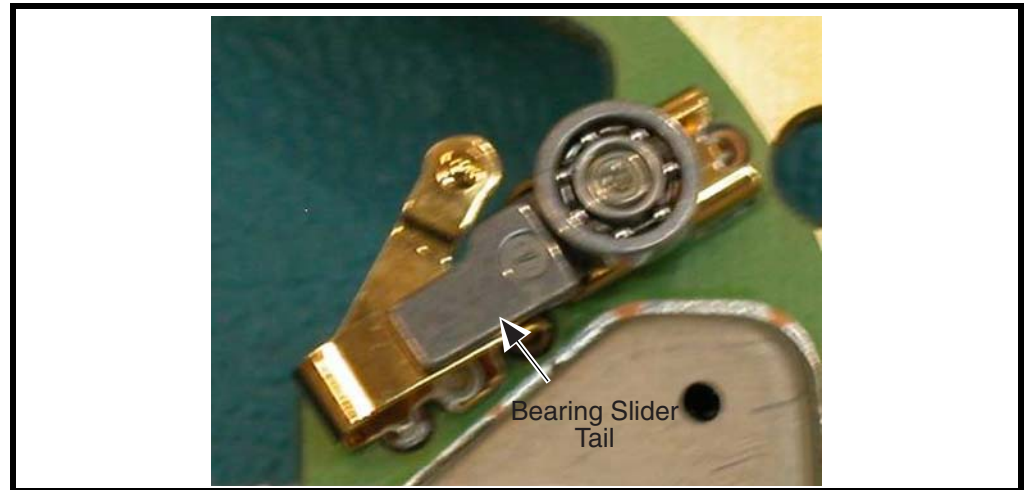

v562966

**Figure 74. Installing the Detent Bearing-Slider Assembly**

5. Apply another small amount of lube to the channel of the clip in front of the slider.



v562966

**Figure 75. Installing the Detent Bearing-Slider Assembly**

6. Place your fingernail against the end of the channel of the clip. Push the bearing slider outward till it stops against the nail. This is the position the slider should be assembled in.



v562968

**Figure 76. Pushing the Detent Bearing-Slider Assembly**

### Backlash Grommet

1. Place a short protective cap on the coax connector.

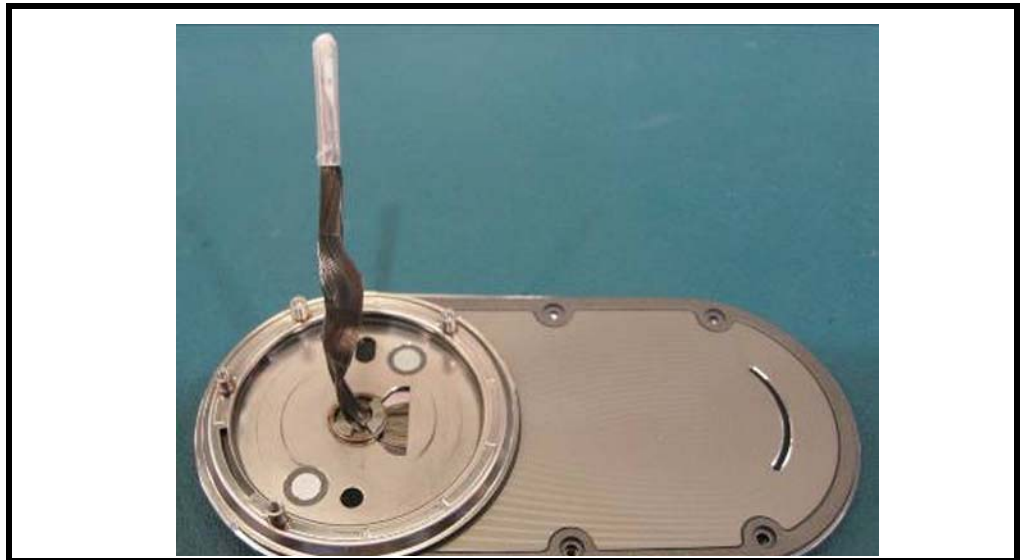

v562969

**Figure 77. Protecting the Coaxial Connector**

2. Align the grommet with the 3 prongs facing down to the protective cap.

- Carefully push the grommet over the cap.

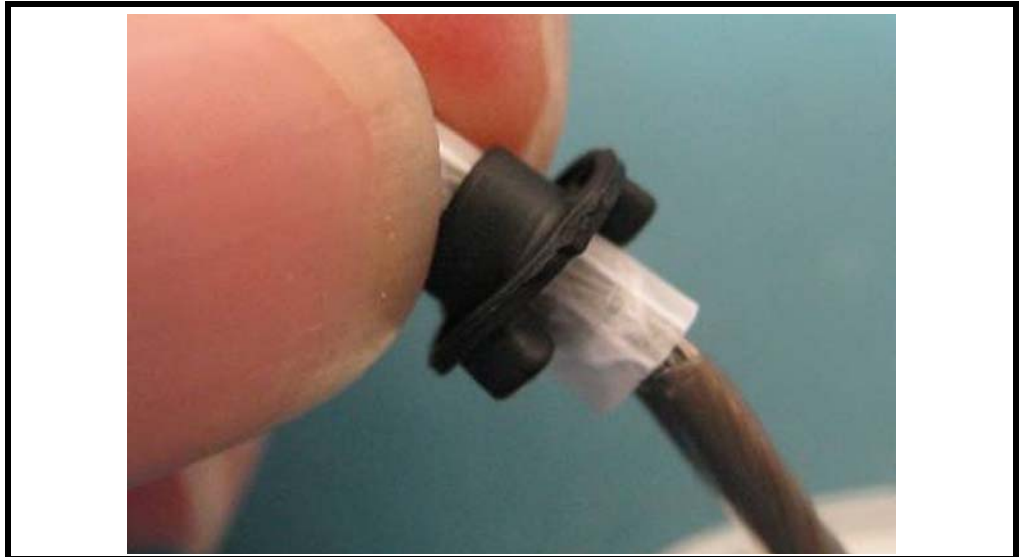

v562970

**Figure 78. Pushing the Grommet over the Protective Cap**

- After the grommet clears the cap continue pushing the grommet down over the coax. Insert the grommet prongs into the coupler recesses. Ensure all 3 prongs are completely inside the recesses.



v562971

**Figure 79. Inserting the Grommet into the Coupler Recesses**

- Remove the short protective cap and insert a long protective cap.

6. Push the long protective cap all the way down to the grommet. Use the cap to hold the grommet in place during handling and assembly.

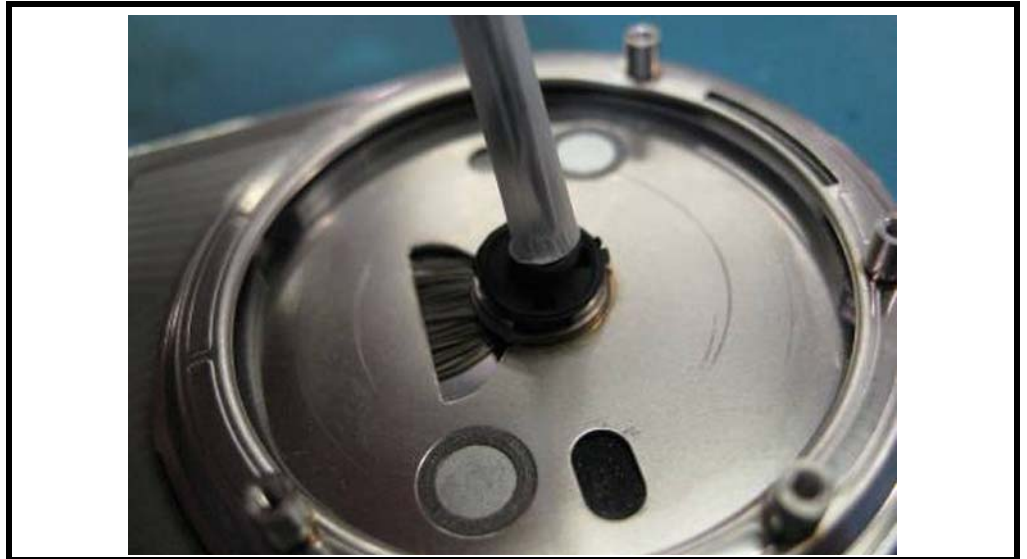

v562972

**Figure 80. Using the Long Protective Cap**

### Front Housing Assembly

1. Guide the micro-coax transceiver connector through the opening in the front housing assembly.

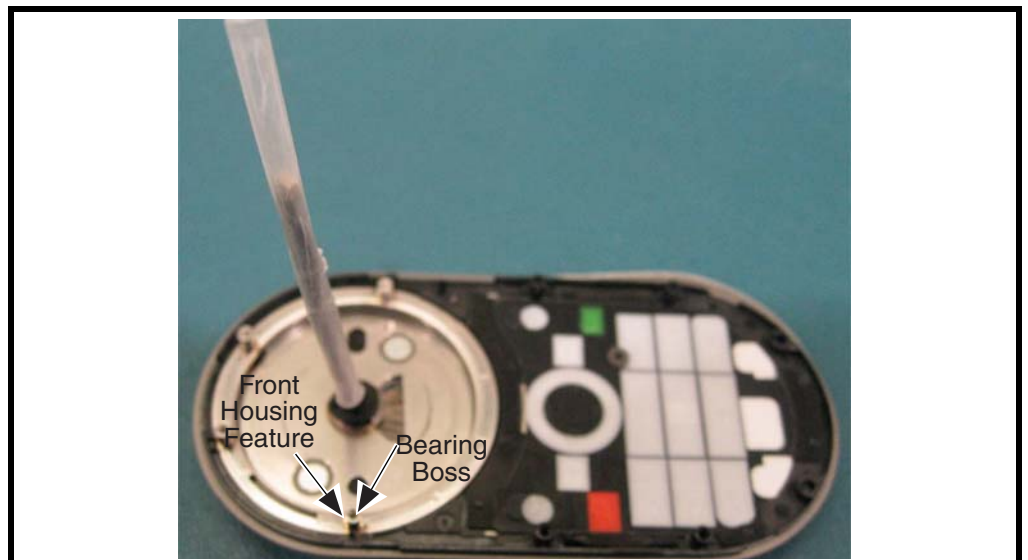

v562973

**Figure 81. Assembling the Front Housing**

2. Place the front housing assembly onto the blade assembly.

3. Rotate the bearing race so the bosses line up with the features in the front housing.

### Place PCB Assembly

1. Guide micro-coax transceiver connector through the opening in the PCB.

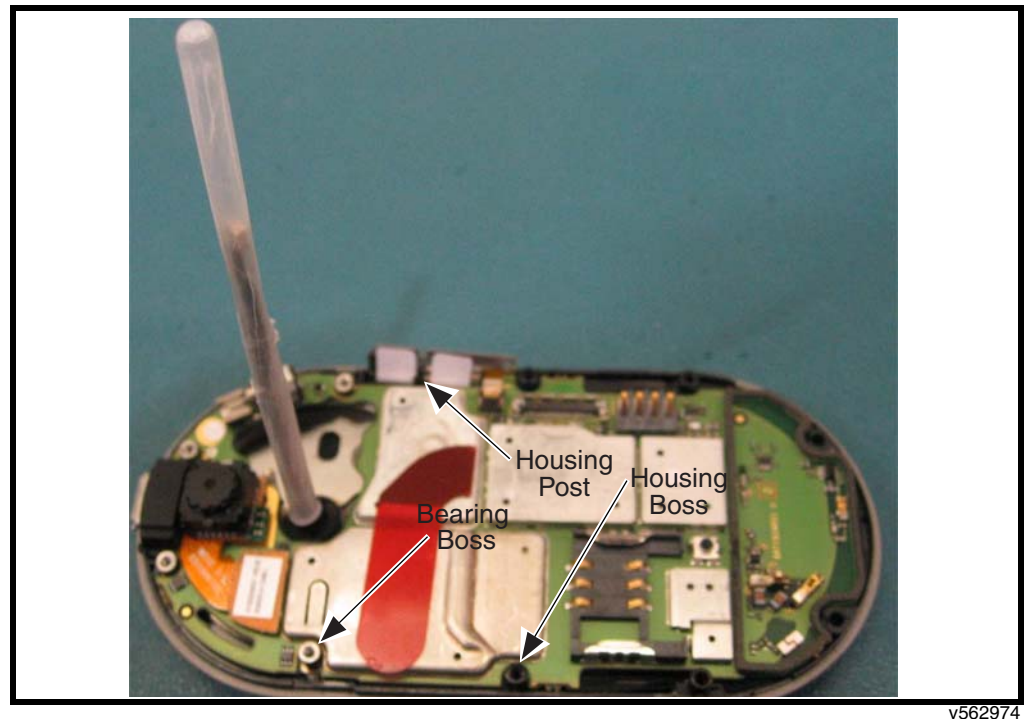

**Figure 82. Assembling the PCB**

2. Place PCB assembly on the front housing aligning the screw bosses on the front housing and bearing to PCB notches.
3. Align the side key flex to the outside of the vertical post on the front housing.



---

### Hinge Module Assembly

1. Verify the hinge timing lock is in place.

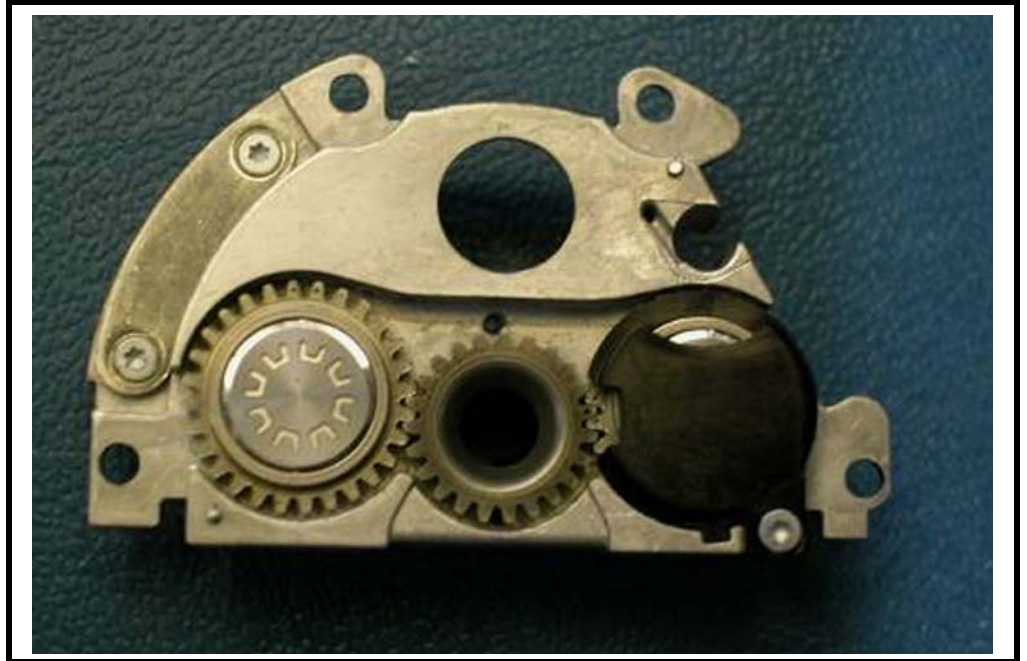

v562975

Figure 83. Verifying the Hinge Timing Lock

2. Verify the imager backer pad is in place.

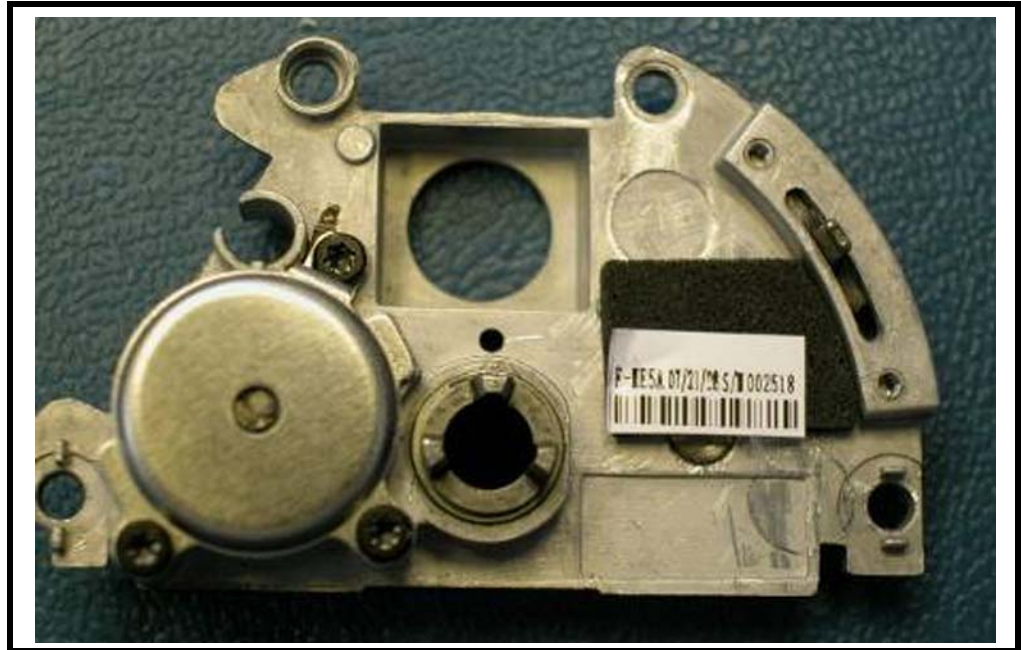

v562976

**Figure 84. Checking the Image Backer Pad**

3. Insert the detent torsion spring into the hole in the housing. The long straight arm should be aligned to the slot in the gear housing.

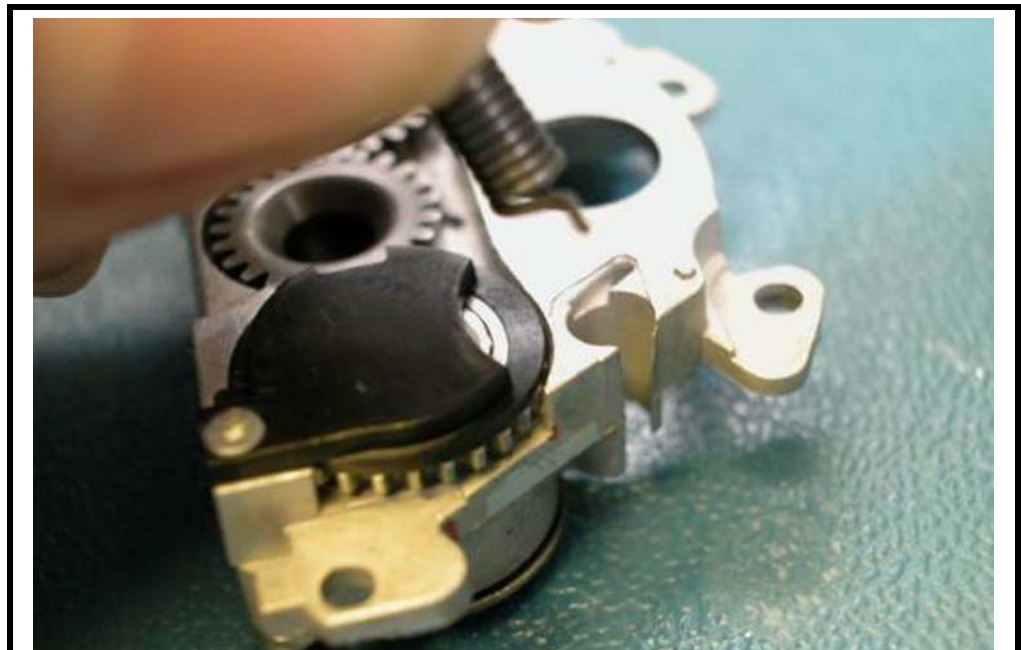

v562977

**Figure 85. Assembling the Torsion Spring**

4. Rotate the spring so the spring arm is against the hinge housing.



**Figure 86. Hinge Module Assembly**

v562978

5. The lock arm of the spring should appear as in Figure 86.

### Assemble Hinge Module to Phone

1. Press down on the protective cap to keep the grommet pressed into the coupler. Align and insert the protective cap into the hinge module center gear.

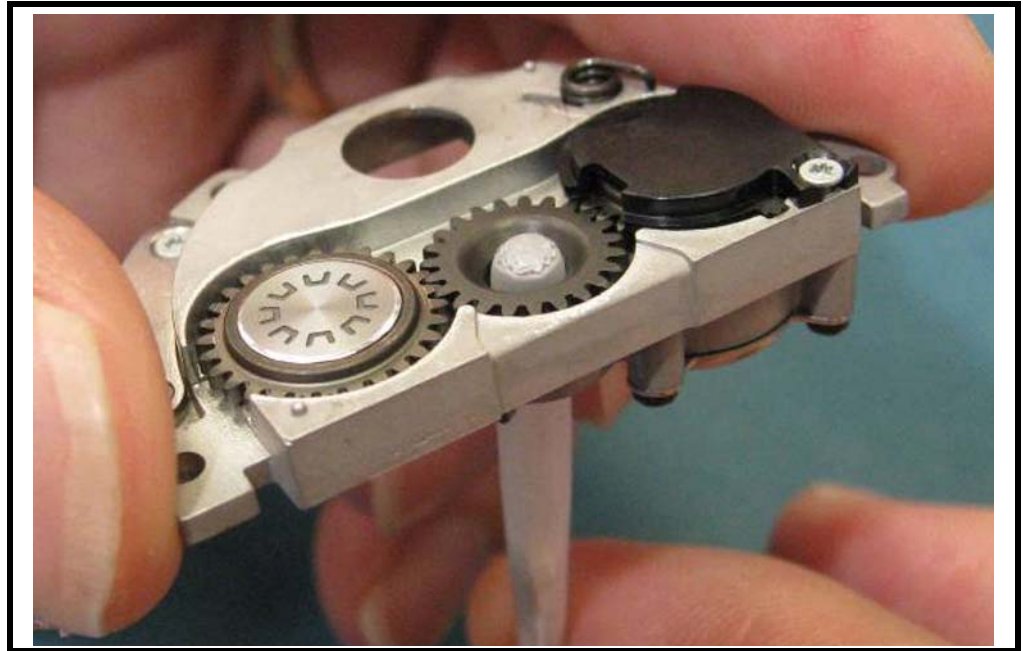

v562979

**Figure 87. Assembling Hinge Module Assembly to Phone**

2. Keeping the pressure on the cap, push the hinge module down over the protective cap.
3. Continue pushing the coax through the center gear and drop the module onto the PCB. Ensure the imager fits into the recess in the gear housing and the USB water seal is not dislodged. The module should sit on the bearing bosses. Press the hinge module down to ensure the center gear prongs engage with the grommet. Ensure the detent spring has remained in position. Do not touch the imager barrel as this may cause smudging or finger prints.

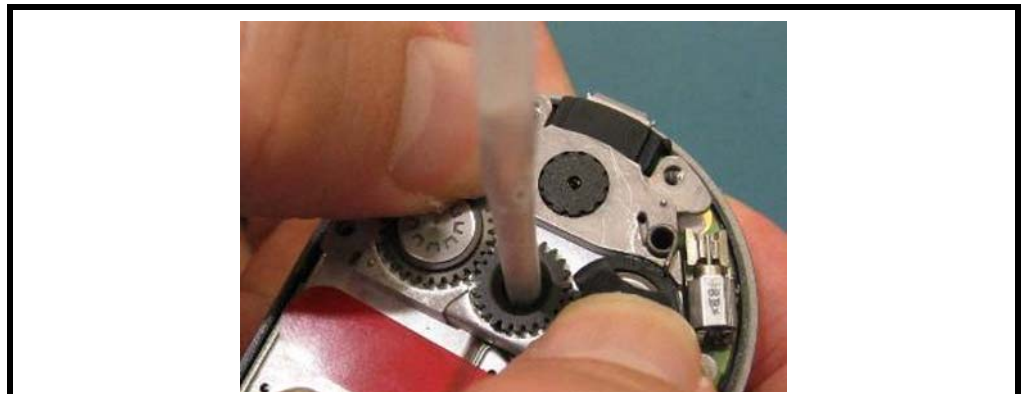

v562980

**Figure 88. Lowering the Hinge Module Assembly to PCB**

4. Remove the protective cap from the coax connector, straighten out the coax and align the connector to the PCB connector. Partially mate the connector. Make sure the coax is flat against the PCB shields.

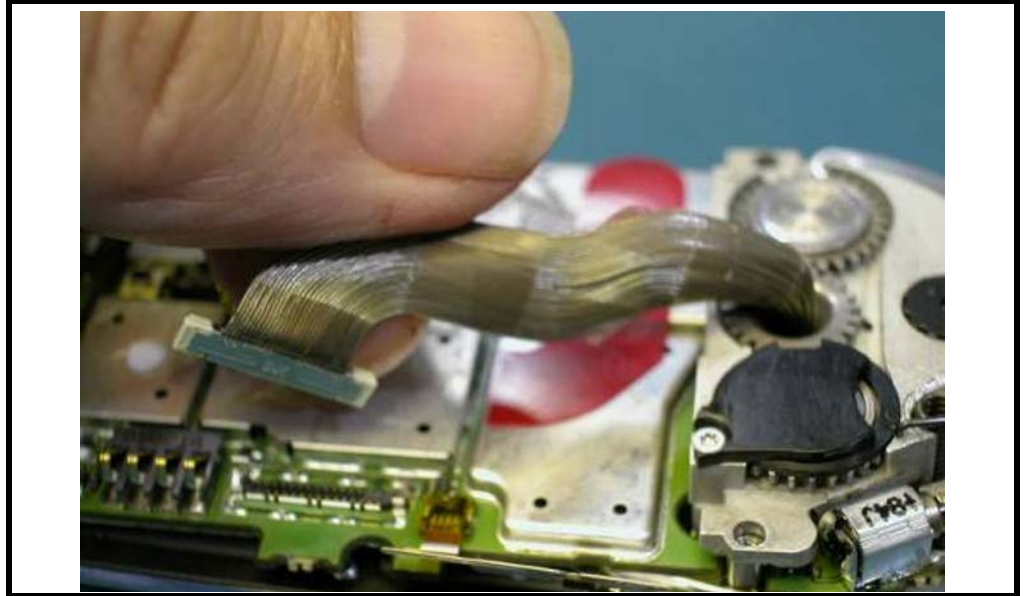

v562991

**Figure 89. Straightening the Coax**

5. Place the unit in the press fixture and press the connector at 25 PSI for 5 seconds.

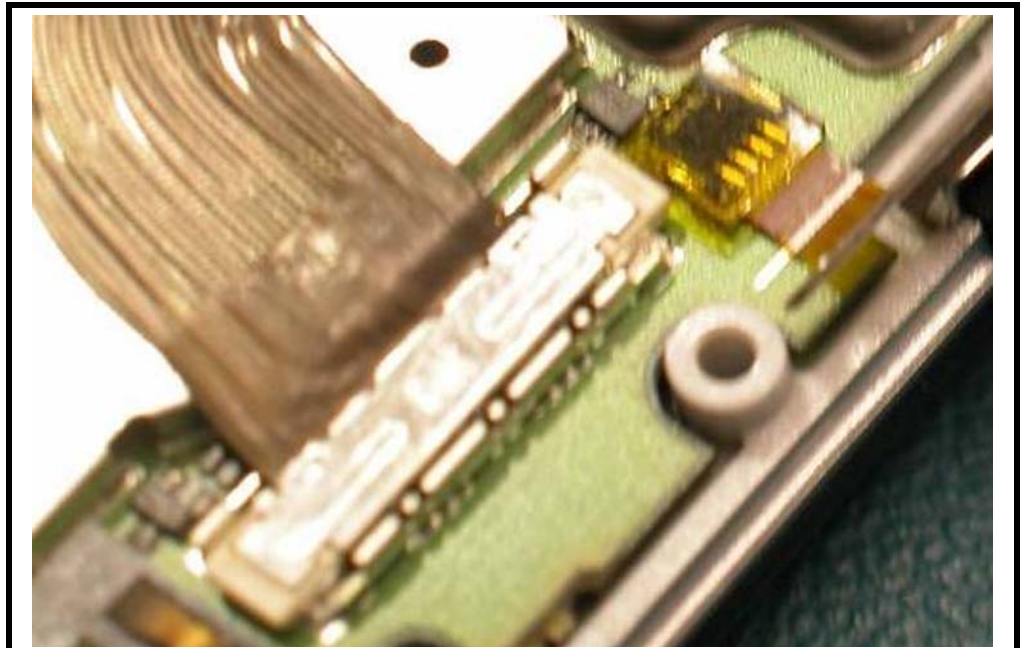

v562992

**Figure 90. Pressing the Coaxial Connector**

6. Remove the liner from the memory shield PSA.

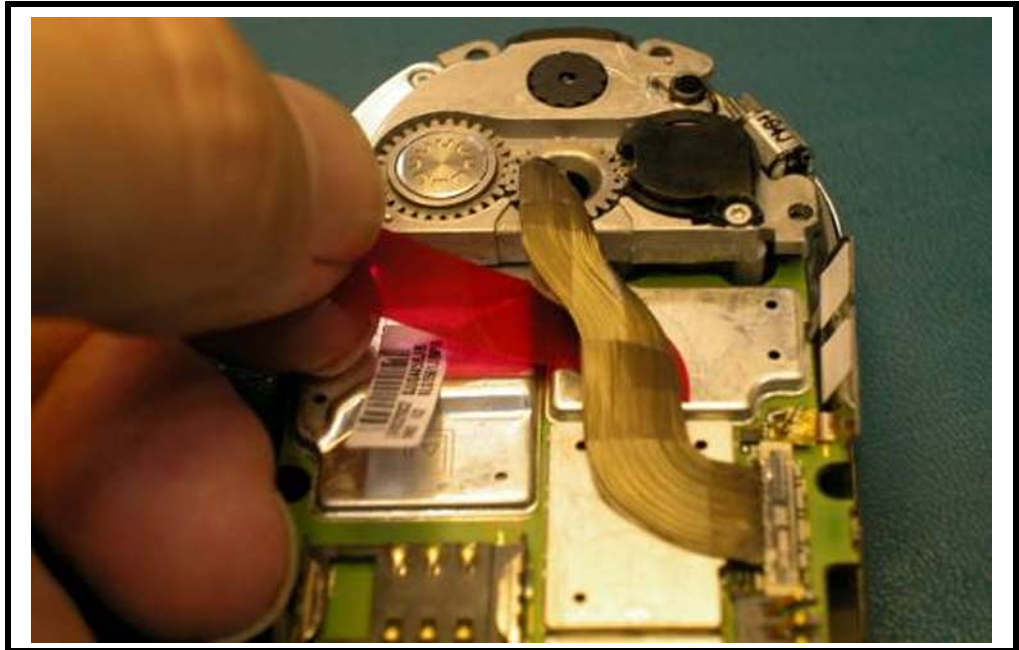

v562993

**Figure 91. Removing the Liner from the Memory Shield PSA**

7. Starting at the connector, run a finger up the coax to press the coax down to the shields. On the memory shield ensure the coax sticks to the PSA.



v562994

**Figure 92. Adhering the Coax Assembly to Memory Shield**

8. Inspect the coax to ensure it is lying flat against the shields and is centered coming out of the center gear of the hinge module.



v562995

**Figure 93. Inspecting the Coax Assembly**

### **Assemble the Rear Housing Assembly**

1. Inspect rear housing and ensure all the antenna heat stakes are staked.
2. Remove the adhesive liner from the inside of the antenna cap.

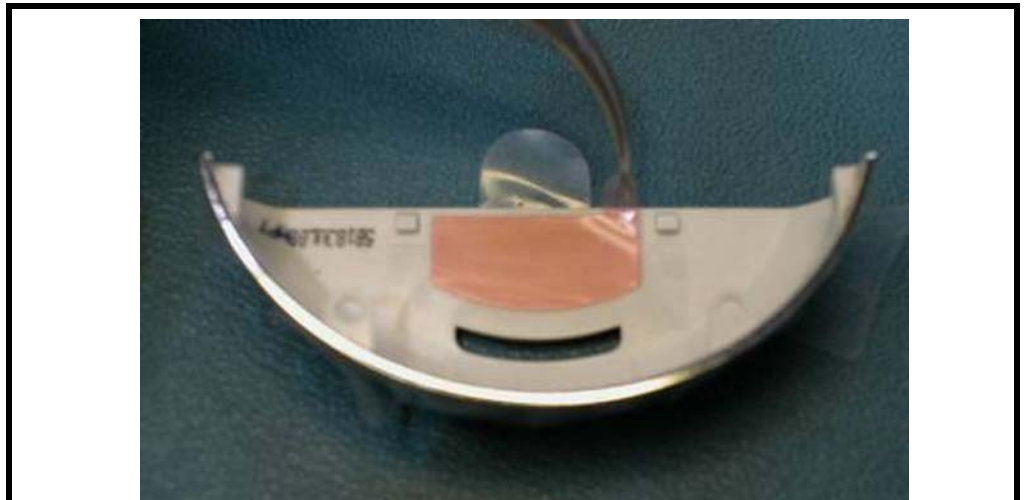

v562996

**Figure 94. Removing the Antenna Cap Adhesive Liner**

3. Align the antenna cap to the bottom of the rear housing. Push the snap features on the housing and ensure the screw bosses are lined up properly. Push the antenna cap onto the housing in the direction indicated.

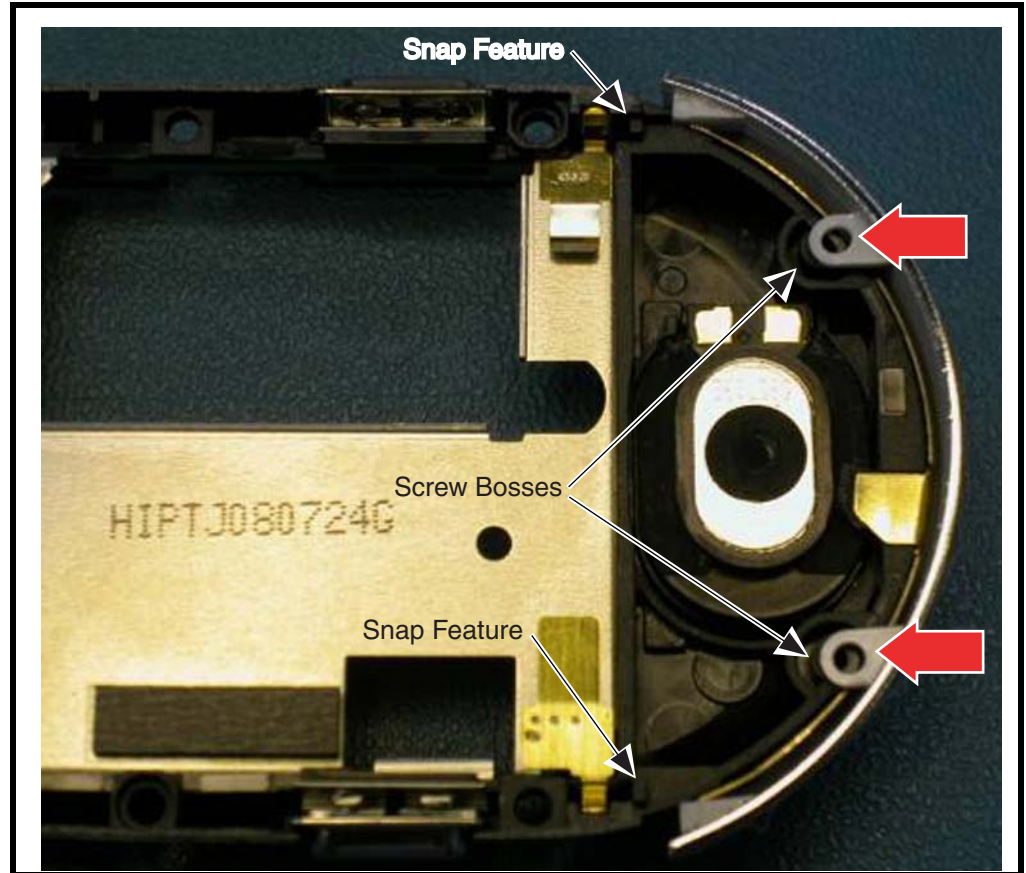

v562997

Figure 95. Installing the Antenna Cap



4. Turn the rear housing over and ensure the top snaps are properly engaged with the rear housing.

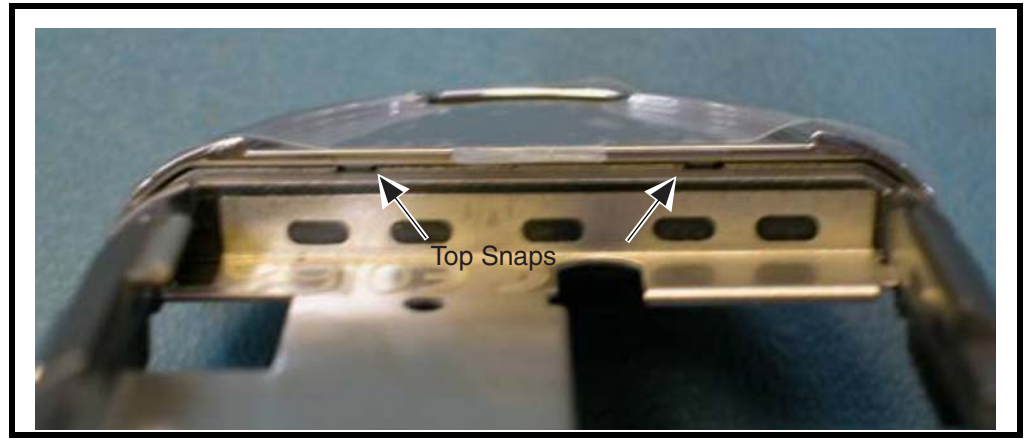

v562998

**Figure 96. Checking the Top Snaps**

5. Place the side key button into the front housing. The rounded edges of the button should face up.

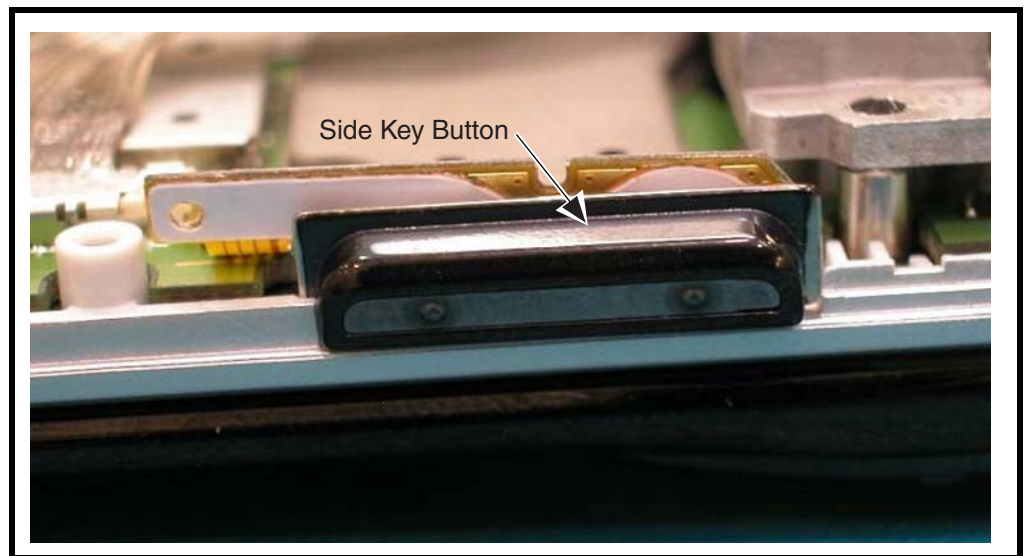

v562999

**Figure 97. Placing the Side Key Button**

6. Place the rear housing onto the assembly such that it captures the side key button. Ensure the side key flex is in front of the wall on the rear housing. DO

NOT PINCH THE FLEX. While holding down the rear housing check the side key for tactile feedback for up and down direction.

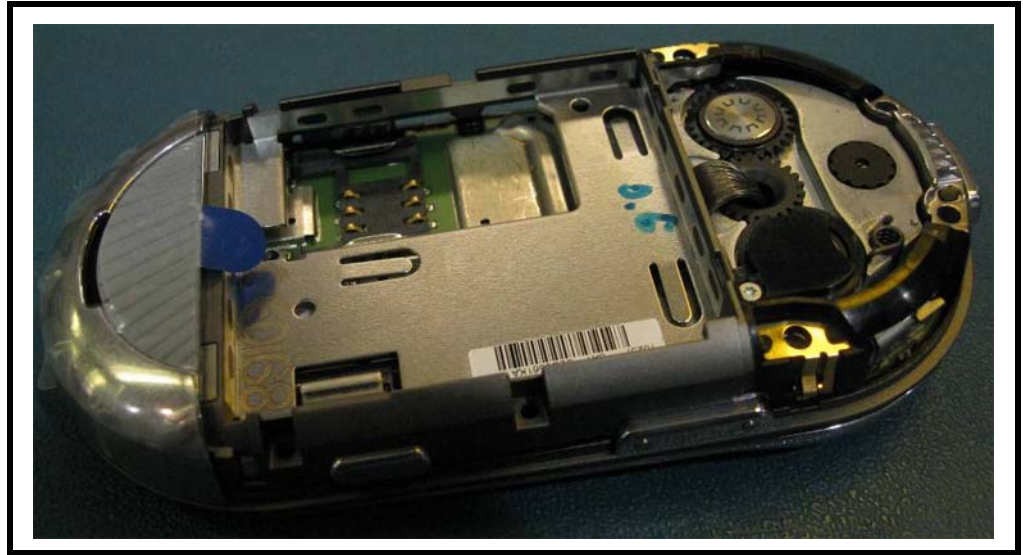

v563000

**Figure 98. Placing the Rear Housing**

7. Position the rear housing onto the assembly aligning the housing around the hinge module.
8. Drive the 4 rear housing screws in the sequence indicated using a T4IP bit with a torque driver at 1.0 in-lbs.

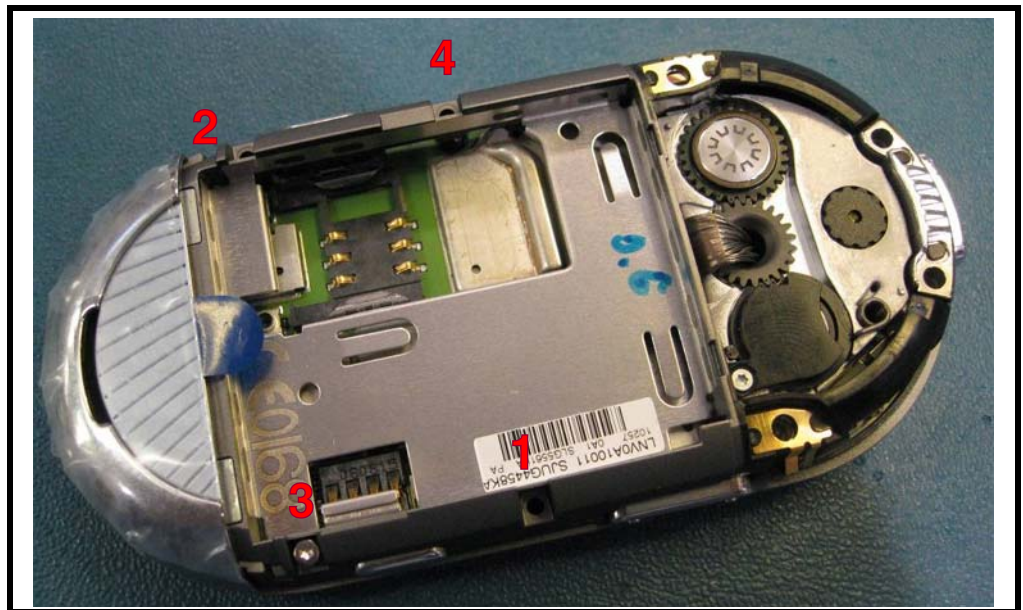

v563035

**Figure 99. Driving the Rear Housing Screws**

9. Check the side key for tactile feedback.

### Set Detent Torsion Spring

1. Use the torsion winding tool or a flat tip screw driver to lift the lock arm of the detent spring. Rotate the lock arm toward the locking position slot. Be careful not to allow the tab on the lock arm to drag across the decorated surfaces of the gear.

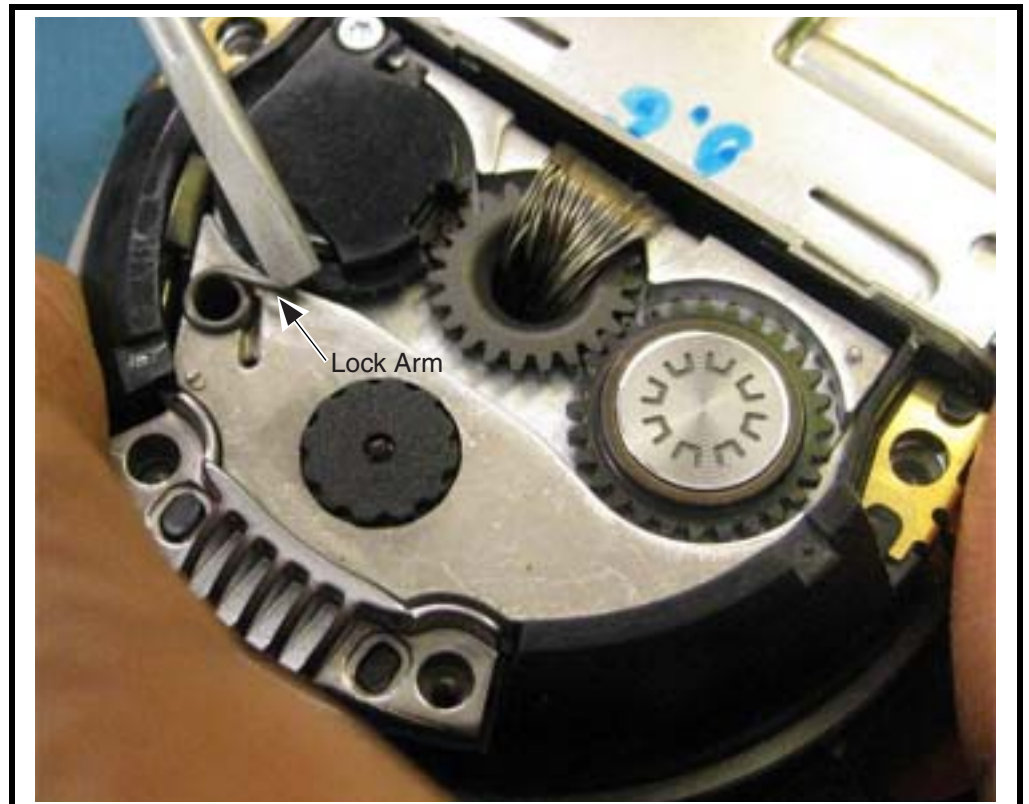

v563036

Figure 100. Setting the Detent Torsion Spring

2. Push the lock arm into the locking position slot. Ensure the arm drops completely into the slot. All parts of the spring must be below the surface of the hinge module.

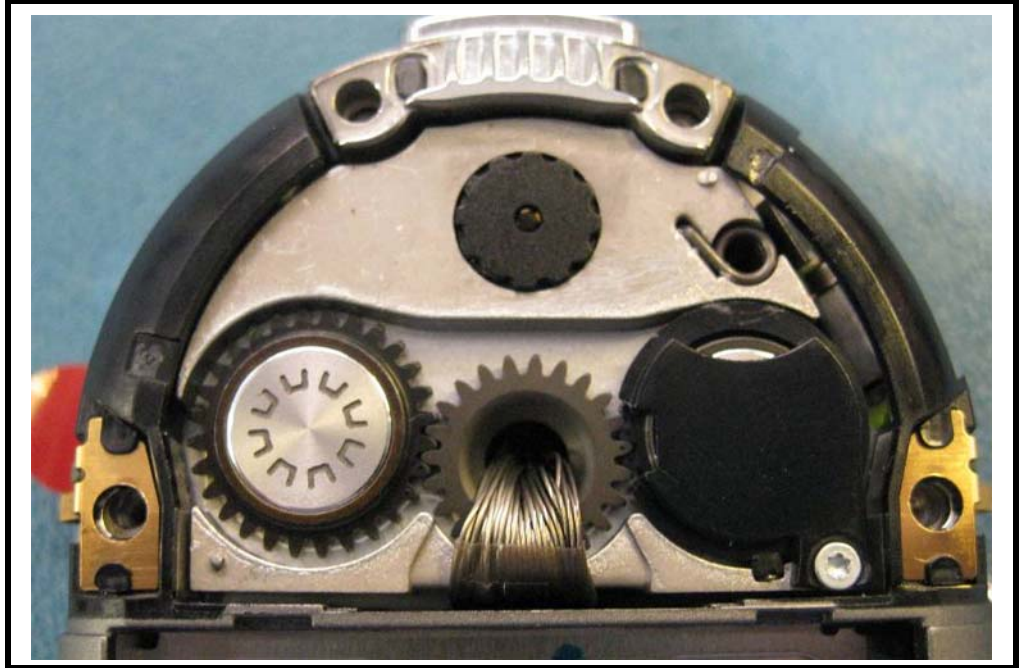

v563037

Figure 101. Positioning the Lock Arm

### Place the Hinge Bezel

1. Use a T3 driver to remove the timing lock screw and remove the plastic lock.



v563038

Figure 102. Removing the Timing Lock Screw

2. Locate the bezel alignment posts on the hinge module. Do not touch the imager barrel as this may cause smudging or finger prints on the lens.

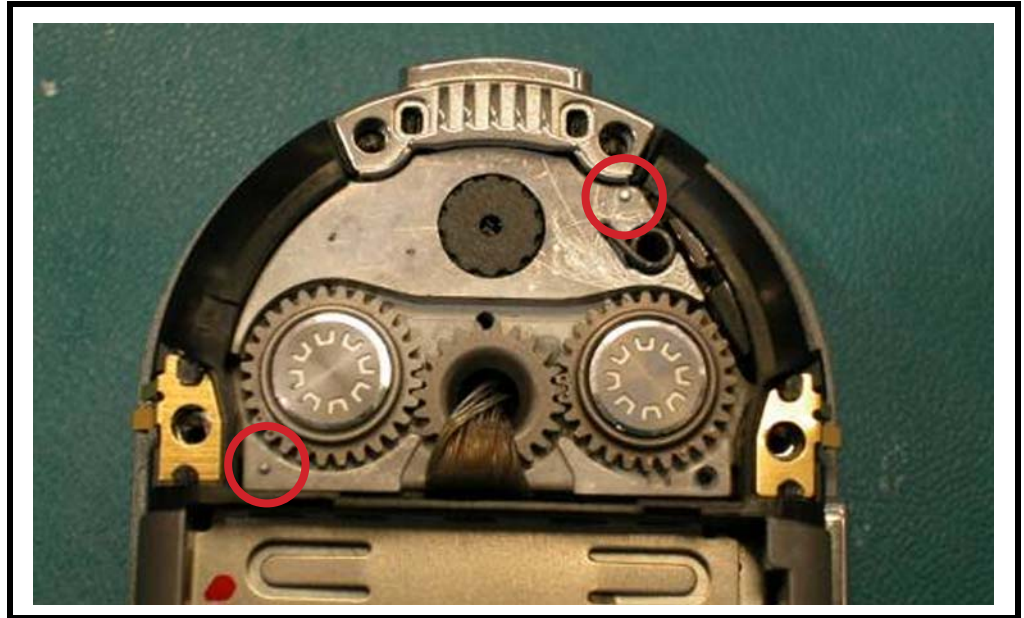

v563039

**Figure 103. Locating the Bezel Alignment Posts**

3. Remove the hinge bezel from the adhesive liner. Align the hole in the bezel to the post in the lower left corner of the module.



v563040

**Figure 104. Attaching the Hinge Bezel**

4. Align the slot in the bezel to the alignment post in the upper right side on the hinge module. Press down on the bezel to set the PSA.
5. Inspect for proper alignment of the bezel around the imager and gears.

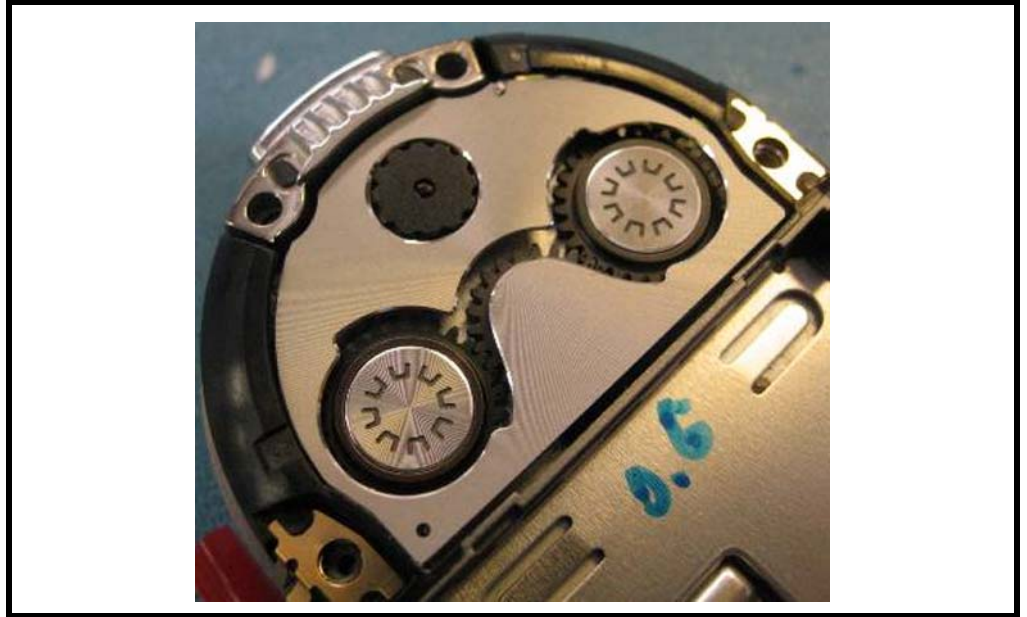

v563041

**Figure 105. Inspecting the Hinge Bezel**

### **Place the Top Cap Assembly**

1. Remove the internal lens liner from the top cap assembly. Check the lens for smudging, finger prints or other cosmetic defects.
2. Blow out the lens with de-ionized air.
3. Blow off the hinge bezel and imager with de-ionized air.

4. Place the top cap assembly onto the rear housing.



v563042

**Figure 106. Placing the Top Cap onto the Rear Housing**

5. Ensure the gold contacts on the rear housing assembly pop out through the windows on the top cap.



v563043

**Figure 107. Checking the Grounding Contacts on the Rear Housing**



6. Drive the 4 top cap assembly screws in the sequence indicated using a T6IP bit with a torque driver at 1.6 in-lbs.

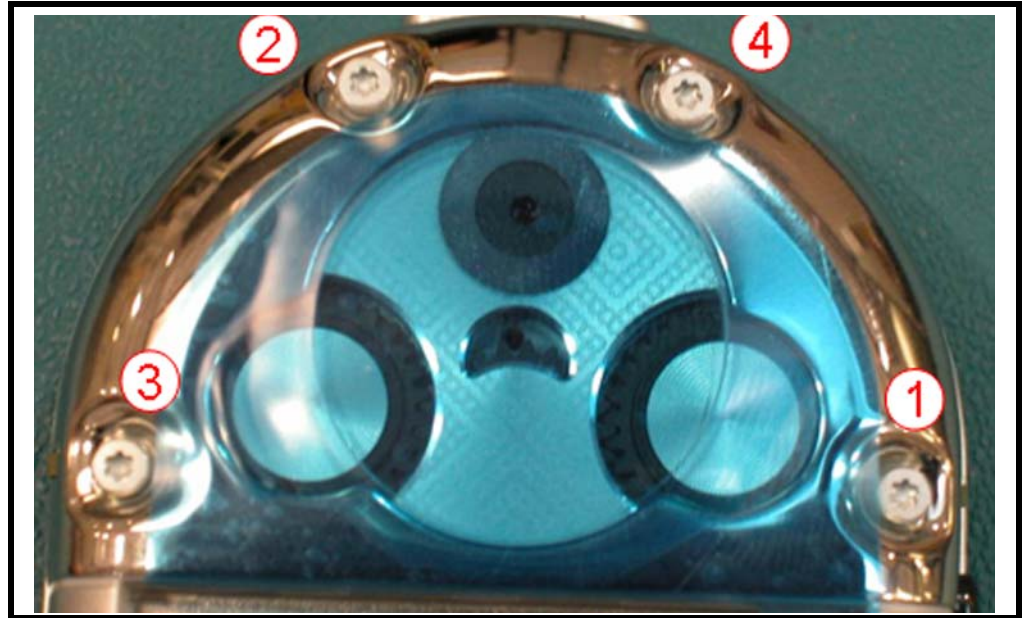

v563044

Figure 108. Driving the Top Cap Assembly Screws

### Cycle the Blade

1. Open the blade in the clockwise direction to verify hinge operation. Close the blade.
2. Open the blade in the counter-clockwise direction. Close the blade.
3. Repeat several times. Ensure the blade opens freely in both directions.
4. Check that the detent is working by verifying the blade is held solidly in the open and closed positions.

### Install the Antenna Cover Screws

1. Open the blade.

2. Drive the 2 antenna cap screws using a T4IP bit with a torque driver at 1.0 in-lbs.



v563045

Figure 109. Driving the Antenna Cap Screws

### Assemble the Transceiver Riding Surface

1. This operation should be done after all testing is completed.
2. Remove the adhesive liner from the riding surface.
3. Place the riding surface into the recess on the front housing. Ensure the post fits into the slot.
4. Place phone into the press fixture, 2991, and press the riding surface at 28 PSI for 6 seconds.
5. Inspect the part to ensure it is placed correctly.

### Final Assembly Steps

1. Replace the SIM, battery, and battery cover as described in the procedures.

## Subscriber Identity Module (SIM) and Identification

### SIM Card

A SIM is required to access the existing local GSM network, or remote networks when traveling (if a roaming agreement has been made with the provider).

The SIM contains:

- All the data necessary to access GSM services.
- The ability to store user information, such as phone numbers.
- All information required by the network provider to provide access to the network.

### Personality Transfer

A personality transfer is required when a phone is express exchanged or when the main board is replaced. Personality transfers reproduce the customer's original personalized details, such as menu and stored memory, such as phone books, or even just program a unit with basic user information, such as language selection. EM30 telephones use TrueSync® synchronization software to effect a personality transfer.

### Identification

Each Motorola GSM device is labeled with a variety of identifying numbers. The following information describes the current identifying labels.

#### Mechanical Serial Number (MSN)

The Mechanical Serial Number (MSN) is an individual unit identity number and remains with the unit throughout the life of the unit.

The MSN can be used to log and track a unit on Motorola's Service Center Database. The MSN is divided into 4 sections, as shown in Figure 110.

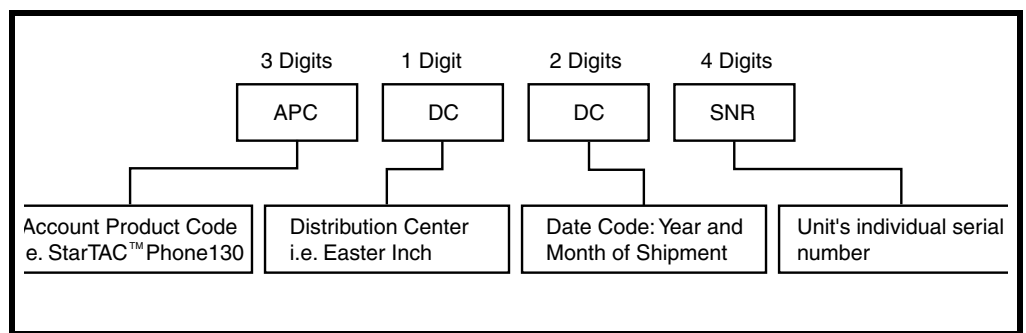

000807a

Figure 110. MSN Label breakdown

### International Mobile Station Equipment Identity (IMEI)

The International Mobile station Equipment Identity (IMEI) number is an individual number unique to the PCB and is stored within the unit's memory.

The IMEI uniquely identifies an individual mobile station and thereby provides a means for controlling access to GSM networks based on mobile station types or individual units. The full IMEI structure is listed in Table 3.

**Table 3. IMEI Number Breakdown**

TAC	Serial Number	Check Digit
NNXXXXXX	ZZZZZZ	A

Where

**TAC** Type Allocation Code, formerly known as Type Approval Code

**NN** Reporting body identifier

**XXXXXX** Type Identifier

**ZZZZZZ** Individual unit serial number

**A** Phase 1 = 0.

Phase 2 = check digit defined as a function of all other IMEI digits

Other label number configurations present are:



- **TRANSCIVER NUMBER:** Identifies the product type. Normally the SWF number. (i.e. V100).
- **PACKAGE NUMBER:** Identifies the equipment type, mode, and language in which the product is shipped.

# Troubleshooting

## Manual Test Mode

Aura telephones are equipped with a manual test mode capability. This allows service personnel to verify functionality and perform fault isolation by entering keypad commands.

To enter the manual test command mode, a GSM / DCS test SIM must be used.

1. Press  to turn the phone OFF.
2. Remove the battery as described in the procedures.
3. Remove the customer's SIM card from the phone as described in the procedures.
4. Insert the test SIM into the SIM slot.
5. Replace the battery as described in the procedures.
6. Press  to turn the phone ON.

## Manual Test Mode Commands

Table 4. Manual Test Commands

Key Sequence	Test Function/Name	Remarks
<Menu>048263*	Enter manual test mode	
"End" Key	Exit manual test mode	
54*	Suspend	Required for all Test Mode Operations
0*0*0	Select tone 0	
0*0*1	Select tone 1	
0*0*2	Select tone 2	
0*0*3	Select tone 3	
0*0*4	Select tone 4	
0*0*5	Select tone 5	
0*0*6	Select tone 6	
0*0*7	Select tone 7	
0*0*8	Select tone 8	
0*0*9	Select tone 9	
0*1*X	Disable tone X	
3*0*1	Enable vibrator	
3*0*0	Disable vibrator	
5*0*0	Set audio level 0	
5*0*1	Set audio level 1	
5*0*2	Set audio level 2	
5*0*3	Set audio level 3	
5*0*4	Set audio level 4	
5*0*5	Set audio level 5	
5*0*6	Set audio level 6	
5*0*7	Set audio level 7	

**Table 4. Manual Test Commands (Continued)**

Key Sequence	Test Function/Name	Remarks
5*0*8	Set audio level 8	
5*0*9	Set audio level 9	
5*0*10	Set audio level 10	
5*0*11	Set audio level 11	
5*0*12	Set audio level 12	
5*0*13	Set audio level 13	
5*0*14	Set audio level 14	
5*0*15	Set audio level 15	
6*2*2*0*0	Set Audio Path. Int Mic, IntSpk, RX unmute, TX unmute	
6*4*6*0*0	Set Audio Path. Boom Mic, Boom Spk, RX unmute, TX unmute	
10*0*3	Set band GSM 900	
10*0*4	Set band DCS 1800	
10*0*5		
10*0*6	Set dual band GSM 900 / 1800	
10*1*0	Read band	3= GSM 4= DCS 5= PCS 6 =GSM/DCS
18*0	Initialize non-volatile memory (Master Reset)	
18*1	Initialize non-volatile memory (Master Clear)	
55*2*001	Test Display. All pixels ON	
55*2*000	Test Display. All pixels OFF	
55*2*002	Test Display. Checkerboard pattern A	
55*2*003	Test Display. Checkerboard pattern B	
55*2*004	Test Display. Border pixels ON	
*#06#	IMEI Check	No Test Mode Required
Phone Set up --> Phone Status --> Other Information	Flex Version / Technology / S-W Version / Readiness Status	No Test Mode Required

## Programming: Software Upgrade and Flexing

Contact your local technical support engineer for information about equipment and procedures for flashing and flexing.

## Part Numbers

The following information is provided as a reference for the parts associated with Aura telephones.

### Exploded View Diagram

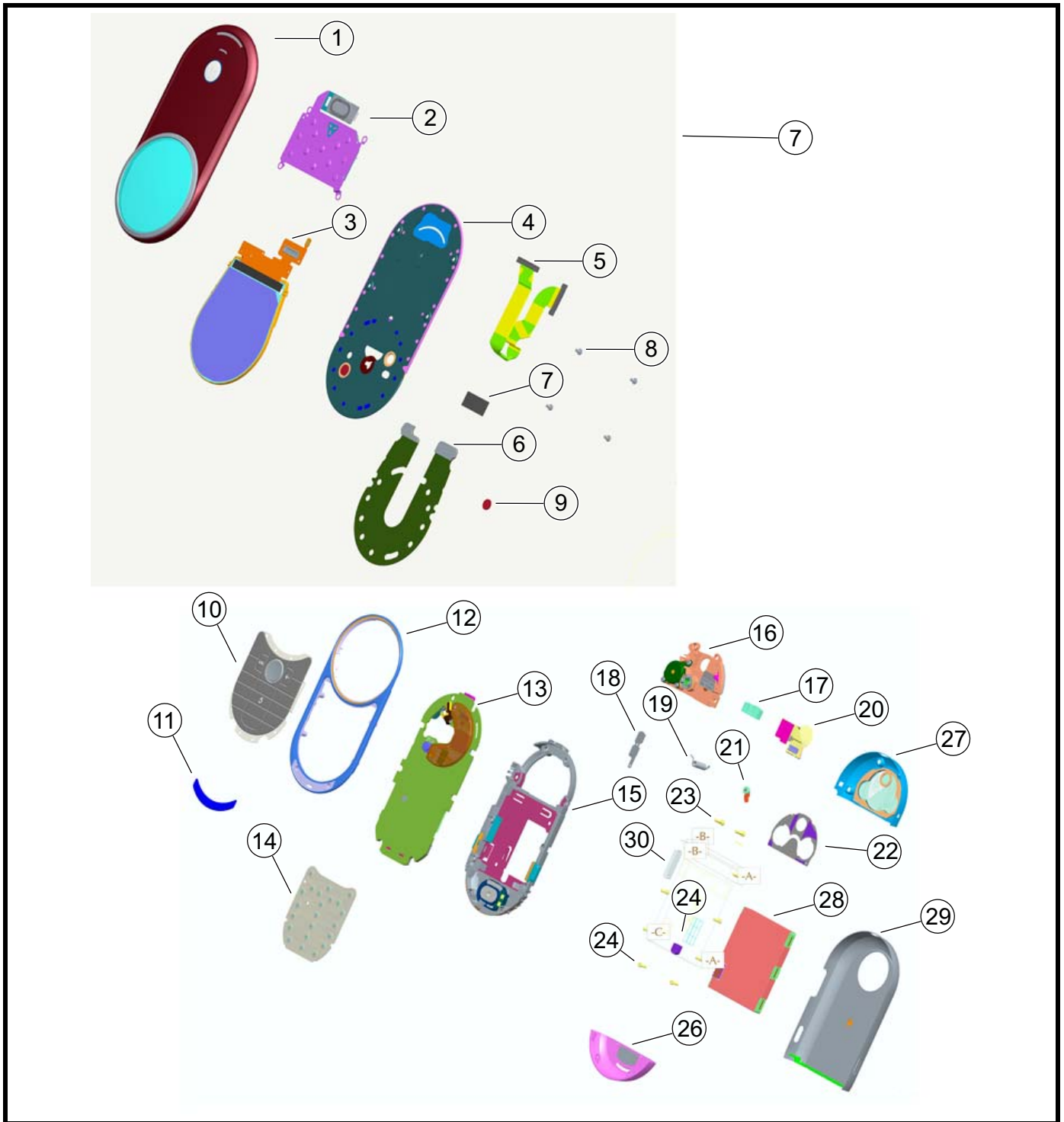

v561583

Figure 111. Exploded View Diagram

## Exploded View Parts List

The following part numbers are provided only for reference. Please contact your local Motorola parts organization for current part number information.

**Table 5. Parts List**

Item	Motorola Part Number	Description
1	01000024002	ASSEMBLY, BLADE WITH LENS
2	01000091001	ASSEMBLY, BOARD, BLADE SUPPORT
3	7271740F01	DISPLAY, LCD, ROUND, 1.5IN, TFT TM, 480X480, ASSEMBLY, TOP LEVEL COLOR MAIN
4	15000141002	HOUSING, BLADE PLATE & BEARING WITH MAGNET
5	01000019001	WIRING HARNESS, ASSEMBLY, 30-LINE MICRO-COAX
6	11000095001	OVERLAY, DISPLAY, DISPLAY SPACER
7	32000952001	GASKET, PORON, BLADE CONNECTORS
8	03000107001	SCREW, MACHINE, M1.4X.3, 1.9MM, PAN, STAINLESS STEEL, FLAT TOP
9	59000029001	MAGNET, HALL EFFECT
10	38000048002	KEYPAD, ASSY
11	75000140002	BUMPER, XCVR RIDING SURFACE DECO WITH ADHESIVE
12	15000045002	HOUSING, FRONT, XCVR DECORATED
13	SLG5561JD	ASSEMBLY, PWA, TRANSCEIVER, P3C
14	40000021001	KEYPAD SWITCH, MYLAR AND DOMES, 22, SPST, ARRAY
15	15000054002	HOUSING ASSEMBLY, REAR, XCVR
16	01000006001	ASSEMBLY, MODULE, DRIVE
16	55000138001	WHEEL, DETENT SLIDER + STAINLESS STEEL BEARING
17	13000055002	BEZEL, XCVR HINGE COVER DECORATIVE
18	01000092001	ASSEMBLY, FLEX VOLUME KEY
19	41000128001	SPRING, TORSION
20	01000056001	ASSEMBLY, MODULE, CAMERA FLEX
22	32000081001	GASKET, POLYPHONIC REAR SIDE
23	03000134001	SCREW, MACHINE, M1.6X.35, 5.5MM, STAR, STEEL, TOP CAP
24	03001185001	SCREW, M1.6X.64, 4.4MM, STAR, CARBON STEEL, PLASTIC THREAD FORMING, DELTA-PT 16 X 0.64
25	05000689001	GROMMET, RF DECORATED
26	15001913002	HOUSING, ASSY, CAP, ANT
27	15000066002	HOUSING ASSEMBLY, CARBON TOP CAP, LOOK
28		Battery
29		Battery Door
30	38000078002	BUTTON, VOLUME, KEY DECORATED
N/A	11000906002	TAPE, BLADE PLATE INSULATOR
N/A	35000031001	SCREEN, EARPIECE TERTIARY PORT MESH
N/A	05000080001	GROMMET, SILICONE, USB WATER SEAL
N/A	11000906001	TAPE, SIDE-KEY ZIF ASSEMBLY
N/A	11007253001	PROTECTIVE LINER, W/ ADHESIVE, PSA
N/A	5471536C01	LABEL, ADHESIVE, WATER DETECT, 3MM X .26



---

The "Replacement Parts Service Division (RPSD)" section on page 8 provides information about ordering replacement parts.



*There is a danger of explosion if the Lithium Ion battery pack is replaced incorrectly. Replace only with the same type of battery or equivalent as recommended by the battery manufacturer. Dispose of used batteries according to the manufacturer's instructions.*



---

# INDEX

## A

- About 6
- active line indicator 16
- airplane mode 16
- alert settings 16
- alert style indicator 16
- antenna cover
  - removing 21

## B

- battery
  - function 16
  - removing 18
- battery housing
  - removing 18
- battery indicator 16
- blade assembly, removing and replacing 36
- Blade Disassembly 31
- Blade Disassembly Without Disassembly of the Transceiver 34
- Bluetooth indicator 15

## C

- call forward indicator 16
- Canadian Interference-Causing Equipment regulations 5
- changes
  - product 5
- commands, manual test mode 93
- conventions 7
- copyrights
  - computer software 6

## D

- disassembly 18

## E

- EDGE indicator 15
- exploded view diagram 95
- exploded view parts list 96

## F

- FCC rules 5
- features
  - Wireless Access Protocol (WAP) 12

## G

- GPRS indicator 15

## I

- identification 91
  - international mobile station equipment identity 92
  - mechanical serial number 91
  - product 5
- IM indicator 16
- IMEI 92
- in-call indicator 16
- Introduction 5

## L

- line 1 and line 2 16
- location indicator 16
- Low Battery message 16

## M

- manual test mode 93
- menu
  - structure diagram 16
- message indicator 16
- missed event indicator 16
- MSN 91

## N

- names
  - product 5

## O

- operation
  - controls, indicators, and I/O 13
  - operation, general 13
  - overview, product 11

## P

- parts 94
  - exploded view diagram 95
  - exploded view parts list 96
- product
  - changes 5
  - identification 5
  - names 5
  - product overview
    - features 11
  - profiles 16

---

**R**

regulatory agency compliance 5

removing

- antenna cover 21
- battery 16, 18
- battery housing 18
- blade assembly 36
- SIM 19

replacement parts

- contact information 7

replacing

- antenna cover 21
- battery 18
- blade assembly 36
- SIM 19

**S**

Scope 6

serial number

- mechanical 91

service manual

- about 6
- revisions 7

service policy 7

- customer support 7
- out of box failure 7
- product support 7

service procedure

- ordering replacement parts 7

shut down

- upon battery removal 16

signal strength indicator 15

SIM card 91

- personality transfer 91
- replacing 20

SIM, removing and replacing 19

specifications 9

support

- customer 7
- product 7

**T**

tools and test equipment 17

Transceiver Assembly Procedure 58

troubleshooting 93

- manual test mode 93
- manual test mode commands 93

**U**

user interface diagrams 16

**W**

warranty service 7

wireless access protocol (WAP) 12