

VERTEX SYSTEM 4.0

01/22/16
04-S28-2014

REVISIONS				
ZONE	LTR	DESCRIPTION	DATE	APPROVED

D

D

C

C

B

B

A

A

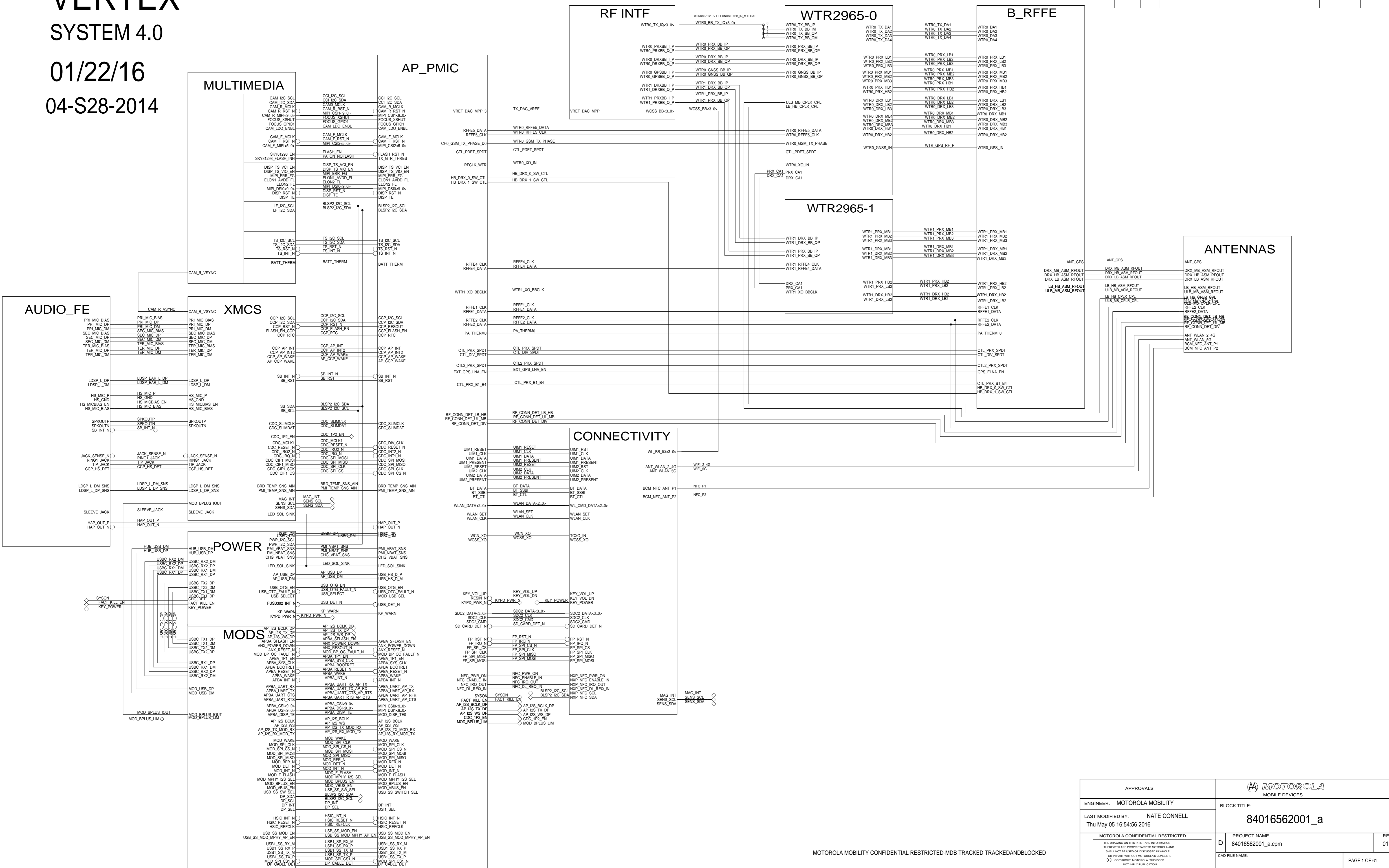

APPROVALS		MOTOROLA MOBILE DEVICES	
ENGINEER:	MOTOROLA MOBILITY	BLOCK TITLE:	84016562001_a
LAST MODIFIED BY:	NATE CONNELL	PROJECT NAME:	84016562001_a.cpm
	Thu May 05 16:54:56 2016	REV	01
MOTOROLA CONFIDENTIAL RESTRICTED		CAD FILE NAME:	
<small>THIS DRAWING IS THE PROPERTY OF MOTOROLA AND SHALL NOT BE USED OR DISCLOSED IN WHOLE OR IN PART WITHOUT MOTOROLA'S CONSENT. © COPYRIGHT, MOTOROLA, THIS DOES NOT APPLY TO PUBLICATIONS.</small>		PAGE 1 OF 61	

MOTOROLA MOBILITY CONFIDENTIAL RESTRICTED-MDB TRACKED TRACKEDANDBLOCKED

VERTEX ME/SHIELDS

JANUS REFERENCE DESIGNATOR RANGES BY BLOCK

- 000 - 499: ANTENNA
- 500 - 599: USER INPUT
- 600 - 799: POWER
- 1000-2999: MSM8852 + PM8952
- 3000-3049, 3100-3149: WTR2955
- 3050-3099, 3150-3199: CA_WTR2955
- 3200-3999: MSM8952 + PM8952
- 4000-4499: CONNECTIVITY
- 4500-4999: AUDIO FE
- 5000-5499: DISPLAY
- 5500-5999: CAMERA
- 6000-6999: XMCS
- 7000-8999: RFFE

PLACE M100 AND M105 NEAR DIVERSITY ANTENNA KEEP OUT

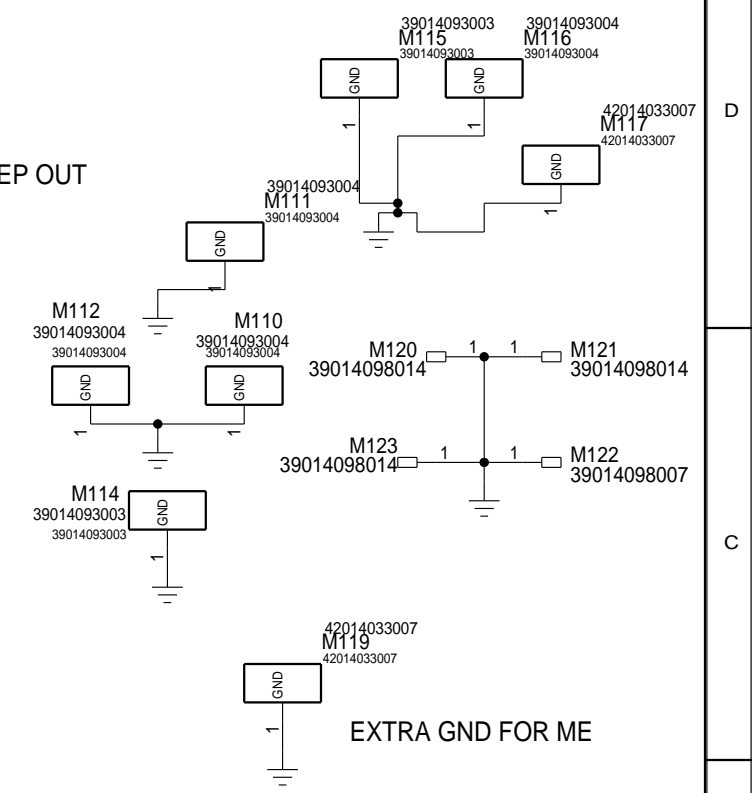
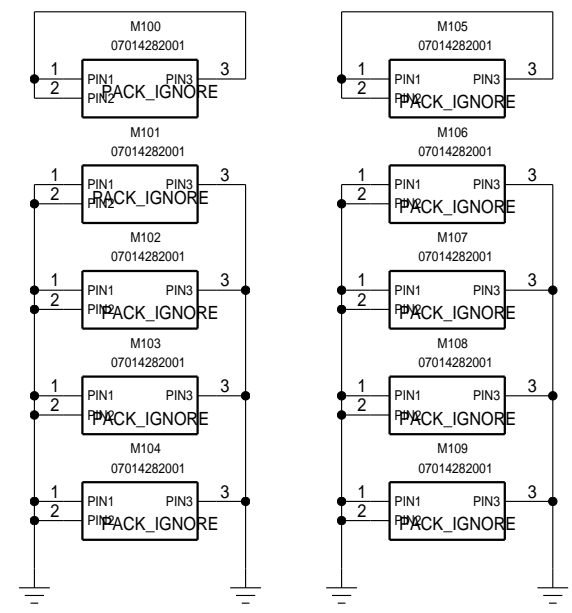

UNIVERSAL GROUND CONTACTS

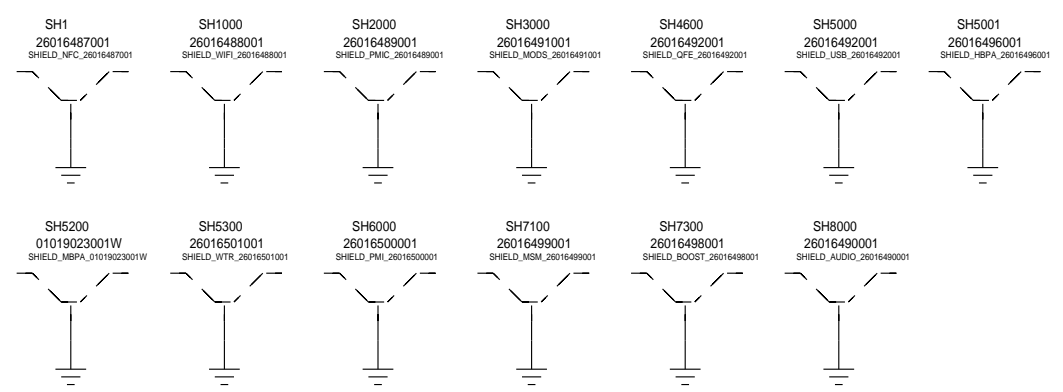
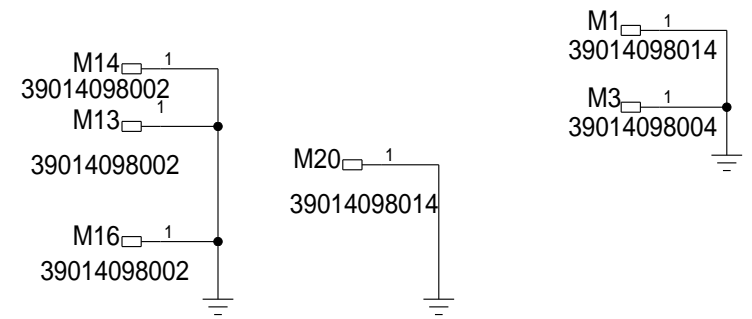

MOTOROLA MOBILITY CONFIDENTIAL RESTRICTED-MDB TRACKED TRACKEDANDBLOCKED

APPROVALS	 MOTOROLA MOBILE DEVICES	
ENGINEER:	BLOCK TITLE:	
LAST MODIFIED BY:	84016562001_a	
MOTOROLA CONFIDENTIAL RESTRICTED	PROJECT NAME	REV
THE DRAWING ON THIS PRINT AND INFORMATION THEREWITH ARE PROPRIETARY TO MOTOROLA AND SHALL NOT BE USED OR DISCUSSED IN WHOLE OR IN PART WITHOUT MOTOROLA'S CONSENT. © COPYRIGHT, MOTOROLA. THIS DOES NOT IMPLY PUBLICATION	B 84016562001_a.cpm	01
	CAD FILE NAME:	PAGE 2 OF 61

ANT: ANTENNA
REF:100-130

REVISIONS				
ZONE	LTR	DESCRIPTION	DATE	APPR.

MAIN ANTENNA

DEVICE LOCATION - BOTTOM RIGHT
(GSM/UTMS/LTE)

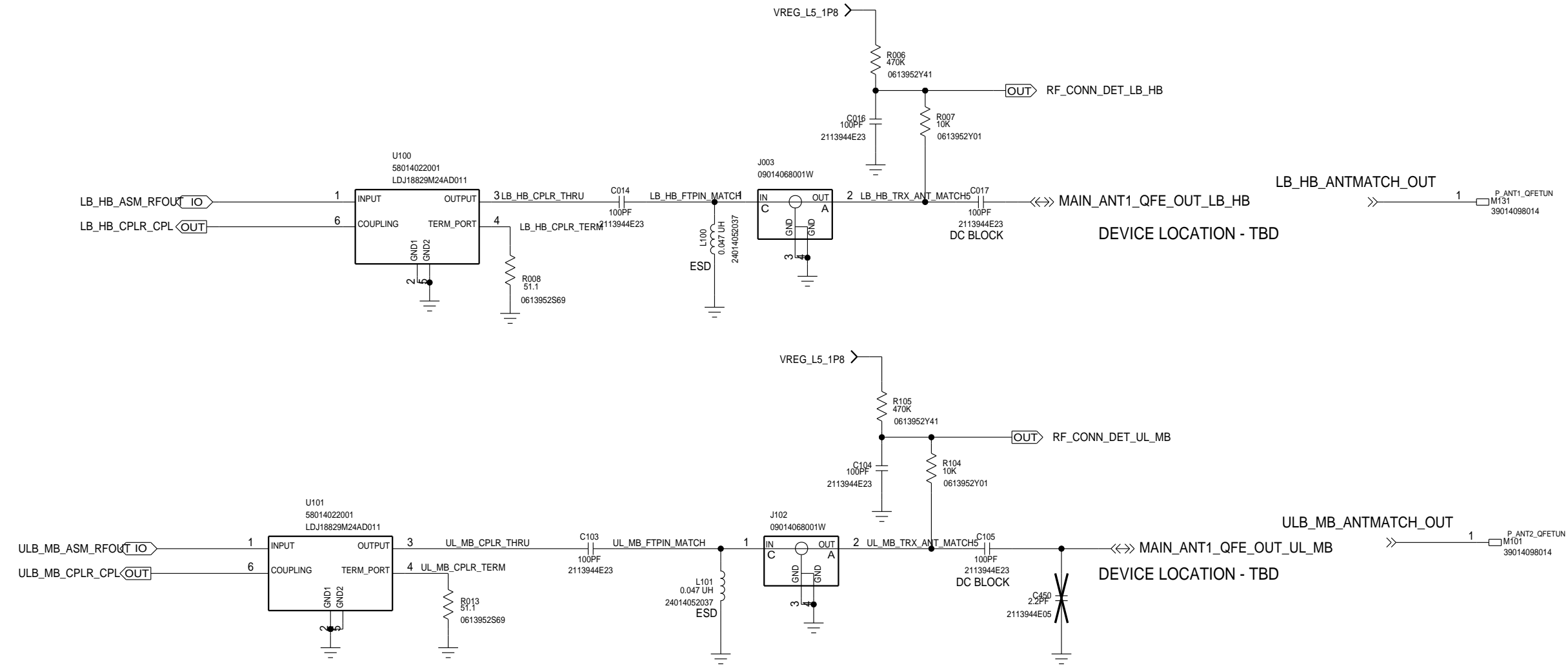

DRX LOW / HIGH BAND ANTENNA

DEVICE LOCATION - TOP LEFT
(GSM/UTMS/LTE)

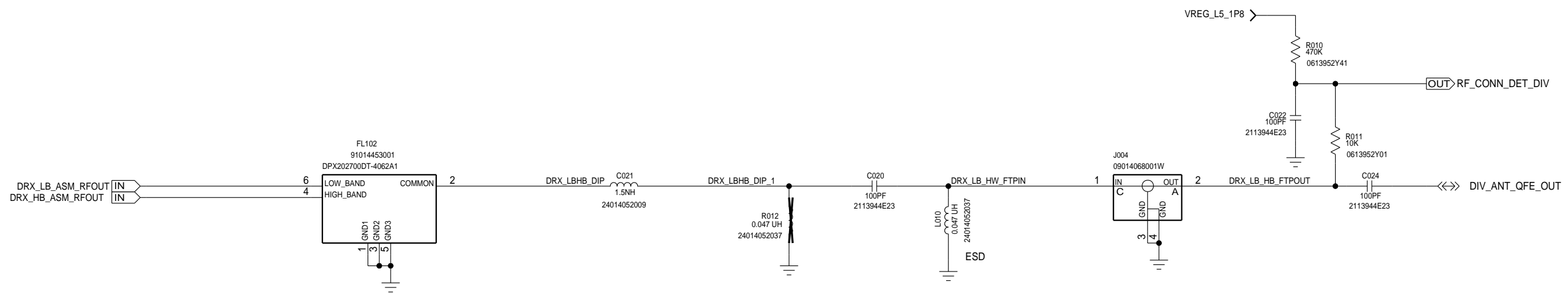

DRX MID BAND/GPS/BT/WLAN ANTENNA

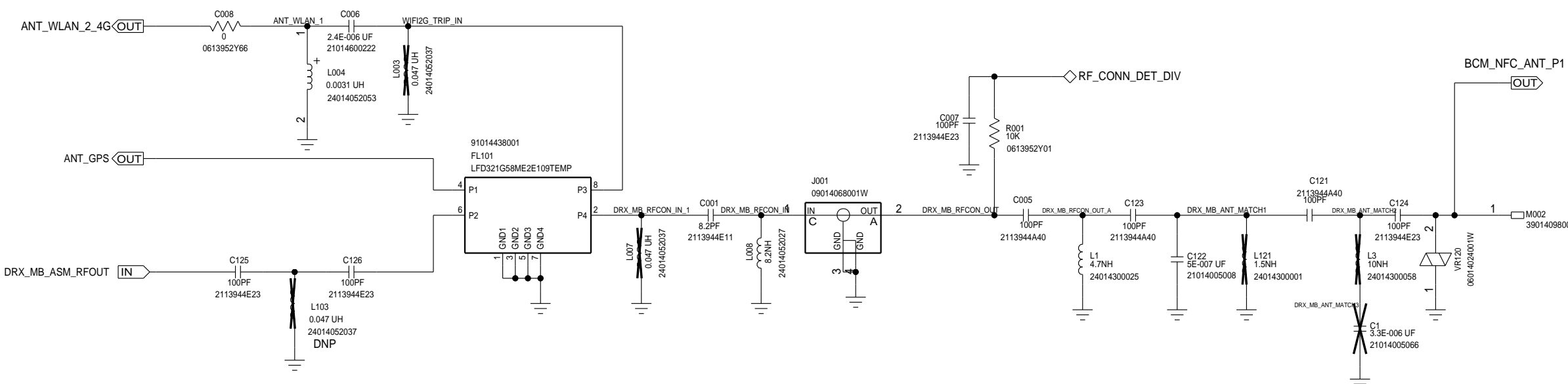

WIFI 5G ANTENNA

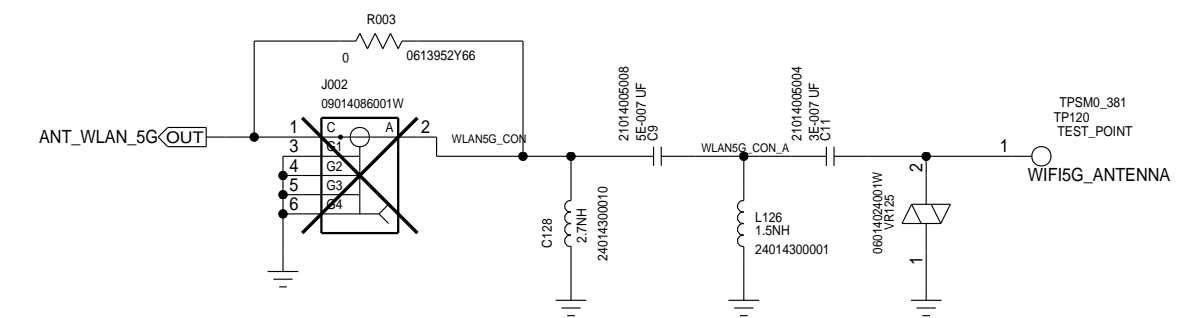

APPROVALS		 MOBILE DEVICES	
ENGINEER: ADDISON ANTENNA TEAM		BLOCK TITLE:	
LAST MODIFIED BY: LEO		antennas	
Fri Jun 17 10:55:11 2016		PROJECT NAME	
MOTOROLA CONFIDENTIAL RESTRICTED		C	84016562001_a.cpm
<small>THE DRAWING ON THIS PRINT AND INFORMATION THEREWITH ARE PROPRIETARY TO MOTOROLA AND SHALL NOT BE USED OR DISCUSSED IN WHOLE OR IN PART WITHOUT MOTOROLA'S CONSENT. © COPYRIGHT, MOTOROLA, THIS DOES NOT IMPLY PUBLICATION</small>		CAD FILE NAME:	
		REV 01	
		PAGE 3 of 61	

ANT: QCOM TUNERS

REFDES: 400-499

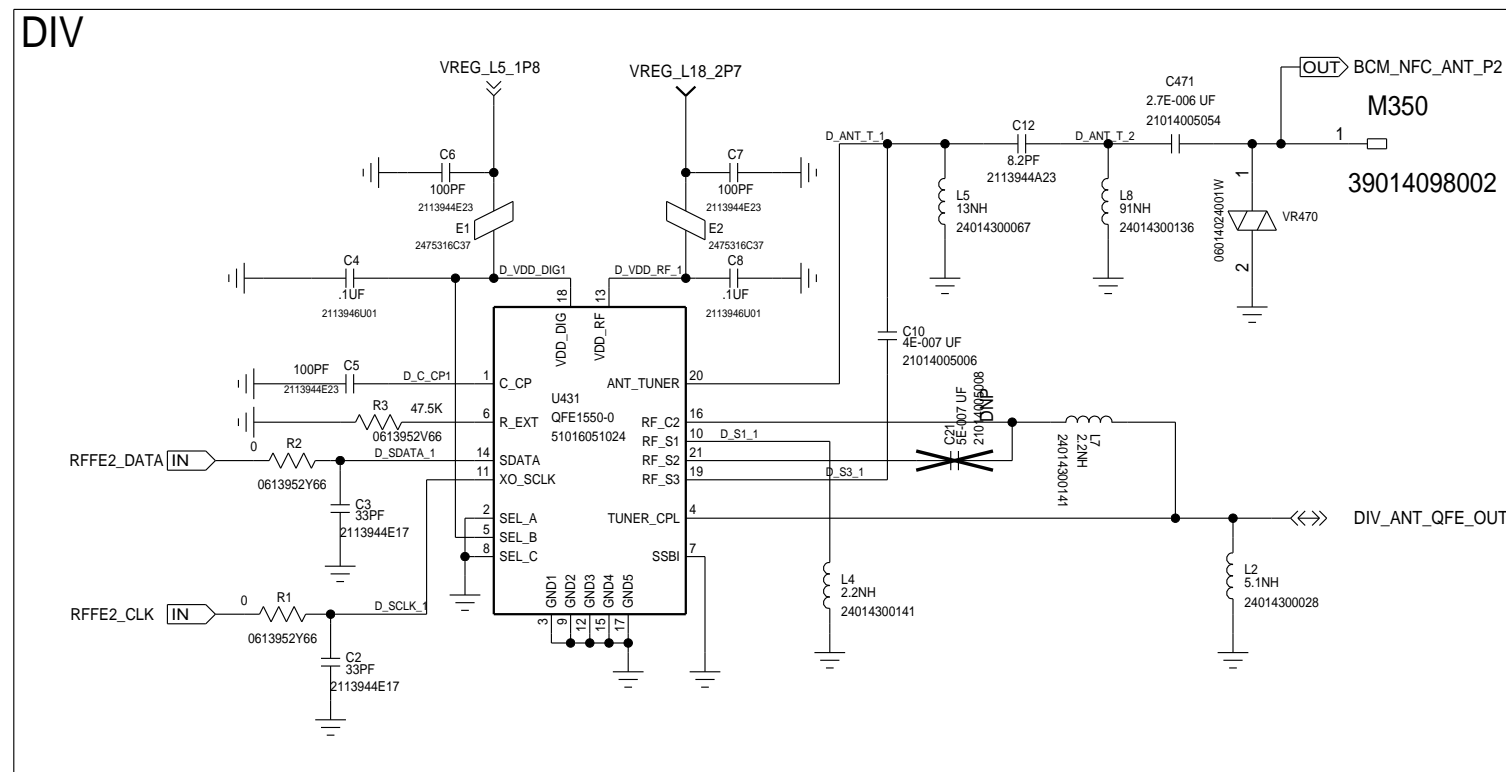
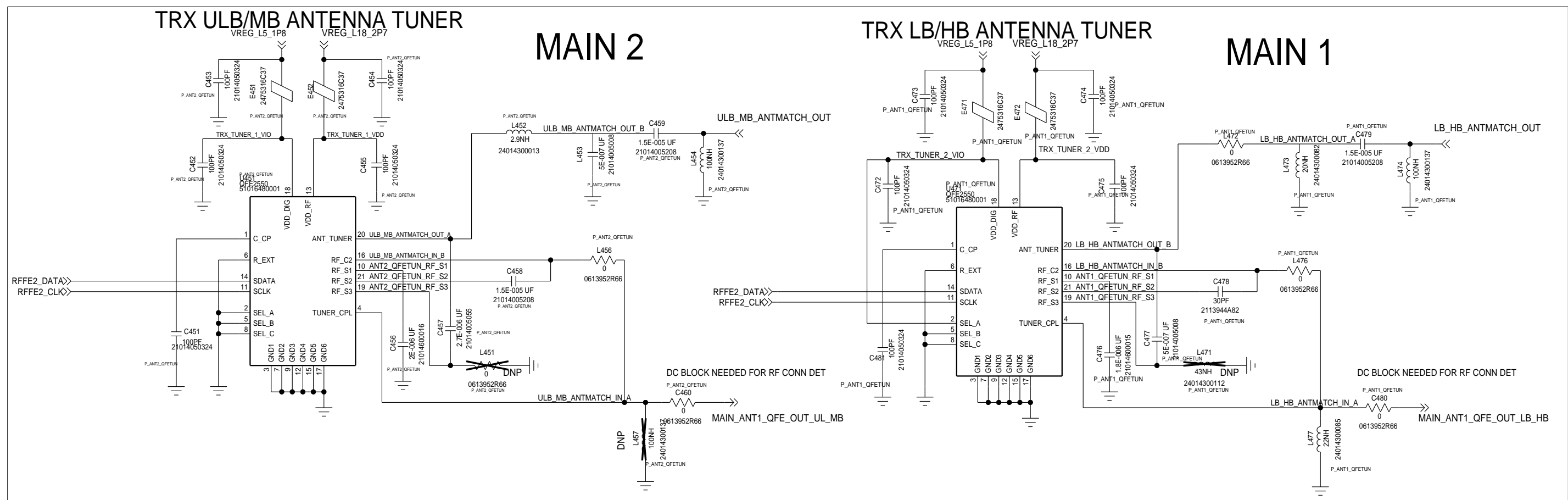

APPROVALS		MOTOROLA MOBILE DEVICES	
ENGINEER: ADDISON ANTENNA TEAM		BLOCK TITLE:	
LAST MODIFIED BY: LEO Thu May 05 16:54:55 2016		antennas	
MOTOROLA CONFIDENTIAL RESTRICTED <small>THE DRAWING ON THIS PRINT AND INFORMATION THEREWITH ARE PROPRIETARY TO MOTOROLA AND SHALL NOT BE USED OR DISCUSSED IN WHOLE OR IN PART WITHOUT MOTOROLA'S CONSENT. © COPYRIGHT, MOTOROLA. THIS DOES NOT IMPLY PUBLICATION</small>		PROJECT NAME	REV
		B 84016562001_a.cpm	01
CAD FILE NAME:		PAGE 4 OF 61	

AFE: MICS

REF: 5700-5799

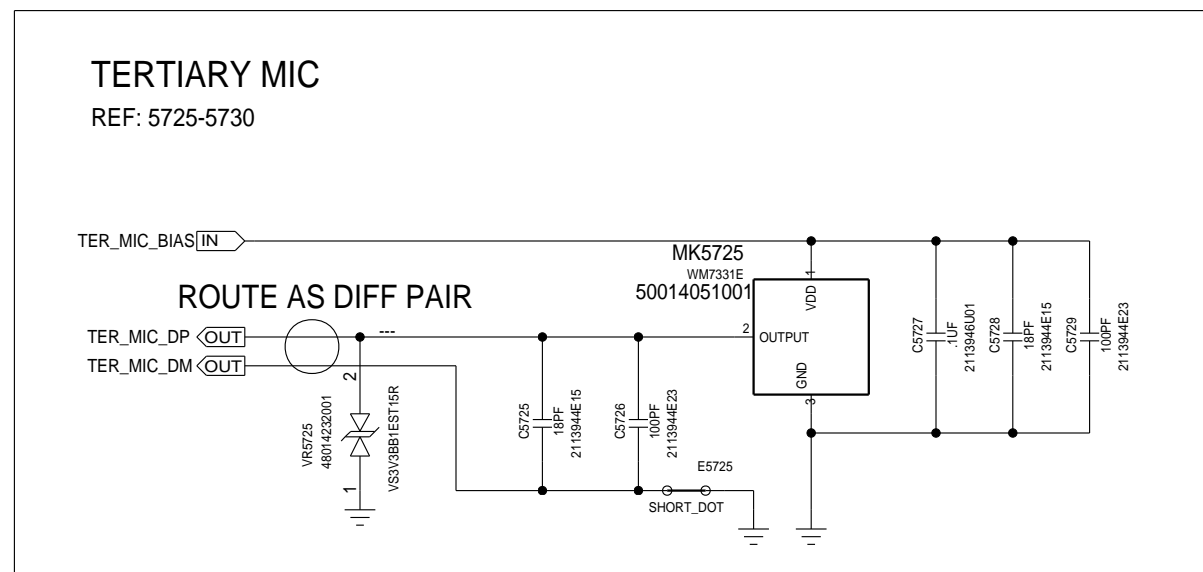
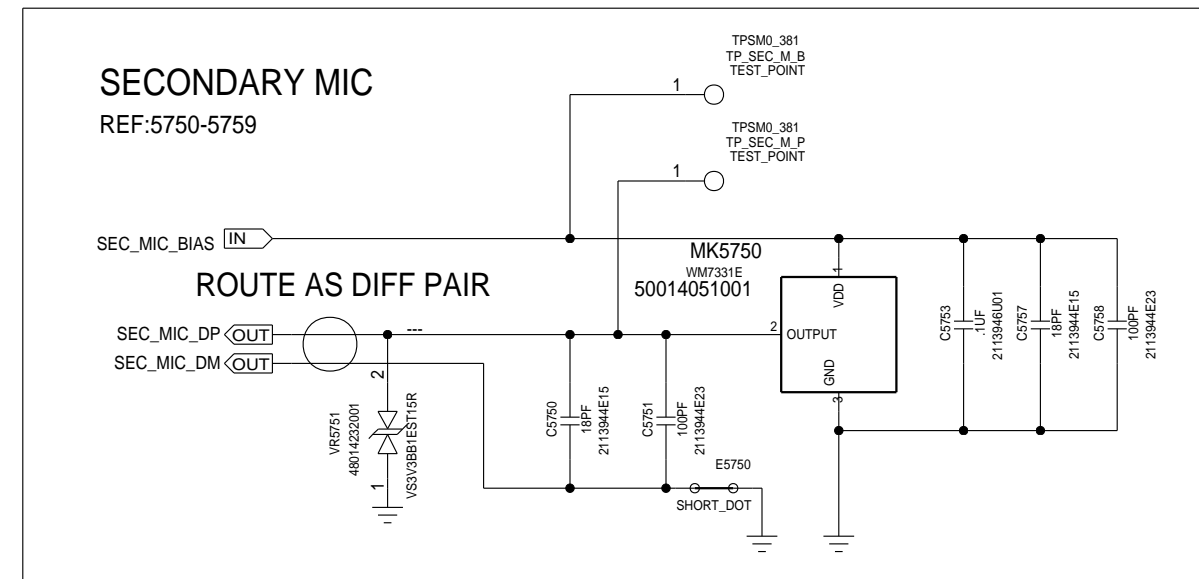
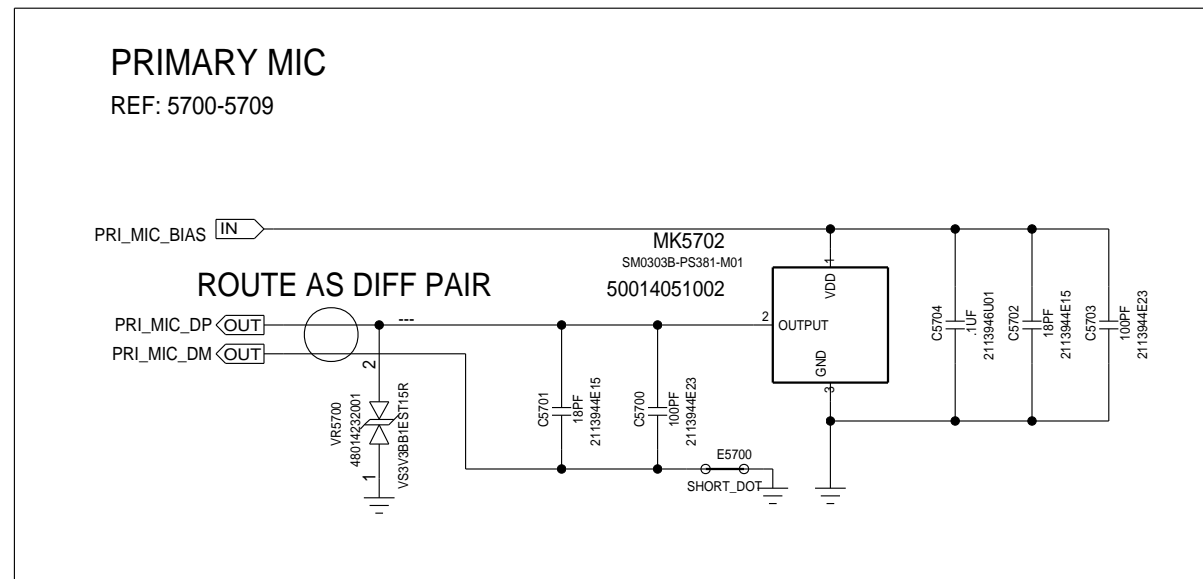

APPROVALS		MOTOROLA MOBILE DEVICES	
ENGINEER: DENNIS BUDNICK		BLOCK TITLE:	
LAST MODIFIED BY: NATE CONNELL Mon Jun 06 20:52:01 2016		audio_fe	
MOTOROLA CONFIDENTIAL RESTRICTED <small>THE DRAWING ON THIS PRINT AND INFORMATION THEREWITH ARE PROPRIETARY TO MOTOROLA AND SHALL NOT BE USED OR DISCUSSED IN WHOLE OR IN PART WITHOUT MOTOROLA'S CONSENT. © COPYRIGHT, MOTOROLA. THIS DOES NOT IMPLY PUBLICATION</small>		PROJECT NAME	REV
		B 84016562001_a.cpm	01
CAD FILE NAME:		PAGE 5 OF 61	

AFE: SPEAKERS

LOUDSPEAKER/EAR PIECE

REF:5790-5799

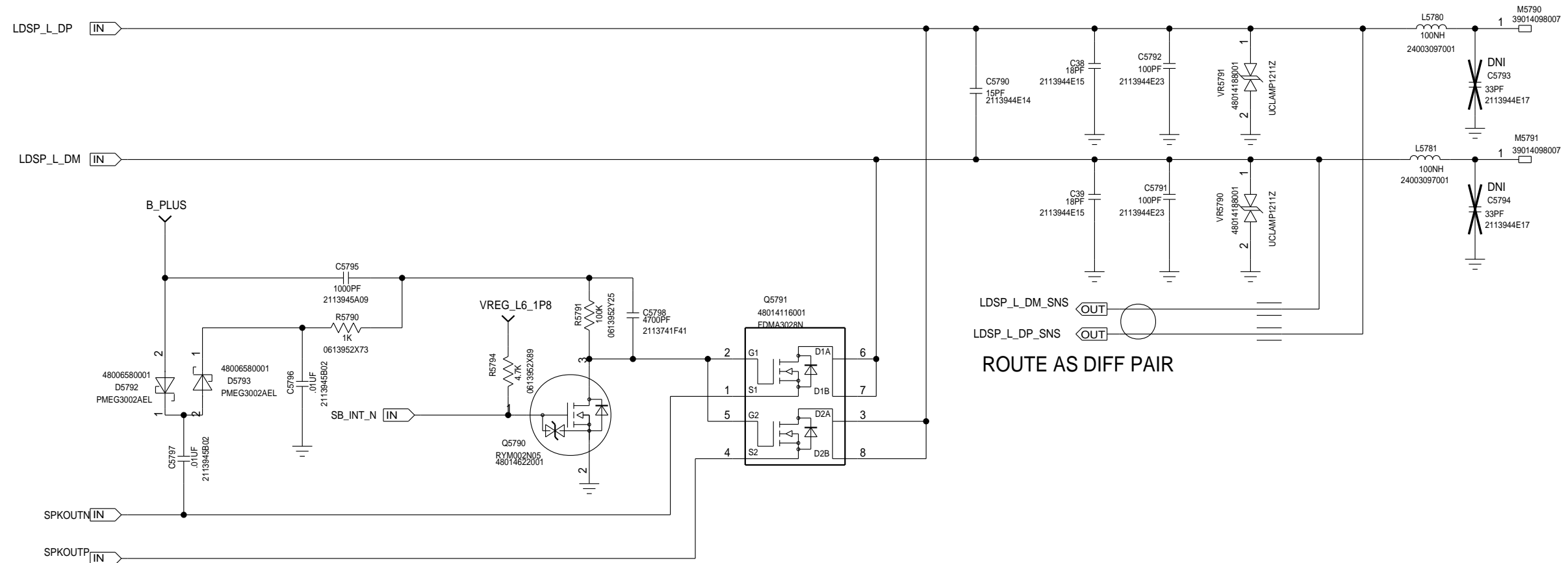

LINEAR VIBRATOR

REF 5100-5119

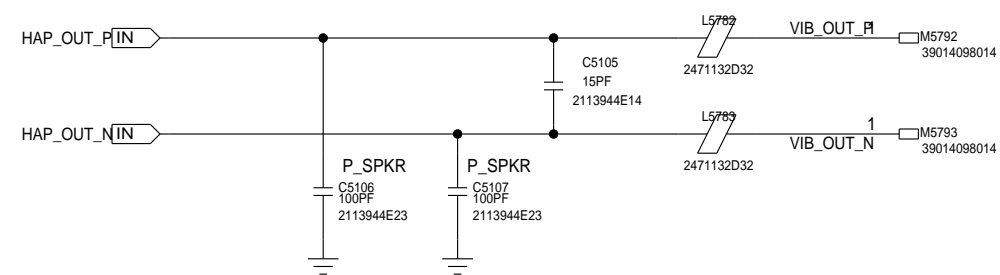

APPROVALS		MOTOROLA MOBILE DEVICES	
ENGINEER: DENNIS BUDNICK		BLOCK TITLE: audio_fe	
LAST MODIFIED BY: TIM MILLER Fri Jun 17 10:55:14 2016		PROJECT NAME B 84016562001_a.cpm	REV 01
MOTOROLA CONFIDENTIAL RESTRICTED <small>THE DRAWING ON THIS PRINT AND INFORMATION THEREWITH ARE PROPRIETARY TO MOTOROLA AND SHALL NOT BE USED OR DISCUSSED IN WHOLE OR IN PART WITHOUT MOTOROLA'S CONSENT. © COPYRIGHT, MOTOROLA. THIS DOES NOT IMPLY PUBLICATION</small>		CAD FILE NAME:	
		PAGE 6 OF 61	

AFE: 3.5MM HEADSET

3.5MM HSJ
REF:4900-4949

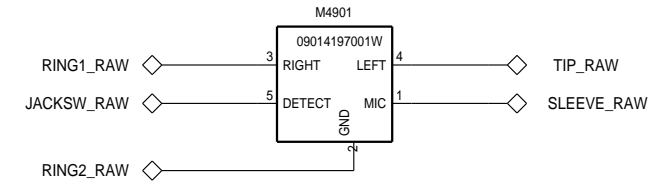
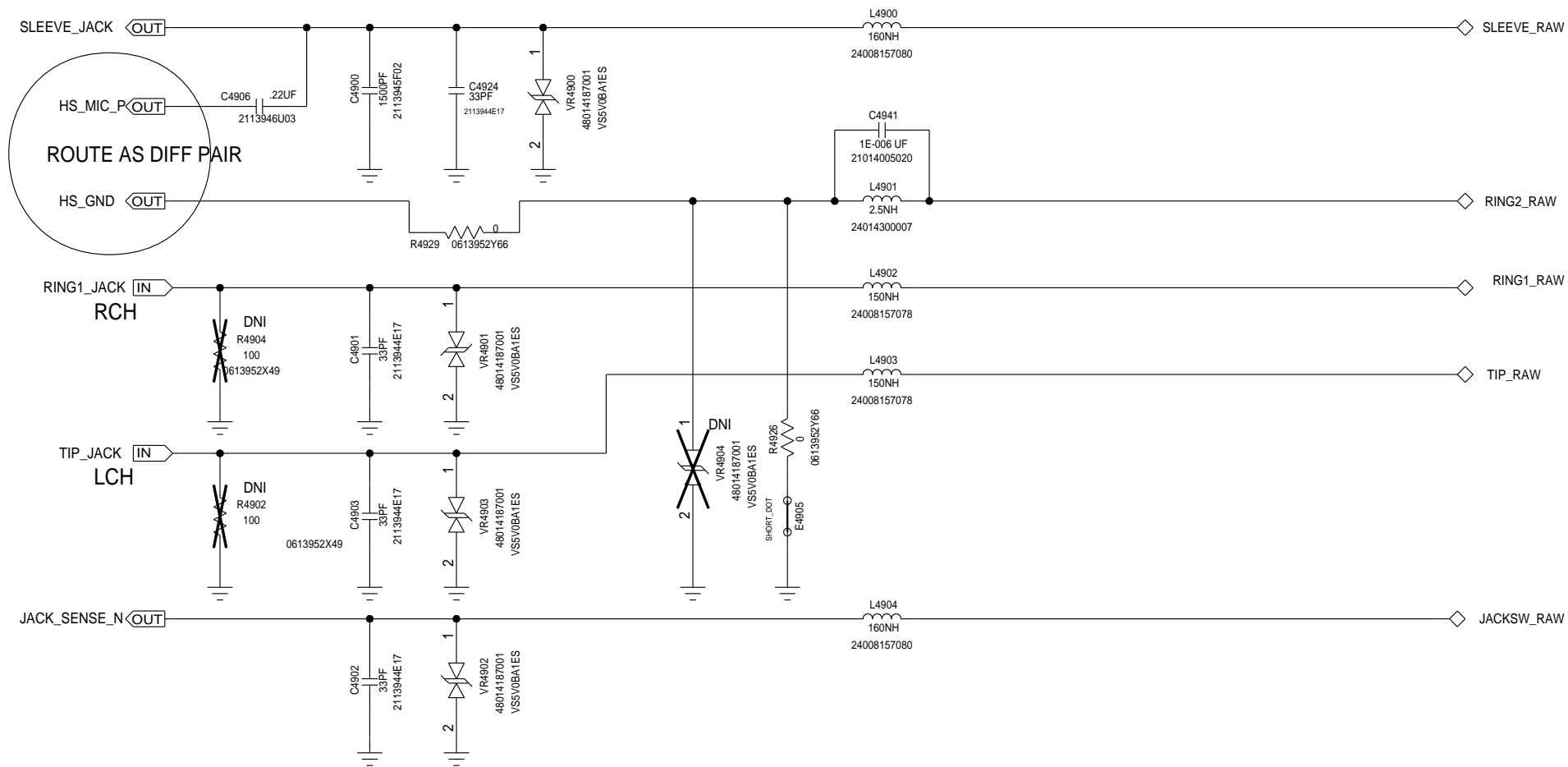

SENSOR HUB HEADSET DETECTION CIRCUIT

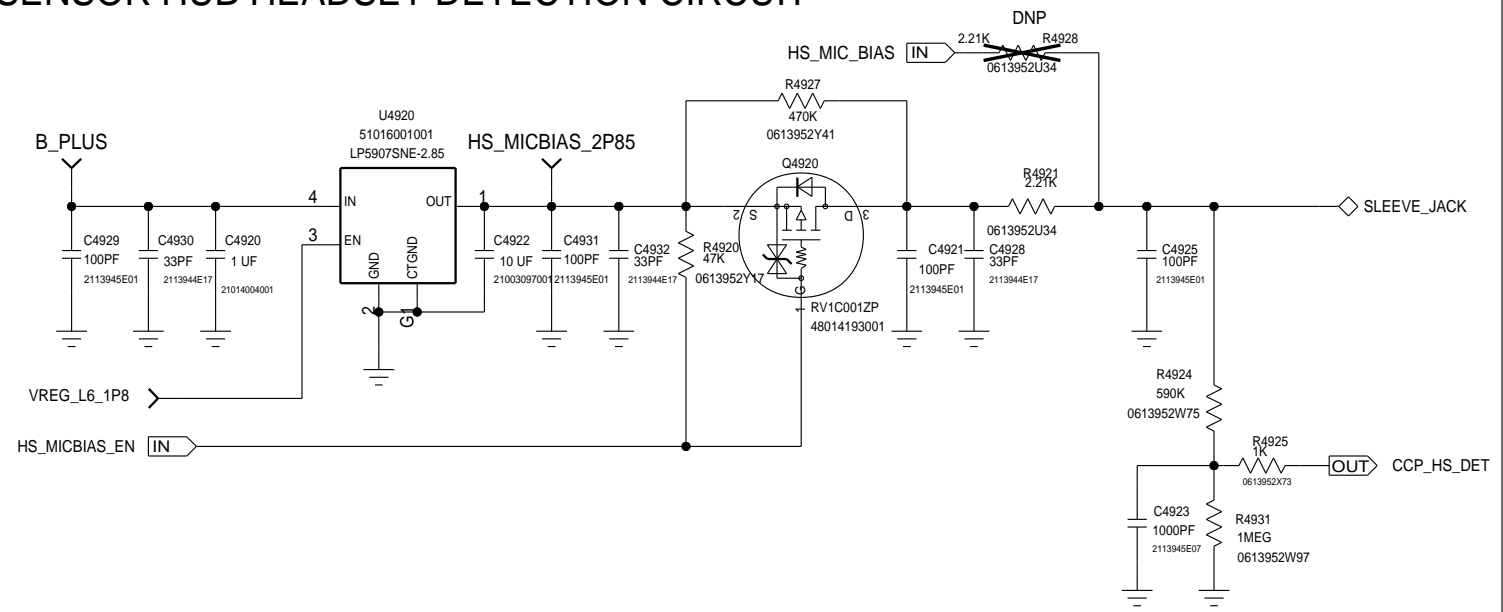

APPROVALS		MOTOROLA MOBILE DEVICES	
ENGINEER: MMI		BLOCK TITLE: audio_fe	
LAST MODIFIED BY: MMI Tue May 24 15:06:44 2016		PROJECT NAME B 84016562001_a.cpm	REV 01
MOTOROLA CONFIDENTIAL RESTRICTED <small>THE DRAWING ON THIS PRINT AND INFORMATION THEREWITH ARE PROPRIETARY TO MOTOROLA AND SHALL NOT BE USED OR DISCUSSED IN WHOLE OR IN PART WITHOUT MOTOROLA'S CONSENT. © COPYRIGHT, MOTOROLA. THIS DOES NOT IMPLY PUBLICATION</small>		CAD FILE NAME: PAGE 7 OF 61	

PWR: USB-C

REF:5000 - 5219

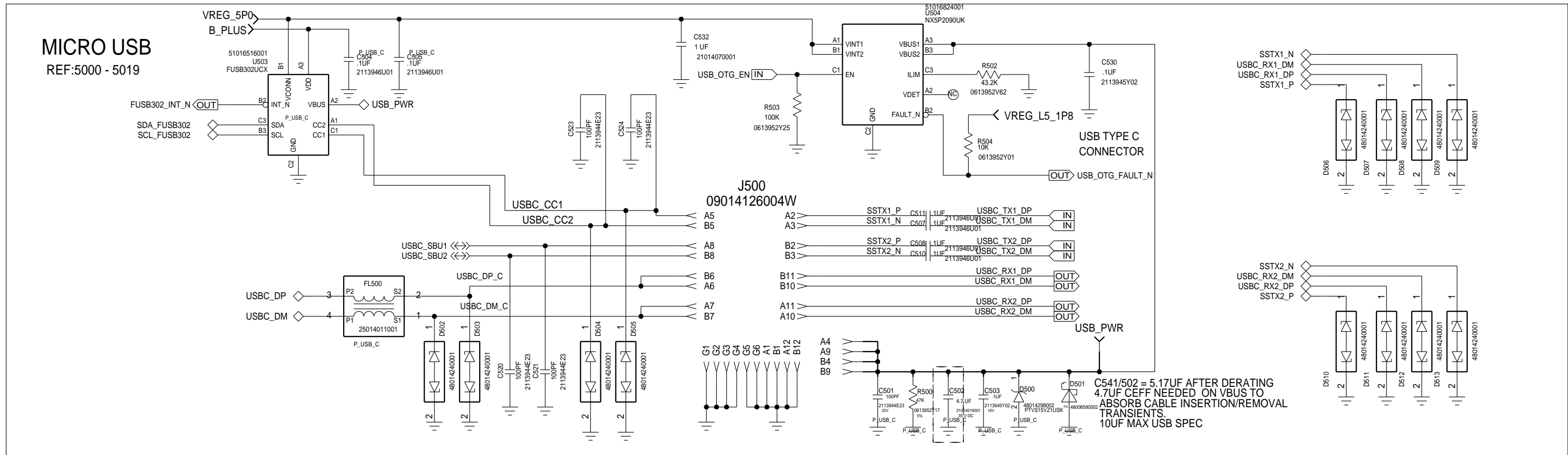

MICRO USB

REF:5000 - 5019

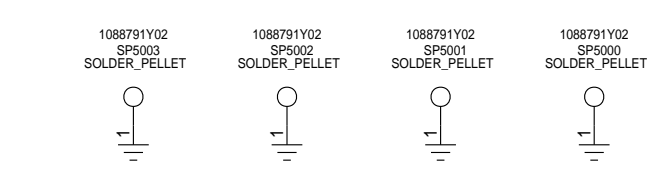
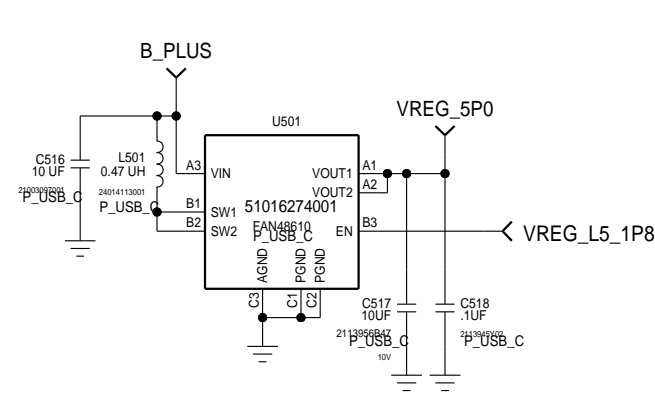
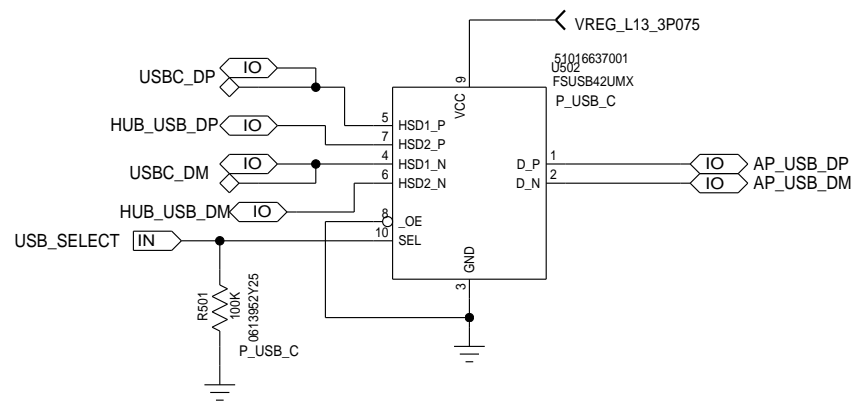
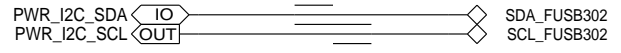
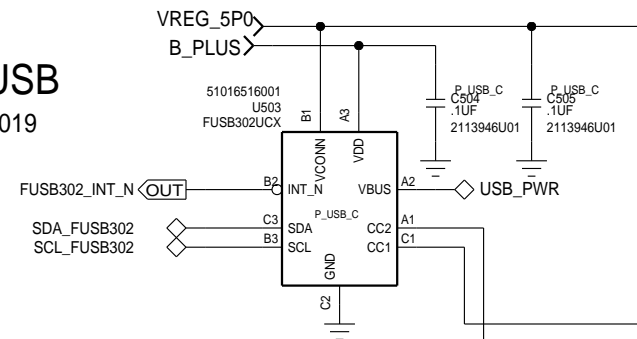

APPROVALS		MOTOROLA MOBILE DEVICES	
ENGINEER: RICH NG		BLOCK TITLE:	
LAST MODIFIED BY: NATE CONNELL Tue May 31 11:44:37 2016		power	
MOTOROLA CONFIDENTIAL RESTRICTED <small>THE DRAWING ON THIS PRINT AND INFORMATION THEREWITH ARE PROPRIETARY TO MOTOROLA AND SHALL NOT BE USED OR DISCUSSED IN WHOLE OR IN PART WITHOUT MOTOROLA'S CONSENT. © COPYRIGHT, MOTOROLA. THIS DOES NOT IMPLY PUBLICATION</small>		PROJECT NAME	REV
		B 84016562001_a.cpm	01
CAD FILE NAME:		PAGE 8 OF 61	

PWR: LIGHTING

SOL LED

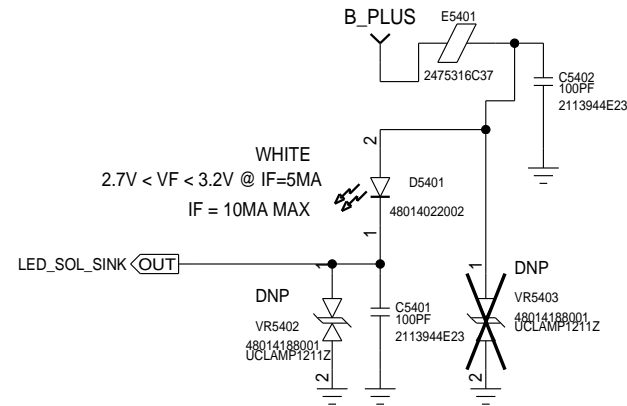

MOTOROLA MOBILITY CONFIDENTIAL RESTRICTED-MDB TRACKED TRACKEDANDBLOCKED

APPROVALS		MOTOROLA MOBILE DEVICES	
ENGINEER:		BLOCK TITLE:	
LAST MODIFIED BY: TIM MILLER Thu May 05 16:54:50 2016		power	
MOTOROLA CONFIDENTIAL RESTRICTED <small>THE DRAWING ON THIS PRINT AND INFORMATION THEREWITH ARE PROPRIETARY TO MOTOROLA AND SHALL NOT BE USED OR DISCUSSED IN WHOLE OR IN PART WITHOUT MOTOROLA'S CONSENT. © COPYRIGHT, MOTOROLA. THIS DOES NOT IMPLY PUBLICATION</small>		PROJECT NAME B 84016562001_a.cpm	REV 01
CAD FILE NAME:			PAGE 9 OF 61

PWR: BATT

REF:5000 - 5219

BATTERY BLOCK

REF:5200 - 5209

PARALLEL BATTERY BLOCK FOR BATTERY ELIMINATOR

KUNG KOW LITE BATTERY DISCONNECT

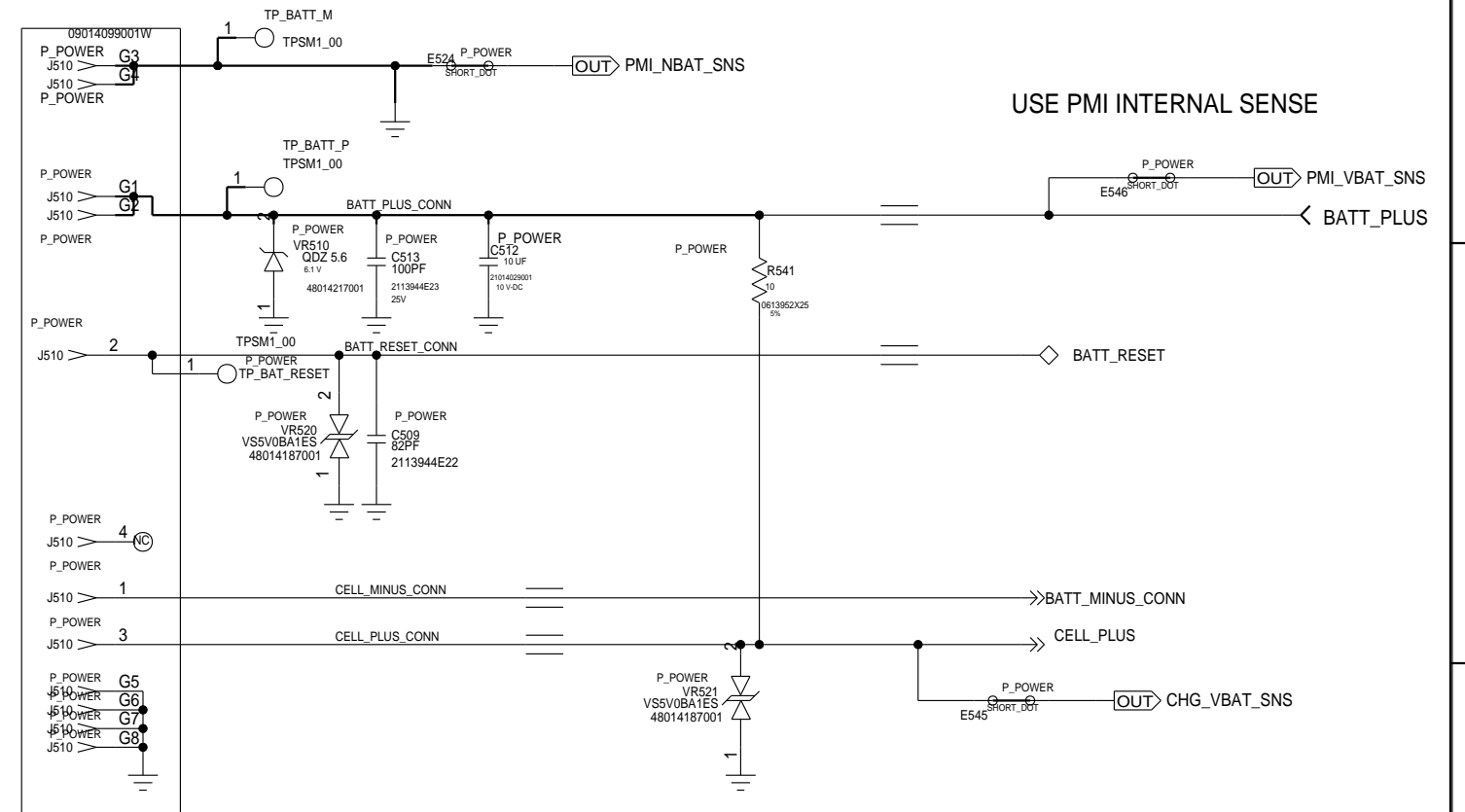
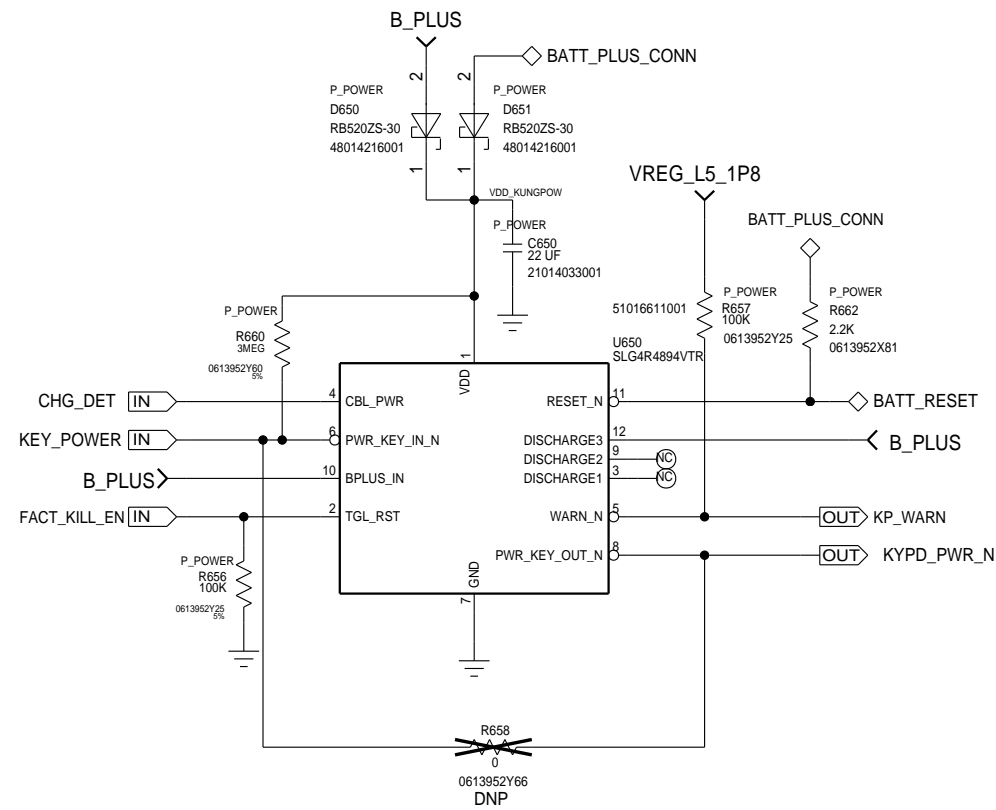

USE PMI INTERNAL SENSE

APPROVALS

ENGINEER: RICH NG

LAST MODIFIED BY: NATE CONNELL
Thu May 05 16:54:51 2016

MOTOROLA CONFIDENTIAL RESTRICTED

THE DRAWING ON THIS PRINT AND INFORMATION
THEREWITH ARE PROPRIETARY TO MOTOROLA AND
SHALL NOT BE USED OR DISCUSSED IN WHOLE
OR IN PART WITHOUT MOTOROLA'S CONSENT.
© COPYRIGHT, MOTOROLA. THIS DOES
NOT IMPLY PUBLICATION



BLOCK TITLE:

power

PROJECT NAME

B 84016562001_a.cpm

CAD FILE NAME:

REV

01

WCN3660B RF/CTRL

REF 4600-4699

NEED TO CHECK PIN47 CONNECTION

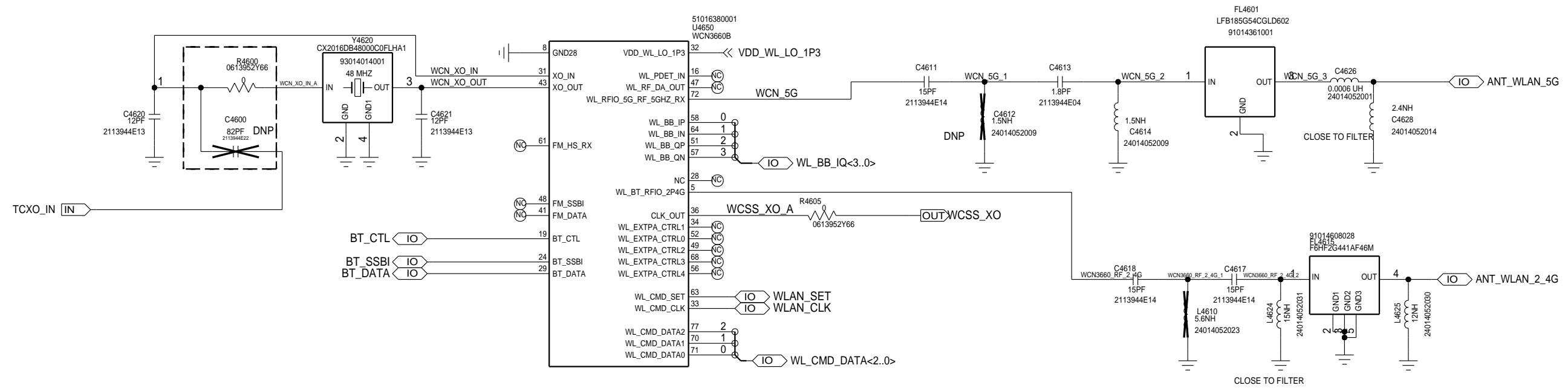

2.4G/5G: DNP-C4600, PLACE-Y4620, C4621, R4600, R4605, ALL 5G RF PATH

BASED ON 80-WL006-44 REV C

APPROVALS		MOTOROLA MOBILE DEVICES	
ENGINEER:		BLOCK TITLE:	
LAST MODIFIED BY: FROEHLING Thu May 05 16:54:45 2016		connectivity	
MOTOROLA CONFIDENTIAL RESTRICTED <small>THE DRAWING ON THIS PRINT AND INFORMATION THEREWITH ARE PROPRIETARY TO MOTOROLA AND SHALL NOT BE USED OR DISCUSSED IN WHOLE OR IN PART WITHOUT MOTOROLA'S CONSENT. © COPYRIGHT, MOTOROLA. THIS DOES NOT IMPLY PUBLICATION</small>		PROJECT NAME	REV
		B 84016562001_a.cpm	01
CAD FILE NAME:		PAGE 11 OF 61	

WCN3660B POWER

REF 4700-4799

BT_FM_WLAN_1P3

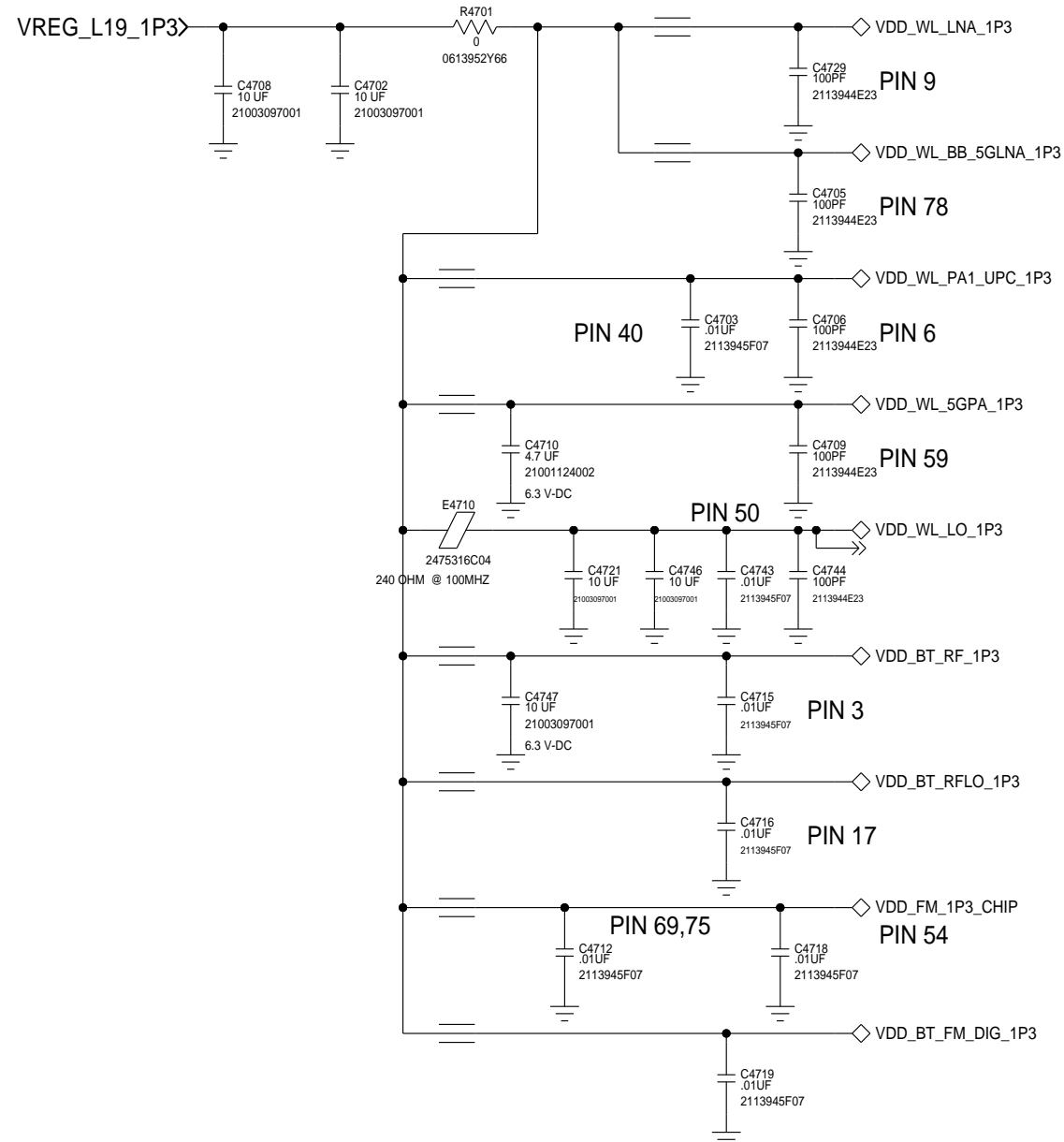

NOTE: RESERVE C4717 AND C4718 FOR 0.01UF BYPASSES

WLBT_3.0V

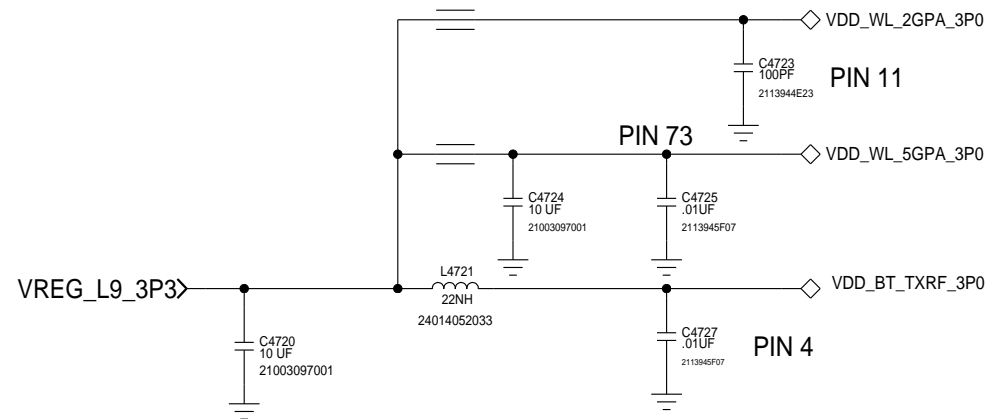

1.8V/2.2V

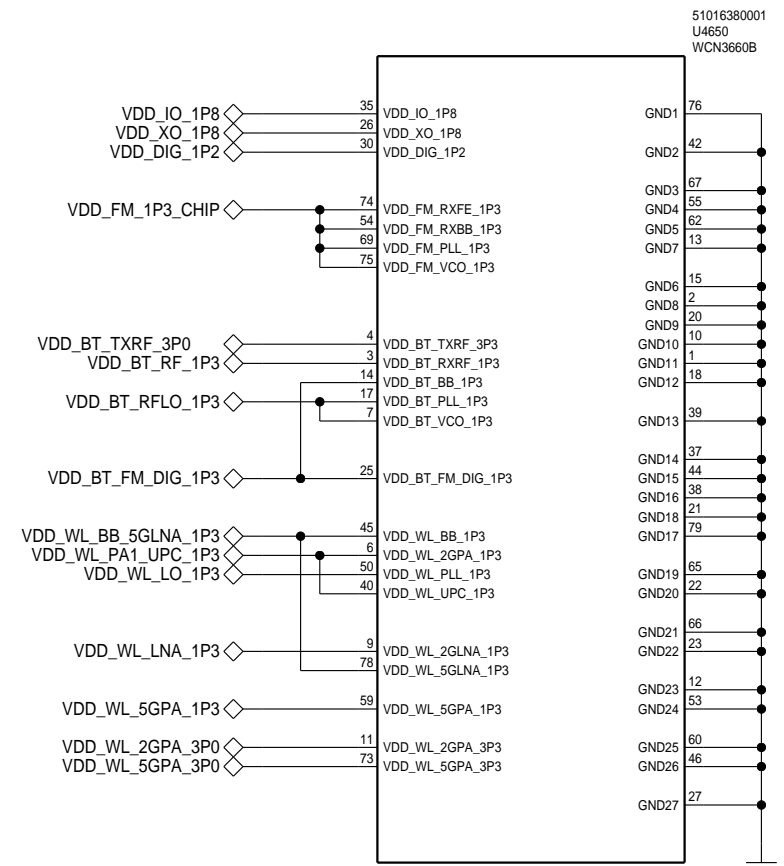
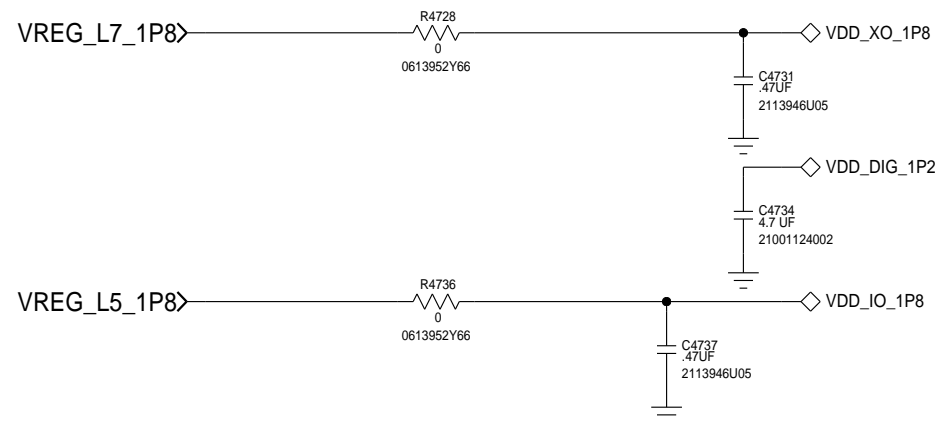

BASED ON 80-WL006-44 REV C

APPROVALS		MOTOROLA MOBILE DEVICES	
ENGINEER:		BLOCK TITLE:	
LAST MODIFIED BY: FROEHLING Thu May 05 16:54:45 2016		connectivity	
MOTOROLA CONFIDENTIAL RESTRICTED <small>THE DRAWING ON THIS PRINT AND INFORMATION THEREWITH ARE PROPRIETARY TO MOTOROLA AND SHALL NOT BE USED OR DISCUSSED IN WHOLE OR IN PART WITHOUT MOTOROLA'S CONSENT. © COPYRIGHT, MOTOROLA. THIS DOES NOT IMPLY PUBLICATION</small>		PROJECT NAME B 84016562001_a.cpm	REV 01
CAD FILE NAME:		PAGE 12 OF 61	

CONN: UIM1/UIM2/SDCARD

REF:4200-4219

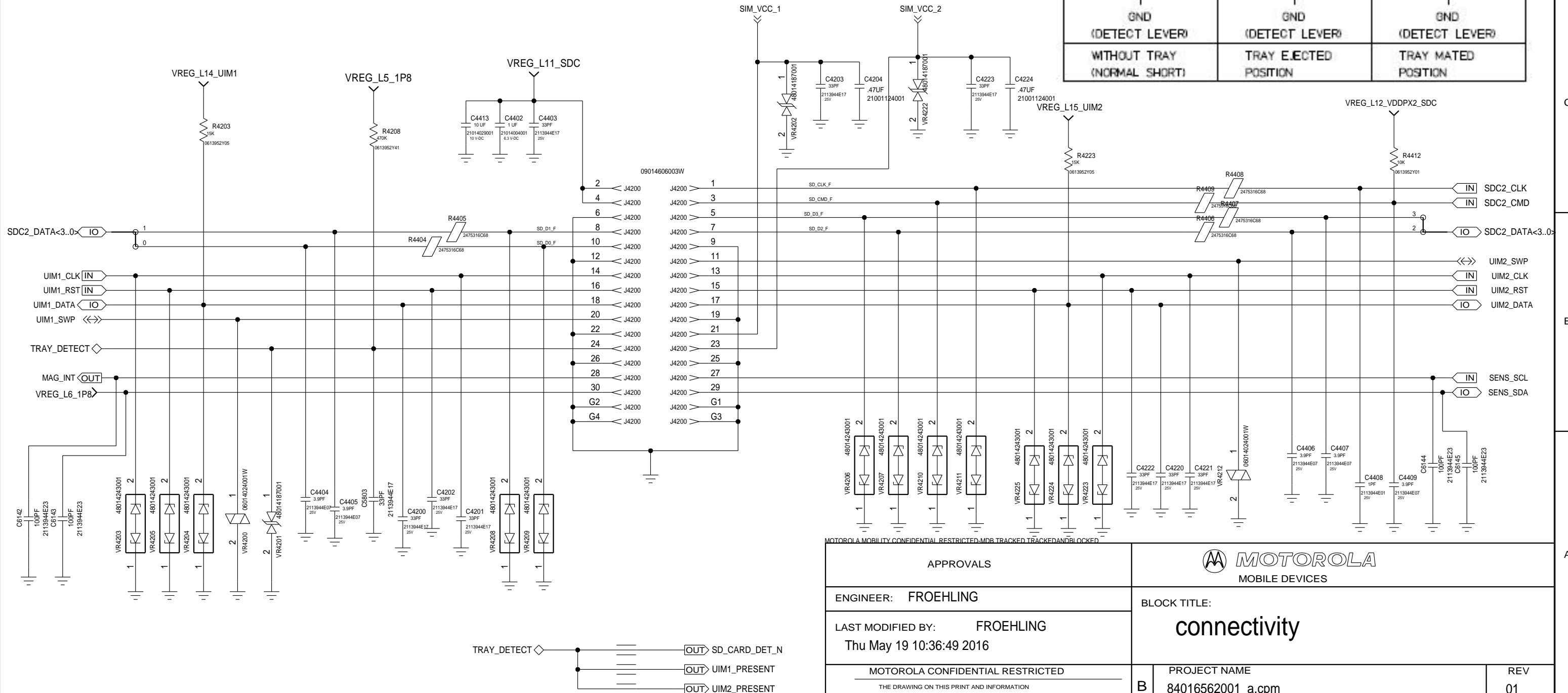
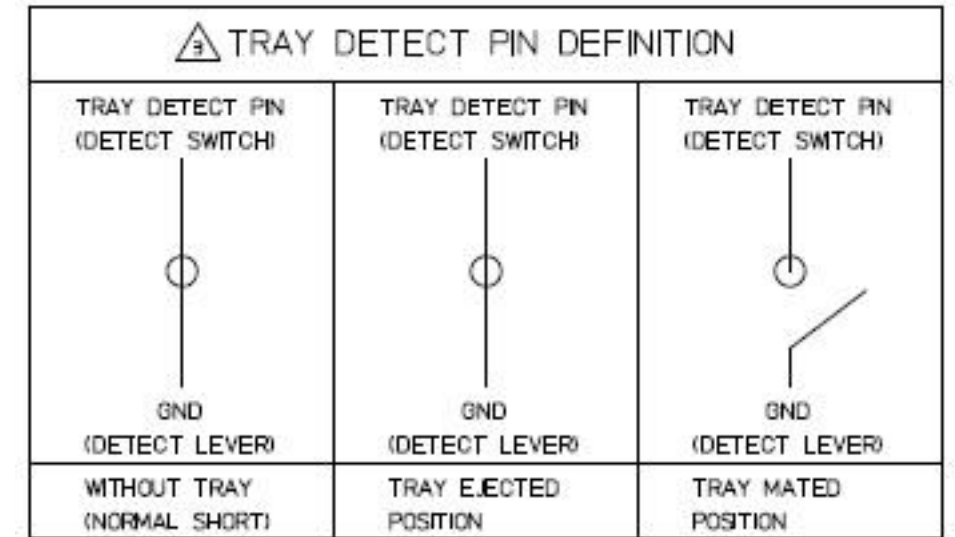

NOTE 1: USE 24.9K PULL-UP TO SUPPORT HOT SWAP WITH FREEZE-IO FEATURE.
 NOTE 2: UIM_PWR BYPASS OF 0.33UF RECOMMENDED BY NFC IC SUPPLIER, PLACE NEAR CONNECTOR.

APPROVALS		MOTOROLA MOBILE DEVICES	
ENGINEER: FROEHLING		BLOCK TITLE:	
LAST MODIFIED BY: FROEHLING Thu May 19 10:36:49 2016		connectivity	
MOTOROLA CONFIDENTIAL RESTRICTED		PROJECT NAME	REV
THE DRAWING ON THIS PRINT AND INFORMATION THEREWITH ARE PROPRIETARY TO MOTOROLA AND SHALL NOT BE USED OR DISCUSSED IN WHOLE OR IN PART WITHOUT MOTOROLA'S CONSENT. © COPYRIGHT, MOTOROLA. THIS DOES NOT IMPLY PUBLICATION		B 84016562001_a.cpm	01
CAD FILE NAME:		PAGE 13 OF 61	

USR: FPC

REF: 6600 - 6699

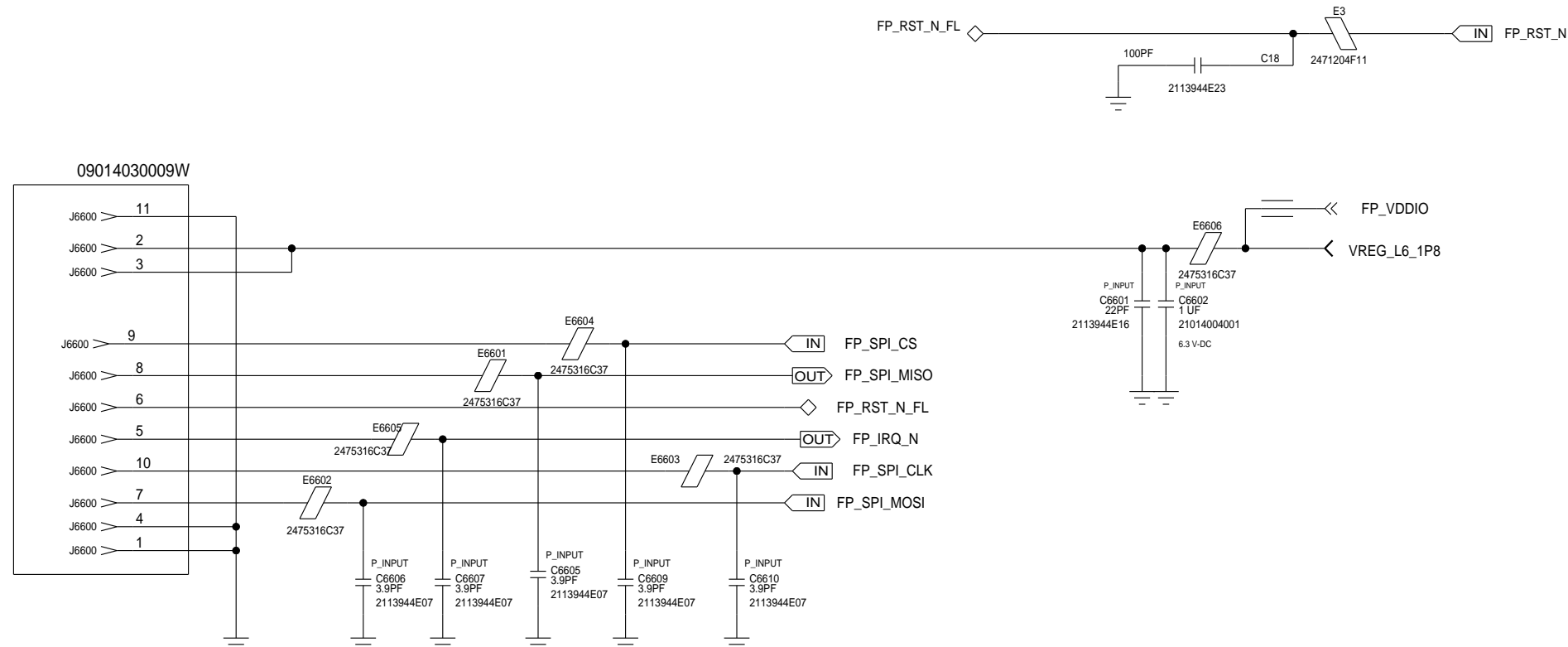

APPROVALS		MOTOROLA MOBILE DEVICES	
ENGINEER: NATE CONNELL		BLOCK TITLE:	
LAST MODIFIED BY: NATE CONNELL Thu May 05 16:54:47 2016		connectivity	
MOTOROLA CONFIDENTIAL RESTRICTED <small>THE DRAWING ON THIS PRINT AND INFORMATION THEREWITH ARE PROPRIETARY TO MOTOROLA AND SHALL NOT BE USED OR DISCUSSED IN WHOLE OR IN PART WITHOUT MOTOROLA'S CONSENT. © COPYRIGHT, MOTOROLA. THIS DOES NOT IMPLY PUBLICATION</small>		PROJECT NAME	REV
		B 84016562001_a.cpm	01
CAD FILE NAME:		PAGE 14 OF 61	

SIDE KEY & BATT THERM CONN

REF:5570-5579

MECHANICAL KEYS

VOL_UP/DOWN/GND TPS NEED P0 BRINGUP ONLY

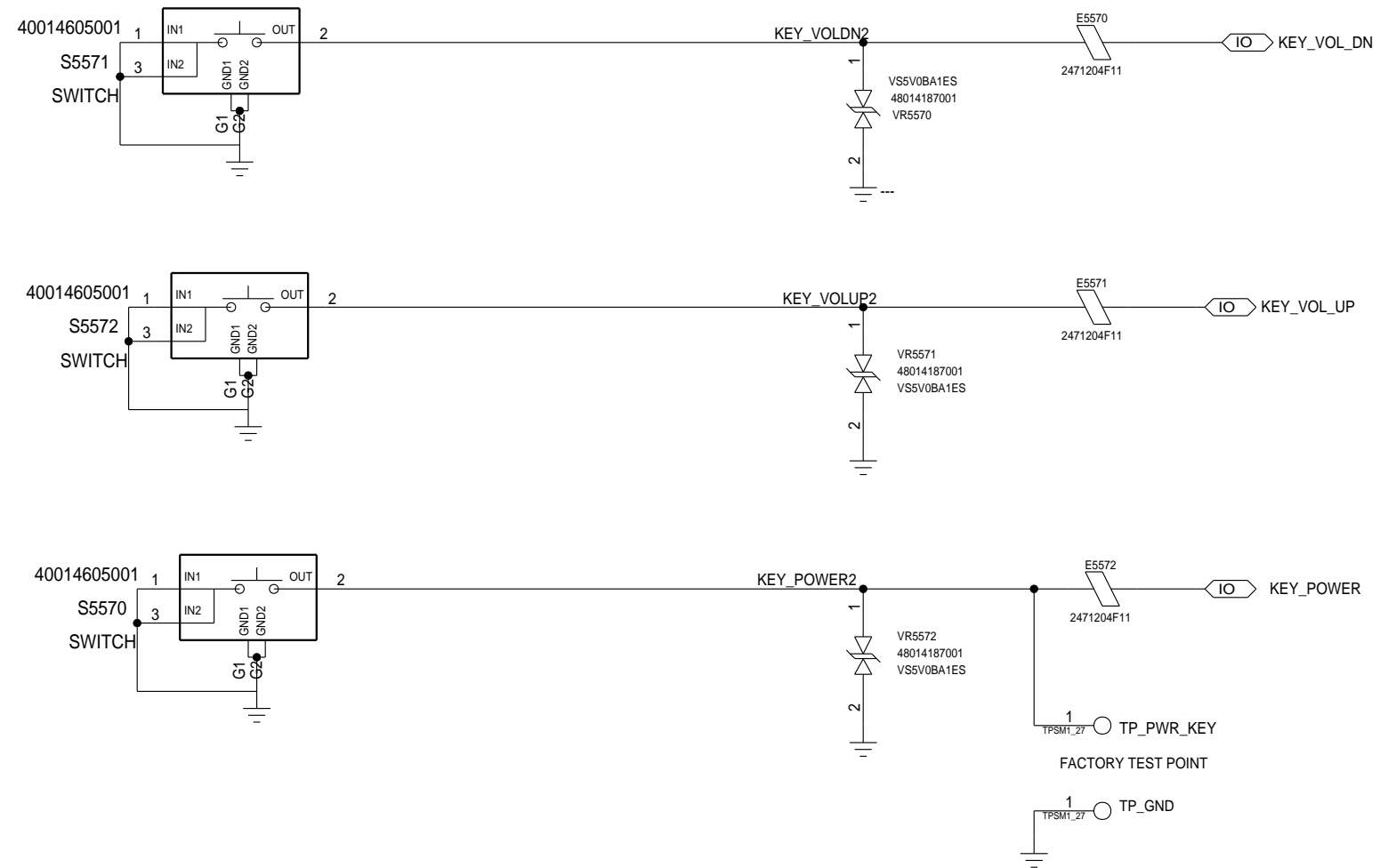

APPROVALS		MOTOROLA MOBILE DEVICES	
ENGINEER: NATE CONNELL		BLOCK TITLE:	
LAST MODIFIED BY: NATE CONNELL Thu May 05 16:54:48 2016		connectivity	
MOTOROLA CONFIDENTIAL RESTRICTED <small>THE DRAWING ON THIS PRINT AND INFORMATION THEREWITH ARE PROPRIETARY TO MOTOROLA AND SHALL NOT BE USED OR DISCUSSED IN WHOLE OR IN PART WITHOUT MOTOROLA'S CONSENT. © COPYRIGHT, MOTOROLA. THIS DOES NOT IMPLY PUBLICATION</small>		PROJECT NAME	REV
		B 84016562001_a.cpm	01
		CAD FILE NAME:	
		PAGE 15 OF 61	

CONN: NXP NFC

REF: 4100-4199

PN548 I2C ADDRESS MAP

HIF2	HIF1	WRITE	READ
LOW	LOW	0X50	0X51
LOW	HIGH	0X52	0X53
HIGH	LOW	0X54	0X55
HIGH	HIGH	0X56	0X57

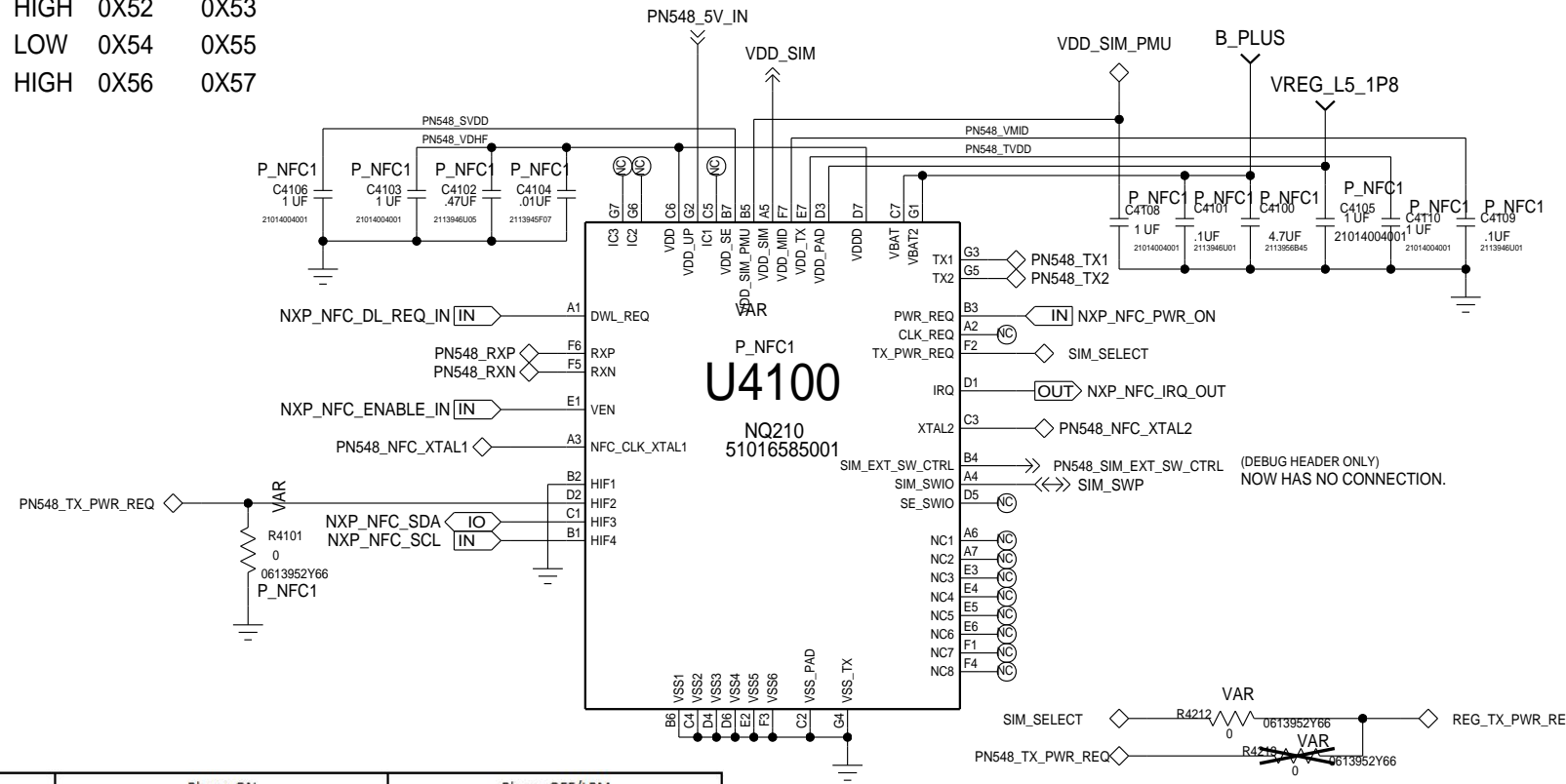

	Phone ON (Vreg_L5_1p8 = HIGH)		Phone OFF/LPM (Vreg_L5_1p8 = LOW)	
	SIM_Select (LOW = SIM 1)	SIM_Select (High = SIM 2)	SIM_Select (LOW = SIM 1)	SIM_Select (High = SIM 2)
VDD_SIM_PMU	Vreg_L14_UIM1 4Z-4Y0	Vreg_L15_UIM2 4Z-4Y1	No power from PMU 4Z-4Y0-Open	No power from PMU 4Z-4Y1-Open
VDD_SIM	No connect	No connect	SIM_VCC1	SIM_VCC2
SIM_VCC_1	Vreg_L14_UIM1 1Z-1Y1	Vreg_L15_UIM1 1Z-1Y1	3Z-3Y0-1Y0-1Z	3Z-3Y1-2Y0-2Z
SIM_VCC_2	Vreg_L15_UIM2 2Z-2Y1	Vreg_L15_UIM2 2Z-2Y1	Not connected	VDD_SIM
UIM1_SWAP	SIM_SWAP	Not connected	SIM_SWAP	Not connected
UIM2_SWAP	Not connected	SIM_SWAP	Not connected	SIM_SWAP

CHINA: DNP - R4101/R4102/R4103/R4204/R4210/R4212, PLACE - U4130/U4140/C4132/C4133/R4213
OTHER SKUS: PLACE - R4101/R4102/R4103/R4204/R4210/R4212, DNP - U4130/U4140/C4132/C4133/R4213

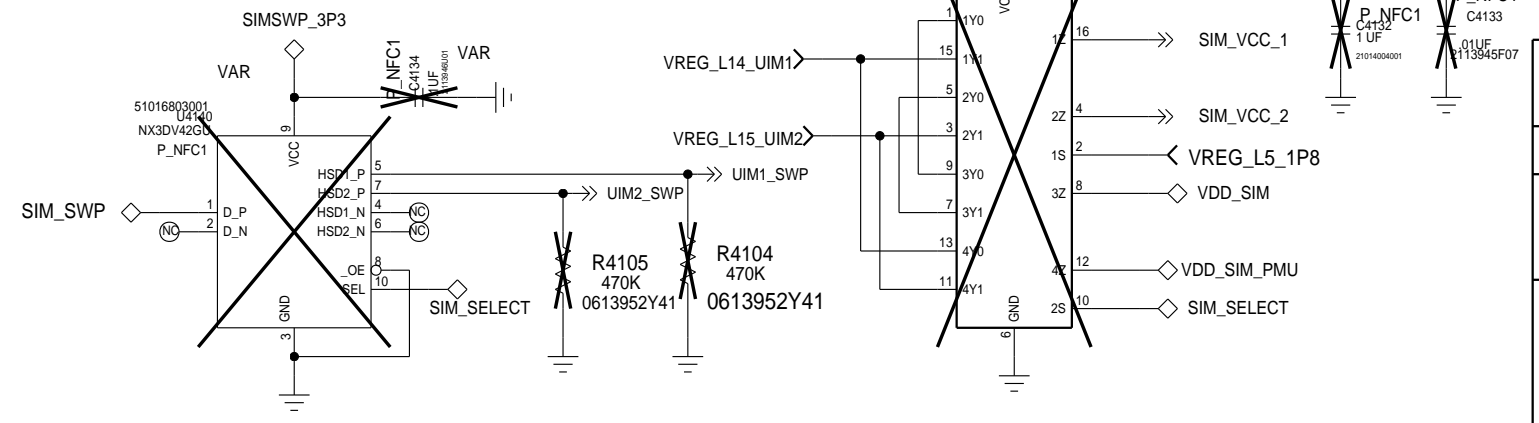
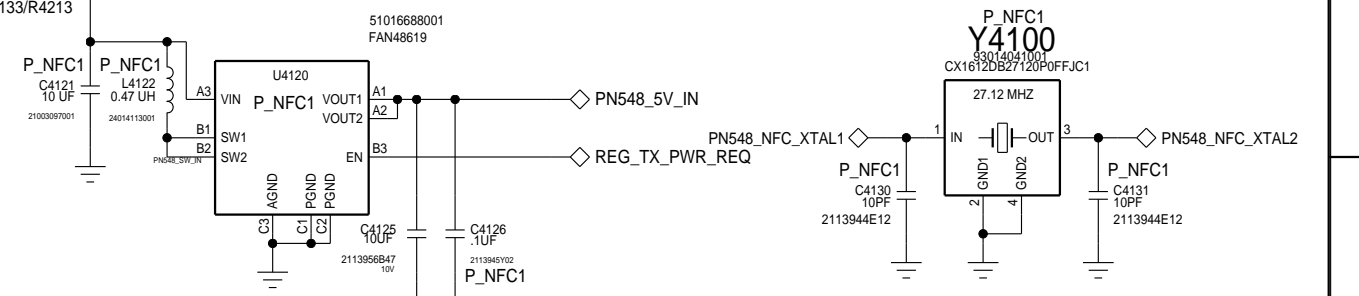
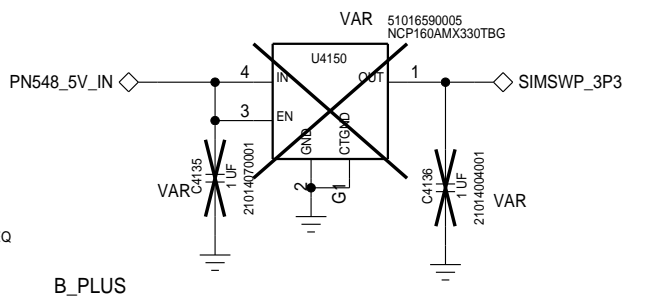
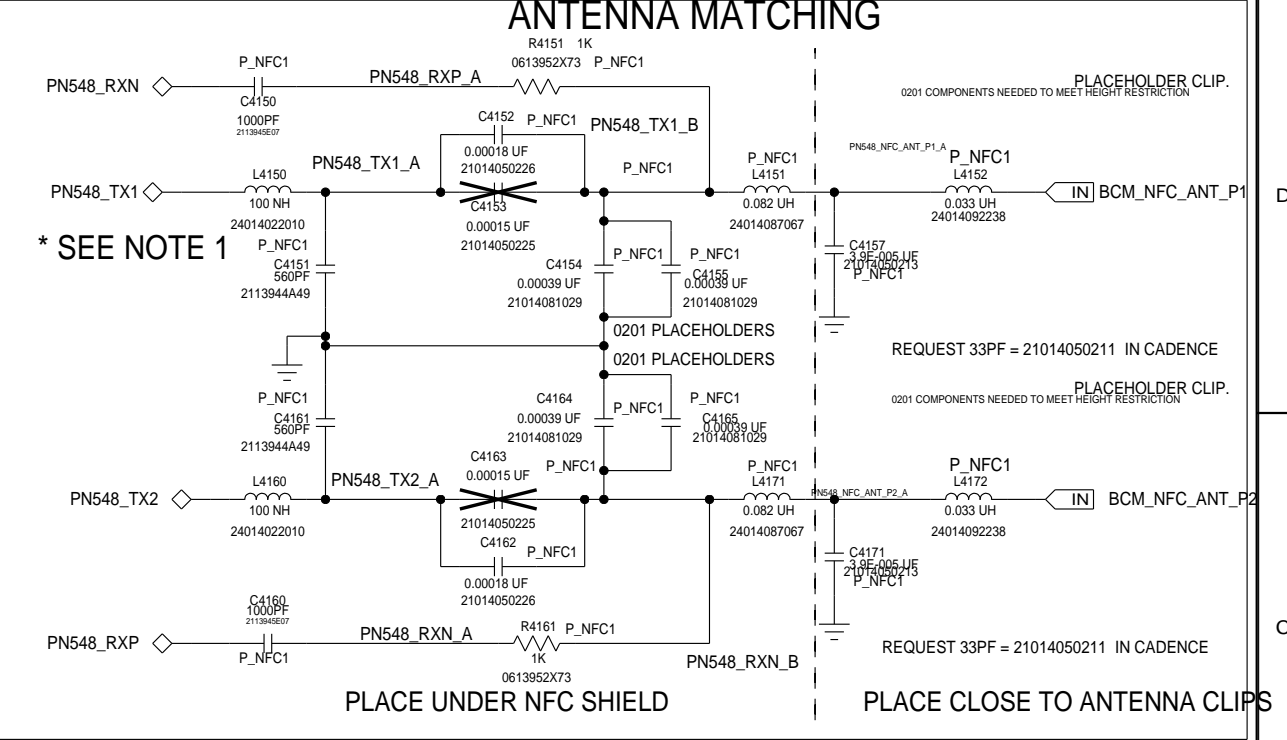
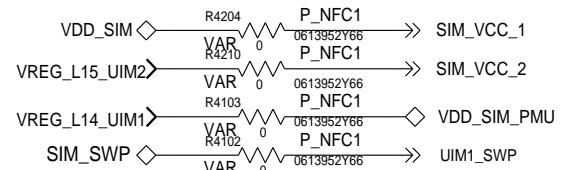

APPROVALS	
ENGINEER: FROEHLING	
LAST MODIFIED BY: FROEHLING Thu May 19 12:03:57 2016	BLOCK TITLE: connectivity
MOTOROLA CONFIDENTIAL RESTRICTED THE DRAWING ON THIS PRINT AND INFORMATION THEREWITH ARE PROPRIETARY TO MOTOROLA AND SHALL NOT BE USED OR DISCUSSED IN WHOLE OR IN PART WITHOUT MOTOROLA'S CONSENT. COPYRIGHT, MOTOROLA. THIS DOES NOT IMPLY PUBLICATION	PROJECT NAME 84016562001_a.cpm
	REV 01
	CAD FILE NAME: PAGE 16 OF 61

XMCS: CCP

REF: 6000-6049

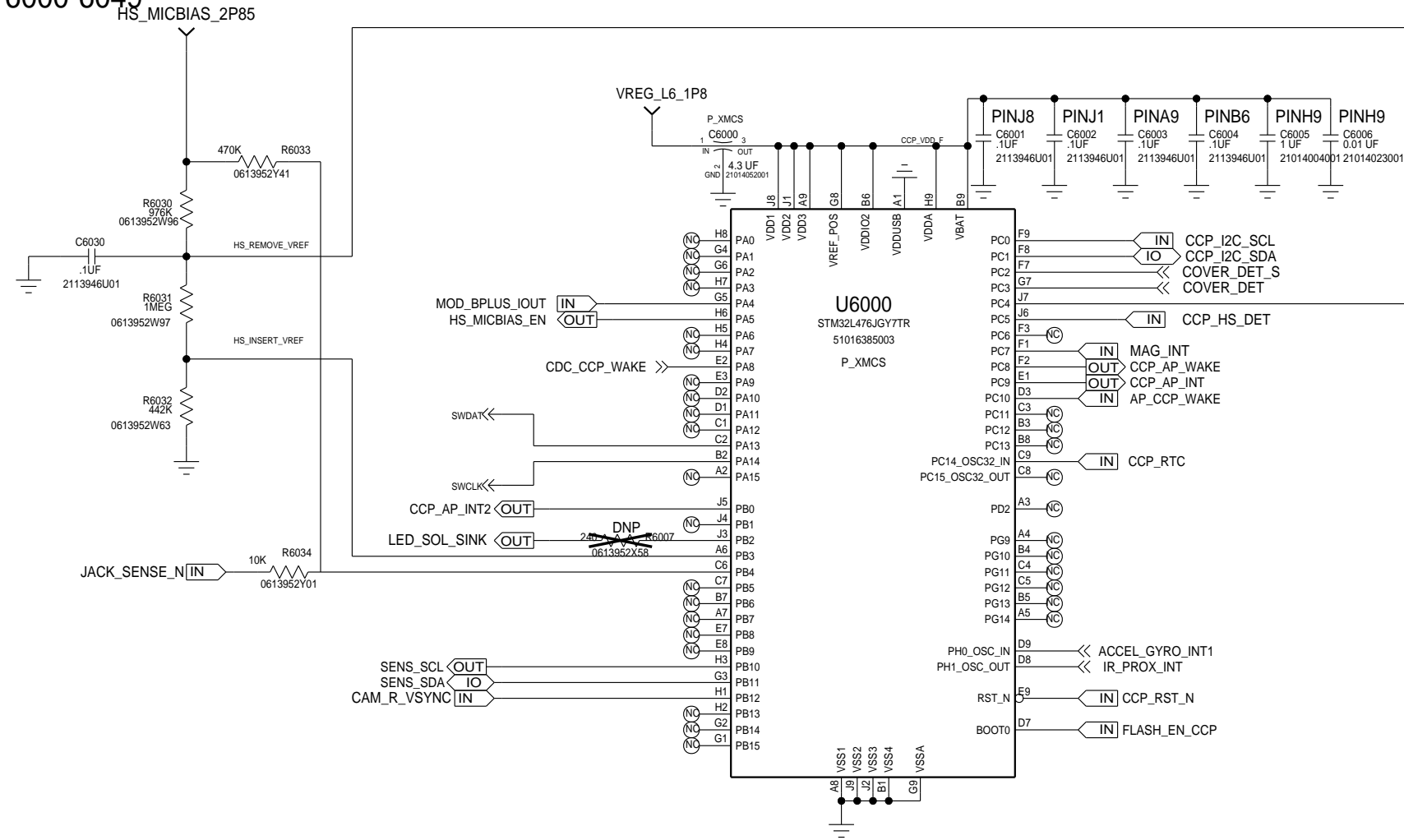

I2C SUPPORT

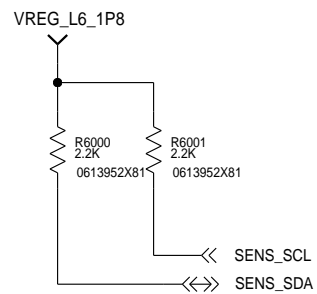

TESTPOINTS

APPROVALS		MOTOROLA MOBILE DEVICES	
ENGINEER: JOHN GORSICA		BLOCK TITLE:	
LAST MODIFIED BY: NATE CONNELL Thu May 05 16:54:41 2016		xmcs	
MOTOROLA CONFIDENTIAL RESTRICTED <small>THE DRAWING ON THIS PRINT AND INFORMATION THEREWITH ARE PROPRIETARY TO MOTOROLA AND SHALL NOT BE USED OR DISCUSSED IN WHOLE OR IN PART WITHOUT MOTOROLA'S CONSENT. © COPYRIGHT, MOTOROLA. THIS DOES NOT IMPLY PUBLICATION</small>		PROJECT NAME B 84016562001_a.cpm	REV 01
		CAD FILE NAME:	
		PAGE 17 OF 61	

XMCS: SENSORS

REF: 6100-6199

PROX SENSOR/ALS INTERFACE

REF:6190-6199
I2C ADDR:0X39

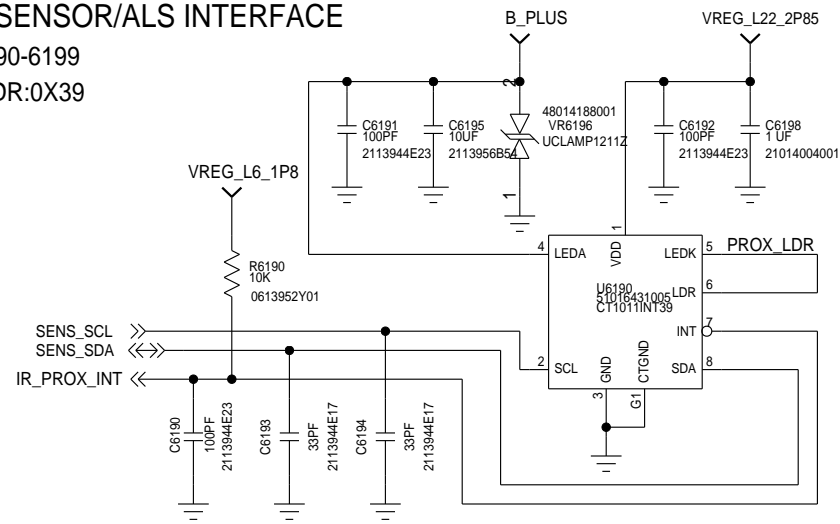

BOARD TEMP SENSOR

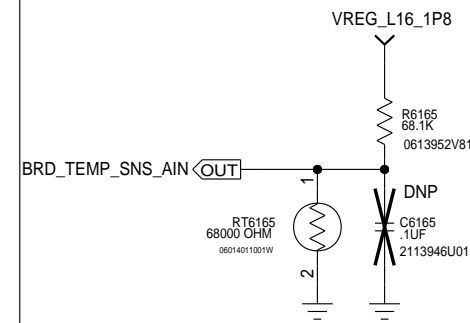

CHRG TEMP SENSOR

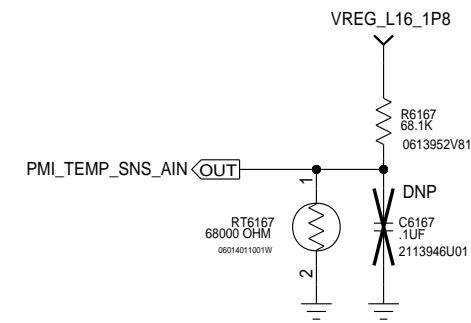

HALL EFFECT SENSOR

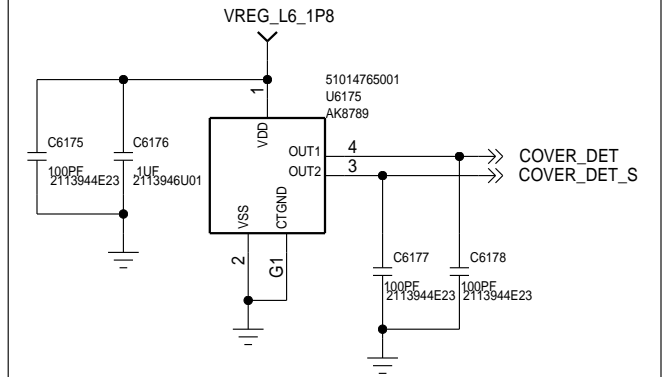

ACCELEROMETER+GYRO

REF:6150-6159
I2C ADDR: 0X??

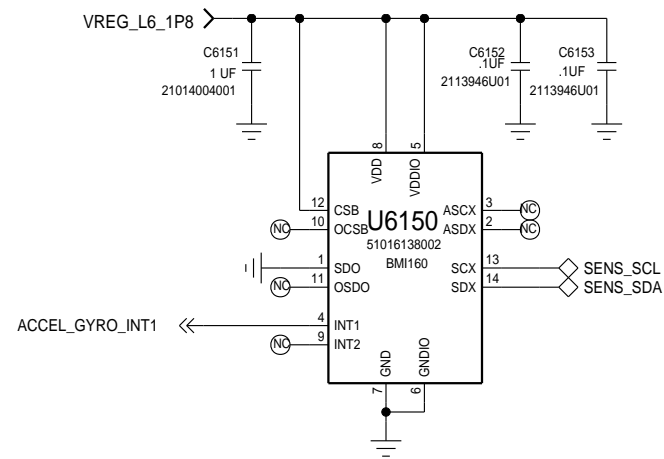

PRODUCTS MUST FOLLOW BUNKER HILL PCB ORIENTATION

MAGNETOMETER

REF:6140-6149
I2C ADDR: 0X0C

MOVED TO SIM FLEX PCB FROM DVT2

JOHN GORSICA/NATE CONNELL
APPROVALS



ENGINEER: HUNG PHAM

BLOCK TITLE:

LAST MODIFIED BY: HUNG PHAM
Wed Jun 01 10:59:04 2016

xmcs

MOTOROLA CONFIDENTIAL RESTRICTED

THE DRAWING ON THIS PRINT AND INFORMATION
THEREWITH ARE PROPRIETARY TO MOTOROLA AND
SHALL NOT BE USED OR DISCUSSED IN WHOLE
OR IN PART WITHOUT MOTOROLA'S CONSENT.

PROJECT NAME
84016562001_a.cpm

REV
01

CAD FILE NAME:

PAGE 18 OF 61

MOTOROLA MOBILITY CONFIDENTIAL RESTRICTED-MDB TRACKED © 2016 MOTOROLA. THIS DOES NOT IMPLY PUBLICATION

XMCS: SMART BOOST WATTSON

REF 6400-6499

*** BOOST IC I2C ADD. 0X80

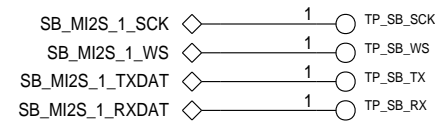
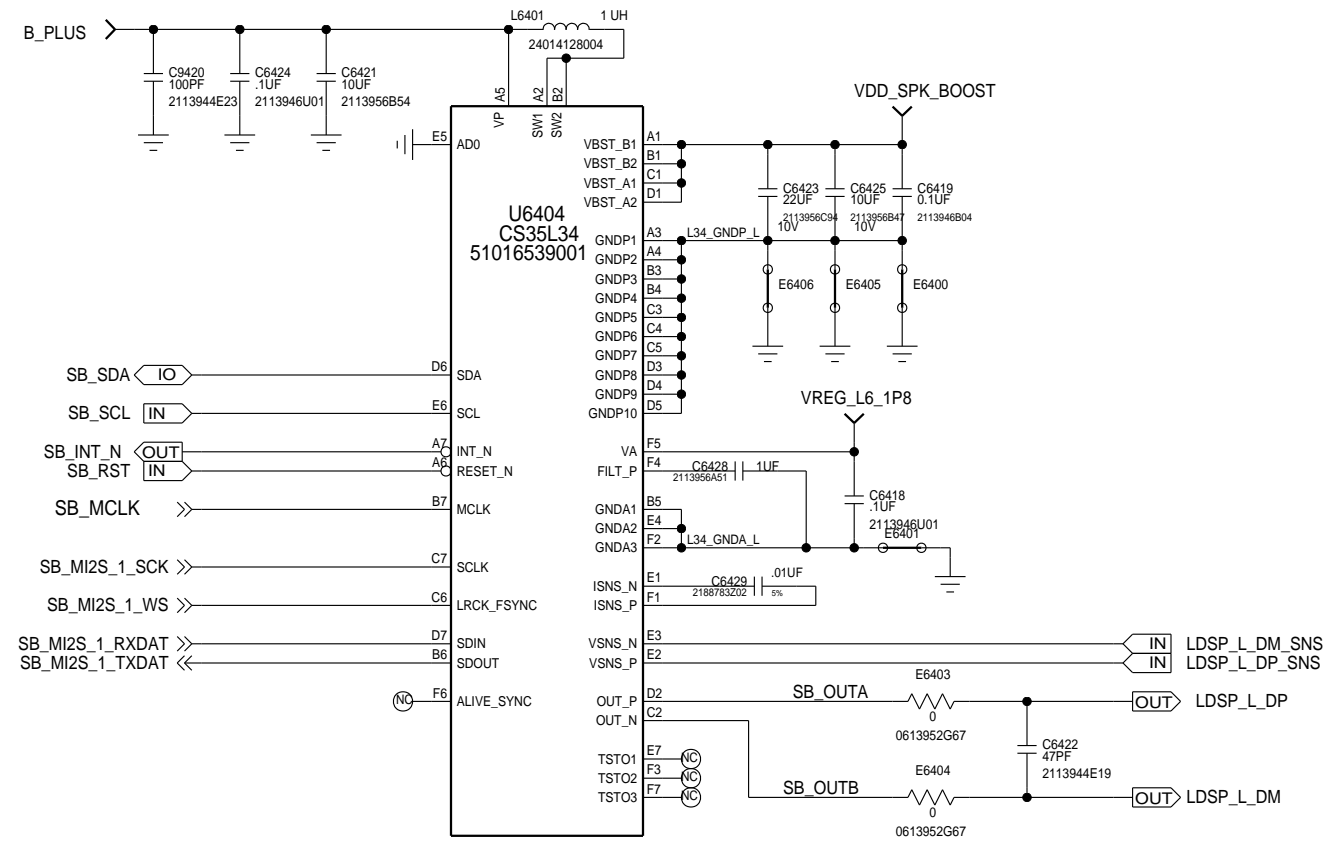

APPROVALS		MOTOROLA MOBILE DEVICES	
ENGINEER:		BLOCK TITLE:	
LAST MODIFIED BY: Mon May 23 19:04:04 2016		xmcs	
MOTOROLA CONFIDENTIAL RESTRICTED <small>THE DRAWING ON THIS PRINT AND INFORMATION THEREWITH ARE PROPRIETARY TO MOTOROLA AND SHALL NOT BE USED OR DISCUSSED IN WHOLE OR IN PART WITHOUT MOTOROLA'S CONSENT. © COPYRIGHT, MOTOROLA. THIS DOES NOT IMPLY PUBLICATION</small>		PROJECT NAME B 84016562001_a.cpm	REV 01
		CAD FILE NAME:	
		PAGE 19 OF 61	

XMCS: CIRRUS CODEC

REF 6250-6299

*** CODEC I2C ADD. 0X34

D

C

B

A

D

C

B

A

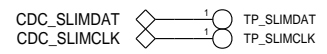
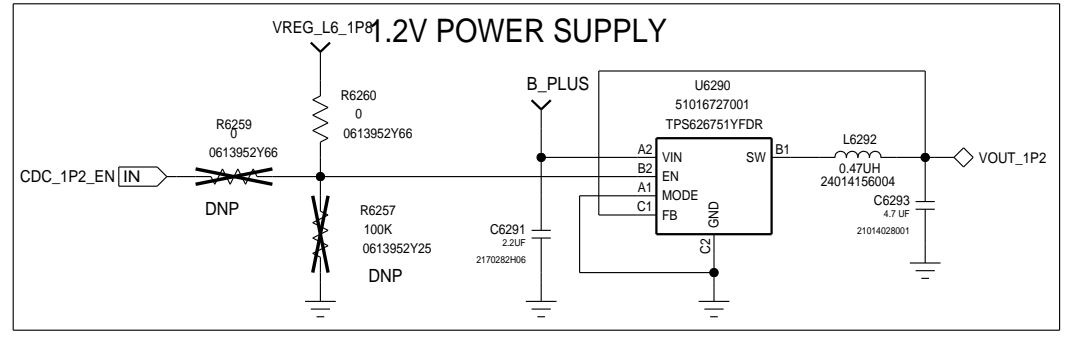
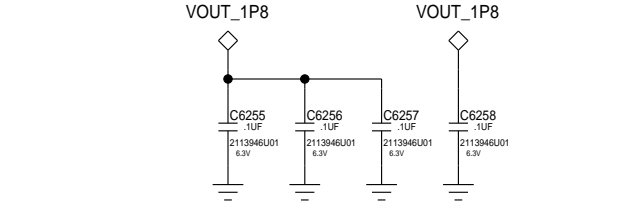
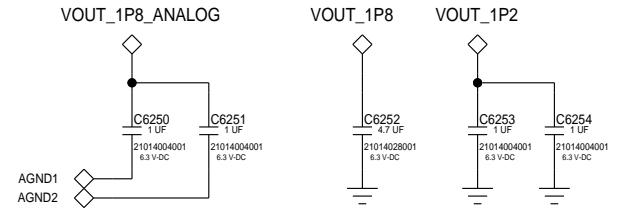
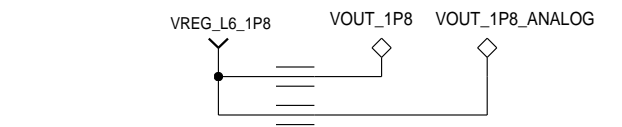
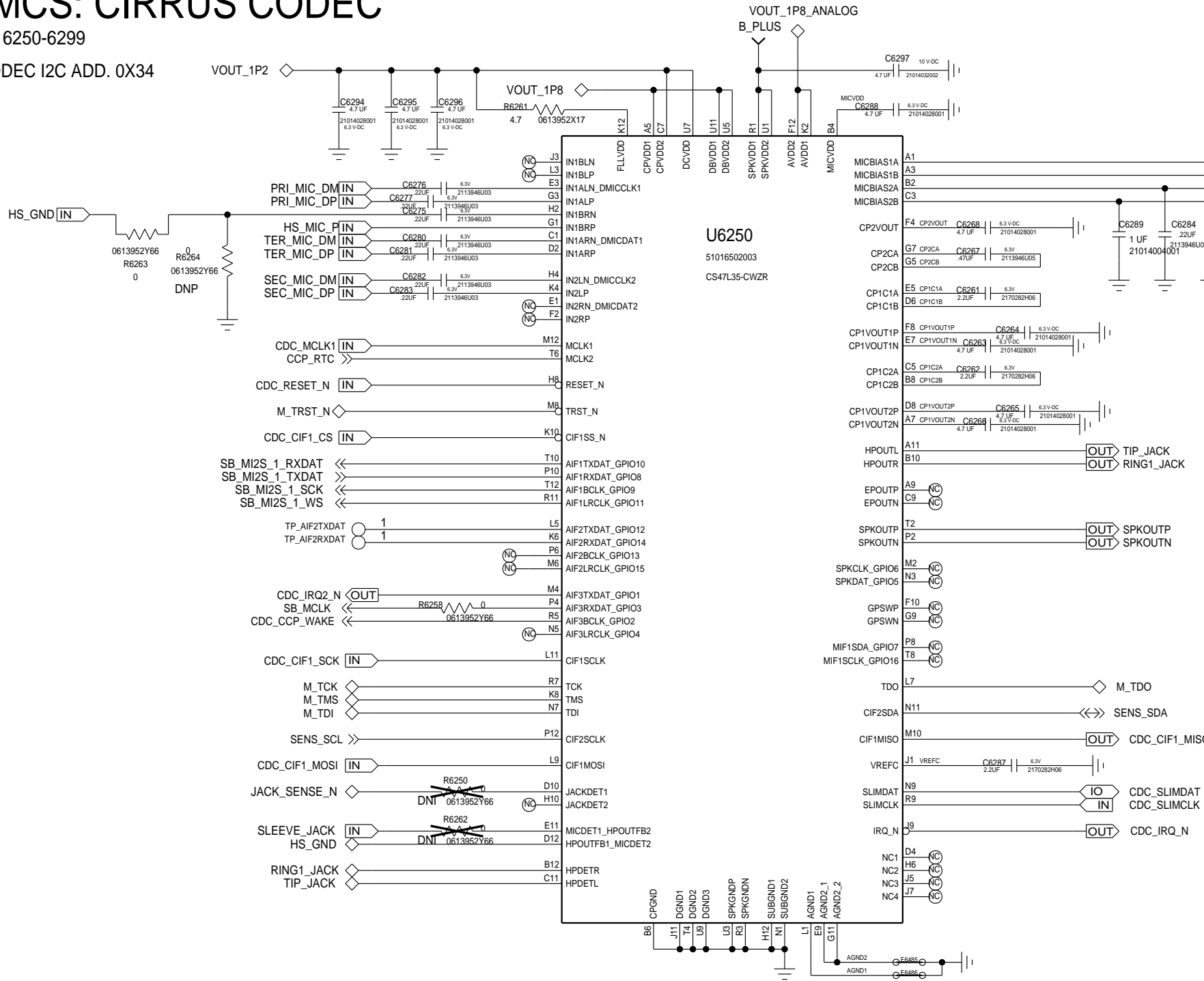

APPROVALS		MOTOROLA MOBILE DEVICES	
ENGINEER:		BLOCK TITLE:	
LAST MODIFIED BY: FAN021 Tue May 24 15:07:05 2016		xmcs	
MOTOROLA CONFIDENTIAL RESTRICTED <small>THE DRAWING ON THIS PRINT AND INFORMATION THEREWITH ARE PROPRIETARY TO MOTOROLA AND SHALL NOT BE USED OR DISCUSSED IN WHOLE OR IN PART WITHOUT MOTOROLA'S CONSENT. © COPYRIGHT, MOTOROLA. THIS DOES NOT IMPLY PUBLICATION</small>		PROJECT NAME B 84016562001_a.cpm	REV 01
CAD FILE NAME:		PAGE 20 OF 61	

XMCS: PMIC CODEC

REF 2500-2579

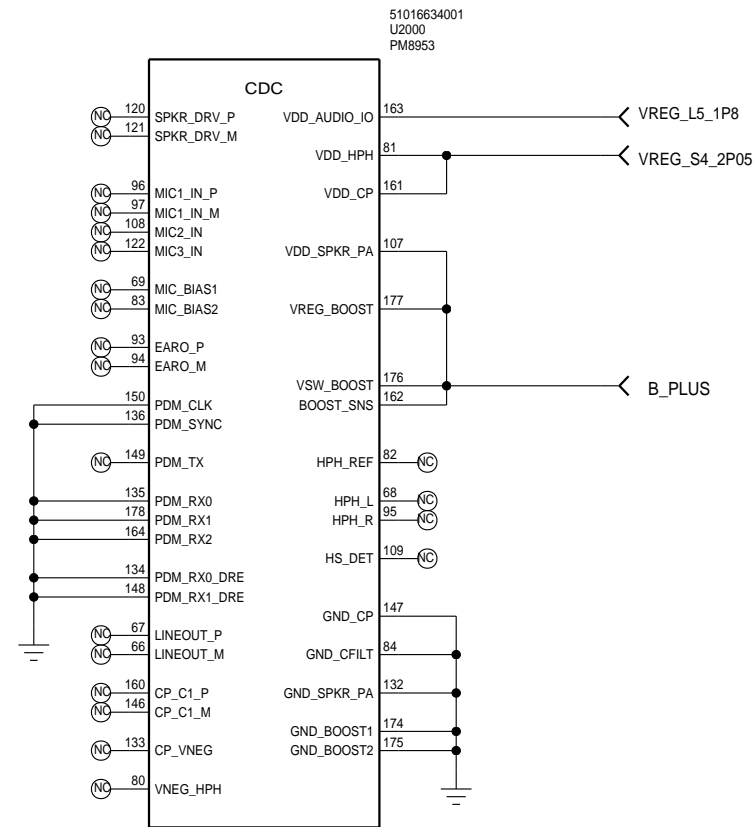

APPROVALS		 MOTOROLA MOBILE DEVICES	
ENGINEER:		BLOCK TITLE:	
LAST MODIFIED BY: FAN021 Thu May 05 16:54:43 2016		xmcs	
MOTOROLA CONFIDENTIAL RESTRICTED <small>THE DRAWING ON THIS PRINT AND INFORMATION THEREWITH ARE PROPRIETARY TO MOTOROLA AND SHALL NOT BE USED OR DISCUSSED IN WHOLE OR IN PART WITHOUT MOTOROLA'S CONSENT. © COPYRIGHT, MOTOROLA. THIS DOES NOT IMPLY PUBLICATION</small>		PROJECT NAME B 84016562001_a.cpm	REV 01
		CAD FILE NAME:	
		PAGE 21 OF 61	

8

7

6

5

4

3

2

1

XMCS: IR GESTURES

REF 6500-6549

D

D

C

C

B

B

A

A

MOTOROLA MOBILITY CONFIDENTIAL RESTRICTED-MDB TRACKED TRACKEDANDBLOCKED

APPROVALS		 MOTOROLA MOBILE DEVICES	
ENGINEER: MATT MOTTIER		BLOCK TITLE:	
LAST MODIFIED BY: UDI ELRAN Mon Dec 28 15:04:31 2015		xmcs	
MOTOROLA CONFIDENTIAL RESTRICTED <small>THE DRAWING ON THIS PRINT AND INFORMATION THEREWITH ARE PROPRIETARY TO MOTOROLA AND SHALL NOT BE USED OR DISCUSSED IN WHOLE OR IN PART WITHOUT MOTOROLA'S CONSENT. © COPYRIGHT, MOTOROLA. THIS DOES NOT IMPLY PUBLICATION</small>		PROJECT NAME B 84016562001_a.cpm	REV 01
		CAD FILE NAME:	PAGE 22 OF 61

8

7

6

5

4

3

2

1

MSM: CTRL

REF 1000-1099

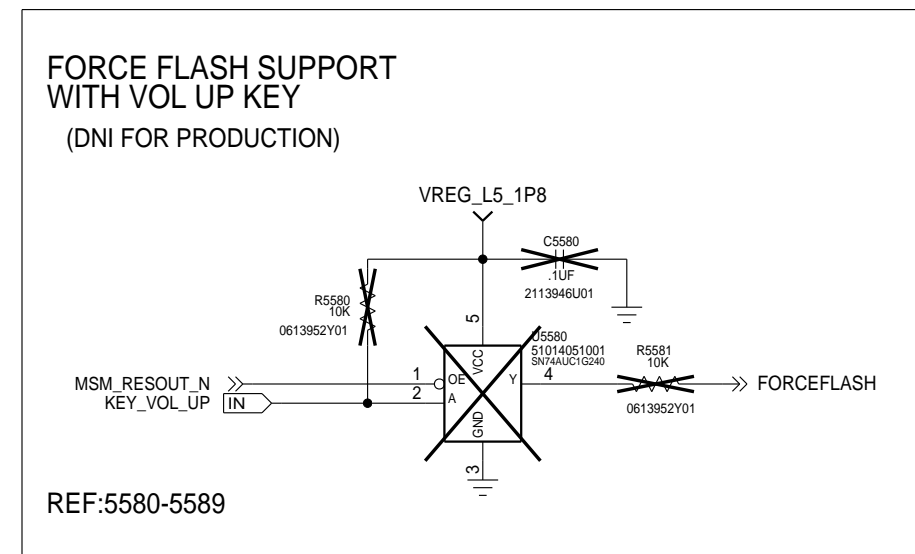
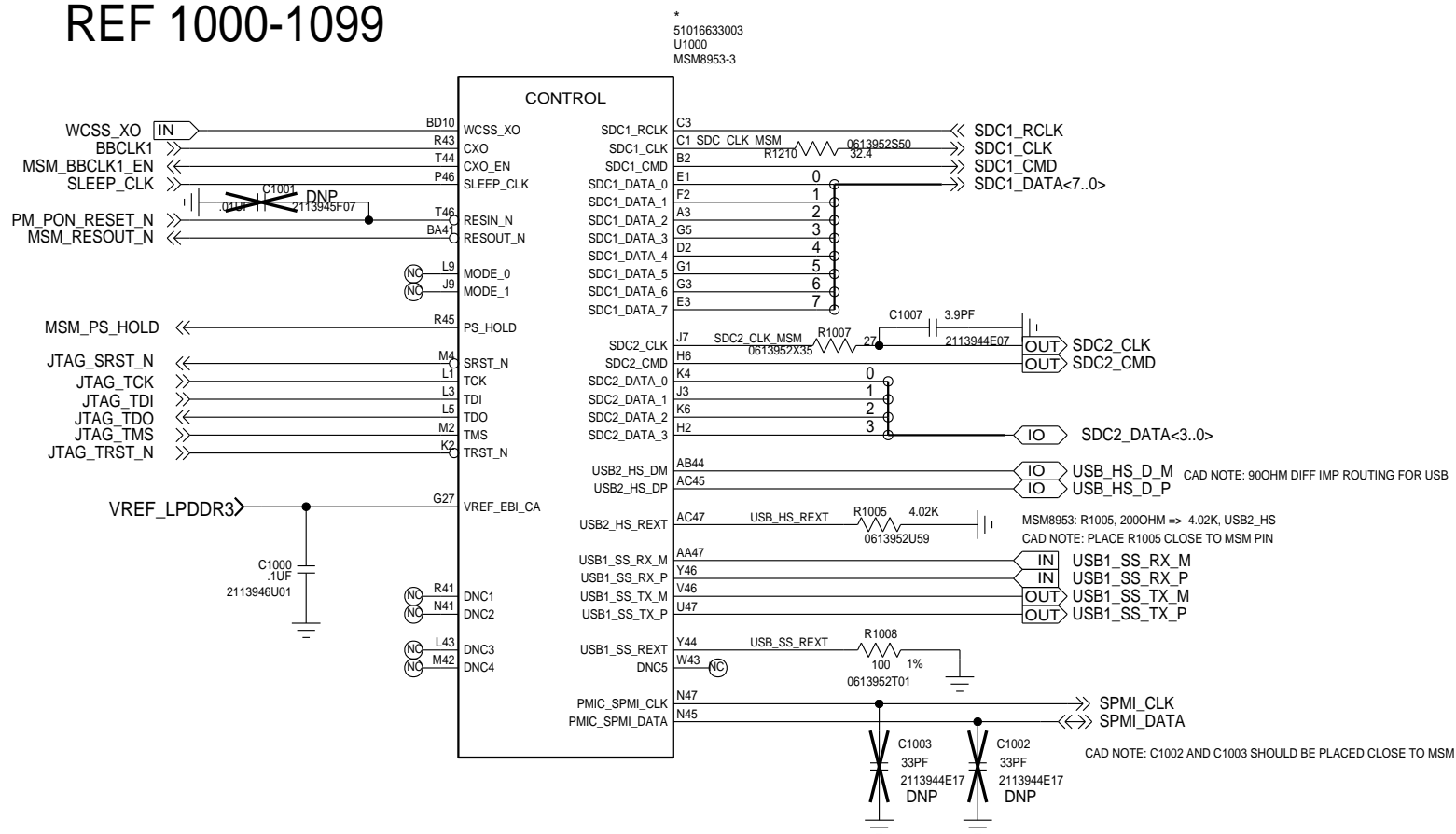

APPROVALS		MOTOROLA MOBILE DEVICES	
ENGINEER:		BLOCK TITLE:	
LAST MODIFIED BY: FAN021 Thu May 05 16:54:28 2016		ap_pmic	
MOTOROLA CONFIDENTIAL RESTRICTED THE DRAWING ON THIS PRINT AND INFORMATION THEREWITH ARE PROPRIETARY TO MOTOROLA AND SHALL NOT BE USED OR DISCUSSED IN WHOLE OR IN PART WITHOUT MOTOROLA'S CONSENT. © COPYRIGHT, MOTOROLA. THIS DOES NOT IMPLY PUBLICATION		PROJECT NAME	REV
		B 84016562001_a.cpm	01
CAD FILE NAME:		PAGE 23 OF 61	

MSM: DEBUG

REF 1000-1099

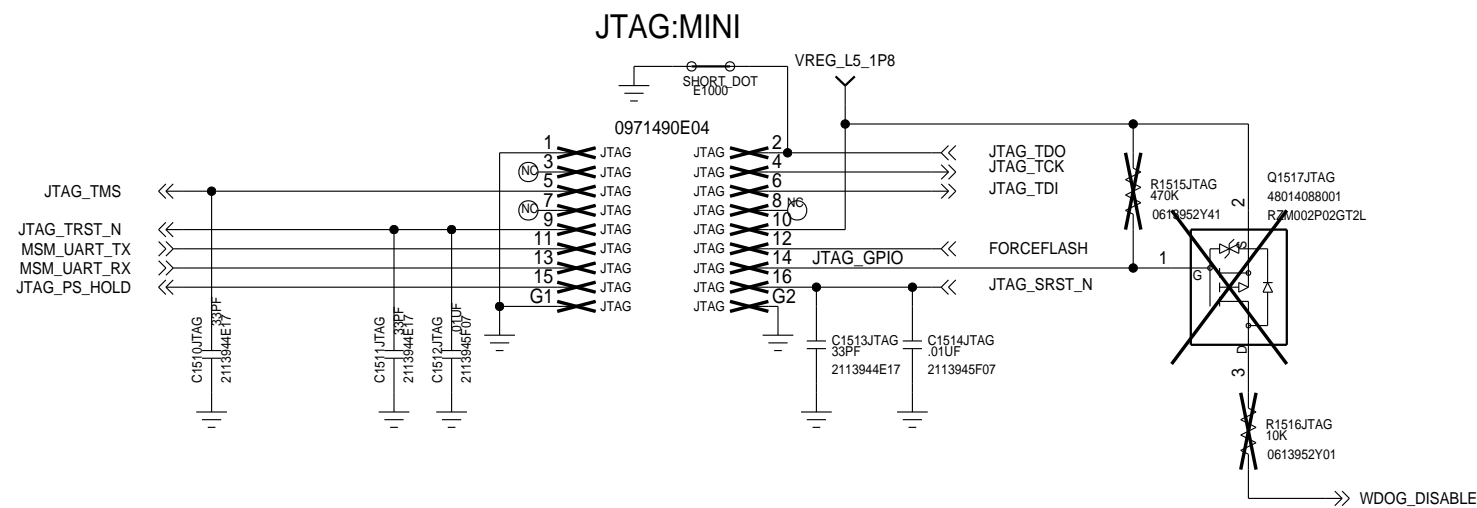

APPROVALS		MOTOROLA MOBILE DEVICES	
ENGINEER:		BLOCK TITLE:	
LAST MODIFIED BY: FAN021 Thu May 05 16:54:28 2016		ap_pmic	
MOTOROLA CONFIDENTIAL RESTRICTED THE DRAWING ON THIS PRINT AND INFORMATION THEREWITH ARE PROPRIETARY TO MOTOROLA AND SHALL NOT BE USED OR DISCUSSED IN WHOLE OR IN PART WITHOUT MOTOROLA'S CONSENT. © COPYRIGHT, MOTOROLA. THIS DOES NOT IMPLY PUBLICATION		PROJECT NAME	REV
		B 84016562001_a.cpm	01
CAD FILE NAME:		PAGE 24 OF 61	

MSM: MIPI/DSI/CSI/EBIO

REF 1200-1299

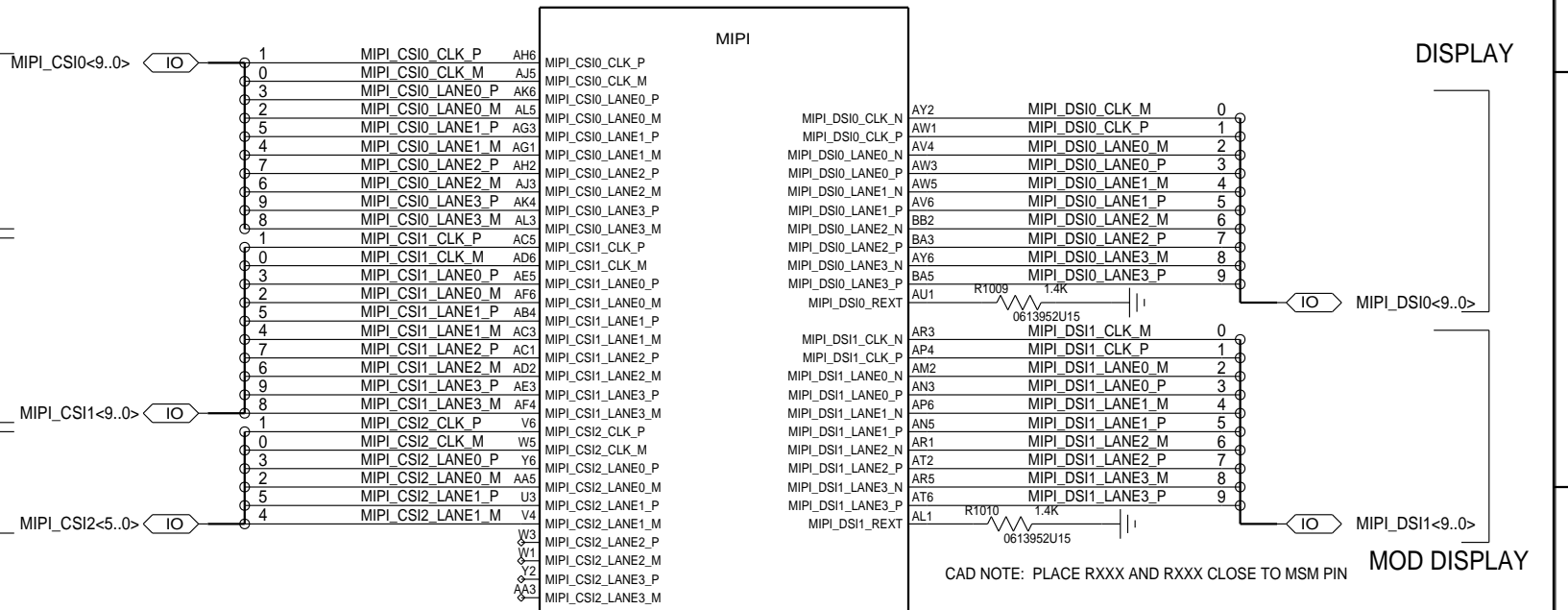
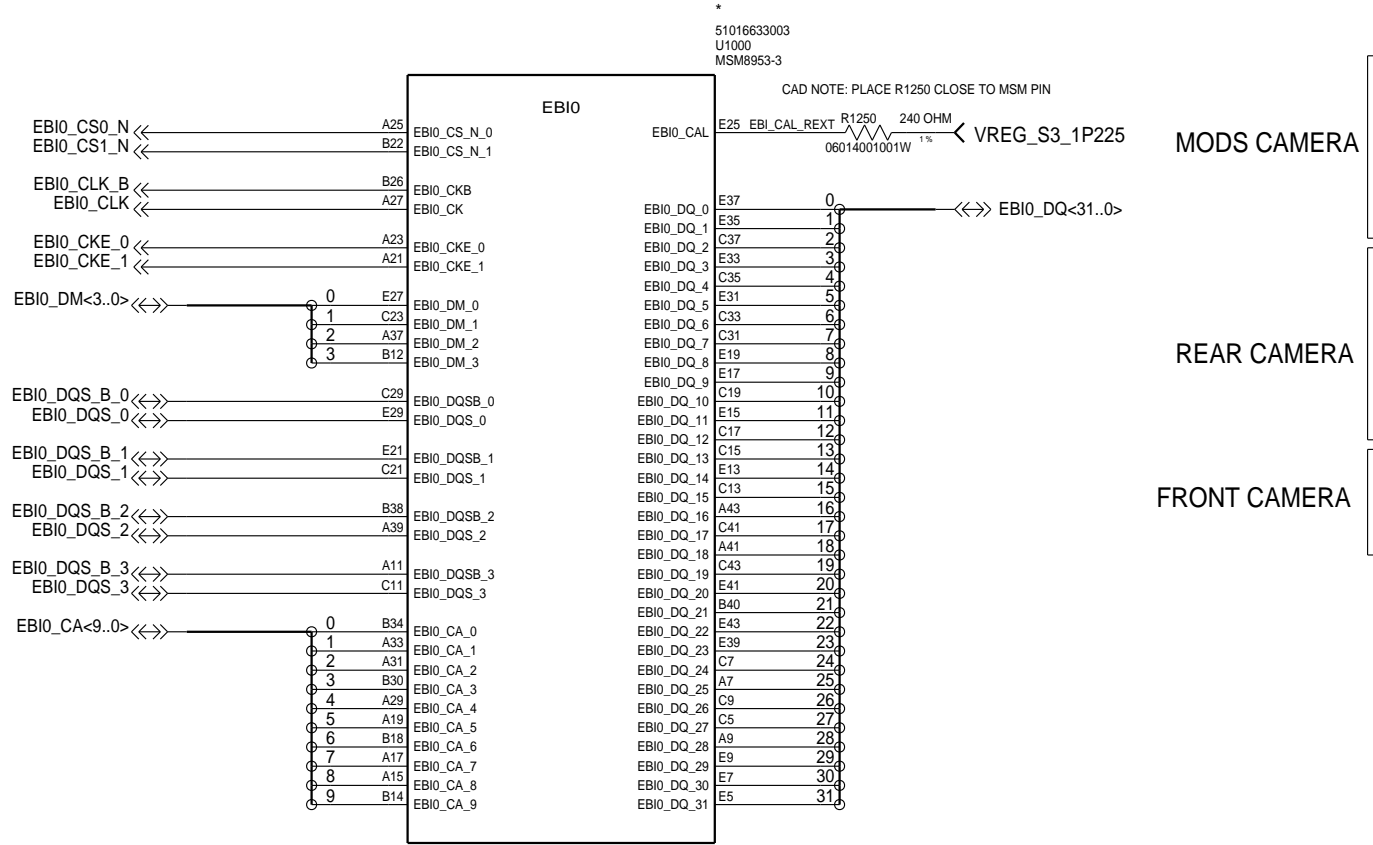

APPROVALS		MOTOROLA MOBILE DEVICES	
ENGINEER:		BLOCK TITLE:	
LAST MODIFIED BY: Thu May 05 16:54:29 2016		ap_pmic	
MOTOROLA CONFIDENTIAL RESTRICTED <small>THE DRAWING ON THIS PRINT AND INFORMATION THEREWITH ARE PROPRIETARY TO MOTOROLA AND SHALL NOT BE USED OR DISCUSSED IN WHOLE OR IN PART WITHOUT MOTOROLA'S CONSENT. © COPYRIGHT, MOTOROLA. THIS DOES NOT IMPLY PUBLICATION</small>		PROJECT NAME B 84016562001_a.cpm	REV 01
		CAD FILE NAME:	
		PAGE 25 OF 61	

MSM: GPIO (0-141)

REF 1200-1299

NOTE: DO NOT HAVE PULL-UPS ON THE FOLLOWING GPIOs UNLESS INTEND FOR BOOT OR SECURE BOOT RELATED CONFIGURATIONS:
GPIO_8, 9, 91, 107, 108, 109

NOTE: ASTERISK(*) INDICATE MODEM POWER MANAGEMENT (MPM) WAKE-UP PINS.

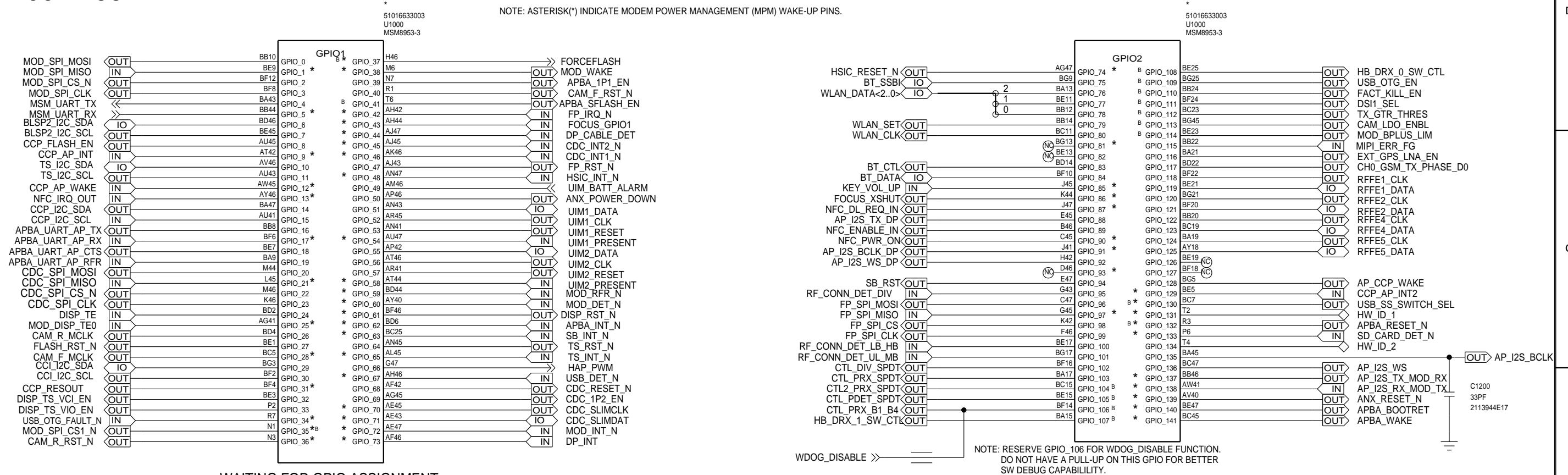

WAITING FOR GPIO ASSIGNMENT
NEED WAKABLE

I2C PULL-UP RESISTORS

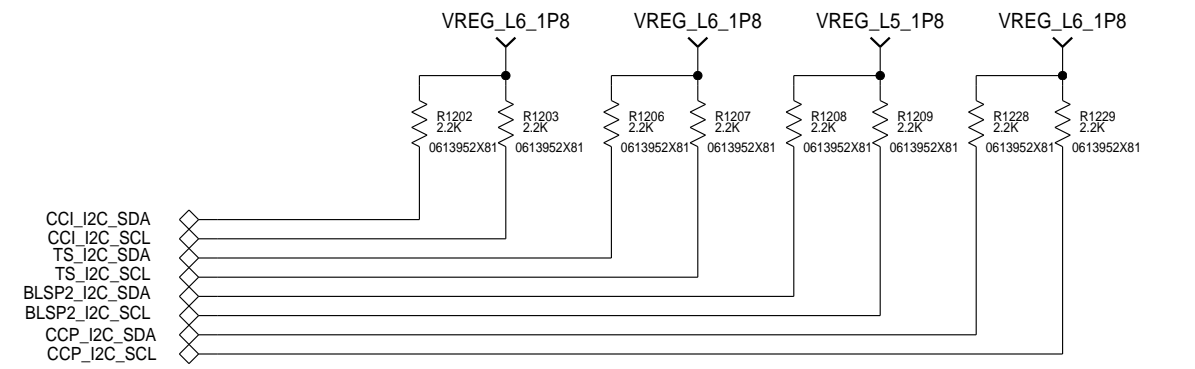

MOT BOARD ID

FOR RUNTIME REVISION INFORMATION, REFER TO:
<https://sites.google.com/a/motorola.com/runtime-product-ids>

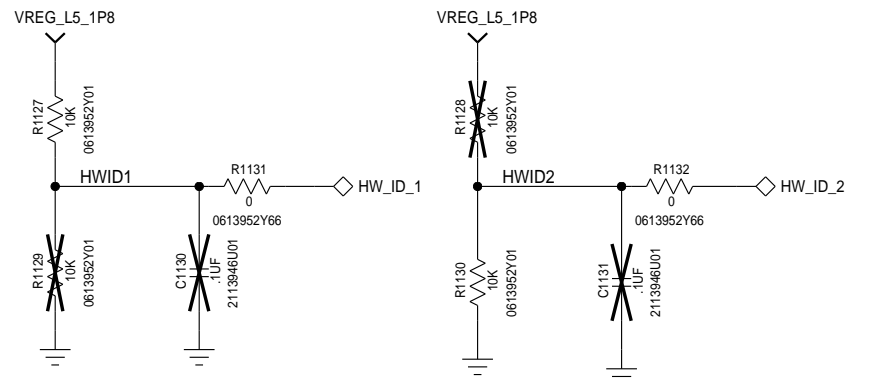

APPROVALS

ENGINEER:
LAST MODIFIED BY: FAN021
Thu Jun 02 11:51:16 2016



BLOCK TITLE:

ap_pmic

MOTOROLA CONFIDENTIAL RESTRICTED

THE DRAWING ON THIS PRINT AND INFORMATION
THEREWITH ARE PROPRIETARY TO MOTOROLA AND
SHALL NOT BE USED OR DISCUSSED IN WHOLE
OR IN PART WITHOUT MOTOROLA'S CONSENT.
© COPYRIGHT, MOTOROLA. THIS DOES
NOT IMPLY PUBLICATION

PROJECT NAME

84016562001_a.cpm

REV

01

CAD FILE NAME:

MSM: PWR1

REF 1300-1399

CAD NOTE: PLACE ONE DECAP NEAR PINS V5, V6 AND THE OTHER DECAP NEAR PIN R5

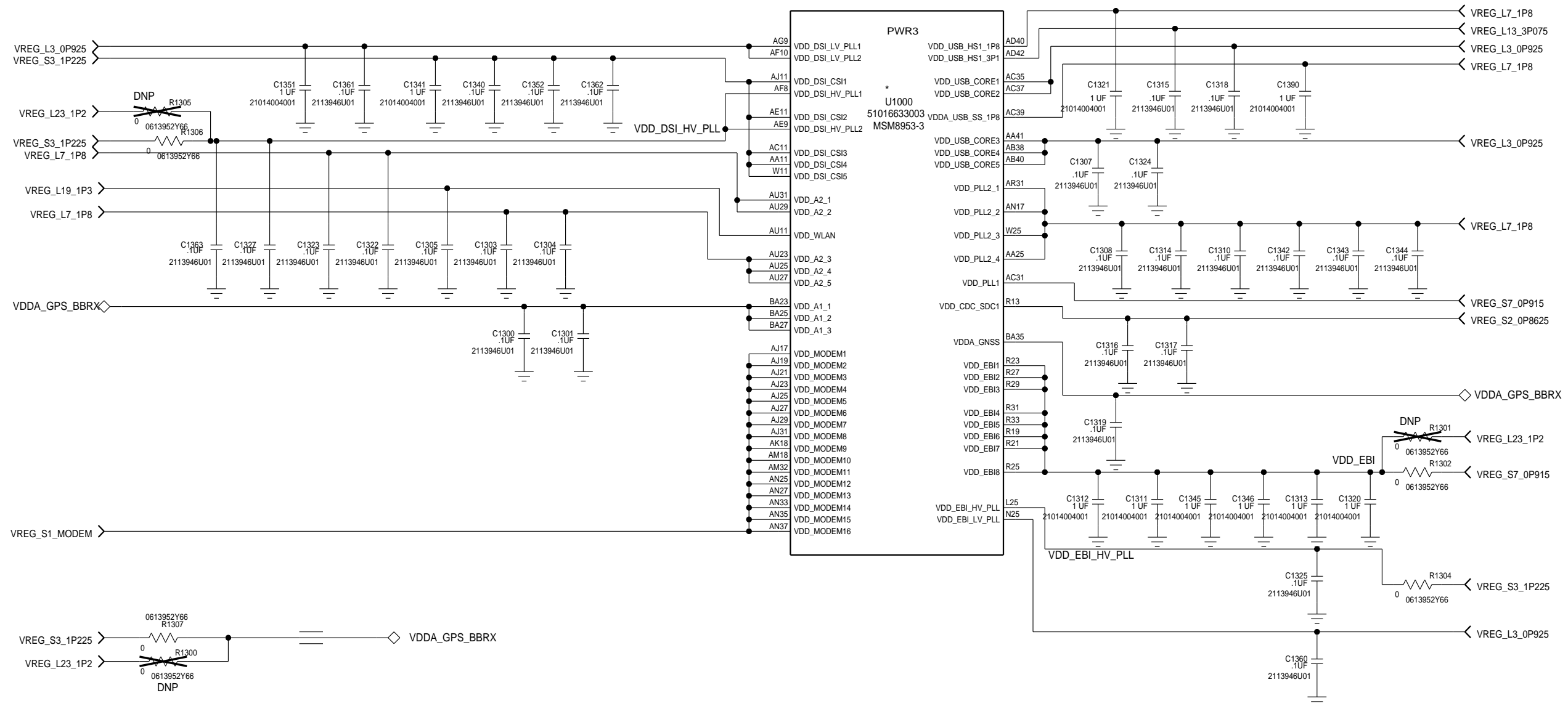

APPROVALS		MOTOROLA MOBILE DEVICES	
ENGINEER:		BLOCK TITLE:	
LAST MODIFIED BY: FAN021 Thu May 05 16:54:31 2016		ap_pmic	
MOTOROLA CONFIDENTIAL RESTRICTED <small>THE DRAWING ON THIS PRINT AND INFORMATION THEREWITH ARE PROPRIETARY TO MOTOROLA AND SHALL NOT BE USED OR DISCUSSED IN WHOLE OR IN PART WITHOUT MOTOROLA'S CONSENT. © COPYRIGHT, MOTOROLA. THIS DOES NOT IMPLY PUBLICATION</small>		PROJECT NAME B 84016562001_a.cpm	REV 01
		CAD FILE NAME:	
		PAGE 27 OF 61	

MSM: PWR2

REF 1300-1399

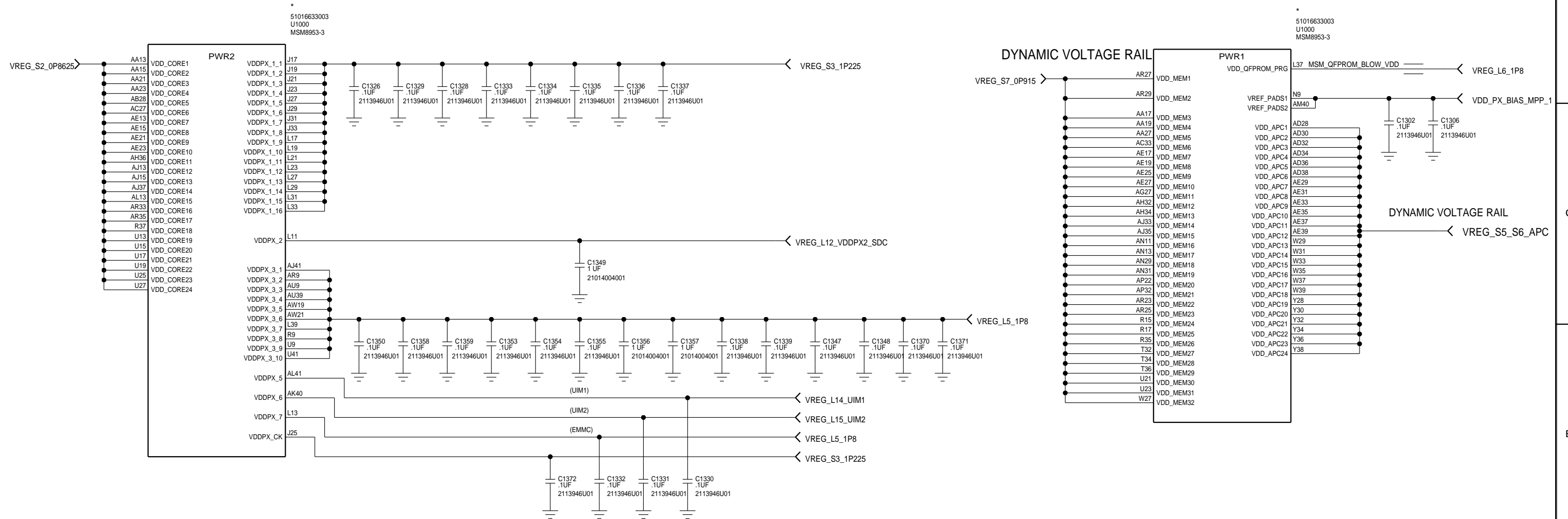

APPROVALS		MOTOROLA MOBILE DEVICES	
ENGINEER:		BLOCK TITLE:	
LAST MODIFIED BY: FAN021 Thu May 05 16:54:32 2016		ap_pmic	
MOTOROLA CONFIDENTIAL RESTRICTED <small>THE DRAWING ON THIS PRINT AND INFORMATION THEREWITH ARE PROPRIETARY TO MOTOROLA AND SHALL NOT BE USED OR DISCUSSED IN WHOLE OR IN PART WITHOUT MOTOROLA'S CONSENT. © COPYRIGHT, MOTOROLA. THIS DOES NOT IMPLY PUBLICATION</small>		PROJECT NAME B 84016562001_a.cpm	REV 01
		CAD FILE NAME:	PAGE 28 OF 61

MSM: BYPASS CAPS

REF 1400-1499

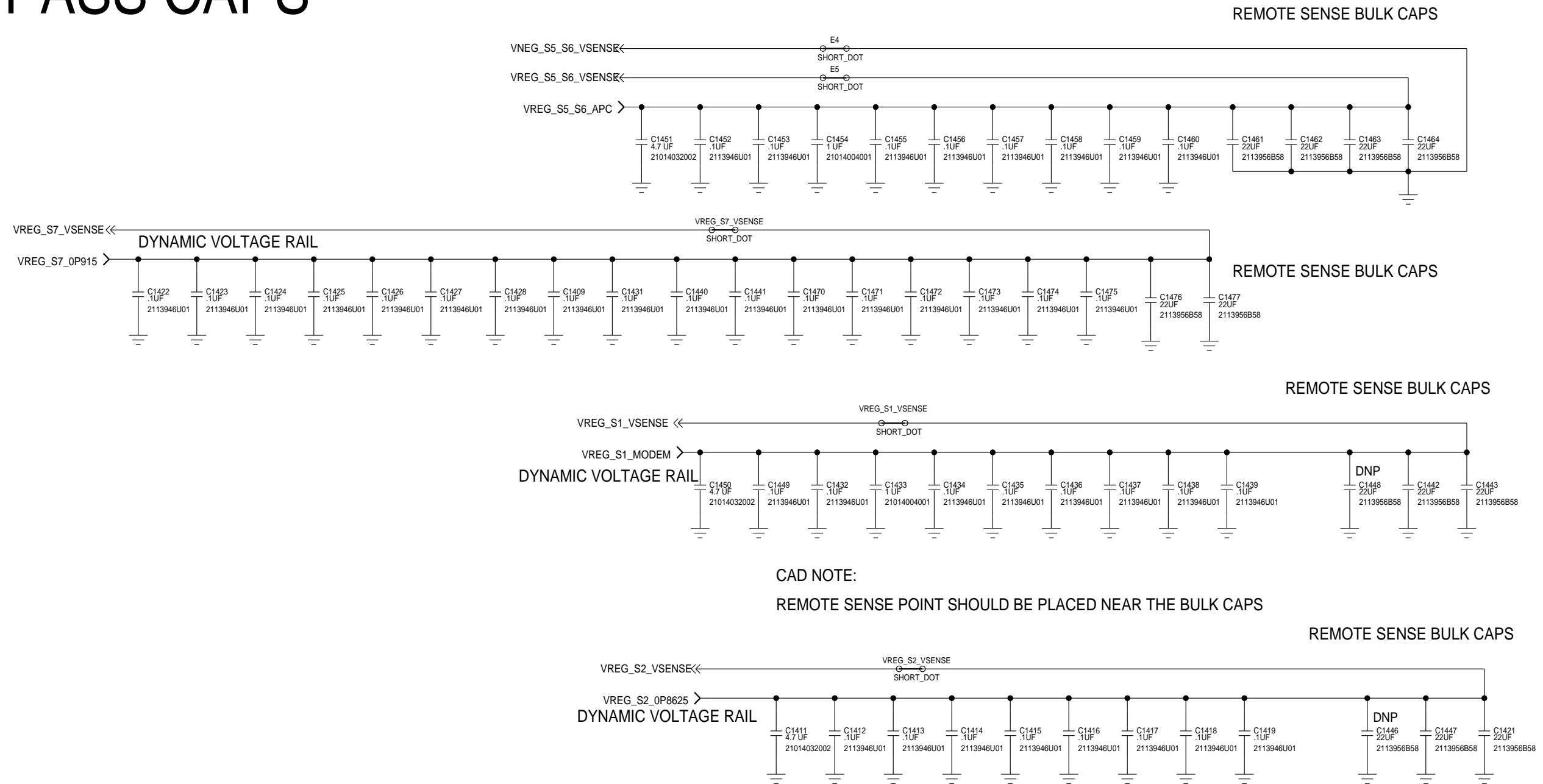

CAD NOTE:
REMOTE SENSE POINT SHOULD BE PLACED NEAR THE BULK CAPS

APPROVALS		MOTOROLA MOBILE DEVICES	
ENGINEER:		BLOCK TITLE:	
LAST MODIFIED BY: FAN021 Thu May 05 16:54:33 2016		ap_pmic	
MOTOROLA CONFIDENTIAL RESTRICTED <small>THE DRAWING ON THIS PRINT AND INFORMATION THEREWITH ARE PROPRIETARY TO MOTOROLA AND SHALL NOT BE USED OR DISCUSSED IN WHOLE OR IN PART WITHOUT MOTOROLA'S CONSENT. © COPYRIGHT, MOTOROLA. THIS DOES NOT IMPLY PUBLICATION</small>		PROJECT NAME B 84016562001_a.cpm	REV 01
		CAD FILE NAME:	PAGE 29 OF 61

MSM: GROUND/DNC

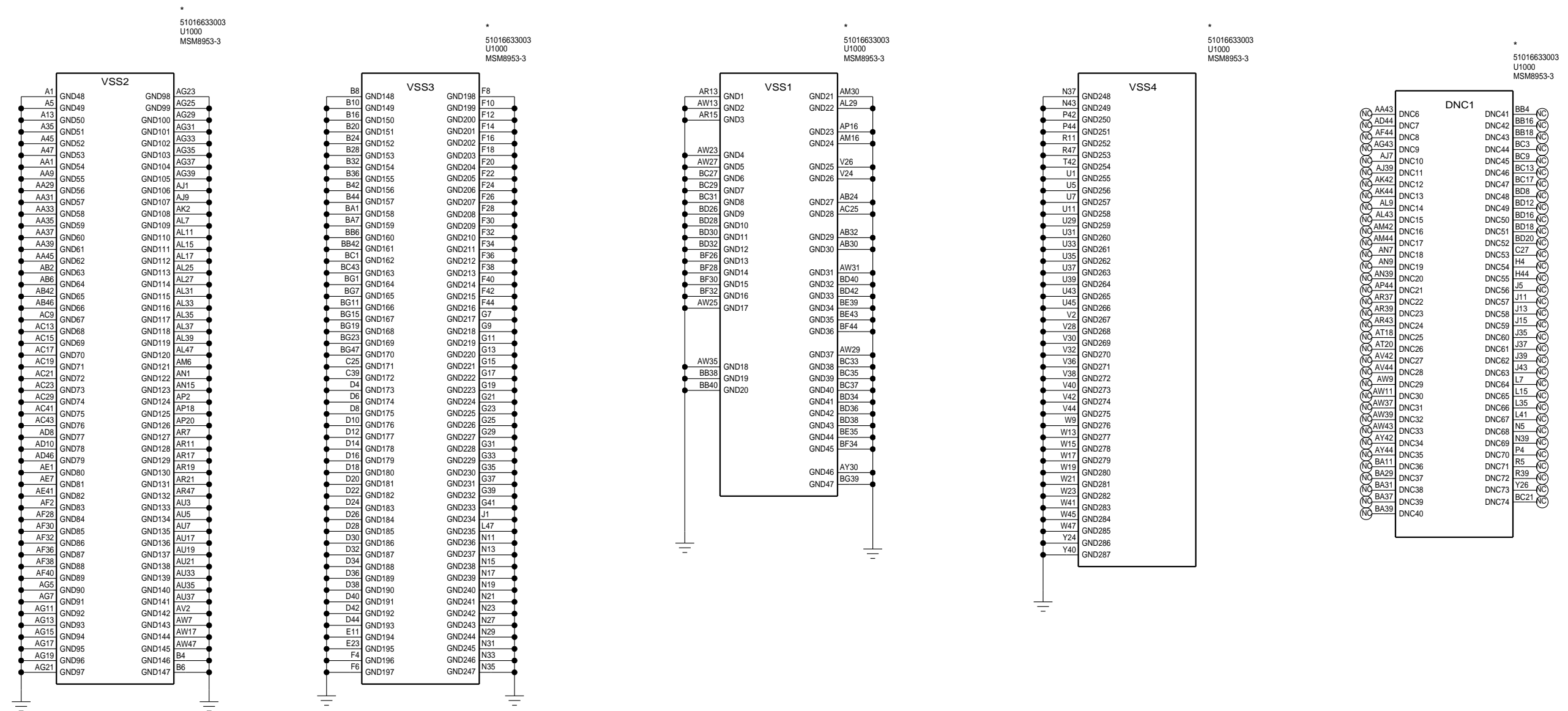

APPROVALS		MOTOROLA MOBILE DEVICES	
ENGINEER:		BLOCK TITLE:	
LAST MODIFIED BY: FAN021 Thu May 05 16:54:34 2016		ap_pmic	
MOTOROLA CONFIDENTIAL RESTRICTED <small>THE DRAWING ON THIS PRINT AND INFORMATION THEREWITH ARE PROPRIETARY TO MOTOROLA AND SHALL NOT BE USED OR DISCUSSED IN WHOLE OR IN PART WITHOUT MOTOROLA'S CONSENT. © COPYRIGHT, MOTOROLA. THIS DOES NOT IMPLY PUBLICATION</small>		PROJECT NAME B 84016562001_a.cpm	REV 01
		CAD FILE NAME:	
		PAGE 30 OF 61	

MEMORY: EMCP

REF: 1600-1699 MCP: 16GB EMMC, 2GB LPDDR3

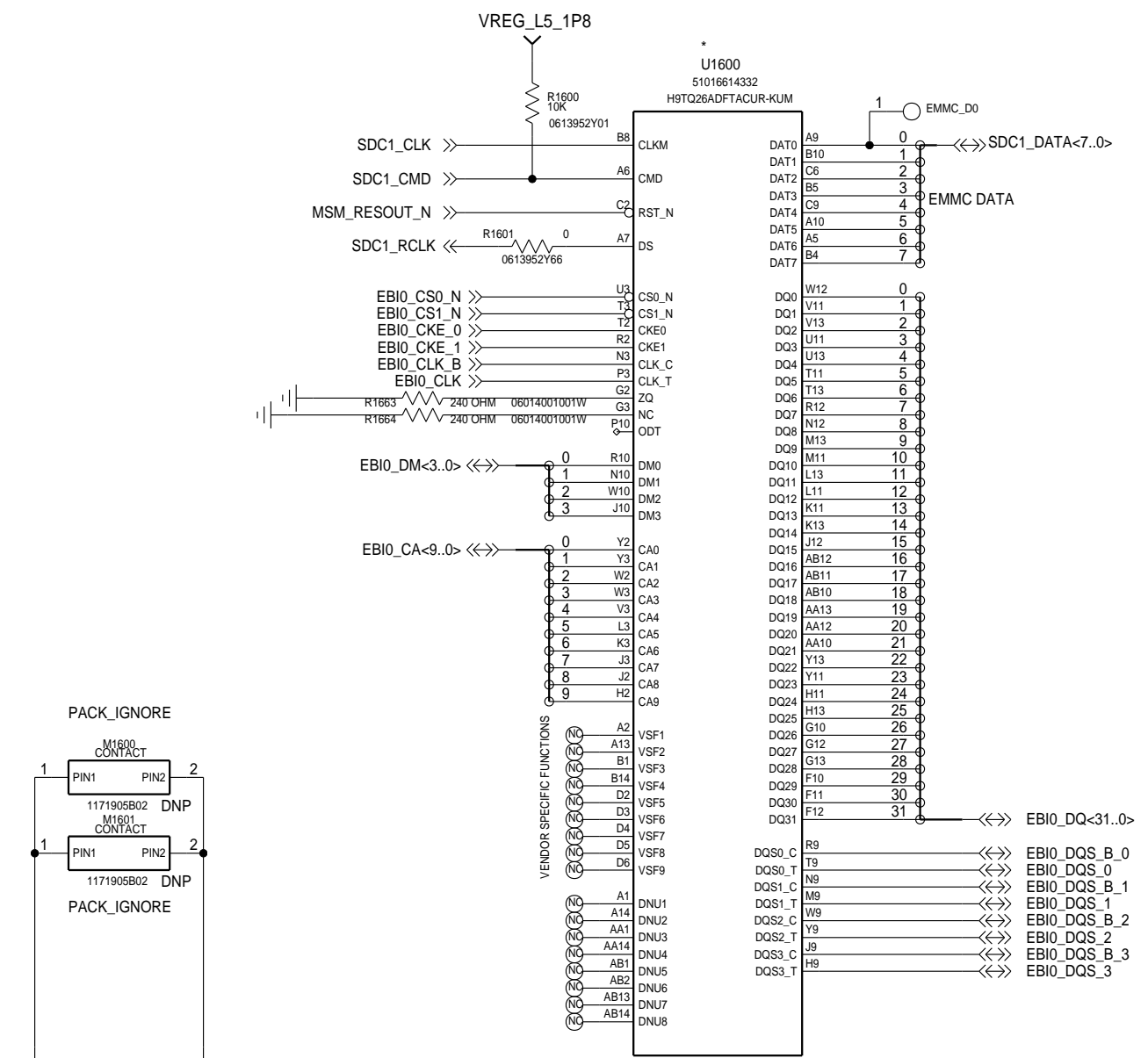
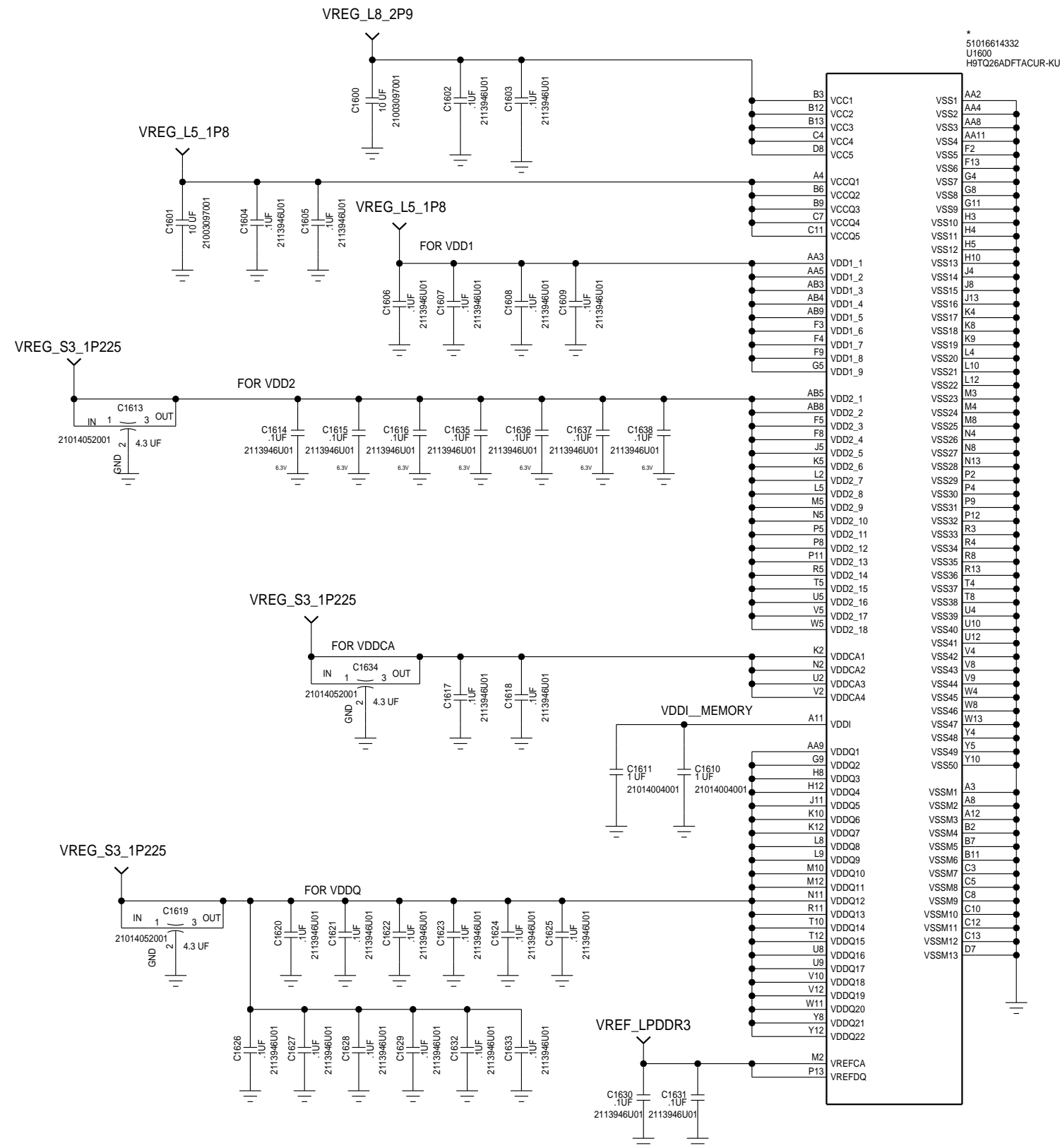

APPROVALS		MOTOROLA MOBILE DEVICES	
ENGINEER: MMI		BLOCK TITLE:	
LAST MODIFIED BY: MMI Thu May 05 16:54:35 2016		ap_pmic	
MOTOROLA CONFIDENTIAL RESTRICTED <small>THE DRAWING ON THIS PRINT AND INFORMATION THEREWITH ARE PROPRIETARY TO MOTOROLA AND SHALL NOT BE USED OR DISCUSSED IN WHOLE OR IN PART WITHOUT MOTOROLA'S CONSENT. © COPYRIGHT, MOTOROLA. THIS DOES NOT IMPLY PUBLICATION</small>		PROJECT NAME B 84016562001_a.cpm	REV 01
CAD FILE NAME:		PAGE 31 OF 61	

PM8953: HK/GHRG/LED/GPIO

REF: 2000-2099

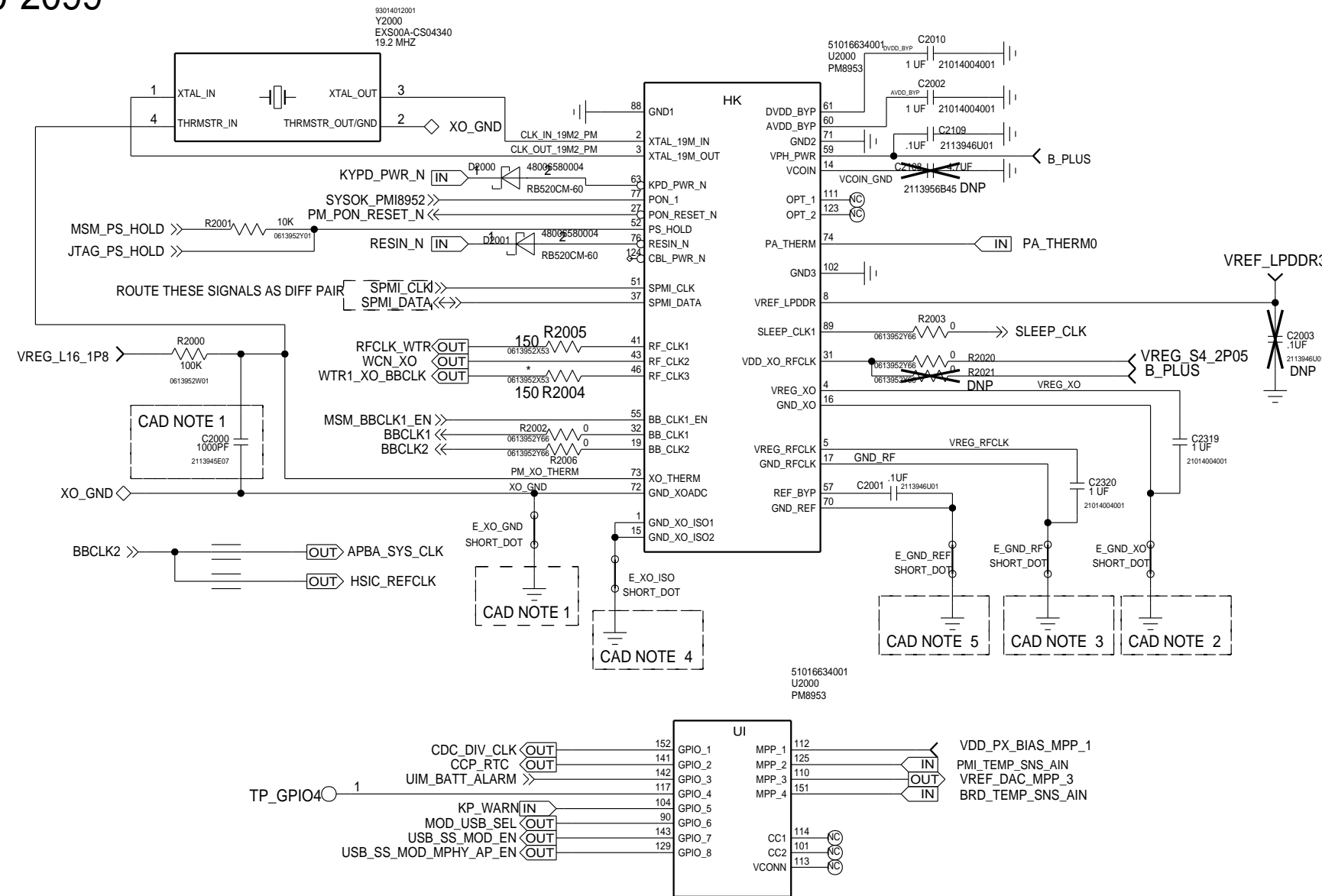

CAD NOTE 1 : PLACE C2000 CLOSER TO Y2000 AND CONNECT GND_XOADC TO CAP GND AND THEN CONNECT TO MAIN GND PLANE THROUGH DEDICATED VIA
 CAD NOTE 2 : CONNECT GND_XO TO C2319 CAP GND AND THEN CONNECT TO MAIN GND USING DEDICATED VIA.
 CAD NOTE 3 : CONNECT GND_RFCLK TO C2320 CAP GND AND THEN CONNECT TO MAIN GND PLANE USING DEDICATED VIA.
 CAD NOTE 4 : CONNECT GND_XO_ISO TO MAIN GND PLANE USING DEDICATED VIA. DO NOT SHARE THIS GND WITH OTHER GROUNDS.
 CAD NOTE 5 : CONNECT GND_REF TO CAPACITOR C2001 GND AND THEN CONNECT TO MAIN GND PLANE USING DEDICATED VIA. DON NOT SHARE THIS GND WITH OTHER GND.

APPROVALS		MOTOROLA MOBILE DEVICES	
ENGINEER: MMI		BLOCK TITLE:	
LAST MODIFIED BY: MMI Thu May 05 16:54:35 2016		ap_pmic	
MOTOROLA CONFIDENTIAL RESTRICTED <small>THE DRAWING ON THIS PRINT AND INFORMATION THEREWITH ARE PROPRIETARY TO MOTOROLA AND SHALL NOT BE USED OR DISCUSSED IN WHOLE OR IN PART WITHOUT MOTOROLA'S CONSENT. © COPYRIGHT, MOTOROLA. THIS DOES NOT IMPLY PUBLICATION</small>		PROJECT NAME B 84016562001_a.cpm	REV 01
		CAD FILE NAME:	
		PAGE 32 OF 61	

PM8953: SMPS

REF: 2200-2299

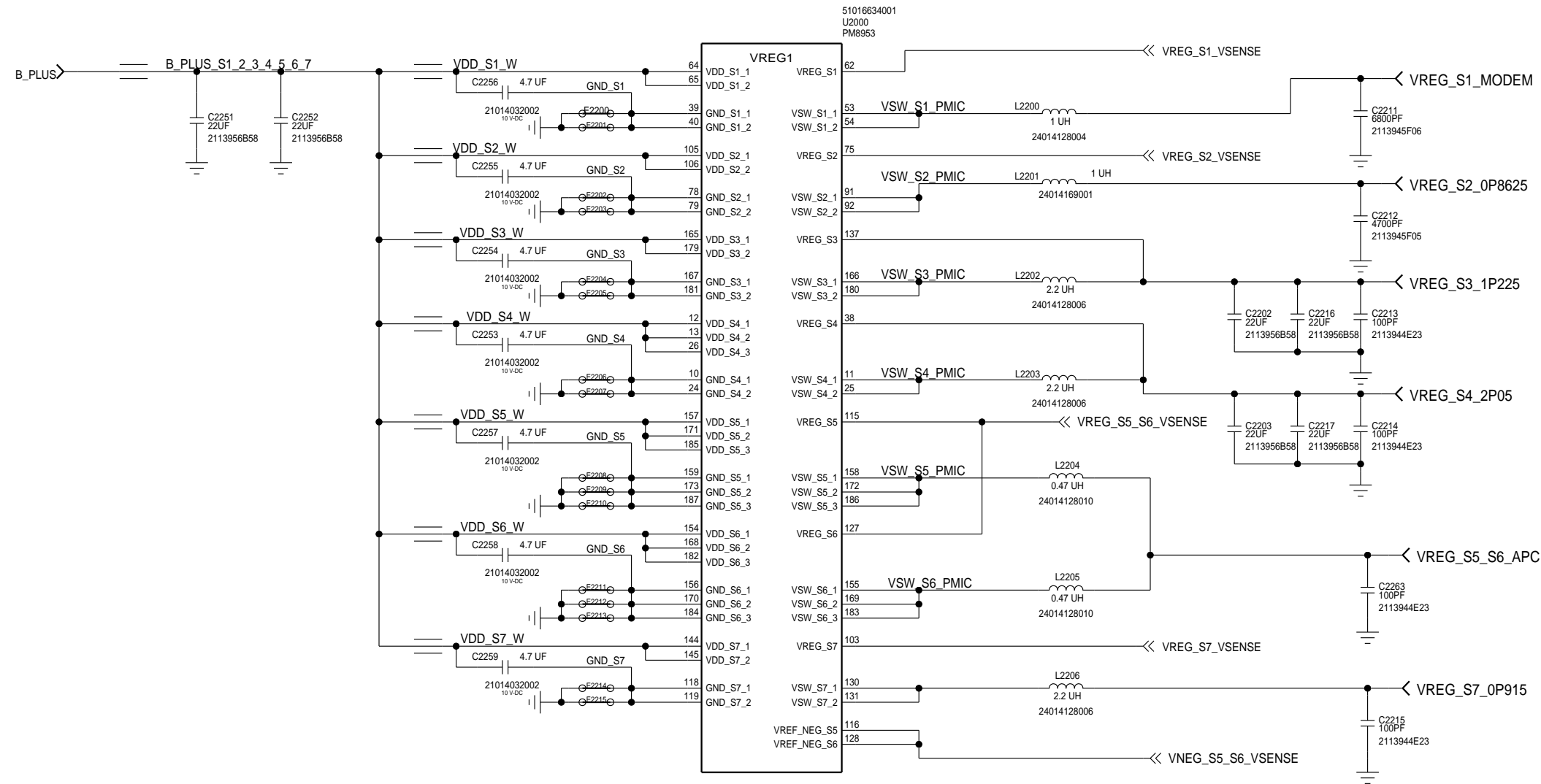

NOTE: PLACE INPUT CAPS CLOSE TO RESPECTIVE VIN PINS
EACH CAP GND SHOULD BE STAR-ROUTED

APPROVALS		MOTOROLA MOBILE DEVICES	
ENGINEER: MMI		BLOCK TITLE:	
LAST MODIFIED BY: MMI Mon Jun 20 12:00:55 2016		ap_pmic	
MOTOROLA CONFIDENTIAL RESTRICTED <small>THE DRAWING ON THIS PRINT AND INFORMATION THEREWITH ARE PROPRIETARY TO MOTOROLA AND SHALL NOT BE USED OR DISCUSSED IN WHOLE OR IN PART WITHOUT MOTOROLA'S CONSENT. © COPYRIGHT, MOTOROLA. THIS DOES NOT IMPLY PUBLICATION</small>		PROJECT NAME B 84016562001_a.cpm	REV 01
		CAD FILE NAME:	
		PAGE 33 OF 61	

PM8953: VREGS

REF: 2300-2399

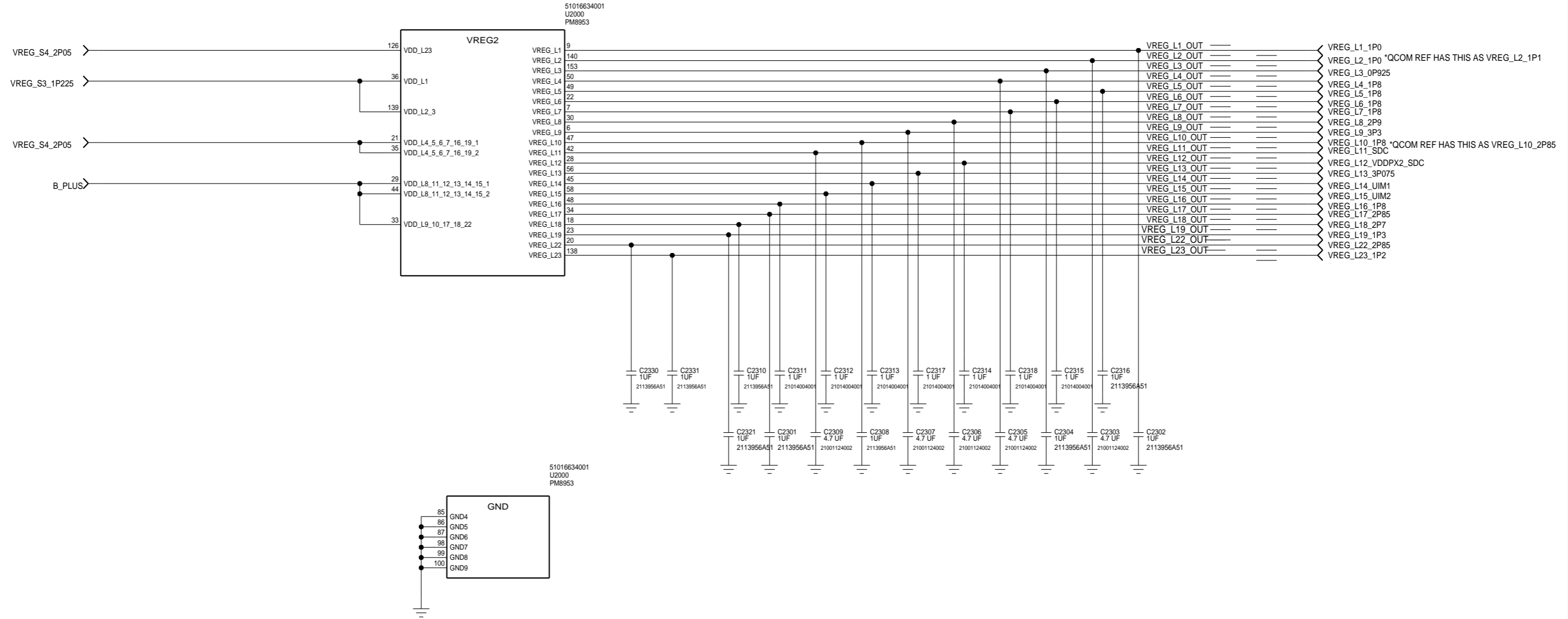

APPROVALS		 MOTOROLA MOBILE DEVICES	
ENGINEER: MMI		BLOCK TITLE:	
LAST MODIFIED BY: MMI Thu May 05 16:54:37 2016		ap_pmic	
MOTOROLA CONFIDENTIAL RESTRICTED <small>THE DRAWING ON THIS PRINT AND INFORMATION THEREWITH ARE PROPRIETARY TO MOTOROLA AND SHALL NOT BE USED OR DISCUSSED IN WHOLE OR IN PART WITHOUT MOTOROLA'S CONSENT. © COPYRIGHT, MOTOROLA. THIS DOES NOT IMPLY PUBLICATION</small>		PROJECT NAME B 84016562001_a.cpm	REV 01
		CAD FILE NAME:	
		PAGE 34 OF 61	

PMI8952: CHARGING

REF: 2400-2419

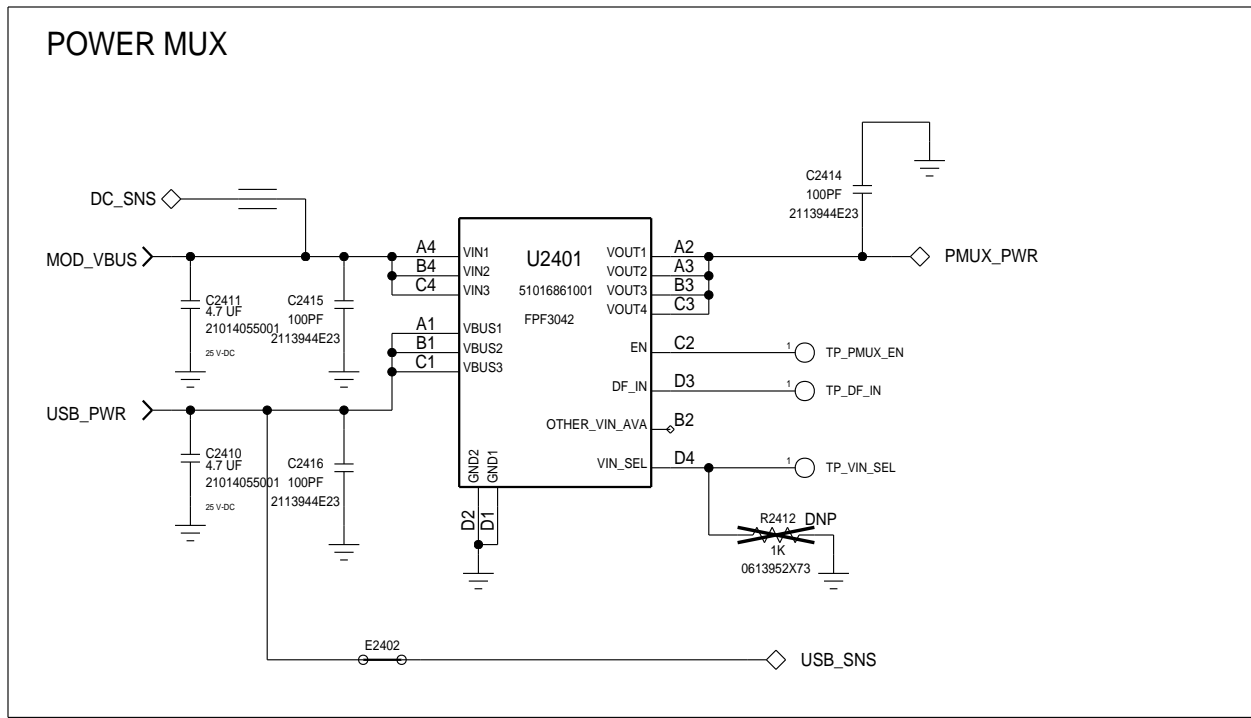
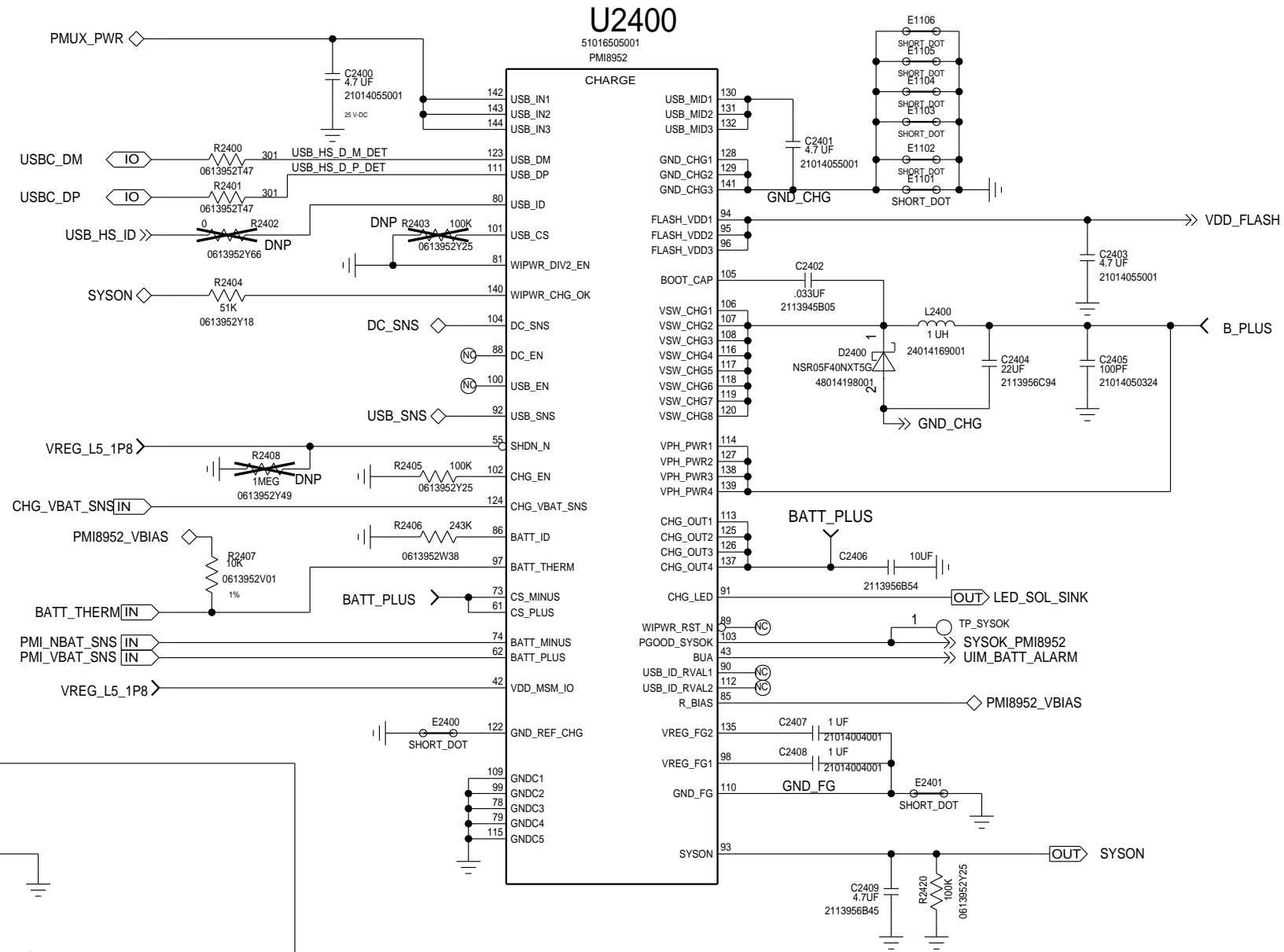

APPROVALS		MOTOROLA MOBILE DEVICES	
ENGINEER: MMI		BLOCK TITLE:	
LAST MODIFIED BY: MMI Tue May 24 16:22:49 2016		ap_pmic	
MOTOROLA CONFIDENTIAL RESTRICTED <small>THE DRAWING ON THIS PRINT AND INFORMATION THEREWITH ARE PROPRIETARY TO MOTOROLA AND SHALL NOT BE USED OR DISCUSSED IN WHOLE OR IN PART WITHOUT MOTOROLA'S CONSENT. © COPYRIGHT, MOTOROLA. THIS DOES NOT IMPLY PUBLICATION</small>		PROJECT NAME B 84016562001_a.cpm	REV 01
		CAD FILE NAME:	
		PAGE 35 OF 61	

PMI8952: IO_REF

REF: 2420-2439

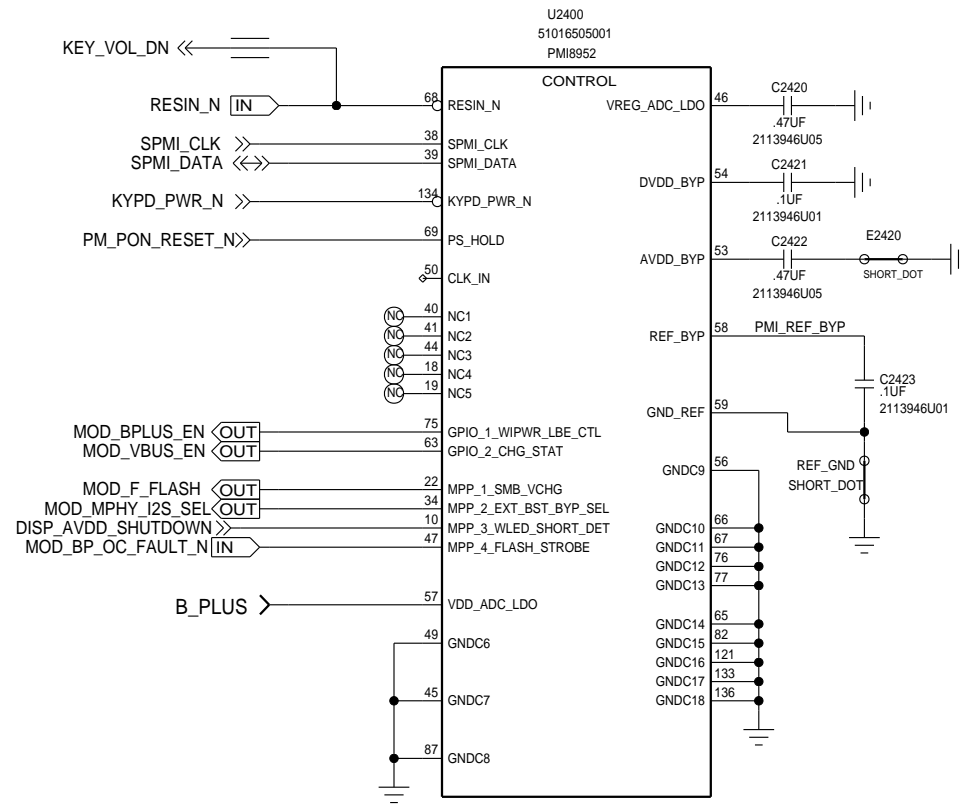

APPROVALS		MOTOROLA MOBILE DEVICES	
ENGINEER: MMI		BLOCK TITLE:	
LAST MODIFIED BY: MMI Thu May 05 16:54:38 2016		ap_pmic	
MOTOROLA CONFIDENTIAL RESTRICTED <small>THE DRAWING ON THIS PRINT AND INFORMATION THEREWITH ARE PROPRIETARY TO MOTOROLA AND SHALL NOT BE USED OR DISCUSSED IN WHOLE OR IN PART WITHOUT MOTOROLA'S CONSENT. © COPYRIGHT, MOTOROLA. THIS DOES NOT IMPLY PUBLICATION</small>		PROJECT NAME B 84016562001_a.cpm	REV 01
		CAD FILE NAME:	
		PAGE 36 OF 61	

PMI8952: REG_WLED

REF: 2440-2459

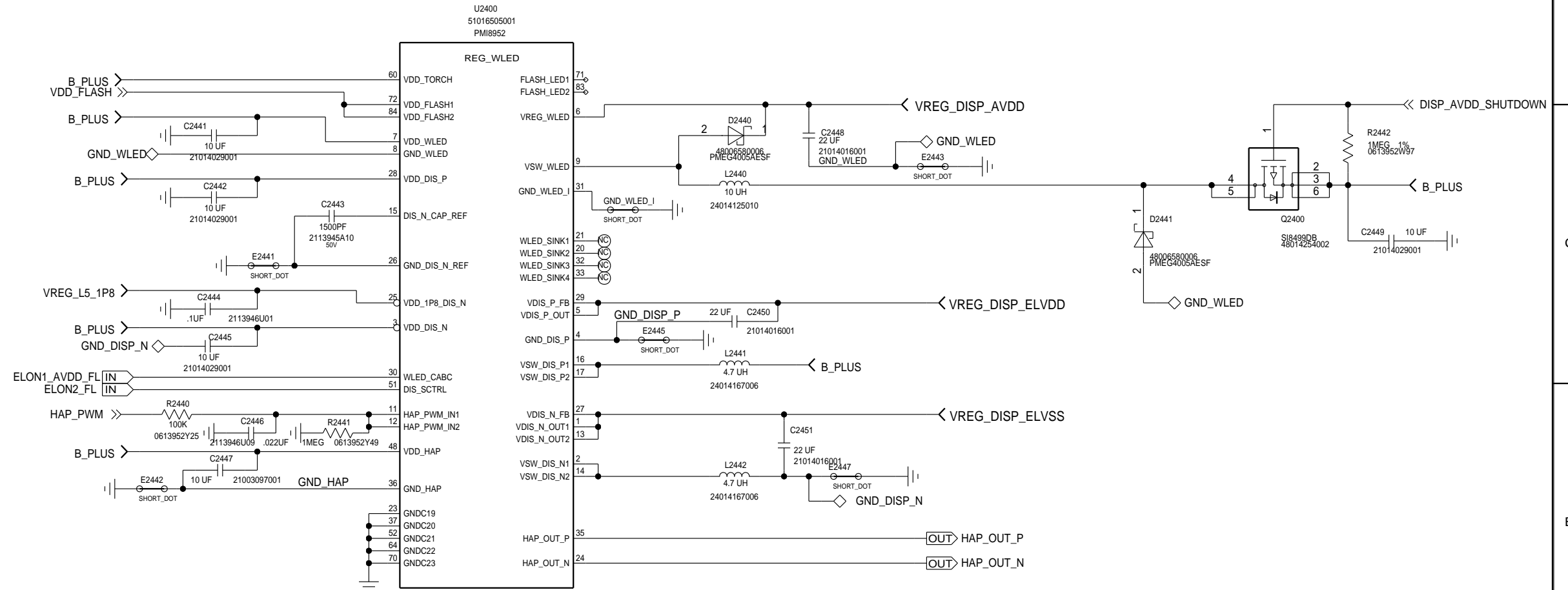

APPROVALS		MOTOROLA MOBILE DEVICES	
ENGINEER: MMI		BLOCK TITLE:	
LAST MODIFIED BY: MMI Thu May 05 16:54:39 2016		ap_pmic	
MOTOROLA CONFIDENTIAL RESTRICTED <small>THE DRAWING ON THIS PRINT AND INFORMATION THEREWITH ARE PROPRIETARY TO MOTOROLA AND SHALL NOT BE USED OR DISCUSSED IN WHOLE OR IN PART WITHOUT MOTOROLA'S CONSENT. © COPYRIGHT, MOTOROLA. THIS DOES NOT IMPLY PUBLICATION</small>		PROJECT NAME B 84016562001_a.cpm	REV 01
		CAD FILE NAME:	PAGE 37 OF 61

MSM: RF INTERFACE

REF 1200-1299

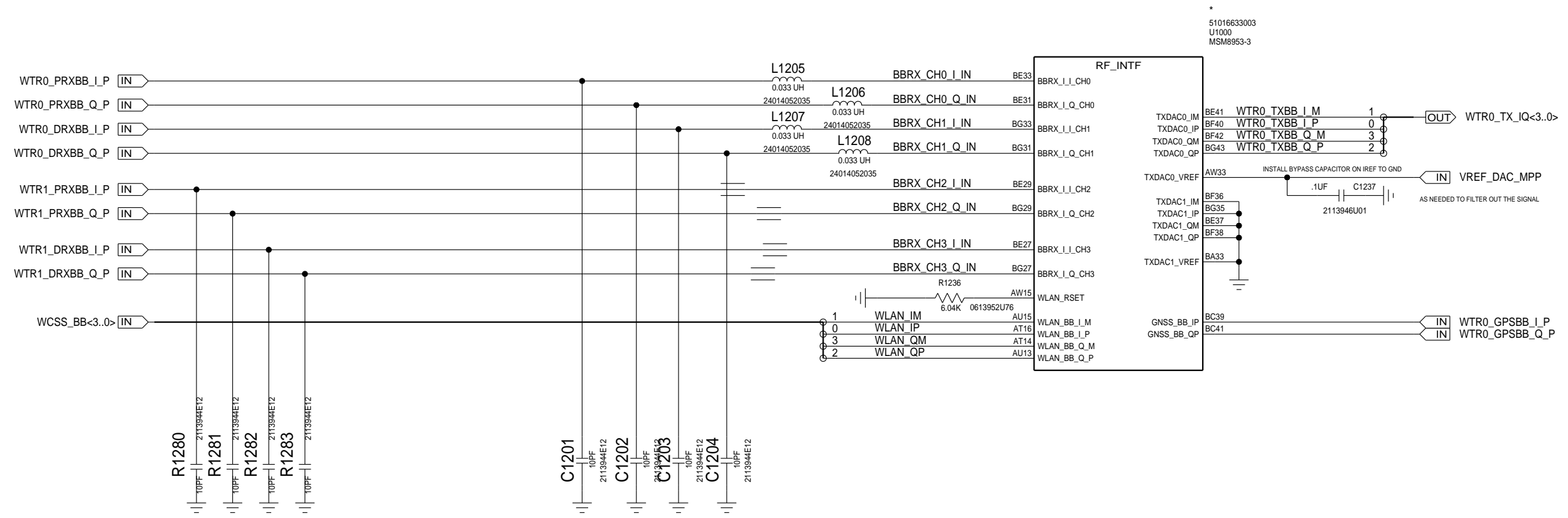

NEED TO APPLY LC FILTER FOR REDUCE B40 RX SPURS(QC 80-NP237-56)
 LC FILTER COULD BE PLACED ANYWHERE BETWEEN WTR BBRX_IQ AND MSM BBRX_IQ PINS
 BUT THE GND FOR SHUNT C SHOULD NOT BE SHARED WITH EITHER WTR OR MSM GND ON ANY LAYER.
 A DIRECT VIA FROM SHUNT C TO MAIN GND IS RECOMMENDED

APPROVALS		MOTOROLA MOBILE DEVICES	
ENGINEER:		BLOCK TITLE:	
LAST MODIFIED BY: FAN021 Thu May 05 16:54:27 2016		block_mdm9x25m_pm8019	
MOTOROLA CONFIDENTIAL RESTRICTED <small>THE DRAWING ON THIS PRINT AND INFORMATION THEREWITH ARE PROPRIETARY TO MOTOROLA AND SHALL NOT BE USED OR DISCUSSED IN WHOLE OR IN PART WITHOUT MOTOROLA'S CONSENT. © COPYRIGHT, MOTOROLA. THIS DOES NOT IMPLY PUBLICATION</small>		PROJECT NAME B 84016562001_a.cpm	REV 01
		CAD FILE NAME:	
		PAGE 38 OF 61	

CAM: POWER

REF:5500-5529

ANALOG REGULATOR 2.85V

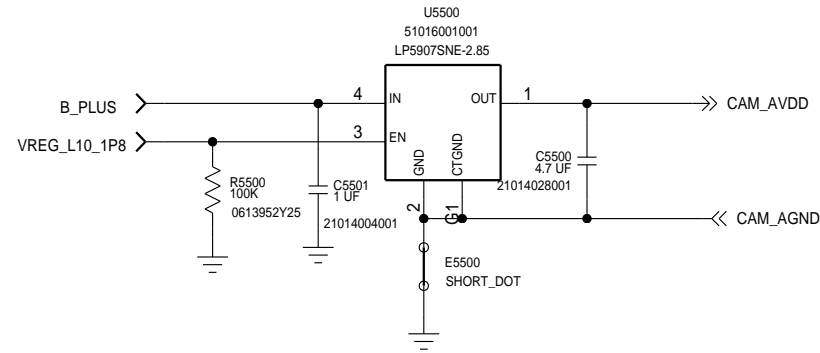

DIGITAL REGULATOR 1.2V

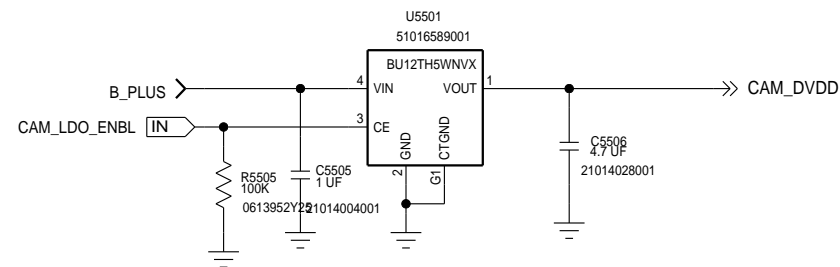

LED FLASH DRIVER FOR REAR AND FRONT IMAGERS

REF:5650-5669

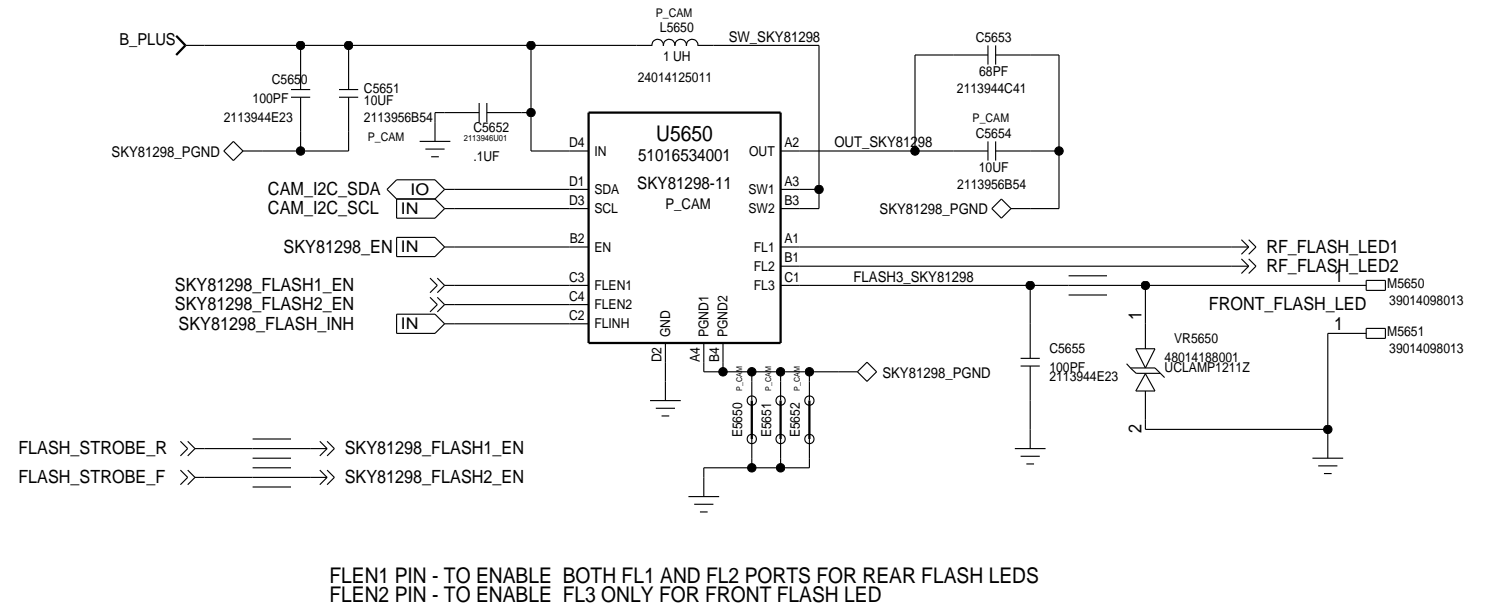

APPROVALS

ENGINEER: MMI
 LAST MODIFIED BY: MMI
 Thu May 05 16:54:21 2016

MOTOROLA CONFIDENTIAL RESTRICTED

THE DRAWING ON THIS PRINT AND INFORMATION
 THEREWITH ARE PROPRIETARY TO MOTOROLA AND
 SHALL NOT BE USED OR DISCUSSED IN WHOLE
 OR IN PART WITHOUT MOTOROLA'S CONSENT.
 © COPYRIGHT, MOTOROLA. THIS DOES
 NOT IMPLY PUBLICATION



BLOCK TITLE:
multimedia

B	PROJECT NAME	REV
	84016562001_a.cpm	01

CAD FILE NAME: _____ PAGE 39 OF 61

CAM: REAR COMMON

REF:5530-5549

D

D

C

C

B

B

A

A

APPROVALS		 MOTOROLA MOBILE DEVICES	
ENGINEER: JOHN KRAMER		BLOCK TITLE:	
LAST MODIFIED BY: AZIZ NOORI Mon Jan 04 09:46:49 2016		multimedia	
MOTOROLA CONFIDENTIAL RESTRICTED <small>THE DRAWING ON THIS PRINT AND INFORMATION THEREWITH ARE PROPRIETARY TO MOTOROLA AND SHALL NOT BE USED OR DISCUSSED IN WHOLE OR IN PART WITHOUT MOTOROLA'S CONSENT. © COPYRIGHT, MOTOROLA. THIS DOES NOT IMPLY PUBLICATION</small>		PROJECT NAME B 84016562001_a.cpm	REV 01
		CAD FILE NAME:	PAGE 40 OF 61

CAM: REAR

REF:5530-5549

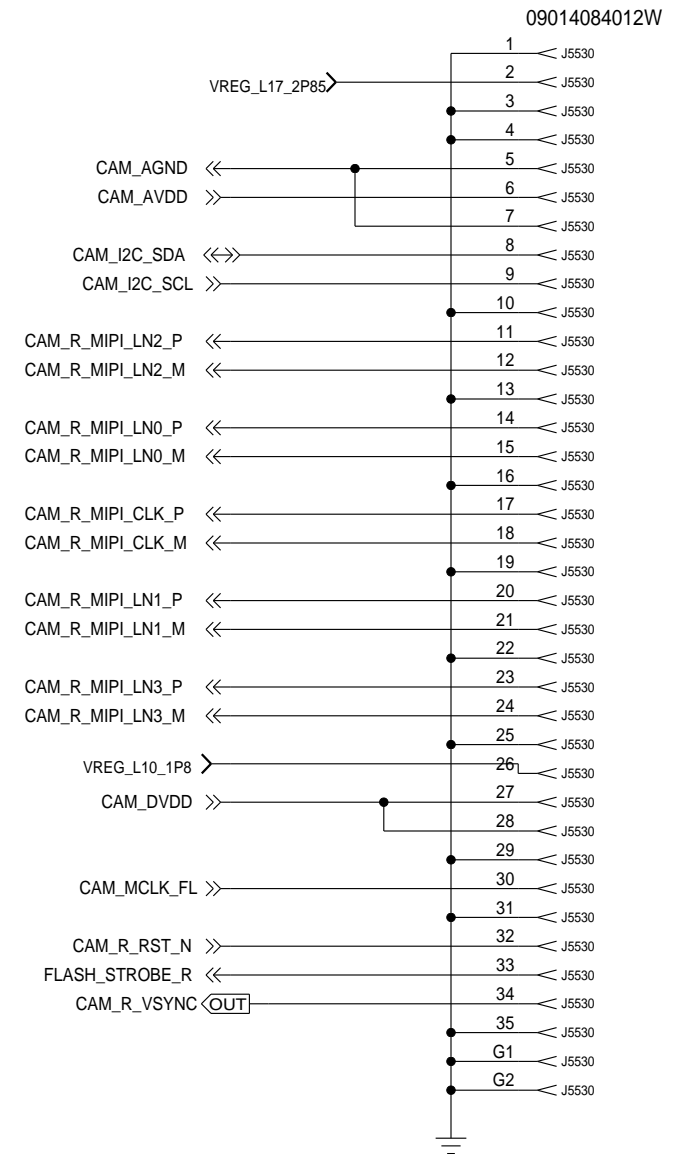
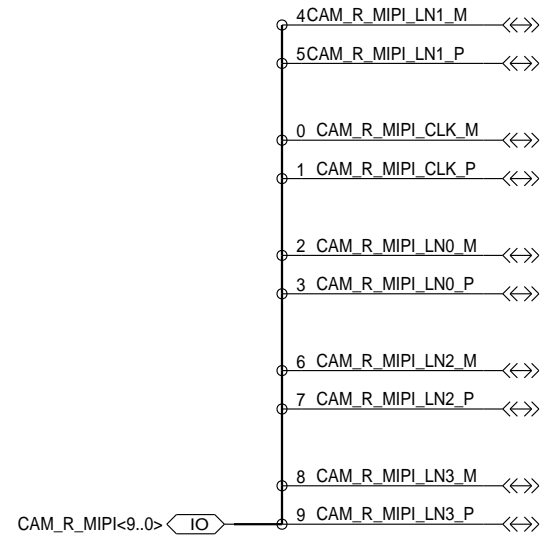
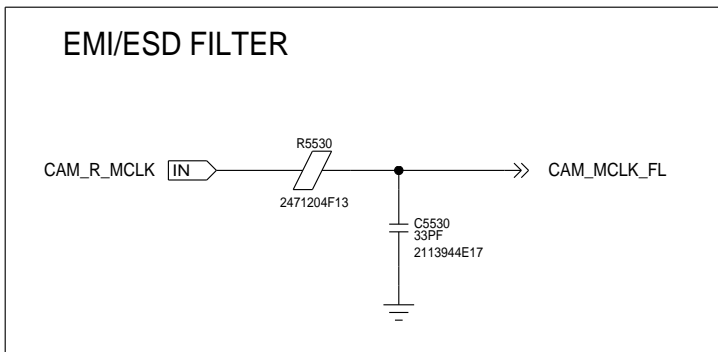
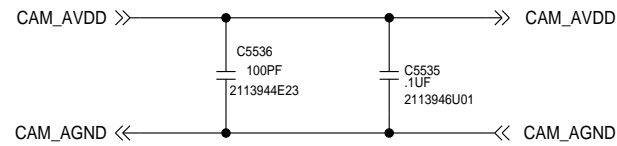
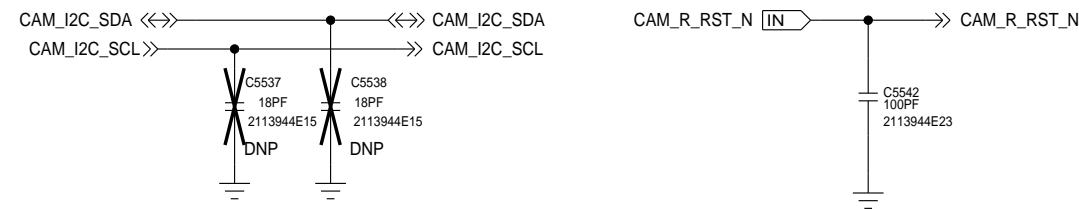
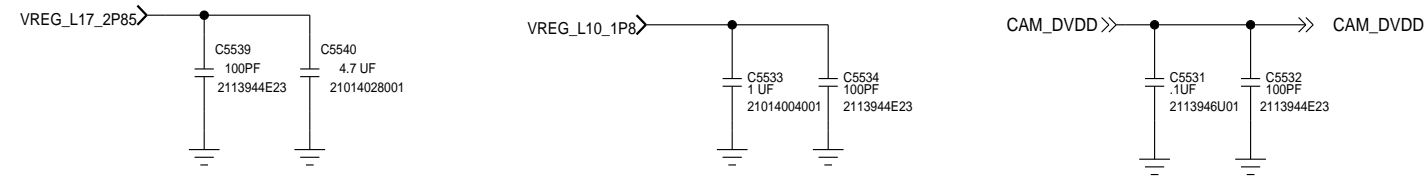

APPROVALS		MOTOROLA MOBILE DEVICES	
ENGINEER: JOHN KRAMER		BLOCK TITLE:	
LAST MODIFIED BY: AZIZ NOORI Thu May 05 16:54:22 2016		multimedia	
MOTOROLA CONFIDENTIAL RESTRICTED <small>THE DRAWING ON THIS PRINT AND INFORMATION THEREWITH ARE PROPRIETARY TO MOTOROLA AND SHALL NOT BE USED OR DISCUSSED IN WHOLE OR IN PART WITHOUT MOTOROLA'S CONSENT. © COPYRIGHT, MOTOROLA. THIS DOES NOT IMPLY PUBLICATION</small>		PROJECT NAME B 84016562001_a.cpm	REV 01
		CAD FILE NAME:	PAGE 41 OF 61

CAM: FRONT

REF 5600-5620

FF CAMERA CONNECTOR FRONT CAM I2C ADDR:

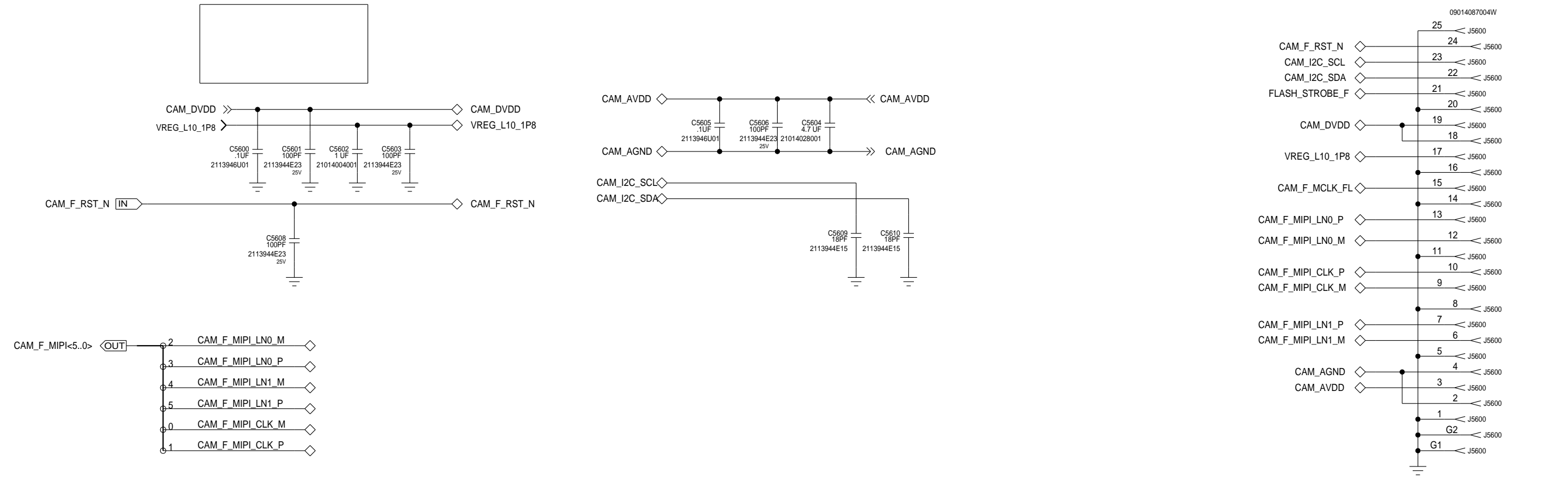

EMI/ESD FILTER

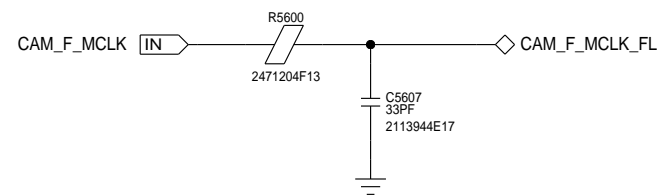

APPROVALS

ENGINEER: JOHN KRAMER

LAST MODIFIED BY: NATE CONNELL
Thu May 05 16:54:23 2016

MOTOROLA CONFIDENTIAL RESTRICTED

THE DRAWING ON THIS PRINT AND INFORMATION
THEREWITH ARE PROPRIETARY TO MOTOROLA AND
SHALL NOT BE USED OR DISCUSSED IN WHOLE
OR IN PART WITHOUT MOTOROLA'S CONSENT.
© COPYRIGHT, MOTOROLA. THIS DOES
NOT IMPLY PUBLICATION



BLOCK TITLE:

multimedia

PROJECT NAME
84016562001_a.cpm

REV
01

CAD FILE NAME:

PAGE 42 OF 61

LASER FOCUS & FLASH CONN

REF:5670-5679

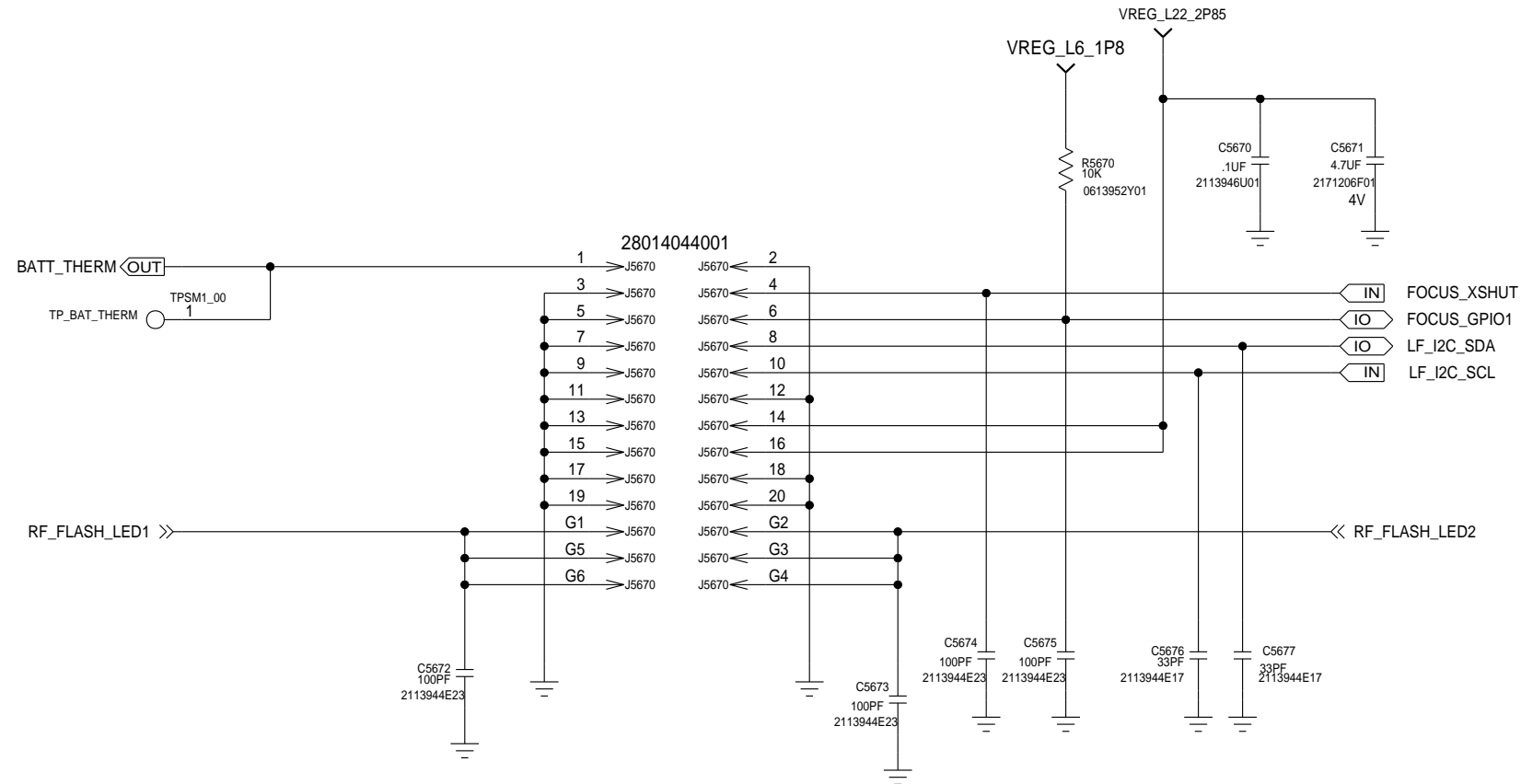

APPROVALS		MOTOROLA MOBILE DEVICES	
ENGINEER: RICH WOLNY		BLOCK TITLE:	
LAST MODIFIED BY: HUNG PHAM Thu May 05 16:54:24 2016		multimedia	
MOTOROLA CONFIDENTIAL RESTRICTED <small>THE DRAWING ON THIS PRINT AND INFORMATION THEREWITH ARE PROPRIETARY TO MOTOROLA AND SHALL NOT BE USED OR DISCUSSED IN WHOLE OR IN PART WITHOUT MOTOROLA'S CONSENT. © COPYRIGHT, MOTOROLA. THIS DOES NOT IMPLY PUBLICATION</small>		PROJECT NAME	REV
		B 84016562001_a.cpm	01
CAD FILE NAME:		PAGE 43 OF 61	

DISP: POWER

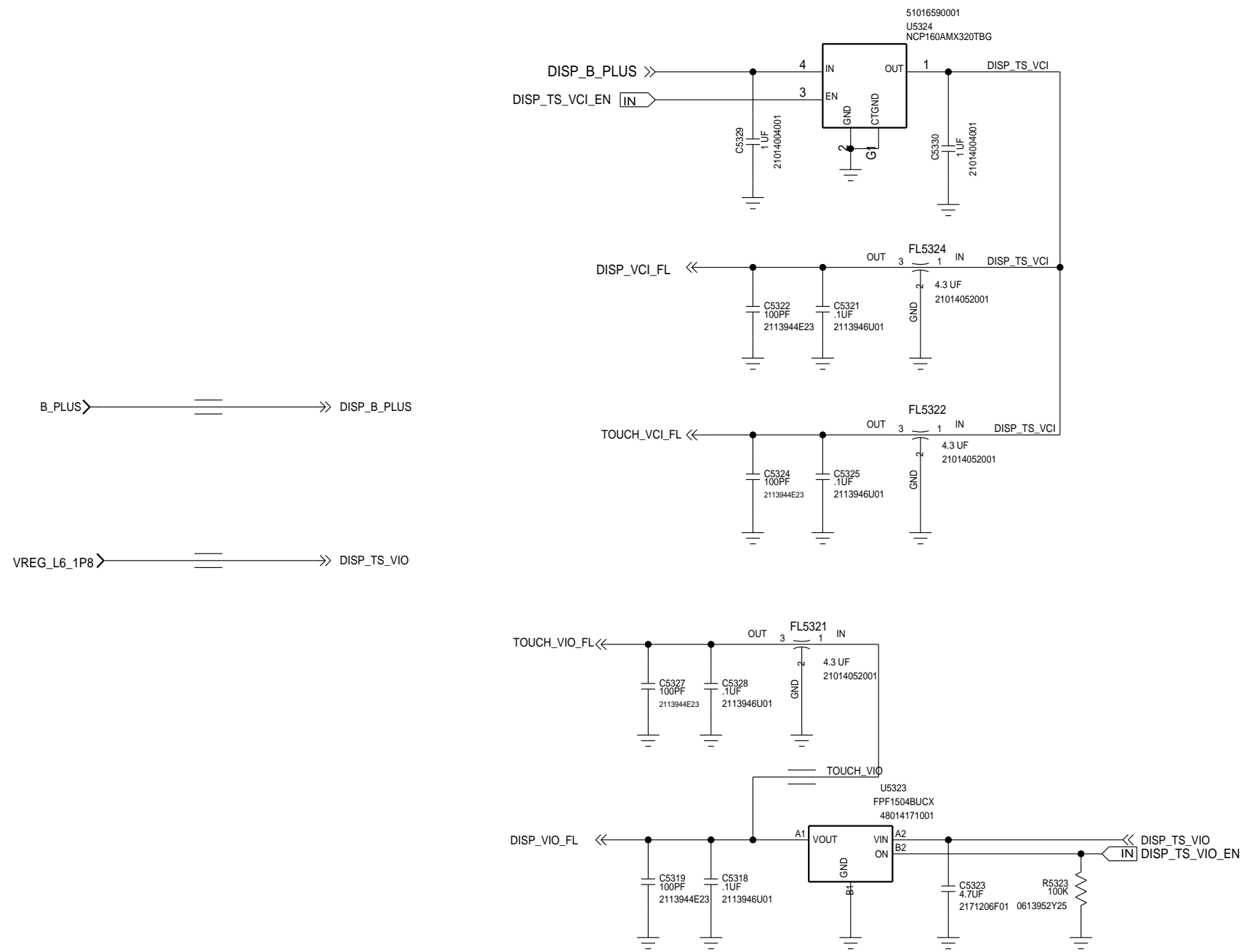

APPROVALS		MOTOROLA MOBILE DEVICES	
ENGINEER: MMI		BLOCK TITLE:	
LAST MODIFIED BY: MMI Thu May 05 16:54:25 2016		multimedia	
MOTOROLA CONFIDENTIAL RESTRICTED <small>THE DRAWING ON THIS PRINT AND INFORMATION THEREWITH ARE PROPRIETARY TO MOTOROLA AND SHALL NOT BE USED OR DISCUSSED IN WHOLE OR IN PART WITHOUT MOTOROLA'S CONSENT. © COPYRIGHT, MOTOROLA. THIS DOES NOT IMPLY PUBLICATION</small>		PROJECT NAME B 84016562001_a.cpm	REV 01
		CAD FILE NAME:	PAGE 44 OF 61

DISP: CONNECTOR

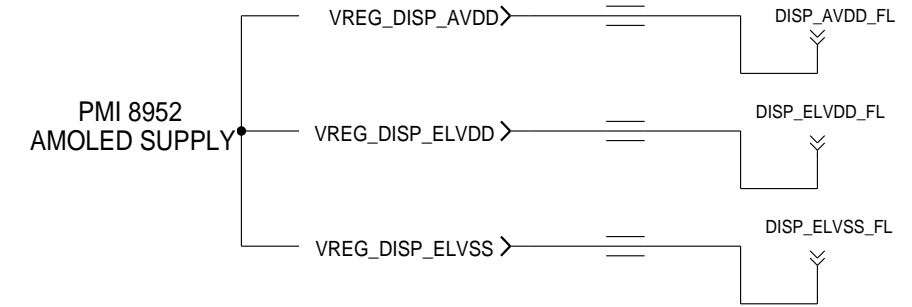
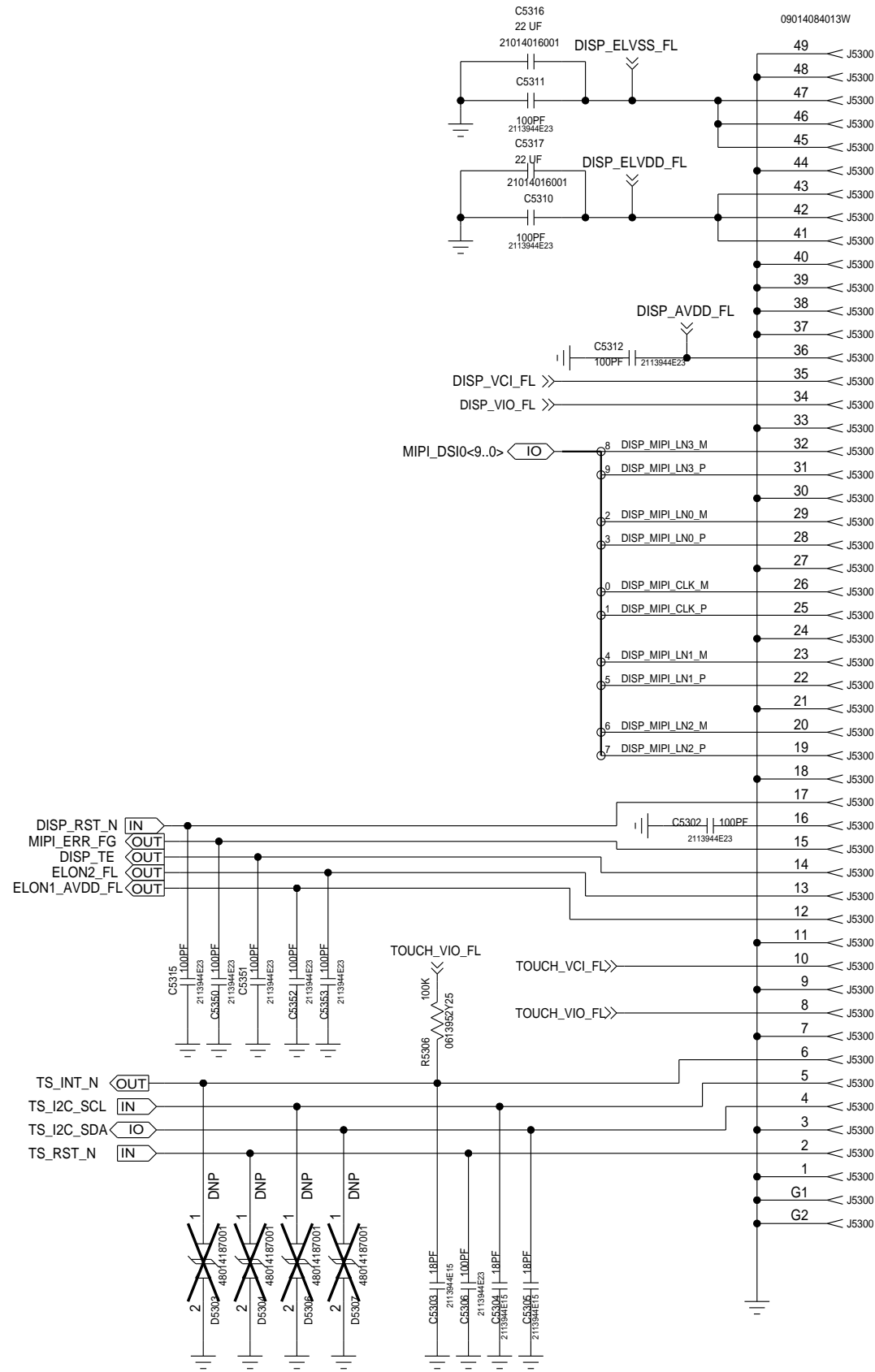

APPROVALS		MOTOROLA MOBILE DEVICES	
ENGINEER: MMI		BLOCK TITLE:	
LAST MODIFIED BY: MMI Thu May 05 16:54:26 2016		multimedia	
MOTOROLA CONFIDENTIAL RESTRICTED <small>THE DRAWING ON THIS PRINT AND INFORMATION THEREWITH ARE PROPRIETARY TO MOTOROLA AND SHALL NOT BE USED OR DISCUSSED IN WHOLE OR IN PART WITHOUT MOTOROLA'S CONSENT. © COPYRIGHT, MOTOROLA. THIS DOES NOT IMPLY PUBLICATION</small>		PROJECT NAME	REV
		B 84016562001_a.cpm	01
CAD FILE NAME:		PAGE 45 OF 61	

RFFE:TRX ASM

LAST REF NO. C7072, L7026
REF 7000-7099

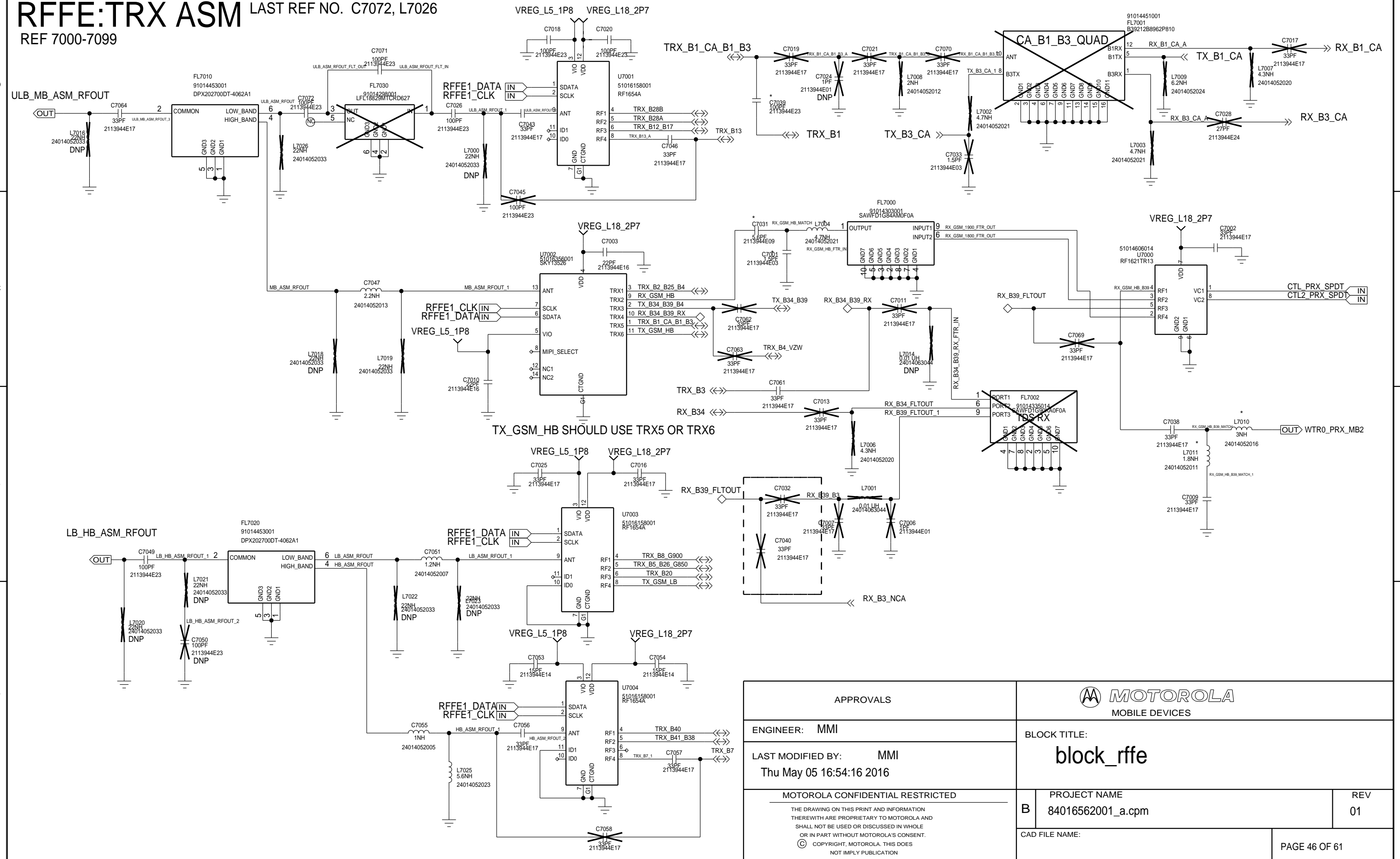

APPROVALS	
ENGINEER: MMI	
LAST MODIFIED BY: MMI Thu May 05 16:54:16 2016	
MOTOROLA CONFIDENTIAL RESTRICTED	
THE DRAWING ON THIS PRINT AND INFORMATION THEREWITH ARE PROPRIETARY TO MOTOROLA AND SHALL NOT BE USED OR DISCUSSED IN WHOLE OR IN PART WITHOUT MOTOROLA'S CONSENT. © COPYRIGHT, MOTOROLA. THIS DOES NOT IMPLY PUBLICATION	

MOTOROLA MOBILE DEVICES	
BLOCK TITLE: block_rfe	
PROJECT NAME B 84016562001_a.cpm	REV 01
CAD FILE NAME:	
PAGE 46 OF 61	

RFFE:MMMBPA LAST REF C7175, L7118, R7112

REF 7100-7299

REVISIONS			
ZONE	LTR	DESCRIPTION	DATE

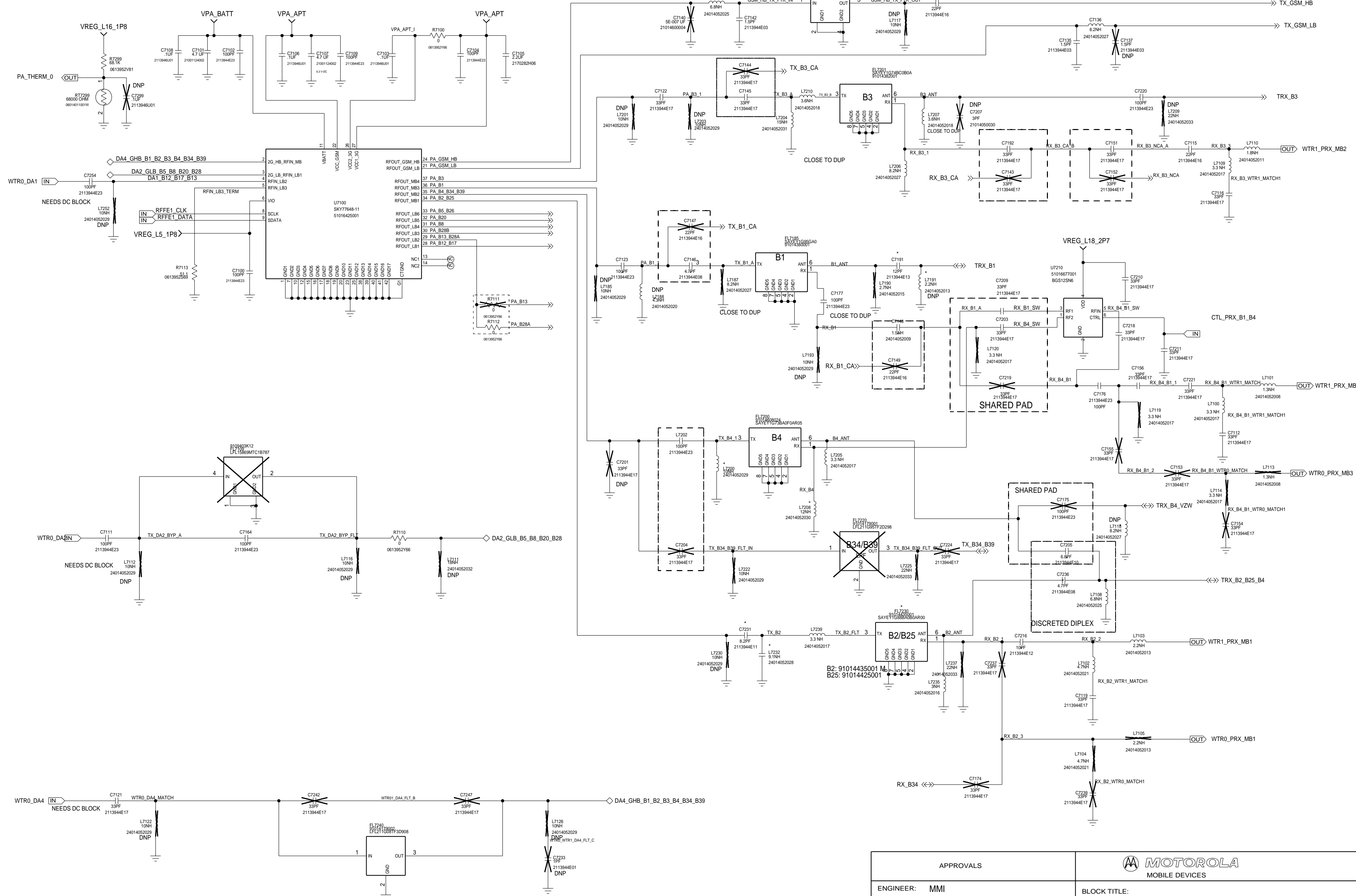

APPROVALS		MOTOROLA MOBILE DEVICES	
ENGINEER: MMI		BLOCK TITLE: block_rfe	
LAST MODIFIED BY: MMI Fri May 13 10:09:51 2016		PROJECT NAME: 84016562001_a.cpm	
MOTOROLA CONFIDENTIAL RESTRICTED		REV 01	
THE DRAWING ON THIS PRINT AND INFORMATION THEREWITH ARE PROPRIETARY TO MOTOROLA AND SHALL NOT BE USED OR DISCUSSED IN WHOLE OR IN PART WITHOUT MOTOROLA'S CONSENT. © COPYRIGHT, MOTOROLA, THIS DOES NOT IMPLY PUBLICATION		CAD FILE NAME: PAGE 47 of 61	

RFFE:HBPA
 REF 7300-7399
 LAST REF NO. C7396, L7365, R7371

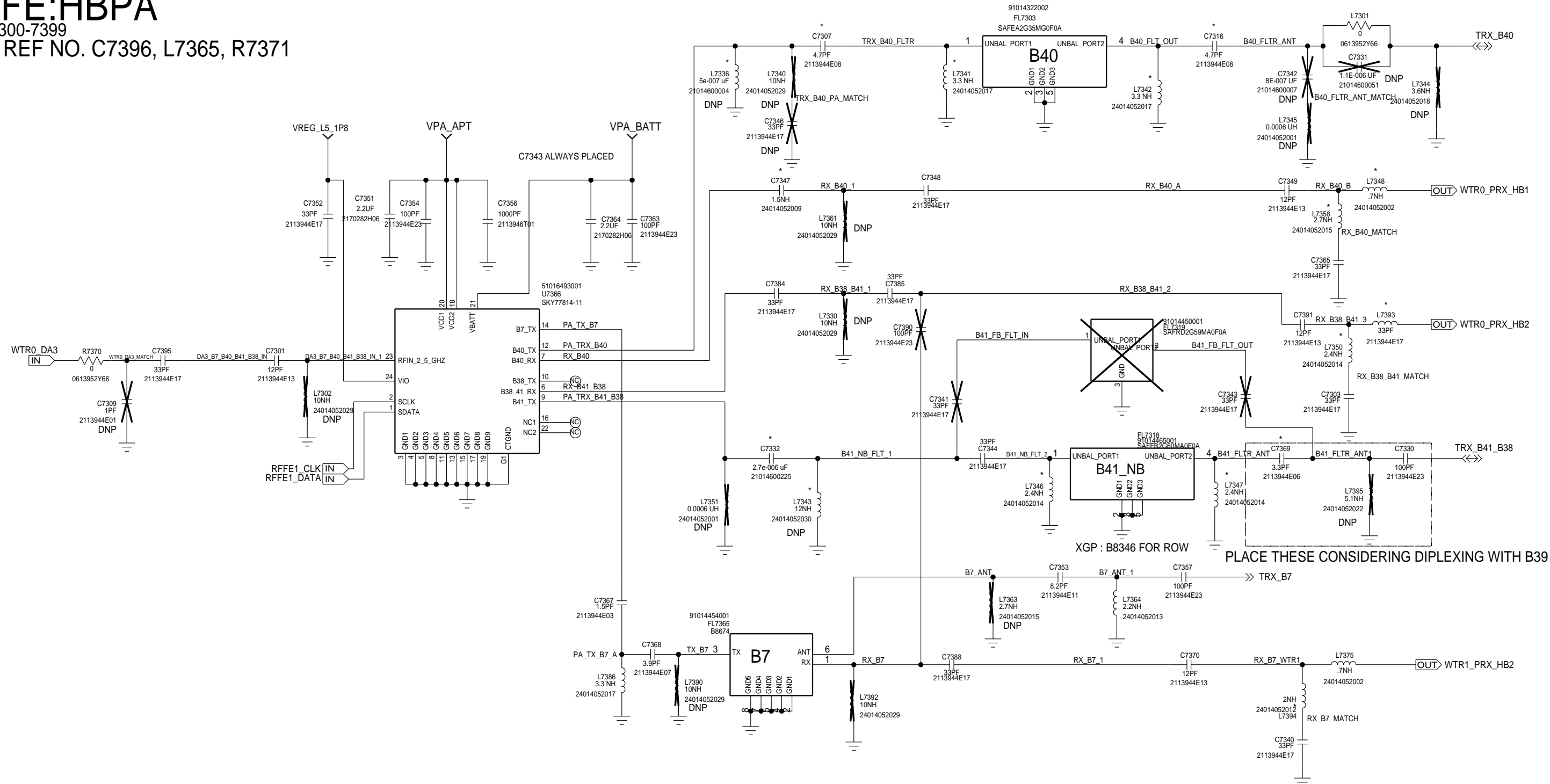

APPROVALS		MOTOROLA MOBILE DEVICES	
ENGINEER: MMI		BLOCK TITLE:	
LAST MODIFIED BY: MMI Thu May 05 16:54:17 2016		block_rfe	
MOTOROLA CONFIDENTIAL RESTRICTED <small>THE DRAWING ON THIS PRINT AND INFORMATION THEREWITH ARE PROPRIETARY TO MOTOROLA AND SHALL NOT BE USED OR DISCUSSED IN WHOLE OR IN PART WITHOUT MOTOROLA'S CONSENT. © COPYRIGHT, MOTOROLA. THIS DOES NOT IMPLY PUBLICATION</small>		PROJECT NAME	REV
		B 84016562001_a.cpm	01
CAD FILE NAME:		PAGE 48 OF 61	

RFFE:LB TRX

REF 7400-7499

LAST REF NO, C7454, L7449, R7416

D

D

C

C

B

B

A

A

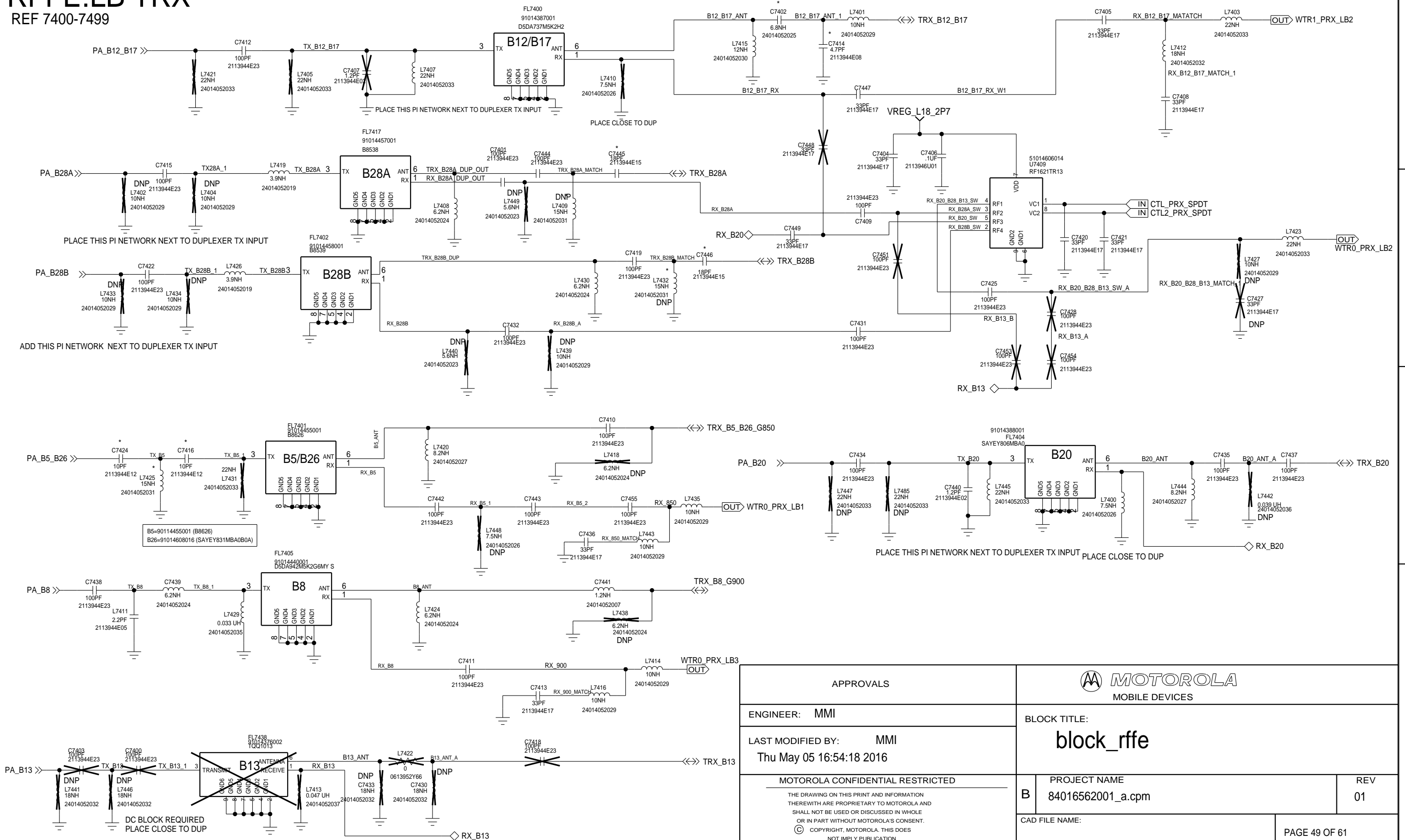

APPROVALS		MOTOROLA MOBILE DEVICES	
ENGINEER: MMI		BLOCK TITLE:	
LAST MODIFIED BY: MMI Thu May 05 16:54:18 2016		block_rfe	
MOTOROLA CONFIDENTIAL RESTRICTED		PROJECT NAME	REV
THE DRAWING ON THIS PRINT AND INFORMATION THEREWITH ARE PROPRIETARY TO MOTOROLA AND SHALL NOT BE USED OR DISCUSSED IN WHOLE OR IN PART WITHOUT MOTOROLA'S CONSENT. © COPYRIGHT, MOTOROLA. THIS DOES NOT IMPLY PUBLICATION		B 84016562001_a.cpm	01
CAD FILE NAME:		PAGE 49 OF 61	

RFFE:QFE2101
REF 7400-7499

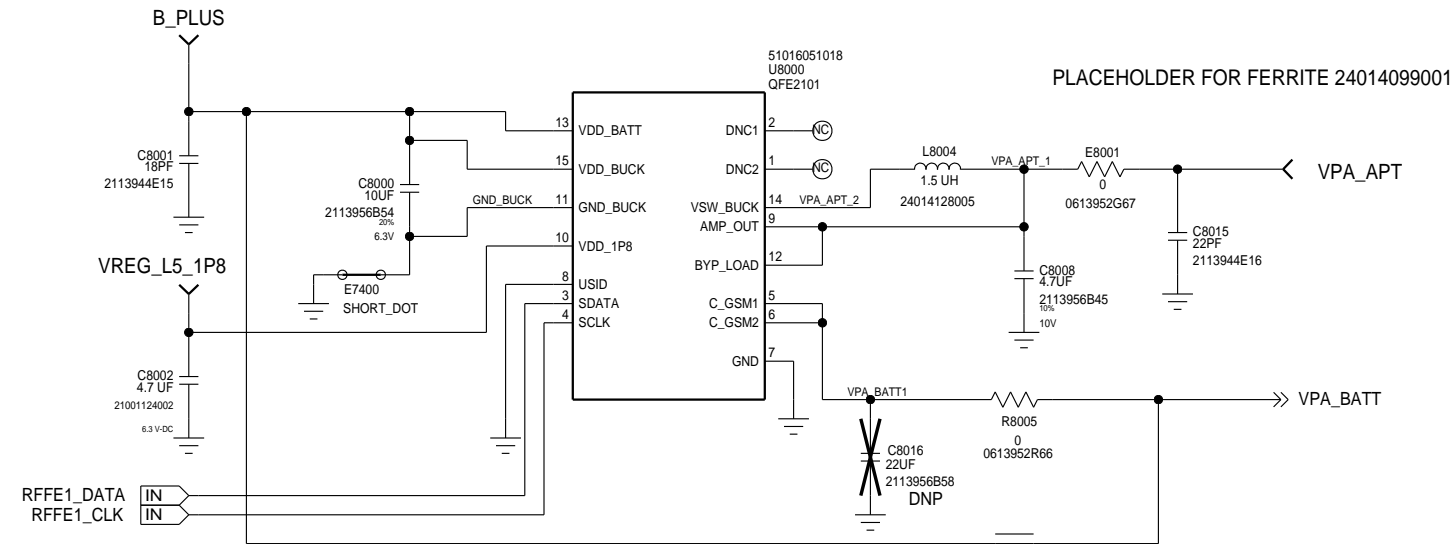

E7400 : DO NOT VIA DIRECTLY TO GROUND PLANE. KEEP ISOLATED ON SURFACE LAYER;

BYPASS OPTION FOR VPA_VBATT
DNP APPROPRIATELY

APPROVALS		MOTOROLA MOBILE DEVICES	
ENGINEER: MMI		BLOCK TITLE: block_rffe	
LAST MODIFIED BY: MMI Thu May 05 16:54:19 2016		PROJECT NAME B 84016562001_a.cpm	
MOTOROLA CONFIDENTIAL RESTRICTED <small>THE DRAWING ON THIS PRINT AND INFORMATION THEREWITH ARE PROPRIETARY TO MOTOROLA AND SHALL NOT BE USED OR DISCUSSED IN WHOLE OR IN PART WITHOUT MOTOROLA'S CONSENT. © COPYRIGHT, MOTOROLA. THIS DOES NOT IMPLY PUBLICATION</small>		REV 01	
		PAGE 50 OF 61	

RFFE: DIVERSITY

REF 7500-7649
LAST REF NO. C7627, L7566

REVISIONS

ZONE	LTR	DESCRIPTION	DATE	APPR.

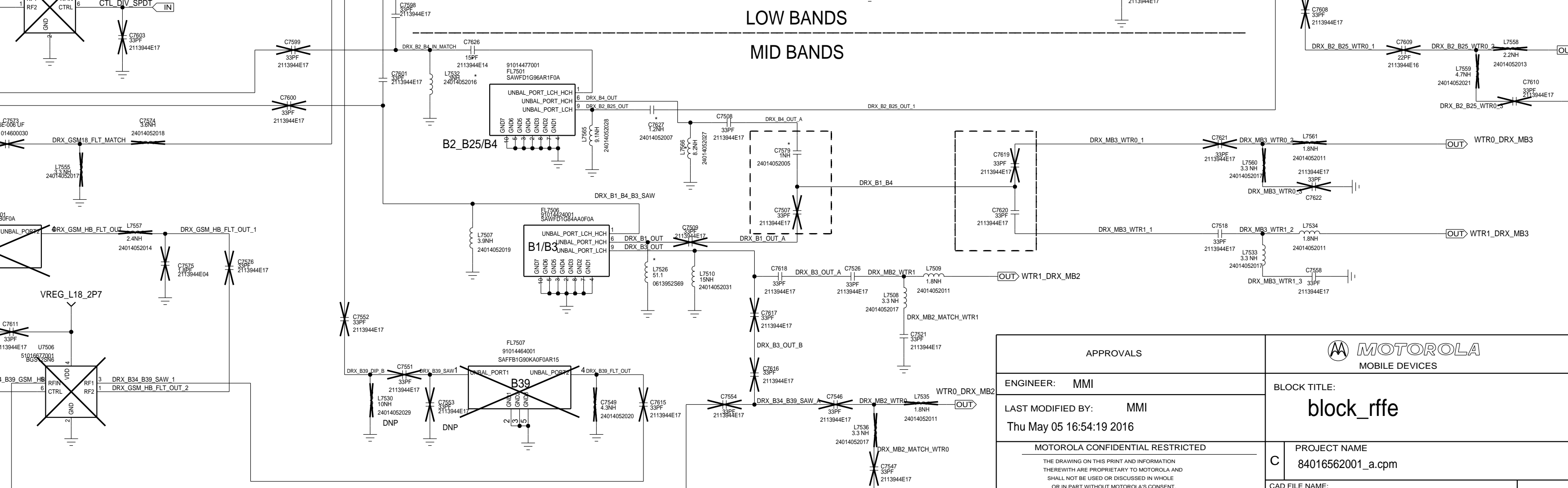
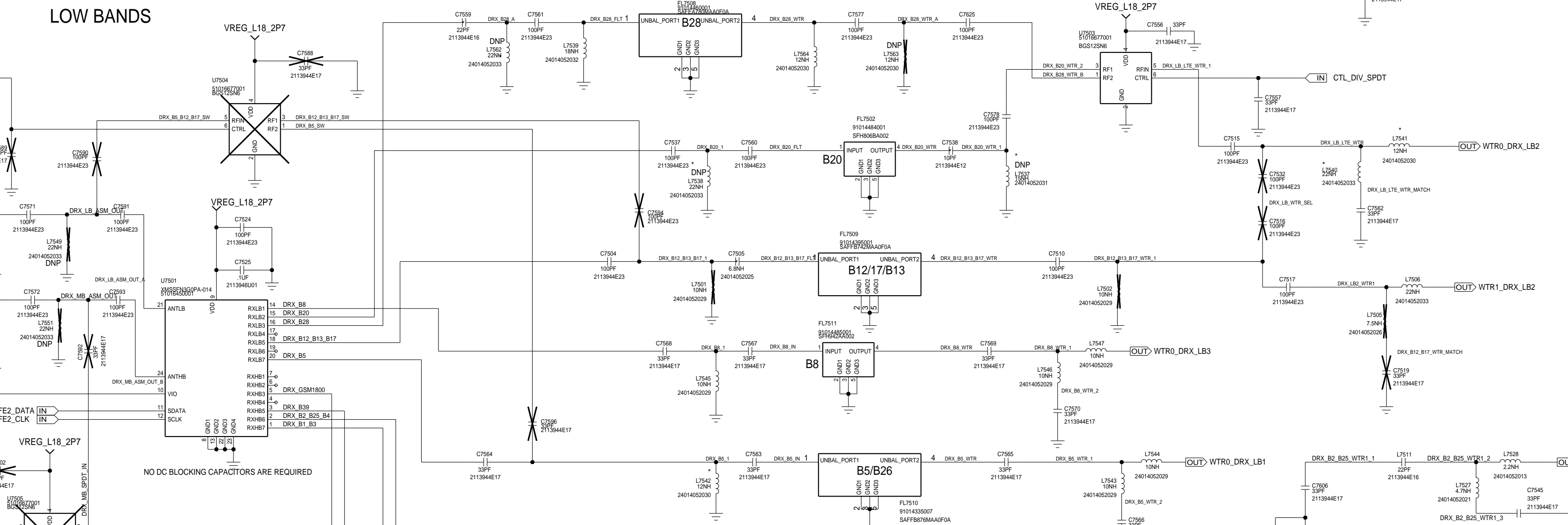
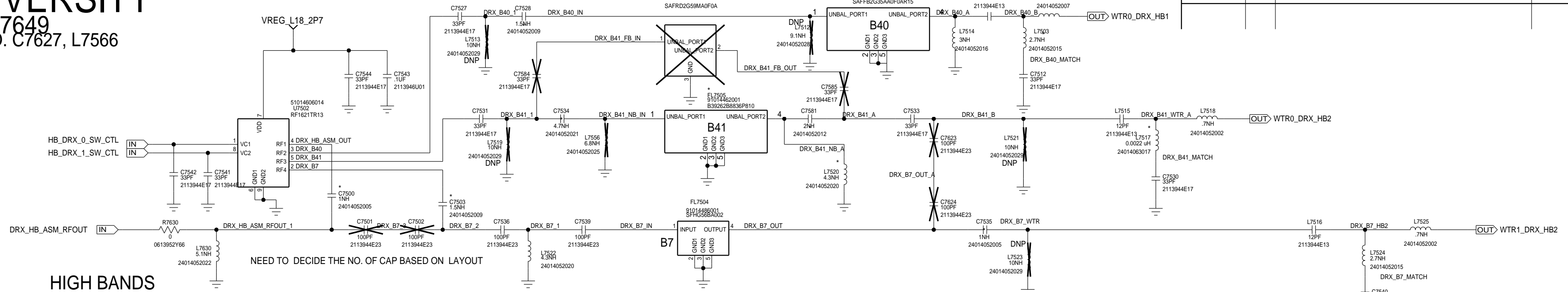

APPROVALS	
ENGINEER:	MMI
LAST MODIFIED BY:	MMI
Thu May 05 16:54:19 2016	
MOTOROLA CONFIDENTIAL RESTRICTED	
THE DRAWING ON THIS PRINT AND INFORMATION THEREWITH ARE PROPRIETARY TO MOTOROLA AND SHALL NOT BE USED OR DISCLOSED IN WHOLE OR IN PART WITHOUT MOTOROLA'S CONSENT. © COPYRIGHT, MOTOROLA. THIS DOES NOT IMPLY PUBLICATION	

BLOCK TITLE: block_rfe	
PROJECT NAME C 84016562001_a.cpm	REV 01
CAD FILE NAME:	

RFFE: GPS

REF 7650-7699

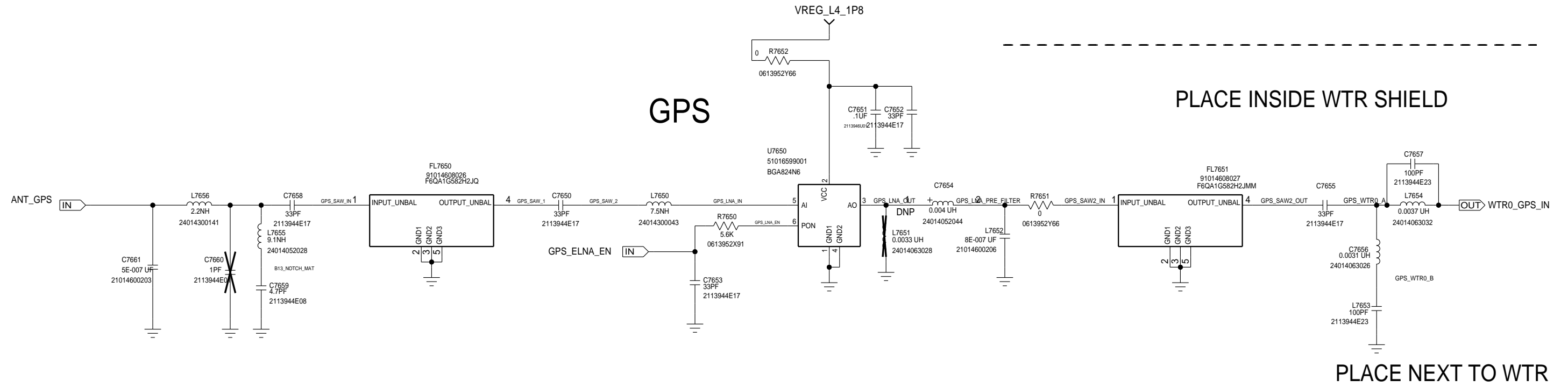

GPS

PLACE INSIDE WTR SHIELD

PLACE NEXT TO WTR

APPROVALS		MOTOROLA MOBILE DEVICES	
ENGINEER: MMI		BLOCK TITLE:	
LAST MODIFIED BY: MMI		block_rfe	
Wed May 03 08:55:28 2016 MOTOROLA CONFIDENTIAL RESTRICTED <small>THE DRAWING ON THIS PRINT AND INFORMATION THEREWITH ARE PROPRIETARY TO MOTOROLA AND SHALL NOT BE USED OR DISCUSSED IN WHOLE OR IN PART WITHOUT MOTOROLA'S CONSENT. © COPYRIGHT, MOTOROLA. THIS DOES NOT IMPLY PUBLICATION</small>		PROJECT NAME B 84016562001_a.cpm	REV 01
		CAD FILE NAME:	
		PAGE 52 OF 61	

WTR2965 BB RF

REF 3000-3049

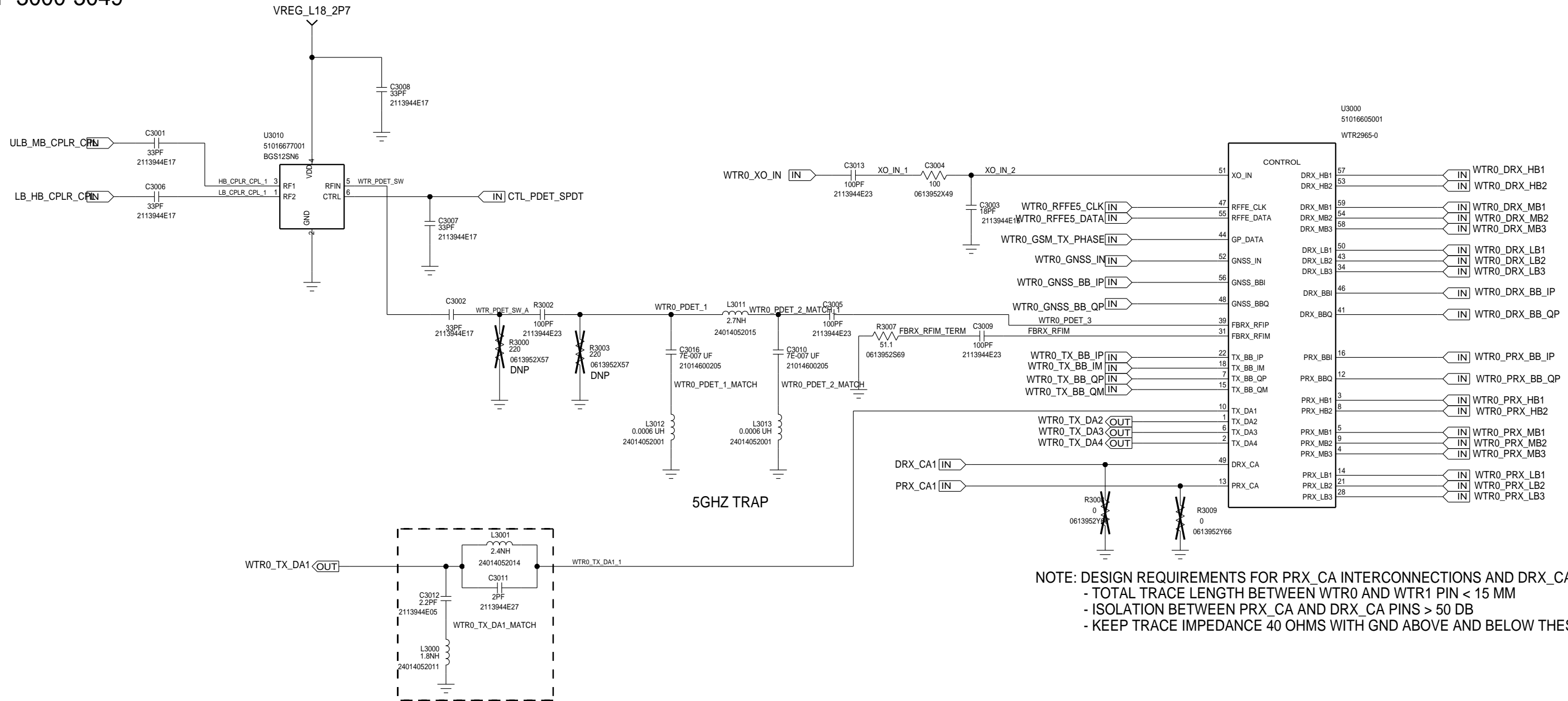

NOTE: THIS LC NOTCH IS REQUIRED TO MEET 4FMOD SPECS IN B13 BAND.

BASED ON 80-NP237-43 REV. A

MOTOROLA MOBILITY CONFIDENTIAL RESTRICTED-MDB TRACKED TRACKEDANDBLOCKED

APPROVALS		MOTOROLA MOBILE DEVICES	
ENGINEER: MMI		BLOCK TITLE:	
LAST MODIFIED BY: Thu May 05 16:54:10 2016		blk_wtr2965	
MOTOROLA CONFIDENTIAL RESTRICTED		PROJECT NAME	REV
<small>THE DRAWING ON THIS PRINT AND INFORMATION THEREWITH ARE PROPRIETARY TO MOTOROLA AND SHALL NOT BE USED OR DISCUSSED IN WHOLE OR IN PART WITHOUT MOTOROLA'S CONSENT. © COPYRIGHT, MOTOROLA. THIS DOES NOT IMPLY PUBLICATION</small>		B 84016562001_a.cpm	01
		CAD FILE NAME:	PAGE 58 OF 61

WTR2965 POWER

REF 3100-3149

U3000

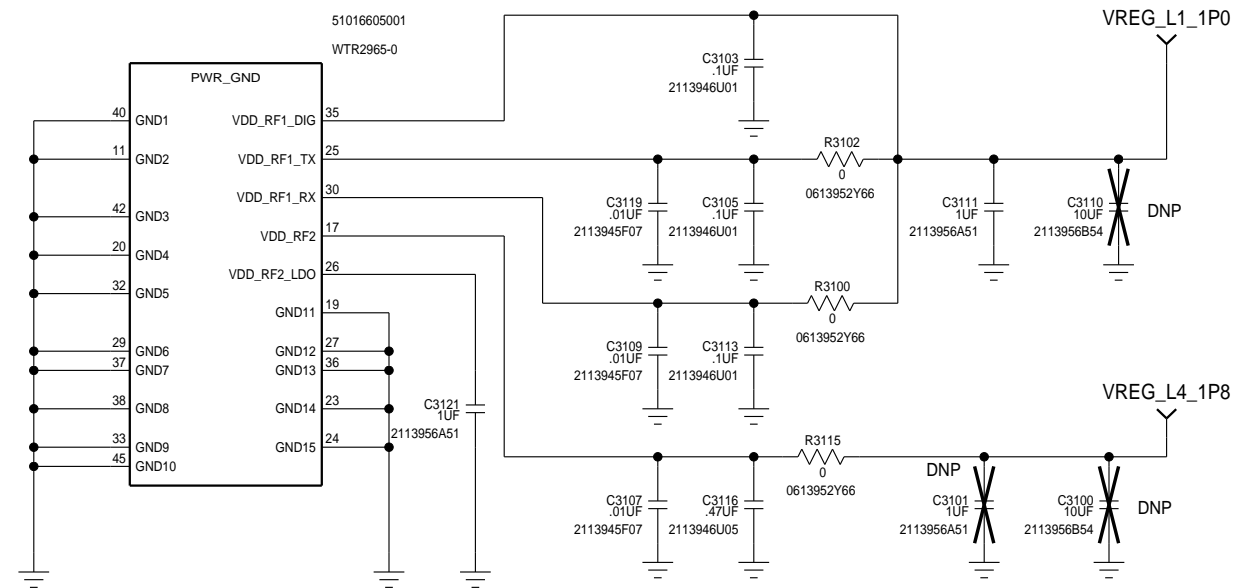

NOTE: C3119, C3109, C3107 ARE PRIORITY 1 AND SHOULD BE PLACED CLOSEST TO VDD PINS.

BASED ON 80-NL713-44 REV. A

MOTOROLA MOBILITY CONFIDENTIAL RESTRICTED-MDB TRACKED TRACKEDANDBLOCKED

APPROVALS		MOTOROLA MOBILE DEVICES	
ENGINEER: MMI		BLOCK TITLE:	
LAST MODIFIED BY: MMI Thu May 05 16:54:10 2016		blk_wtr2965	
MOTOROLA CONFIDENTIAL RESTRICTED THE DRAWING ON THIS PRINT AND INFORMATION THEREWITH ARE PROPRIETARY TO MOTOROLA AND SHALL NOT BE USED OR DISCUSSED IN WHOLE OR IN PART WITHOUT MOTOROLA'S CONSENT. © COPYRIGHT, MOTOROLA. THIS DOES NOT IMPLY PUBLICATION		PROJECT NAME	REV
		B 84016562001_a.cpm	01
CAD FILE NAME:		PAGE 59 OF 61	

CA_WTR2965 BB RF

REF 3050-3099

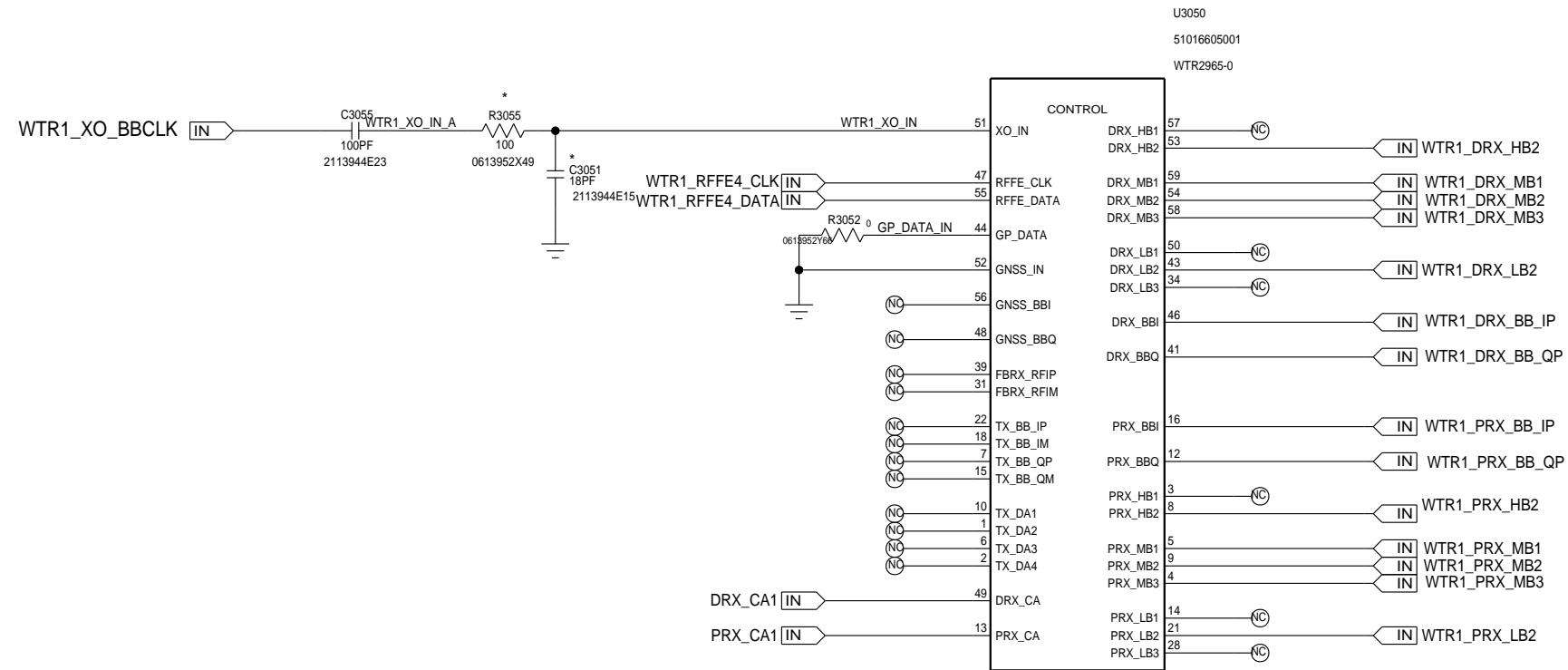

NOTE: DESIGN REQUIREMENTS FOR PRX_CA INTERCONNECTIONS AND DRX_CA INTERCONNECTIONS:

- TOTAL TRACE LENGTH BETWEEN WTR0 AND WTR1 PIN < 15 MM
- ISOLATION BETWEEN PRX_CA AND DRX_CA PINS > 50 DB
- KEEP TRACE IMPEDANCE 40 OHMS WITH GND ABOVE AND BELOW THESE TRACES

APPROVALS		MOTOROLA MOBILE DEVICES	
ENGINEER: MMI		BLOCK TITLE:	
LAST MODIFIED BY: Thu May 05 16:54:08 2016		ca_wtr2965	
MOTOROLA CONFIDENTIAL RESTRICTED <small>THE DRAWING ON THIS PRINT AND INFORMATION THEREWITH ARE PROPRIETARY TO MOTOROLA AND SHALL NOT BE USED OR DISCUSSED IN WHOLE OR IN PART WITHOUT MOTOROLA'S CONSENT. © COPYRIGHT, MOTOROLA. THIS DOES NOT IMPLY PUBLICATION</small>		PROJECT NAME B 84016562001_a.cpm	REV 01
		CAD FILE NAME:	
		PAGE 60 OF 61	

CA_WTR2965 POWER

REF 3150-3199

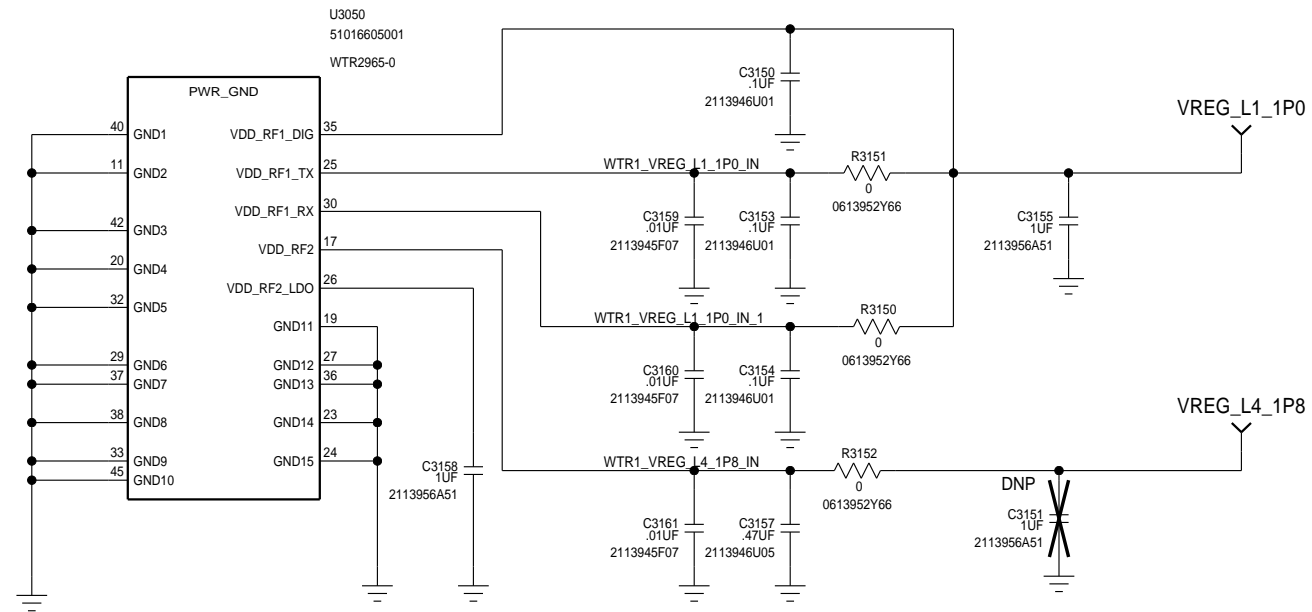

NOTE: C3159, C3160, C3161 ARE PRIORITY 1 AND SHOULD BE PLACED CLOSEST TO VDD PINS.

APPROVALS		 MOTOROLA MOBILE DEVICES	
ENGINEER: MMI		BLOCK TITLE:	
LAST MODIFIED BY: MMI Thu May 05 16:54:09 2016		ca_wtr2965	
MOTOROLA CONFIDENTIAL RESTRICTED <small>THE DRAWING ON THIS PRINT AND INFORMATION THEREWITH ARE PROPRIETARY TO MOTOROLA AND SHALL NOT BE USED OR DISCUSSED IN WHOLE OR IN PART WITHOUT MOTOROLA'S CONSENT. © COPYRIGHT, MOTOROLA. THIS DOES NOT IMPLY PUBLICATION</small>		PROJECT NAME B 84016562001_a.cpm	REV 01
		CAD FILE NAME:	
		PAGE 61 OF 61	