

LUX PRODUCT OVERVIEW



Product Portfolio

	Callisto	Lux
Battery	2600 mAh - 24 Hr Battery	3630 mAh - 48 Hr Battery
Display	5.0" HD TFT (1280 x 720)	5.5" Full HD TFT (1080 x 1920)
Processor	MSM8916 1.4 GHz Quad-Core	MSM8936 1.7 GHz Quad-Core
RF	LTE CAT 4 No CA	LTE CAT 4 No CA
Connectivity	WiFi 802.11b/g/n 2,4GHz, BT 4.0LE, microUSB, 3.5mm HSJ	WiFi 802.11b/g/n 2,4GHz, 5.0GHz, BT 4.1LE, microUSB, 3.5mm HSJ
Camera	13 MP Dual CCT RF / FF 5MP	21 MP Dual CCT / FF 5MP (LSI)
Memory	1GB 8GB,16GB SD	2GB 16GB, 32GB SD
SIM support	Dual nano SIM supported mkts	Dual nano SIM in supported markets
ID	72.4 x 142.1 x 12.1 mm, 155g	75 x 148.5 x 11 mm, 175g
Sensors	2x Accelerometer, Ambient Light, Proximity, Magnetometer, M0 sensor Hub	2x Accelerometer, Ambient Light, Proximity, Magnetometer, M0 Sensor Hub
Audio	Earpiece, loudspeaker, 3-Mic Support	Earpiece + Loudspeaker, 3-Mic Support
Enclosure	Black and white; removable back covers, MotoMaker	Black and white; removable inlay; MotoMaker
WaterProof	IPx7	Splash-proof



Lux POR SKU Summary



RESTRICTED :: MOTOROLA.COM

Banding	Memory	FM	AoV	NFC	PCB BOM	CMF	Endo #	# of SIMs	Sales Model	Bands	
Verizon (Single SIM)	16GB	n/a		Yes	1	Dark	1	1	1	Summary: <ul style="list-style-type: none"> 8 Stockable SKUs Wuhan will build LDA assemblies and ship to JAG / Argentina. 	
						Light	2		2		
ROW - DE (Single SIM)	16GB				2	Dark	3	1	3		
						Light	4		4		
	32GB - DE, UK, FR (Motomaker)				3	Dark	5		5		
						Light	6		6		
ROW (Dual SIM)	16GB				2	Dark	3	2	7		
						Light	4		8		
LATAM (Single SIM)	16GB	Yes	Yes	n/a	4	Dark	7	1	9		CDMA Bands: NA WCDMA Bands: 1d,2d,4d,5d,8d LTE Bands: 1,2,3,4,5,7,8,12,17,25,28a,28b
	Light					8	10				
LATAM (Single SIM)	32GB - MX (Motomaker)				5	Dark	9	2	11		
						Light	10		12		
	16GB				4	Dark	7		13		
						Light	8		14		
LATAM (Dual SIM)	32GB - Brazil Only (Bundle)				5	Dark	9		15		
						Light	10		16		
China CDMA (Dual SIM)	16GB				6	Dark	11	2	17	CDMA Bands: BC0d WCDMA Bands: 1d,2,5d,8d LTE Bands: 1,3,7,18,39,40,41 TD-SCDMA: 34,39	
						Light	12		18		
	32GB - China (Motomaker)				7	Dark	13		19		
						Light	14		20		

Lux XCVR Matrix – P1C / P2A

XCVR Structure	Description
SJUG7211AA	ASSY,XCVR,BLK 16GB - LATAM
SLG6757AA	Main,BRD,Proto,16GB - LATAM



Proposed Process Flow – P1C

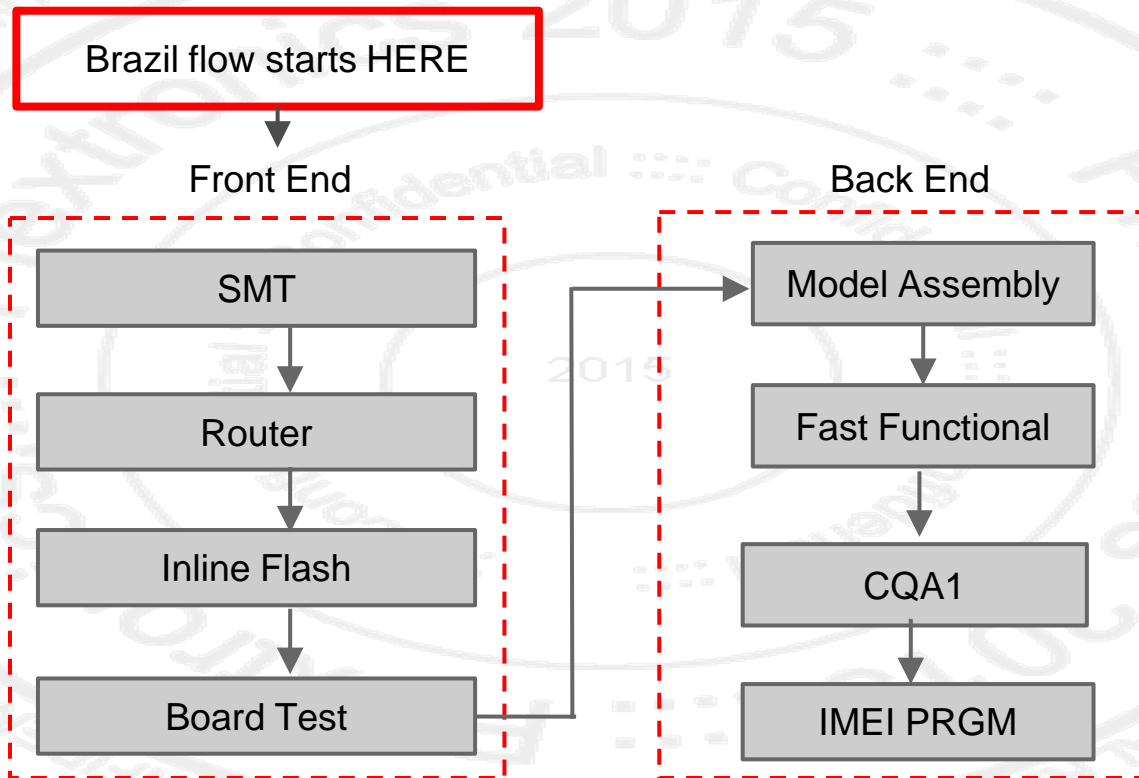

Proposed Process Flow – P2A

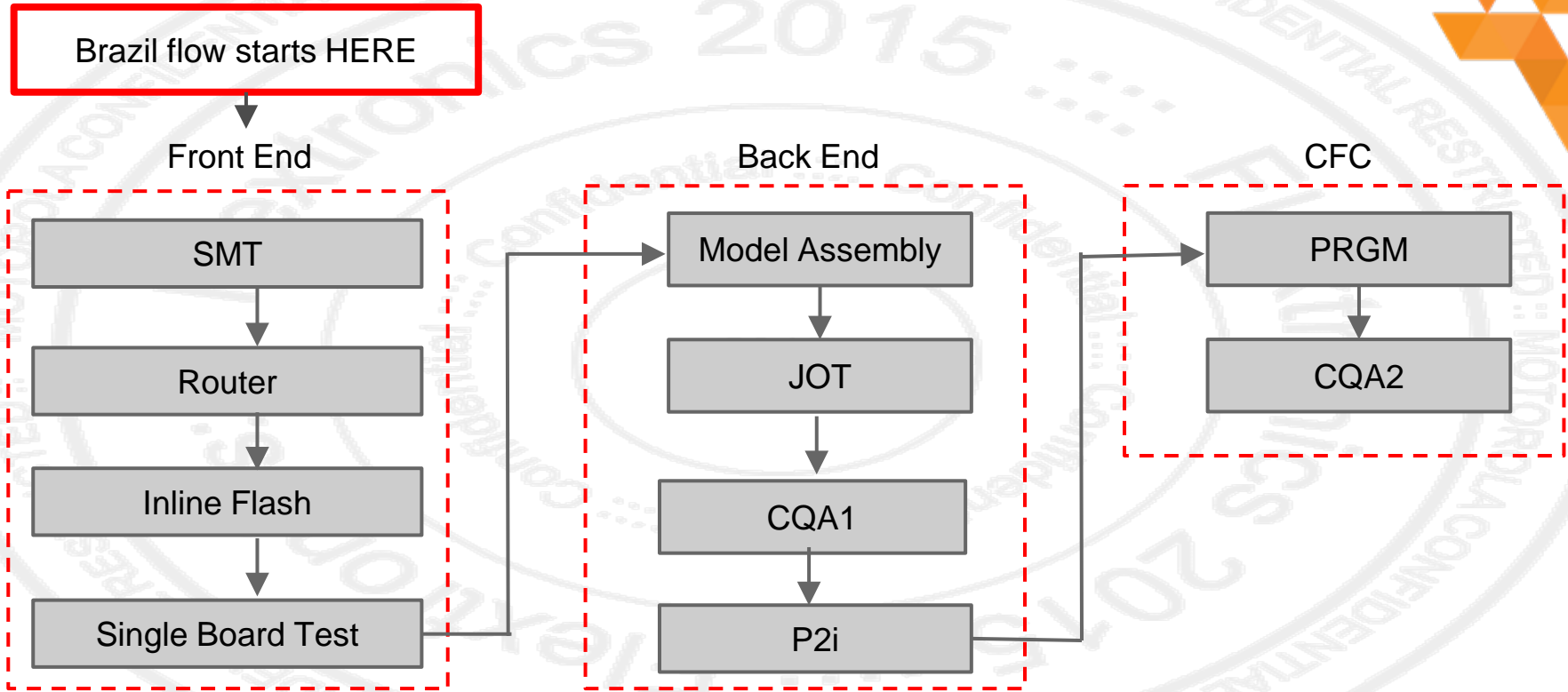

Boards on Lux

PCB PN#	Description	Local or Imported
SLG6757A (P1C/P2A PCBA)	Main Board	Local
51016431002	SENSOR,DIG ALS, PROXIMITY, AND IRBEAM MDL 8-PIN DFN	Local

Note: Review PPB control



Product Name	SMT Part Count		PCB Part No.	PCB Thickness	Panel size	Board per panel	Board size
	Top side	Bottom side					
Lux	Top side 1219	Bottom side 30	84016439001	6 Layer ELIC 0.420	137.72. x 145.22	2-up	70.32 x 145.22

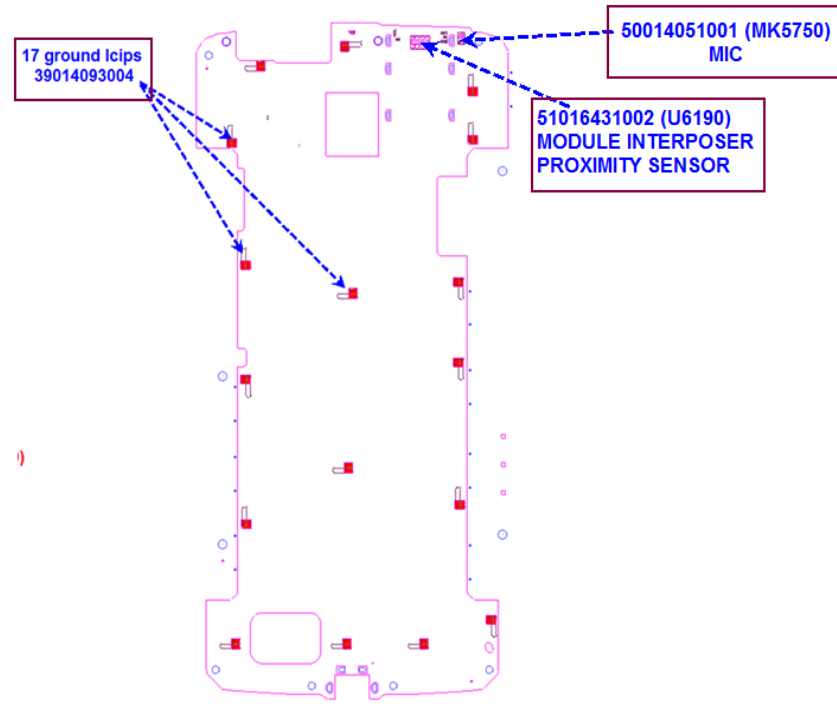
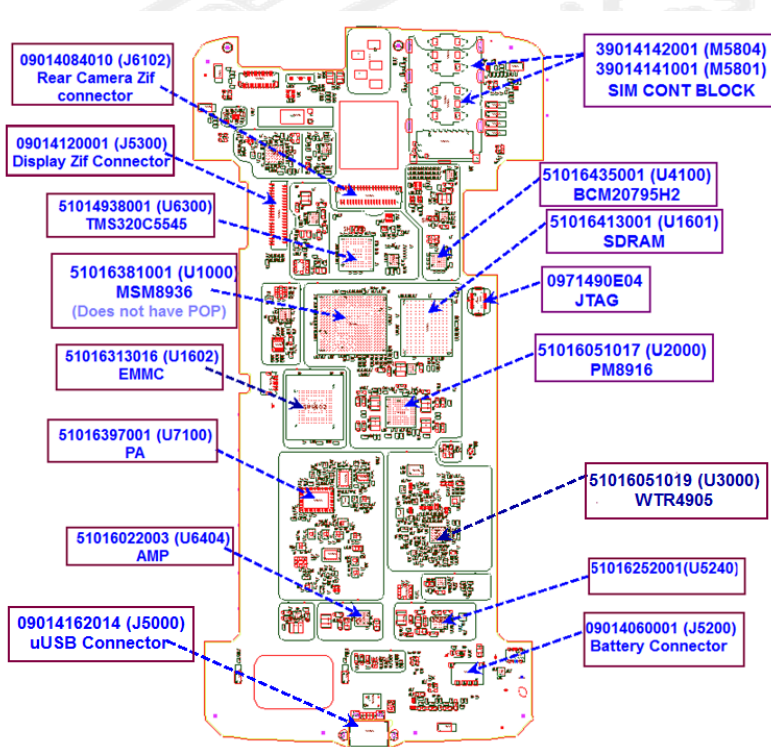

- Key takeaways**
- 0.37mm thick pcb (requires special handling)
 - 13 shield placements
 - No PoP components

Parts Types Overview

WLCSP - Wafer Level
Chip Scale Package

Gemo Package	Quantity
0201	996
0402	118
0603	45
QFN	2
DFN	8
BGA	26
LGA	8
DIODE	44
Filter	36
WLCSP	6
Connectors	16
Shields	16
Ground Contact Clips	17
Solder Pellets	4
POP	0 (Lynx does not have POP)

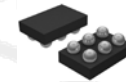

BGA - Ball Grid Array

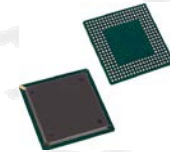

LGA - Land grid array

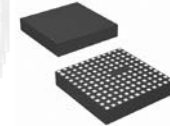

DFN - Dual Flat No leads



QFN - Quad Flat No leads



PCB Shields

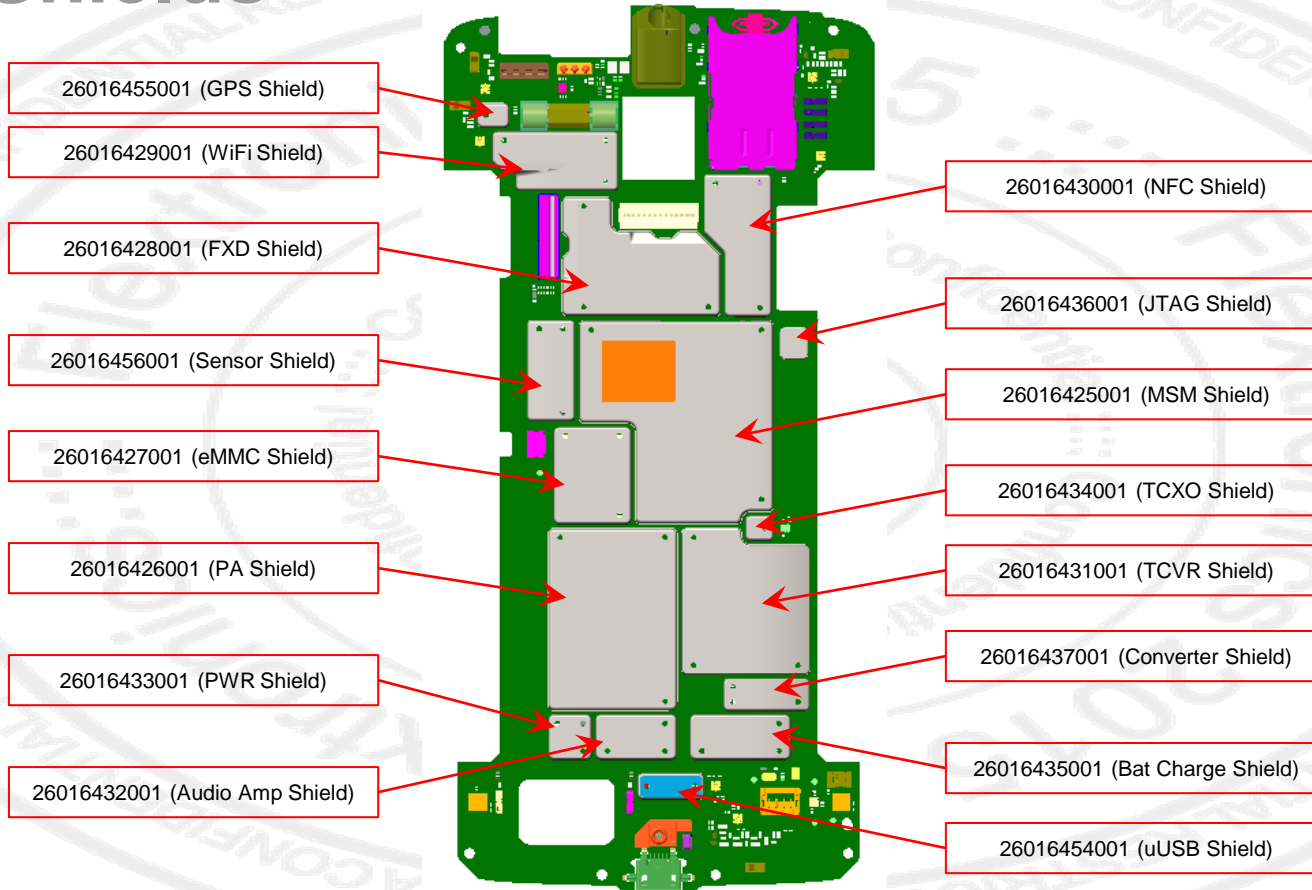

Lux Panelization layout : 137.72.0 x 145.22 mm

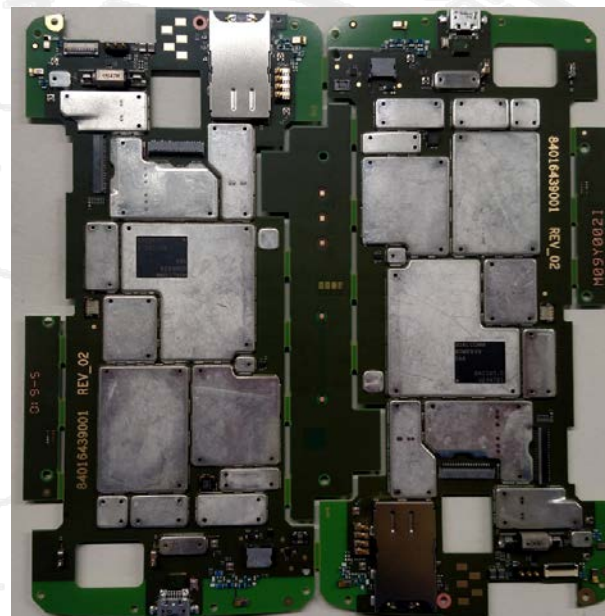
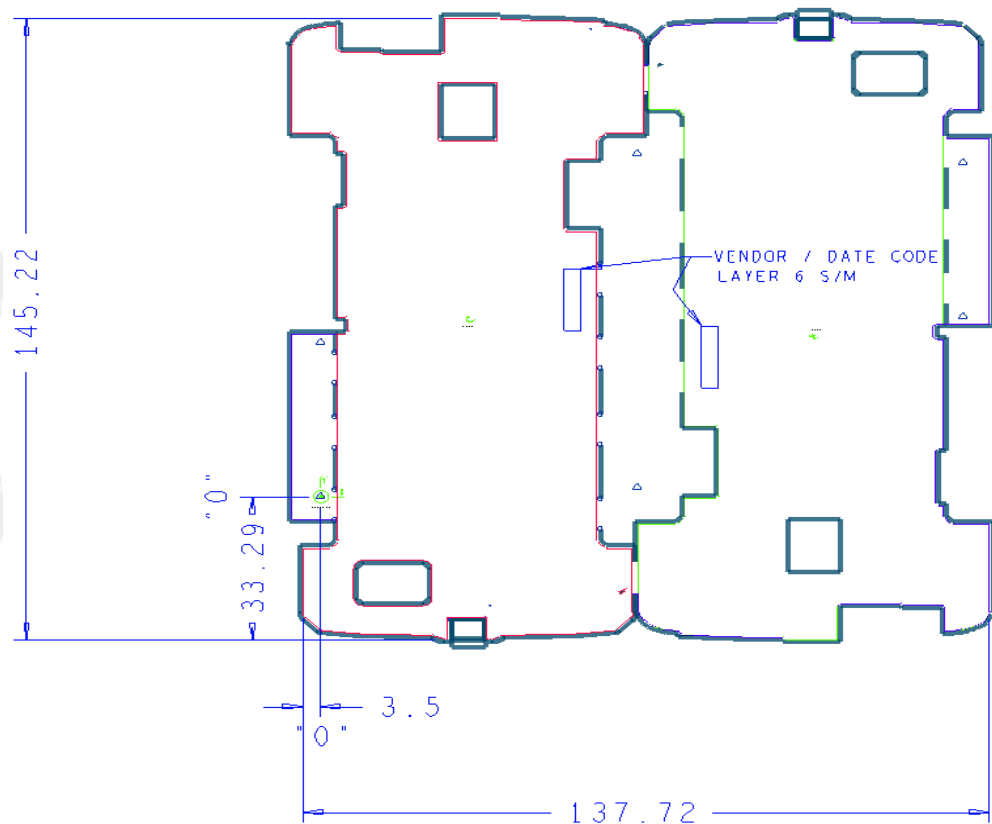

Lux Exploded View

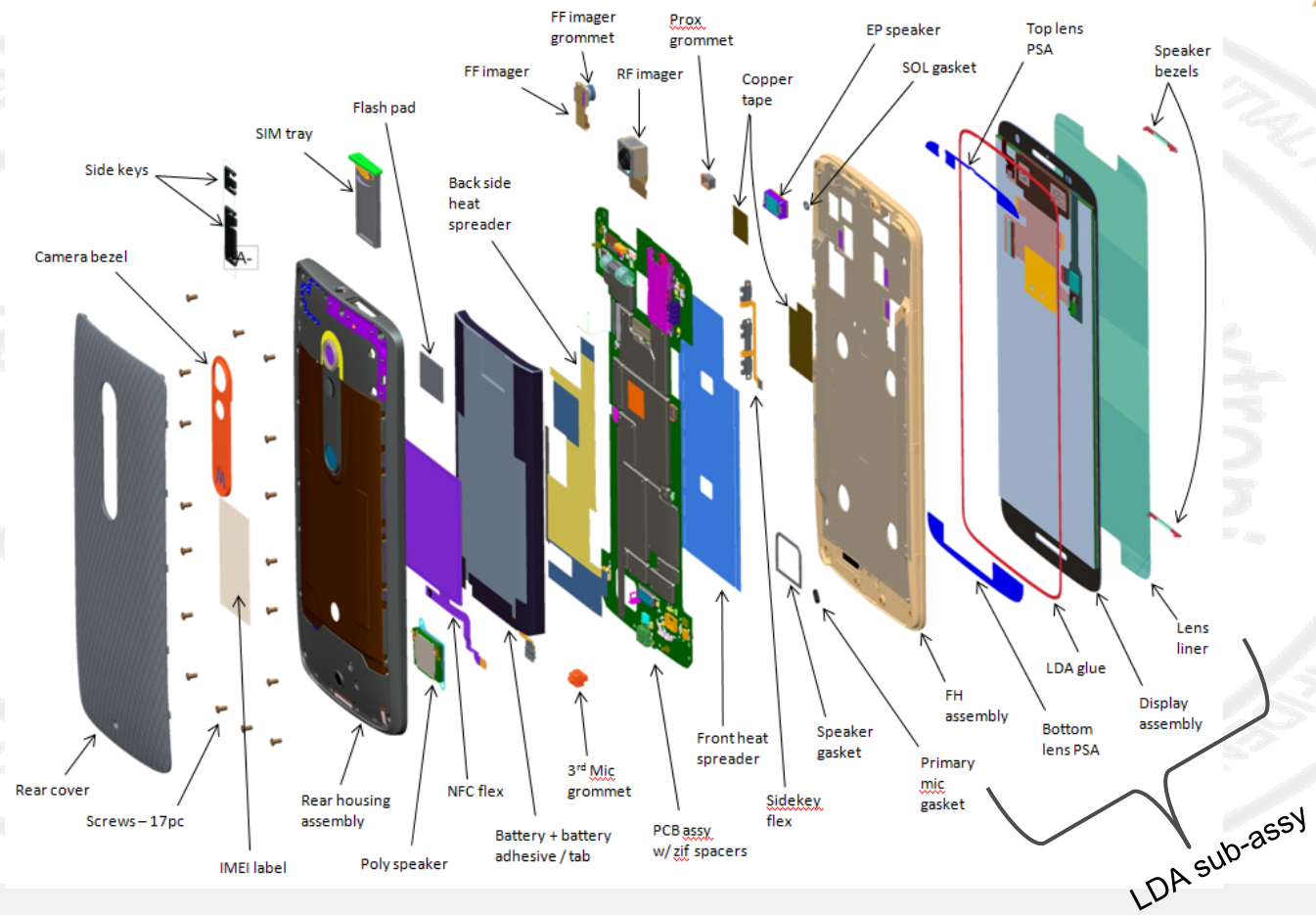



Customer Customization

2015



Arctic Fox

Customizable options for Lux (AFx):

Factory (XCVR Level):

- Housing Colors (black & white);
- Memory 16GB | 32GB for Afx;
- Power and Volume keys.

MotoMaker (CFC):

- Rear cover (Inlay);
- Camera Bezel;
- Earpiece / Loudspeaker Bezels.

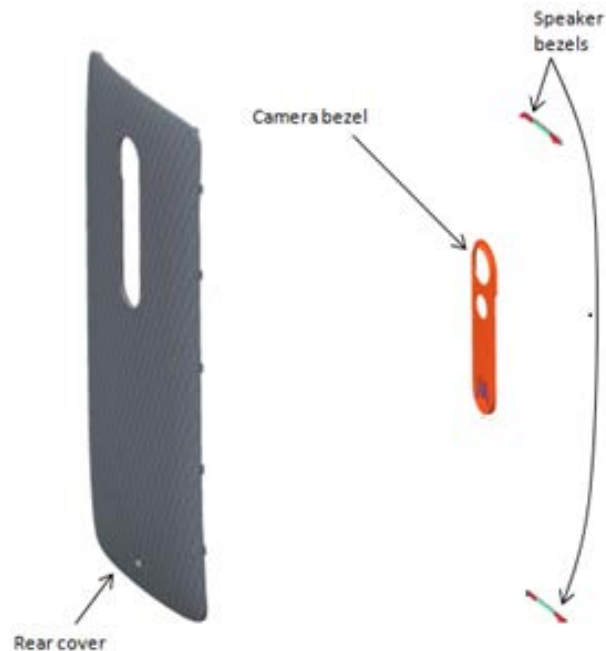

P1A Slides

2015



P1A Part Placement (Front Side)

17 Ground Contacts require special handling

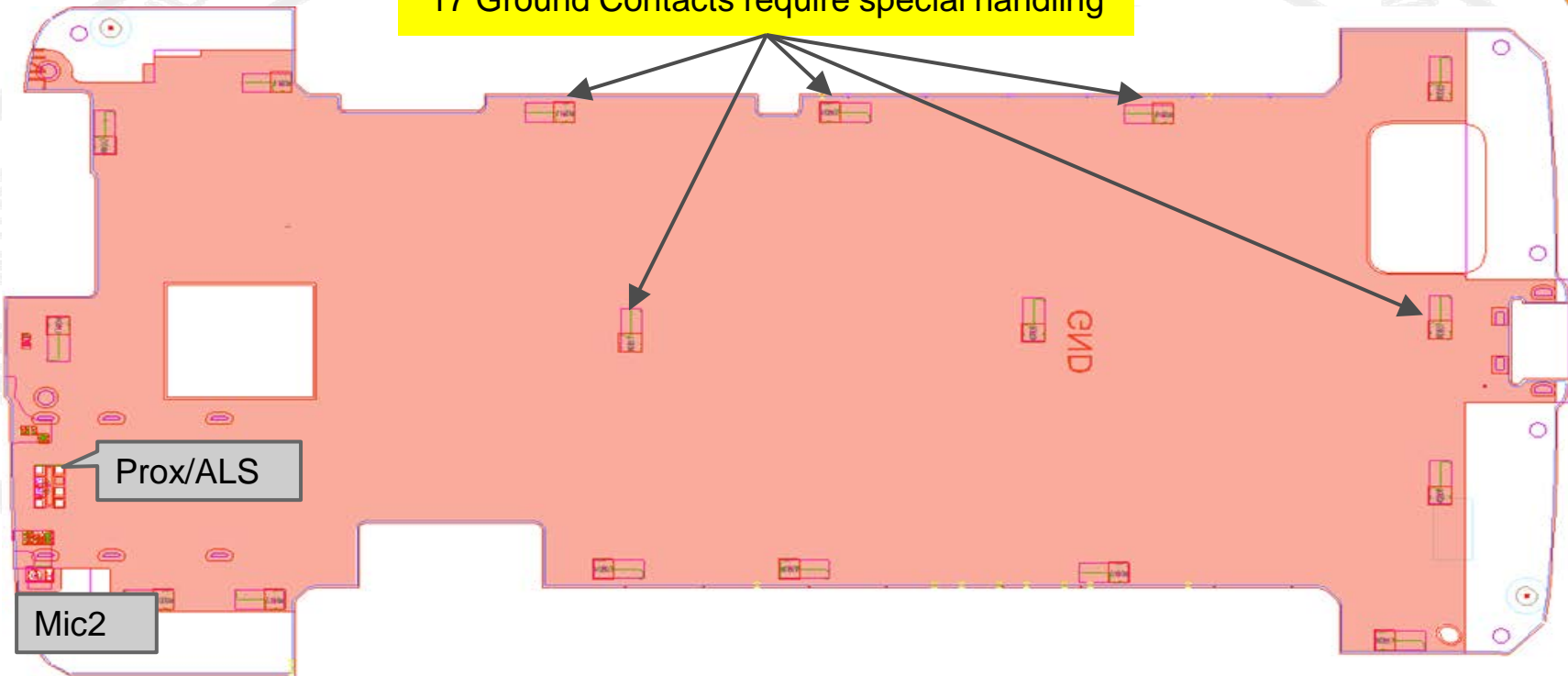

P1A Part Placement (Back Side)

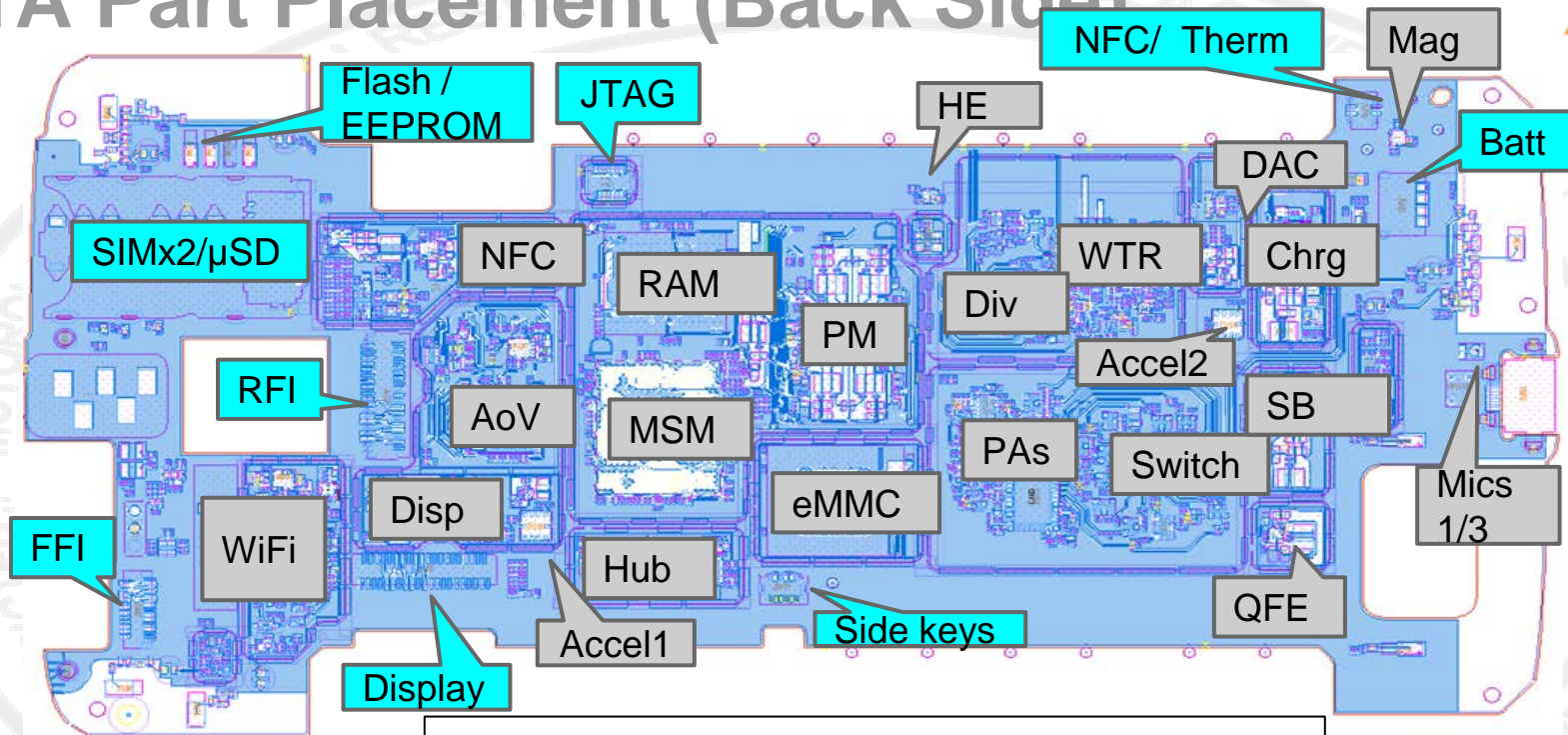

Key takeaways

- 0.37mm thick pcb (requires special handling)
- 13 shield placements
- No PoP components