

CALLISTO_B

SYSTEM 4.0
04-S28-2014
05/11/15

REVISIONS				
ZONE	LTR	DESCRIPTION	DATE	APPROVED

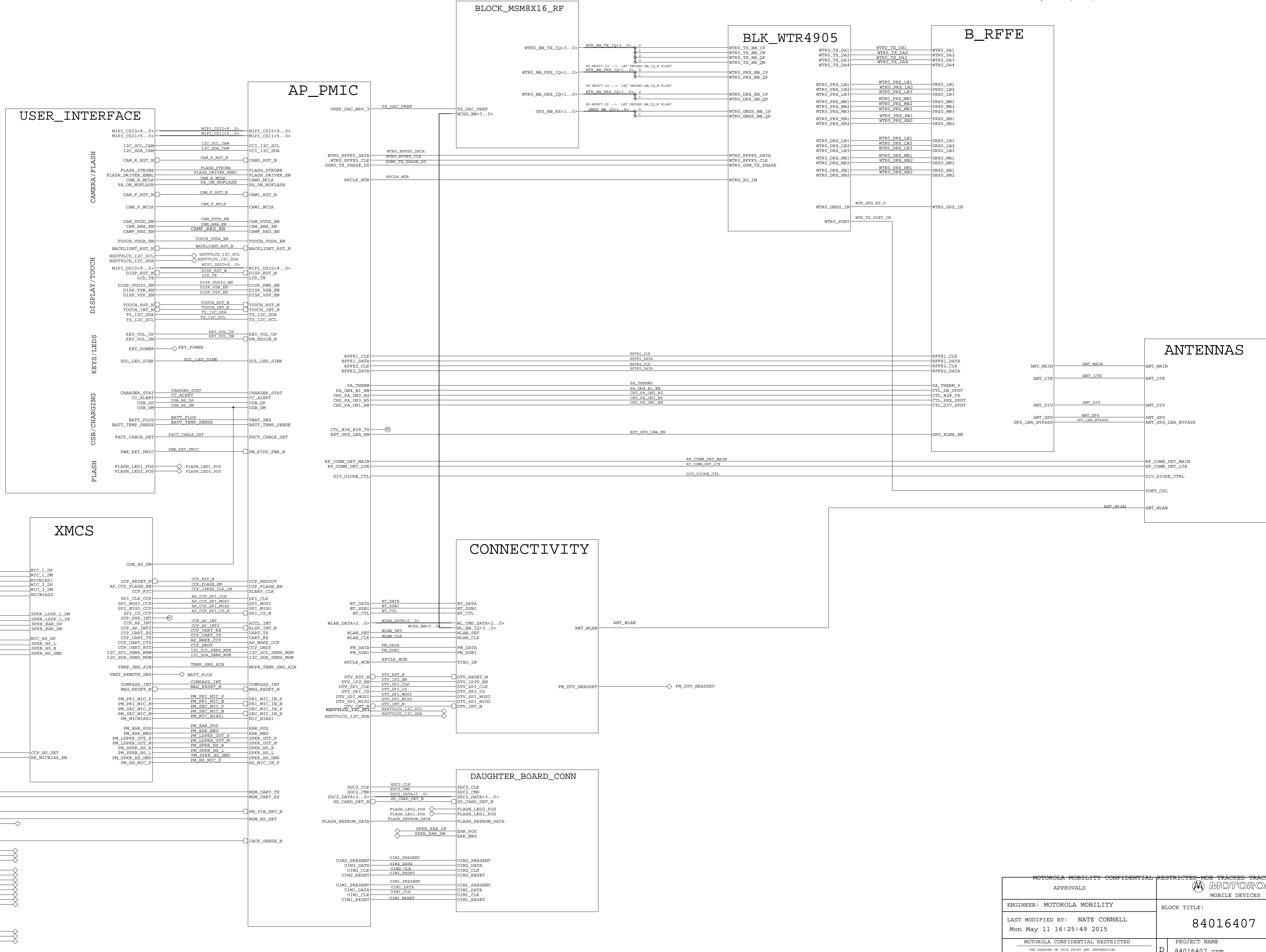

APPROVALS		MOTOROLA MOBILE DEVICES	
ENGINEER: MOTOROLA MOBILITY		BLOCK TITLE:	
LAST MODIFIED BY: NATE CONNELL Mon May 11 16:25:49 2015		84016407	
<small>MOTOROLA CONFIDENTIAL RESTRICTED</small>		PROJECT NAME	REV
<small>THE DRAWING OF THIS PRINT AND INFORMATION THEREON ARE PROPRIETARY TO MOTOROLA AND SHALL NOT BE USED OR DISCLOSED IN WHOLE OR IN PART WITHOUT MOTOROLA'S CONSENT. © COPYRIGHT, MOTOROLA. THIS DOCUMENT IS UNCLASSIFIED.</small>		D 84016407.cpm	01
		CAD FILE NAME:	PAGE 1 OF 47

CALLISTO A ME/SHIELDS

CALLISTO REFERENCE DESIGNATOR RANGES BY BLOCK

- 000 - 499: ANTENNA
- 500 - 599: USER INPUT
- 600 - 799: POWER
- 1000-2999:
- 1600-1699: MEMORY
- 2000-2999: PM8916
- 3000-3199: WTR4905
- 4000-4499: CONNECTIVITY
- 4500-4999: AUDIO FE
- 5300-5399: DISPLAY
- 5500-5999: CAMERA
- 6000-6999: XMCS
- 7000-7799, 8000-8020: RFFE
- 7800-7899:
- 9000-9999: PRODUCT-SPECIFIC (FILTERING, 100PF CAPS)

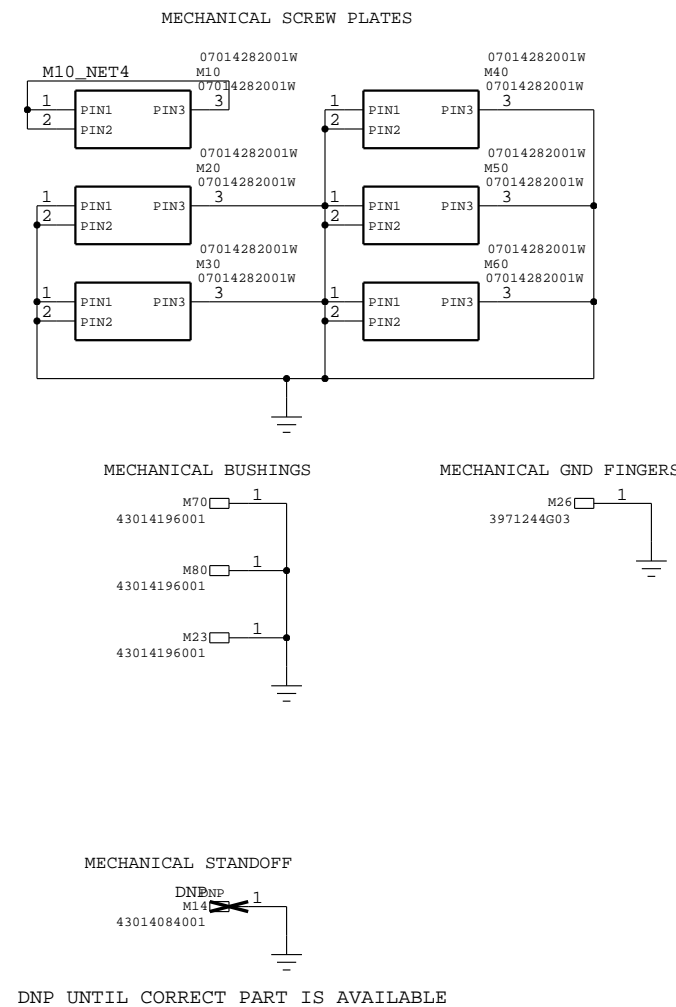
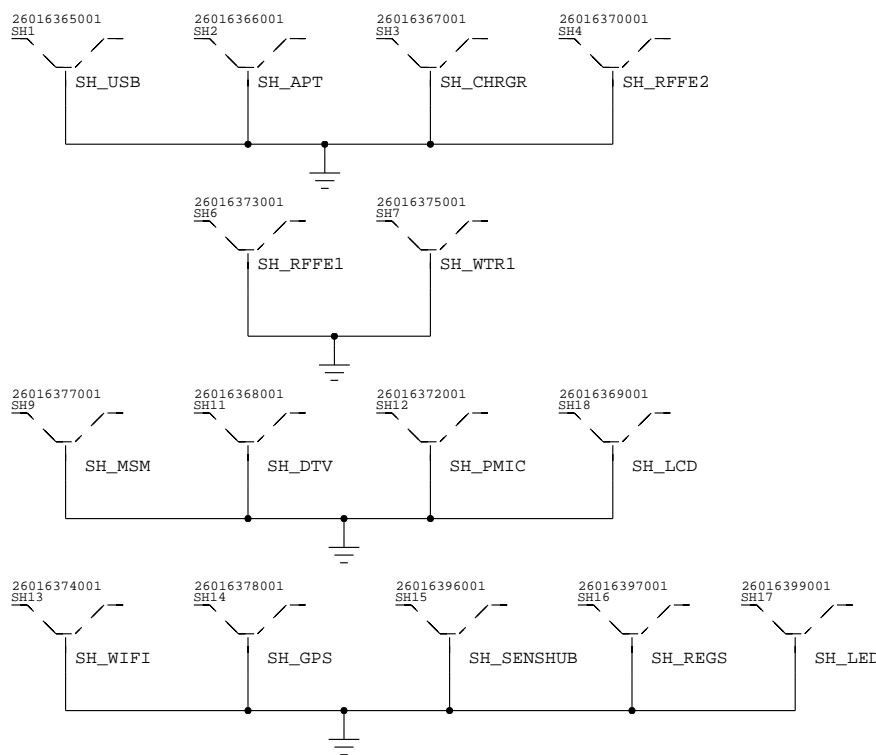

DNP UNTIL CORRECT PART IS AVAILABLE

MOTOROLA MOBILITY CONFIDENTIAL RESTRICTED-MDB TRACKED TRACKEDANDBLOCKED

APPROVALS		MOTOROLA MOBILE DEVICES	
ENGINEER:		BLOCK TITLE:	
LAST MODIFIED BY: Mon May 11 16:30:05 2015		84016407	
MOTOROLA CONFIDENTIAL RESTRICTED THE DRAWING ON THIS PRINT AND INFORMATION THEREWITH ARE PROPRIETARY TO MOTOROLA AND SHALL NOT BE USED OR DISCUSSED IN WHOLE OR IN PART WITHOUT MOTOROLA'S CONSENT. © COPYRIGHT, MOTOROLA. THIS DOES NOT IMPLY PUBLICATION		PROJECT NAME	REV
		B 84016407.cpm	01
CAD FILE NAME:		PAGE 2 OF 47	

ANTENNAS

REF 000-499

REVISIONS				
REV	ECN	DESCRIPTION	MADE BY	APPROVED

MAIN ANTENNA - 1
BOTTOM LEFT MAIN ANTENNA
850/900/1900/2100+QUAD-GSM

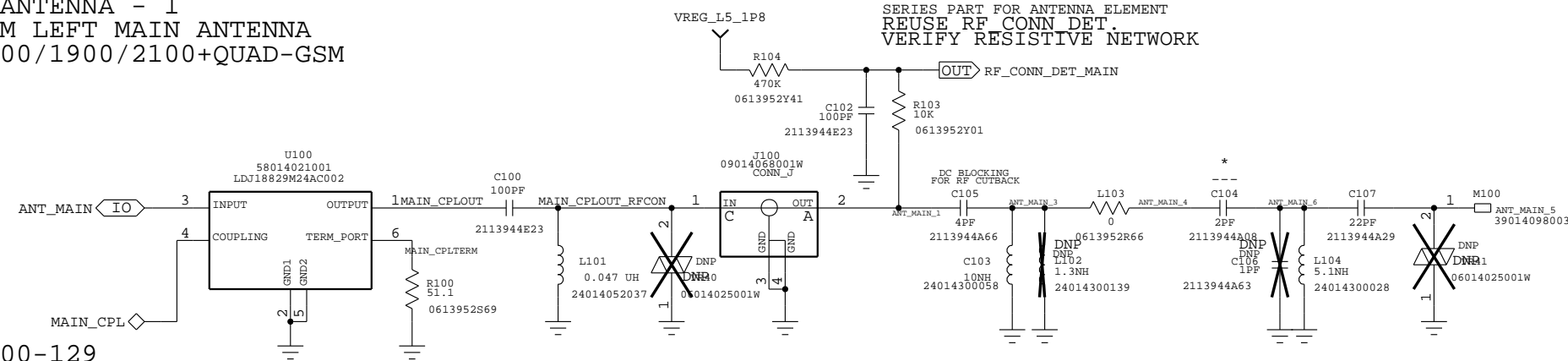

REF:100-129

MAIN ANTENNA - 2
BOTTOM RIGHT MAIN ANTENNA
LOW/HIGH-HIGH LTE BAND

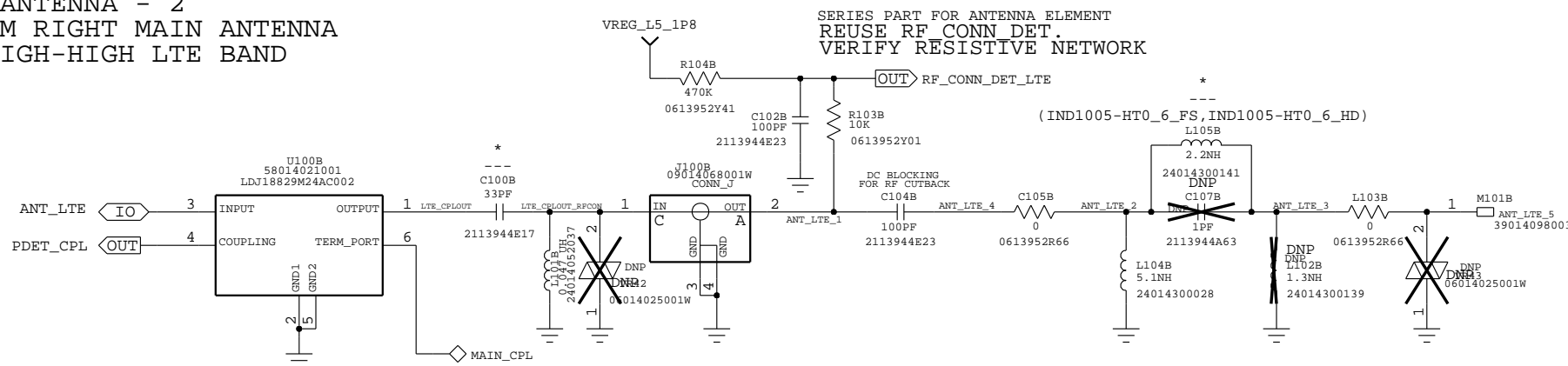

REF:100B-129B

DIVERSITY ANTENNA
TOP ANTENNA
(NEXT TO AUDIO JACK)

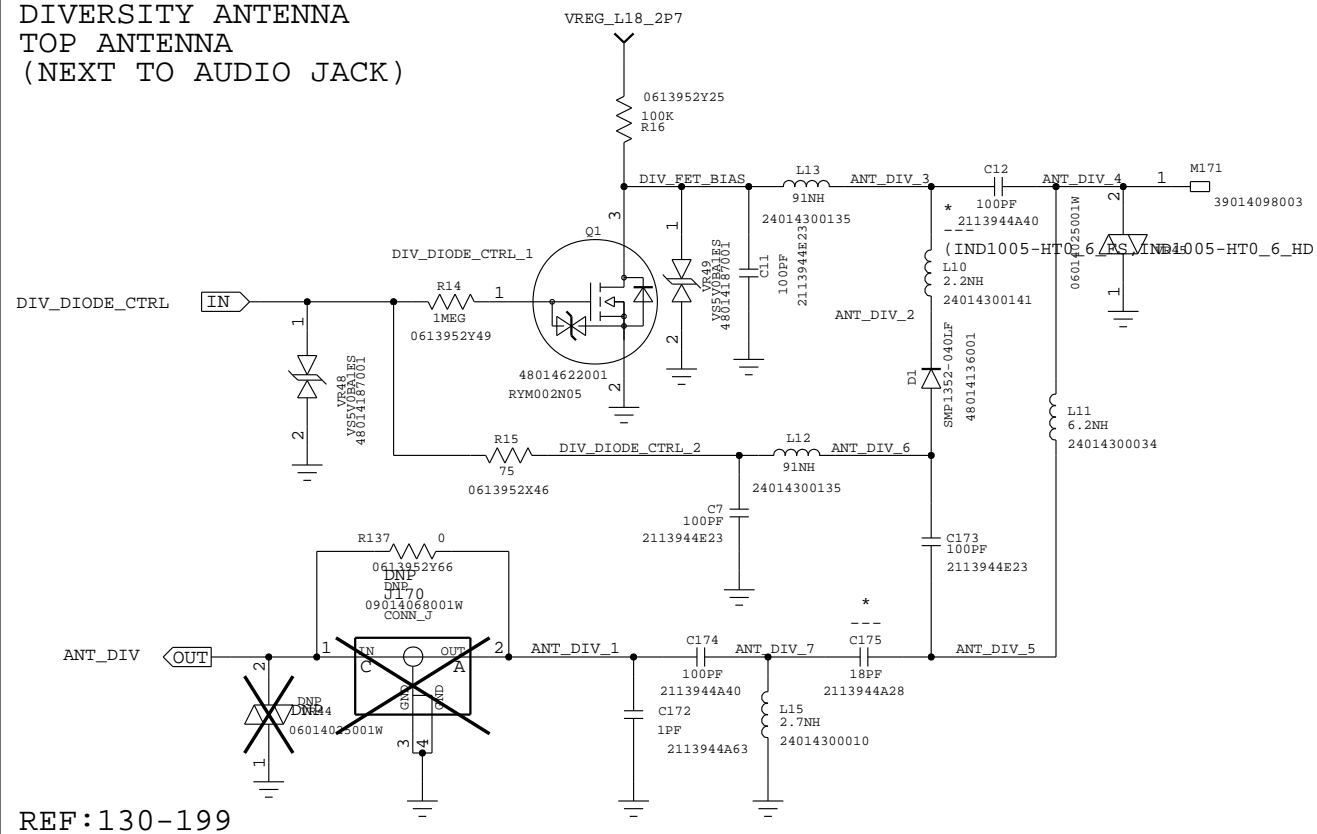

REF:130-199

SIDE ANTENNA (ABOVE VOLUME KEYS)
GPS/BT/WLAN ANTENNA

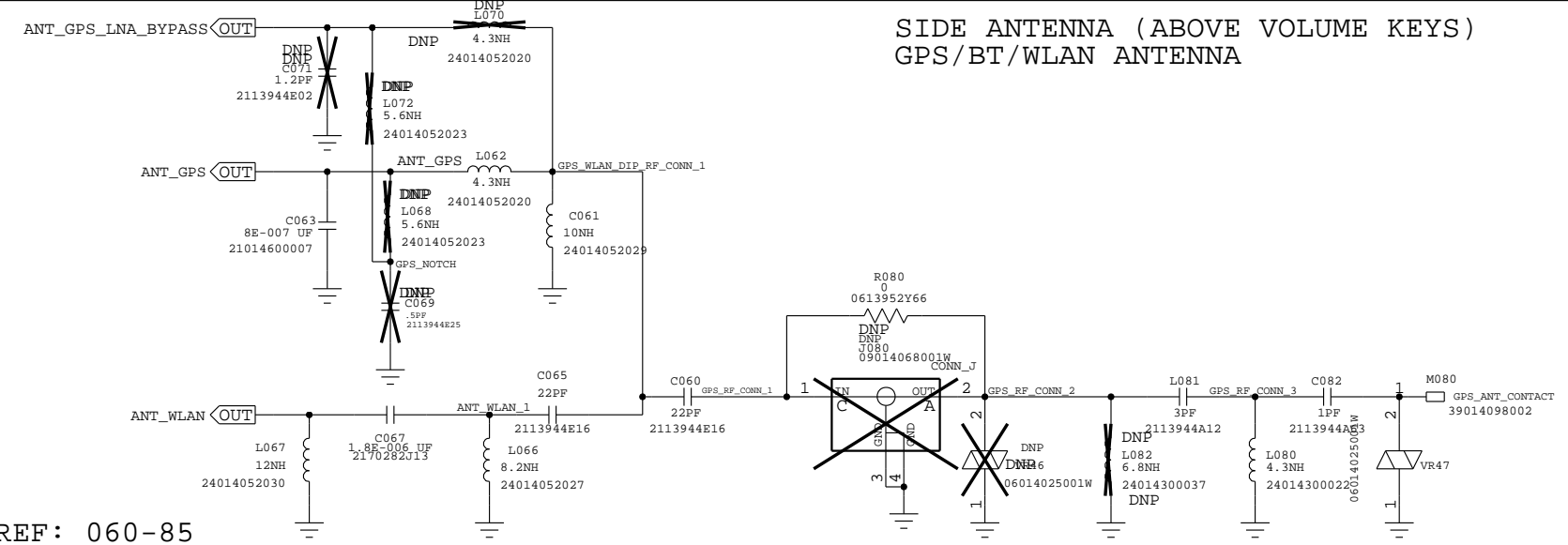

REF: 060-85

LAST MODIFIED: Mon May 11 16:30:19 2015

DRAWING NUMBER: 84			
DRAWN BY:	DATE:	TITLE:	REV 01
LEAD ENGINEER:	DATE:		SIZE B
ASSY NUMBER:	PCB FILE NAME:	PAGE 3 OF 47	

WCN3620 RF/CTRL

REF 4600-4699

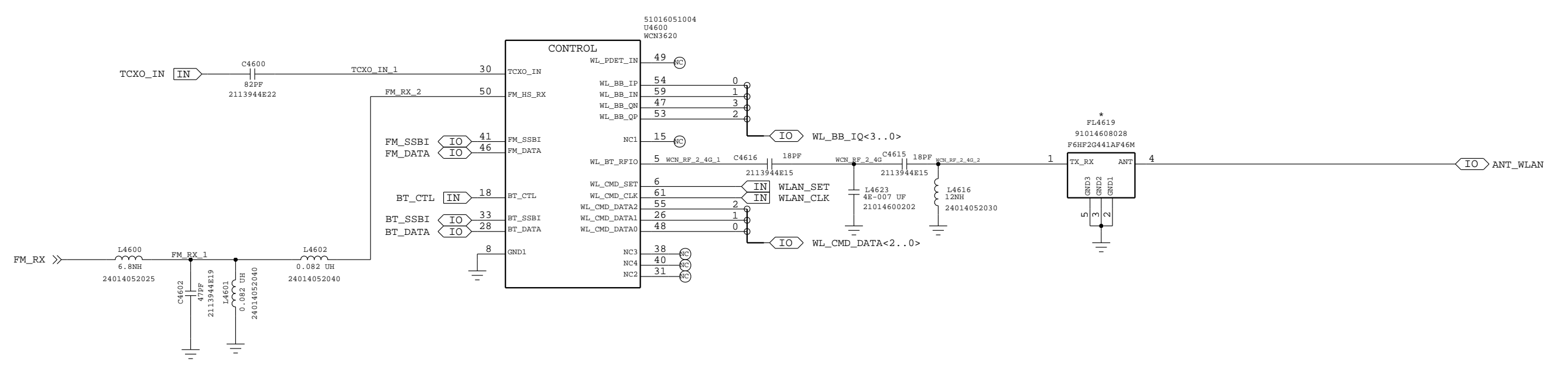

BASED ON 80-WL006-44 REV C

APPROVALS		MOTOROLA MOBILE DEVICES	
ENGINEER :		BLOCK TITLE :	
LAST MODIFIED BY: FROEHLING Mon May 11 16:30:21 2015		connectivity	
MOTOROLA CONFIDENTIAL RESTRICTED <small>THE DRAWING ON THIS PRINT AND INFORMATION THEREWITH ARE PROPRIETARY TO MOTOROLA AND SHALL NOT BE USED OR DISCUSSED IN WHOLE OR IN PART WITHOUT MOTOROLA'S CONSENT. © COPYRIGHT, MOTOROLA. THIS DOES NOT IMPLY PUBLICATION</small>		PROJECT NAME B 84016407.cpm	REV 01
		CAD FILE NAME :	PAGE 4 OF 47

WCN3620 POWER

REF 4700-4749

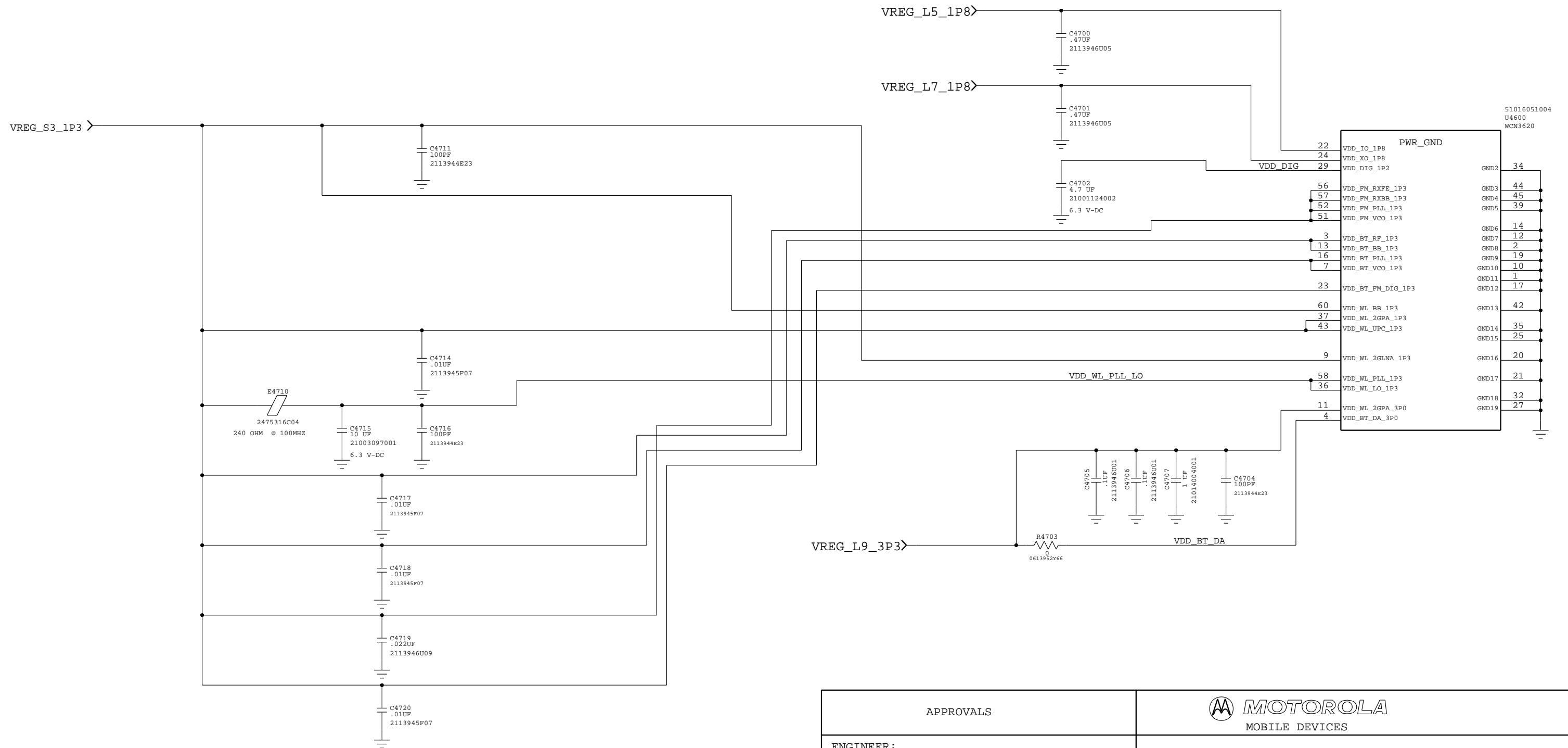

BASED ON 80-WL006-44 REV C

APPROVALS		MOTOROLA MOBILE DEVICES	
ENGINEER :		BLOCK TITLE :	
LAST MODIFIED BY: FROEHLING Mon May 11 16:30:23 2015		connectivity	
MOTOROLA CONFIDENTIAL RESTRICTED <small>THE DRAWING ON THIS PRINT AND INFORMATION THEREWITH ARE PROPRIETARY TO MOTOROLA AND SHALL NOT BE USED OR DISCUSSED IN WHOLE OR IN PART WITHOUT MOTOROLA'S CONSENT. © COPYRIGHT, MOTOROLA. THIS DOES NOT IMPLY PUBLICATION</small>		PROJECT NAME B 84016407.cpm	REV 01
		CAD FILE NAME :	PAGE 5 OF 47

DTV

REF 4750-4799

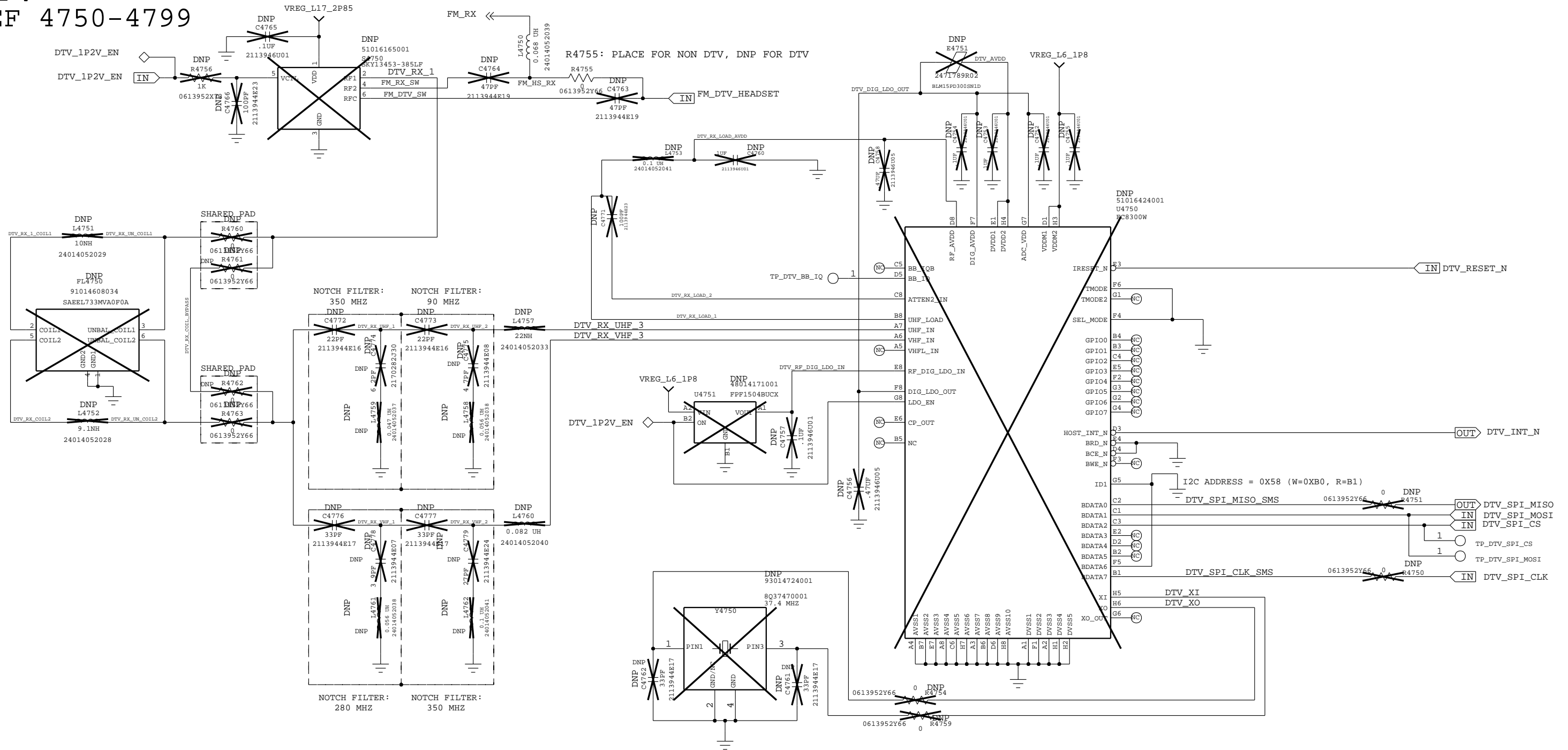

APPROVALS

ENGINEER :

LAST MODIFIED BY: GSHIMON
Mon May 11 16:30:21 2015

MOTOROLA CONFIDENTIAL RESTRICTED

THE DRAWING ON THIS PRINT AND INFORMATION
THEREWITH ARE PROPRIETARY TO MOTOROLA AND
SHALL NOT BE USED OR DISCUSSED IN WHOLE
OR IN PART WITHOUT MOTOROLA'S CONSENT.
© COPYRIGHT, MOTOROLA. THIS DOES
NOT IMPLY PUBLICATION



BLOCK TITLE:

connectivity

PROJECT NAME
B 84016407.cpm

CAD FILE NAME:

REV
01

XMCS: POWER

REF 6000-6999

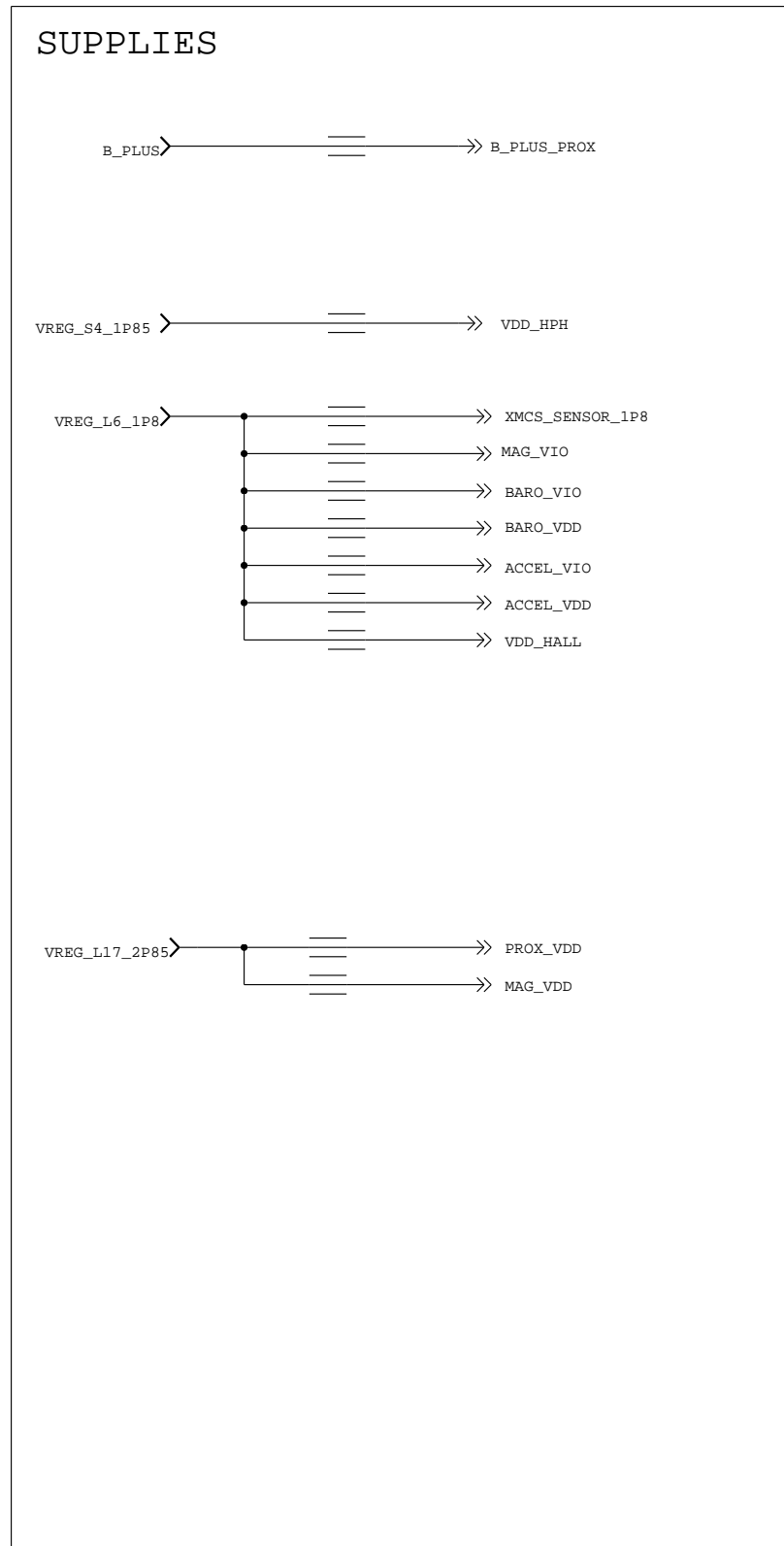

APPROVALS		MOTOROLA MOBILE DEVICES	
ENGINEER: NATE CONNELL		BLOCK TITLE:	
LAST MODIFIED BY: NATE CONNELL Tue Apr 28 15:20:31 2015		xmcs	
MOTOROLA CONFIDENTIAL RESTRICTED <small>THE DRAWING ON THIS PRINT AND INFORMATION THEREWITH ARE PROPRIETARY TO MOTOROLA AND SHALL NOT BE USED OR DISCUSSED IN WHOLE OR IN PART WITHOUT MOTOROLA'S CONSENT. © COPYRIGHT, MOTOROLA. THIS DOES NOT IMPLY PUBLICATION</small>		PROJECT NAME B 84016407.cpm	REV 01
		CAD FILE NAME:	
		PAGE 7 OF 47	

XMCS : PORTS

REF 6000-6999

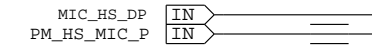
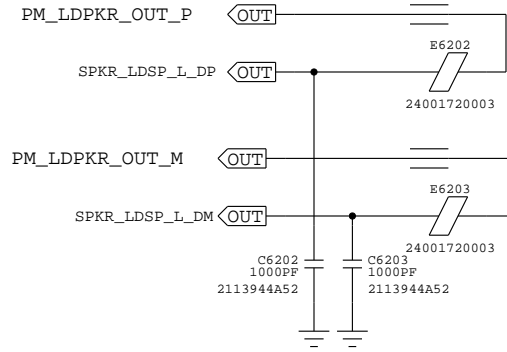
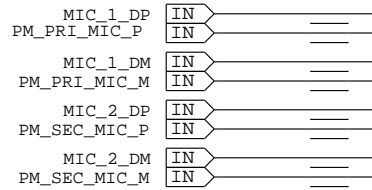
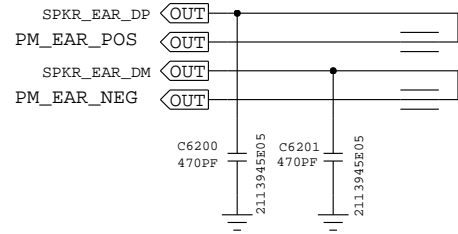
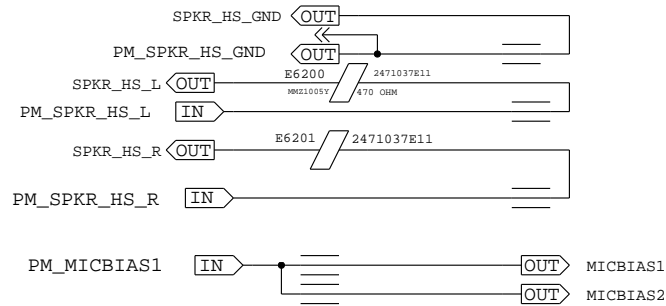
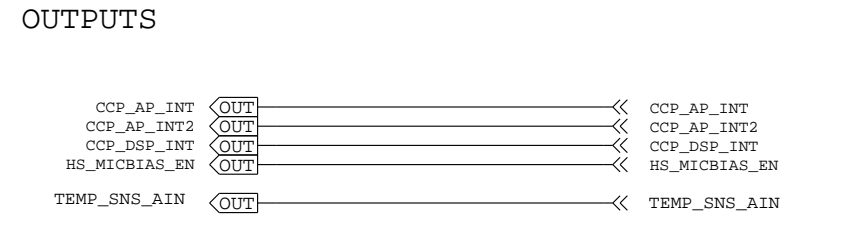
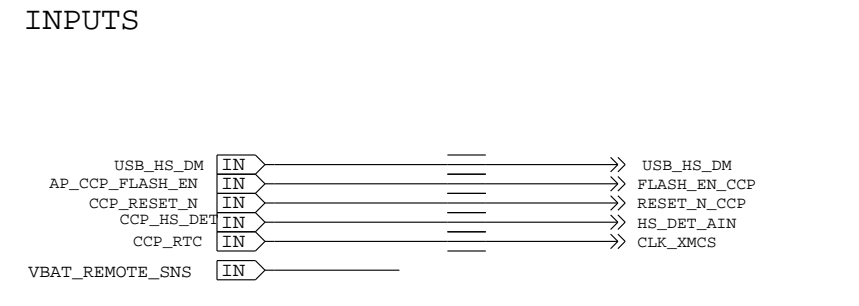
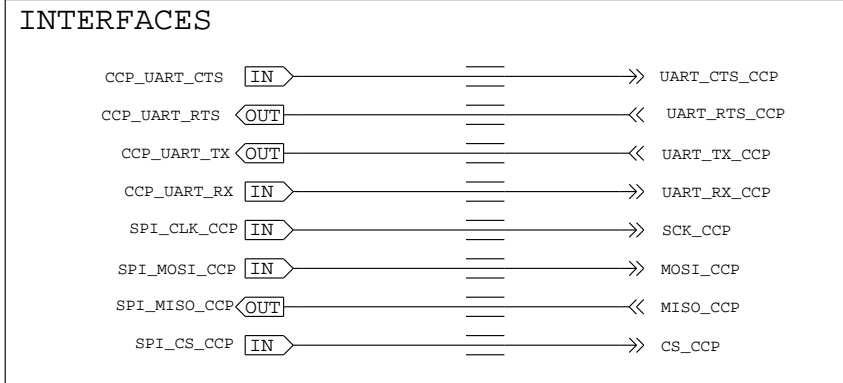

APPROVALS		MOTOROLA MOBILE DEVICES	
ENGINEER: RAUL LOPEZ		BLOCK TITLE:	
LAST MODIFIED BY: NATE CONNELL Mon May 11 16:30:26 2015		xmcs	
MOTOROLA CONFIDENTIAL RESTRICTED <small>THE DRAWING ON THIS PRINT AND INFORMATION THEREWITH ARE PROPRIETARY TO MOTOROLA AND SHALL NOT BE USED OR DISCUSSED IN WHOLE OR IN PART WITHOUT MOTOROLA'S CONSENT. © COPYRIGHT, MOTOROLA. THIS DOES NOT IMPLY PUBLICATION</small>		PROJECT NAME B 84016407.cpm	REV 01
		CAD FILE NAME:	
		PAGE 8 OF 47	

XMCS: CCP

REF: 6000-6049

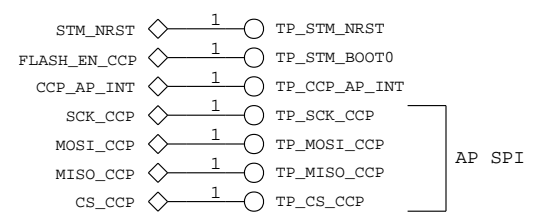
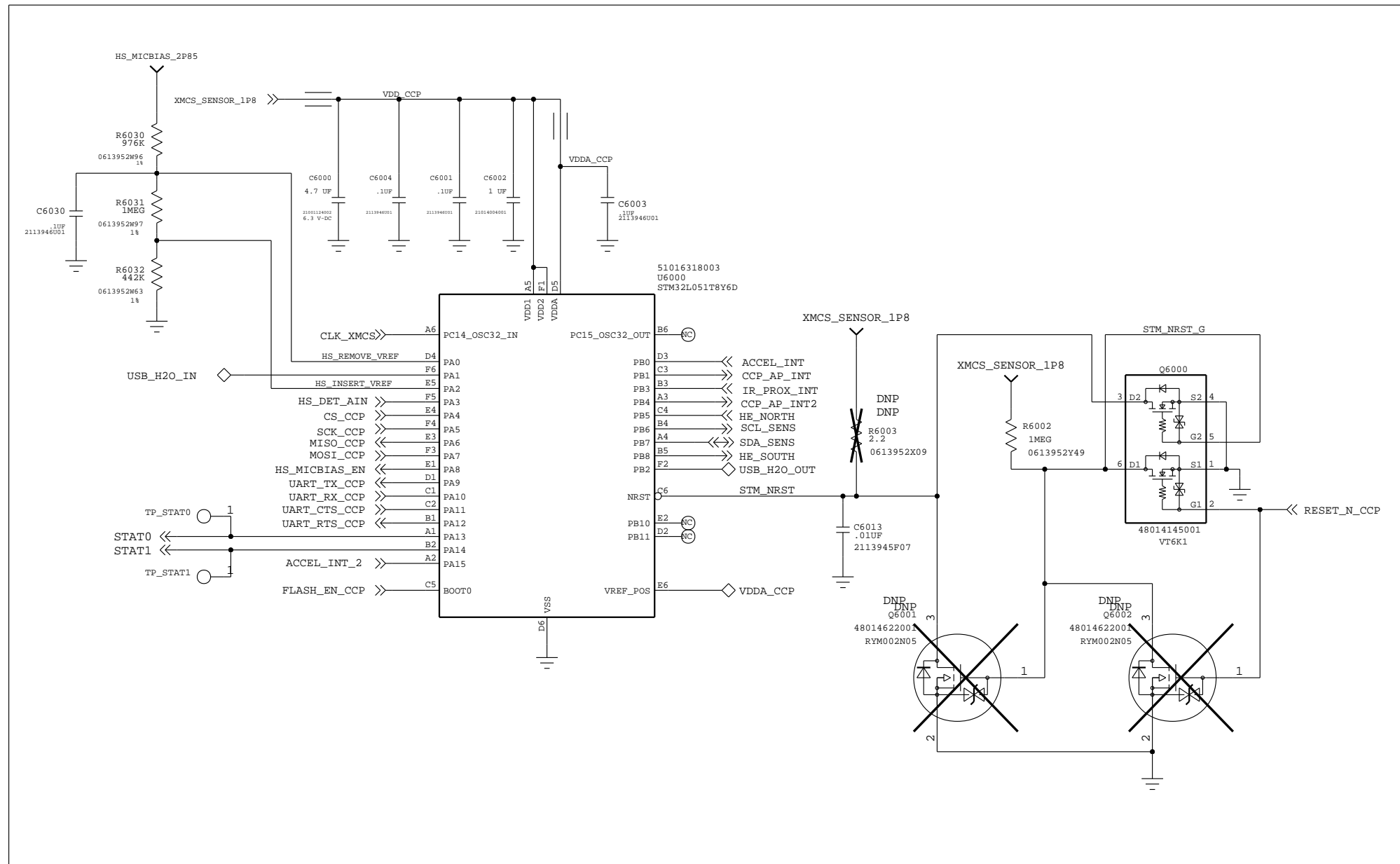

APPROVALS		MOTOROLA MOBILE DEVICES	
ENGINEER: JOHN GORSICA		BLOCK TITLE:	
LAST MODIFIED BY: NATE CONNELL Mon May 11 16:30:24 2015		xmcs	
MOTOROLA CONFIDENTIAL RESTRICTED		PROJECT NAME	REV
THE DRAWING ON THIS PRINT AND INFORMATION THEREWITH ARE PROPRIETARY TO MOTOROLA AND SHALL NOT BE USED OR DISCUSSED IN WHOLE OR IN PART WITHOUT MOTOROLA'S CONSENT. © COPYRIGHT, MOTOROLA. THIS DOES NOT IMPLY PUBLICATION		B 84016407.cpm	01
		CAD FILE NAME:	
		PAGE 9 OF 47	

SENSORS

REF: 6100-6199

PROX SENSOR/ALS INTERFACE

REF: 6190-6199
I2C ADDR: 0X39

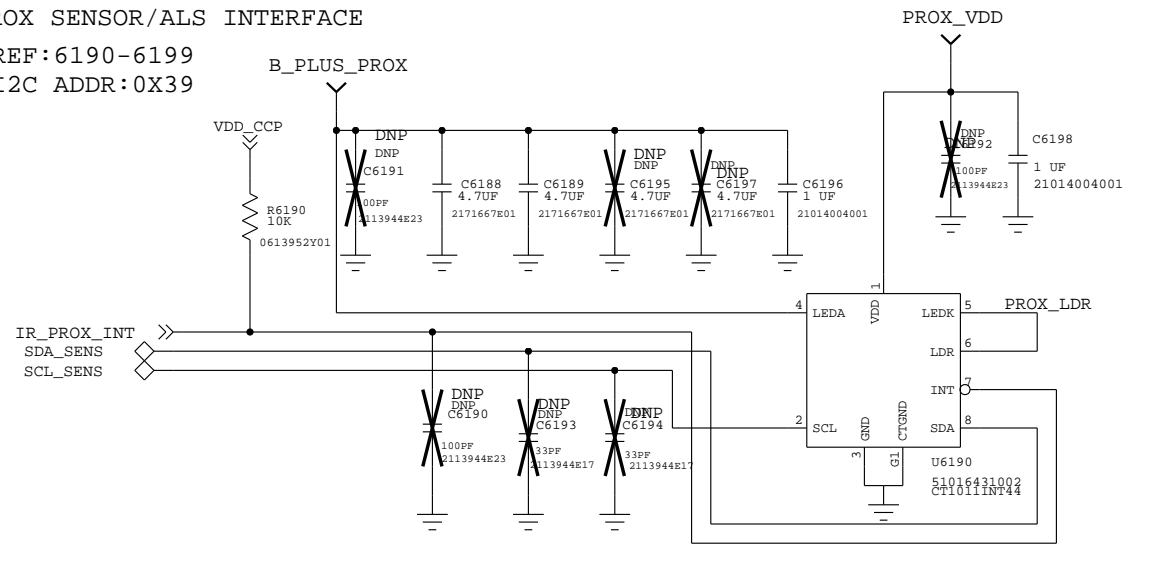

BOARD TEMP SENSOR

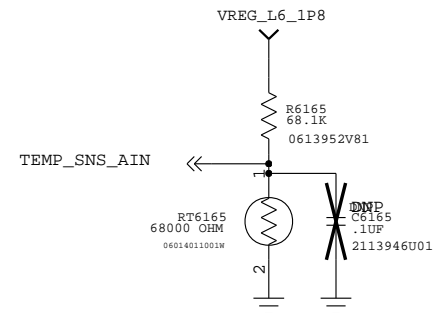

MAGNETOMETER

REF: 6160-6169

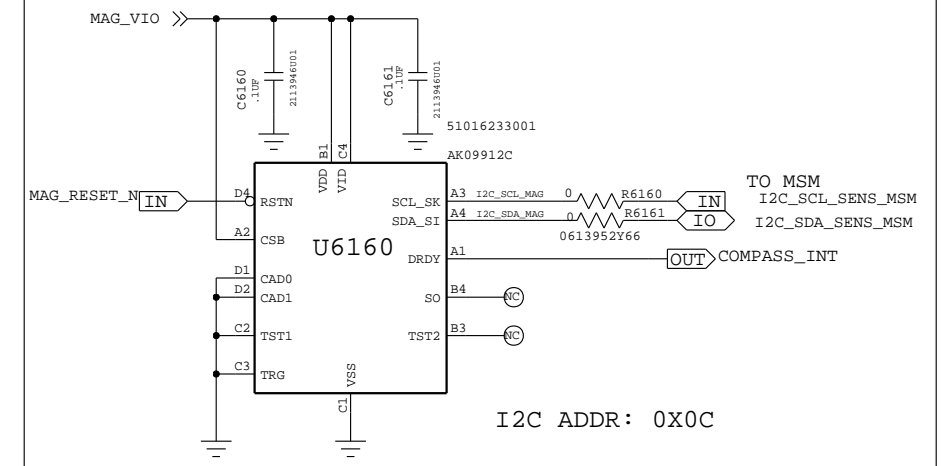

ACCELEROMETER

REF: 9710-9719

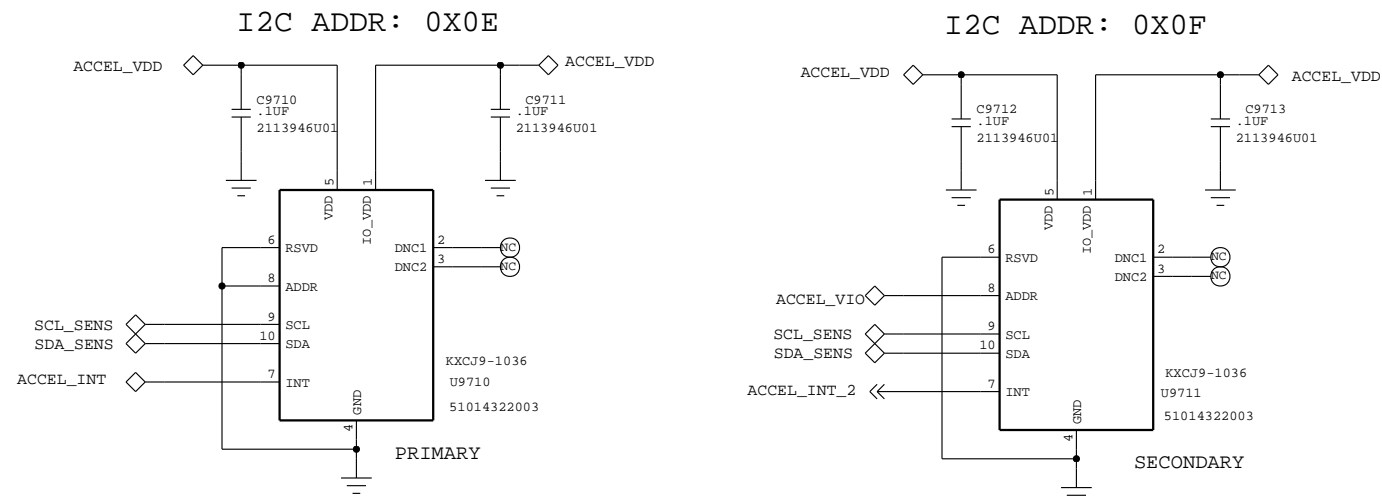

HALL EFFECT

REF: 6170-6179

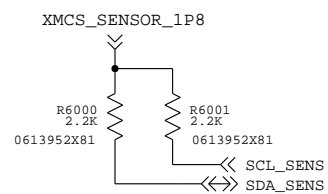
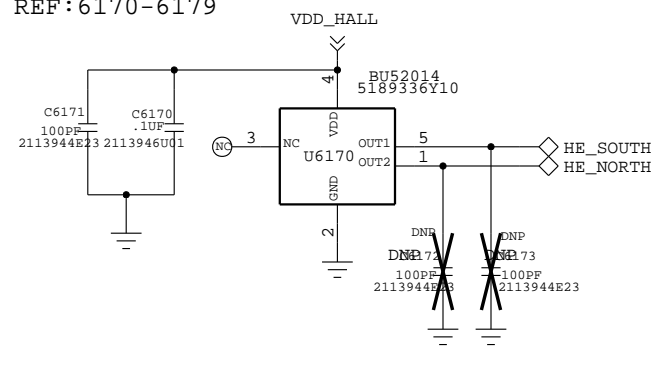

JOHN GORSICA/NATE CONNELL
APPROVALS



ENGINEER: C HERNANDEZ

BLOCK TITLE:

LAST MODIFIED BY: C HERNANDEZ

xmcs

Mon May 11 16:30:25 2015

MOTOROLA CONFIDENTIAL RESTRICTED

B

PROJECT NAME
84016407.APRAGOOCHIE

REV
01

THE DRAWING ON THIS PRINT AND INFORMATION
THEREWITH ARE PROPRIETARY TO MOTOROLA AND
SHALL NOT BE USED OR DISCUSSED IN WHOLE
OR IN PART WITHOUT MOTOROLA'S CONSENT.
© COPYRIGHT, MOTOROLA. THIS DOES
NOT IMPLY PUBLICATION

CAD FILE NAME:

PAGE 10 OF 47

MSM: POWER

REF: 1000-1999

SUPPLIES

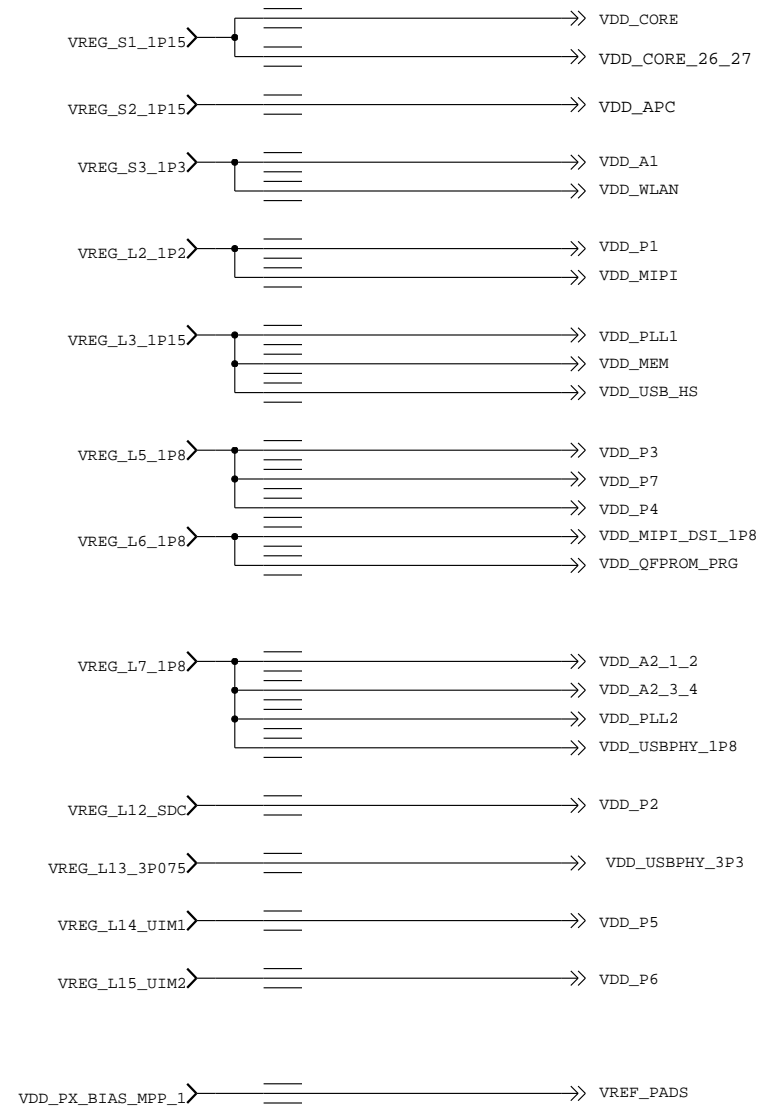

APPROVALS

ENGINEER: NATE CONNELL

LAST MODIFIED BY: NATE CONNELL
Tue Apr 28 15:20:20 2015

MOTOROLA CONFIDENTIAL RESTRICTED

THE DRAWING ON THIS PRINT AND INFORMATION
THEREWITH ARE PROPRIETARY TO MOTOROLA AND
SHALL NOT BE USED OR DISCUSSED IN WHOLE
OR IN PART WITHOUT MOTOROLA'S CONSENT.
© COPYRIGHT, MOTOROLA. THIS DOES
NOT IMPLY PUBLICATION



BLOCK TITLE:

ap_pmic

PROJECT NAME
B 84016407.cpm

REV
01

CAD FILE NAME:

PAGE 11 OF 47

MSM: CTRL

REF 1000-1099

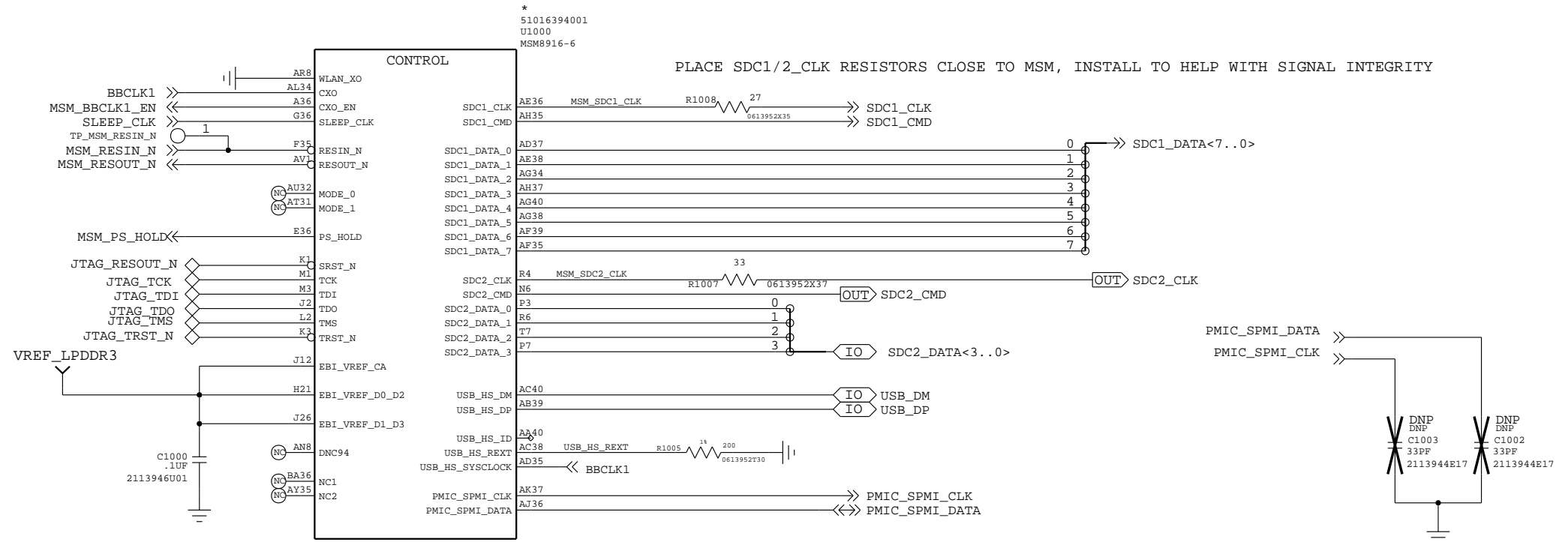

JTAG:MINI

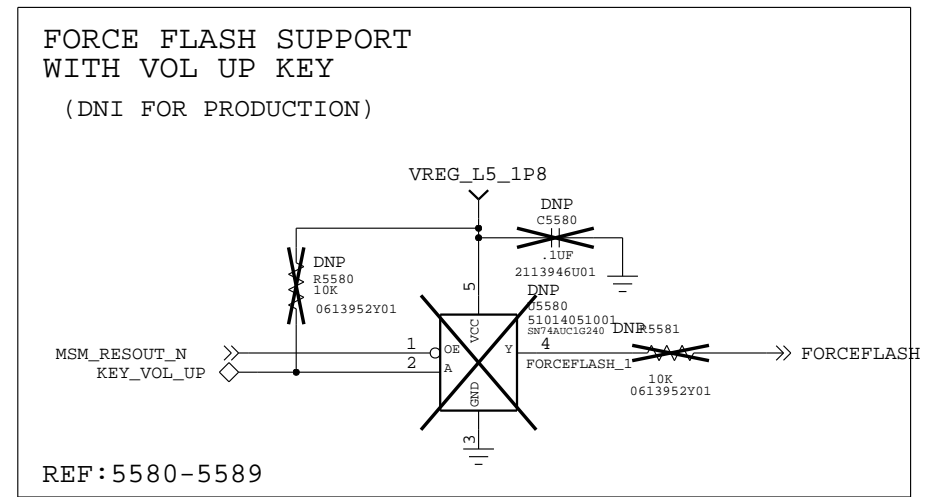
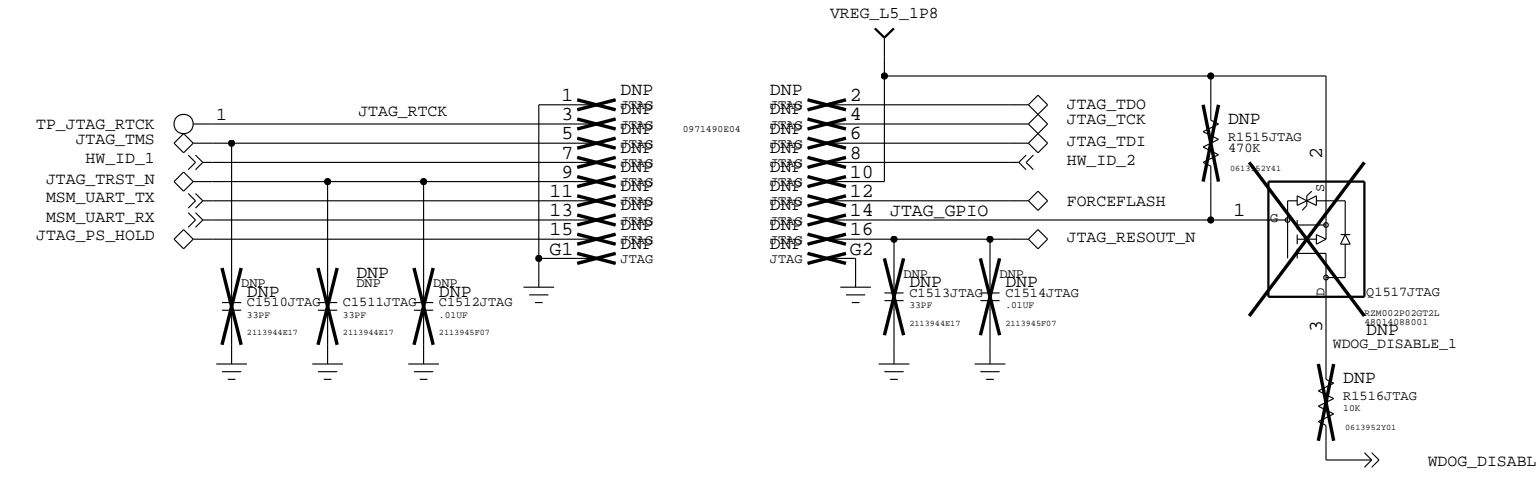

APPROVALS		MOTOROLA MOBILE DEVICES	
ENGINEER :		BLOCK TITLE :	
LAST MODIFIED BY: FAN021 Mon May 11 16:30:28 2015		ap_pmic	
MOTOROLA CONFIDENTIAL RESTRICTED <small>THE DRAWING ON THIS PRINT AND INFORMATION THEREWITH ARE PROPRIETARY TO MOTOROLA AND SHALL NOT BE USED OR DISCUSSED IN WHOLE OR IN PART WITHOUT MOTOROLA'S CONSENT. © COPYRIGHT, MOTOROLA. THIS DOES NOT IMPLY PUBLICATION</small>		PROJECT NAME	REV
		B 84016407.cpm	01
CAD FILE NAME :		PAGE 12 OF 47	

MSM: MIPI/DSI/CSI/EBIO

REF 1200-1299

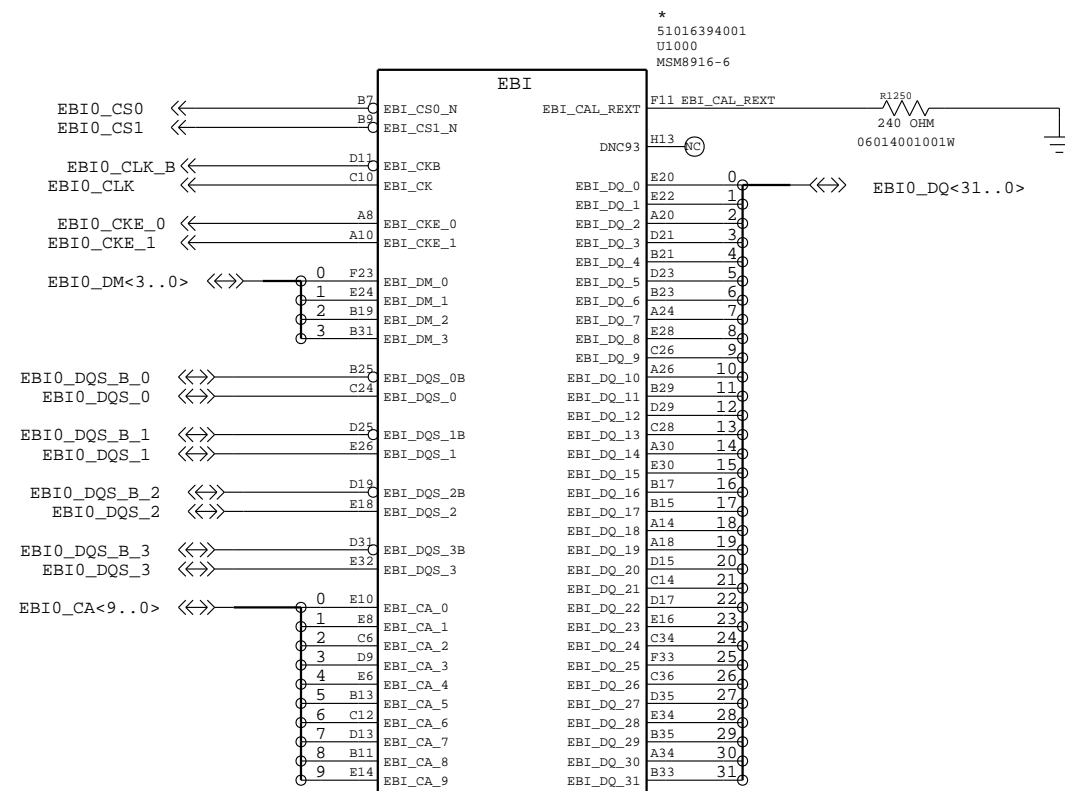
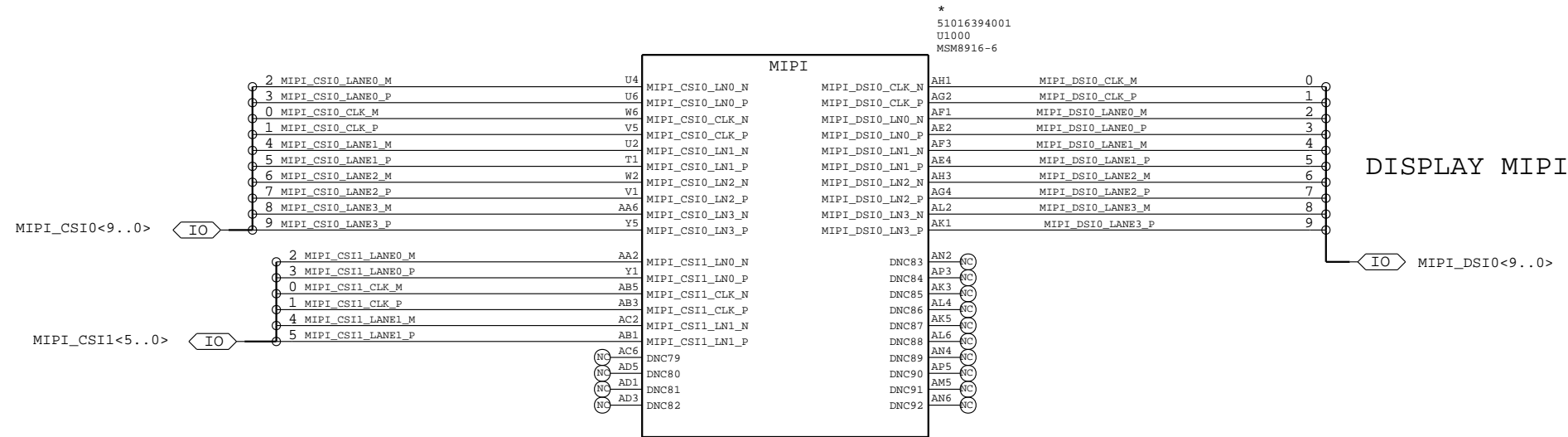

APPROVALS			
ENGINEER :		BLOCK TITLE :	
LAST MODIFIED BY :		ap_pmic	
Mon May 11 16:30:40 2015			
MOTOROLA CONFIDENTIAL RESTRICTED		PROJECT NAME	
THE DRAWING ON THIS PRINT AND INFORMATION THEREWITH ARE PROPRIETARY TO MOTOROLA AND SHALL NOT BE USED OR DISCUSSED IN WHOLE OR IN PART WITHOUT MOTOROLA'S CONSENT. © COPYRIGHT, MOTOROLA. THIS DOES NOT IMPLY PUBLICATION		84016407.cpm	
		REV 01	
		CAD FILE NAME :	
		PAGE 13 OF 47	

MSM: GPIO (0-101)

REF 1200-1299

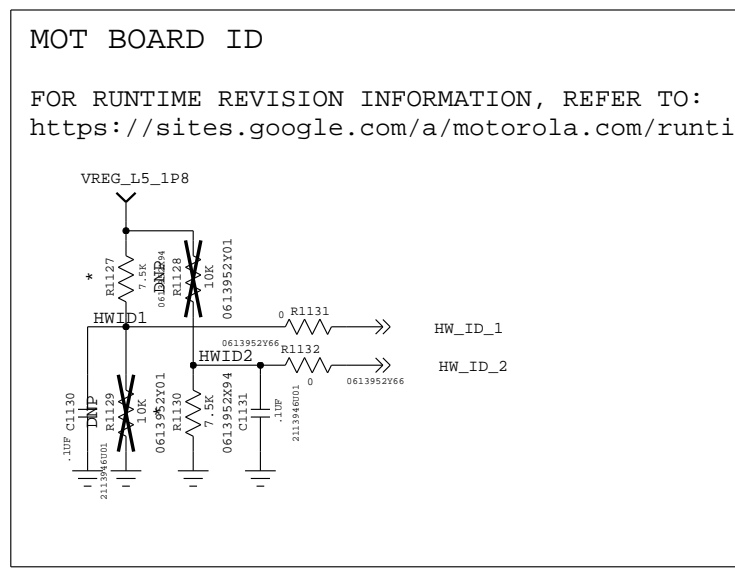
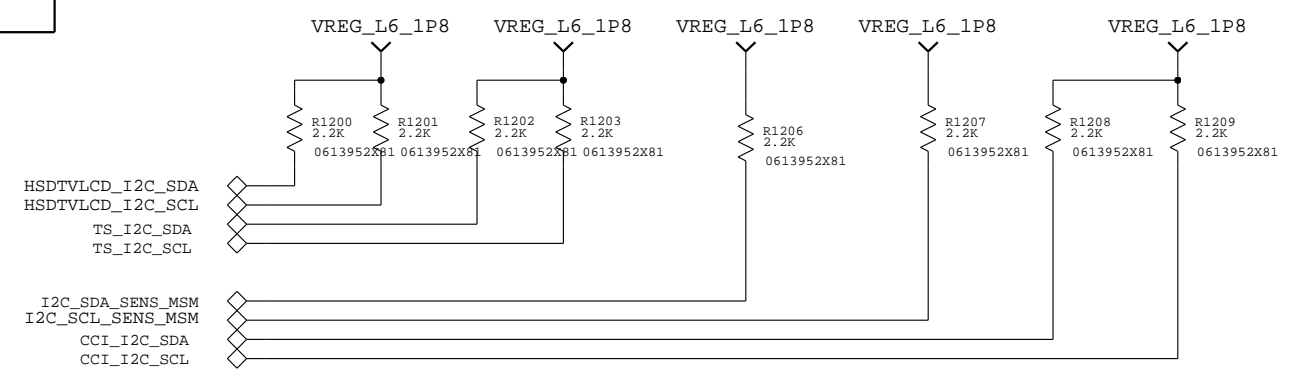
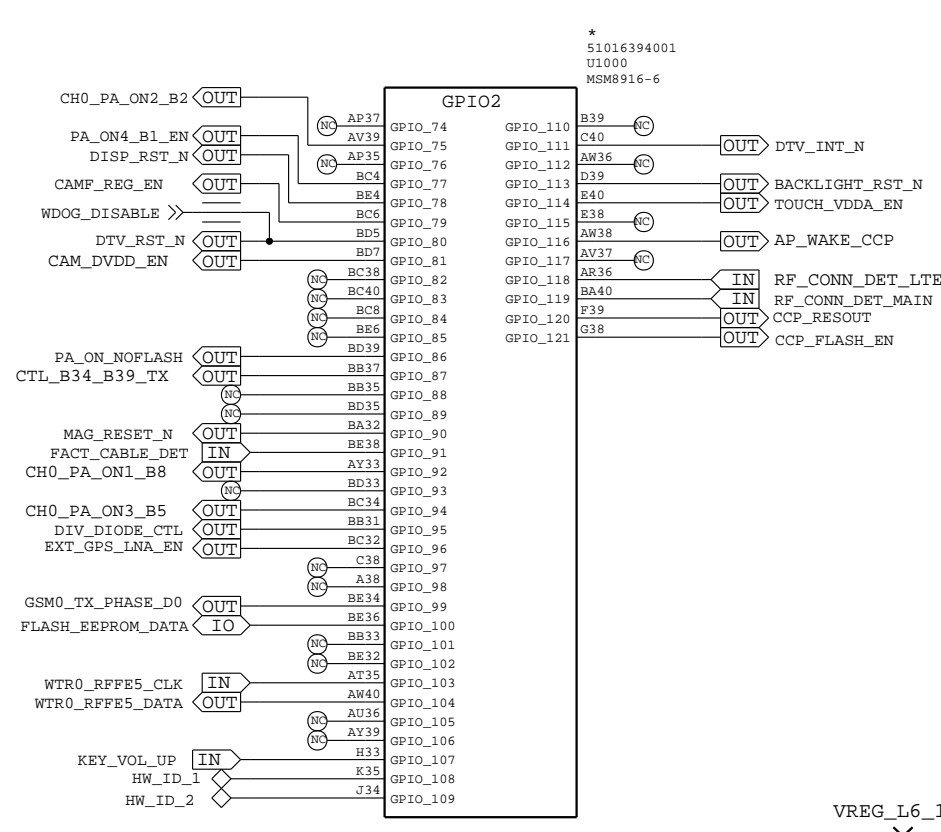
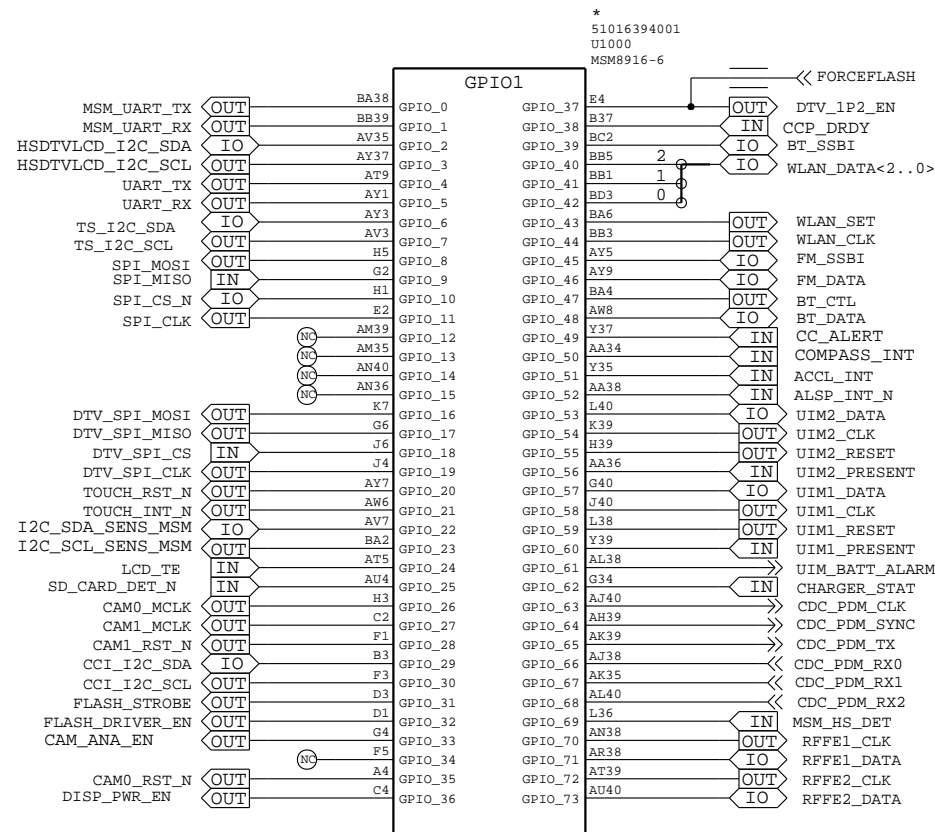

MOT BOARD ID
 FOR RUNTIME REVISION INFORMATION, REFER TO:
<https://sites.google.com/a/motorola.com/runtime-product-ids>

APPROVALS		MOTOROLA MOBILE DEVICES	
ENGINEER:		BLOCK TITLE:	
LAST MODIFIED BY: FAN021 Mon May 11 16:30:30 2015		ap_pmic	
MOTOROLA CONFIDENTIAL RESTRICTED		PROJECT NAME	REV
THE DRAWING ON THIS PRINT AND INFORMATION THEREWITH ARE PROPRIETARY TO MOTOROLA AND SHALL NOT BE USED OR DISCUSSED IN WHOLE OR IN PART WITHOUT MOTOROLA'S CONSENT. © COPYRIGHT, MOTOROLA. THIS DOES NOT IMPLY PUBLICATION		B 84016407.cpm	01
		CAD FILE NAME:	
		PAGE 14 OF 47	

MSM: PWR1

REF 1300-1399

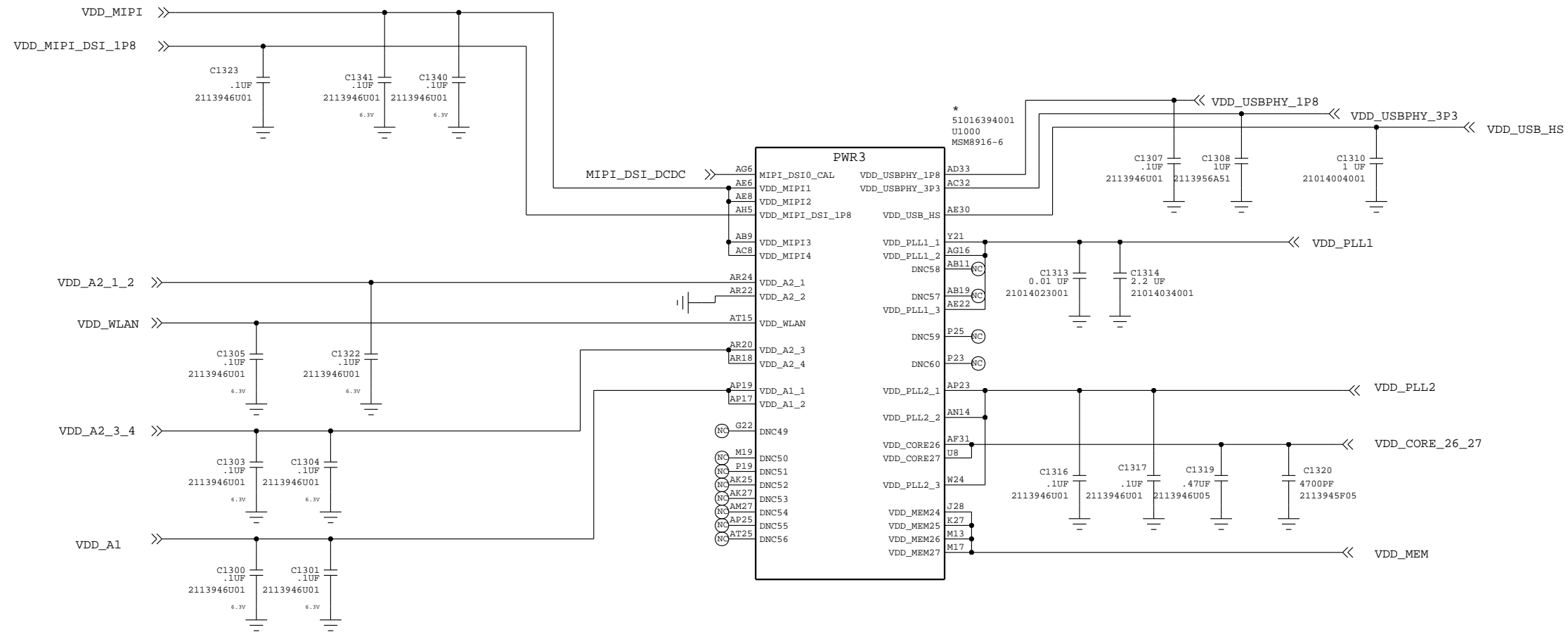

APPROVALS		MOTOROLA MOBILE DEVICES	
ENGINEER :		BLOCK TITLE :	
LAST MODIFIED BY: FAN021 Mon May 11 16:30:32 2015		ap_pmic	
MOTOROLA CONFIDENTIAL RESTRICTED <small>THE DRAWING ON THIS PRINT AND INFORMATION THEREWITH ARE PROPRIETARY TO MOTOROLA AND SHALL NOT BE USED OR DISCUSSED IN WHOLE OR IN PART WITHOUT MOTOROLA'S CONSENT. © COPYRIGHT, MOTOROLA. THIS DOES NOT IMPLY PUBLICATION</small>		PROJECT NAME B 84016407.cpm	REV 01
		CAD FILE NAME :	
		PAGE 15 OF 47	

MSM: PWR2

REF 1300-1399

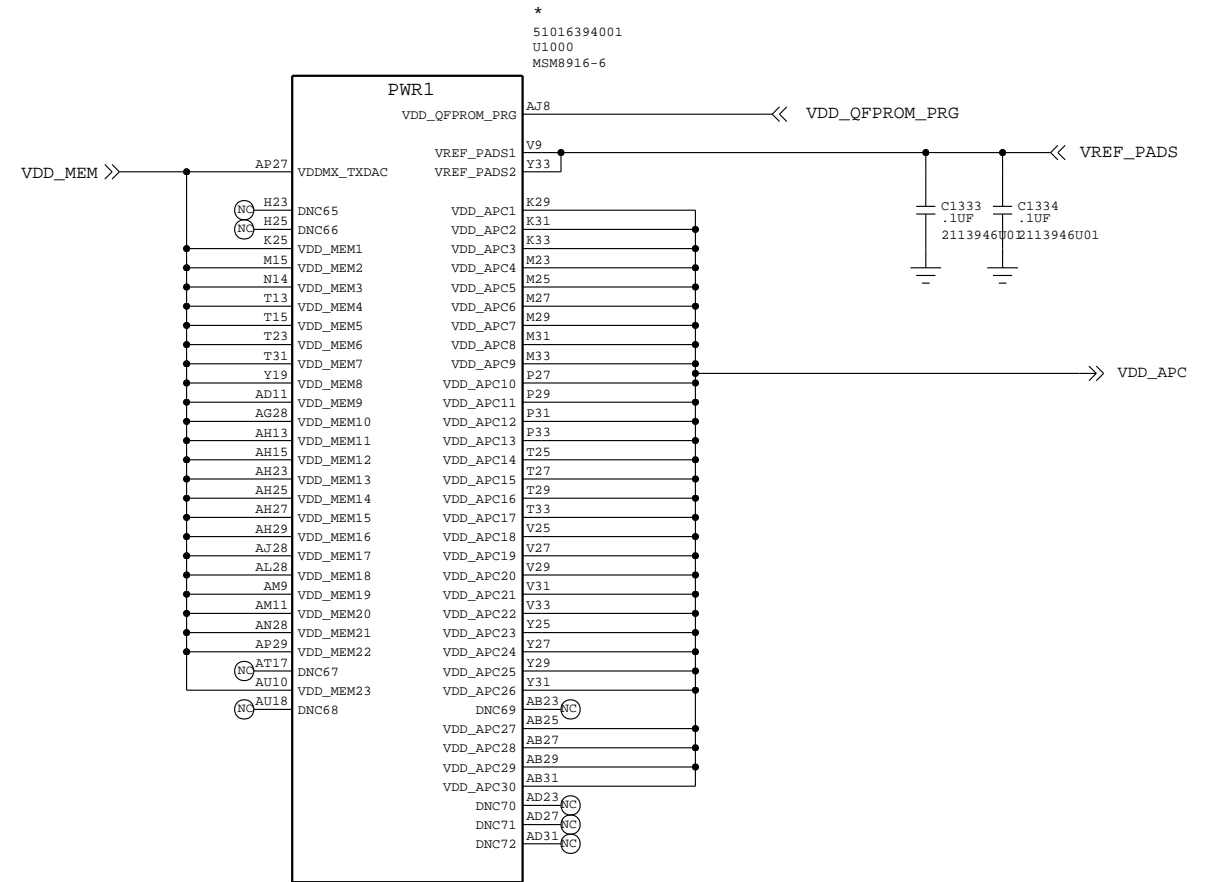
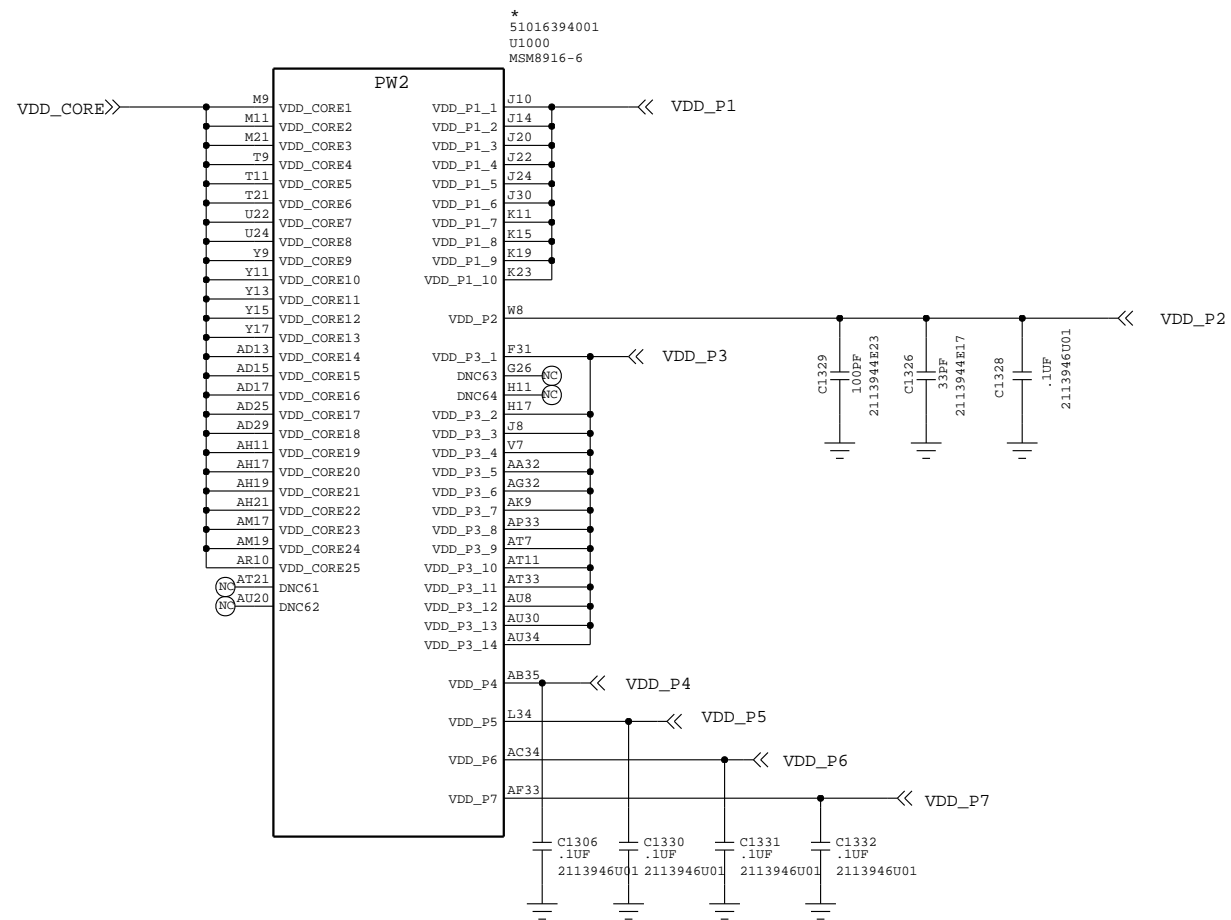

APPROVALS		MOTOROLA MOBILE DEVICES	
ENGINEER :		BLOCK TITLE :	
LAST MODIFIED BY: FAN021 Mon May 11 16:30:32 2015		ap_pmic	
MOTOROLA CONFIDENTIAL RESTRICTED <small>THE DRAWING ON THIS PRINT AND INFORMATION THEREWITH ARE PROPRIETARY TO MOTOROLA AND SHALL NOT BE USED OR DISCUSSED IN WHOLE OR IN PART WITHOUT MOTOROLA'S CONSENT. © COPYRIGHT, MOTOROLA. THIS DOES NOT IMPLY PUBLICATION</small>		PROJECT NAME 84016407.cpm	REV 01
		CAD FILE NAME :	
		PAGE 16 OF 47	

MSM: BYPASS CAPS

REF 1400-1499

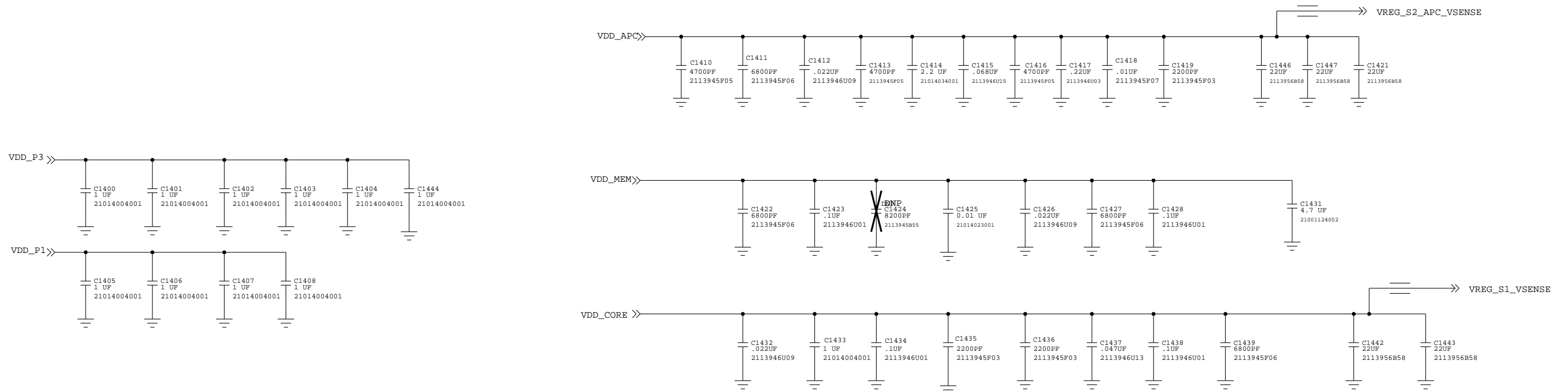

APPROVALS		MOTOROLA MOBILE DEVICES	
ENGINEER :		BLOCK TITLE :	
LAST MODIFIED BY: FAN021 Mon May 11 16:30:33 2015		ap_pmic	
MOTOROLA CONFIDENTIAL RESTRICTED <small>THE DRAWING ON THIS PRINT AND INFORMATION THEREWITH ARE PROPRIETARY TO MOTOROLA AND SHALL NOT BE USED OR DISCUSSED IN WHOLE OR IN PART WITHOUT MOTOROLA'S CONSENT. © COPYRIGHT, MOTOROLA. THIS DOES NOT IMPLY PUBLICATION</small>		PROJECT NAME B 84016407.cpm	REV 01
		CAD FILE NAME :	
		PAGE 17 OF 47	

MSM: GROUND

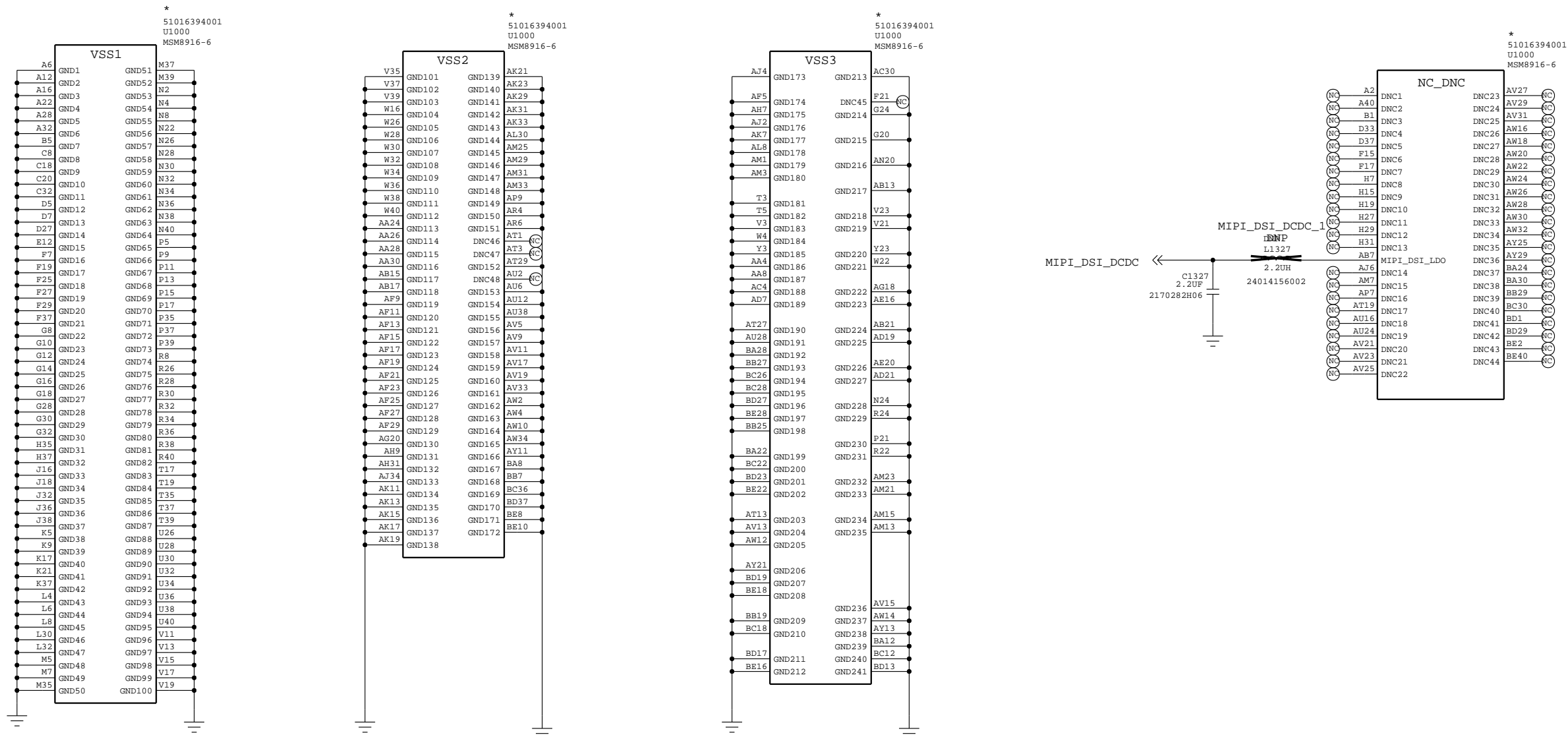

APPROVALS		MOTOROLA MOBILE DEVICES	
ENGINEER :		BLOCK TITLE :	
LAST MODIFIED BY: FAN021 Mon May 11 16:30:41 2015		ap_pmic	
MOTOROLA CONFIDENTIAL RESTRICTED <small>THE DRAWING ON THIS PRINT AND INFORMATION THEREWITH ARE PROPRIETARY TO MOTOROLA AND SHALL NOT BE USED OR DISCUSSED IN WHOLE OR IN PART WITHOUT MOTOROLA'S CONSENT. © COPYRIGHT, MOTOROLA. THIS DOES NOT IMPLY PUBLICATION</small>		PROJECT NAME B 84016407.cpm	REV 01
		CAD FILE NAME :	
		PAGE 18 OF 47	

MEMORY MCP

REF: 1600-1699

MCP: 8GB NAND, 8GBIT LPDDR3

REVISIONS				
REV	ECN	DESCRIPTION	MADE BY	APPROVED

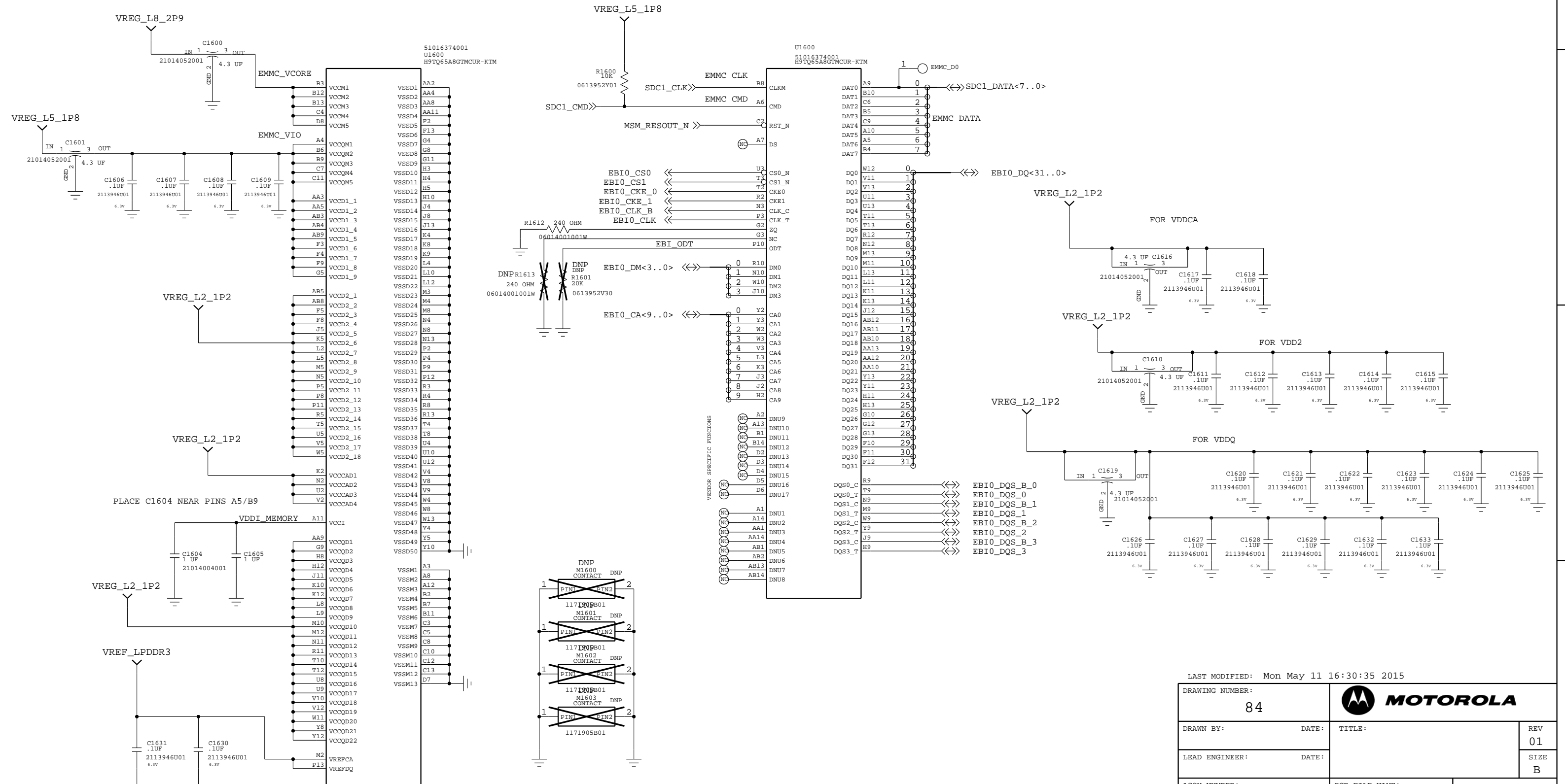

LAST MODIFIED: Mon May 11 16:30:35 2015

DRAWING NUMBER: 84			
DRAWN BY:	DATE:	TITLE:	REV 01
LEAD ENGINEER:	DATE:		SIZE B
ASSY NUMBER:	PCB FILE NAME:	PAGE 19 OF 47	

MOTOROLA CONFIDENTIAL RESTRICTED

PM8916: POWER

REF: 2000-2999

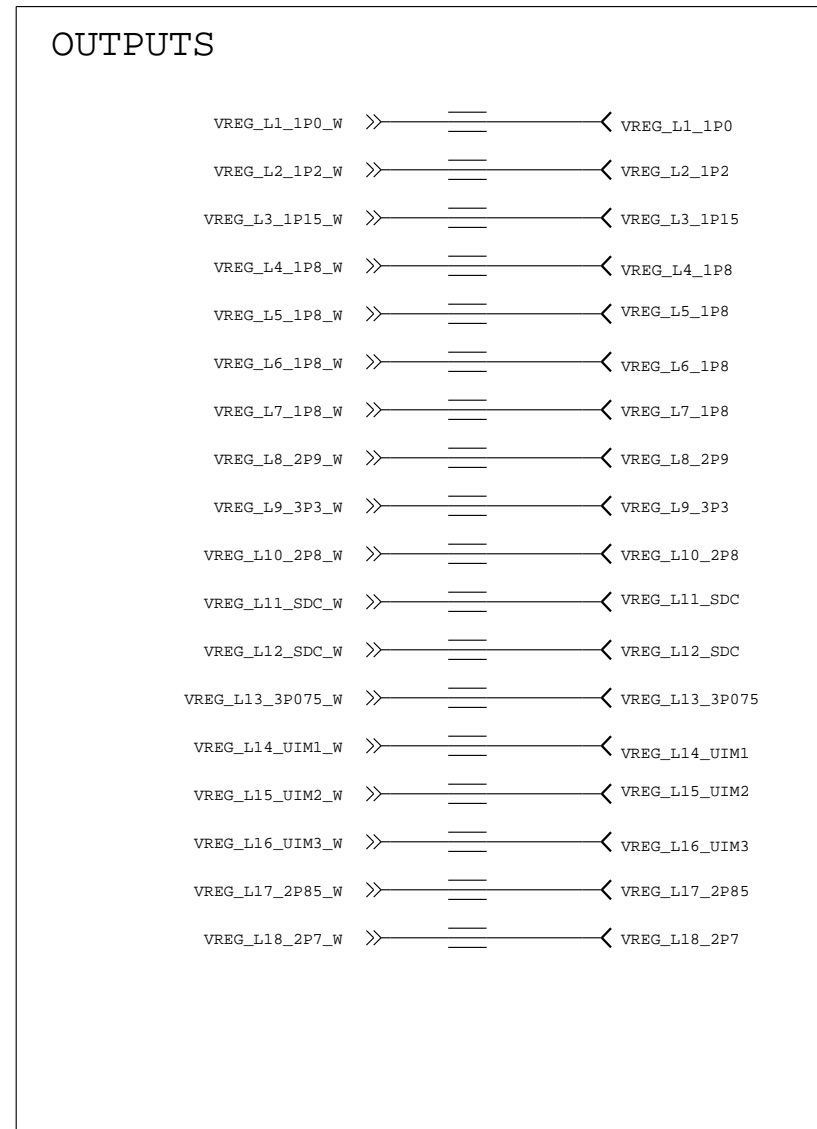
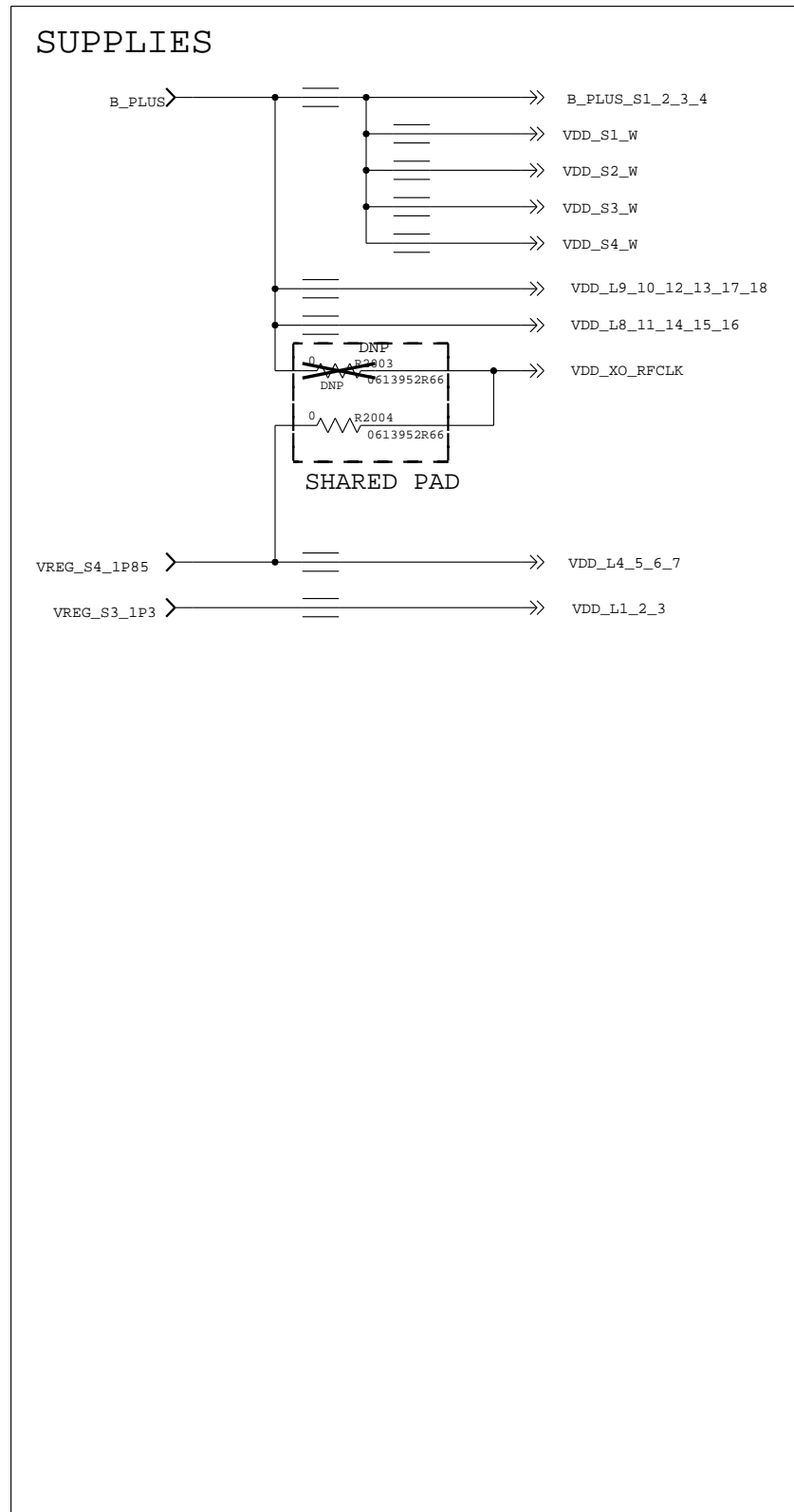

APPROVALS		MOTOROLA MOBILE DEVICES	
ENGINEER: NATE CONNELL		BLOCK TITLE:	
LAST MODIFIED BY: NATE CONNELL Mon May 11 16:30:39 2015		ap_pmic	
MOTOROLA CONFIDENTIAL RESTRICTED <small>THE DRAWING ON THIS PRINT AND INFORMATION THEREWITH ARE PROPRIETARY TO MOTOROLA AND SHALL NOT BE USED OR DISCUSSED IN WHOLE OR IN PART WITHOUT MOTOROLA'S CONSENT. © COPYRIGHT, MOTOROLA. THIS DOES NOT IMPLY PUBLICATION</small>		PROJECT NAME B 84016407.cpm	REV 01
		CAD FILE NAME:	
		PAGE 20 OF 47	

PM8916: HK

REF: 2000-2999

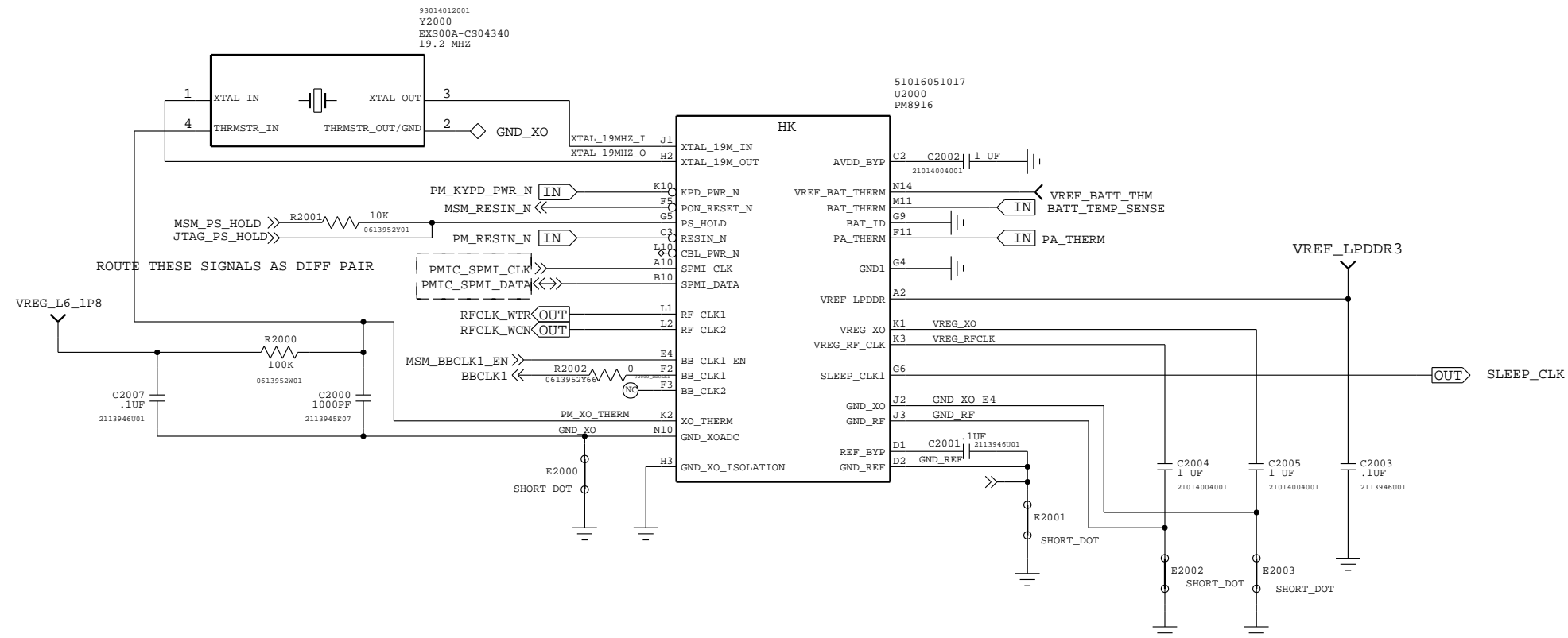

APPROVALS		MOTOROLA MOBILE DEVICES	
ENGINEER: XIAOYU WANG		BLOCK TITLE:	
LAST MODIFIED BY: MMI Mon May 11 16:30:29 2015		ap_pmic	
MOTOROLA CONFIDENTIAL RESTRICTED THE DRAWING ON THIS PRINT AND INFORMATION THEREWITH ARE PROPRIETARY TO MOTOROLA AND SHALL NOT BE USED OR DISCUSSED IN WHOLE OR IN PART WITHOUT MOTOROLA'S CONSENT. © COPYRIGHT, MOTOROLA. THIS DOES NOT IMPLY PUBLICATION		PROJECT NAME	REV
		B 84016407.cpm	01
		CAD FILE NAME:	
		PAGE 21 OF 47	

PM8916: CHRGE/LED/GPIO

REF: 2000-2999

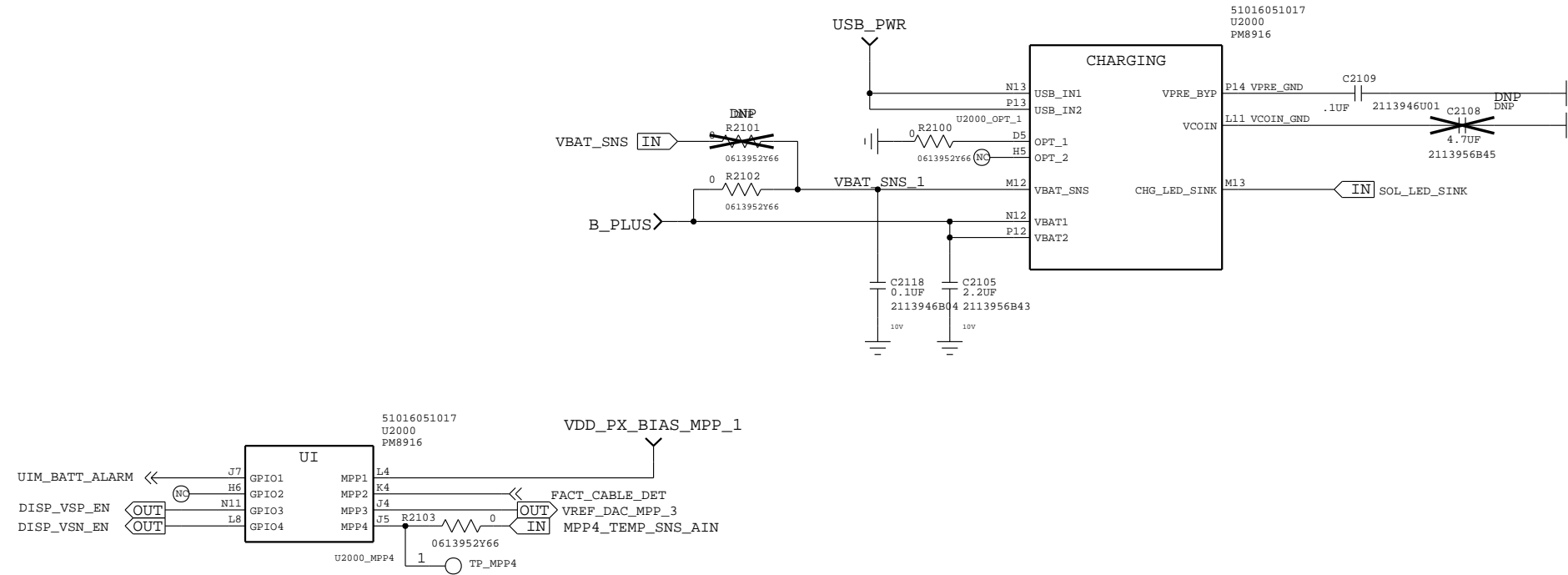

APPROVALS		MOTOROLA MOBILE DEVICES	
ENGINEER: MMI		BLOCK TITLE:	
LAST MODIFIED BY: MMI Mon May 11 16:30:37 2015		ap_pmic	
MOTOROLA CONFIDENTIAL RESTRICTED <small>THE DRAWING ON THIS PRINT AND INFORMATION THEREWITH ARE PROPRIETARY TO MOTOROLA AND SHALL NOT BE USED OR DISCUSSED IN WHOLE OR IN PART WITHOUT MOTOROLA'S CONSENT. © COPYRIGHT, MOTOROLA. THIS DOES NOT IMPLY PUBLICATION</small>		PROJECT NAME	REV
		B 84016407.cpm	01
		CAD FILE NAME:	
		PAGE 22 OF 47	

PM8916: SMPS

REF: 2000-2999

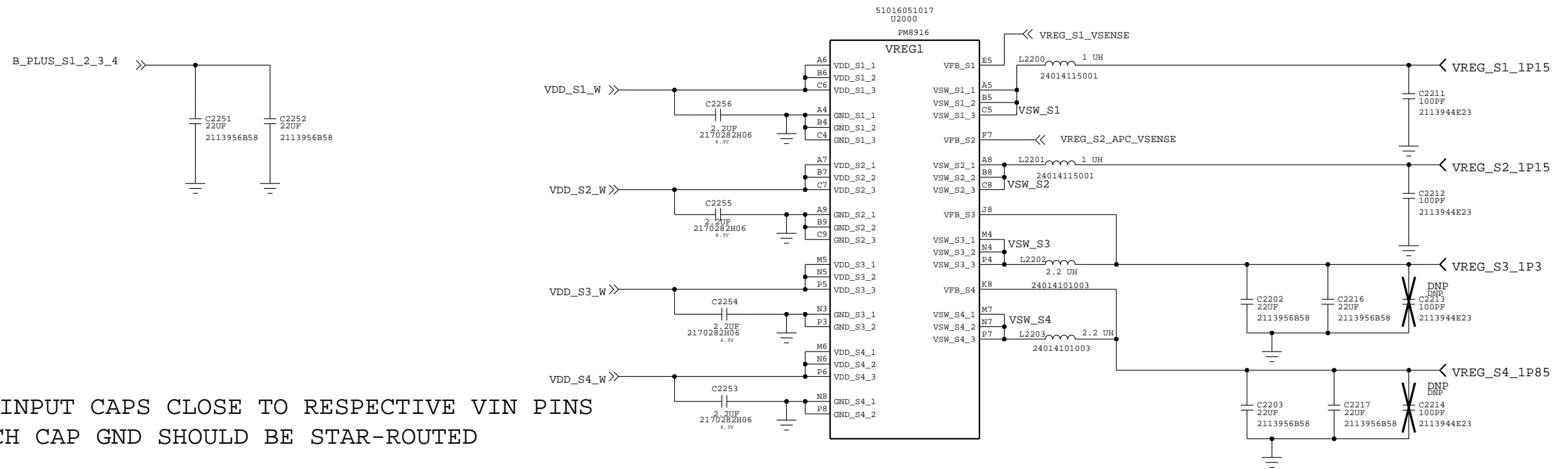

NOTE: PLACE INPUT CAPS CLOSE TO RESPECTIVE VIN PINS
EACH CAP GND SHOULD BE STAR-ROUTED

APPROVALS		MOTOROLA MOBILE DEVICES	
ENGINEER: XIAOYU WANG		BLOCK TITLE:	
LAST MODIFIED BY: MMI Mon May 11 16:30:37 2015		ap_pmic	
MOTOROLA CONFIDENTIAL RESTRICTED <small>THE DRAWING ON THIS PRINT AND INFORMATION THEREWITH ARE PROPRIETARY TO MOTOROLA AND SHALL NOT BE USED OR DISCUSSED IN WHOLE OR IN PART WITHOUT MOTOROLA'S CONSENT. © COPYRIGHT, MOTOROLA. THIS DOES NOT IMPLY PUBLICATION</small>		PROJECT NAME B 84016407.cpm	REV 01
		CAD FILE NAME:	
		PAGE 23 OF 47	

PM8916: VREGS

REF: 2000-2999

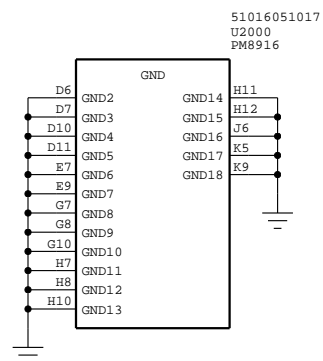
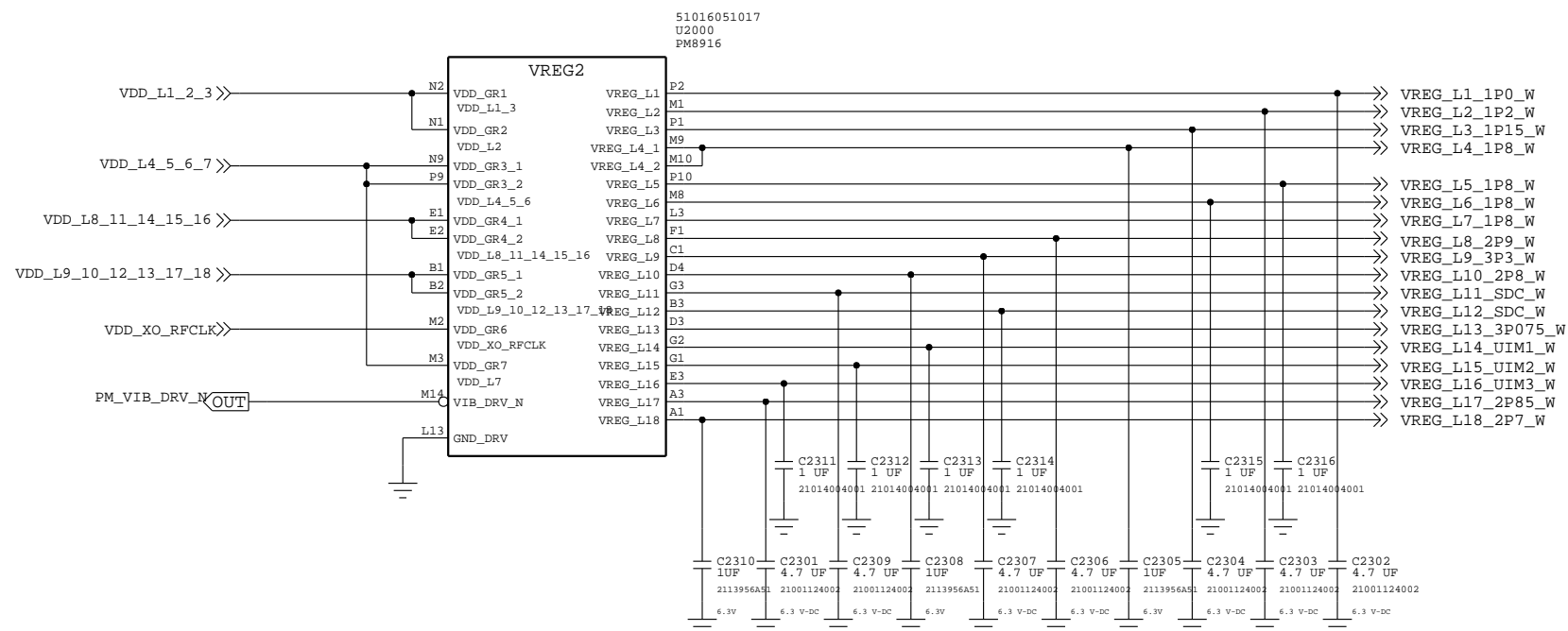

PSEUDO CAPLESS LDOS

L4, L5, L6, L7, L8, L9, L10, L11, L12, L13, L14, L15, L16, L17, L18

L8, L9, L11, L17 EACH SHALL HAVE TOTAL EFFECTIVE OUTPUT CAPACITANCE OF 4.7UF
 REST OF THE LDOS SHALL HAVE TOTAL EFFECTIVE OUTPUT CAPACITANCE OF 1.0UF

NOTE: IF A DECOUPLING CAP OF A PSEUDO CAPLESS LDO DOES NOT ADD TO 1UF ON THE LOAD SIDE, INSTALL THE CAP CLOSE TO THE PMIC

APPROVALS		MOTOROLA MOBILE DEVICES	
ENGINEER: XIAOYU WANG		BLOCK TITLE:	
LAST MODIFIED BY: MMI Mon May 11 16:30:38 2015		ap_pmic	
MOTOROLA CONFIDENTIAL RESTRICTED <small>THE DRAWING ON THIS PRINT AND INFORMATION THEREWITH ARE PROPRIETARY TO MOTOROLA AND SHALL NOT BE USED OR DISCUSSED IN WHOLE OR IN PART WITHOUT MOTOROLA'S CONSENT. © COPYRIGHT, MOTOROLA. THIS DOES NOT IMPLY PUBLICATION</small>		PROJECT NAME B 84016407.cpm	REV 01
		CAD FILE NAME:	
		PAGE 24 OF 47	

PM8916: CODEC

REF 2000-2999

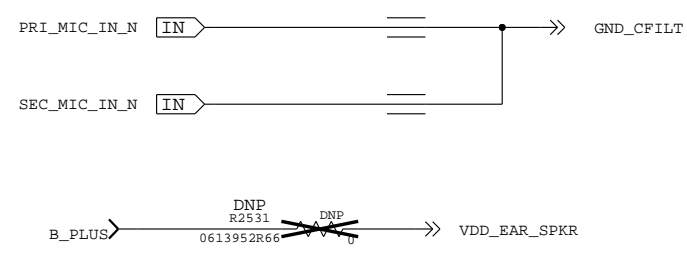
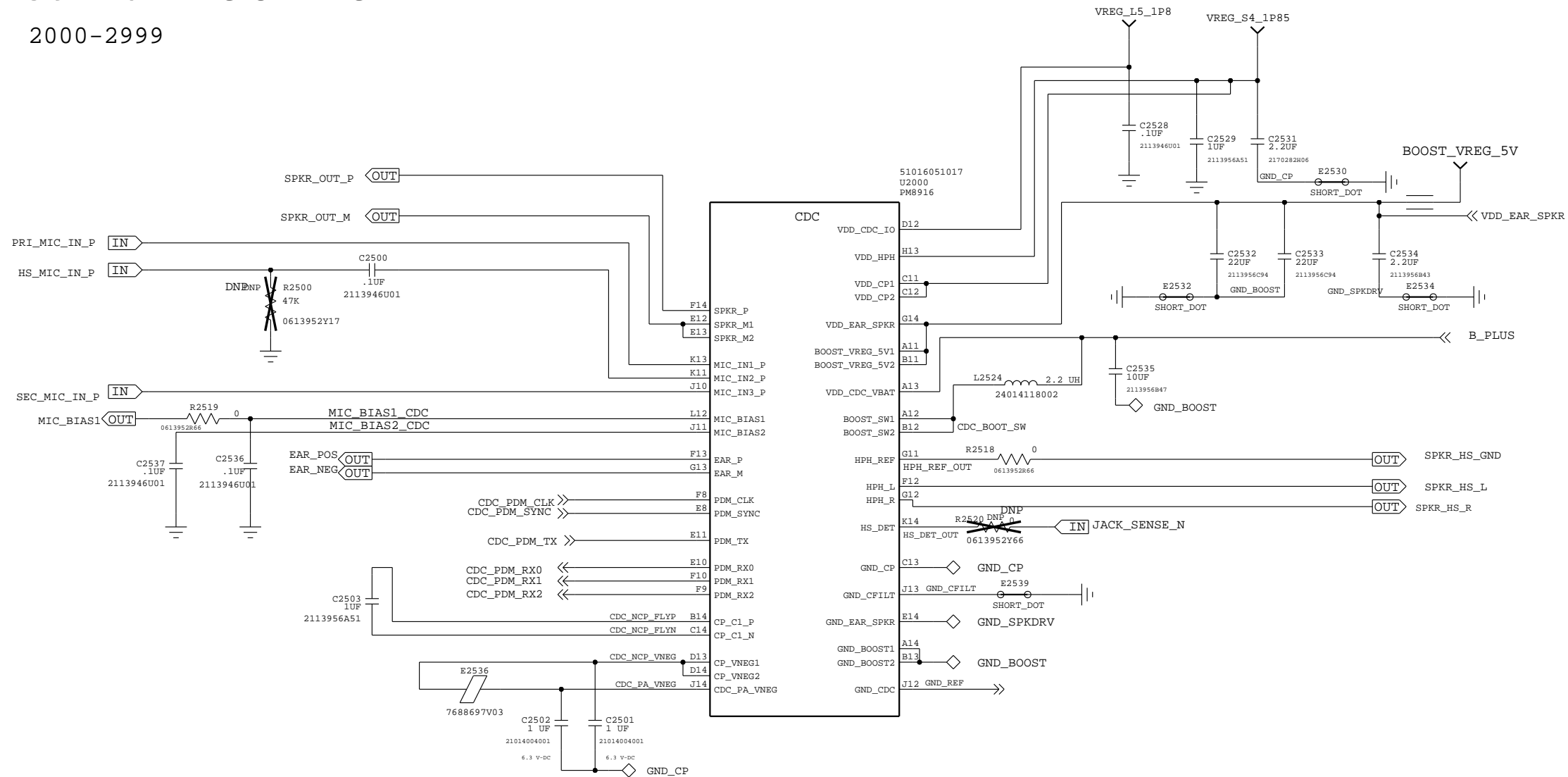

APPROVALS		MOTOROLA MOBILE DEVICES	
ENGINEER: XIAOYU WANG		BLOCK TITLE:	
LAST MODIFIED BY: ECB033 Mon May 11 16:30:29 2015		ap_pmic	
MOTOROLA CONFIDENTIAL RESTRICTED		PROJECT NAME	REV
<small>THE DRAWING ON THIS PRINT AND INFORMATION THEREWITH ARE PROPRIETARY TO MOTOROLA AND SHALL NOT BE USED OR DISCUSSED IN WHOLE OR IN PART WITHOUT MOTOROLA'S CONSENT. © COPYRIGHT, MOTOROLA. THIS DOES NOT IMPLY PUBLICATION</small>		B 84016407.cpm	01
		CAD FILE NAME:	
		PAGE 25 OF 47	

WTR4905 BB RF

REF 3000-3099

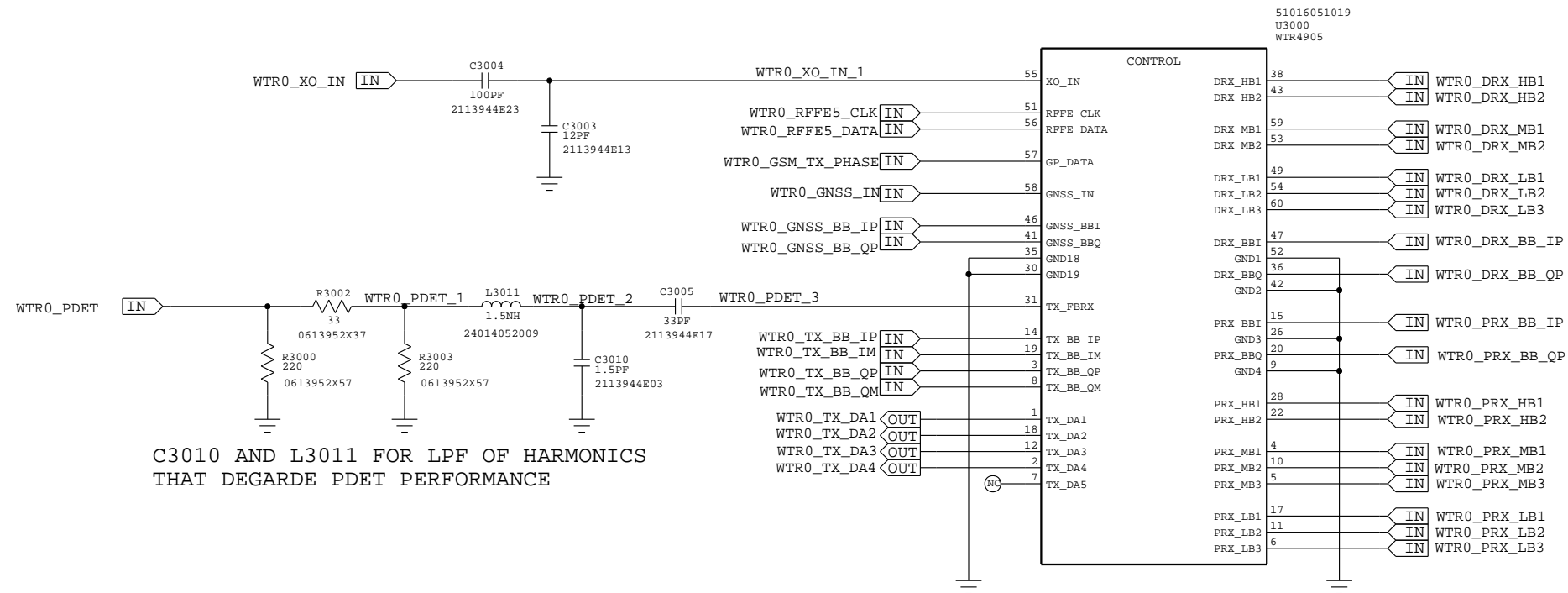

MOTOROLA MOBILITY CONFIDENTIAL RESTRICTED-MDB TRACKED TRACKEDANDBLOCKED

APPROVALS		 MOTOROLA MOBILE DEVICES	
ENGINEER: MMI		BLOCK TITLE:	
LAST MODIFIED BY: Mon May 11 16:30:43 2015		block_wtr4905	
MOTOROLA CONFIDENTIAL RESTRICTED		PROJECT NAME	REV
THE DRAWING ON THIS PRINT AND INFORMATION THEREWITH ARE PROPRIETARY TO MOTOROLA AND SHALL NOT BE USED OR DISCUSSED IN WHOLE OR IN PART WITHOUT MOTOROLA'S CONSENT. © COPYRIGHT, MOTOROLA. THIS DOES NOT IMPLY PUBLICATION		B 84016407.cpm	01
		CAD FILE NAME:	
		PAGE 26 OF 47	

BASED ON 80-NL713-44 REV. A

WTR4905 POWER
REF 3100-3199

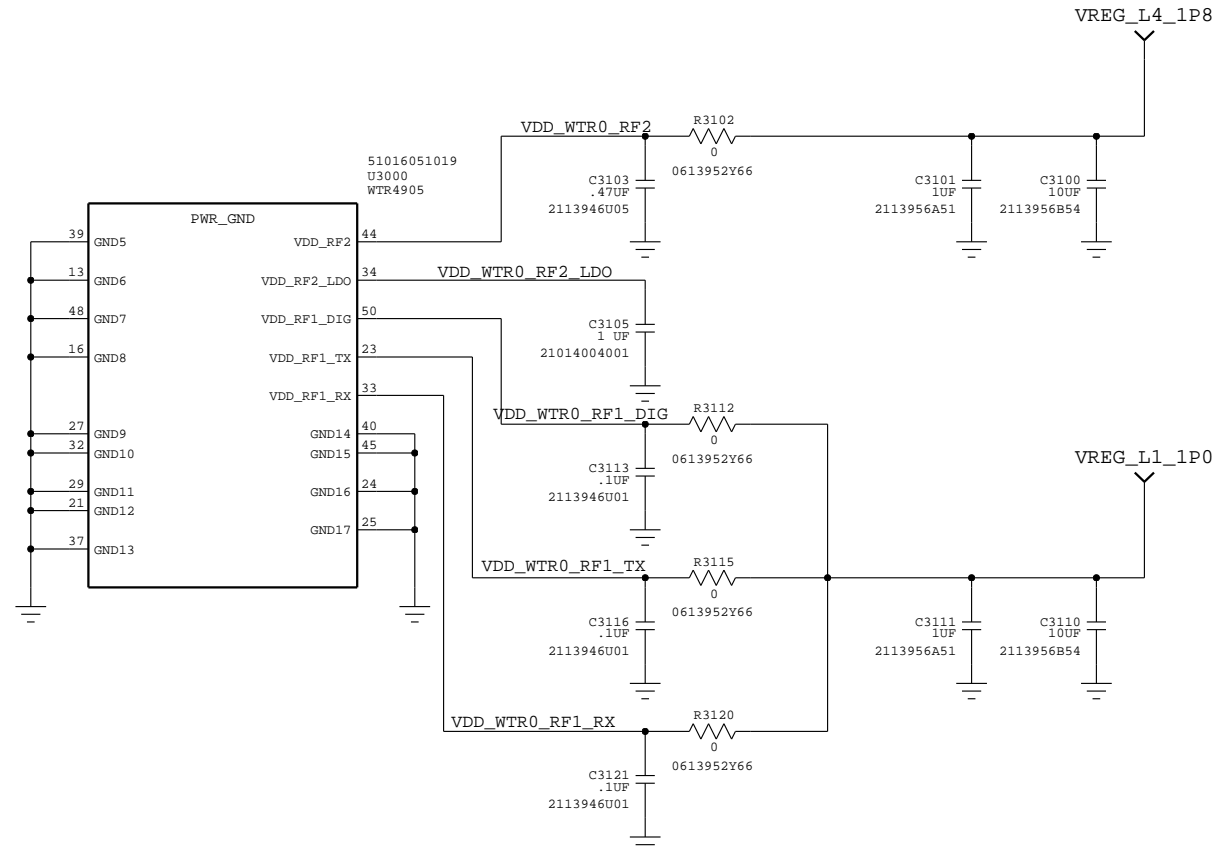

MOTOROLA MOBILITY CONFIDENTIAL RESTRICTED-MDB TRACKED TRACKEDANDBLOCKED

APPROVALS		MOTOROLA MOBILE DEVICES	
ENGINEER: MMI		BLOCK TITLE:	
LAST MODIFIED BY: MMI Mon May 11 16:30:44 2015		block_wtr4905	
MOTOROLA CONFIDENTIAL RESTRICTED <small>THE DRAWING ON THIS PRINT AND INFORMATION THEREWITH ARE PROPRIETARY TO MOTOROLA AND SHALL NOT BE USED OR DISCUSSED IN WHOLE OR IN PART WITHOUT MOTOROLA'S CONSENT. © COPYRIGHT, MOTOROLA. THIS DOES NOT IMPLY PUBLICATION</small>		PROJECT NAME B 84016407.cpm	REV 01
		CAD FILE NAME:	
		PAGE 27 OF 47	

BASED ON 80-NL713-44 REV. A

FRONT CAMERA

REF 5600-5649

FF CAMERA CONNECTOR

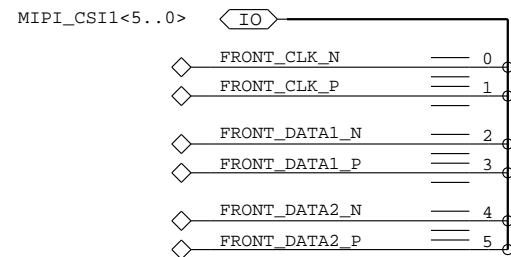
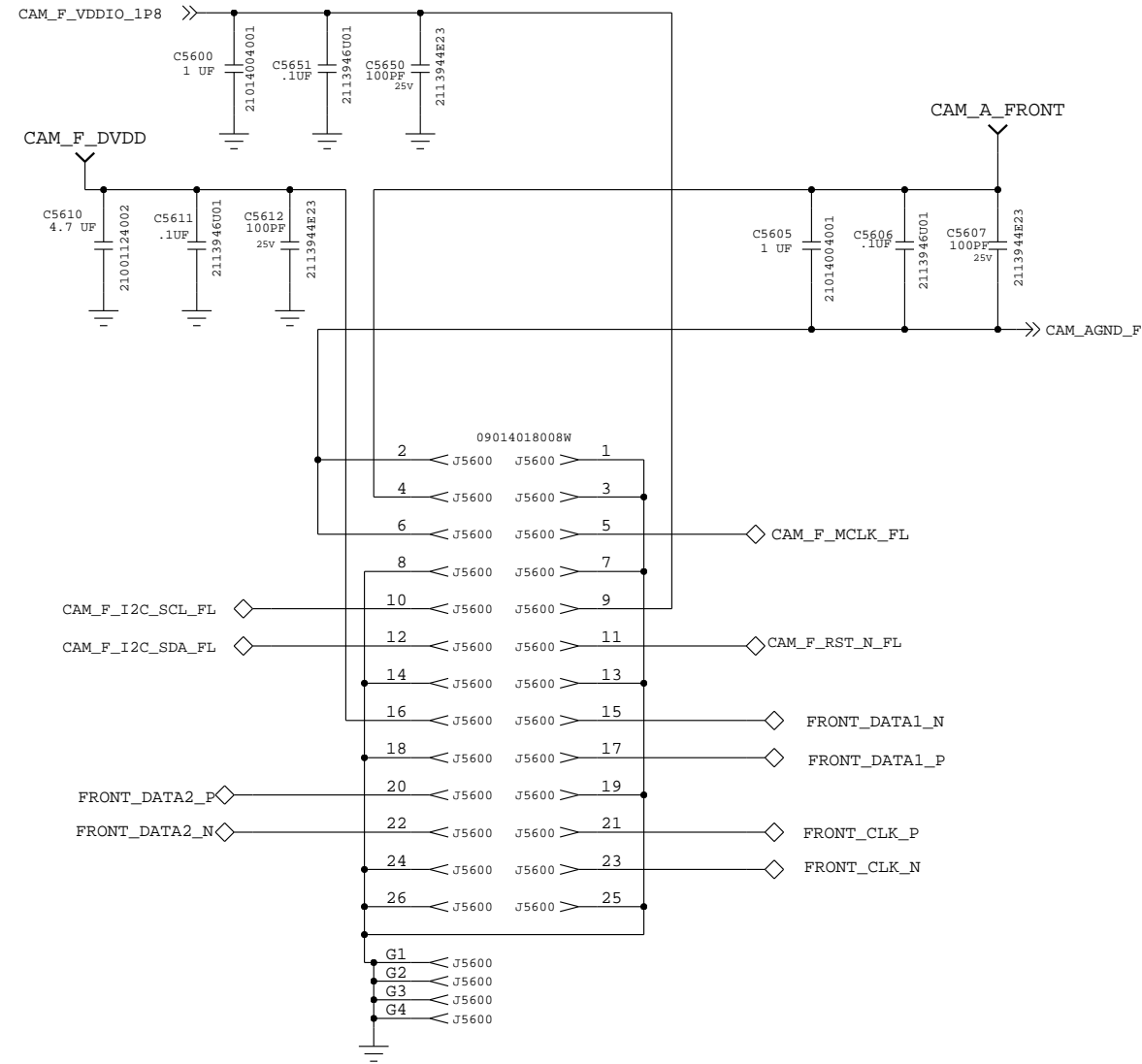

CAMERA ANALOG FRONT - 2.85V

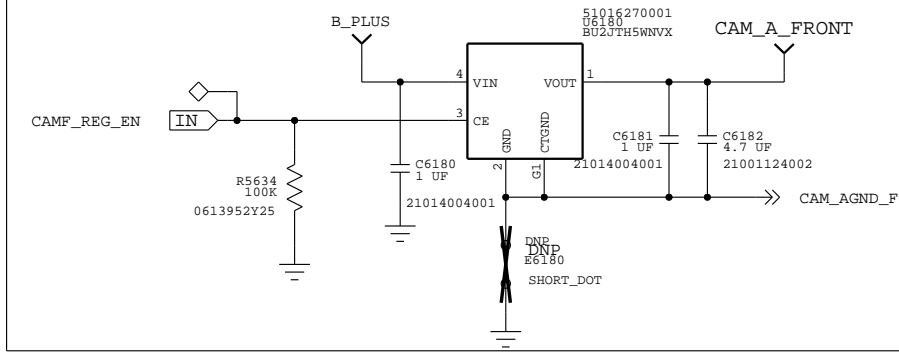

CAMERA FRONT DVDD - 1.2V

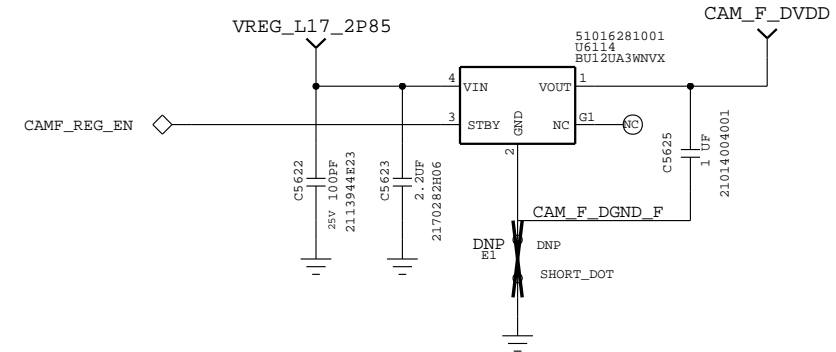

EMI/ESD FILTER

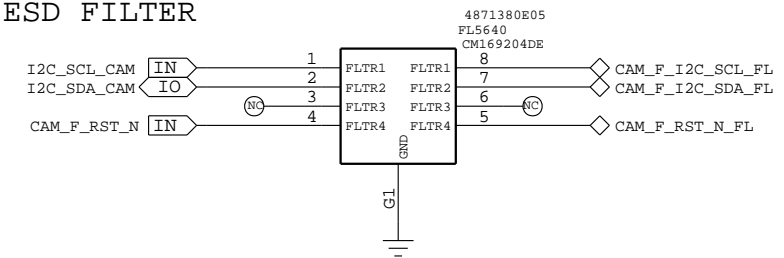

PLACE E5620 AND C5620 NEAR MSM

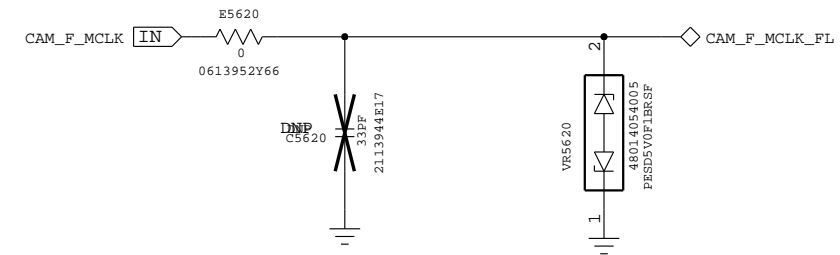

APPROVALS

ENGINEER: JOHN KRAMER

LAST MODIFIED BY: NATE CONNELL
Mon May 11 16:30:49 2015

MOTOROLA CONFIDENTIAL RESTRICTED

THE DRAWING ON THIS PRINT AND INFORMATION
THEREWITH ARE PROPRIETARY TO MOTOROLA AND
SHALL NOT BE USED OR DISCUSSED IN WHOLE
OR IN PART WITHOUT MOTOROLA'S CONSENT.
© COPYRIGHT, MOTOROLA. THIS DOES
NOT IMPLY PUBLICATION



BLOCK TITLE:

user_interface

PROJECT NAME
84016407.cpm

REV
01

CAD FILE NAME:

DISPLAY POWER

REF: 5300-5399

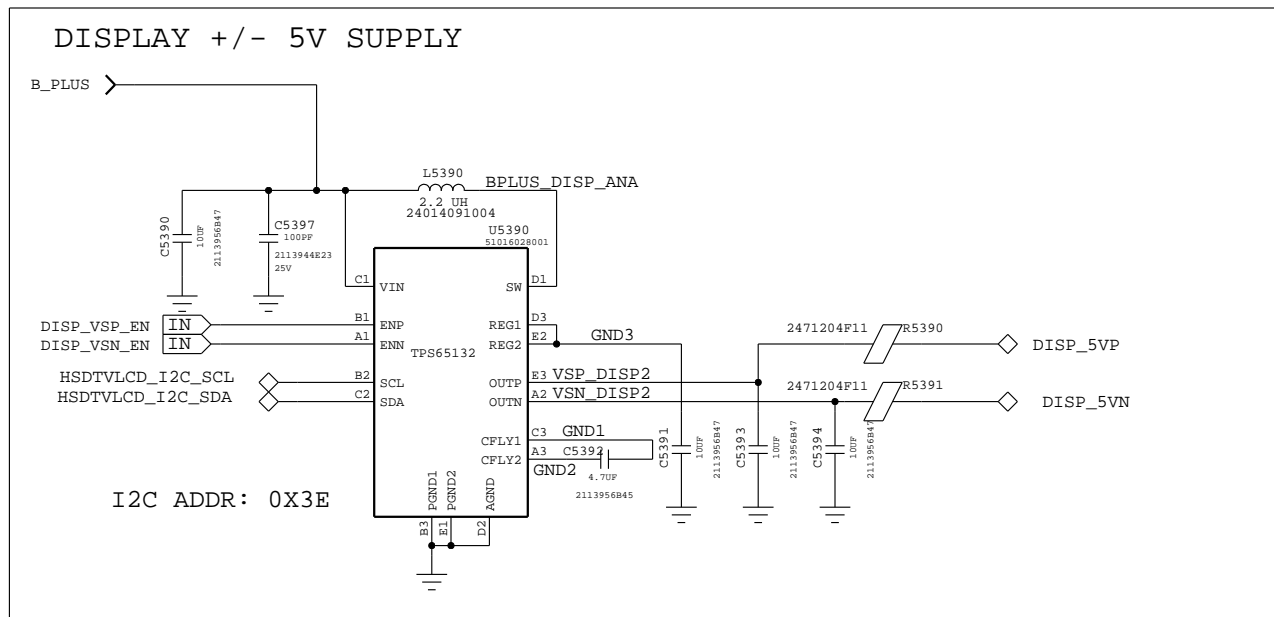
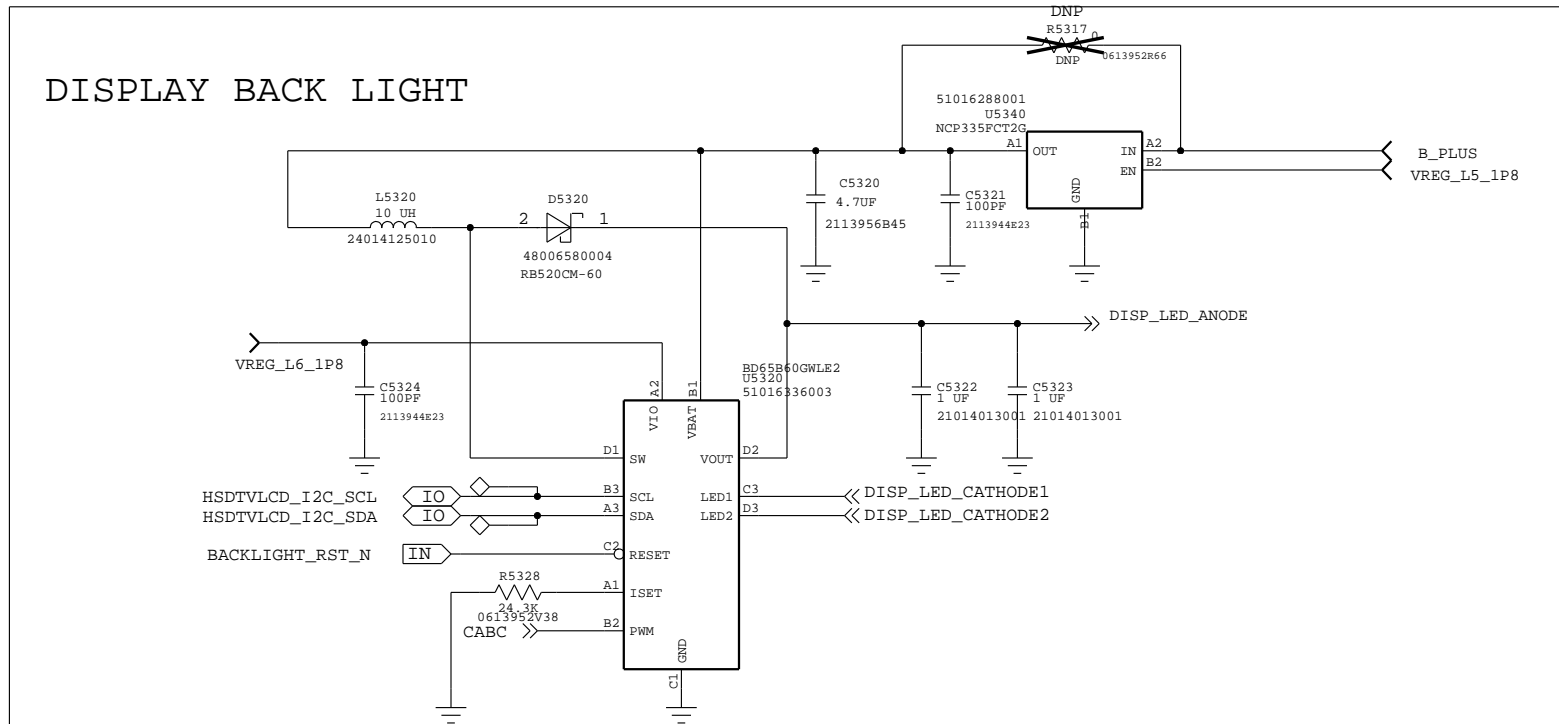
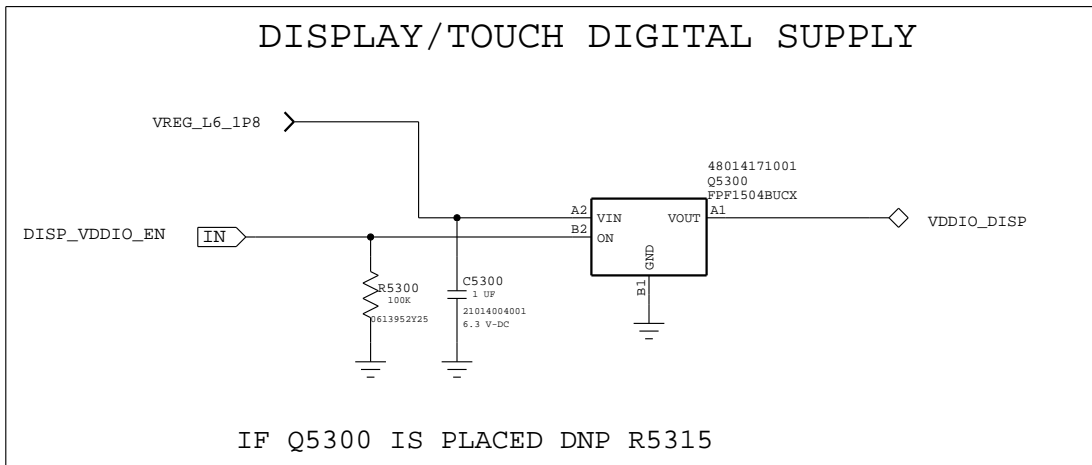
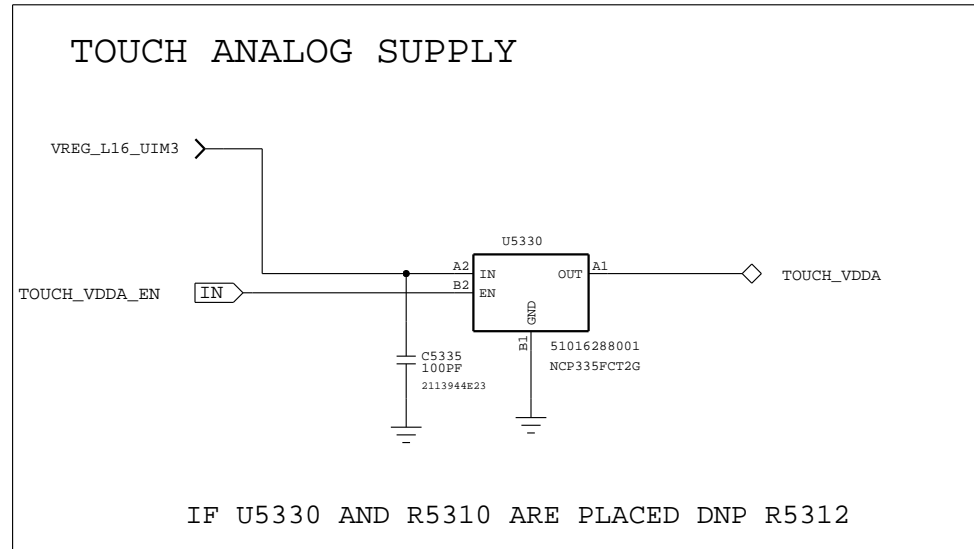

APPROVALS		MOTOROLA MOBILE DEVICES	
ENGINEER: MIGUEL DELEON		BLOCK TITLE:	
LAST MODIFIED BY: CARI HERNANDEZ Mon May 11 16:30:48 2015		user_interface	
MOTOROLA CONFIDENTIAL RESTRICTED THE DRAWING ON THIS PRINT AND INFORMATION THEREWITH ARE PROPRIETARY TO MOTOROLA AND SHALL NOT BE USED OR DISCUSSED IN WHOLE OR IN PART WITHOUT MOTOROLA'S CONSENT. © COPYRIGHT, MOTOROLA. THIS DOES NOT IMPLY PUBLICATION		PROJECT NAME B 84016407.cpm	REV 01
		CAD FILE NAME:	
		PAGE 30 OF 47	

DISPLAY CONNECTOR

REF: 5300-5399

REVISIONS				
REV	ECN	DESCRIPTION	MADE BY	APPROVED

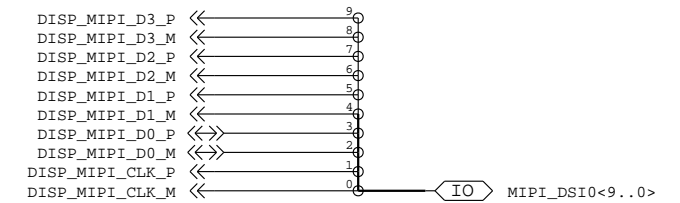
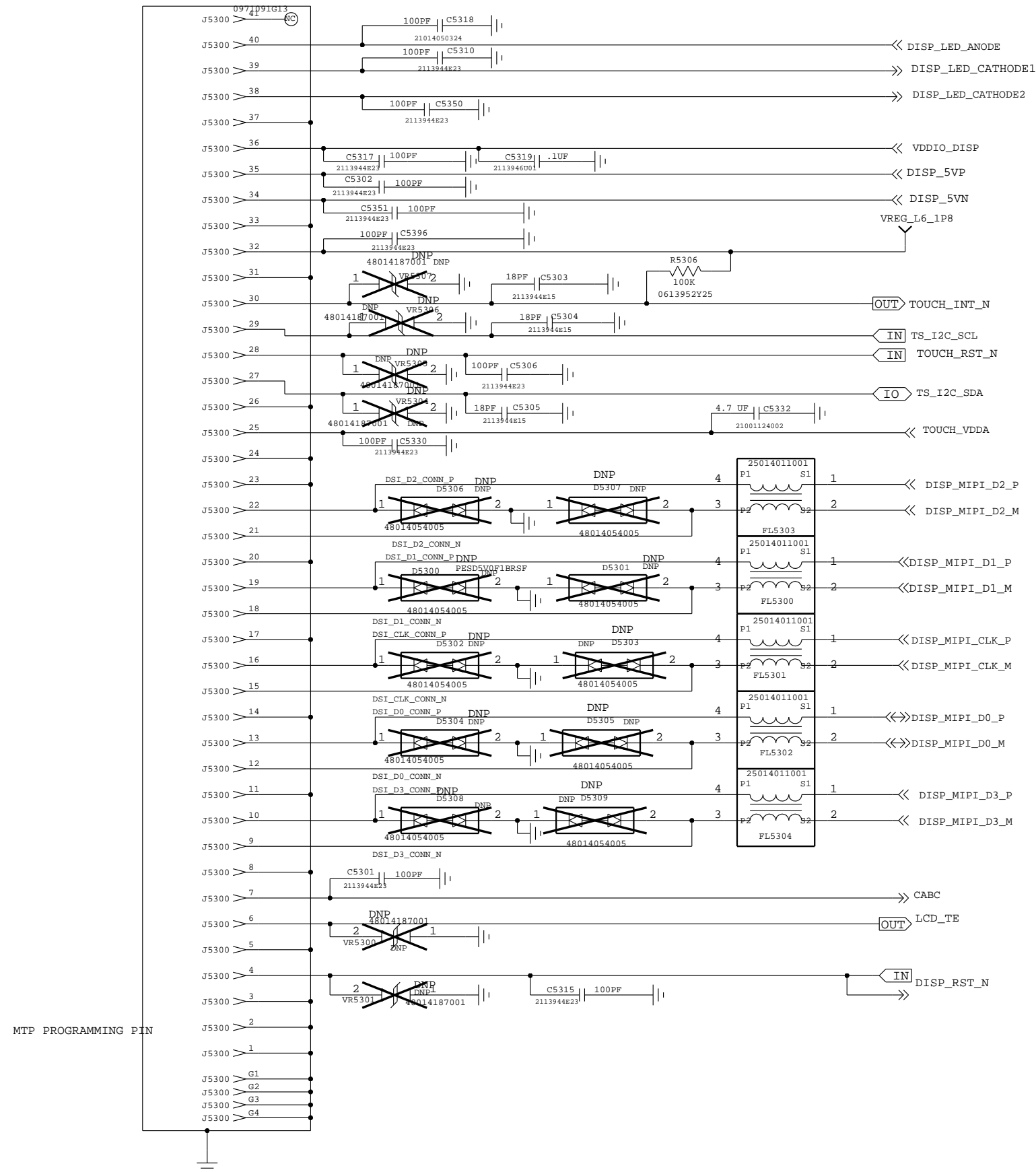

LAST MODIFIED: Mon May 11 16:30:51 2015

DRAWING NUMBER: 84		MOTOROLA	
DRAWN BY: MIGUEL DELEON	DATE:	TITLE:	REV 01
LEAD ENGINEER: MIGUEL DELEON	DATE:		SIZE B
ASSY NUMBER:	PCB FILE NAME:	PAGE 31 OF 47	

KEYS AND LEDS

REF

SOL + NOTIFICATION LED

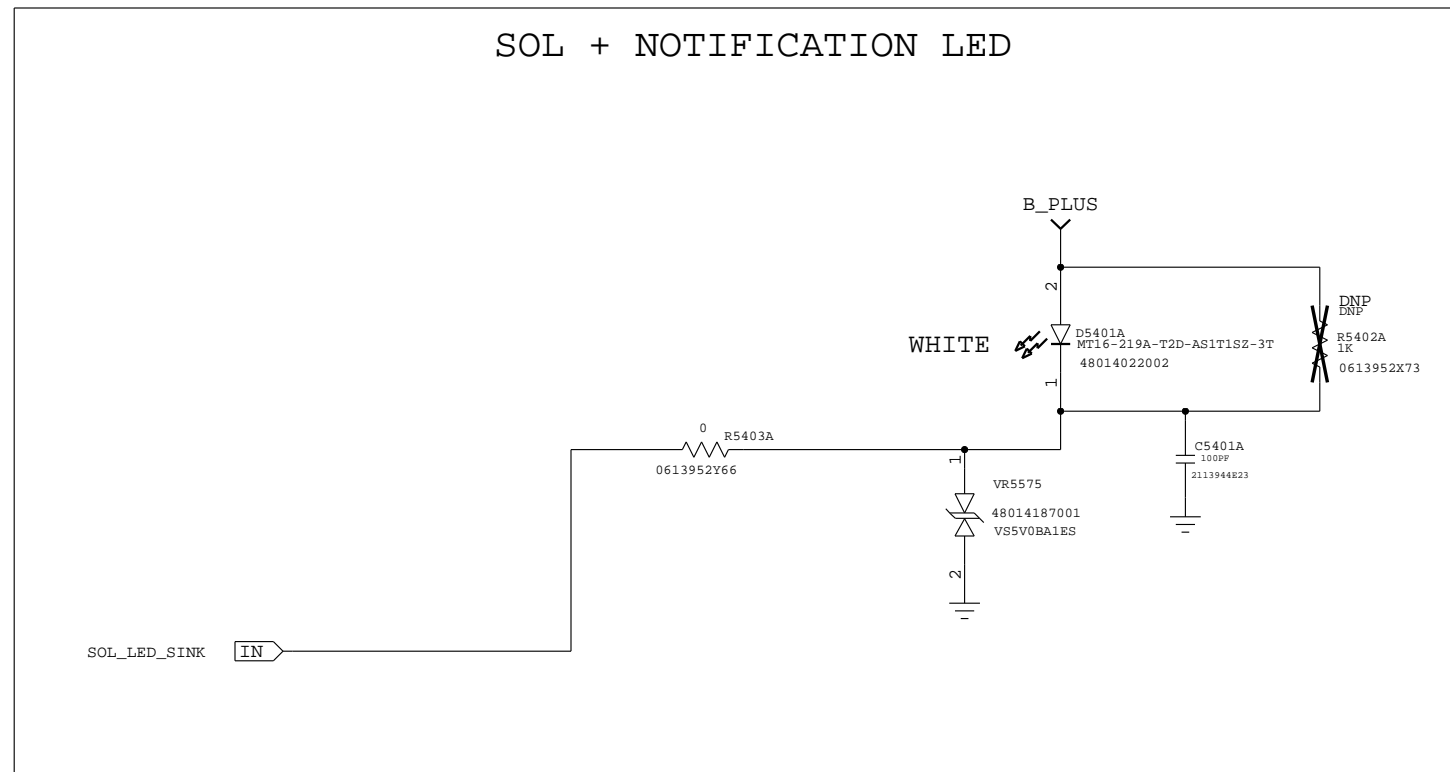

MECHANICAL KEYS

REF: 5570-5579

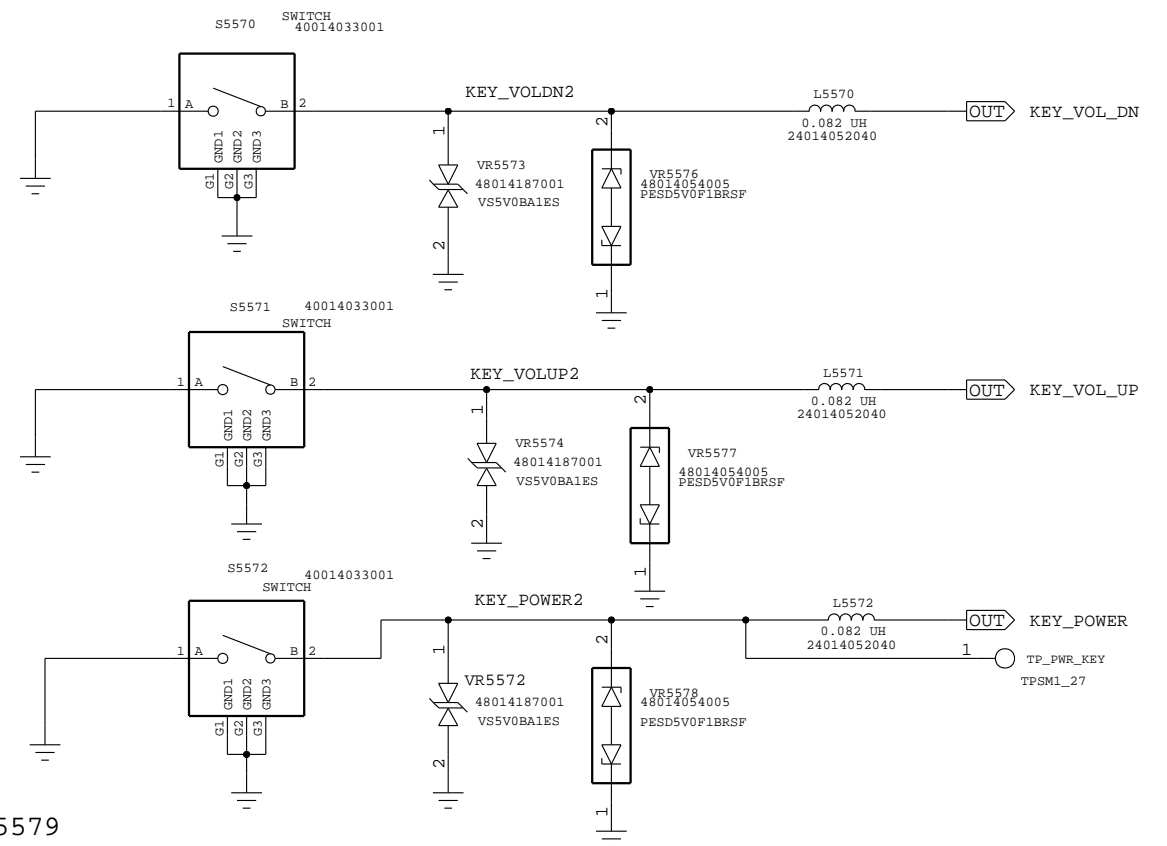

APPROVALS

ENGINEER: CARI HERNANDEZ

LAST MODIFIED BY: CARI HERNANDEZ
Mon May 11 16:30:45 2015

MOTOROLA CONFIDENTIAL RESTRICTED

THE DRAWING ON THIS PRINT AND INFORMATION
THEREWITH ARE PROPRIETARY TO MOTOROLA AND
SHALL NOT BE USED OR DISCUSSED IN WHOLE
OR IN PART WITHOUT MOTOROLA'S CONSENT.
© COPYRIGHT, MOTOROLA. THIS DOES
NOT IMPLY PUBLICATION



BLOCK TITLE:

user_interface

PROJECT NAME
B 84016407.cpm

REV
01

CAD FILE NAME:

PAGE 32 OF 47

USB_BATTERY

REF:5000 - 5299

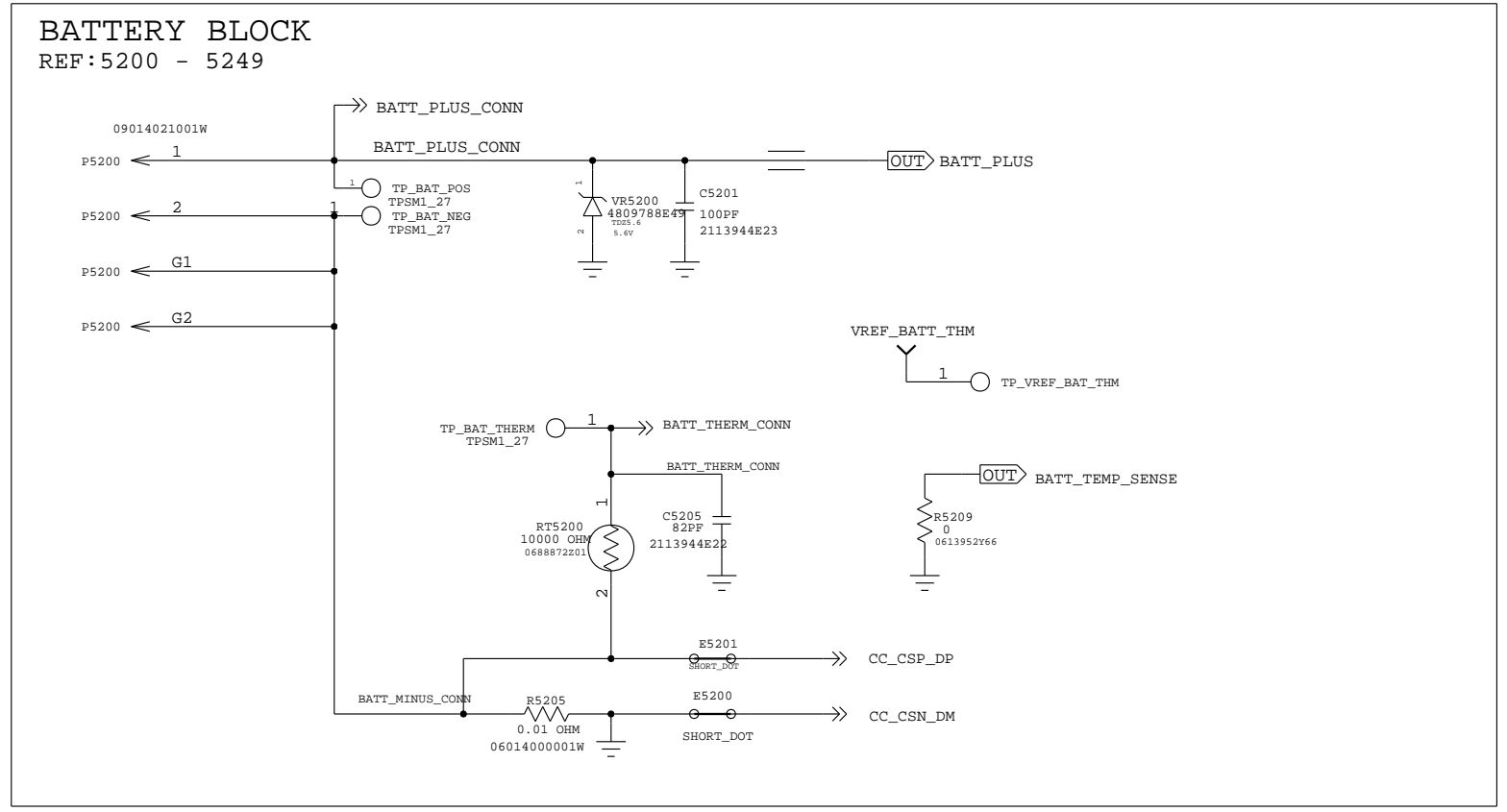
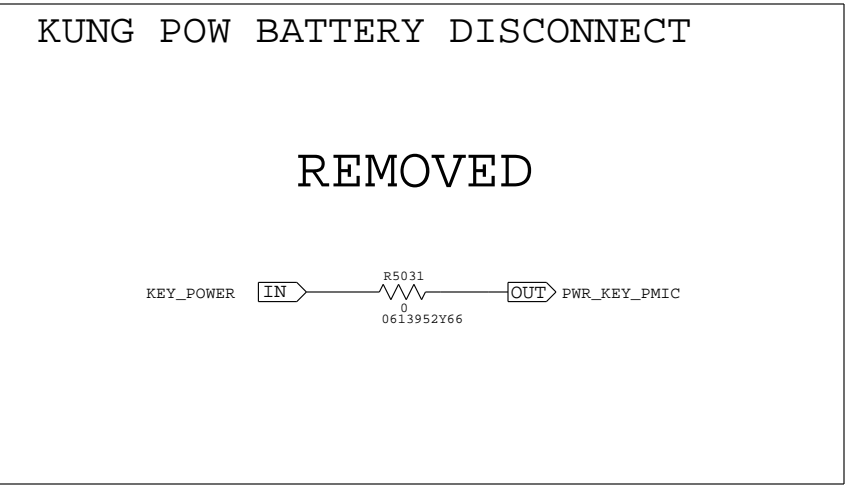
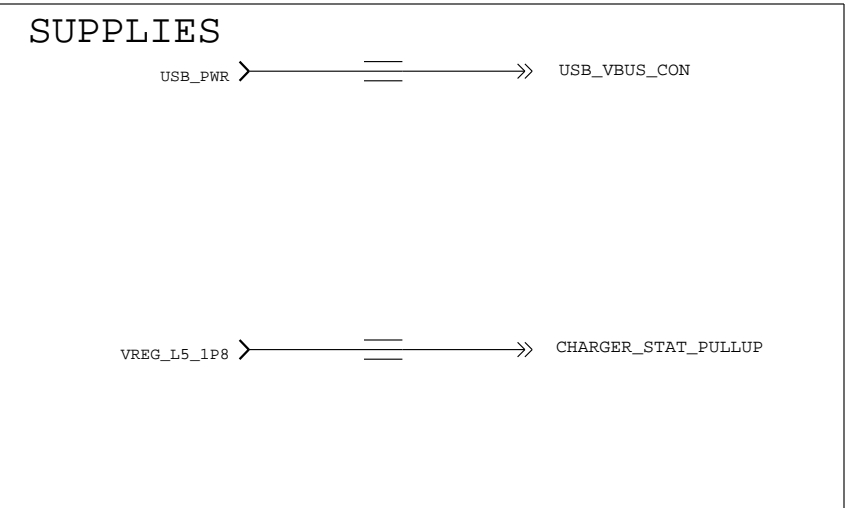
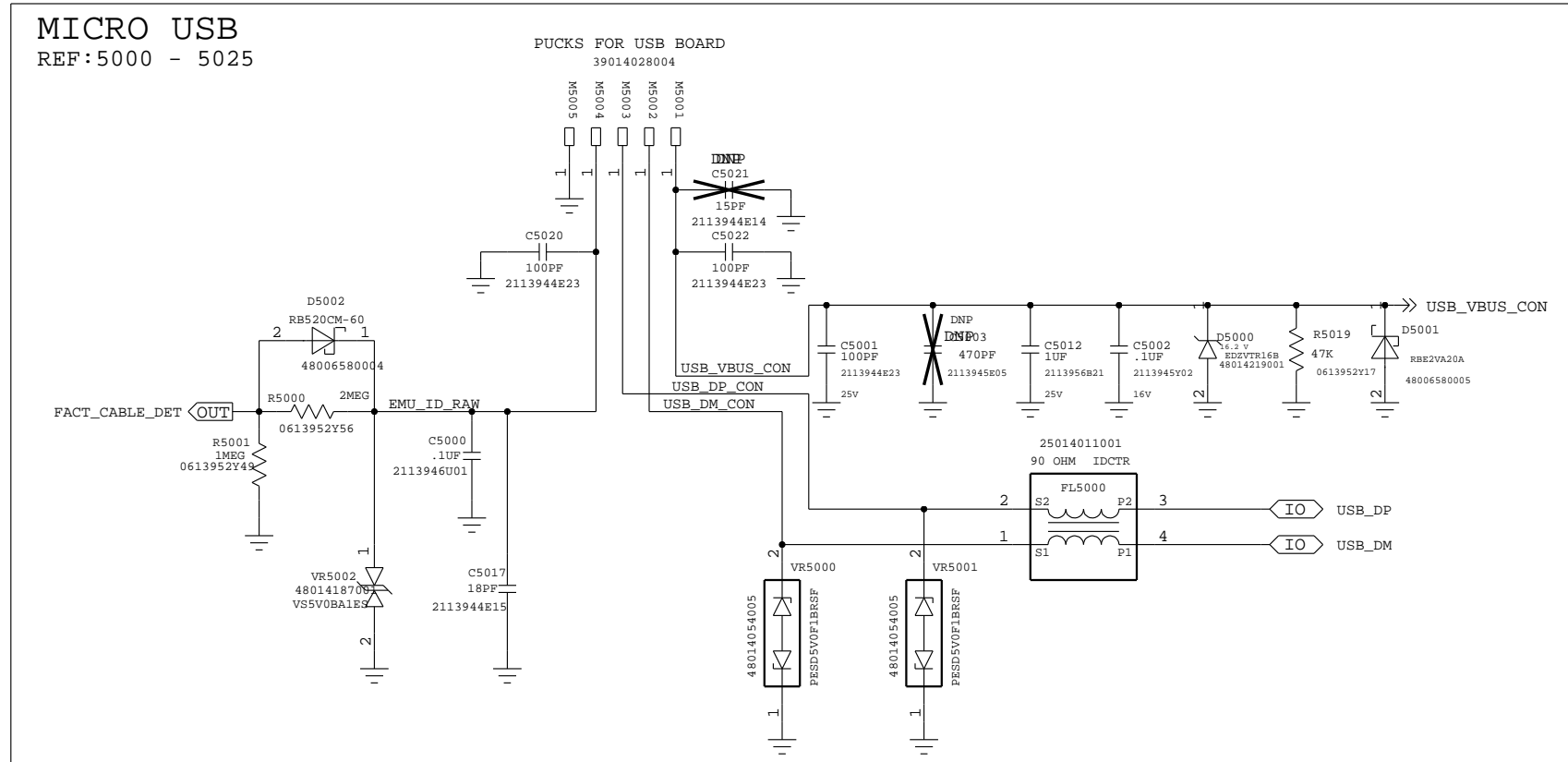

APPROVALS		MOTOROLA MOBILE DEVICES	
ENGINEER: XIAOYU WANG		BLOCK TITLE:	
LAST MODIFIED BY: NATE CONNELL Mon May 11 16:30:50 2015		user_interface	
MOTOROLA CONFIDENTIAL RESTRICTED THE DRAWING ON THIS PRINT AND INFORMATION THEREWITH ARE PROPRIETARY TO MOTOROLA AND SHALL NOT BE USED OR DISCUSSED IN WHOLE OR IN PART WITHOUT MOTOROLA'S CONSENT. © COPYRIGHT, MOTOROLA. THIS DOES NOT IMPLY PUBLICATION		PROJECT NAME B 84016407.cpm	REV 01
CAD FILE NAME:		PAGE 33 OF 47	

CHARGING

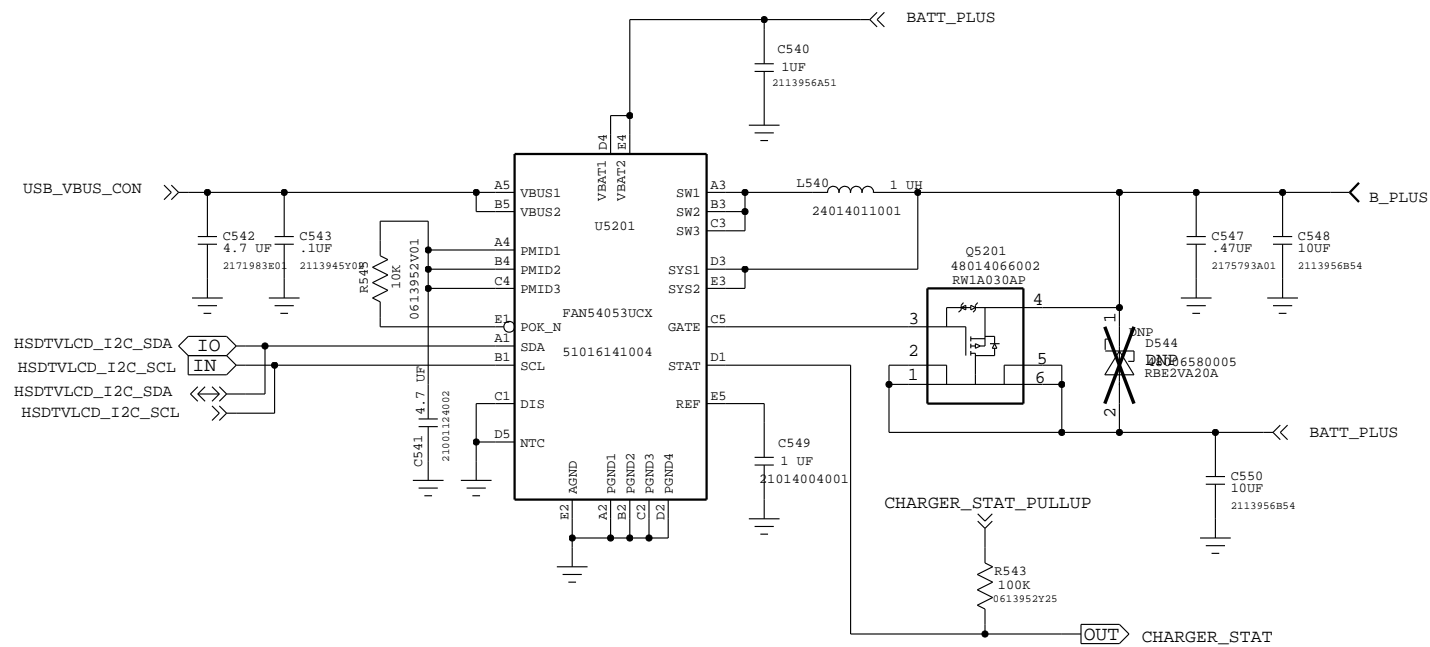

FUEL GAUGE

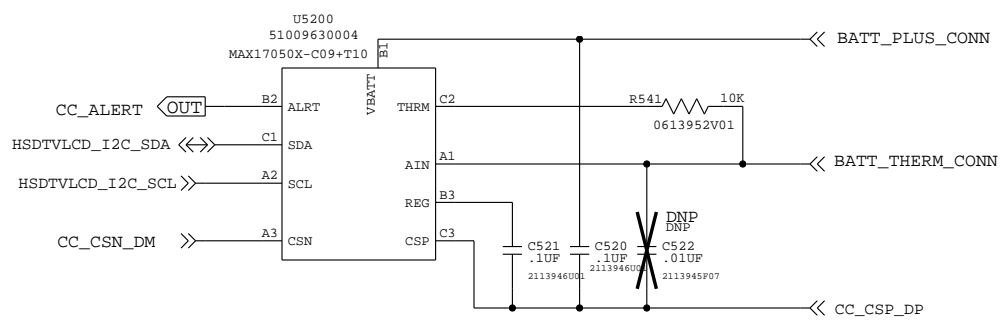

APPROVALS

ENGINEER: MMI
 LAST MODIFIED BY: MMI
 Mon May 11 16:30:45 2015

MOTOROLA CONFIDENTIAL RESTRICTED

THE DRAWING ON THIS PRINT AND INFORMATION
 THEREWITH ARE PROPRIETARY TO MOTOROLA AND
 SHALL NOT BE USED OR DISCUSSED IN WHOLE
 OR IN PART WITHOUT MOTOROLA'S CONSENT.
 © COPYRIGHT, MOTOROLA. THIS DOES
 NOT IMPLY PUBLICATION



BLOCK TITLE:
user_interface

B	PROJECT NAME	REV
	84016407.cpm	01

CAD FILE NAME: _____ PAGE 34 OF 47

DAUGHTER BOARD CONNECTOR

REF 4500-4599

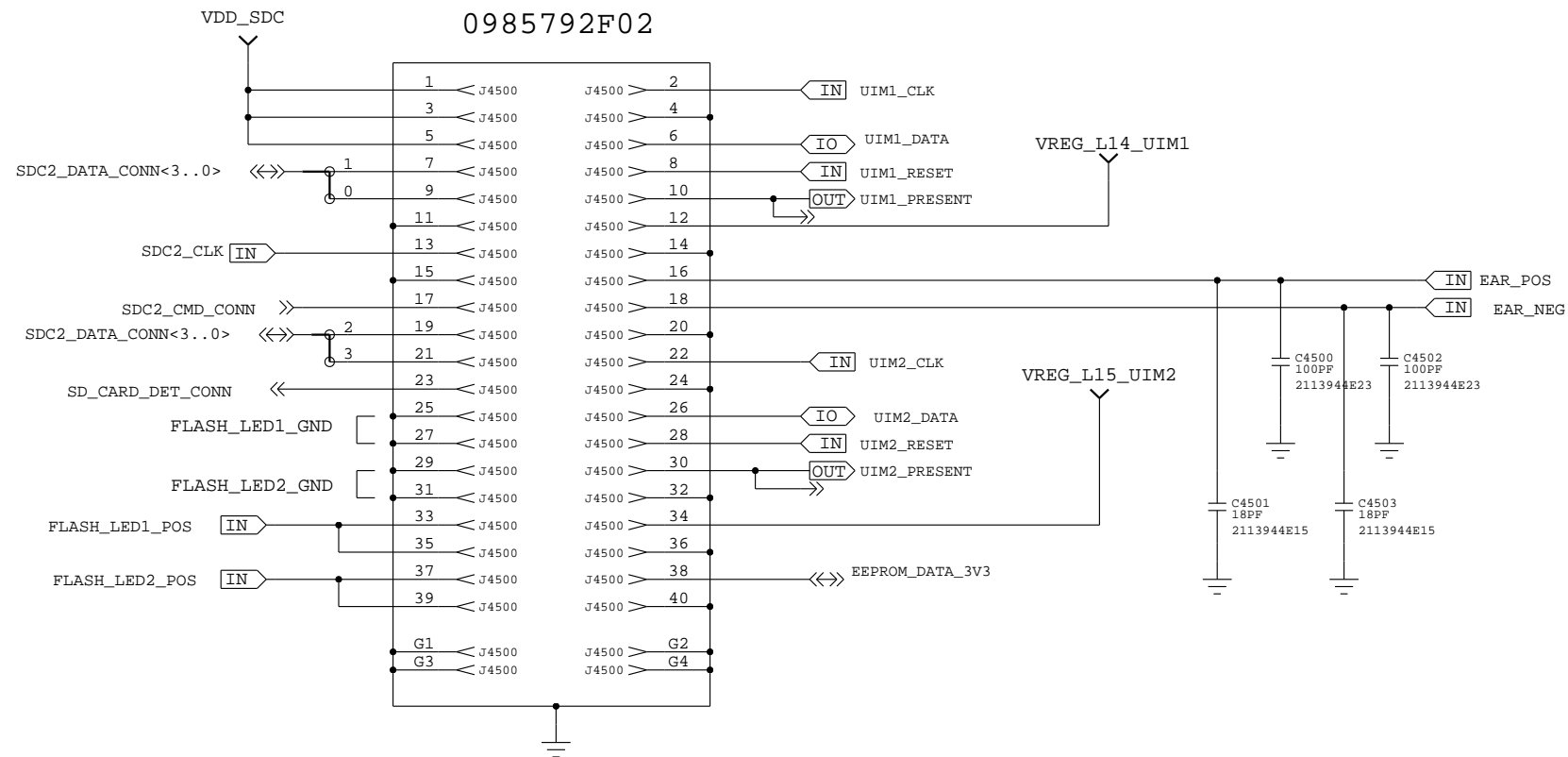

MOTOROLA MOBILITY CONFIDENTIAL RESTRICTED-MDR TRACKED TRACKEDANDBLOCKED

APPROVALS		MOTOROLA MOBILE DEVICES	
ENGINEER: CARI HERNANDEZ		BLOCK TITLE:	
LAST MODIFIED BY: CARI HERNANDEZ Mon May 11 16:30:54 2015		daughter_board_conn	
MOTOROLA CONFIDENTIAL RESTRICTED		PROJECT NAME	REV
THE DRAWING ON THIS PRINT AND INFORMATION THEREWITH ARE PROPRIETARY TO MOTOROLA AND SHALL NOT BE USED OR DISCUSSED IN WHOLE OR IN PART WITHOUT MOTOROLA'S CONSENT. © COPYRIGHT, MOTOROLA. THIS DOES NOT IMPLY PUBLICATION		B 84016407.cpm	01
		CAD FILE NAME:	
		PAGE 35 OF 47	

SIM/SD/FLASH CARD SUPPORT

SD CARD POWER SUPPLY

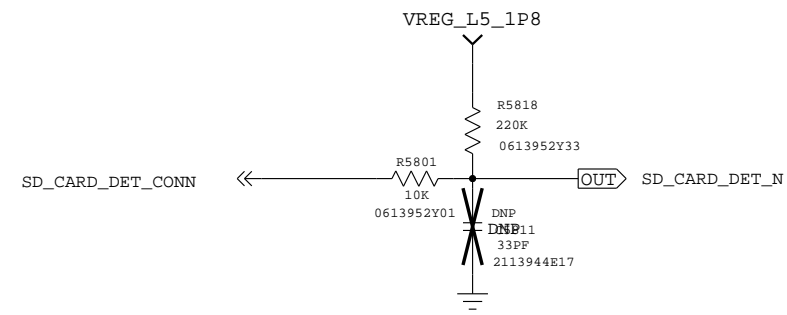
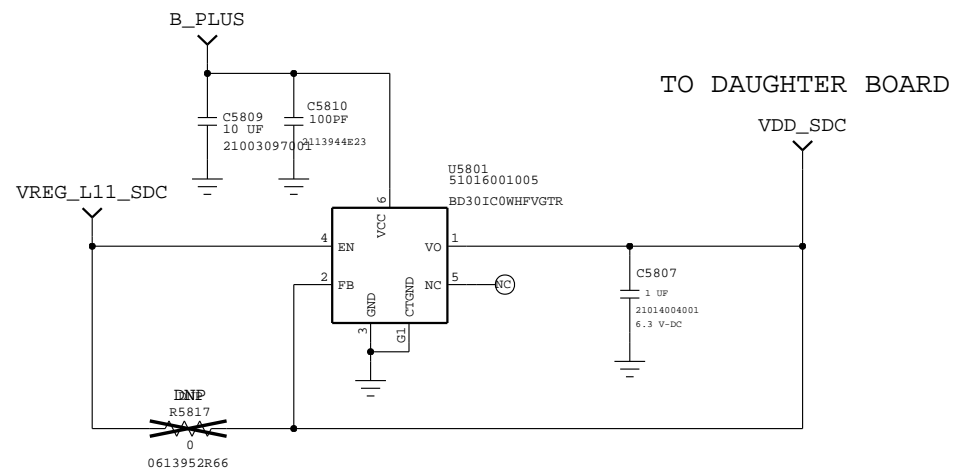

PULLUPS FOR SIM DETECT

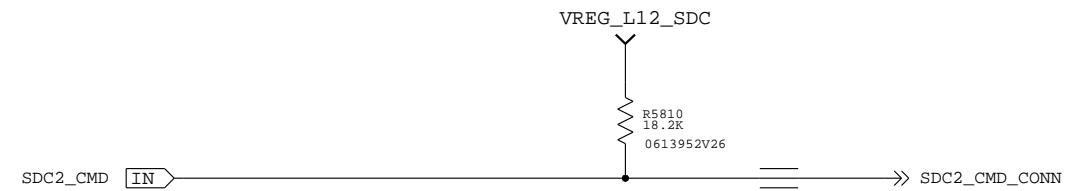
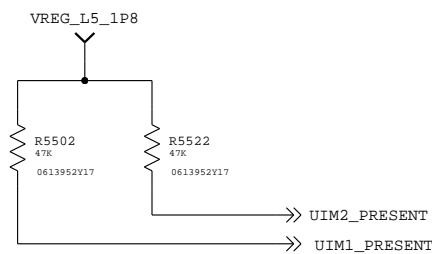

LEVEL SHIFT FOR FLASH LED EEPROM DATA

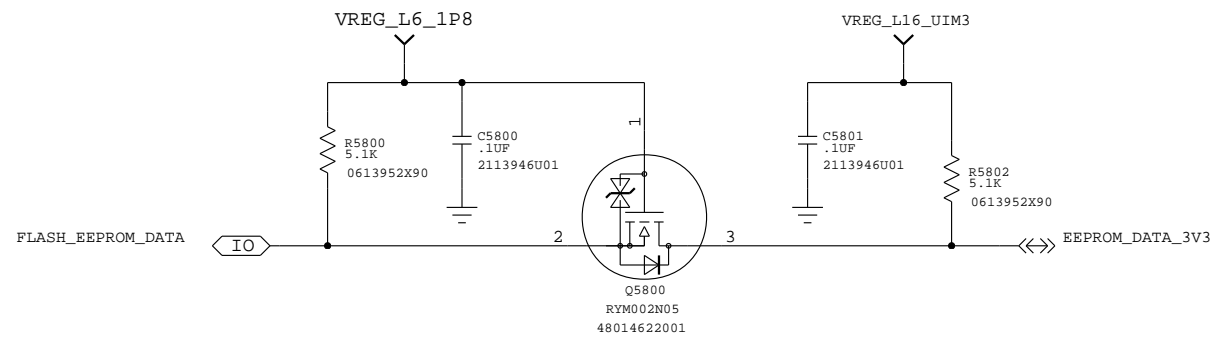

MOTOROLA MOBILITY CONFIDENTIAL RESTRICTED-MDR_TRACKED_TRACKEDANDBLOCKED

APPROVALS		 MOTOROLA MOBILE DEVICES	
ENGINEER: CARLOS TORRES		BLOCK TITLE:	
LAST MODIFIED BY: CARLOS TORRES Mon May 11 16:30:55 2015		daughter_board_conn	
MOTOROLA CONFIDENTIAL RESTRICTED <small>THE DRAWING ON THIS PRINT AND INFORMATION THEREWITH ARE PROPRIETARY TO MOTOROLA AND SHALL NOT BE USED OR DISCUSSED IN WHOLE OR IN PART WITHOUT MOTOROLA'S CONSENT. © COPYRIGHT, MOTOROLA. THIS DOES NOT IMPLY PUBLICATION</small>		PROJECT NAME	REV
		B 84016407.cpm	01
CAD FILE NAME:		PAGE 36 OF 47	

MICS

REF: 5700-5799

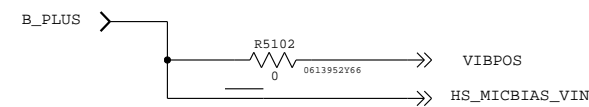
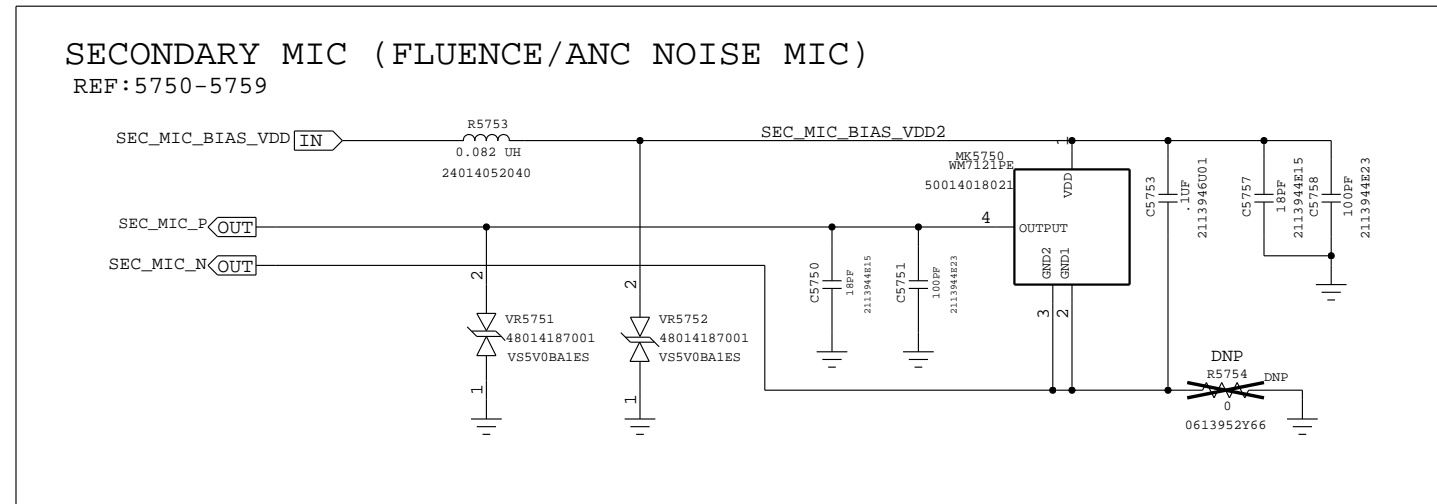
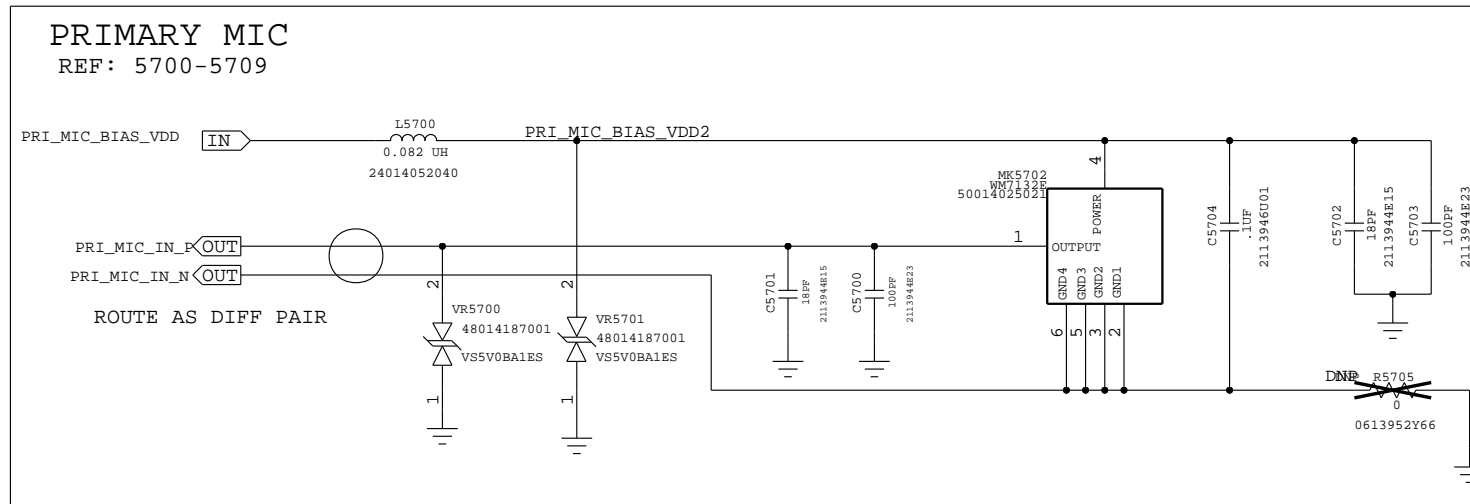

APPROVALS		MOTOROLA MOBILE DEVICES	
ENGINEER: DENNIS BUDNICK		BLOCK TITLE:	
LAST MODIFIED BY: NATE CONNELL Mon May 11 16:30:57 2015		audio_fe	
MOTOROLA CONFIDENTIAL RESTRICTED <small>THE DRAWING ON THIS PRINT AND INFORMATION THEREWITH ARE PROPRIETARY TO MOTOROLA AND SHALL NOT BE USED OR DISCUSSED IN WHOLE OR IN PART WITHOUT MOTOROLA'S CONSENT. © COPYRIGHT, MOTOROLA. THIS DOES NOT IMPLY PUBLICATION</small>		PROJECT NAME B 84016407.cpm	REV 01
		CAD FILE NAME:	
		PAGE 37 OF 47	

SPEAKER_VIB

LOUDSPEAKER

REF: 5780-5789

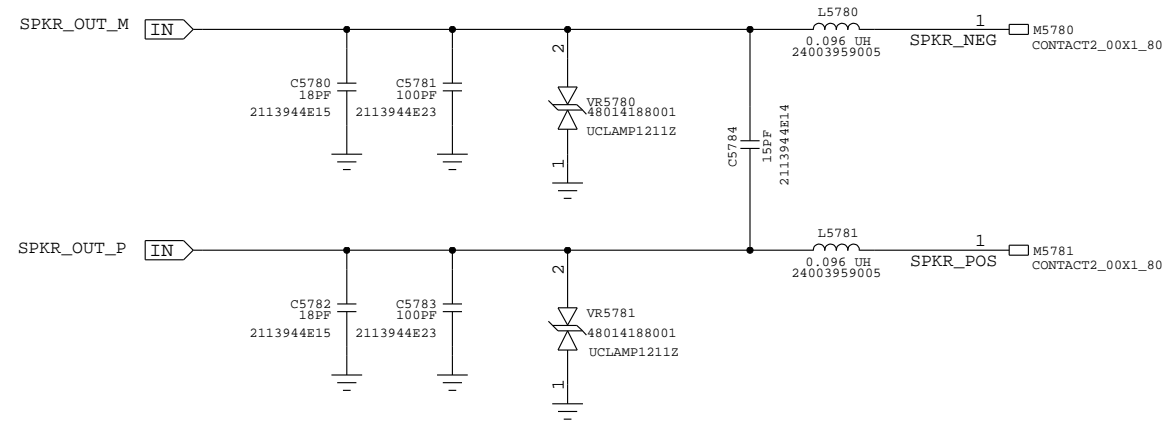

EARPIECE TRANSDUCER

REF: 5780-5789

EARPIECE MOVED TO DAUGHTER CARD

ROTARY VIBRATOR

REF 5100-5119

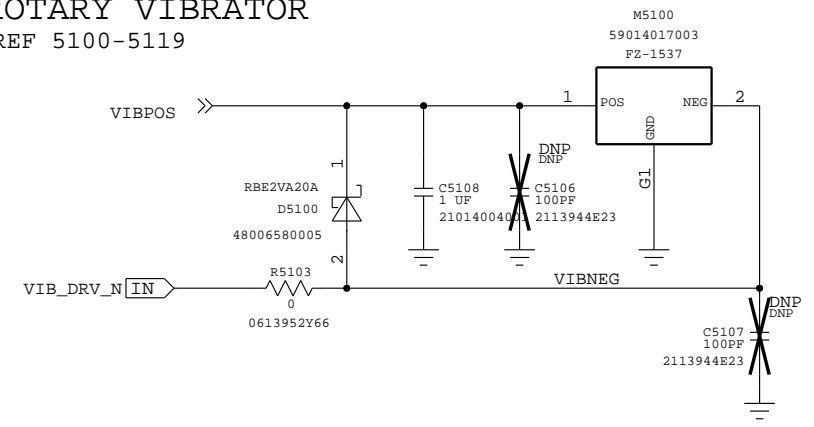

APPROVALS

ENGINEER: DENNIS BUDNICK

LAST MODIFIED BY: TIM MILLER
Mon May 11 16:30:57 2015

MOTOROLA CONFIDENTIAL RESTRICTED

THE DRAWING ON THIS PRINT AND INFORMATION
THEREWITH ARE PROPRIETARY TO MOTOROLA AND
SHALL NOT BE USED OR DISCUSSED IN WHOLE
OR IN PART WITHOUT MOTOROLA'S CONSENT.
© COPYRIGHT, MOTOROLA. THIS DOES
NOT IMPLY PUBLICATION



BLOCK TITLE:

audio_fe

PROJECT NAME
B 84016407.cpm

REV
01

CAD FILE NAME:

PAGE 38 OF 47

3.5MM HEADSET

SENSOR HUB HEADSET DETECTION CIRCUIT

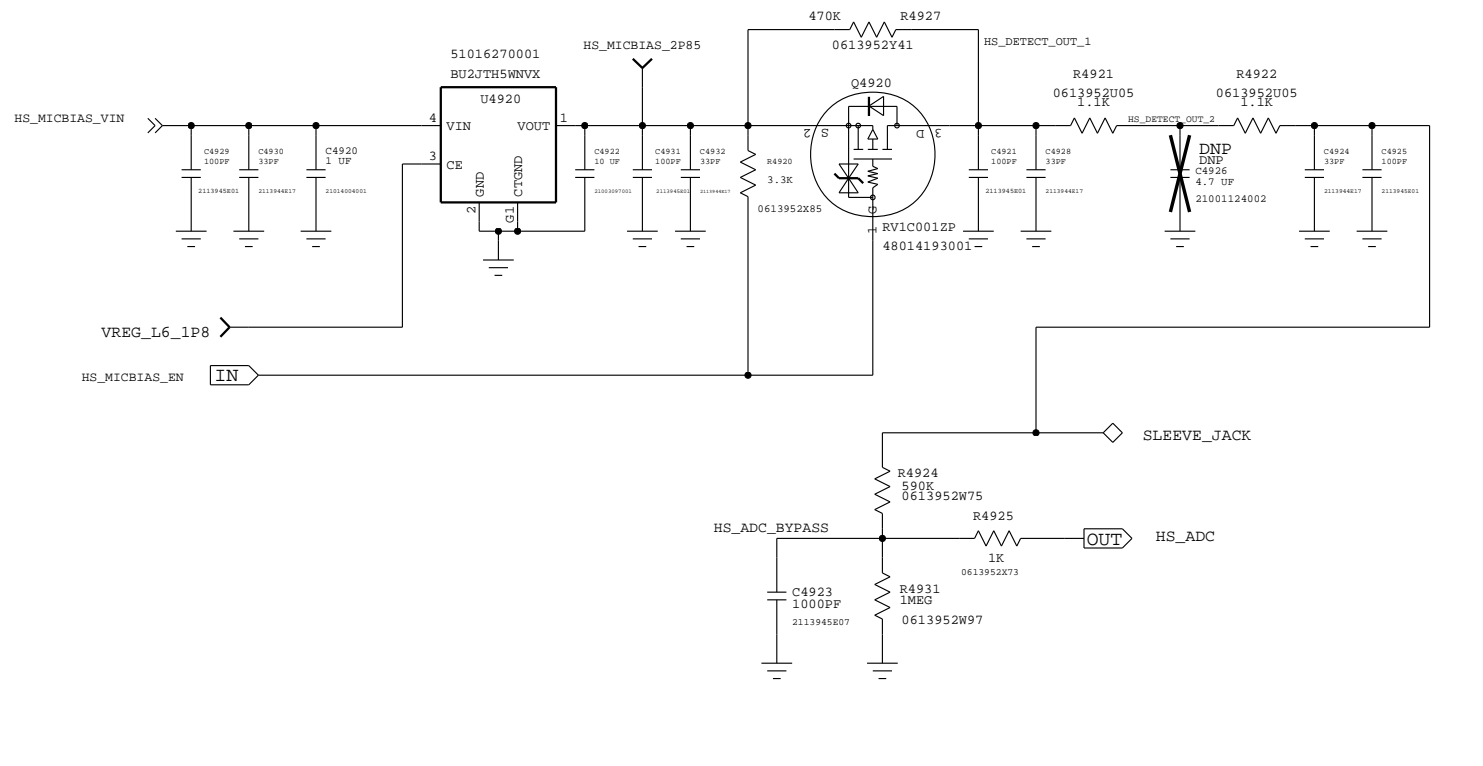

REF:4900-4949

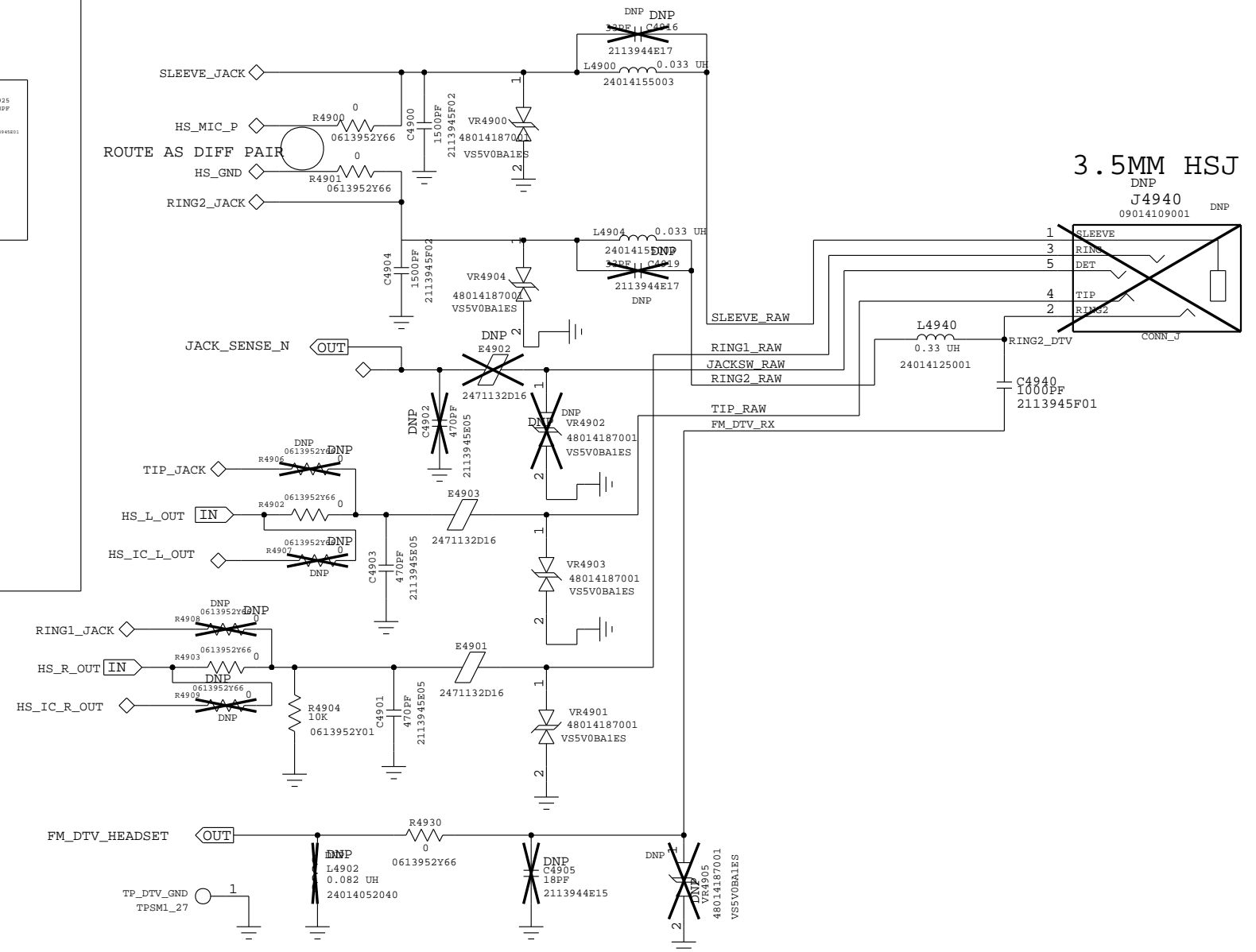

3.5MM HSJ

J4940

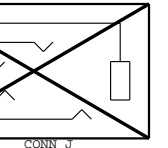

AUDIO JACK DETECTION

REF:4800-4849

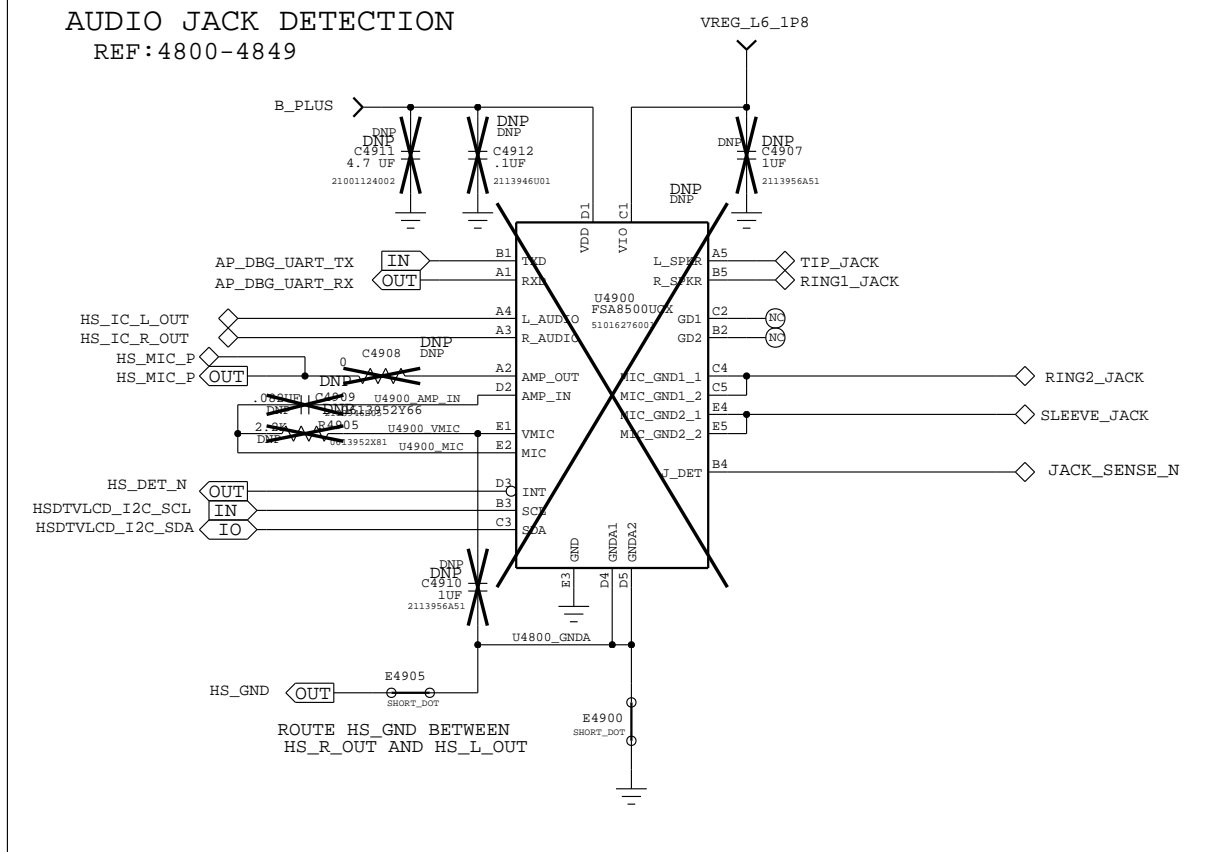

ROUTE HS_GND BETWEEN HS_R_OUT AND HS_L_OUT

APPROVALS

ENGINEER: MMI
 LAST MODIFIED BY: MMI
 Mon May 11 16:30:56 2015

MOTOROLA CONFIDENTIAL RESTRICTED

THE DRAWING ON THIS PRINT AND INFORMATION THEREWITH ARE PROPRIETARY TO MOTOROLA AND SHALL NOT BE USED OR DISCUSSED IN WHOLE OR IN PART WITHOUT MOTOROLA'S CONSENT.
 © COPYRIGHT, MOTOROLA. THIS DOES NOT IMPLY PUBLICATION



BLOCK TITLE:
audio_fe

PROJECT NAME: 84016407.cpm
 REV: 01

CAD FILE NAME:
 PAGE 39 OF 47

MSM8X36 RF INTERFACE

REF 1200-1299

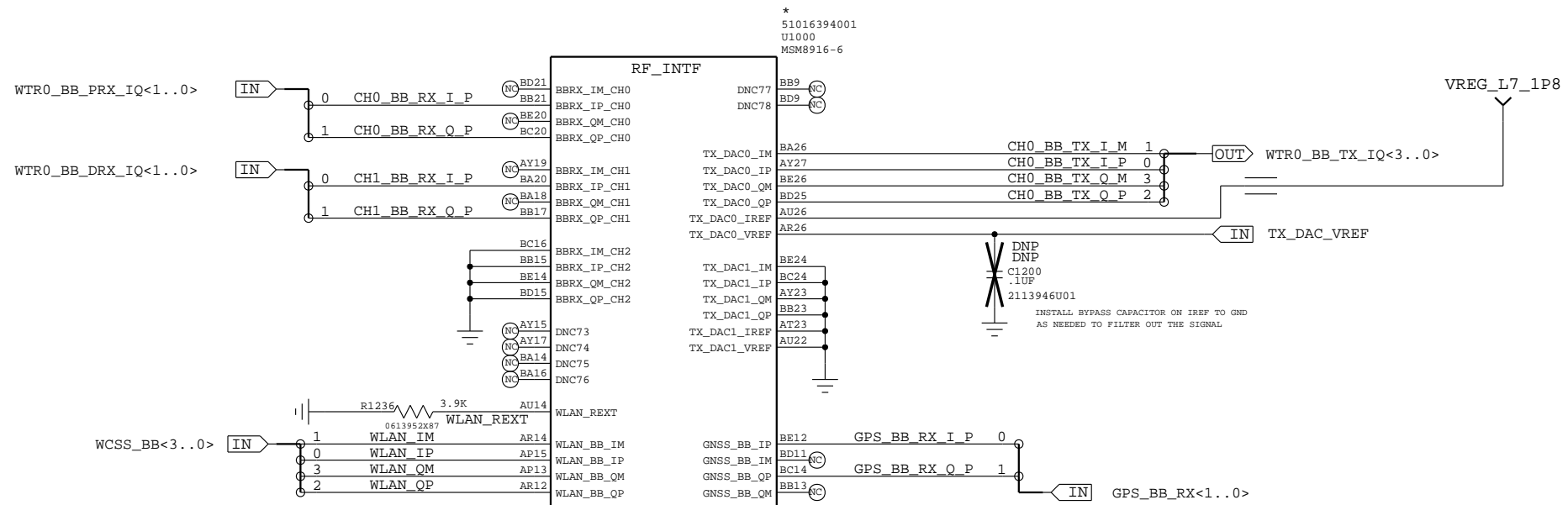

INFO: QC DOES NOT HAVE SOME BUSES SO SOME OF THE NAMES ARE COPIED FROM DVX

APPROVALS		MOTOROLA MOBILE DEVICES	
ENGINEER:		BLOCK TITLE:	
LAST MODIFIED BY: FAN021 Mon May 11 16:30:59 2015		block_msm8x16_rf	
MOTOROLA CONFIDENTIAL RESTRICTED <small>THE DRAWING ON THIS PRINT AND INFORMATION THEREWITH ARE PROPRIETARY TO MOTOROLA AND SHALL NOT BE USED OR DISCUSSED IN WHOLE OR IN PART WITHOUT MOTOROLA'S CONSENT. © COPYRIGHT, MOTOROLA. THIS DOES NOT IMPLY PUBLICATION</small>		PROJECT NAME	REV
		B 84016407.cpm	01
CAD FILE NAME:		PAGE 40 OF 47	

RFFE:SP10T+SP4T

REF 7000-7099

REVISIONS				
REV	ECN	DESCRIPTION	MADE BY	APPROVED

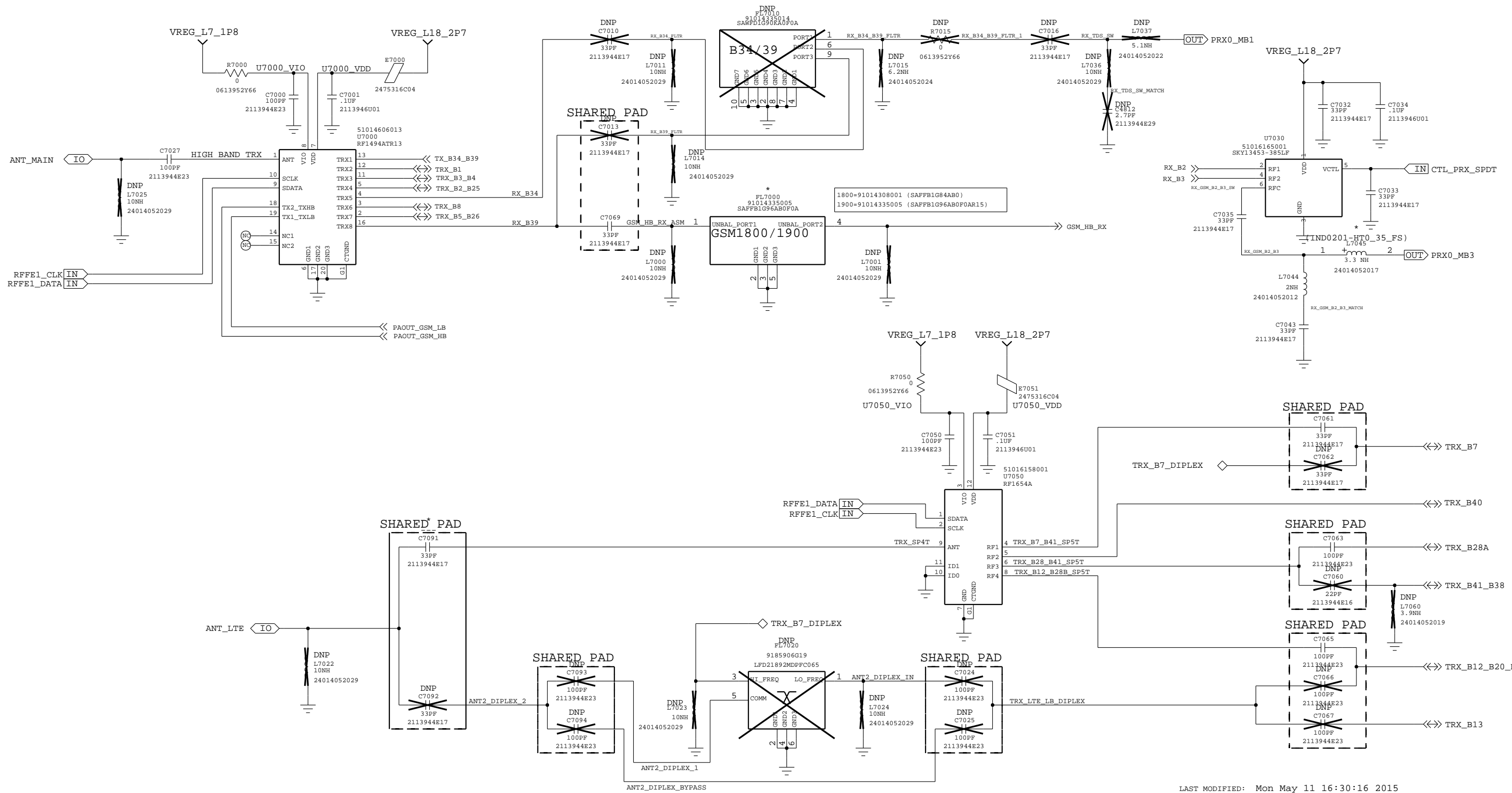

LAST MODIFIED: Mon May 11 16:30:16 2015

DRAWING NUMBER: 84			
DRAWN BY:	DATE:		
LEAD ENGINEER:	DATE:		SIZE B
ASSY NUMBER:	PCB FILE NAME:	PAGE 41 OF 47	

MOTOROLA CONFIDENTIAL RESTRICTED

RFFE : MMBBPA

REF 7100-7299

REVISIONS				
REV	ECN	DESCRIPTION	MADE BY	APPROVED

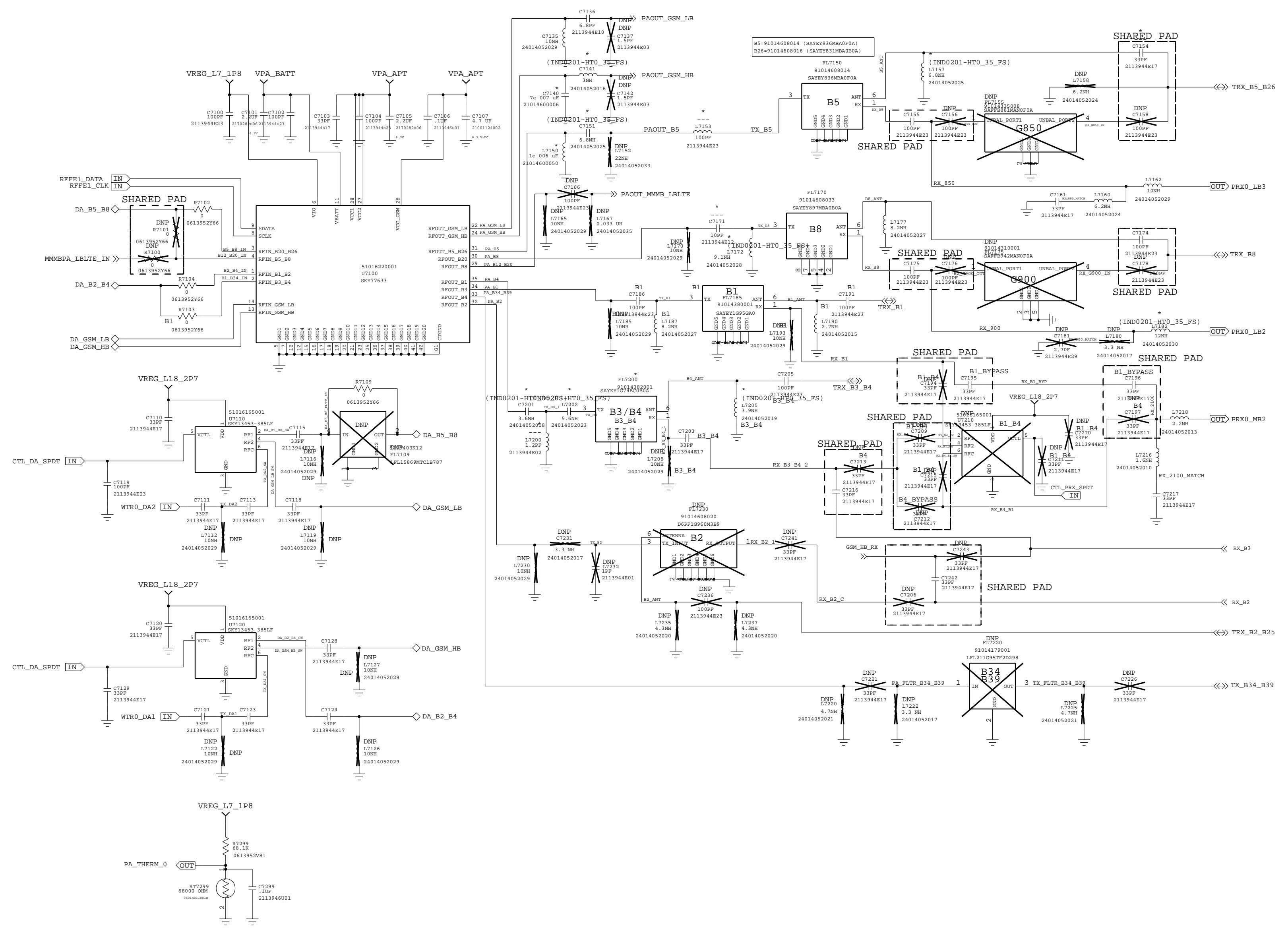

LAST MODIFIED: Mon May 11 16:30:14 2015

DRAWING NUMBER: 84			
DRAWN BY:	DATE:	TITLE:	REV 01
LEAD ENGINEER:	DATE:		SIZE C
ASSY NUMBER:	PCB FILE NAME:	PAGE 42 OF 47	

MOTOROLA CONFIDENTIAL RESTRICTED

RFFE:HBPA

REF 7300-7399

D

C

B

A

D

C

B

A

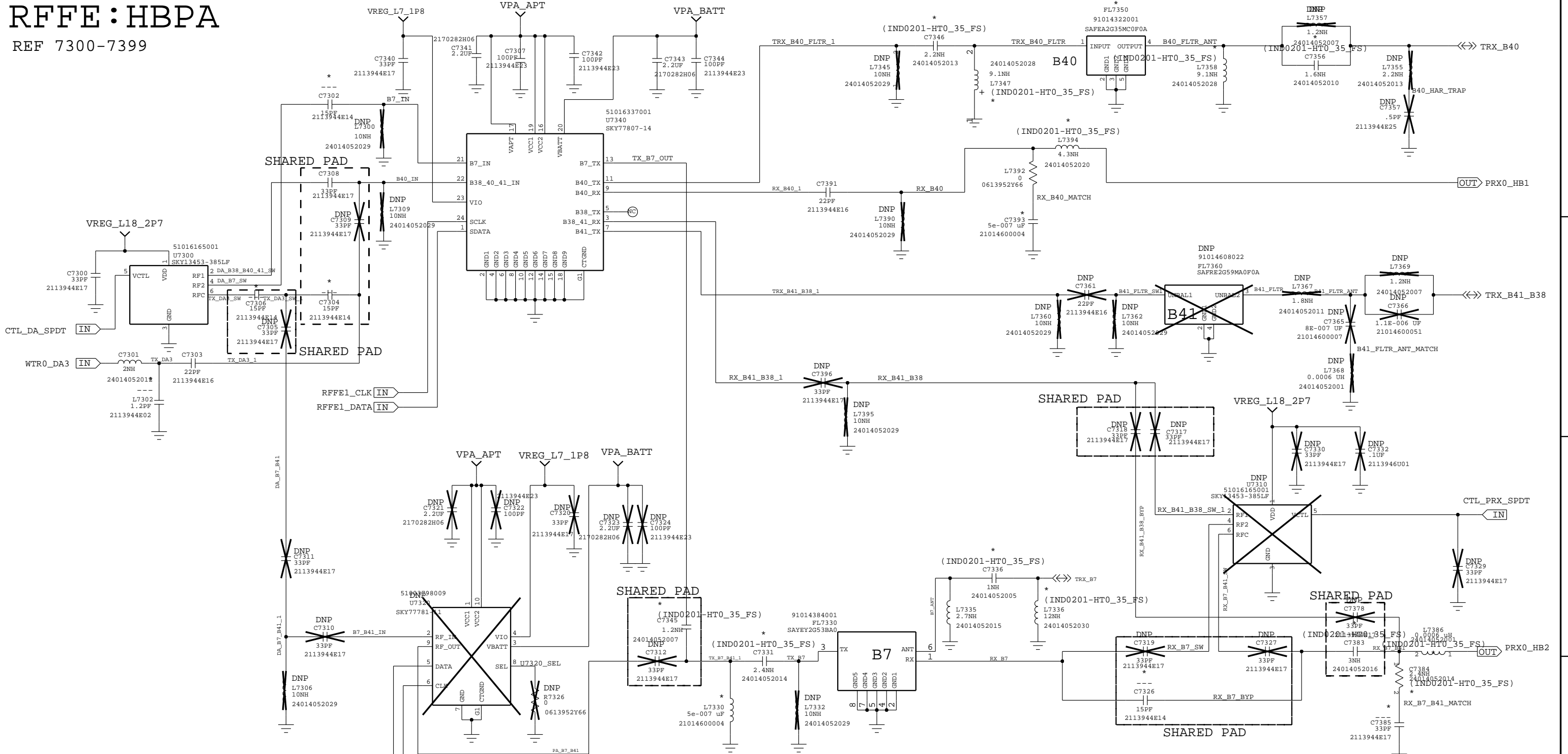

FOR MULTIPLE VENDOR CAPATIBILITY
B7=SKY77781-11, R7326=PLACED

APPROVALS		MOTOROLA MOBILE DEVICES	
ENGINEER: MMI		BLOCK TITLE:	
LAST MODIFIED BY: MMI		block_rf	
Mon May 11 16:30:09 2015			
MOTOROLA CONFIDENTIAL RESTRICTED		PROJECT NAME	REV
THE DRAWING ON THIS PRINT AND INFORMATION THEREWITH ARE PROPRIETARY TO MOTOROLA AND SHALL NOT BE USED OR DISCUSSED IN WHOLE OR IN PART WITHOUT MOTOROLA'S CONSENT. © COPYRIGHT, MOTOROLA. THIS DOES NOT IMPLY PUBLICATION		B 84016407.cpm	01
		CAD FILE NAME:	PAGE 43 OF 47

RFFE:LBPA

REF 7400-7499

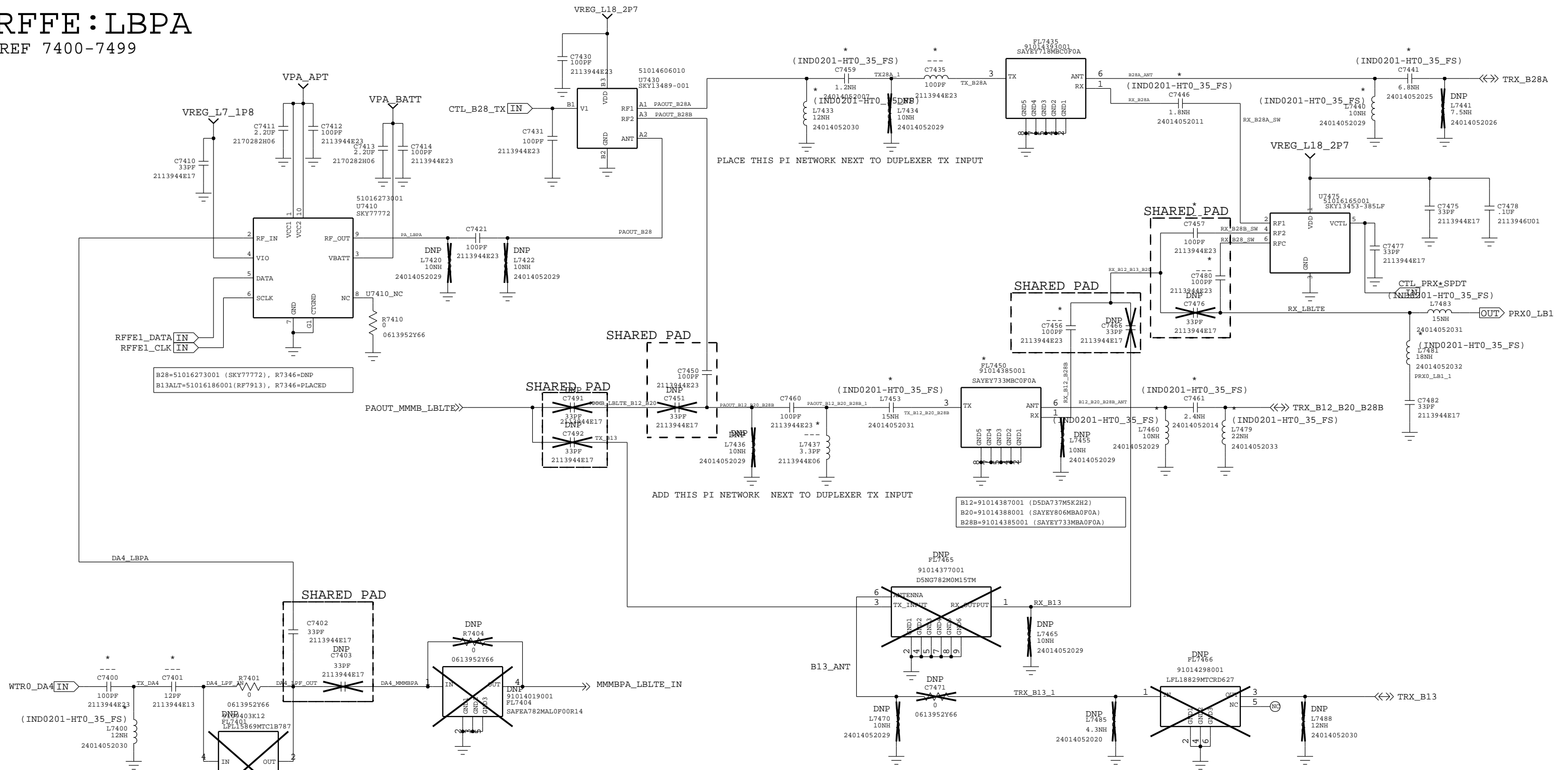

APPROVALS		MOTOROLA MOBILE DEVICES	
ENGINEER: MMI		BLOCK TITLE:	
LAST MODIFIED BY: MMI Mon May 11 16:30:11 2015		block_rffe	
MOTOROLA CONFIDENTIAL RESTRICTED		PROJECT NAME	REV
THE DRAWING ON THIS PRINT AND INFORMATION THERWITH ARE PROPRIETARY TO MOTOROLA AND SHALL NOT BE USED OR DISCUSSED IN WHOLE OR IN PART WITHOUT MOTOROLA'S CONSENT. © COPYRIGHT, MOTOROLA. THIS DOES NOT IMPLY PUBLICATION		B 84016407.cpm	01
		CAD FILE NAME:	
		PAGE 44 OF 47	

RFFE:QFE2101
REF 8000-8020

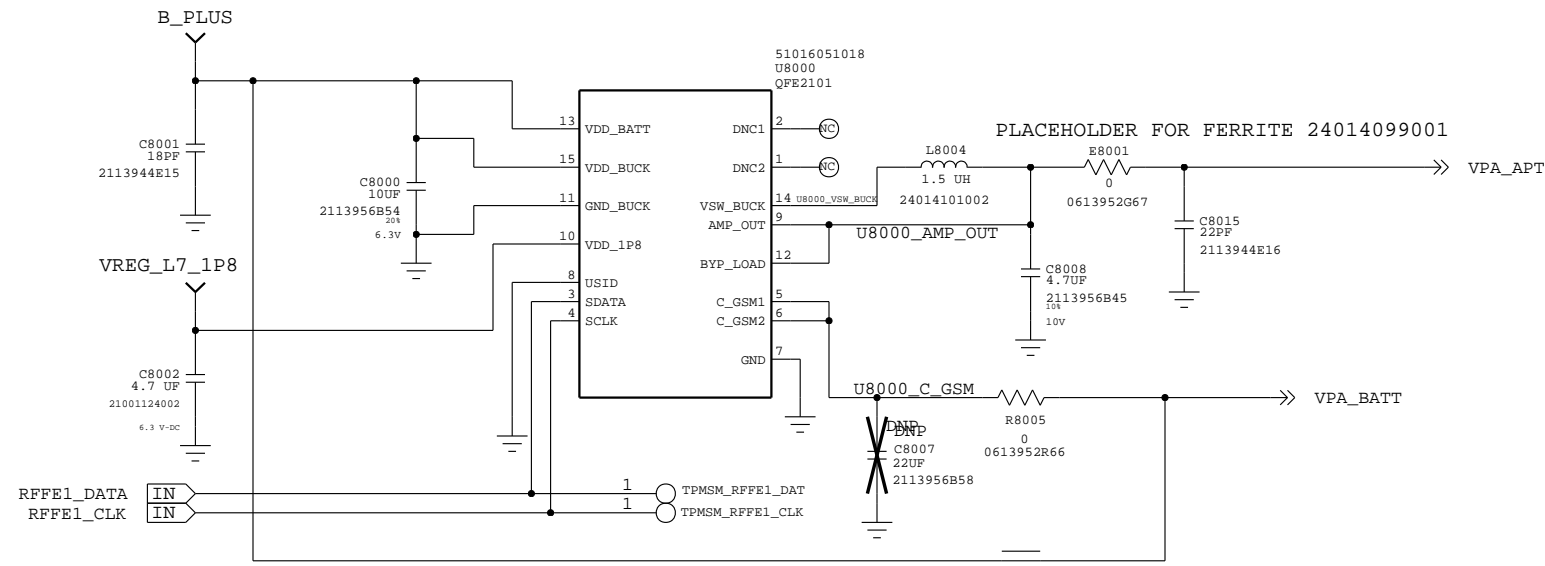

BYPASS OPTION FOR VPA_VBATT
DNP APPROPRIATELY

APPROVALS		MOTOROLA MOBILE DEVICES	
ENGINEER: MMI		BLOCK TITLE:	
LAST MODIFIED BY: MMI Mon May 11 16:30:17 2015		block_rffe	
MOTOROLA CONFIDENTIAL RESTRICTED <small>THE DRAWING ON THIS PRINT AND INFORMATION THEREWITH ARE PROPRIETARY TO MOTOROLA AND SHALL NOT BE USED OR DISCUSSED IN WHOLE OR IN PART WITHOUT MOTOROLA'S CONSENT. © COPYRIGHT, MOTOROLA. THIS DOES NOT IMPLY PUBLICATION</small>		PROJECT NAME B 84016407.cpm	REV 01
		CAD FILE NAME:	
		PAGE 45 OF 47	

RFFE: DIVERSITY

REF 7500-7649

REVISIONS				
REV	ECN	DESCRIPTION	MADE BY	APPROVED
		(IND0201-HT0_35_FS)		
		(IND0201-HT0_35_FS)		
		(IND0201-HT0_35_FS)		

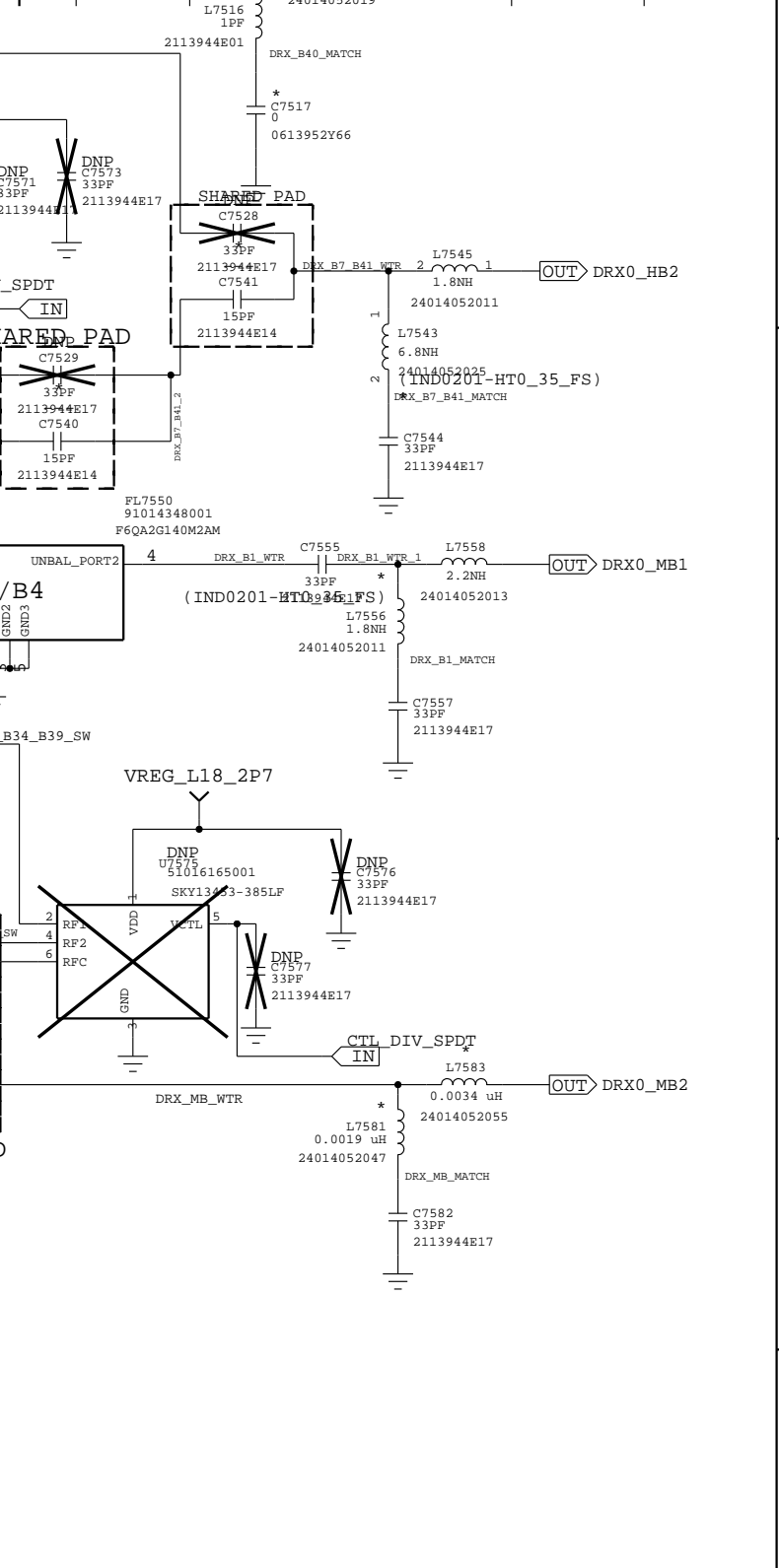
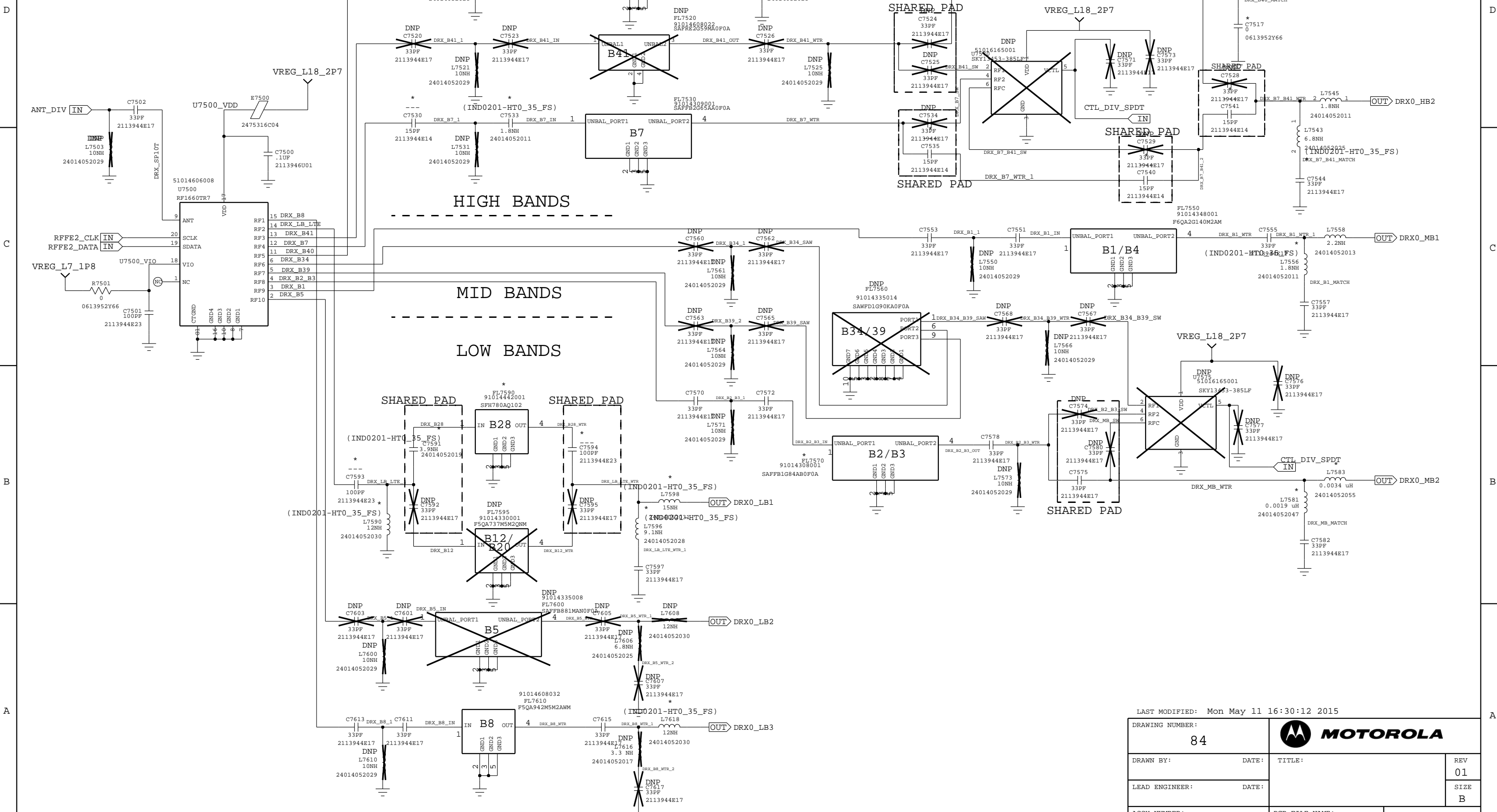

LAST MODIFIED: Mon May 11 16:30:12 2015

DRAWING NUMBER: 84			
DRAWN BY:	DATE:	TITLE:	REV 01
LEAD ENGINEER:	DATE:		SIZE B
ASSY NUMBER:	PCB FILE NAME:	PAGE 46 OF 47	

RFFE: GPS

REF 7650-7699

GPS

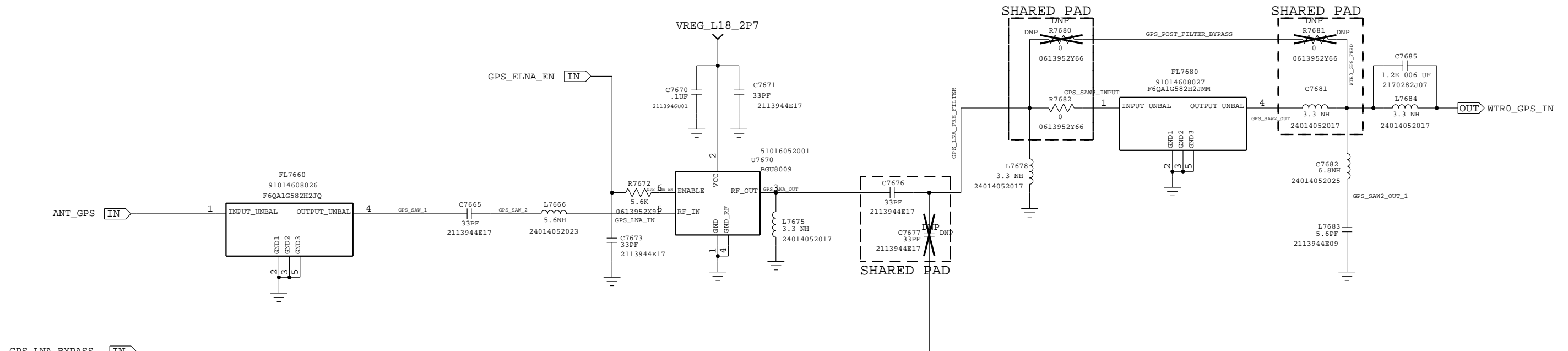

APPROVALS		MOTOROLA MOBILE DEVICES	
ENGINEER: MMI		BLOCK TITLE:	
LAST MODIFIED BY: MMI		block_rffe	
<p>Med May 17 08:38:08 2013</p> <p>MOTOROLA CONFIDENTIAL RESTRICTED</p> <p>THE DRAWING ON THIS PRINT AND INFORMATION THEREWITH ARE PROPRIETARY TO MOTOROLA AND SHALL NOT BE USED OR DISCUSSED IN WHOLE OR IN PART WITHOUT MOTOROLA'S CONSENT. © COPYRIGHT, MOTOROLA. THIS DOES NOT IMPLY PUBLICATION</p>		PROJECT NAME B 84016407.cpm	REV 01
		CAD FILE NAME:	
		PAGE 47 OF 47	