

# QUANTUM RevA TOP

## BASEAD ON SYSTEM 3.0

### LEXINGTON 12-12-2013 RELEASE

REVISIONS				
ZONE	LTR	DESCRIPTION	DATE	APPROVED

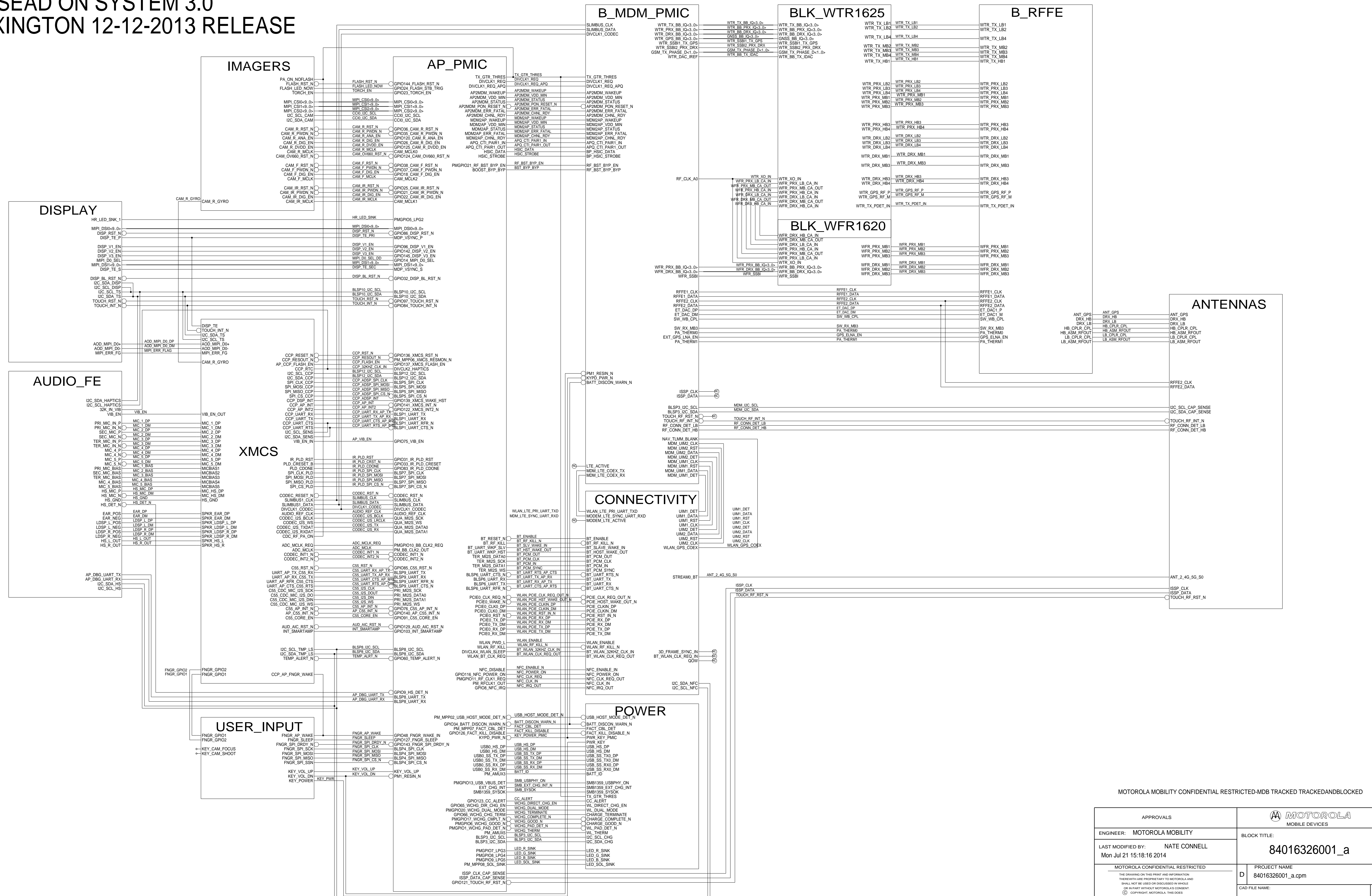

APPROVALS		MOTOROLA MOBILE DEVICES	
ENGINEER:	MOTOROLA MOBILITY	BLOCK TITLE:	84016326001_a
LAST MODIFIED BY:	NATE CONNELL	PROJECT NAME:	84016326001_a.cpm
Mon Jul 21 15:18:16 2014		REV	01
MOTOROLA CONFIDENTIAL RESTRICTED		CAD FILE NAME:	
THE DRAWING ON THIS PRINT AND INFORMATION THEREON ARE PROPRIETARY TO MOTOROLA AND SHALL NOT BE USED OR DISCLOSED IN WHOLE OR IN PART WITHOUT MOTOROLA'S CONSENT. © COPYRIGHT, MOTOROLA, THIS DOES NOT APPLY TO PUBLICATION.			

# QUANTUM ME/SHIELDS

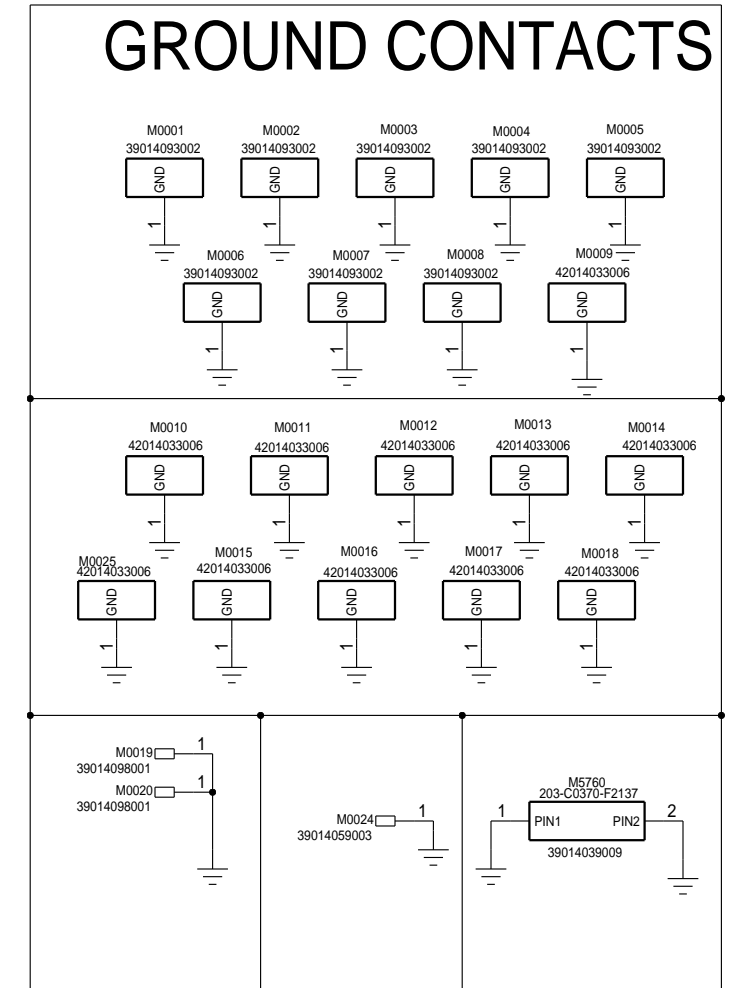
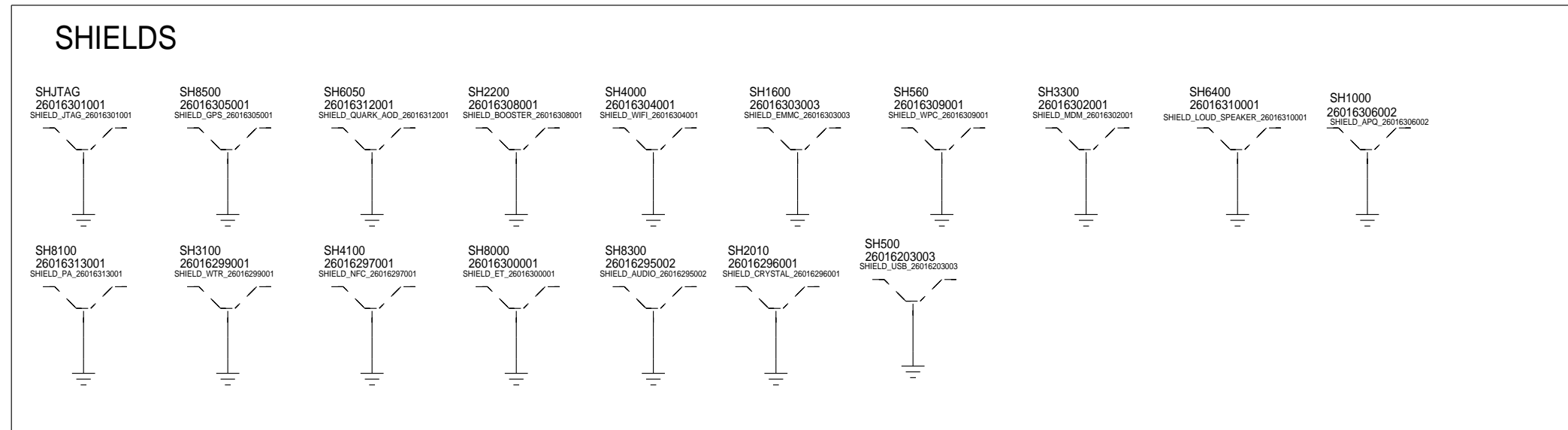

## LEXINGTON REFERENCE DESIGNATOR RANGES BY BLOCK

- 000 - 499: ANTENNA
- 500 - 599: USER INPUT
- 600 - 799: POWER
- 1000-2999: APQ8084 + PMA8084
- 3000-3199: WFR1620 + WTR1605
- 3200-3999: MDM9625 + PM8019
- 4000-4499: CONNECTIVITY
- 4500-4999: AUDIO FE
- 5000-5499: DISPLAY
- 5500-5999: CAMERA
- 6000-6999: XMCS
- 7000-8999: RFFE
- 9000-9999: PRODUCT-SPECIFIC (FILTERING, 100PF CAPS)

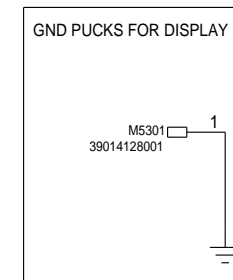
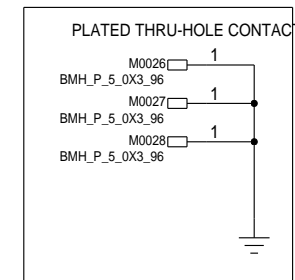

MOTOROLA MOBILITY CONFIDENTIAL RESTRICTED-MDB TRACKED TRACKEDANDBLOCKED

APPROVALS			
ENGINEER:		BLOCK TITLE:	
LAST MODIFIED BY: Tue Aug 12 08:53:14 2014		84016326001_a	
MOTOROLA CONFIDENTIAL RESTRICTED		PROJECT NAME	REV
THE DRAWING ON THIS PRINT AND INFORMATION THEREWITH ARE PROPRIETARY TO MOTOROLA AND SHALL NOT BE USED OR DISCUSSED IN WHOLE OR IN PART WITHOUT MOTOROLA'S CONSENT. © COPYRIGHT, MOTOROLA. THIS DOES NOT IMPLY PUBLICATION		B 84016326001_a.cpm	01
		CAD FILE NAME:	PAGE 2 OF 77

# RFFE: TRX SWITCH

## REF 7100-8499

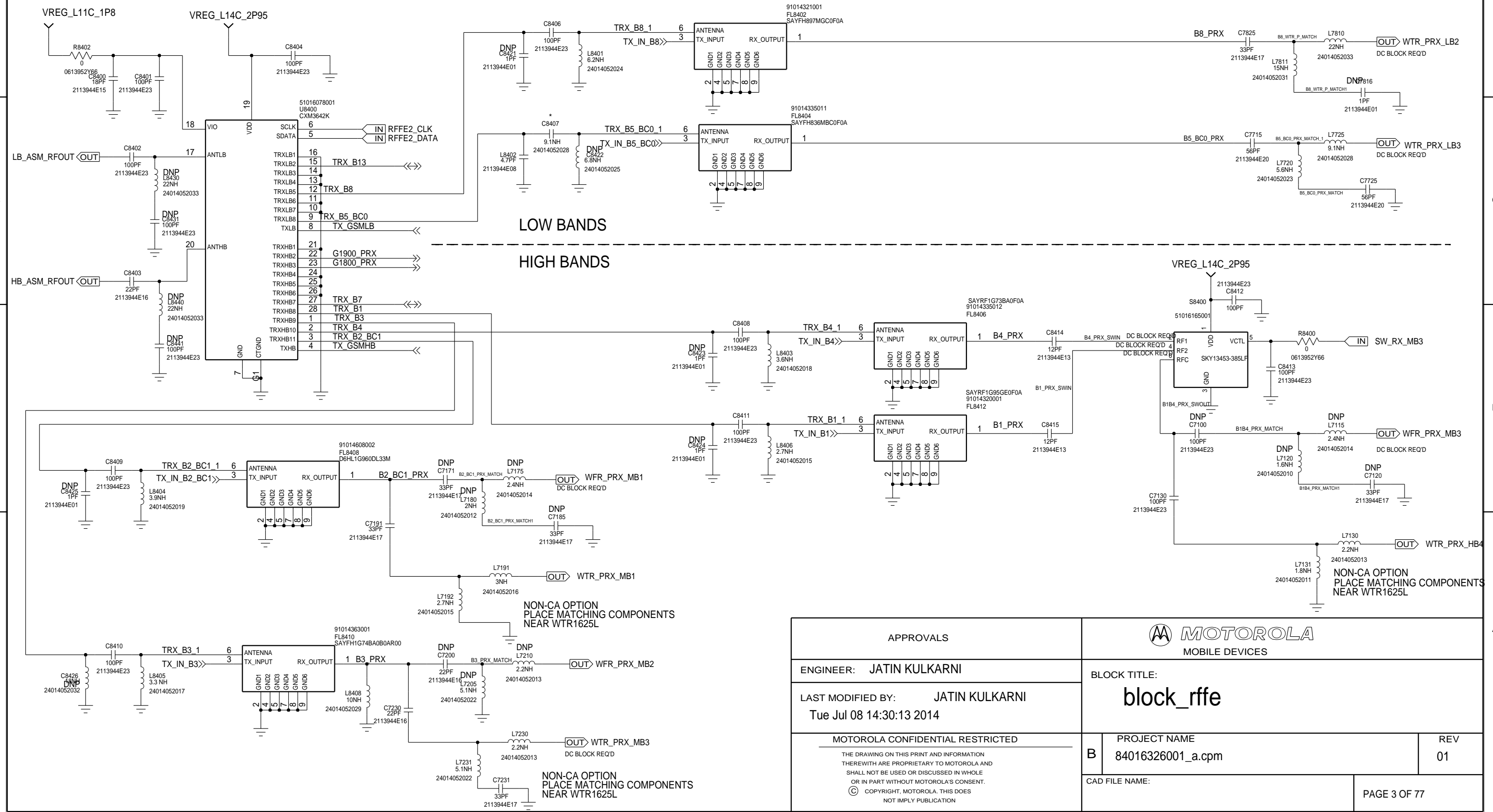



APPROVALS		 <b>MOTOROLA</b> MOBILE DEVICES	
ENGINEER: JATIN KULKARNI		BLOCK TITLE: <b>block_rfe</b>	
LAST MODIFIED BY: JATIN KULKARNI Tue Jul 08 14:30:13 2014		PROJECT NAME <b>B 84016326001_a.cpm</b>	
MOTOROLA CONFIDENTIAL RESTRICTED <small>THE DRAWING ON THIS PRINT AND INFORMATION THEREWITH ARE PROPRIETARY TO MOTOROLA AND SHALL NOT BE USED OR DISCUSSED IN WHOLE OR IN PART WITHOUT MOTOROLA'S CONSENT.          © COPYRIGHT, MOTOROLA. THIS DOES NOT IMPLY PUBLICATION</small>		CAD FILE NAME:	REV <b>01</b>
		PAGE 3 OF 77	

# RFFE: PRX GSM1800/GSM1900

REF 7100-8499

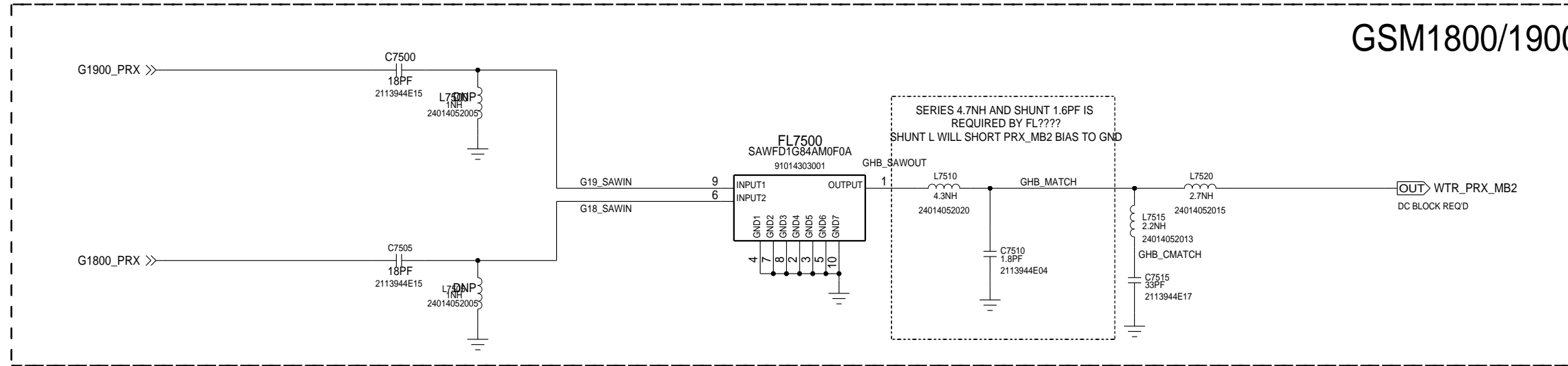
## GSM1800/1900



APPROVALS		 <b>MOTOROLA</b> MOBILE DEVICES	
ENGINEER: JATIN KULKARNI		BLOCK TITLE:	
LAST MODIFIED BY: JATIN KULKARNI Thu Jun 05 15:26:04 2014		<b>block_rfe</b>	
MOTOROLA CONFIDENTIAL RESTRICTED <small>THE DRAWING ON THIS PRINT AND INFORMATION THEREWITH ARE PROPRIETARY TO MOTOROLA AND SHALL NOT BE USED OR DISCUSSED IN WHOLE OR IN PART WITHOUT MOTOROLA'S CONSENT.          © COPYRIGHT, MOTOROLA. THIS DOES NOT IMPLY PUBLICATION</small>		PROJECT NAME <b>B 807463260001_a.cpm</b>	REV <b>01</b>
		CAD FILE NAME:	
		PAGE 4 OF 77	

# RFFE: APT/ET

REF 8000-8099

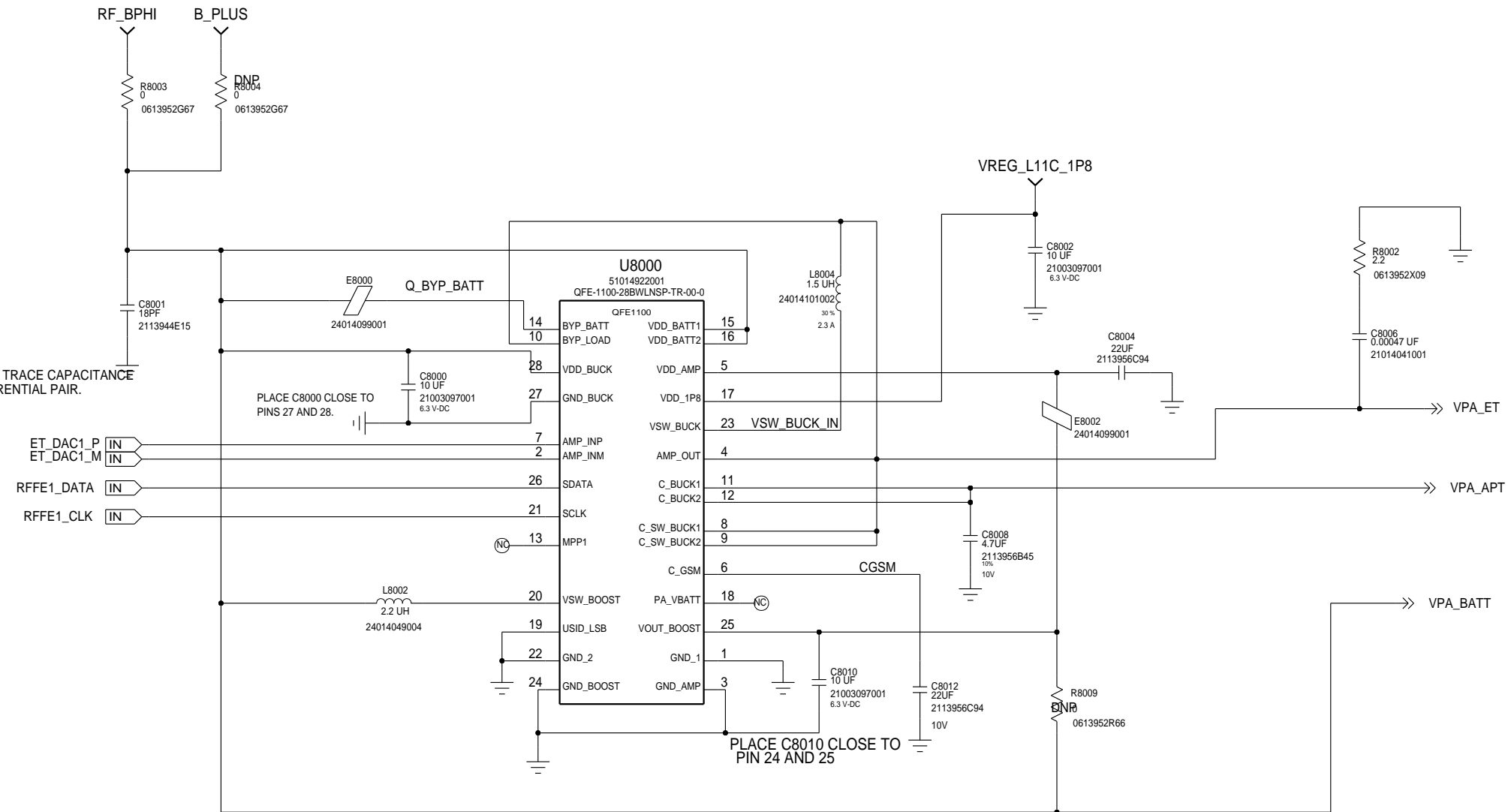

QCOM'S NOTE:  
RECOMMENDED MAXIMUM TRACE CAPACITANCE  
IS 5PF FOR ET\_DAC DIFFERENTIAL PAIR.

IF USING ET, PLACE R8010 AND R8011  
IF NOT USING ET, DNP R8010 AND R8011

### QCOM'S NOTES:

- QFE1100 ES2 PIN 13 CONNECTION TO PMIC HKADC IS FOR ET ENVELOP GAIN CALIBRATION AND QFE1100 INTERNAL TEMPERATURE SENSOR READING.
- WHEN QFE1100 ES2 PIN13 IS CONNECTED TO PMIC HKADC, PULL-UP RESISTOR ON BB SIDED SHOULD BE REMOVED FOR PM8019 (MDM9X25), OR SOFTWARE SHOULD DISABLE PULL-UP PULL-UP ON PM8941, PIN195 (MSM8974).
- FULL SUPPORT OF LOW VOLTAGE BATTERY WITH LTE 1RB IS AVAILABLE ON ES2 SAMPLE (FEB. 2013). ES2 COMBINED WITH L8001 AND C8005 CHANGE SUPPORTS LOW VOLTAGE BATTERY OVER ALL TECHNOLOGIES WHICH SUPPORT ET.

PLEASE REFER TO 80-NA681-5 AND 80-NA681-91 FOR QFE1100  
CRITICAL LAYOUT GUIDE LINES IN MORE DETAIL.

APPROVALS		<b>MOTOROLA</b> MOBILE DEVICES	
ENGINEER:		BLOCK TITLE:	
LAST MODIFIED BY: Thu Jun 05 15:26:05 2014		<b>block_rfe</b>	
MOTOROLA CONFIDENTIAL RESTRICTED <small>THE DRAWING ON THIS PRINT AND INFORMATION THEREWITH ARE PROPRIETARY TO MOTOROLA AND SHALL NOT BE USED OR DISCUSSED IN WHOLE OR IN PART WITHOUT MOTOROLA'S CONSENT. © COPYRIGHT, MOTOROLA. THIS DOES NOT IMPLY PUBLICATION</small>		PROJECT NAME <b>B 80746326001_a.cpm</b>	REV <b>01</b>
		CAD FILE NAME:	
		PAGE 5 OF 77	

# RFFE: TX MMB PA

REF 8100-8199

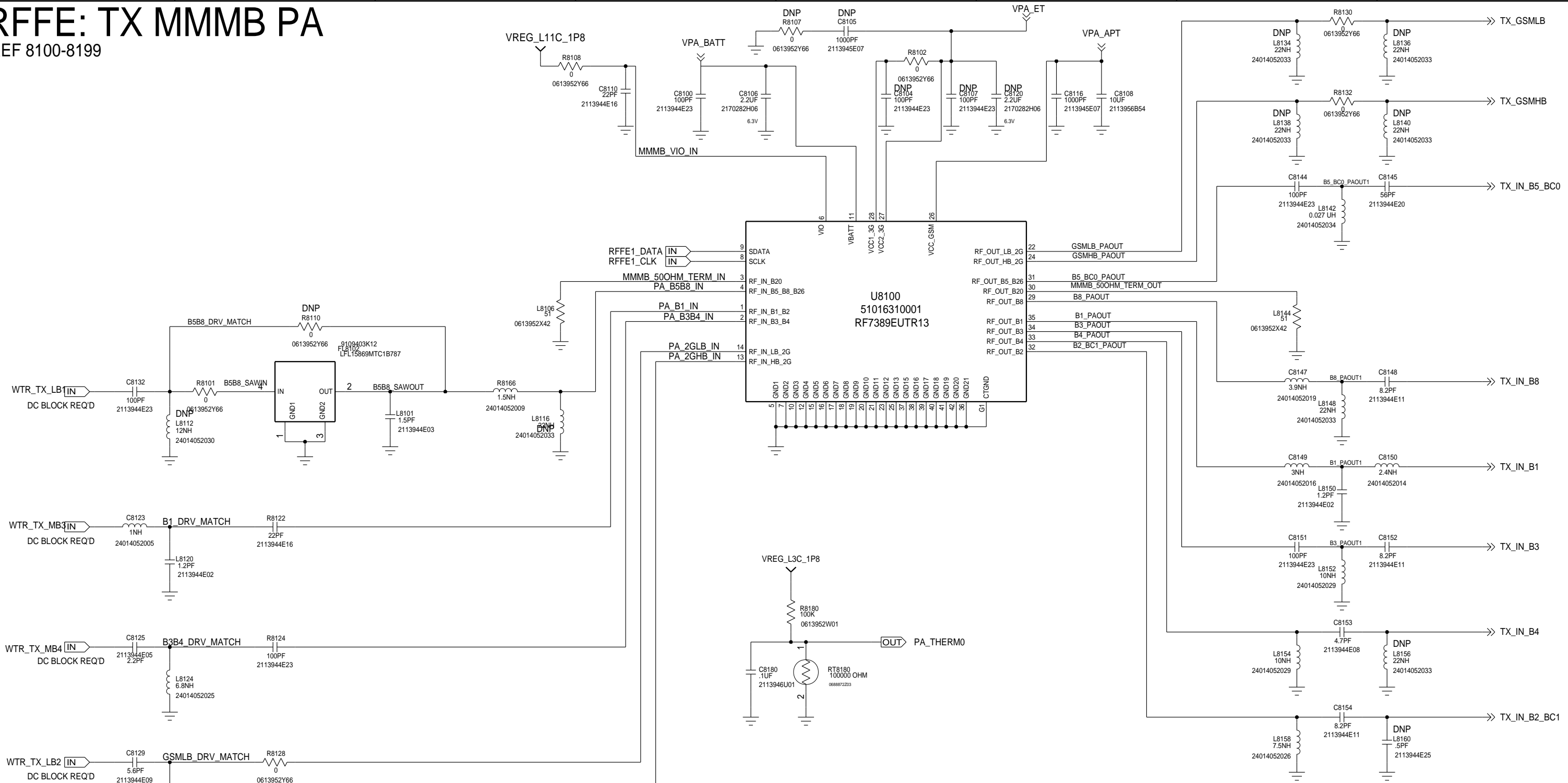

APPROVALS	
ENGINEER:	JATIN KULKARNI
LAST MODIFIED BY:	JATIN KULKARNI
	Thu Jun 05 15:26:06 2014
MOTOROLA CONFIDENTIAL RESTRICTED	
<small>THE DRAWING ON THIS PRINT AND INFORMATION THEREWITH ARE PROPRIETARY TO MOTOROLA AND SHALL NOT BE USED OR DISCUSSED IN WHOLE OR IN PART WITHOUT MOTOROLA'S CONSENT. © COPYRIGHT, MOTOROLA. THIS DOES NOT IMPLY PUBLICATION</small>	

BLOCK TITLE:	
<h2>block_rfe</h2>	
PROJECT NAME	REV
B 807463260001_a.cpm	01
CAD FILE NAME:	
PAGE 6 OF 77	

# RFFE: TX B7

REF 7100-8299

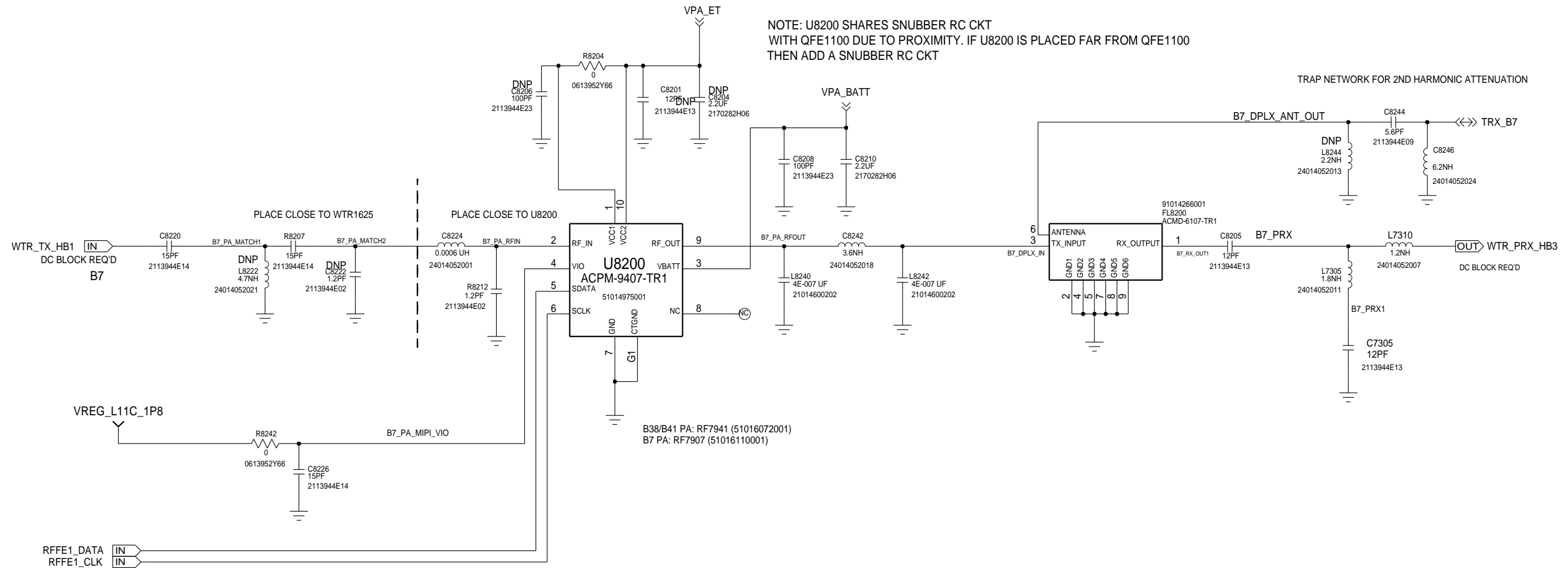

**NOTES:**  
 DATE: 2/7/2013  
 - THE MATCHING COMPONENTS ARE TEMPORARY PLACE HOLDERS ONLY.  
 THE EXACT COMPONENTS WILL NEED TO BE DEFINED BEFORE RELEASED.

APPROVALS		<b>MOTOROLA</b> MOBILE DEVICES	
ENGINEER:		BLOCK TITLE: <b>block_rfe</b>	
LAST MODIFIED BY: Wed Jul 16 15:10:23 2014		PROJECT NAME B 80746326001_a.cpm	
MOTOROLA CONFIDENTIAL RESTRICTED <small>THE DRAWING ON THIS PRINT AND INFORMATION THEREWITH ARE PROPRIETARY TO MOTOROLA AND SHALL NOT BE USED OR DISCUSSED IN WHOLE OR IN PART WITHOUT MOTOROLA'S CONSENT.                  © COPYRIGHT, MOTOROLA. THIS DOES NOT IMPLY PUBLICATION</small>		REV <b>01</b>	
		CAD FILE NAME: PAGE 7 OF 77	





# RFFE: DRX ANTENNA SWITCH

REF 7100-8499

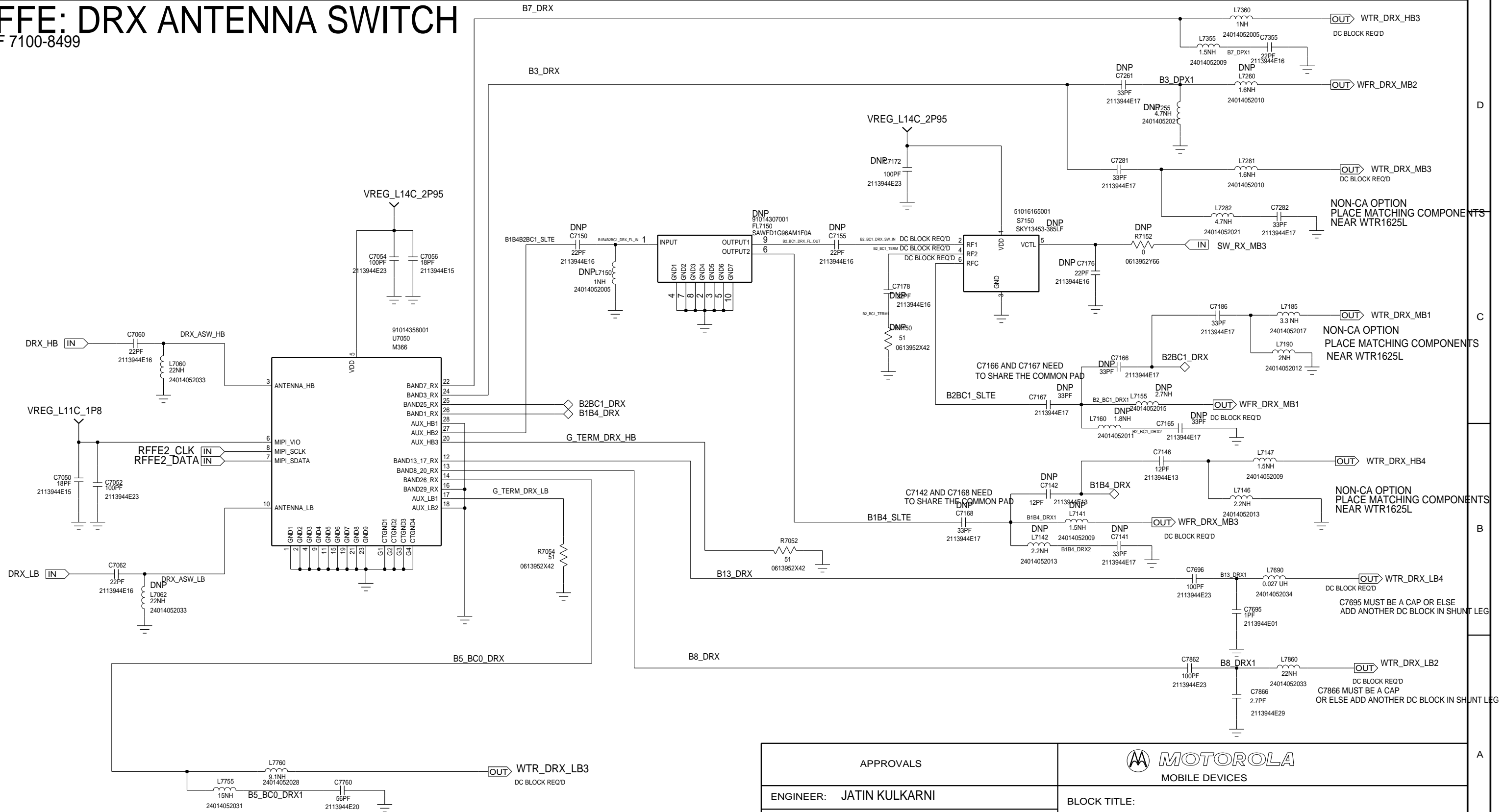

APPROVALS		<b>MOTOROLA</b> MOBILE DEVICES	
ENGINEER: JATIN KULKARNI		BLOCK TITLE: <b>block_rfe</b>	
LAST MODIFIED BY: JATIN KULKARNI Tue Jul 08 14:31:11 2014		PROJECT NAME <b>80046326001_a.cpm</b>	
MOTOROLA CONFIDENTIAL RESTRICTED <small>THE DRAWING ON THIS PRINT AND INFORMATION THEREWITH ARE PROPRIETARY TO MOTOROLA AND SHALL NOT BE USED OR DISCUSSED IN WHOLE OR IN PART WITHOUT MOTOROLA'S CONSENT. © COPYRIGHT, MOTOROLA. THIS DOES NOT IMPLY PUBLICATION</small>		REV <b>01</b>	
		PAGE 9 OF 77	

# RFFE: GPS

REF : 8500-8549

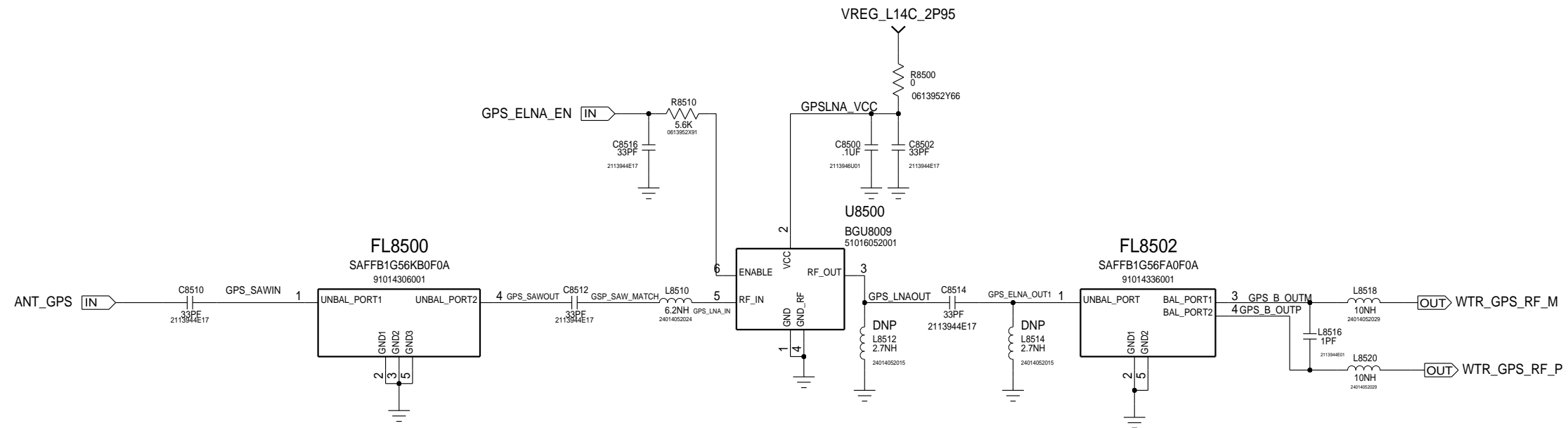

PLACE IN WTR1625 SHIELD

APPROVALS		<b>MOTOROLA</b> MOBILE DEVICES	
ENGINEER:		BLOCK TITLE:	
LAST MODIFIED BY: Tue Jun 24 16:29:14 2014		<b>block_rfe</b>	
MOTOROLA CONFIDENTIAL RESTRICTED <small>THE DRAWING ON THIS PRINT AND INFORMATION THEREWITH ARE PROPRIETARY TO MOTOROLA AND SHALL NOT BE USED OR DISCUSSED IN WHOLE OR IN PART WITHOUT MOTOROLA'S CONSENT.          © COPYRIGHT, MOTOROLA. THIS DOES NOT IMPLY PUBLICATION</small>		PROJECT NAME B 80746326001_a.cpm	REV 01
		CAD FILE NAME:	
		PAGE 10 OF 77	

# RFFE: PDET

REF : 8500-8549

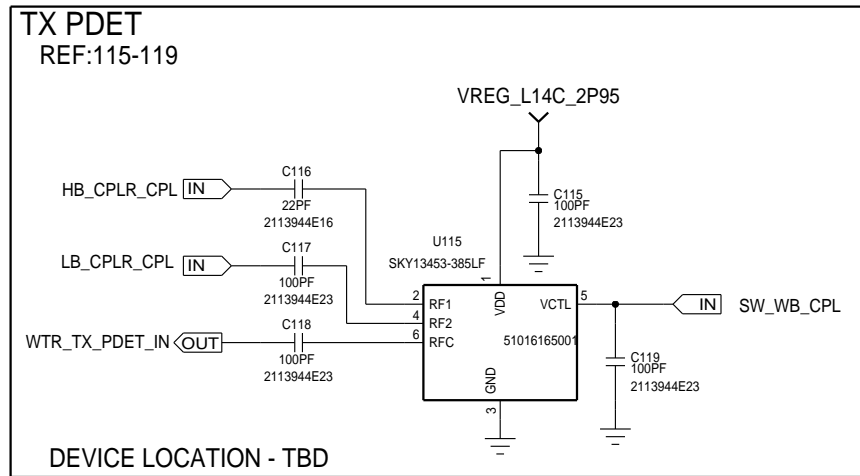

APPROVALS		<b>MOTOROLA</b> MOBILE DEVICES	
ENGINEER:		BLOCK TITLE:	
LAST MODIFIED BY: Thu Jun 05 15:26:09 2014		<b>block_rfe</b>	
MOTOROLA CONFIDENTIAL RESTRICTED <small>THE DRAWING ON THIS PRINT AND INFORMATION THEREWITH ARE PROPRIETARY TO MOTOROLA AND SHALL NOT BE USED OR DISCUSSED IN WHOLE OR IN PART WITHOUT MOTOROLA'S CONSENT.          © COPYRIGHT, MOTOROLA. THIS DOES NOT IMPLY PUBLICATION</small>		PROJECT NAME <b>B</b> 80746326001_a.cpm	REV <b>01</b>
		CAD FILE NAME:	
		PAGE 11 OF 77	

# WFR1620: BB RF

REF 3000-3019

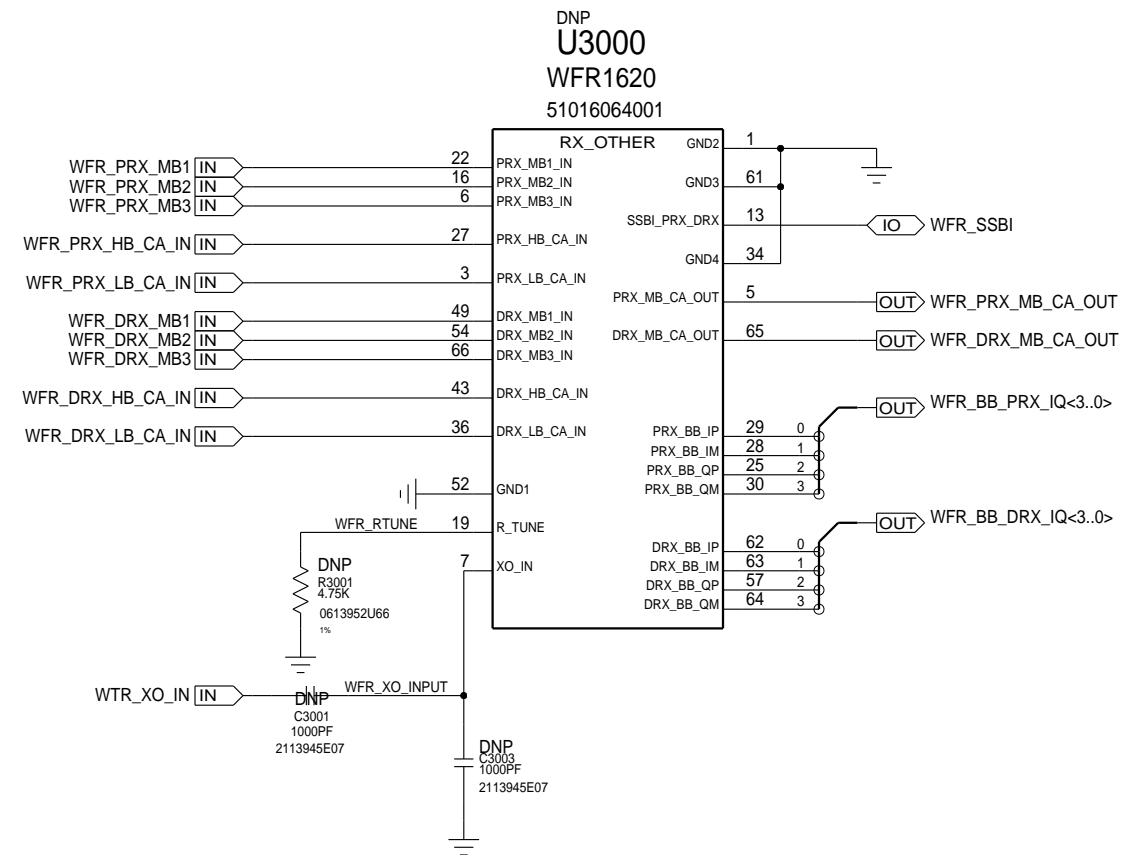

APPROVALS		<b>MOTOROLA</b> MOBILE DEVICES	
ENGINEER:		BLOCK TITLE:	
LAST MODIFIED BY: Thu Jun 05 15:26:02 2014		block_wfr1620	
MOTOROLA CONFIDENTIAL RESTRICTED <small>THE DRAWING ON THIS PRINT AND INFORMATION THEREWITH ARE PROPRIETARY TO MOTOROLA AND SHALL NOT BE USED OR DISCUSSED IN WHOLE OR IN PART WITHOUT MOTOROLA'S CONSENT. © COPYRIGHT, MOTOROLA. THIS DOES NOT IMPLY PUBLICATION</small>		PROJECT NAME <b>B</b> 80746326001_a.cpm	REV <b>01</b>
		CAD FILE NAME:	
		PAGE 12 OF 77	

# WFR1620: POWER

REF 3020-3099

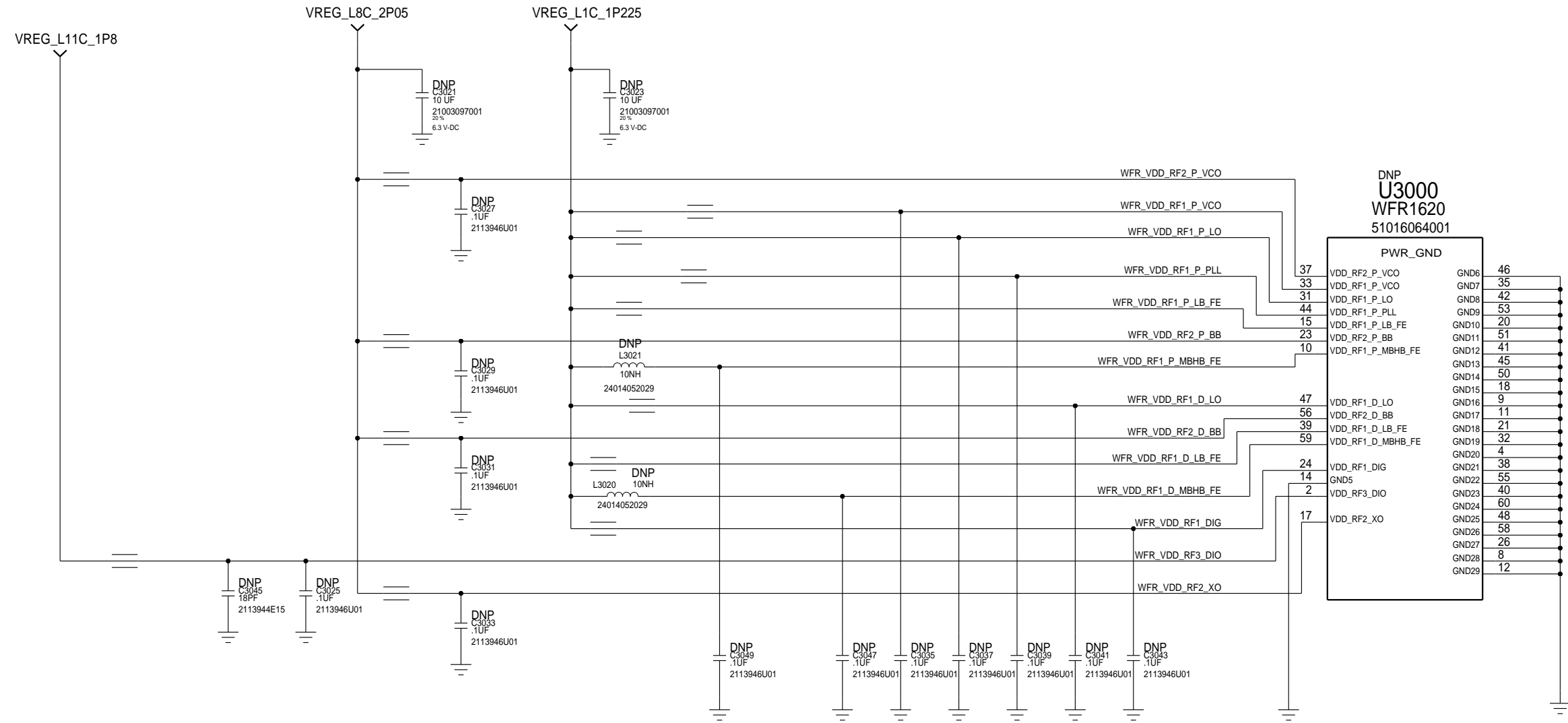

NOTES:  
- THE POWER PIN CONNECTIONS SHOULD EMPLOY STAR CONNECTIONS

APPROVALS		<b>MOTOROLA</b> MOBILE DEVICES	
ENGINEER:		BLOCK TITLE:	
LAST MODIFIED BY: Thu Jun 05 15:26:03 2014		block_wfr1620	
MOTOROLA CONFIDENTIAL RESTRICTED <small>THE DRAWING ON THIS PRINT AND INFORMATION THEREWITH ARE PROPRIETARY TO MOTOROLA AND SHALL NOT BE USED OR DISCUSSED IN WHOLE OR IN PART WITHOUT MOTOROLA'S CONSENT.          © COPYRIGHT, MOTOROLA. THIS DOES NOT IMPLY PUBLICATION</small>		PROJECT NAME <b>B</b> 80746326001_a.cpm	REV <b>01</b>
		CAD FILE NAME:	
		PAGE 13 OF 77	

# WTR1625: TX/GROUND

REF 3100-3109

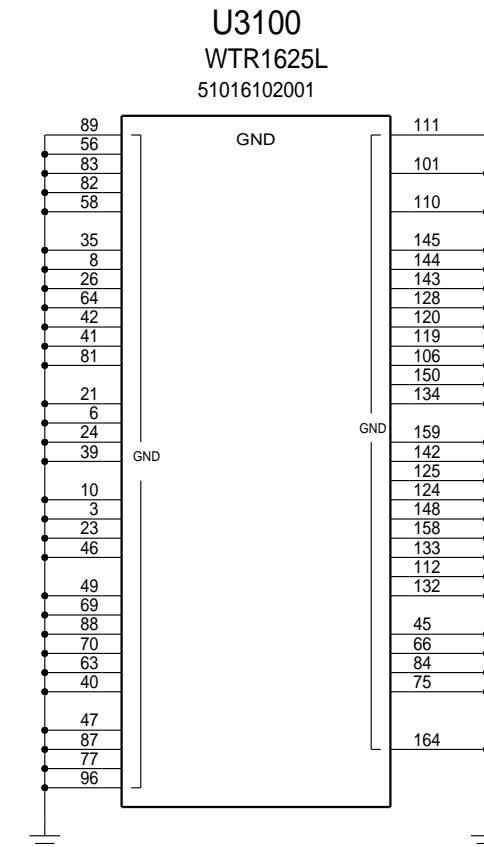
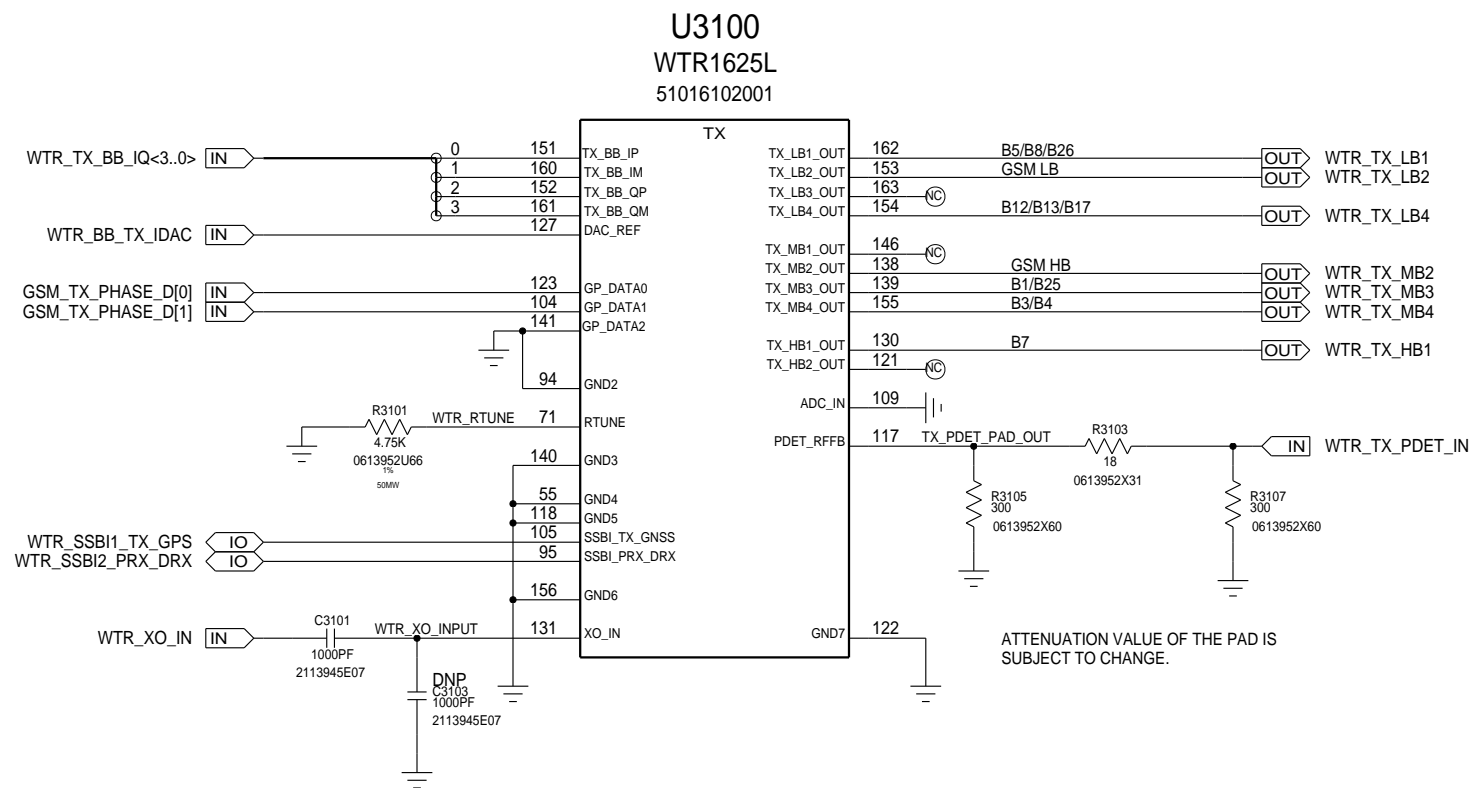

QCOM'S NOTE:  
 WTR/WFR SHARE ONE 19.2 MHZ REFERENCE CLOCK.  
 IT IS RECOMMENDED TO KEEP THE TRACE LENGTH DELTA TO WTR/WFR  
 FROM THE TEEING OFF POINT LESS THAN 5MM FOR BETTER CLOCK SIGNAL INTEGRITY.

APPROVALS		<b>MOTOROLA</b> MOBILE DEVICES	
ENGINEER:		BLOCK TITLE:	
LAST MODIFIED BY: Thu Jun 05 15:26:00 2014		block_wtr1625	
MOTOROLA CONFIDENTIAL RESTRICTED <small>THE DRAWING ON THIS PRINT AND INFORMATION          THEREWITH ARE PROPRIETARY TO MOTOROLA AND          SHALL NOT BE USED OR DISCUSSED IN WHOLE          OR IN PART WITHOUT MOTOROLA'S CONSENT.          © COPYRIGHT, MOTOROLA. THIS DOES          NOT IMPLY PUBLICATION</small>		PROJECT NAME B 80746326001_a.cpm	REV 01
		CAD FILE NAME:	
		PAGE 14 OF 77	

# WTR1625: PRX/DRX/GPS

REF 3110-3119

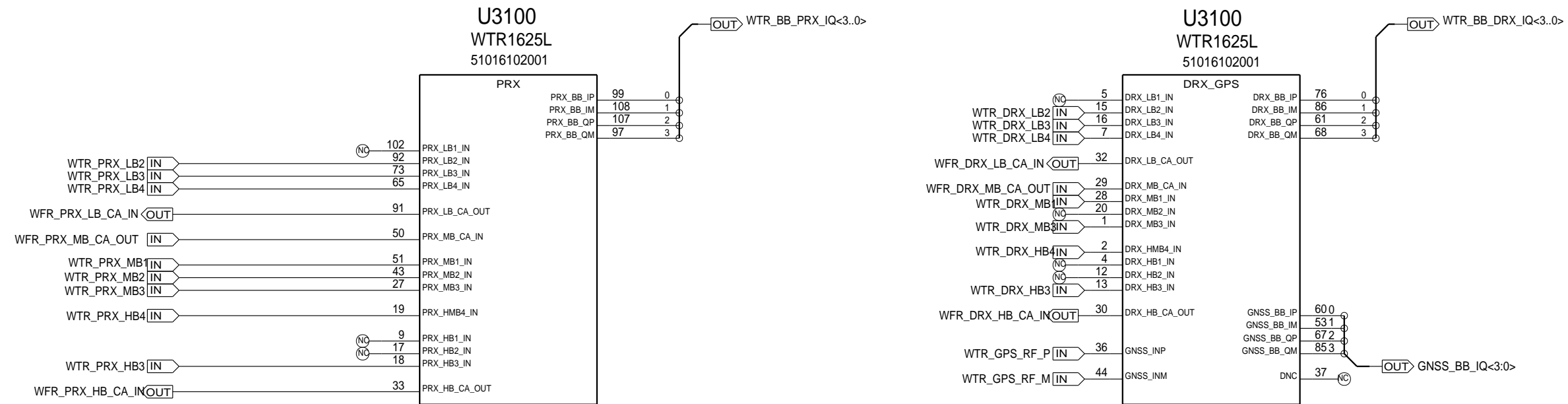

QCOM'S NOTE:  
WTR/WFR CA\_IN/OUT INTERCONNECTION MAXIMUM TRACE LENGTH:  
LOW BAND 12 MM; MID/ HI BAND 10 MM

APPROVALS		<b>MOTOROLA</b> MOBILE DEVICES	
ENGINEER:		BLOCK TITLE:	
LAST MODIFIED BY: Thu Jun 05 15:26:00 2014		<b>block_wtr1625</b>	
MOTOROLA CONFIDENTIAL RESTRICTED <small>THE DRAWING ON THIS PRINT AND INFORMATION THEREWITH ARE PROPRIETARY TO MOTOROLA AND SHALL NOT BE USED OR DISCUSSED IN WHOLE OR IN PART WITHOUT MOTOROLA'S CONSENT. © COPYRIGHT, MOTOROLA. THIS DOES NOT IMPLY PUBLICATION</small>		PROJECT NAME <b>B 80746326001_a.cpm</b>	REV <b>01</b>
		CAD FILE NAME:	
		PAGE 15 OF 77	

# WTR1625: POWER

REF 3120-3199

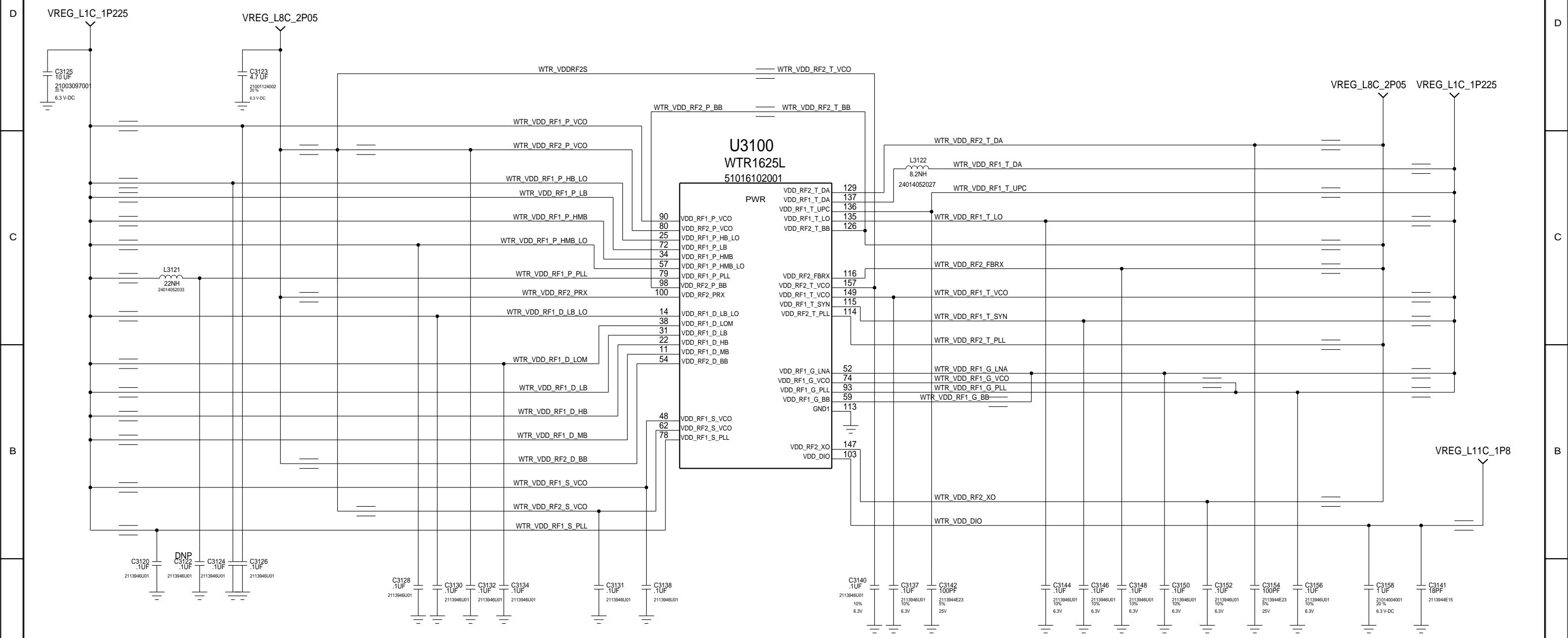

APPROVALS		<b>MOTOROLA</b> MOBILE DEVICES	
ENGINEER:		BLOCK TITLE:	
LAST MODIFIED BY: Thu Jun 05 15:26:01 2014		<b>block_wtr1625</b>	
MOTOROLA CONFIDENTIAL RESTRICTED <small>THE DRAWING ON THIS PRINT AND INFORMATION THEREWITH ARE PROPRIETARY TO MOTOROLA AND SHALL NOT BE USED OR DISCUSSED IN WHOLE OR IN PART WITHOUT MOTOROLA'S CONSENT.          © COPYRIGHT, MOTOROLA. THIS DOES NOT IMPLY PUBLICATION</small>		PROJECT NAME <b>B 80746326</b>	REV <b>01</b>
		CAD FILE NAME:	
		PAGE 16 OF 77	



# ANT: PORTS

REFDES: 000 - 499

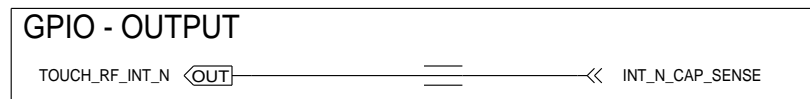
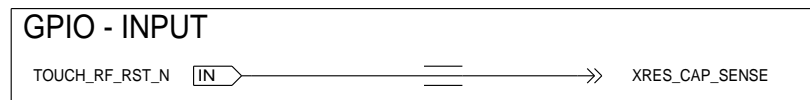
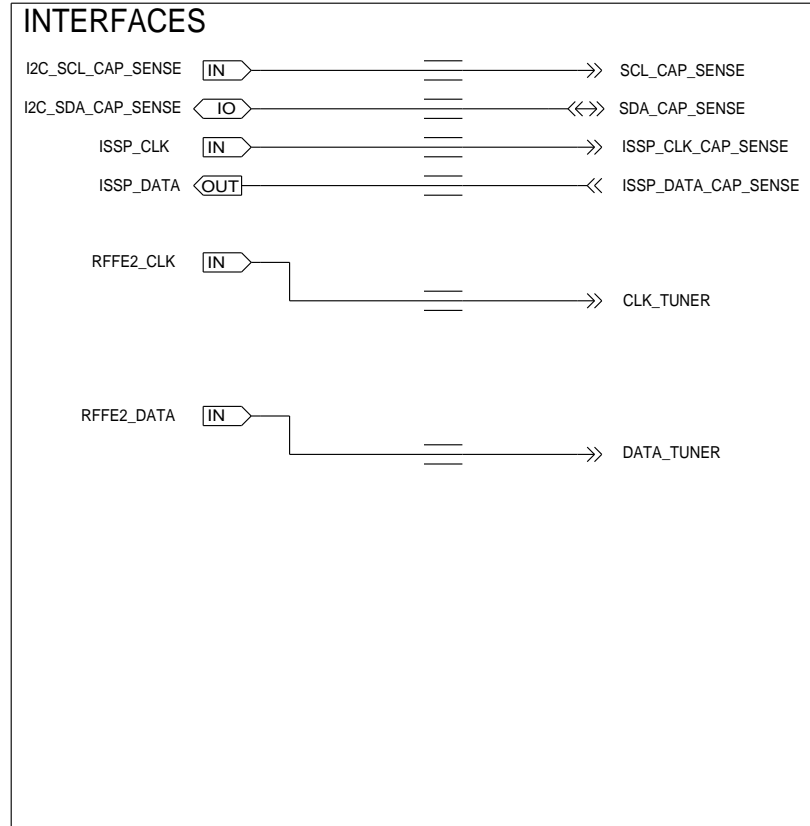
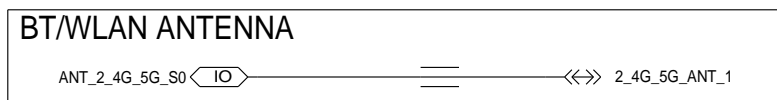
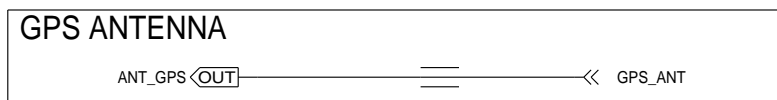
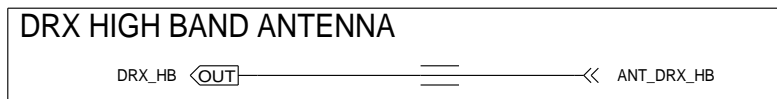
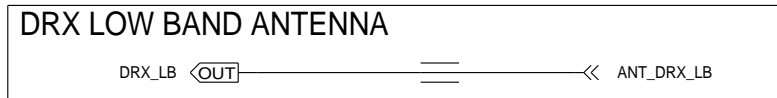
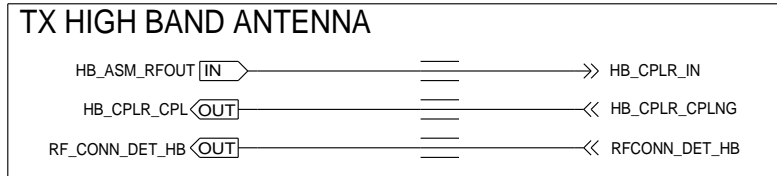
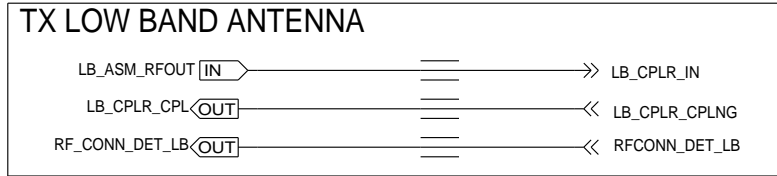
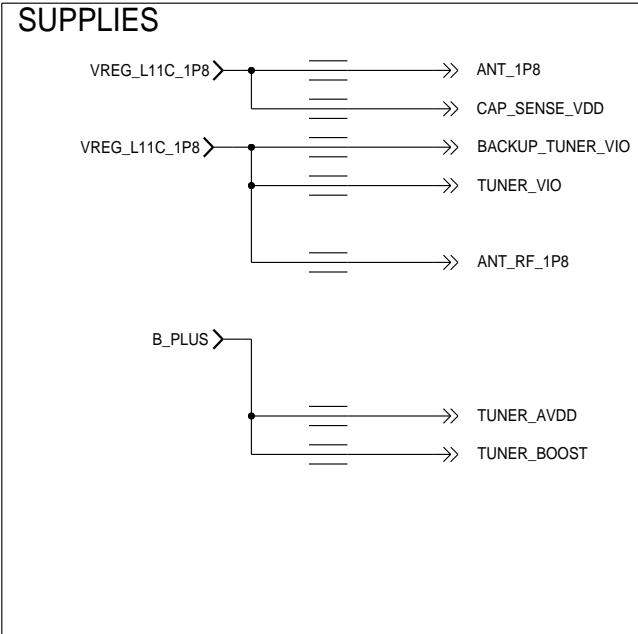

APPROVALS		<b>MOTOROLA</b> MOBILE DEVICES	
ENGINEER: NATE CONNELL		BLOCK TITLE:	
LAST MODIFIED BY: NATE CONNELL Thu Jun 05 15:25:56 2014		<b>antennas</b>	
MOTOROLA CONFIDENTIAL RESTRICTED <small>THE DRAWING ON THIS PRINT AND INFORMATION THEREWITH ARE PROPRIETARY TO MOTOROLA AND SHALL NOT BE USED OR DISCUSSED IN WHOLE OR IN PART WITHOUT MOTOROLA'S CONSENT. © COPYRIGHT, MOTOROLA. THIS DOES NOT IMPLY PUBLICATION</small>		PROJECT NAME	REV
		B 84016326001_a.cpm	01
		CAD FILE NAME:	
		PAGE 17 OF 77	



# ANT: CAP SENSE

REFDES: 200-299

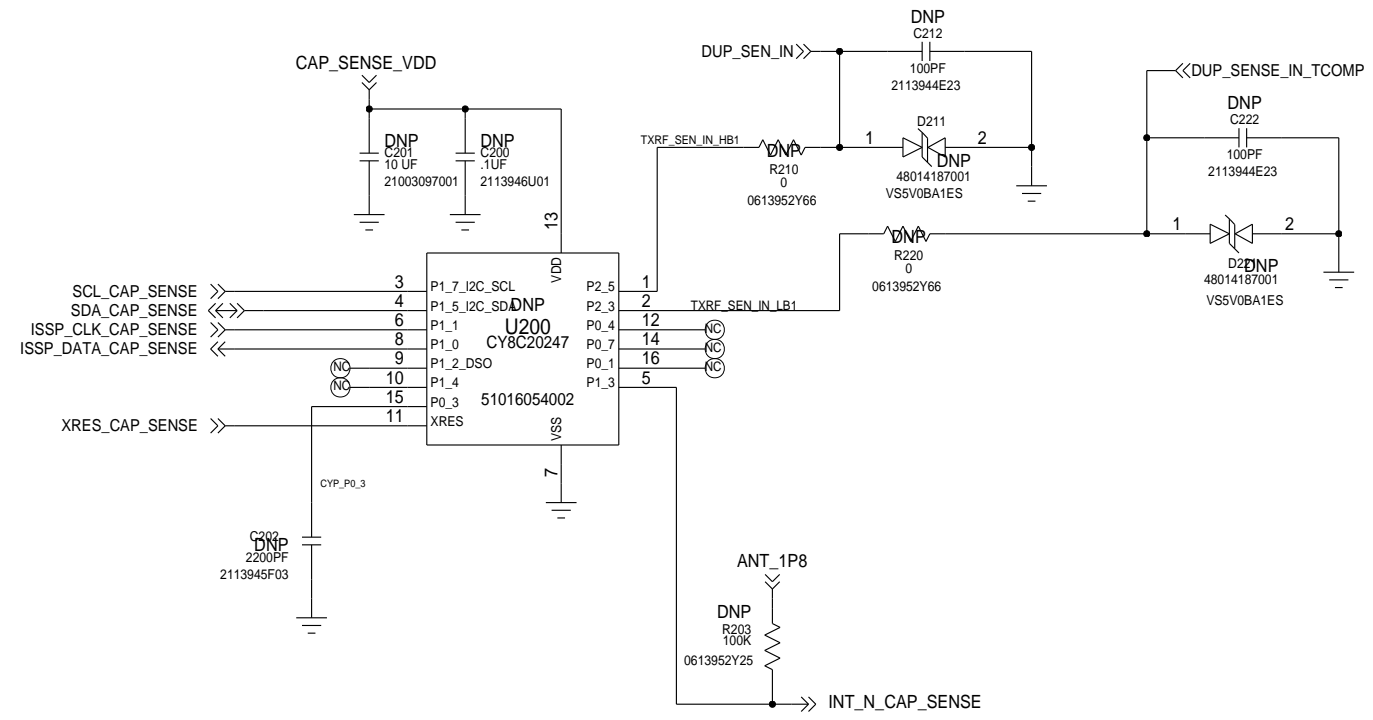

APPROVALS		<b>MOTOROLA</b> MOBILE DEVICES	
ENGINEER: MOTOROLA		BLOCK TITLE:	
LAST MODIFIED BY: MOTOROLA Thu Jun 05 15:25:57 2014		<b>antennas</b>	
MOTOROLA CONFIDENTIAL RESTRICTED <small>THE DRAWING ON THIS PRINT AND INFORMATION THEREWITH ARE PROPRIETARY TO MOTOROLA AND SHALL NOT BE USED OR DISCUSSED IN WHOLE OR IN PART WITHOUT MOTOROLA'S CONSENT. © COPYRIGHT, MOTOROLA. THIS DOES NOT IMPLY PUBLICATION</small>		PROJECT NAME <b>B</b> 84016326001_a.cpm	REV 01
		CAD FILE NAME:	
		PAGE 19 OF 77	

# ANT: TUNERS

REFDES: 300-499

## DIVERSITY RX (RFFE2)

ROOM = DRX\_TUNER  
REF: 350-399

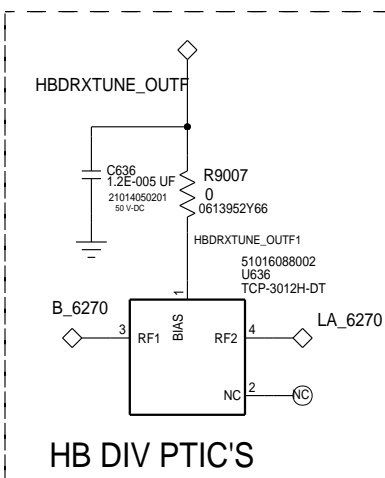
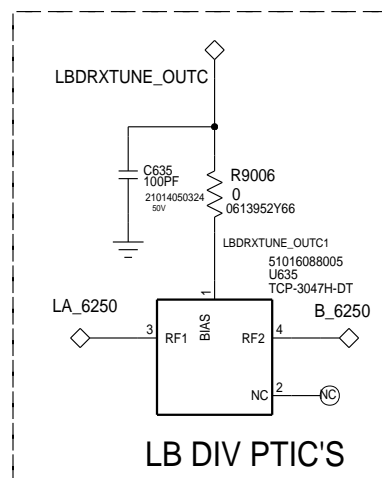
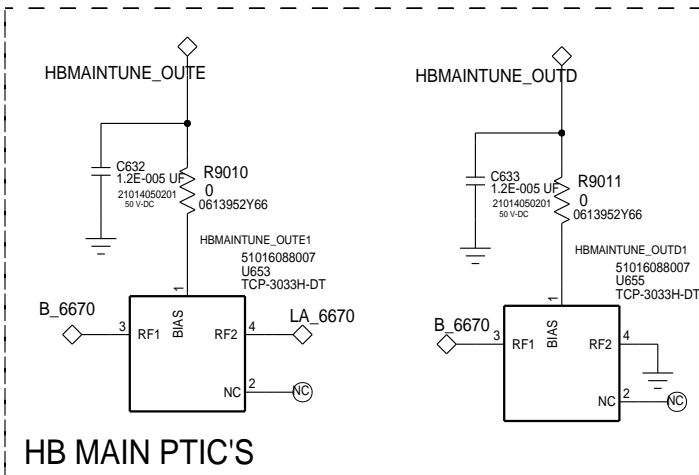
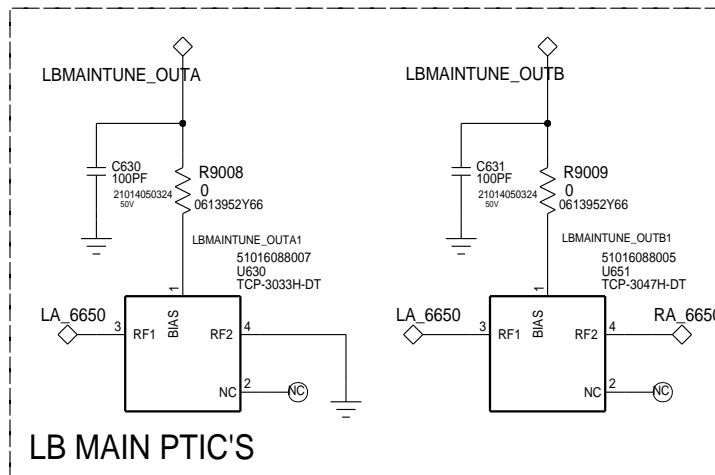
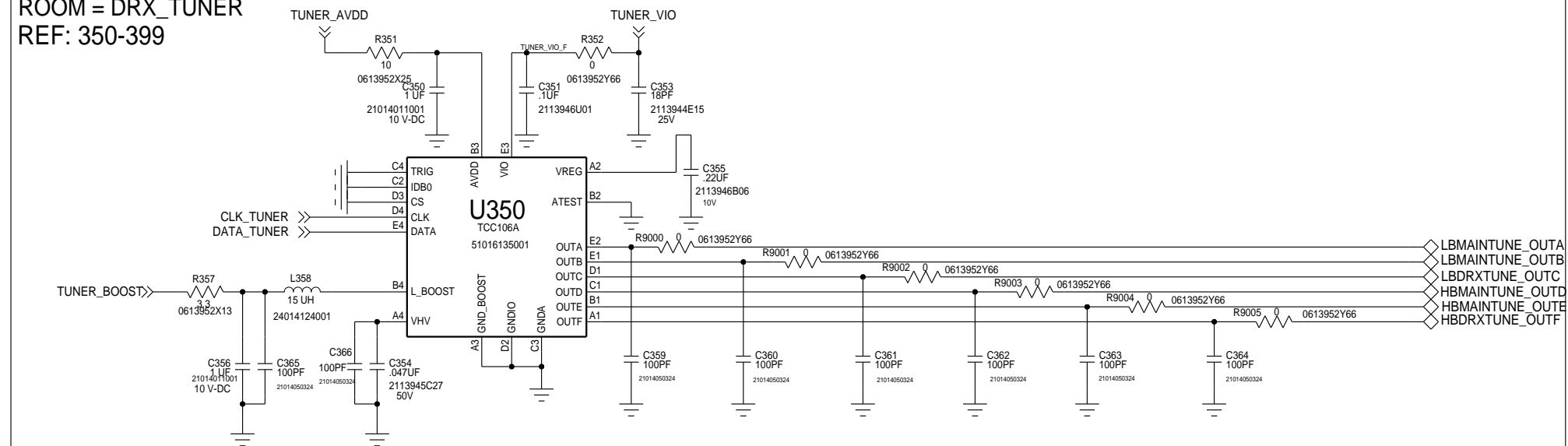

APPROVALS		<b>MOTOROLA</b> MOBILE DEVICES	
ENGINEER: MOTOROLA		BLOCK TITLE:	
LAST MODIFIED BY: MOTOROLA Wed Jun 25 09:29:00 2014		<b>antennas</b>	
MOTOROLA CONFIDENTIAL RESTRICTED <small>THE DRAWING ON THIS PRINT AND INFORMATION THEREWITH ARE PROPRIETARY TO MOTOROLA AND SHALL NOT BE USED OR DISCUSSED IN WHOLE OR IN PART WITHOUT MOTOROLA'S CONSENT. © COPYRIGHT, MOTOROLA. THIS DOES NOT IMPLY PUBLICATION</small>		PROJECT NAME <b>B 84016326001_a.cpm</b>	REV <b>01</b>
		CAD FILE NAME:	
		PAGE 20 OF 77	

# CAM: PORTS

REF 5500-5999

## SUPPLIES

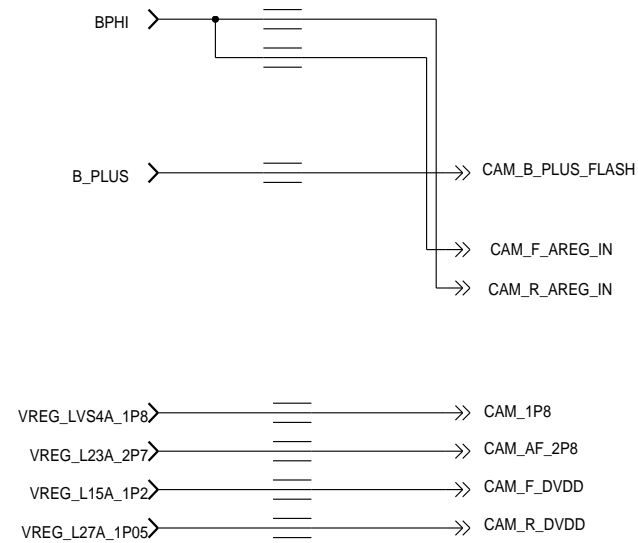

## INPUTS

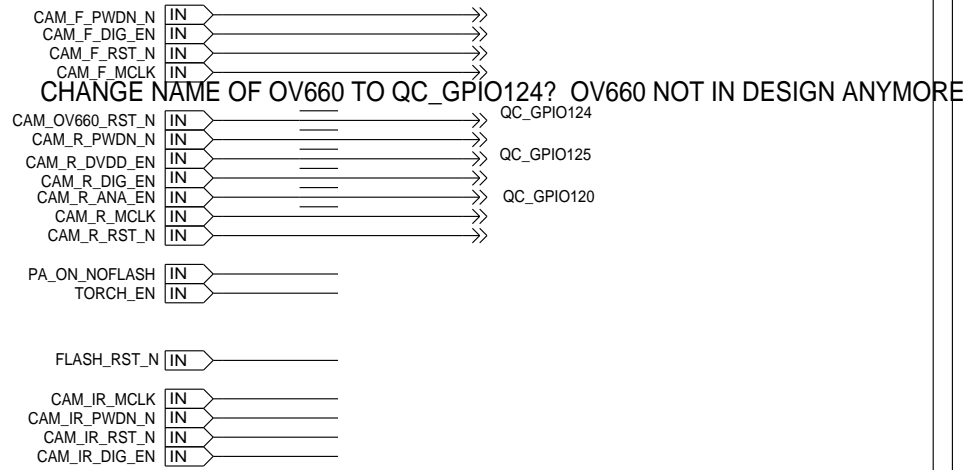

## INTERFACES



## OUTPUTS

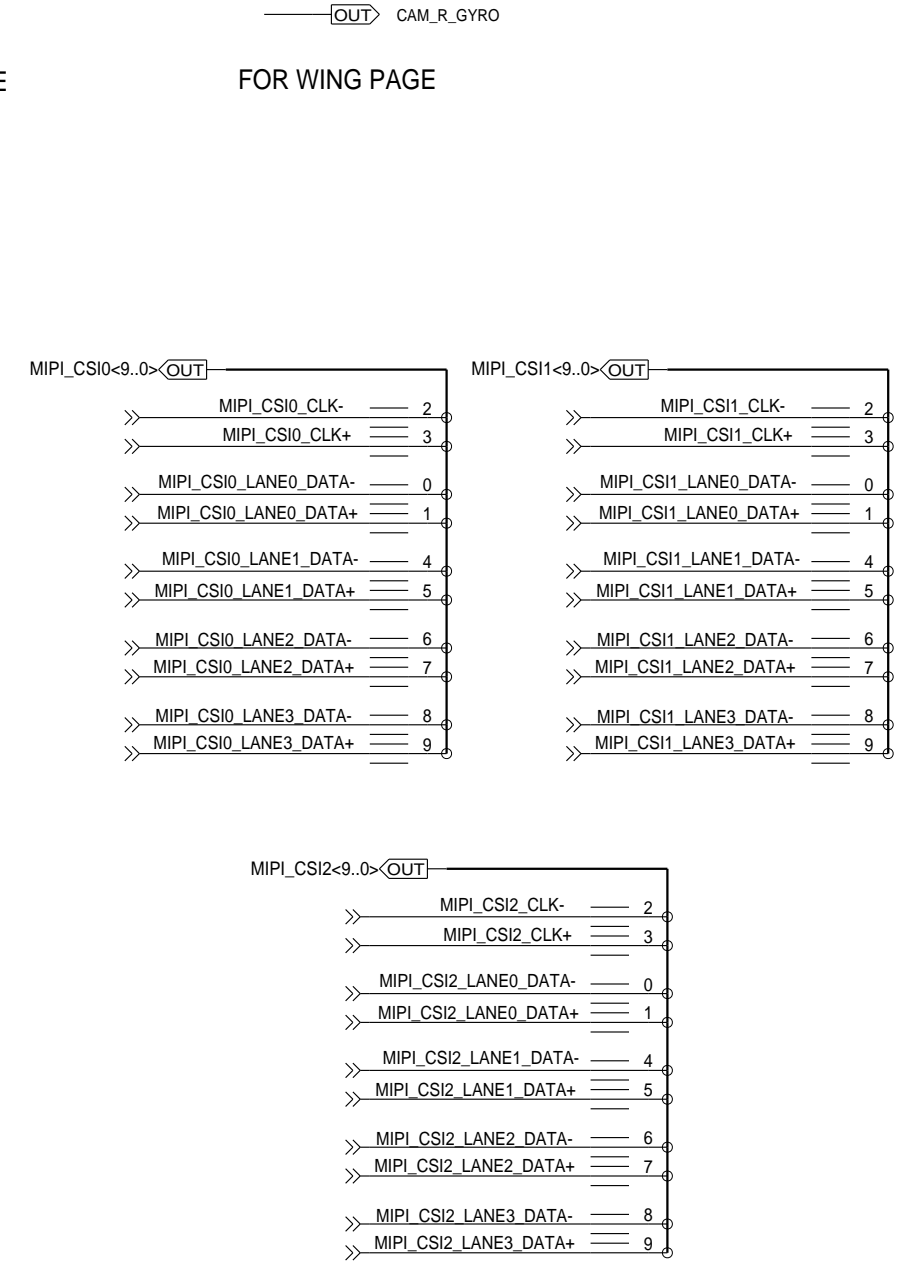

### APPROVALS

ENGINEER: NATE CONNELL

LAST MODIFIED BY: NATE CONNELL  
Thu Jun 05 15:25:54 2014

MOTOROLA CONFIDENTIAL RESTRICTED

THE DRAWING ON THIS PRINT AND INFORMATION  
THEREWITH ARE PROPRIETARY TO MOTOROLA AND  
SHALL NOT BE USED OR DISCUSSED IN WHOLE  
OR IN PART WITHOUT MOTOROLA'S CONSENT.  
© COPYRIGHT, MOTOROLA. THIS DOES  
NOT IMPLY PUBLICATION



BLOCK TITLE:

imagers

PROJECT NAME

B 84016326001\_a.cpm

REV

01

CAD FILE NAME:

PAGE 21 OF 77

# CAM: FRONT

REF 5600-5699

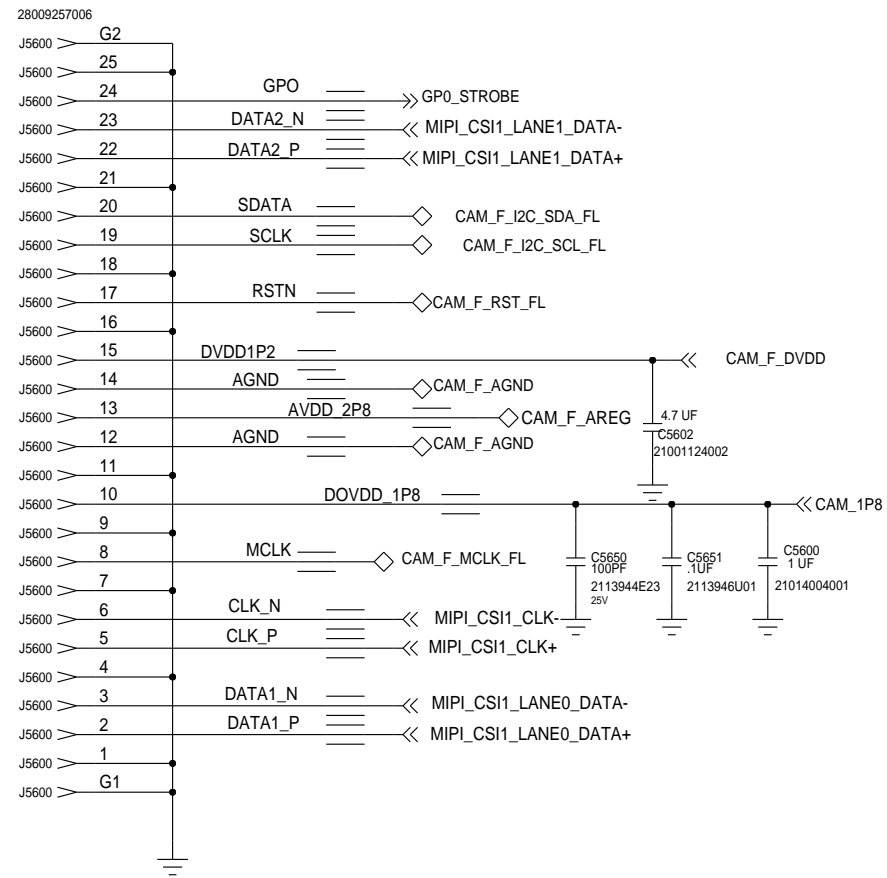

## POWER

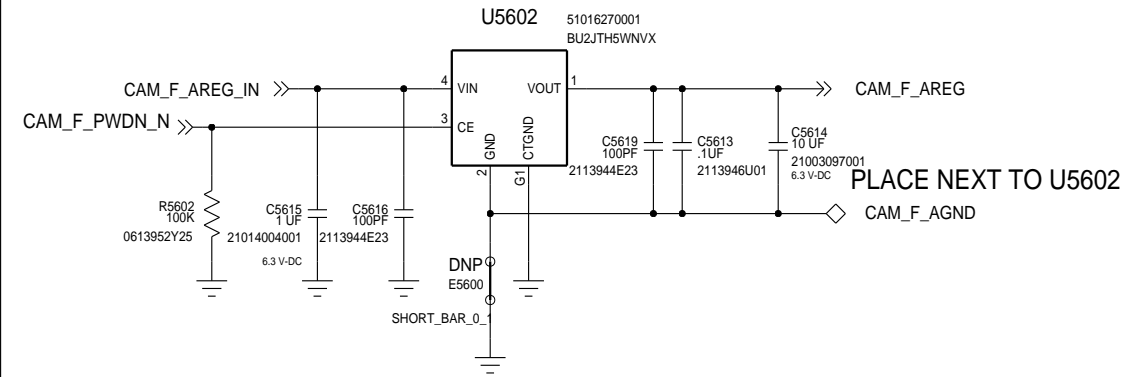

## EMI/ESD FILTER

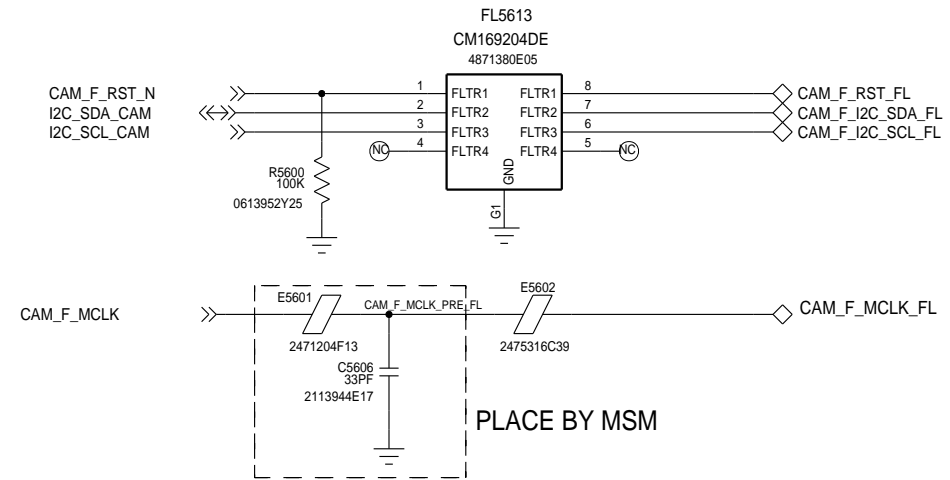

MOTOROLA MOBILITY CONFIDENTIAL RESTRICTED-MDB TRACKED TRACKEDANDBLOCKED

APPROVALS		<b>MOTOROLA</b> MOBILE DEVICES	
ENGINEER: JOHN KRAMER		BLOCK TITLE:	
LAST MODIFIED BY: UID ELRAN Mon Jul 21 14:58:46 2014		<b>imagers</b>	
MOTOROLA CONFIDENTIAL RESTRICTED <small>THE DRAWING ON THIS PRINT AND INFORMATION THEREWITH ARE PROPRIETARY TO MOTOROLA AND SHALL NOT BE USED OR DISCUSSED IN WHOLE OR IN PART WITHOUT MOTOROLA'S CONSENT. © COPYRIGHT, MOTOROLA. THIS DOES NOT IMPLY PUBLICATION</small>		PROJECT NAME	REV
		B 84016326001_a.cpm	01
CAD FILE NAME:		PAGE 22 OF 77	

# CAM: REAR

REF:5500-5599

## LED FLASH DRIVER - LM3646

REF:5750-5799

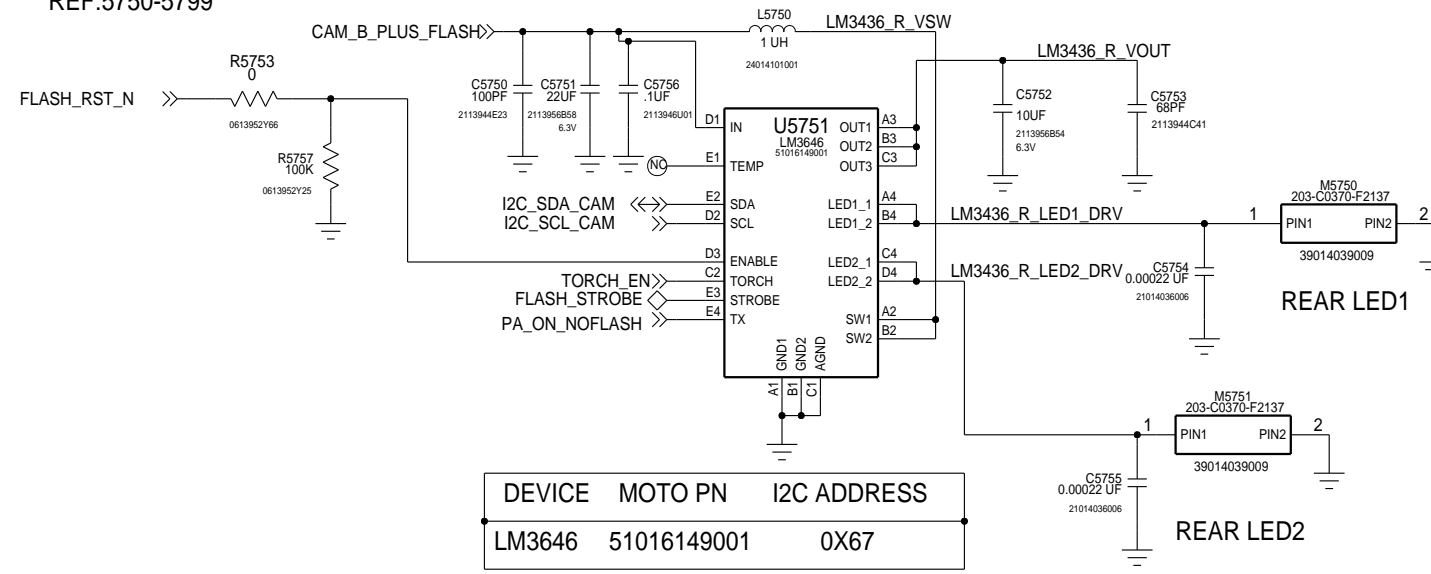

## IMAGER FLEX CONNECTOR

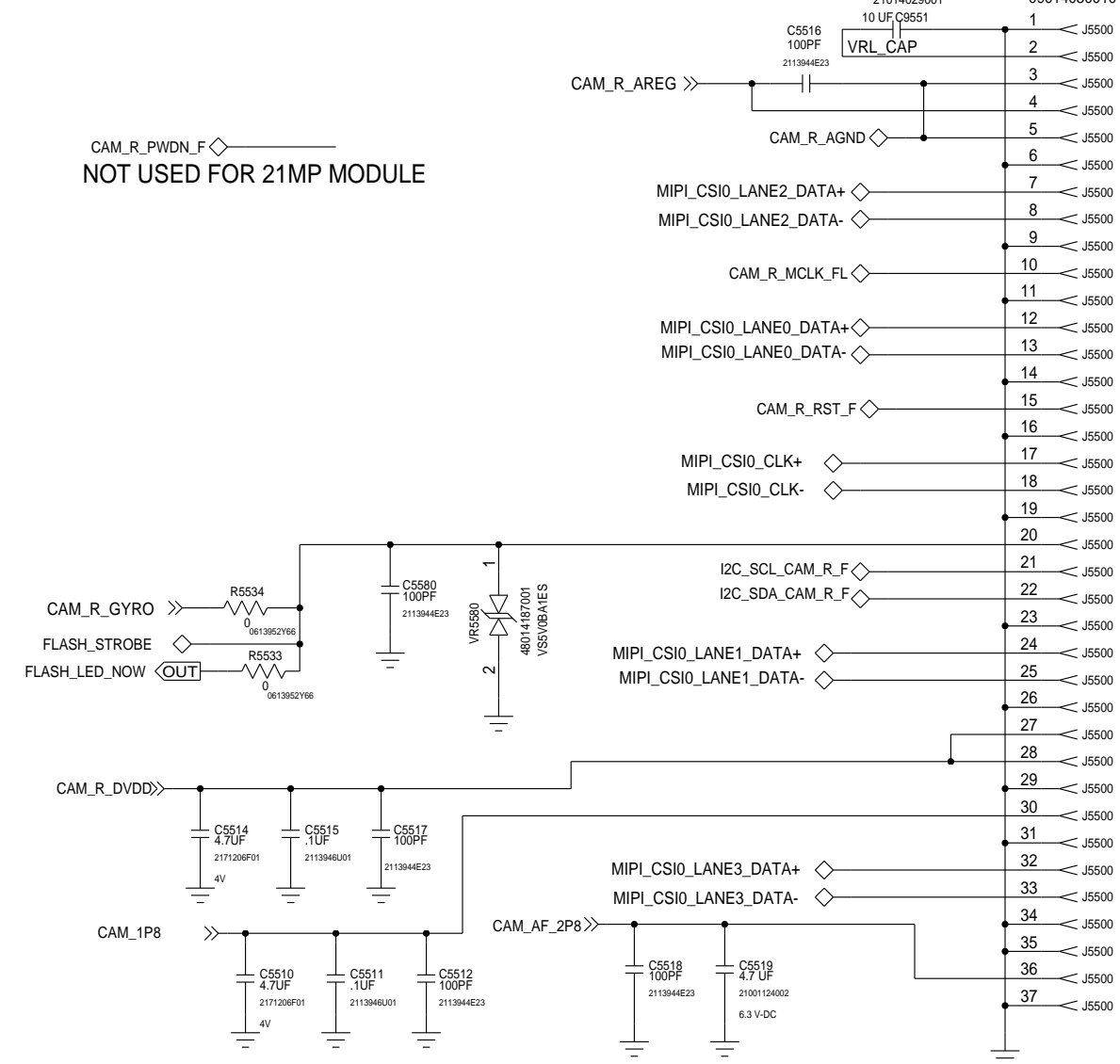

## EMI/ESD FILTER

CAM\_R\_PWDN NOT USED

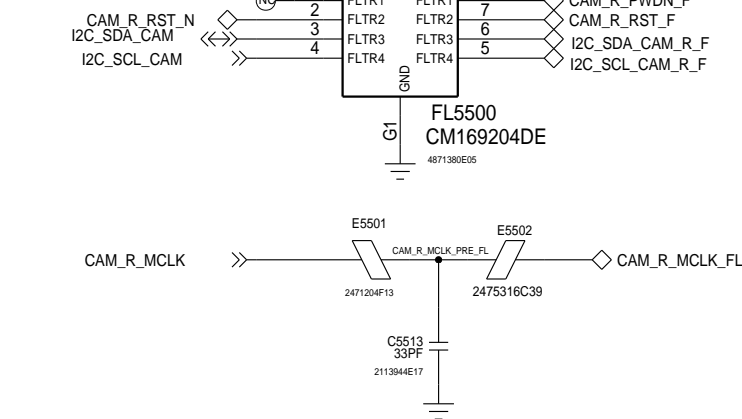

## ANALOG REGULATOR

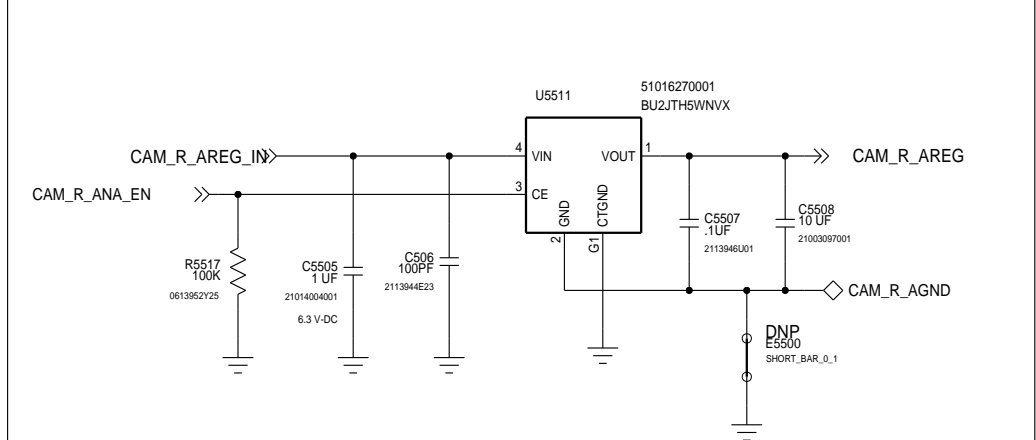

APPROVALS		<b>MOTOROLA</b> MOBILE DEVICES	
ENGINEER: MOTOROLA		BLOCK TITLE: <b>imagers</b>	
LAST MODIFIED BY: MOTOROLA Tue Aug 12 11:16:25 2014		PROJECT NAME 84016326001_a.cpm	
MOTOROLA CONFIDENTIAL RESTRICTED <small>THE DRAWING ON THIS PRINT AND INFORMATION THEREWITH ARE PROPRIETARY TO MOTOROLA AND SHALL NOT BE USED OR DISCUSSED IN WHOLE OR IN PART WITHOUT MOTOROLA'S CONSENT. © COPYRIGHT, MOTOROLA. THIS DOES NOT IMPLY PUBLICATION</small>		CAD FILE NAME:	REV 01
		PAGE 23 OF 77	

# DISP: PORTS

REF 5000-5499

## SUPPLIES

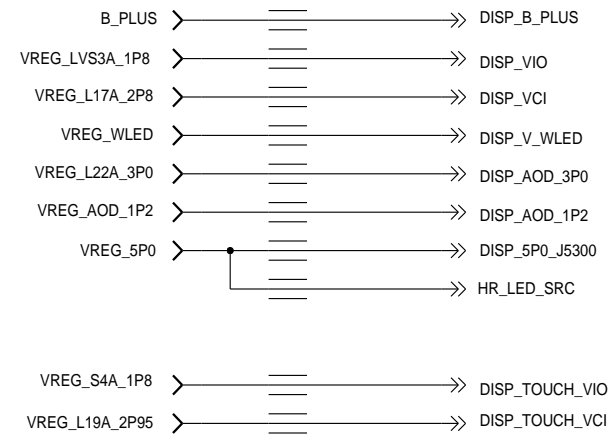

## INPUTS

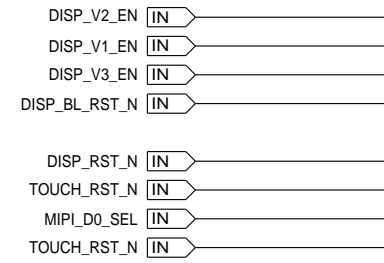

## OUTPUTS

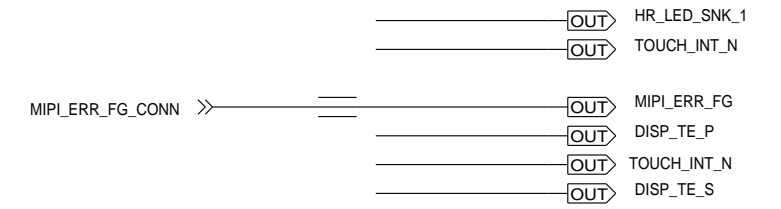

## INTERFACES

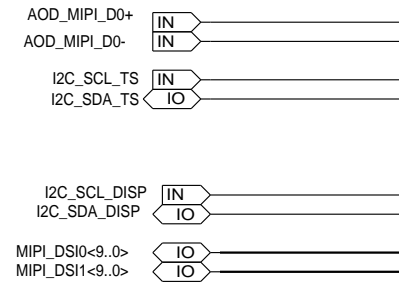

### APPROVALS

ENGINEER: NATE CONNELL

LAST MODIFIED BY: NATE CONNELL  
Thu Jun 05 15:25:51 2014

MOTOROLA CONFIDENTIAL RESTRICTED

THE DRAWING ON THIS PRINT AND INFORMATION  
THEREWITH ARE PROPRIETARY TO MOTOROLA AND  
SHALL NOT BE USED OR DISCUSSED IN WHOLE  
OR IN PART WITHOUT MOTOROLA'S CONSENT.  
© COPYRIGHT, MOTOROLA. THIS DOES  
NOT IMPLY PUBLICATION



BLOCK TITLE:

display

B	PROJECT NAME	REV
	84016326001_a.cpm	01

CAD FILE NAME:



# DISP: CONNECTOR

REF 5300-5349

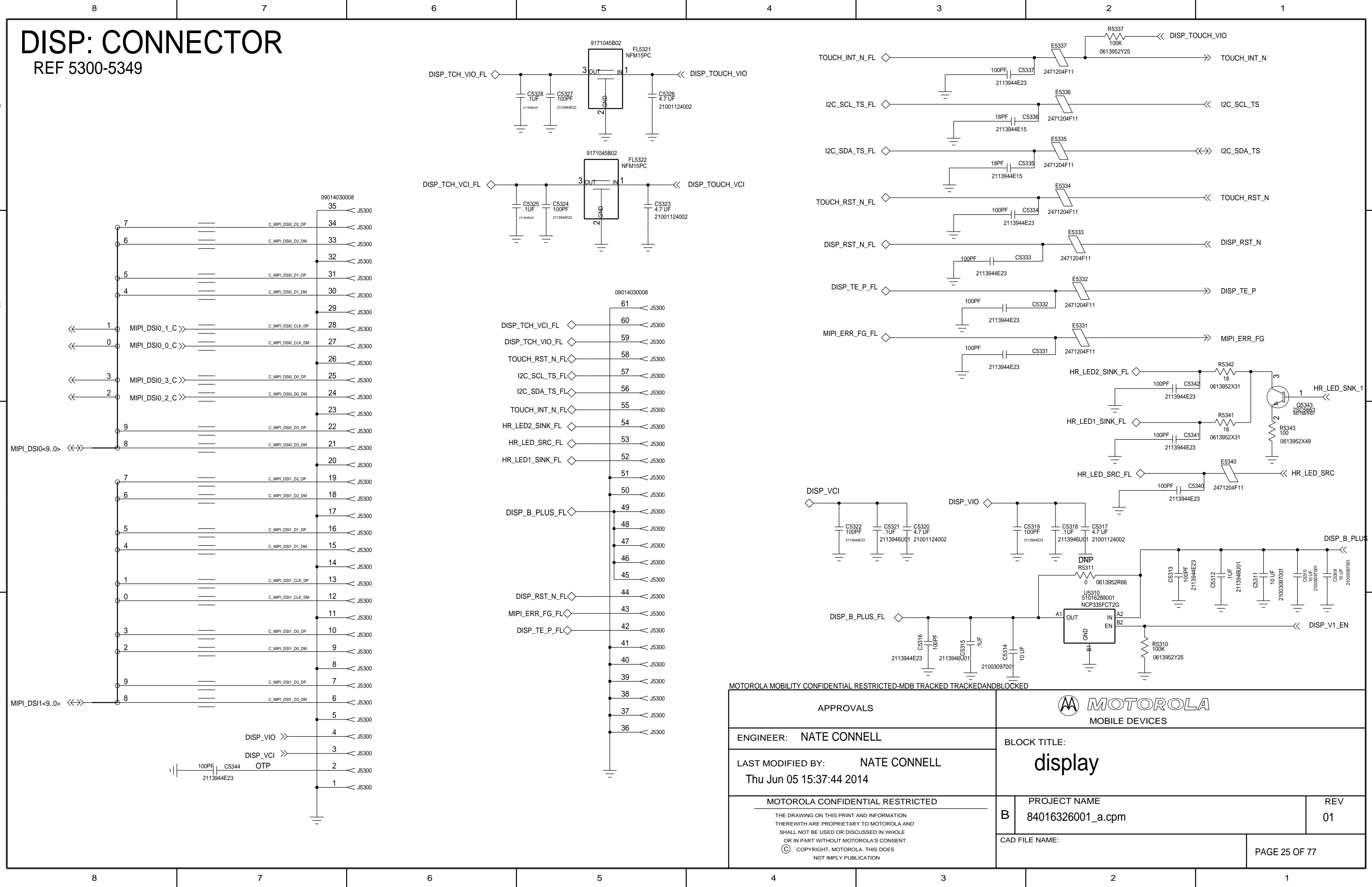

MOTOROLA MOBILITY CONFIDENTIAL RESTRICTED-MDB TRACKED TRACKEDANDBLOCKED

APPROVALS		 <b>MOTOROLA</b> MOBILE DEVICES	
ENGINEER: NATE CONNELL			
LAST MODIFIED BY: NATE CONNELL Thu Jun 05 15:37:44 2014		<b>display</b>	
MOTOROLA CONFIDENTIAL RESTRICTED THE DRAWING ON THIS PRINT AND INFORMATION THEREWITH ARE PROPRIETARY TO MOTOROLA AND SHALL NOT BE USED OR DISCUSSED IN WHOLE OR IN PART WITHOUT MOTOROLA'S CONSENT. © COPYRIGHT, MOTOROLA. THIS DOES NOT IMPLY PUBLICATION		PROJECT NAME	REV
		B 84016326001_a.cpm	01
CAD FILE NAME:		PAGE 25 OF 77	

# DISP: AOD

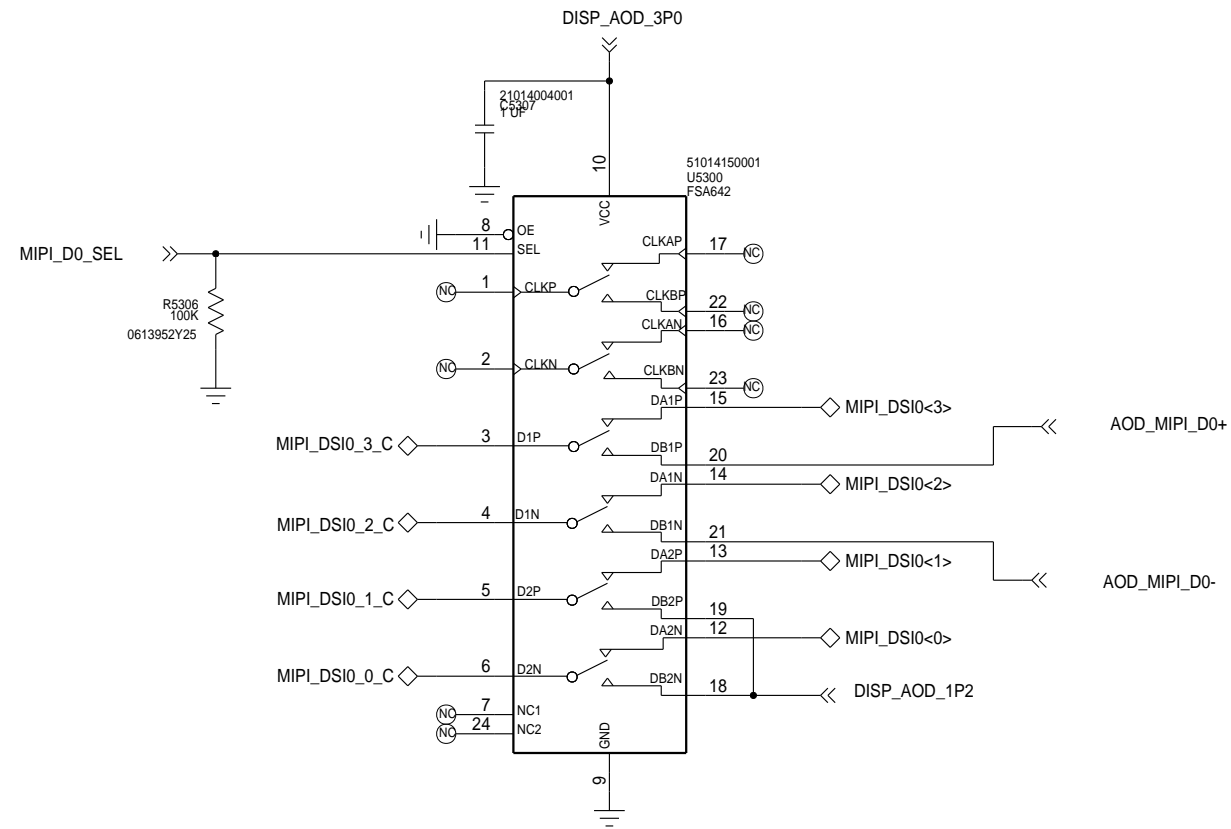

APPROVALS		<b>MOTOROLA</b> MOBILE DEVICES	
ENGINEER: MOTOROLA		BLOCK TITLE:	
LAST MODIFIED BY: MOTOROLA Thu Jun 05 15:25:53 2014		<b>display</b>	
MOTOROLA CONFIDENTIAL RESTRICTED <small>THE DRAWING ON THIS PRINT AND INFORMATION THEREWITH ARE PROPRIETARY TO MOTOROLA AND SHALL NOT BE USED OR DISCUSSED IN WHOLE OR IN PART WITHOUT MOTOROLA'S CONSENT. © COPYRIGHT, MOTOROLA. THIS DOES NOT IMPLY PUBLICATION</small>		PROJECT NAME	REV
		B 84016326001_a.cpm	01
CAD FILE NAME:		PAGE 26 OF 77	

# AFE: PORTS

REF 4500-4999

## SUPPLIES

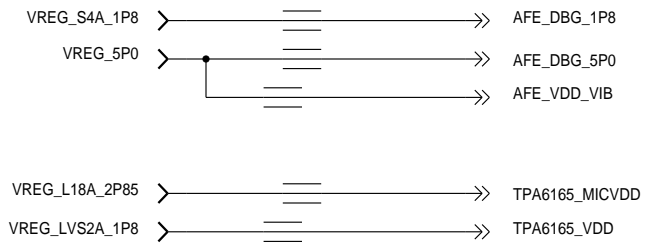

## INPUTS

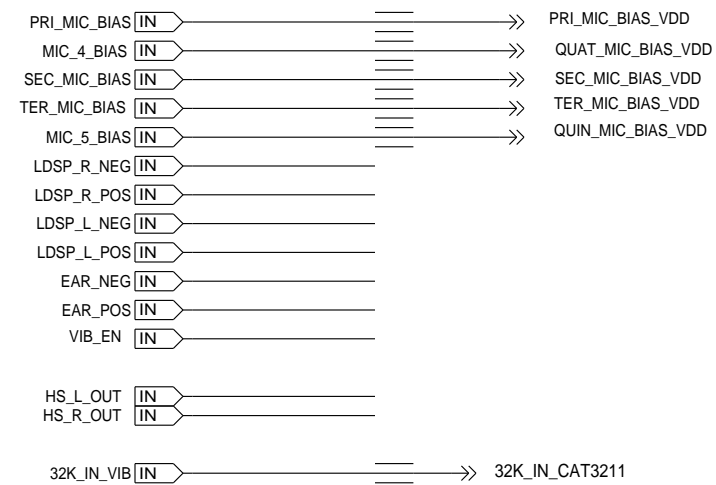

## OUTPUTS

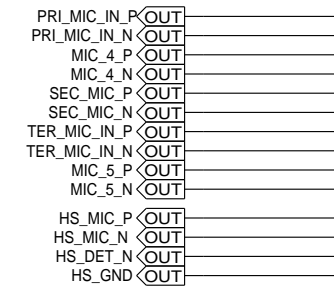

## INTERFACES

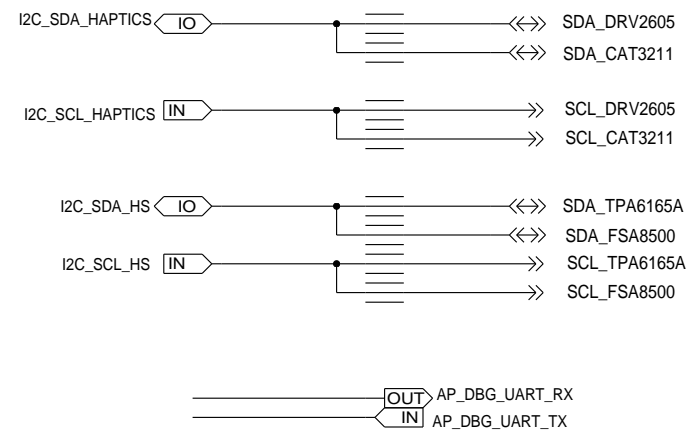

### APPROVALS

ENGINEER: NATE CONNELL

LAST MODIFIED BY: NATE CONNELL  
 Thu Jun 05 15:25:47 2014

MOTOROLA CONFIDENTIAL RESTRICTED

THE DRAWING ON THIS PRINT AND INFORMATION  
 THEREWITH ARE PROPRIETARY TO MOTOROLA AND  
 SHALL NOT BE USED OR DISCUSSED IN WHOLE  
 OR IN PART WITHOUT MOTOROLA'S CONSENT.  
 © COPYRIGHT, MOTOROLA. THIS DOES  
 NOT IMPLY PUBLICATION



BLOCK TITLE:

audio\_fe

PROJECT NAME  
 B 84016326001\_a.cpm

REV  
 01

CAD FILE NAME:

PAGE 27 OF 77

# AFE: MICS

REF: 4500-4599

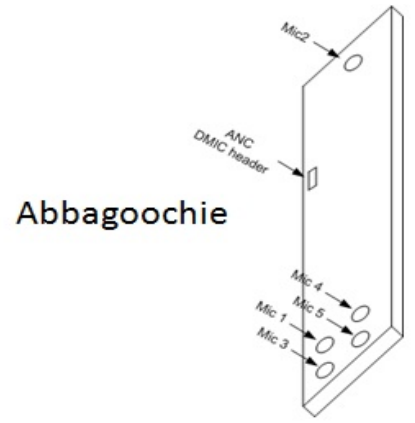
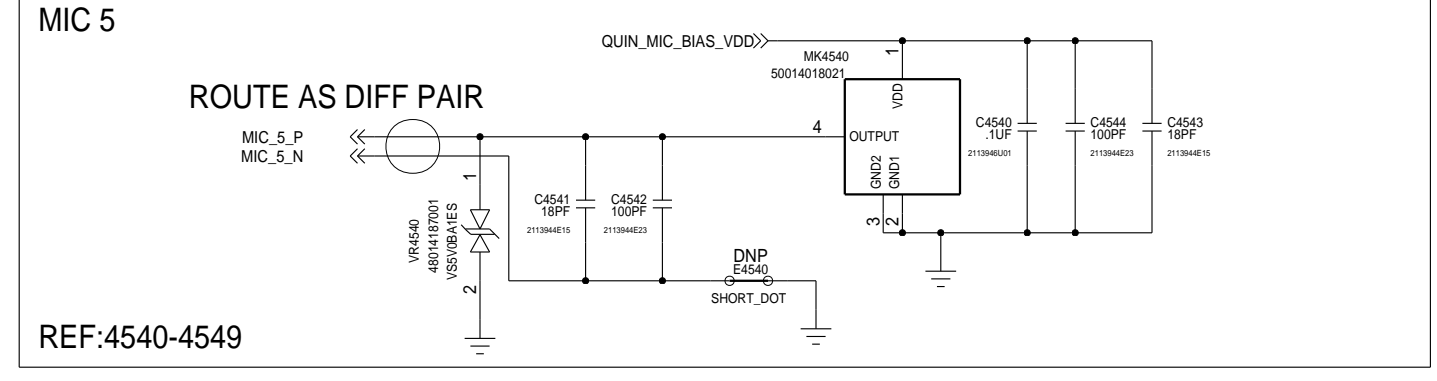
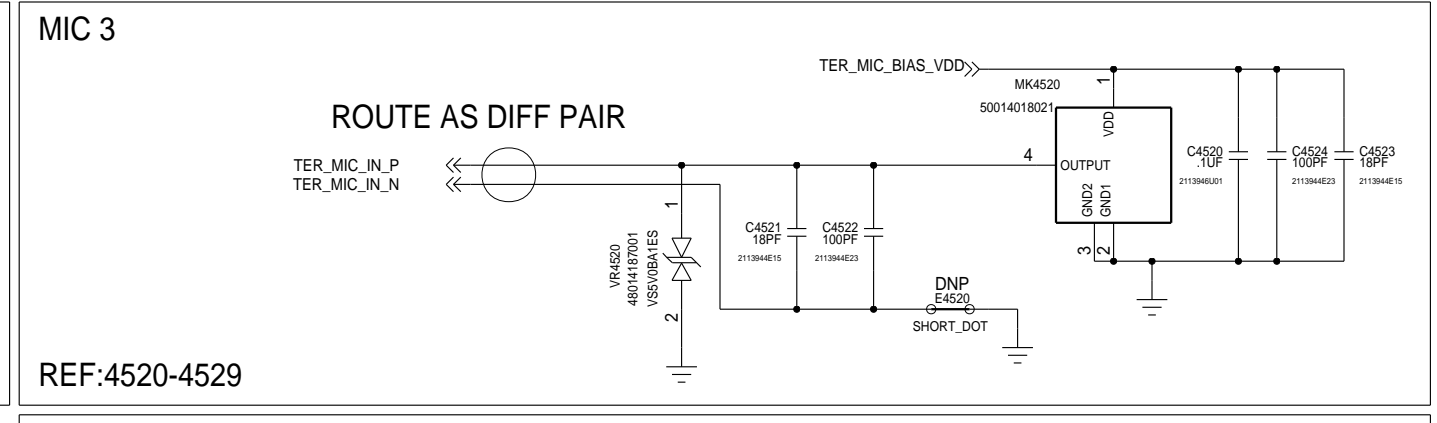
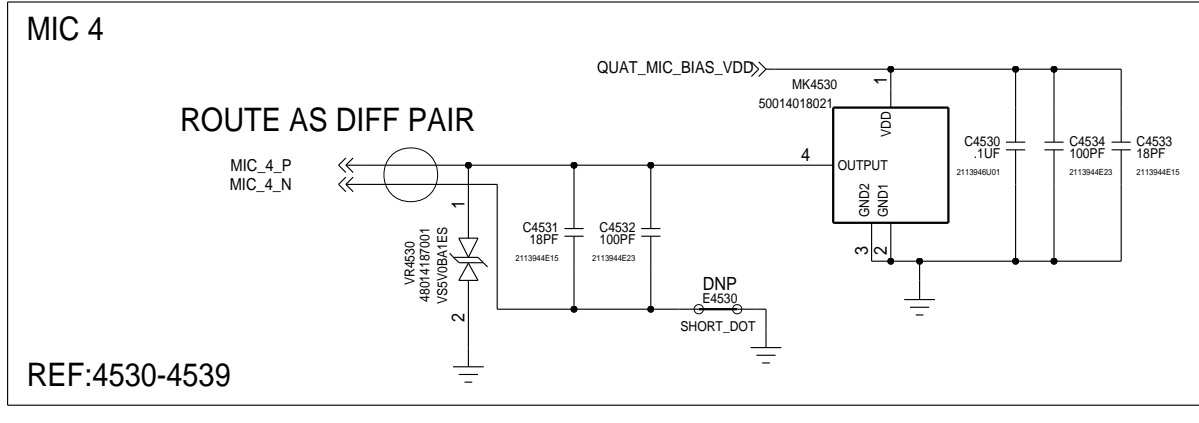
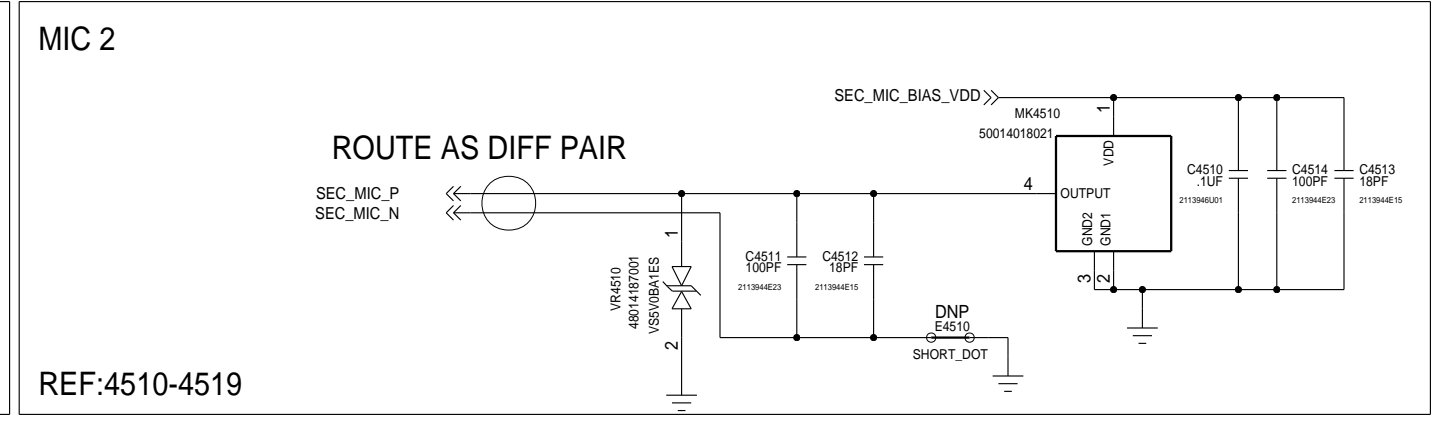
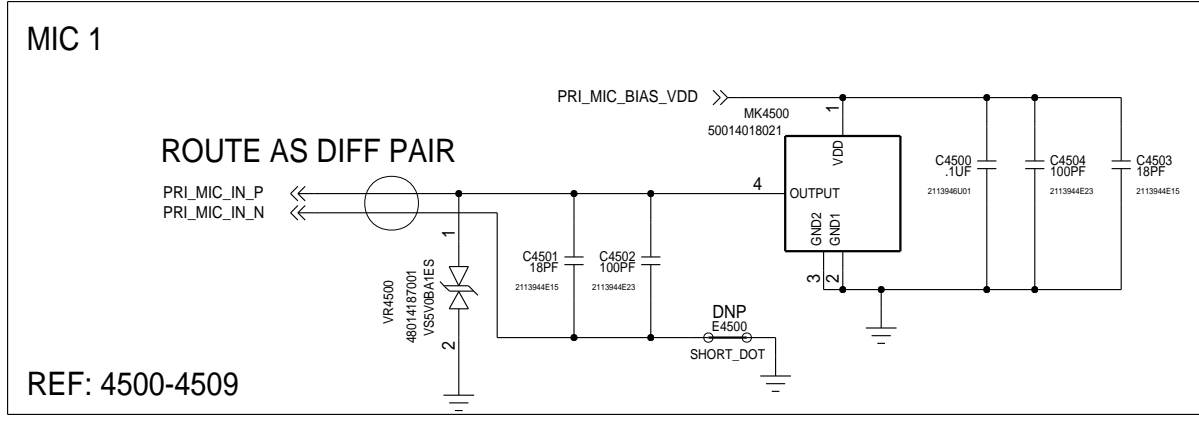

	Voice	AoV	Camcorder	Voice with ANC
Mic 1	X	X	X	X
Mic 2	X	X	X	X
Mic 3	X	X	X	X
Mic 4		X	X	
Mic 5		X	X	
ANC Mic				X

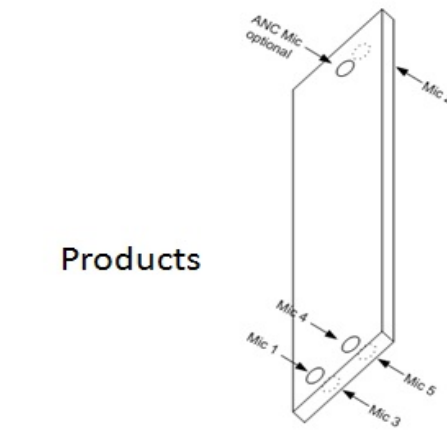

	Voice	AoV	Camcorder	Voice with ANC
Mic 1	X	X	X	
Mic 2	X	X	X	
Mic 3	X	X	X	
Mic 4		X	X	
Mic 5		X	X	
ANC Mic optional				

APPROVALS		<b>MOTOROLA</b> MOBILE DEVICES	
ENGINEER: MOTOROLA		BLOCK TITLE:	
LAST MODIFIED BY: MOTOROLA Tue Jun 17 17:05:18 2014		<b>audio_fe</b>	
MOTOROLA CONFIDENTIAL RESTRICTED <small>THE DRAWING ON THIS PRINT AND INFORMATION THEREWITH ARE PROPRIETARY TO MOTOROLA AND SHALL NOT BE USED OR DISCUSSED IN WHOLE OR IN PART WITHOUT MOTOROLA'S CONSENT.          © COPYRIGHT, MOTOROLA. THIS DOES NOT IMPLY PUBLICATION</small>		PROJECT NAME	REV
		B 84016326001_a.cpm	01
CAD FILE NAME:		PAGE 28 OF 77	

# AFE: SPEAKERS

REF: 4600-4699

## LOUDSPEAKER RIGHT (BOTTOM)

REF:4670-4674

## LOUDSPEAKER LEFT (TOP)

REF:4680-4684

## EAR PIECE

REF:4690-4699

## ROTARY VIBRATOR REF DES 4600-4619

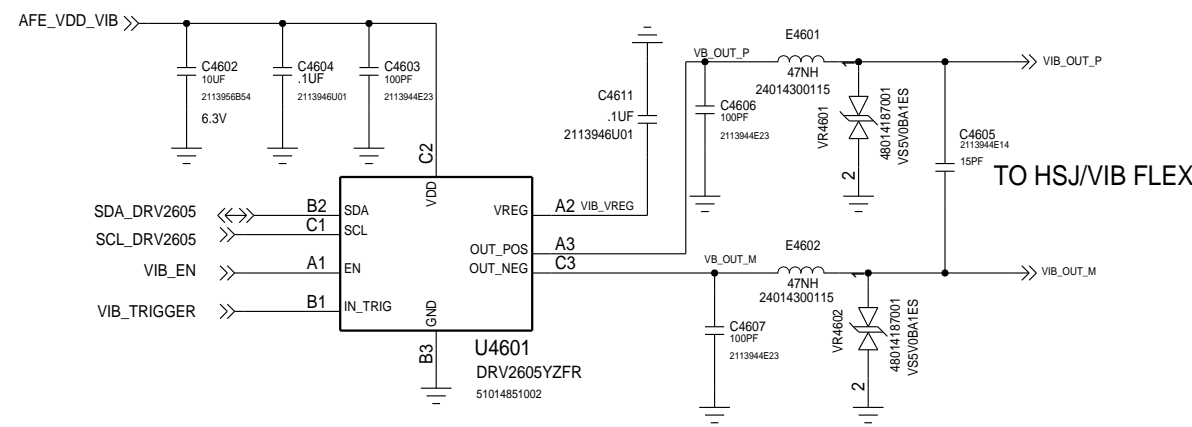

MOTOROLA MOBILITY CONFIDENTIAL RESTRICTED-MDB TRACKED TRACKEDANDBLOCKED

APPROVALS		<b>MOTOROLA</b> MOBILE DEVICES	
ENGINEER: DENNIS BUDNICK		BLOCK TITLE:	
LAST MODIFIED BY: TIM MILLER Wed Aug 06 11:13:45 2014		<b>audio_fe</b>	
MOTOROLA CONFIDENTIAL RESTRICTED <small>THE DRAWING ON THIS PRINT AND INFORMATION THEREWITH ARE PROPRIETARY TO MOTOROLA AND SHALL NOT BE USED OR DISCUSSED IN WHOLE OR IN PART WITHOUT MOTOROLA'S CONSENT. © COPYRIGHT, MOTOROLA. THIS DOES NOT IMPLY PUBLICATION</small>		PROJECT NAME	REV
		B 84016326001_a.cpm	01
CAD FILE NAME:		PAGE 29 OF 77	

# AFE: 3.5MM HEADSET

## UNIVERSAL HEADSET REF:4900-4949

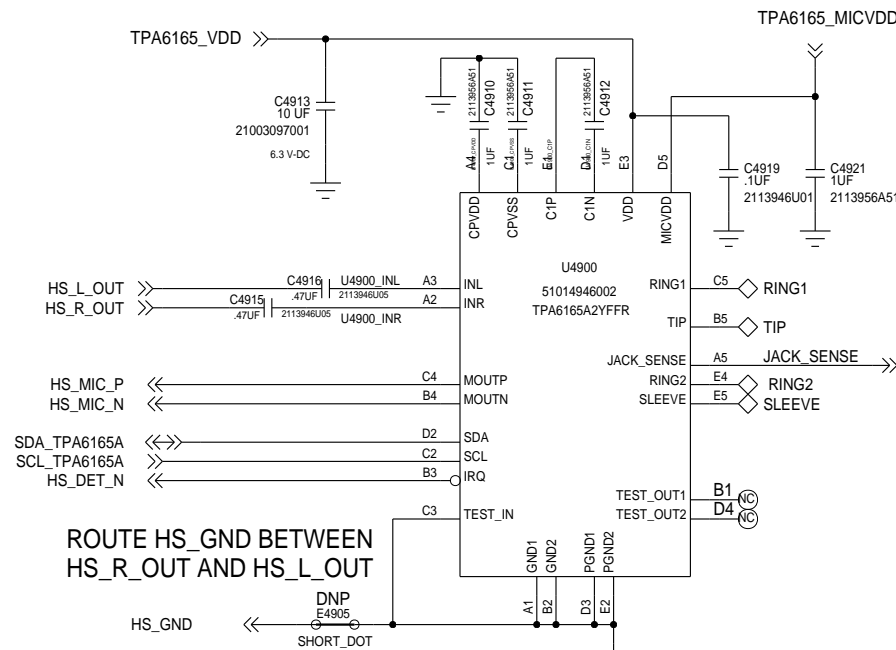

## UART OVER HEADSET REF:4950-4999

(DNI FOR PRODUCTION)

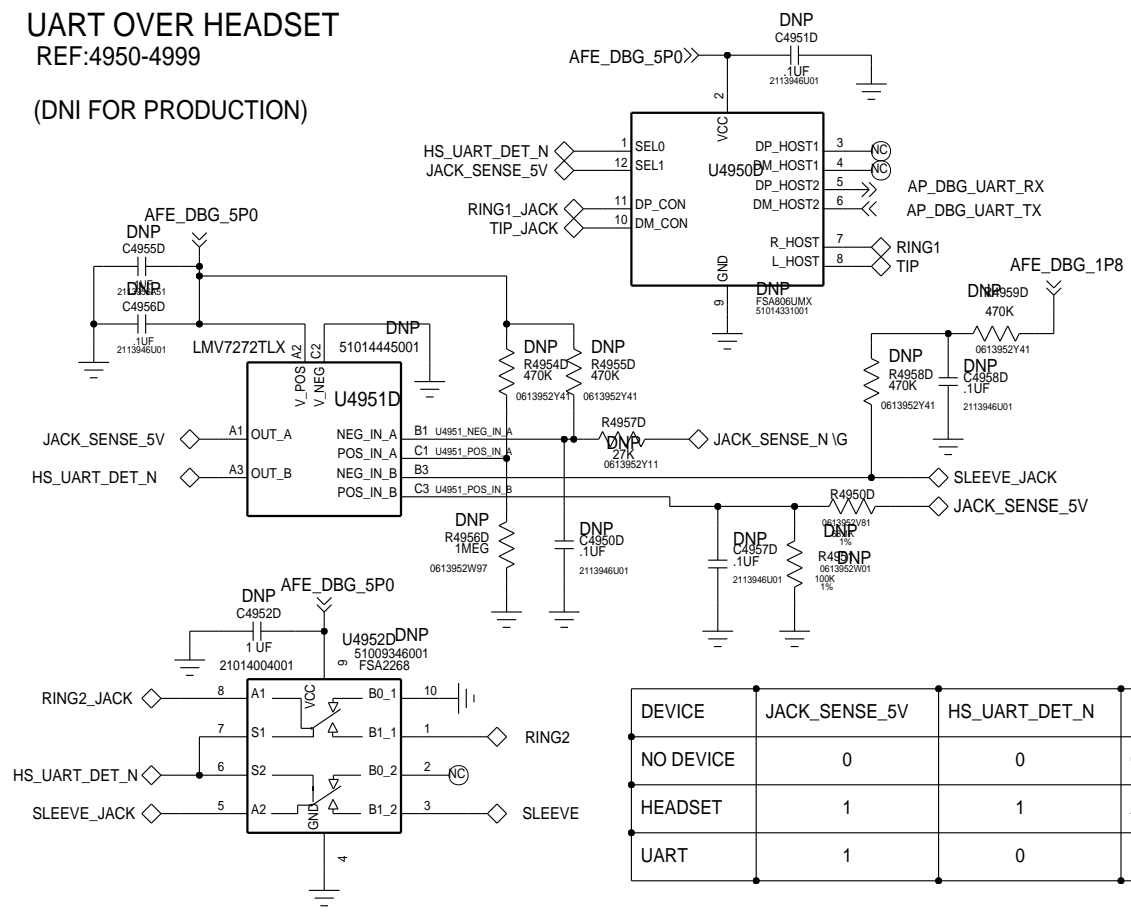

## 3.5MM HSJ REF:4900-4949

ROUTE AS DIFF PAIR

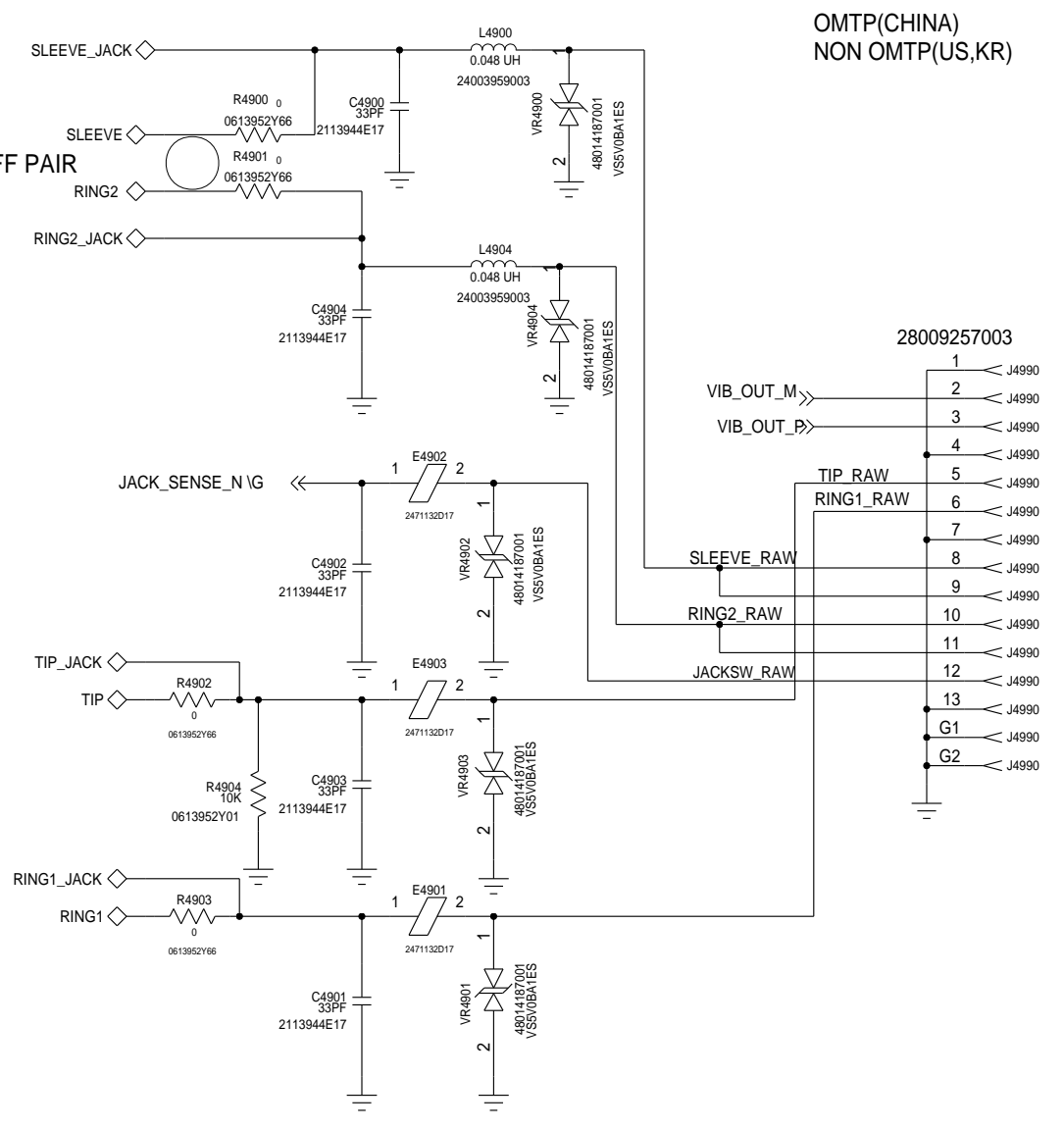

OMTP(CHINA)  
NON OMTP(US,KR)

28009257003

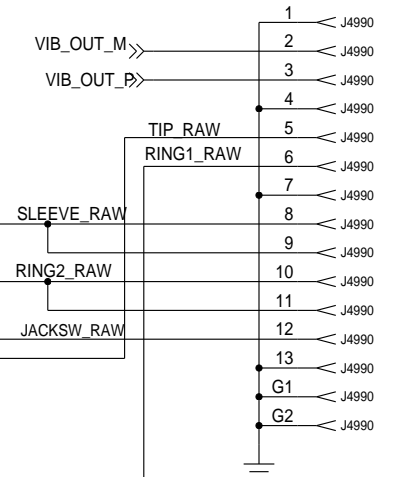

MOTOROLA MOBILITY CONFIDENTIAL RESTRICTED-MDB TRACKED TRACKEDANDBLOCKED

APPROVALS		MOTOROLA MOBILE DEVICES	
ENGINEER: MATT MOTTIER	BLOCK TITLE: <b>audio_fe</b>		
LAST MODIFIED BY: NATE CONNELL Thu Jun 05 15:25:50 2014	PROJECT NAME B 84016326001_a.cpm		REV 01
MOTOROLA CONFIDENTIAL RESTRICTED <small>THE DRAWING ON THIS PRINT AND INFORMATION THEREWITH ARE PROPRIETARY TO MOTOROLA AND SHALL NOT BE USED OR DISCUSSED IN WHOLE OR IN PART WITHOUT MOTOROLA'S CONSENT. © COPYRIGHT, MOTOROLA. THIS DOES NOT IMPLY PUBLICATION</small>		CAD FILE NAME: PAGE 30 OF 77	

# PWR: PORTS

REF 500-799

## SUPPLIES

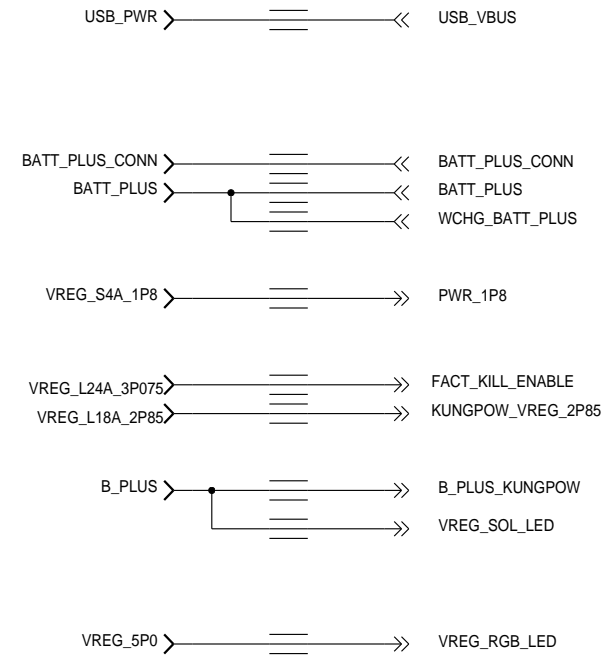

## INPUTS

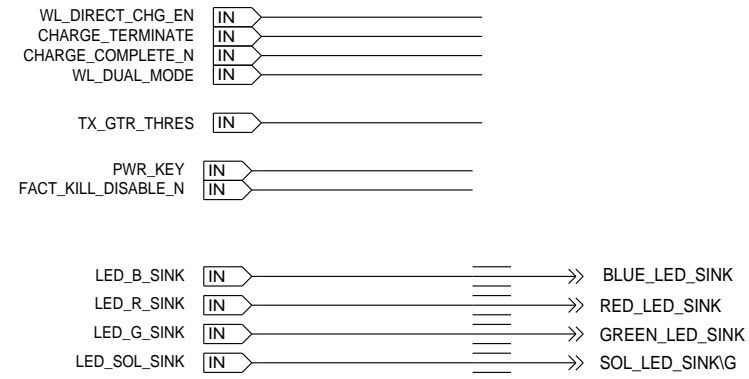

## OUTPUTS

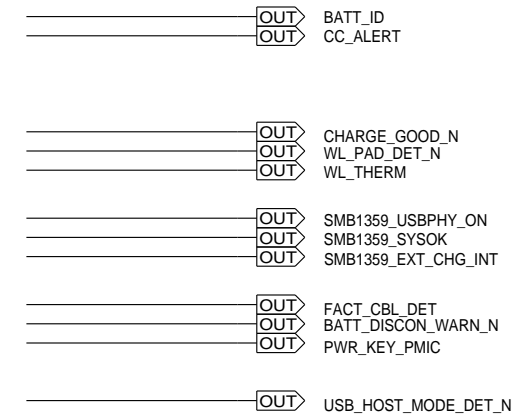

## INTERFACES

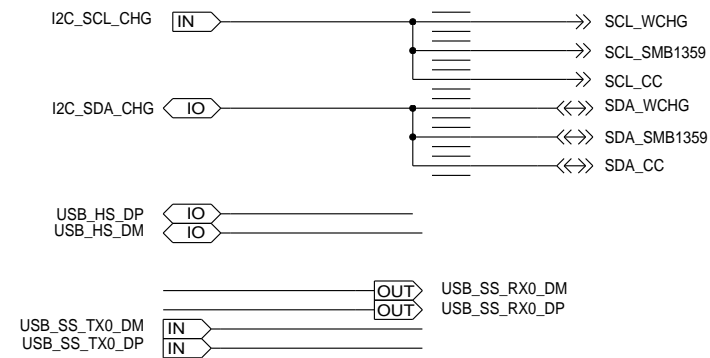

### APPROVALS

ENGINEER: NATE CONNELL

LAST MODIFIED BY: NATE CONNELL  
Thu Jun 05 15:25:43 2014

MOTOROLA CONFIDENTIAL RESTRICTED

THE DRAWING ON THIS PRINT AND INFORMATION  
THEREWITH ARE PROPRIETARY TO MOTOROLA AND  
SHALL NOT BE USED OR DISCUSSED IN WHOLE  
OR IN PART WITHOUT MOTOROLA'S CONSENT.  
© COPYRIGHT, MOTOROLA. THIS DOES  
NOT IMPLY PUBLICATION



BLOCK TITLE:

**power**

PROJECT NAME  
B 84016326001\_a.cpm

REV  
01

CAD FILE NAME:

PAGE 31 OF 77

# PWR: USB2 / BATT

REF: 500-530

## MICRO USB

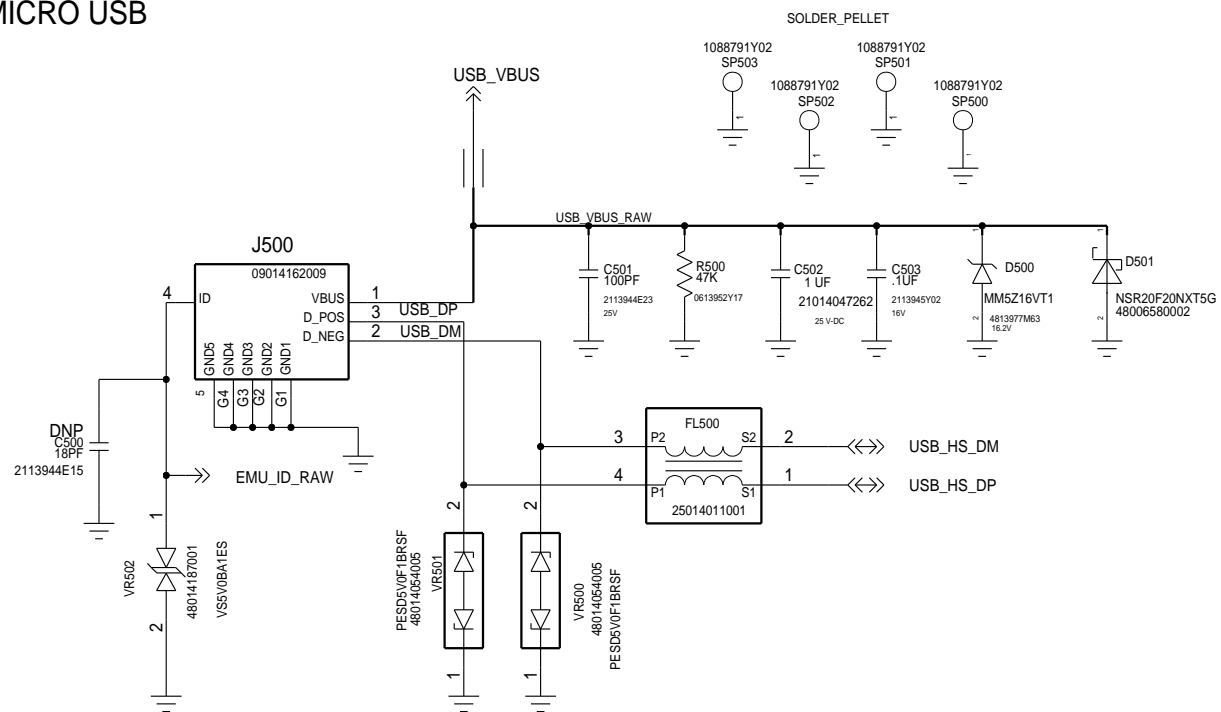

## BATTERY BLOCK

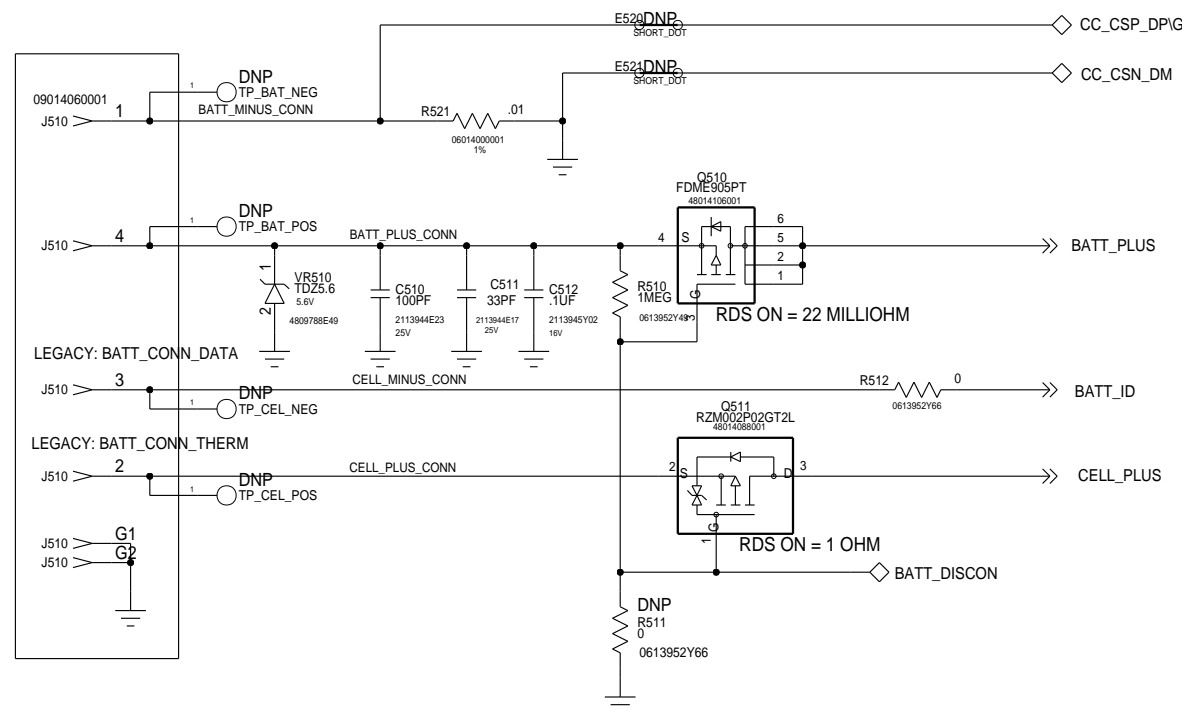

## KUNG POW BATTERY DISCONNECT

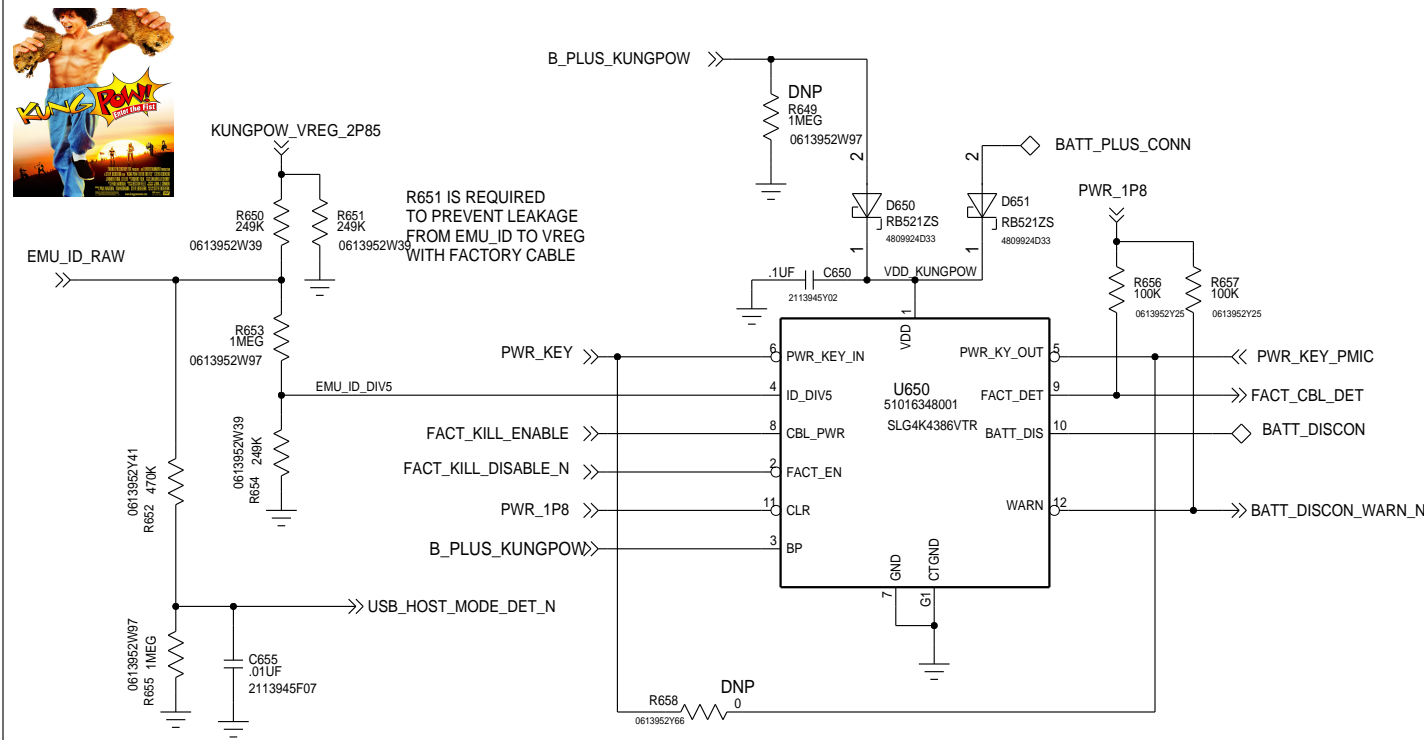

## FUEL GAUGE

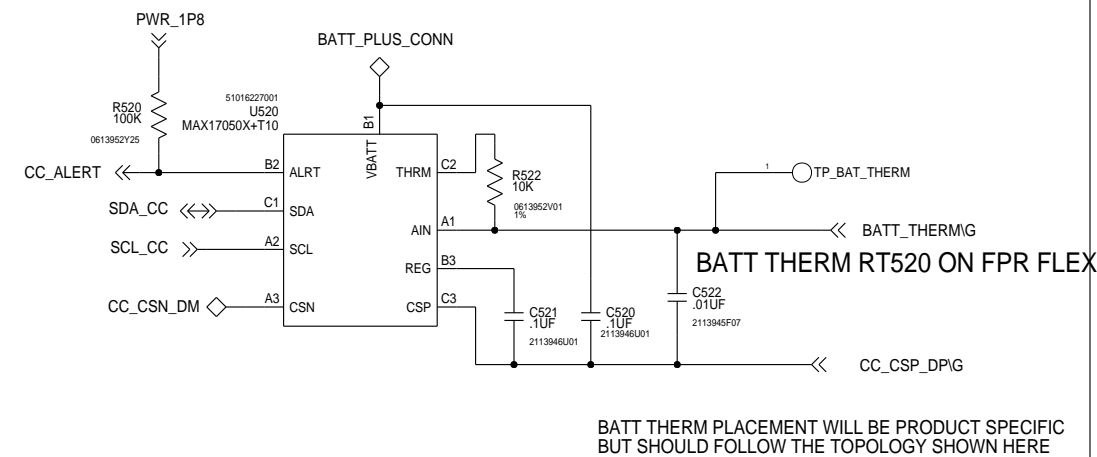

MOTOROLA MOBILITY CONFIDENTIAL RESTRICTED-MDB TRACKED TRACKEDANDBLOCKED

APPROVALS		 MOBILE DEVICES	
ENGINEER: RICH NG		BLOCK TITLE:	
LAST MODIFIED BY: UDI ELRAN Tue Jun 10 18:46:21 2014		<h1>power</h1>	
MOTOROLA CONFIDENTIAL RESTRICTED		PROJECT NAME	REV
THE DRAWING ON THIS PRINT AND INFORMATION THEREWITH ARE PROPRIETARY TO MOTOROLA AND SHALL NOT BE USED OR DISCUSSED IN WHOLE OR IN PART WITHOUT MOTOROLA'S CONSENT. © COPYRIGHT, MOTOROLA. THIS DOES NOT IMPLY PUBLICATION		B 84016326001_a.cpm	01
		CAD FILE NAME:	PAGE 32 OF 77



# PWR: EXT CHG

REF: 540-559

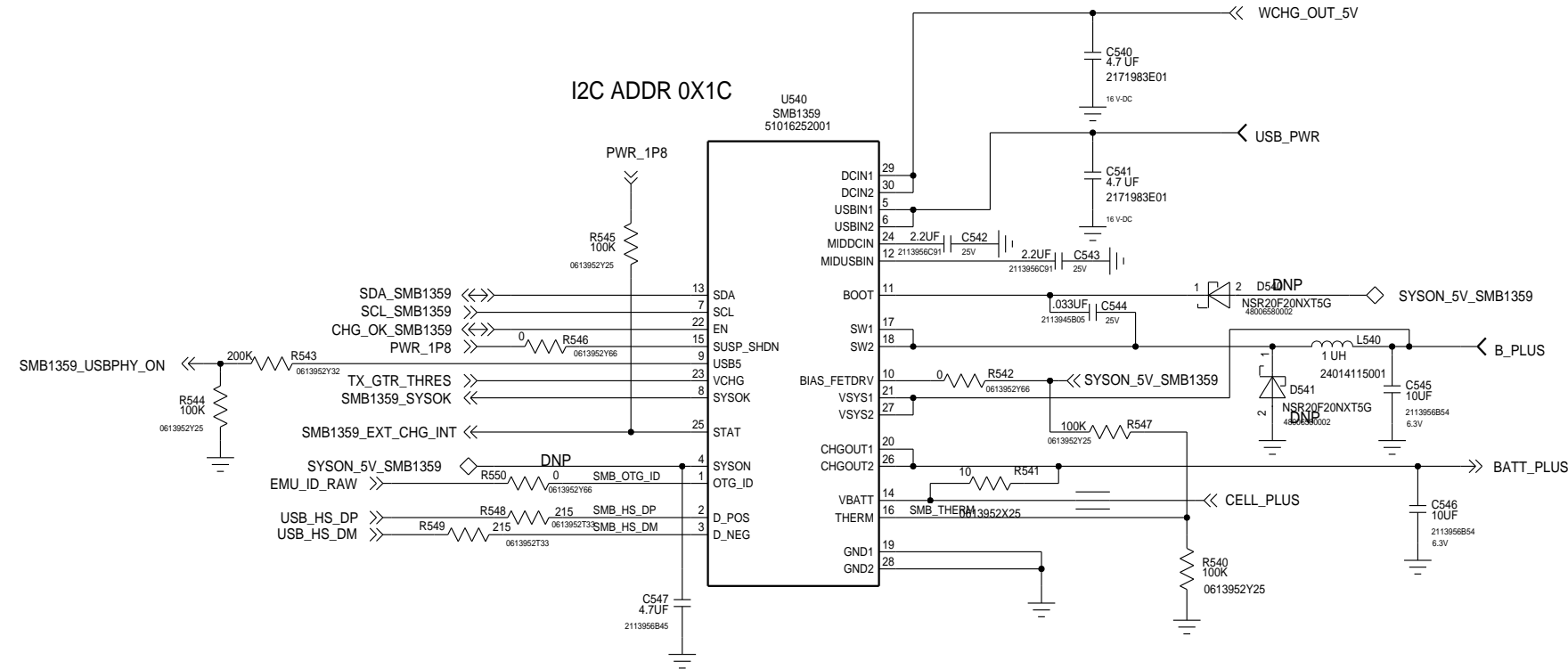

APPROVALS		<b>MOTOROLA</b> MOBILE DEVICES	
ENGINEER:		BLOCK TITLE:	
LAST MODIFIED BY: R. NG Fri Jun 13 15:34:10 2014		<b>power</b>	
MOTOROLA CONFIDENTIAL RESTRICTED <small>THE DRAWING ON THIS PRINT AND INFORMATION THEREWITH ARE PROPRIETARY TO MOTOROLA AND SHALL NOT BE USED OR DISCUSSED IN WHOLE OR IN PART WITHOUT MOTOROLA'S CONSENT.          © COPYRIGHT, MOTOROLA. THIS DOES NOT IMPLY PUBLICATION</small>		PROJECT NAME <b>B 84016326001_a.cpm</b>	REV <b>01</b>
		CAD FILE NAME:	
		PAGE 33 OF 77	

# PWR: LIGHTING

TRI-COLOR LED  
REF: 600-609

SOL LED  
REF: 610-619

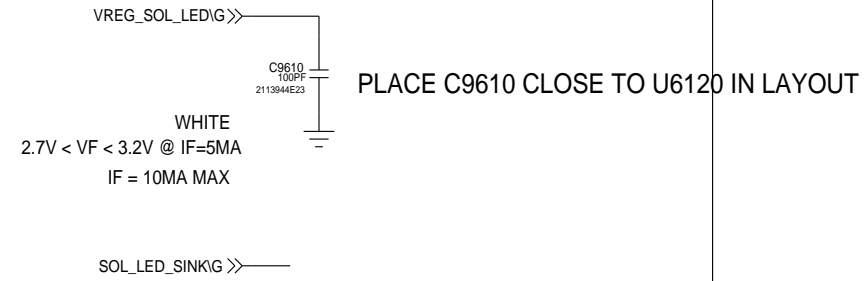

SOL LED D610 MOVED TO PROX/SOL SPACER BRD

MOTOROLA MOBILITY CONFIDENTIAL RESTRICTED-MDB TRACKED TRACKEDANDBLOCKED

APPROVALS		<b>MOTOROLA</b> MOBILE DEVICES	
ENGINEER:		BLOCK TITLE:	
LAST MODIFIED BY: <b>TIM MILLER</b> Thu Jun 05 15:25:45 2014		<b>power</b>	
MOTOROLA CONFIDENTIAL RESTRICTED <small>THE DRAWING ON THIS PRINT AND INFORMATION THEREWITH ARE PROPRIETARY TO MOTOROLA AND SHALL NOT BE USED OR DISCUSSED IN WHOLE OR IN PART WITHOUT MOTOROLA'S CONSENT. © COPYRIGHT, MOTOROLA. THIS DOES NOT IMPLY PUBLICATION</small>		PROJECT NAME <b>B 84016326001_a.cpm</b>	REV <b>01</b>
		CAD FILE NAME:	
		PAGE 34 OF 77	

# PWR: WCHG

REF: 560-599

WCHG\_BATT\_PLUS

CONTROLLED BY APPS PROC

WL\_DIRECT\_CHG\_EN

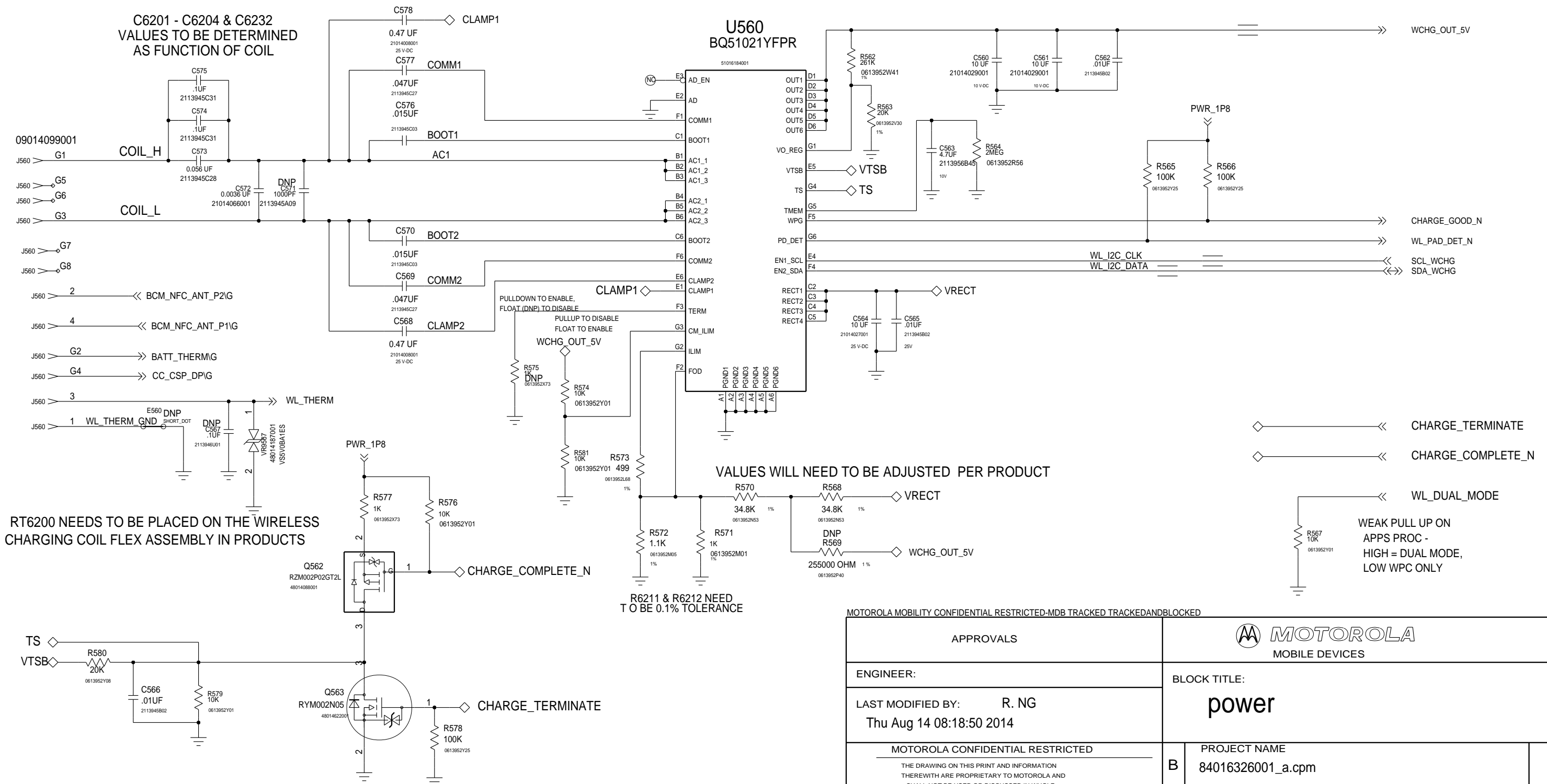

MOTOROLA MOBILITY CONFIDENTIAL RESTRICTED-MDB TRACKED TRACKEDANDBLOCKED

APPROVALS		 <b>MOTOROLA</b> MOBILE DEVICES	
ENGINEER:		BLOCK TITLE:	
LAST MODIFIED BY: R. NG		<b>power</b>	
Thu Aug 14 08:18:50 2014		PROJECT NAME	REV
MOTOROLA CONFIDENTIAL RESTRICTED		B 84016326001_a.cpm	01
THE DRAWING ON THIS PRINT AND INFORMATION THEREWITH ARE PROPRIETARY TO MOTOROLA AND SHALL NOT BE USED OR DISCUSSED IN WHOLE OR IN PART WITHOUT MOTOROLA'S CONSENT.		PAGE 35 OF 77	
© COPYRIGHT, MOTOROLA. THIS DOES NOT IMPLY PUBLICATION			

# CONN: POWER

REF 4490-4499

## SUPPLIES

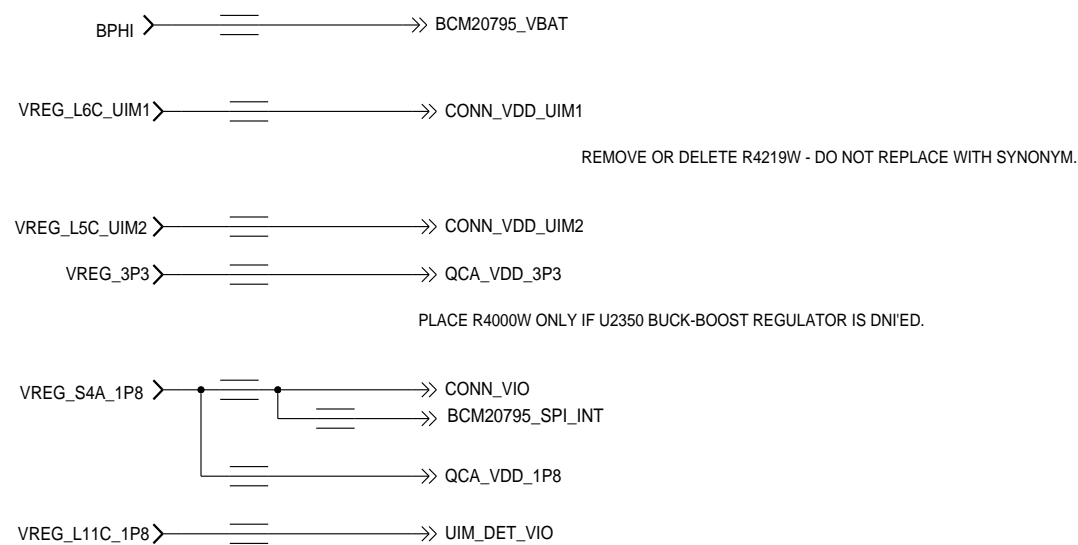

APPROVALS		<b>MOTOROLA</b> MOBILE DEVICES	
ENGINEER: FROEHLING		BLOCK TITLE:	
LAST MODIFIED BY: FROEHLING Thu Jun 05 15:25:38 2014		<b>connectivity</b>	
MOTOROLA CONFIDENTIAL RESTRICTED <small>THE DRAWING ON THIS PRINT AND INFORMATION THEREWITH ARE PROPRIETARY TO MOTOROLA AND SHALL NOT BE USED OR DISCUSSED IN WHOLE OR IN PART WITHOUT MOTOROLA'S CONSENT. © COPYRIGHT, MOTOROLA. THIS DOES NOT IMPLY PUBLICATION</small>		PROJECT NAME <b>B</b> 84016326001_a.cpm	REV 01
		CAD FILE NAME:	PAGE 36 OF 77

# CONN: PORTS

REF 4000-4499

## BT/WLAN SYSTEM

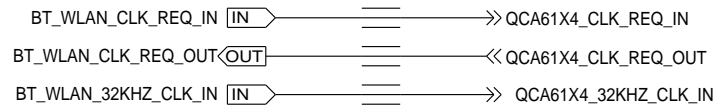

## WLAN

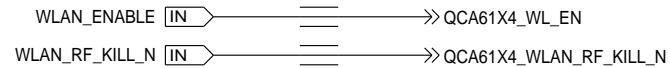

## PCIE

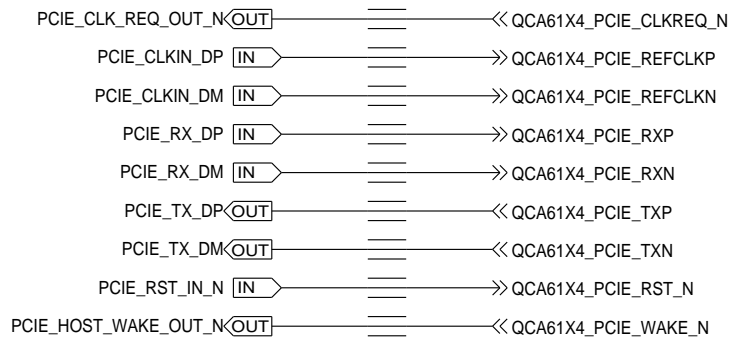

## BT CONTROLS AND INTERFACES

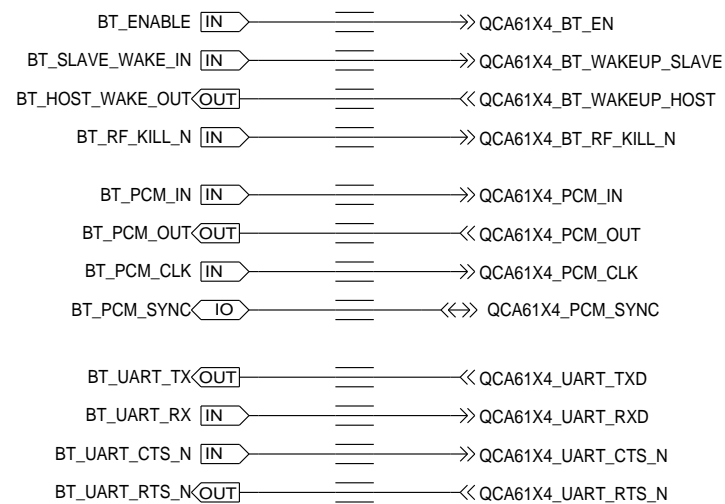

## CELLULAR MODEM/GPS COEXISTENCE

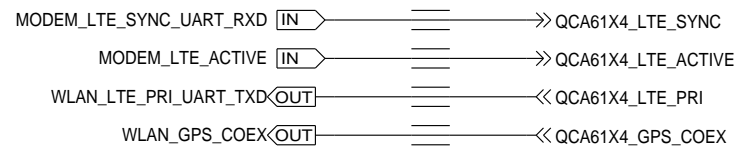

## NFC

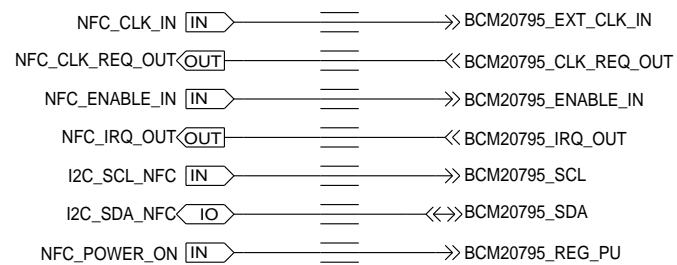

## UIM1

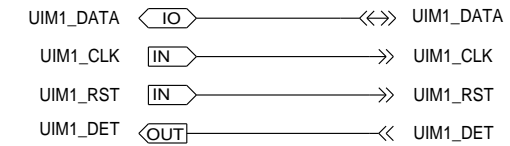

## UIM2

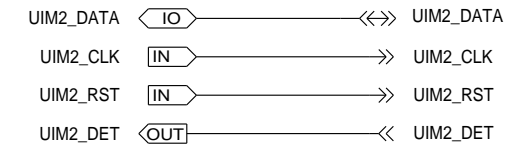

## ANTENNA

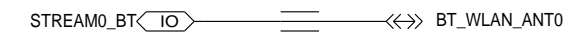

## MISCELLANEOUS

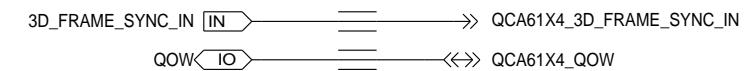

### APPROVALS

ENGINEER: FROEHLING

LAST MODIFIED BY: FROEHLING  
 Tue Dec 17 14:31:06 2013

MOTOROLA CONFIDENTIAL RESTRICTED

THE DRAWING ON THIS PRINT AND INFORMATION  
 THEREWITH ARE PROPRIETARY TO MOTOROLA AND  
 SHALL NOT BE USED OR DISCUSSED IN WHOLE  
 OR IN PART WITHOUT MOTOROLA'S CONSENT.  
 © COPYRIGHT, MOTOROLA. THIS DOES  
 NOT IMPLY PUBLICATION



BLOCK TITLE:

connectivity

PROJECT NAME

B 84016326001\_a.cpm

REV

01

CAD FILE NAME:

PAGE 37 OF 77

# CONN: QCA6164 HOST I/F

REF: 4000-4099

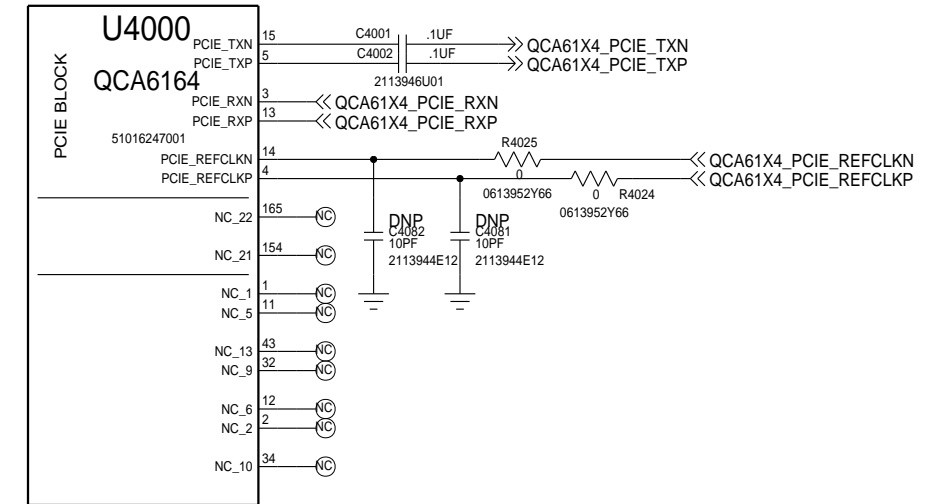
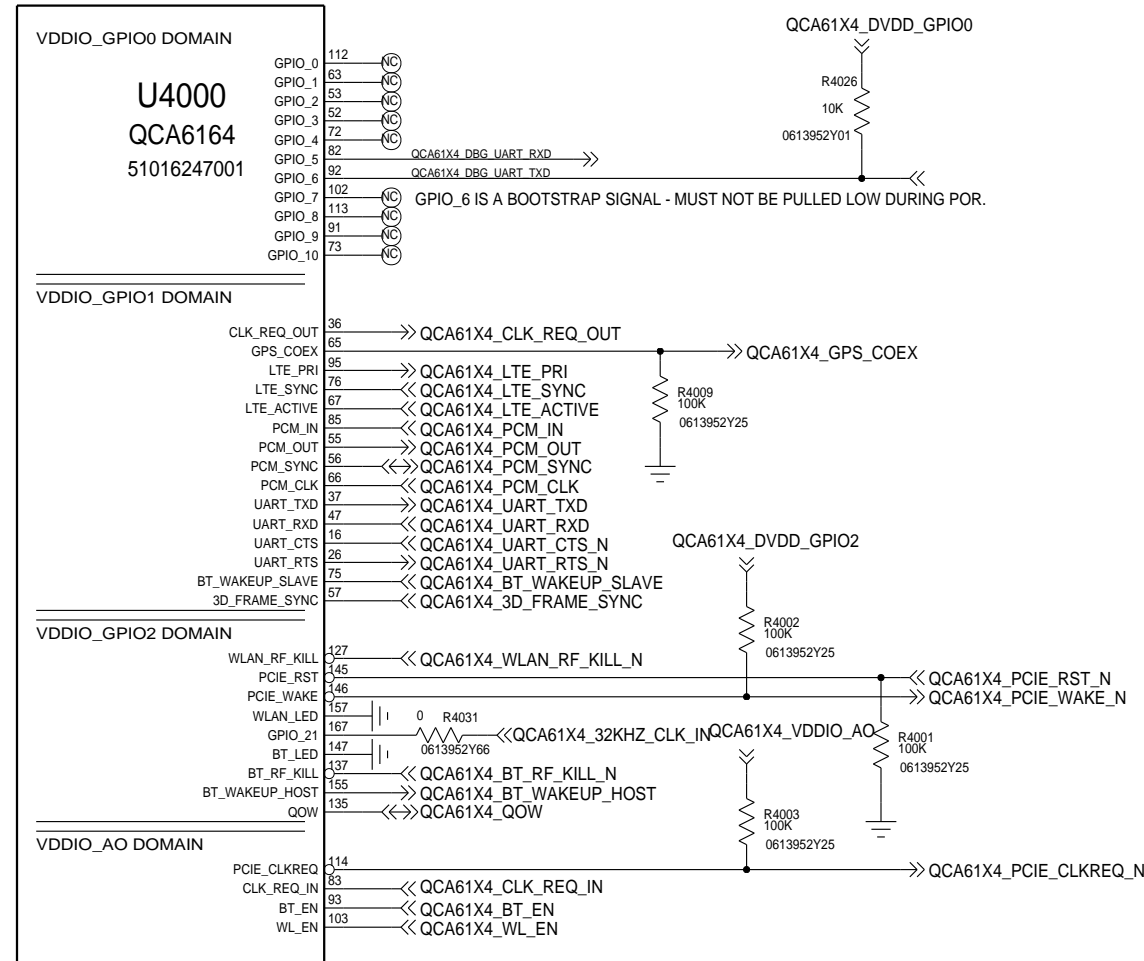

BASED ON 80-WL400/405-42 REV. B

MOTOROLA MOBILITY CONFIDENTIAL RESTRICTED-MDB TRACKED TRACKEDANDBLOCKED

APPROVALS		<b>MOTOROLA</b> MOBILE DEVICES	
ENGINEER: FROEHLING		BLOCK TITLE:	
LAST MODIFIED BY: FROEHLING Thu Jun 05 15:25:39 2014		<b>connectivity</b>	
MOTOROLA CONFIDENTIAL RESTRICTED <small>THE DRAWING ON THIS PRINT AND INFORMATION THEREWITH ARE PROPRIETARY TO MOTOROLA AND SHALL NOT BE USED OR DISCUSSED IN WHOLE OR IN PART WITHOUT MOTOROLA'S CONSENT. © COPYRIGHT, MOTOROLA. THIS DOES NOT IMPLY PUBLICATION</small>		PROJECT NAME	REV
		B 84016326001_a.cpm	01
CAD FILE NAME:		PAGE 38 OF 77	

# CONN: QCA6164 POWER

## REF 4000-4099

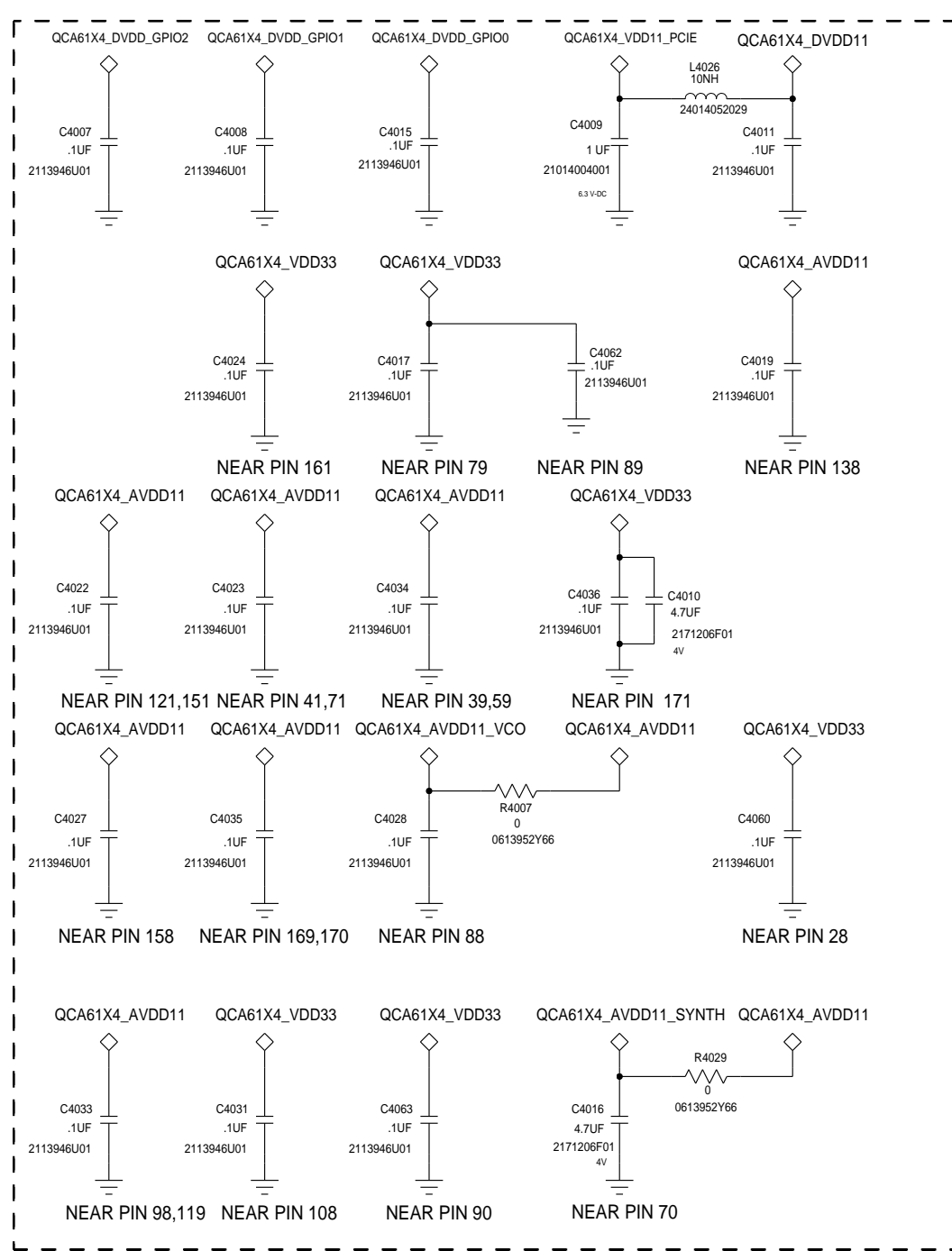
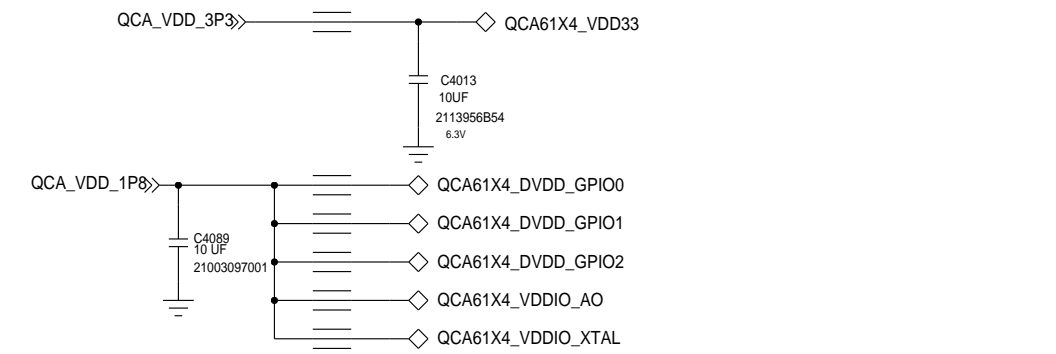

BASED ON 80-WL400-42 REV. B

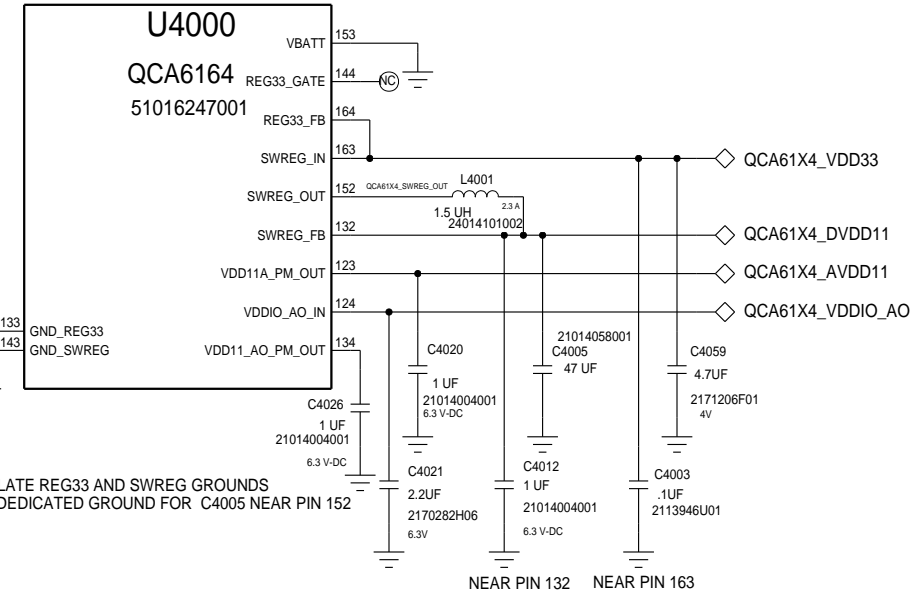
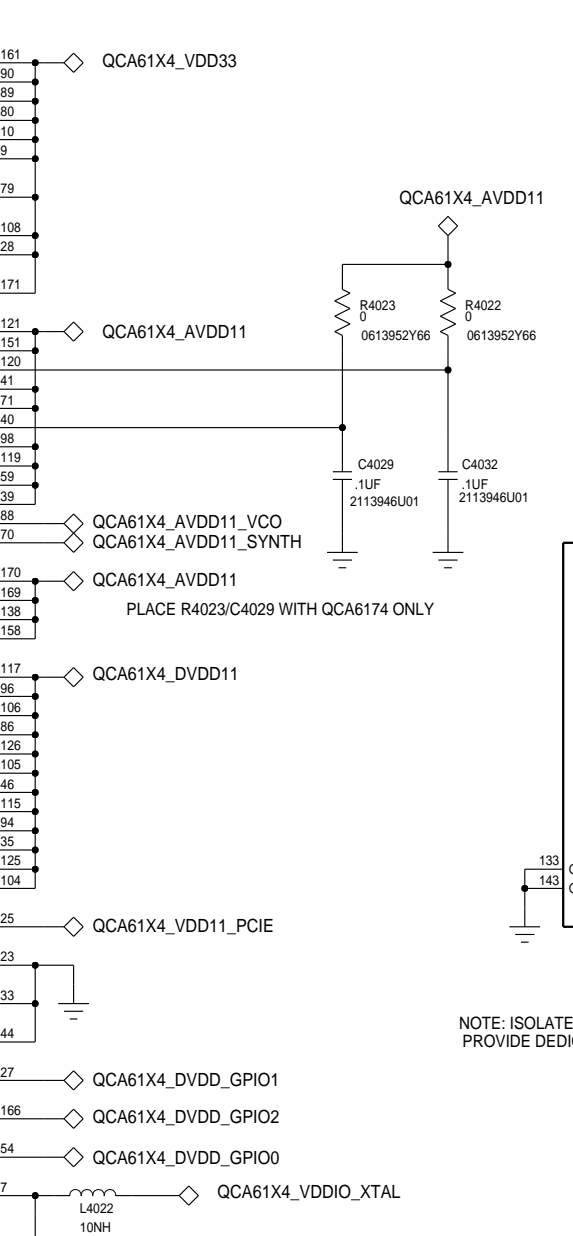
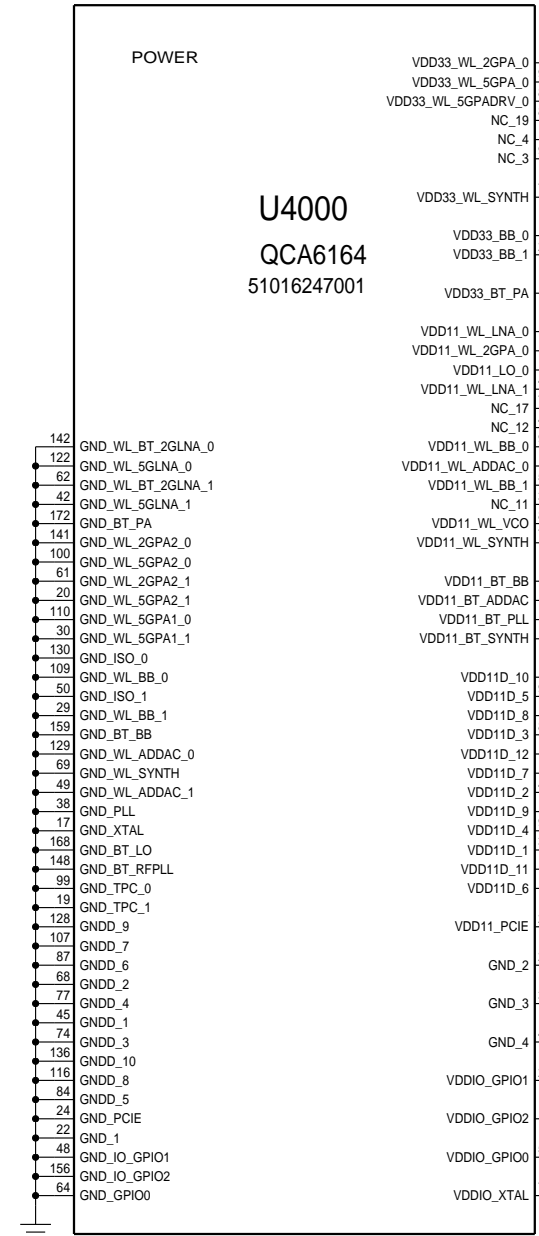

NOTE: ISOLATE REG33 AND SWREG GROUNDS  
PROVIDE DEDICATED GROUND FOR C4005 NEAR PIN 152

MOTOROLA MOBILITY CONFIDENTIAL RESTRICTED-MDB TRACKED TRACKEDANDBLOCKED

APPROVALS		<b>MOTOROLA</b> MOBILE DEVICES	
ENGINEER: FROEHLING		BLOCK TITLE:	
LAST MODIFIED BY: FROEHLING Thu Jun 05 15:25:40 2014		<b>connectivity</b>	
MOTOROLA CONFIDENTIAL RESTRICTED <small>THE DRAWING ON THIS PRINT AND INFORMATION THEREWITH ARE PROPRIETARY TO MOTOROLA AND SHALL NOT BE USED OR DISCUSSED IN WHOLE OR IN PART WITHOUT MOTOROLA'S CONSENT. © COPYRIGHT, MOTOROLA. THIS DOES NOT IMPLY PUBLICATION</small>		PROJECT NAME	REV
		B 84016326001_a.cpm	01
CAD FILE NAME:		PAGE 39 OF 77	

# CONN: QCA6164 RADIO/XTAL

## REF 4000-4099

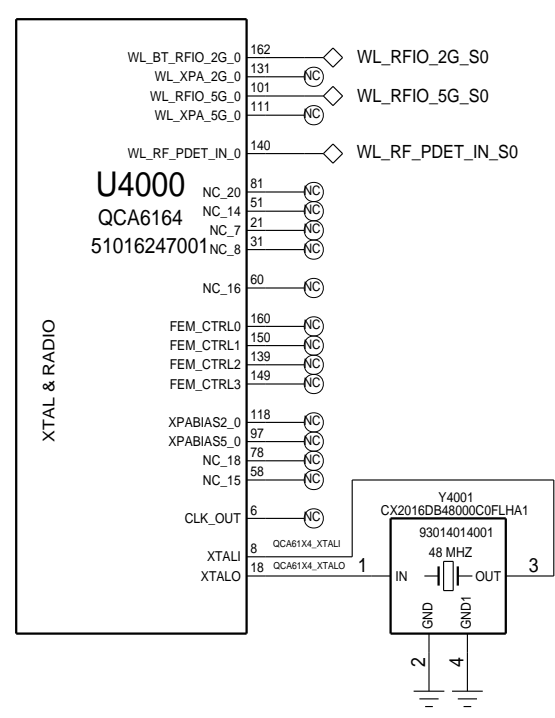
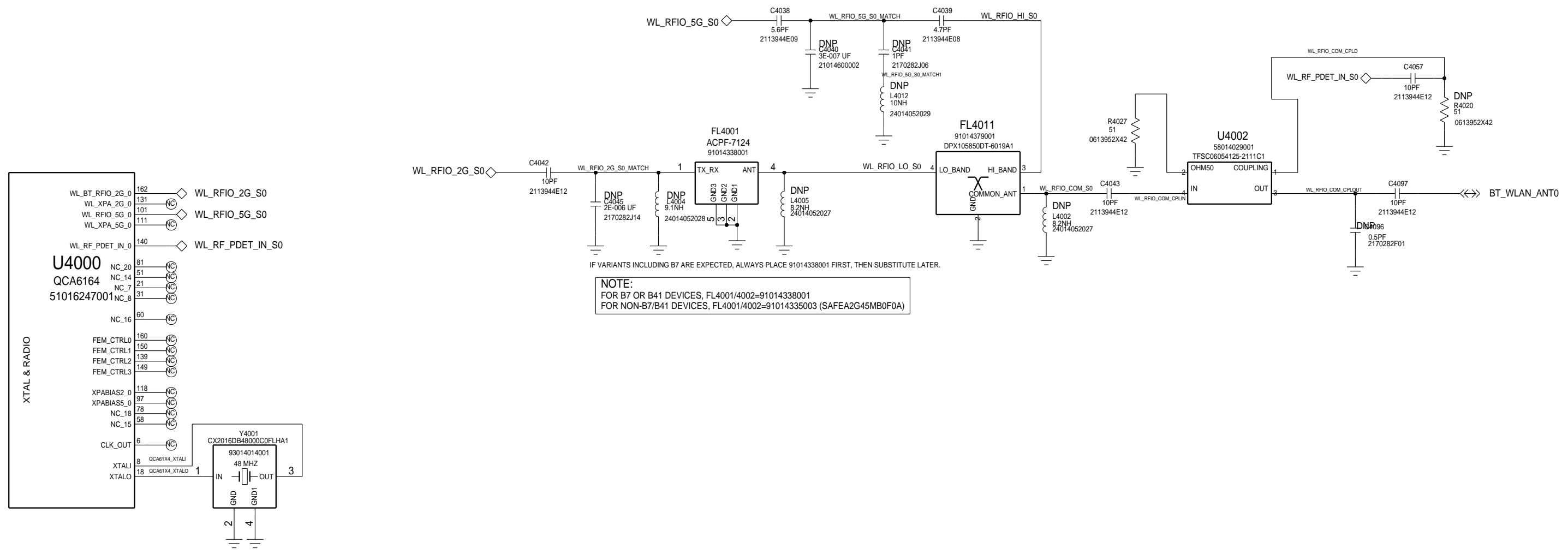

BASED ON 80-WL400-42 REV. B

MOTOROLA MOBILITY CONFIDENTIAL RESTRICTED-MDB TRACKED TRACKEDANDBLOCKED

APPROVALS		<b>MOTOROLA</b> MOBILE DEVICES	
ENGINEER: FROEHLING		BLOCK TITLE:	
LAST MODIFIED BY: FROEHLING Thu Jun 12 13:30:12 2014		<b>connectivity</b>	
MOTOROLA CONFIDENTIAL RESTRICTED <small>THE DRAWING ON THIS PRINT AND INFORMATION THEREWITH ARE PROPRIETARY TO MOTOROLA AND SHALL NOT BE USED OR DISCUSSED IN WHOLE OR IN PART WITHOUT MOTOROLA'S CONSENT. © COPYRIGHT, MOTOROLA. THIS DOES NOT IMPLY PUBLICATION</small>		PROJECT NAME	REV
		B 84016326001_a.cpm	01
CAD FILE NAME:		PAGE 40 OF 77	



# CONN: BCM20795 NFC

REF: 4100-4199

I2C ADDR: 0X77 (BOOT DEFAULT WHEN PIN 3 IS PULLED TO GROUND)

OR

I2C ADDR: 0X76 (BOOT DEFAULT WHEN PIN 3 IS FLOATED/PULLED HIGH)

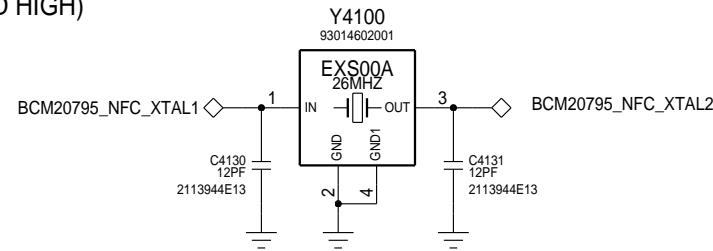

\* SEE NOTE 1

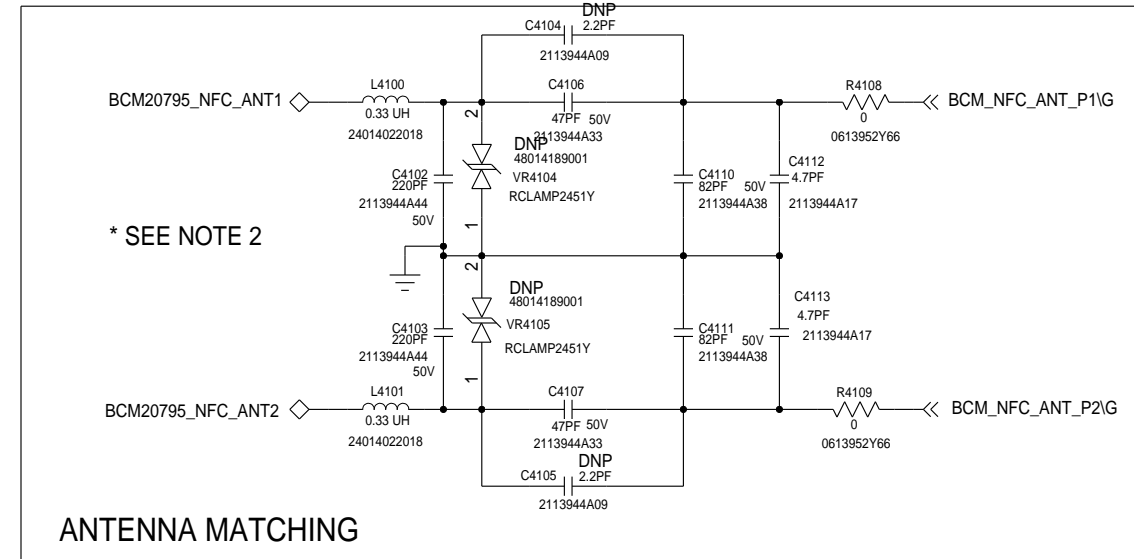
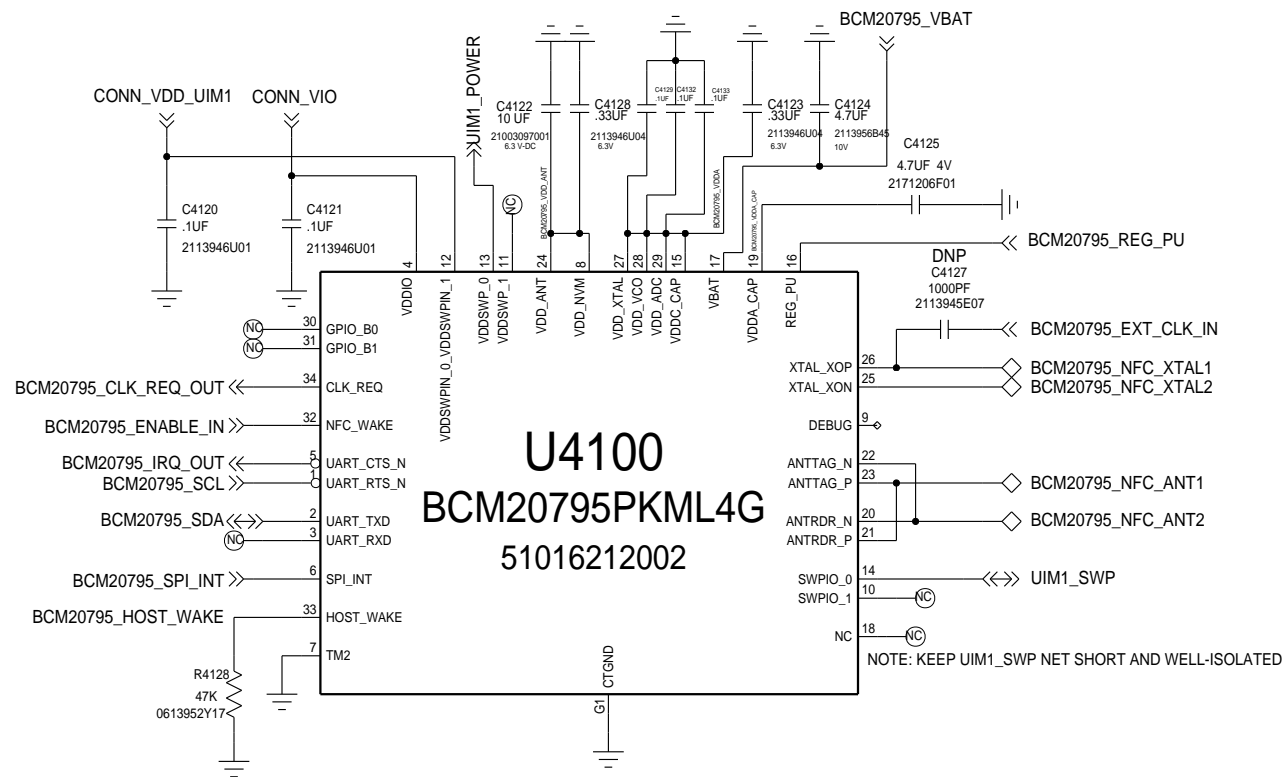

ANTENNA MATCHING

REFERENCE DESIGNATOR	26 MHZ CRYSTAL OSCILLATOR	19.2 MHZ EXTERNAL CLOCK
C4130	PLACE	DNI
C4131	PLACE	DNI
C4127	DNI	PLACE
Y4100	PLACE	DNI

NOTES:

- PER BROADCOM RECOMMENDATION, CAPACITANCE ON UIM1\_POWER NET SHOULD BE 0.33UF. TOO LITTLE COMPROMISES REGULATOR STABILITY, TOO MUCH CAN CAUSE INADVERTENT POWER-ON RESETS AT VDD.
- L5900W AND L5901W PLACEMENT MUST MINIMIZE MUTUAL INDUCTIVE COUPLING, OR CIRCUIT'S WIRELESS FUNCTION WILL BE SEVERELY IMPAIRED.

MOTOROLA MOBILITY CONFIDENTIAL RESTRICTED-MDB TRACKED TRACKEDANDBLOCKED

APPROVALS		 MOTOROLA MOBILE DEVICES	
ENGINEER: FROEHLING		BLOCK TITLE:	
LAST MODIFIED BY: FROEHLING		connectivity	
MOTOROLA CONFIDENTIAL RESTRICTED		PROJECT NAME	REV
THE DRAWING ON THIS PRINT AND INFORMATION THEREWITH ARE PROPRIETARY TO MOTOROLA AND SHALL NOT BE USED OR DISCUSSED IN WHOLE OR IN PART WITHOUT MOTOROLA'S CONSENT. © COPYRIGHT, MOTOROLA. THIS DOES NOT IMPLY PUBLICATION		B 84016326001_a.cpm	01
		CAD FILE NAME:	

# CONN: UIM1

## REF:4200-4219

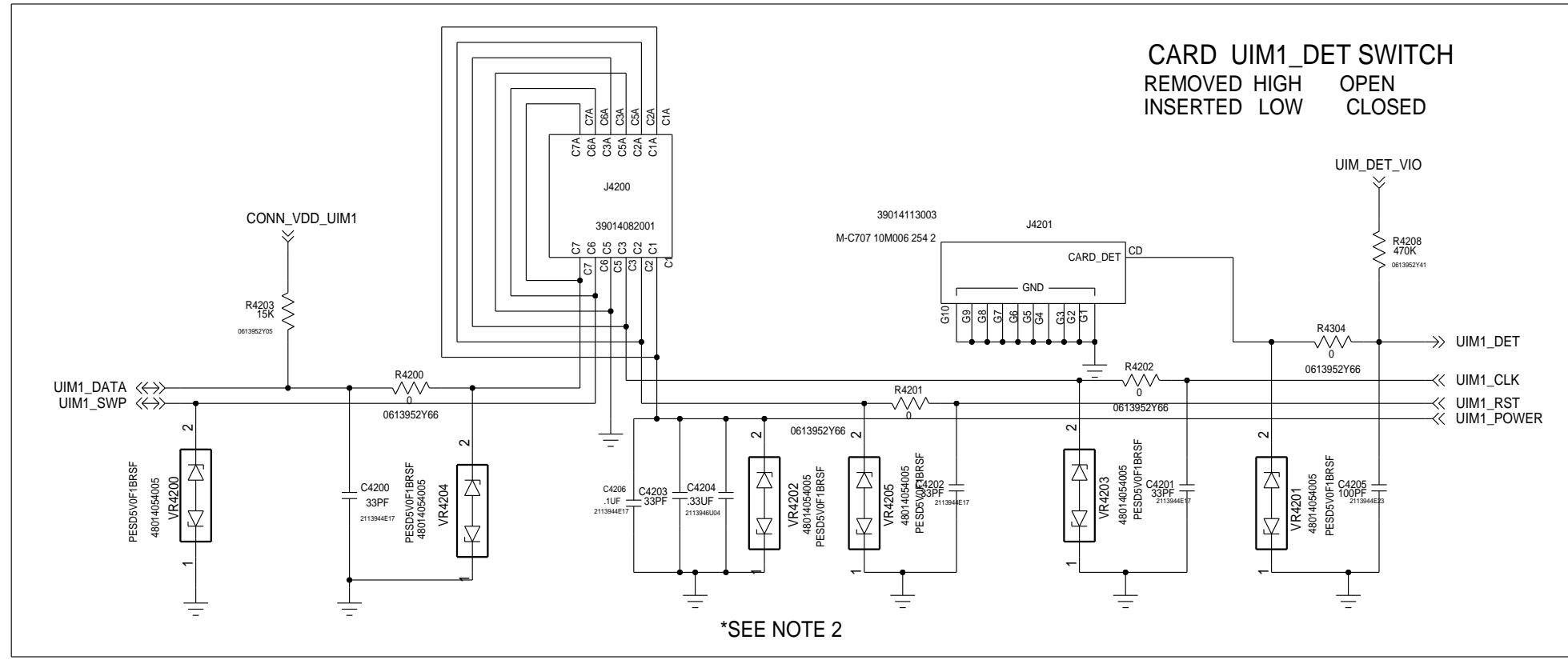

NOTE 1: DELETED  
 NOTE 2: UIM\_PWR BYPASS OF 0.33UF RECOMMENDED BY NFC IC SUPPLIER, PLACE NEAR CONNECTOR.

APPROVALS		<b>MOTOROLA</b> MOBILE DEVICES	
ENGINEER: FROEHLING		BLOCK TITLE:	
LAST MODIFIED BY: FROEHLING Thu Jun 05 15:25:42 2014		<b>connectivity</b>	
MOTOROLA CONFIDENTIAL RESTRICTED <small>THE DRAWING ON THIS PRINT AND INFORMATION THEREWITH ARE PROPRIETARY TO MOTOROLA AND SHALL NOT BE USED OR DISCUSSED IN WHOLE OR IN PART WITHOUT MOTOROLA'S CONSENT. © COPYRIGHT, MOTOROLA. THIS DOES NOT IMPLY PUBLICATION</small>		PROJECT NAME <b>B</b> 84016326001_a.cpm	REV 01
		CAD FILE NAME:	
		PAGE 42 OF 77	

8 7 6 5 4 3 2 1

D

C

B

A

D

C

B

A

8 7 6 5 4 3 2 1

# XMCS: POWER

REF 6000-6999

## SUPPLIES

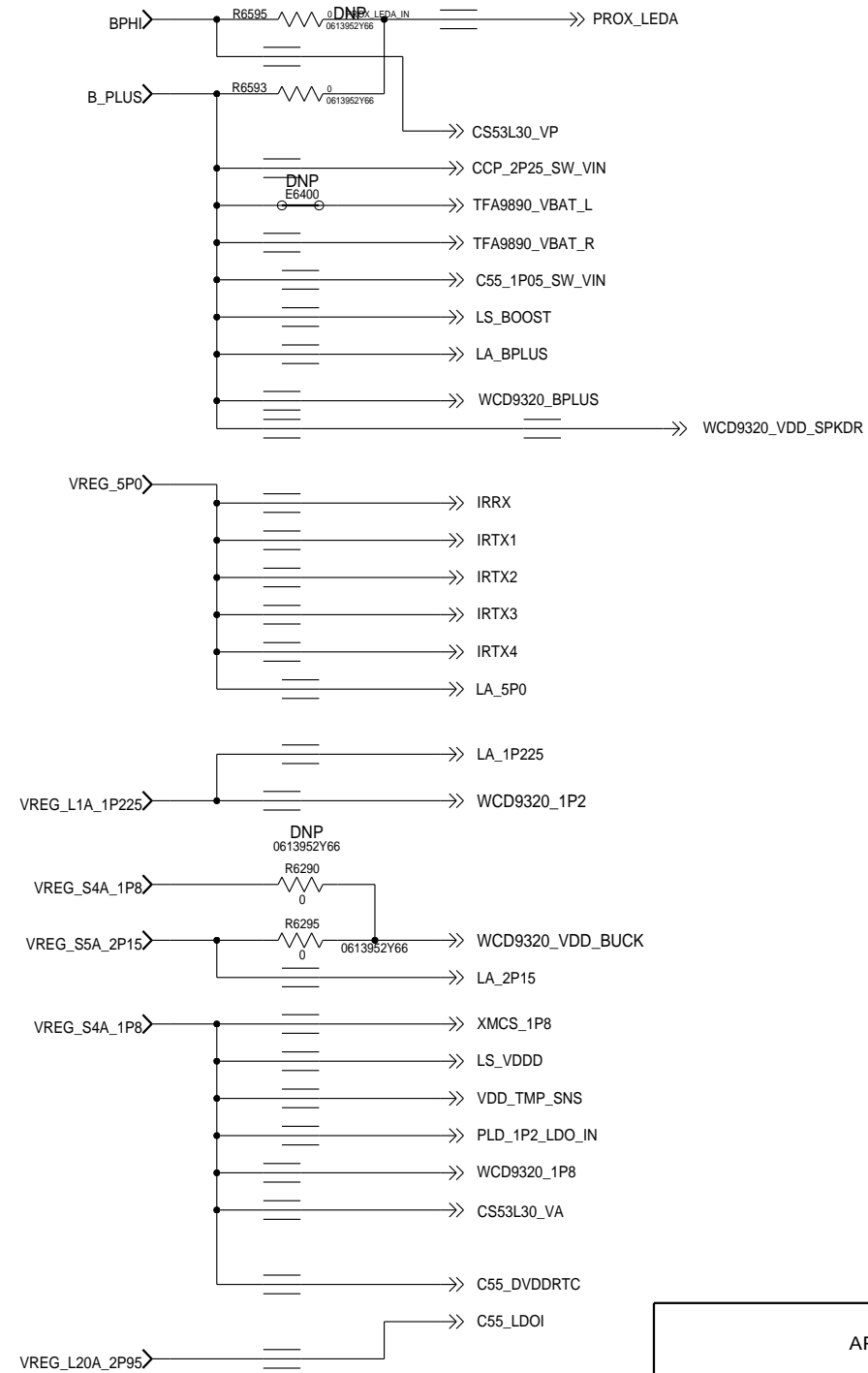
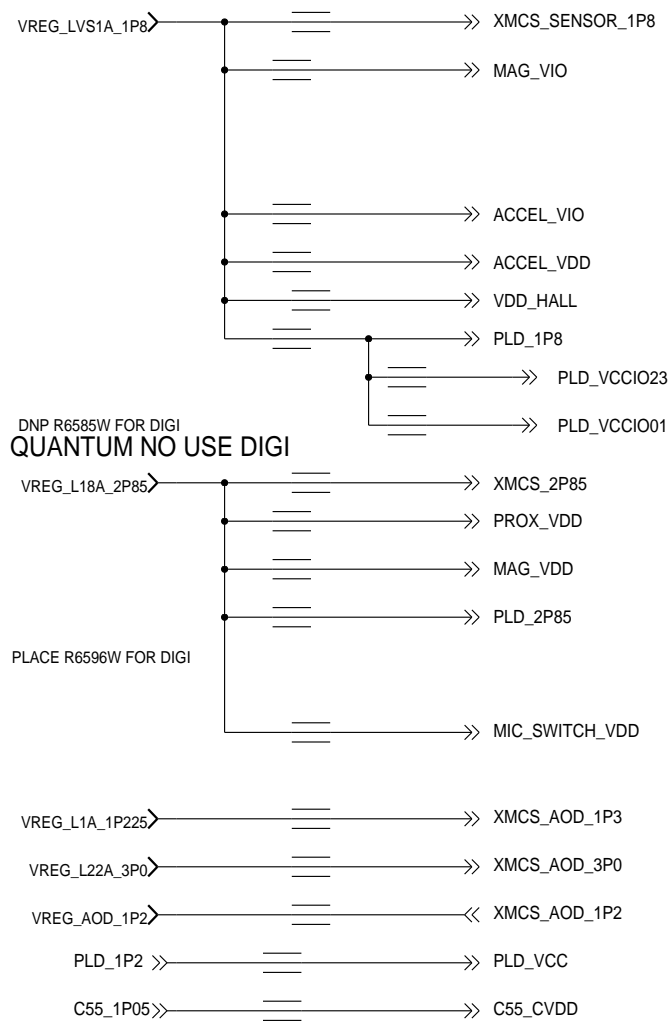

APPROVALS		<b>MOTOROLA</b> MOBILE DEVICES	
ENGINEER: NATE CONNELL		BLOCK TITLE:	
LAST MODIFIED BY: NATE CONNELL Thu Jun 05 15:25:29 2014		<b>xmcs</b>	
MOTOROLA CONFIDENTIAL RESTRICTED		PROJECT NAME	REV
<small>THE DRAWING ON THIS PRINT AND INFORMATION THEREWITH ARE PROPRIETARY TO MOTOROLA AND SHALL NOT BE USED OR DISCUSSED IN WHOLE OR IN PART WITHOUT MOTOROLA'S CONSENT. © COPYRIGHT, MOTOROLA. THIS DOES NOT IMPLY PUBLICATION</small>		B 84016326001_a.cpm	01
		CAD FILE NAME:	
		PAGE 43 OF 77	

# XMCS: PORTS

REF 6000-6999

## INTERFACES

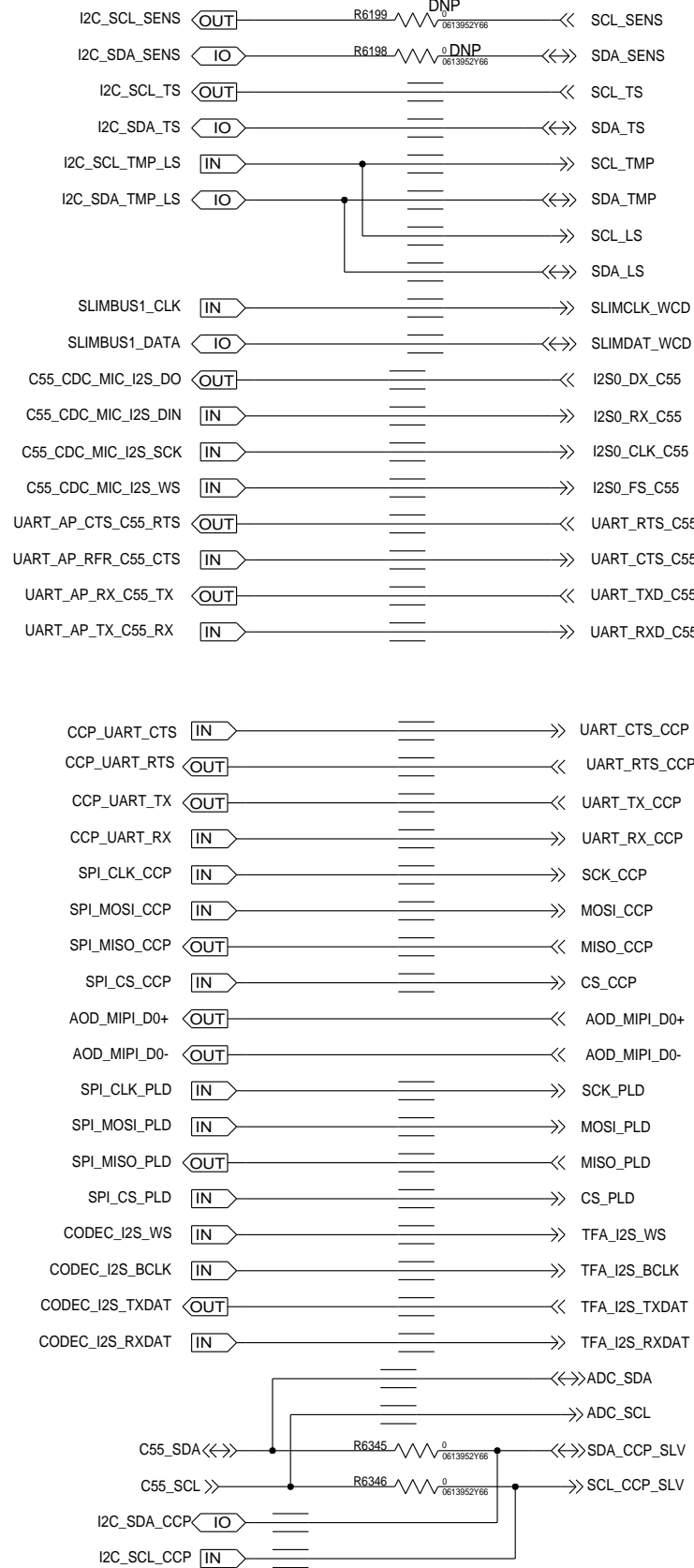

## INPUTS

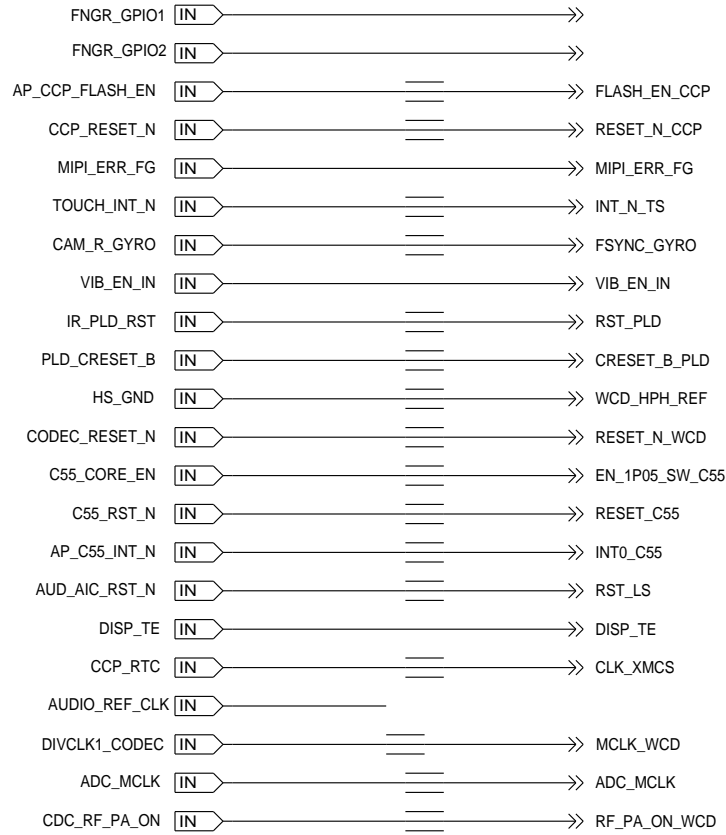

## SPEAKER PATHS

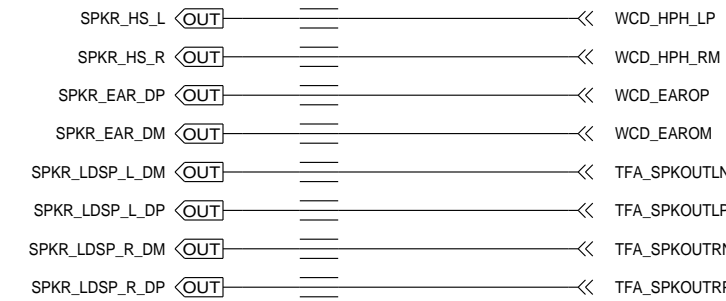

## OUTPUTS

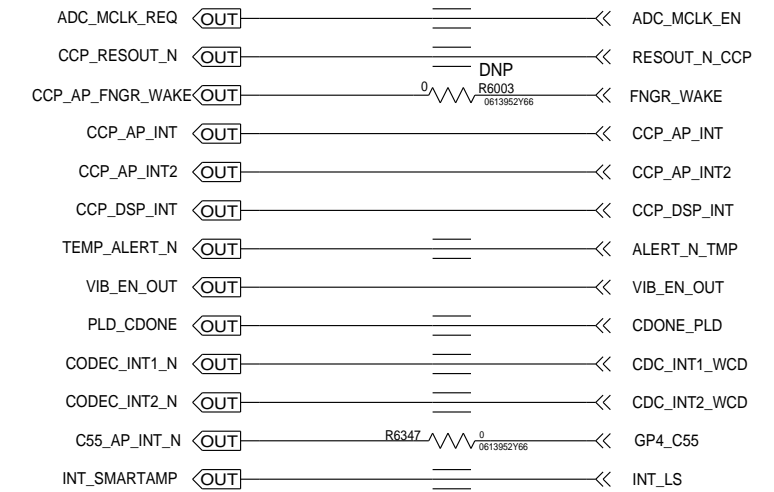

## MIC PATHS

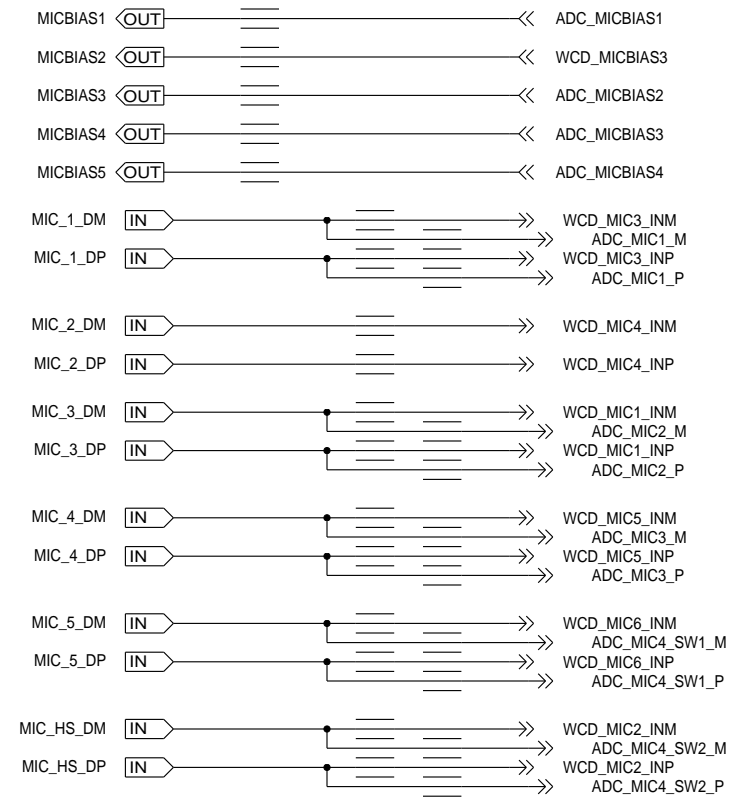

### APPROVALS

ENGINEER: NATE CONNELL

LAST MODIFIED BY: NATE CONNELL  
Fri Mar 21 18:25:27 2014

MOTOROLA CONFIDENTIAL RESTRICTED

THE DRAWING ON THIS PRINT AND INFORMATION  
THEREWITH ARE PROPRIETARY TO MOTOROLA AND  
SHALL NOT BE USED OR DISCUSSED IN WHOLE  
OR IN PART WITHOUT MOTOROLA'S CONSENT.  
© COPYRIGHT, MOTOROLA. THIS DOES  
NOT IMPLY PUBLICATION



BLOCK TITLE:

xmcs

PROJECT NAME  
84016326001\_a.cpm

CAD FILE NAME:

REV  
01

# XMCS: CCP

REF: 6000-6049

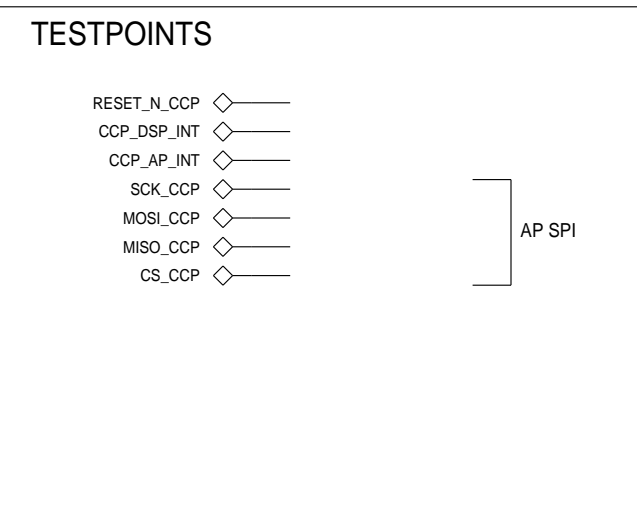
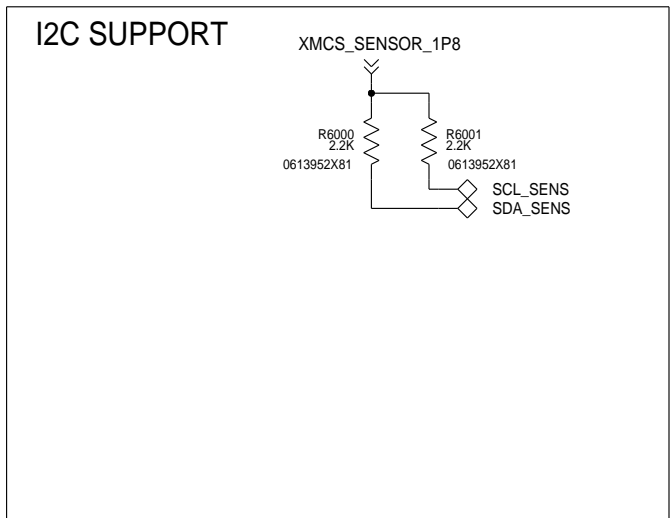
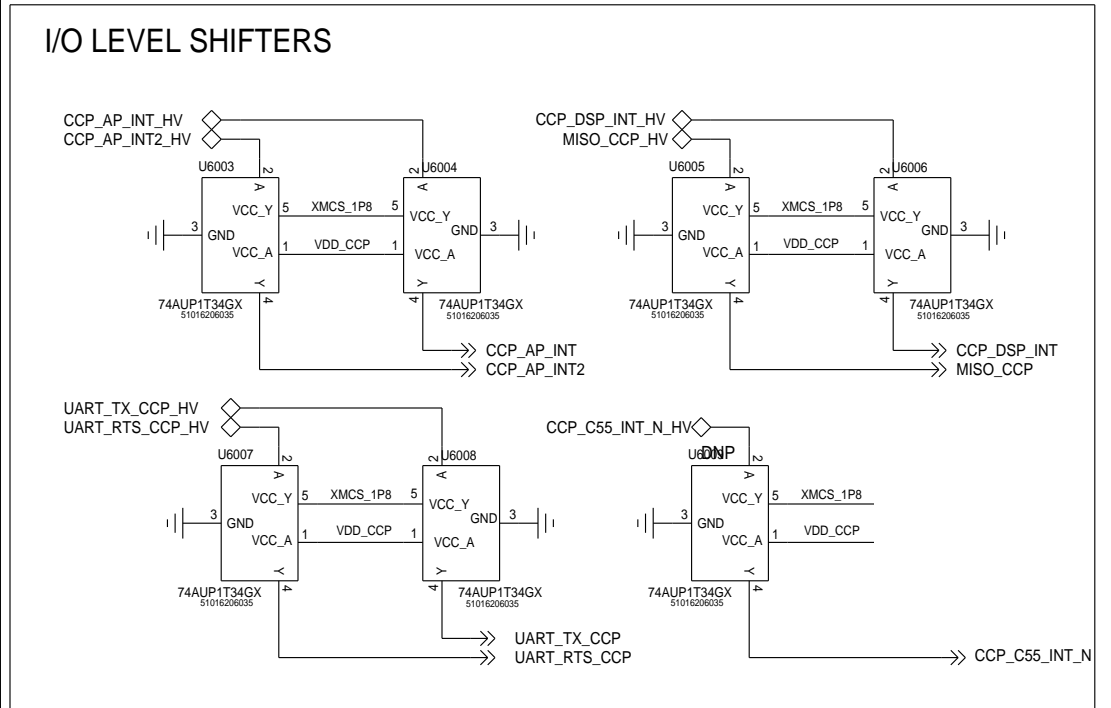
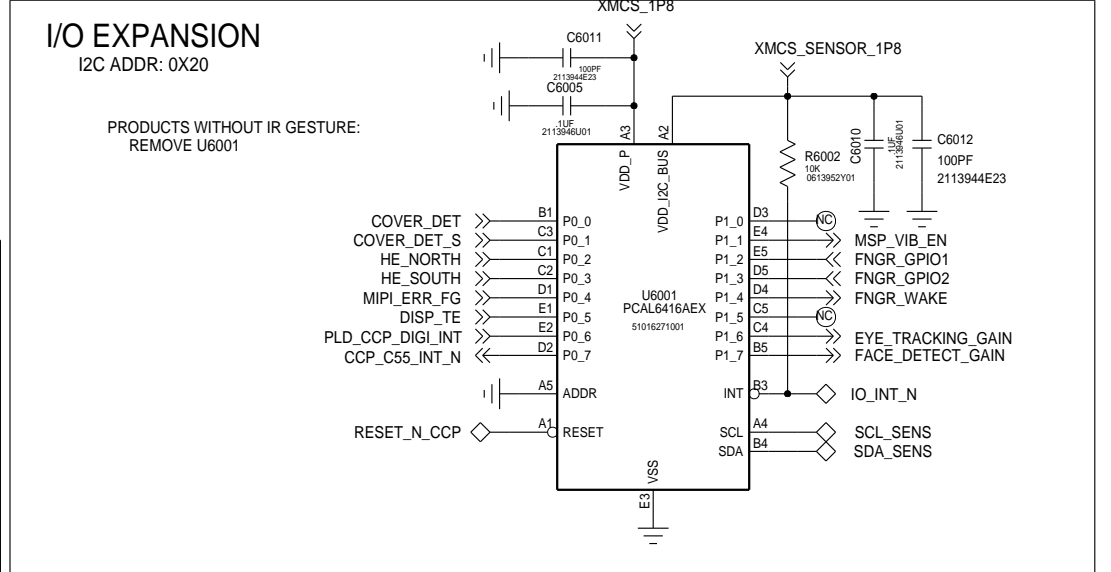
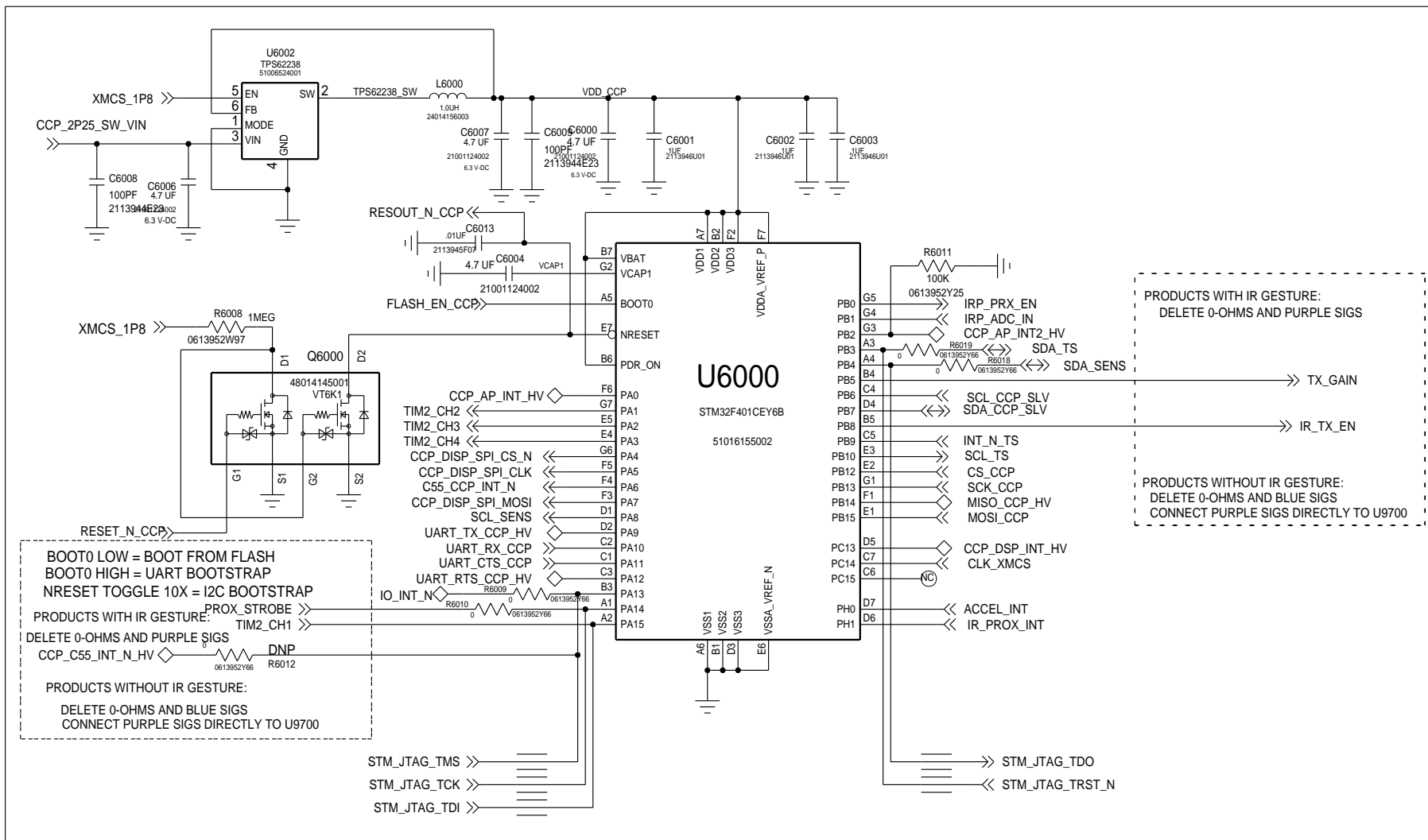

APPROVALS		<b>MOTOROLA</b> MOBILE DEVICES	
ENGINEER: JOHN GORSICA		BLOCK TITLE:	
LAST MODIFIED BY: NATE CONNELL Mon Jun 09 12:38:07 2014		<b>xmcs</b>	
MOTOROLA CONFIDENTIAL RESTRICTED <small>THE DRAWING ON THIS PRINT AND INFORMATION THEREWITH ARE PROPRIETARY TO MOTOROLA AND SHALL NOT BE USED OR DISCUSSED IN WHOLE OR IN PART WITHOUT MOTOROLA'S CONSENT. © COPYRIGHT, MOTOROLA. THIS DOES NOT IMPLY PUBLICATION</small>		PROJECT NAME	REV
		B 84016326001_a.cpm	01
CAD FILE NAME:		PAGE 45 OF 77	

# XMCS: SENSORS

REF: 6100-6199

## PROX SENSOR/ALS

REF:6120-6129  
I2C ADDR:0X39

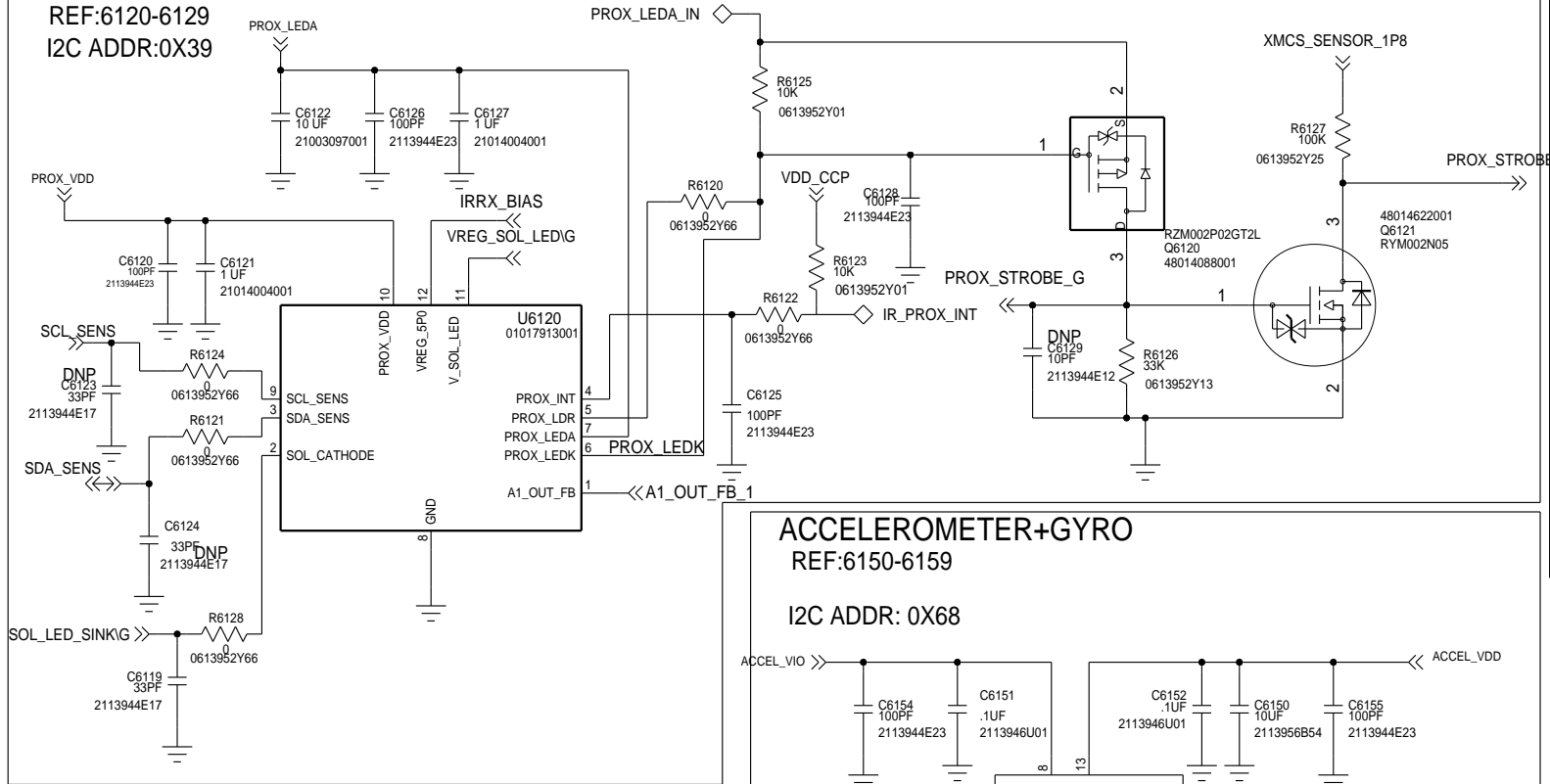

## HALL EFFECT

REF:6170-6179

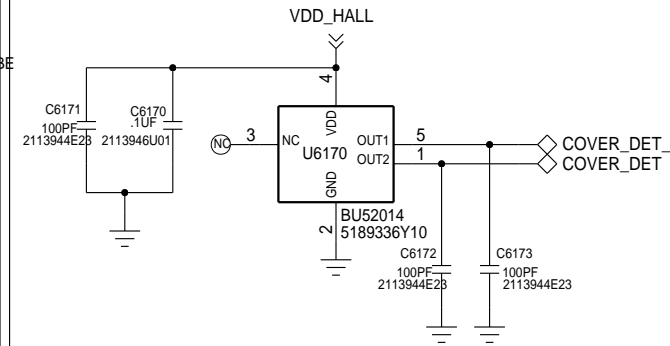

2ND HALL EFFECT FOR SMART COVER SUPPORT

## BOARD TEMP SENSORS

REF:6160-6169

I2C ADDR: 0X48

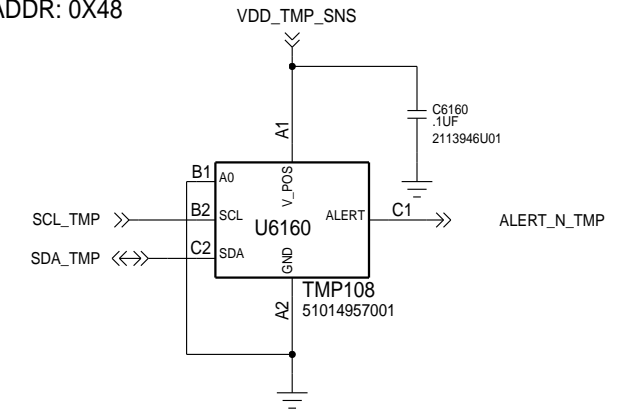

I2C ADDR: 0X49

U6161 DELETED

## ACCELEROMETER+GYRO

REF:6150-6159

I2C ADDR: 0X68

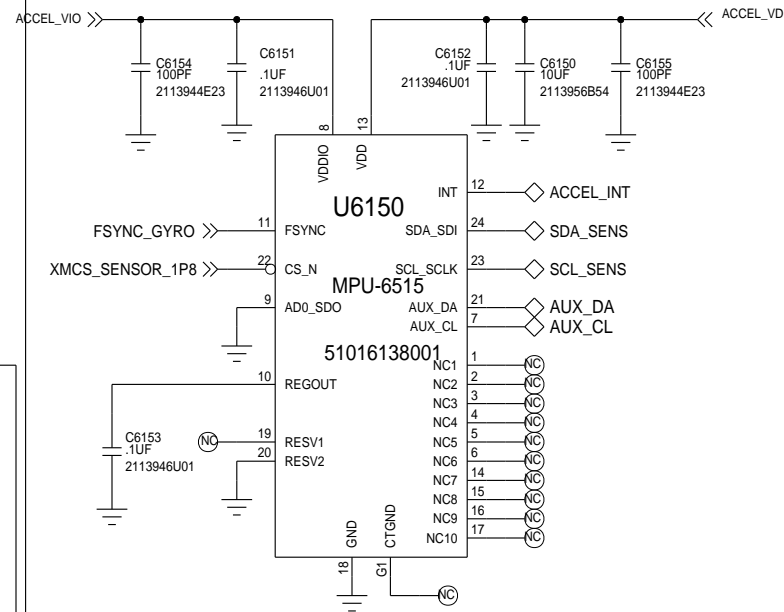

PRODUCTS MUST FOLLOW ABBAGOOCHIE PCB ORIENTATION

## BAROMETER

REF:6130-6139  
I2C ADDR: 0X77

## MAGNETOMETER

REF:6140-6149

I2C ADDR: 0X0C

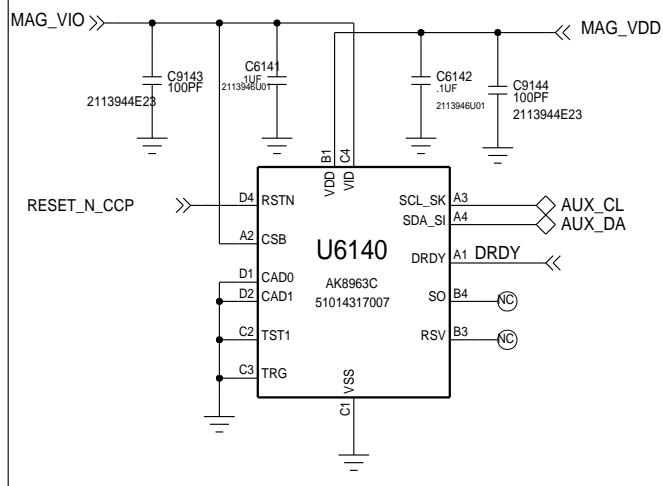

JOHN GORSICA/NATE CONNELL  
APPROVALS

ENGINEER: C HERNANDEZ

LAST MODIFIED BY: C HERNANDEZ  
Thu Jun 05 17:48:59 2014

MOTOROLA CONFIDENTIAL RESTRICTED

THE DRAWING ON THIS PRINT AND INFORMATION  
THEREWITH ARE PROPRIETARY TO MOTOROLA AND  
SHALL NOT BE USED OR DISCUSSED IN WHOLE  
OR IN PART WITHOUT MOTOROLA'S CONSENT.  
© COPYRIGHT, MOTOROLA. THIS DOES  
NOT IMPLY PUBLICATION

**MOTOROLA**  
MOBILE DEVICES

BLOCK TITLE:

**XMCS**

PROJECT NAME

84016326001ABBAGOOCHIE

CAD FILE NAME:

REV  
01

PAGE 46 OF 77

# XMCS: AOD

REF: 6050-6059

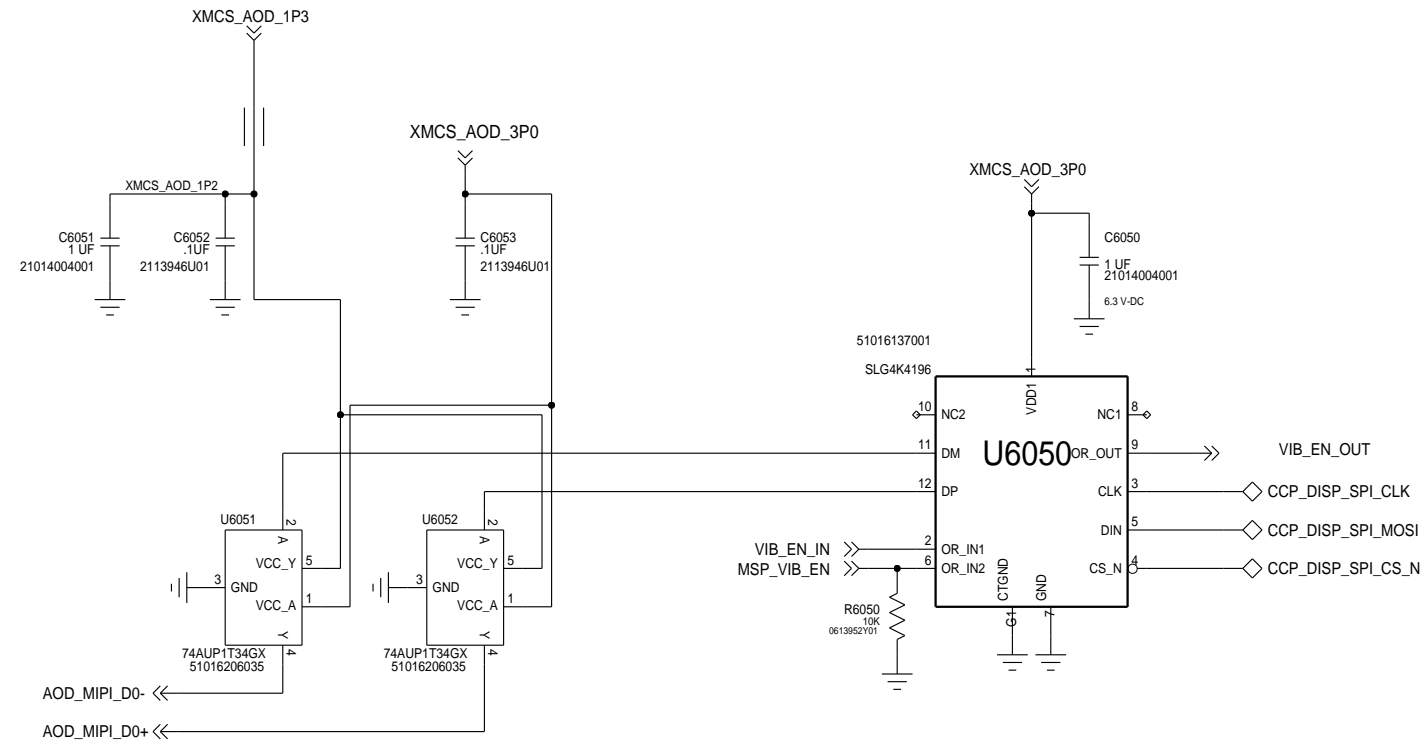

APPROVALS		 <b>MOTOROLA</b> MOBILE DEVICES	
ENGINEER: MOTOROLA		BLOCK TITLE:	
LAST MODIFIED BY: MOTOROLA Thu Jun 05 15:25:31 2014		<b>xmcs</b>	
MOTOROLA CONFIDENTIAL RESTRICTED <small>THE DRAWING ON THIS PRINT AND INFORMATION THEREWITH ARE PROPRIETARY TO MOTOROLA AND SHALL NOT BE USED OR DISCUSSED IN WHOLE OR IN PART WITHOUT MOTOROLA'S CONSENT.          © COPYRIGHT, MOTOROLA. THIS DOES NOT IMPLY PUBLICATION</small>		PROJECT NAME	REV
		B 84016326001_a.cpm	01
		CAD FILE NAME:	
		PAGE 47 OF 77	

# XMCS: NATIVE IR

REF: 6060-6069

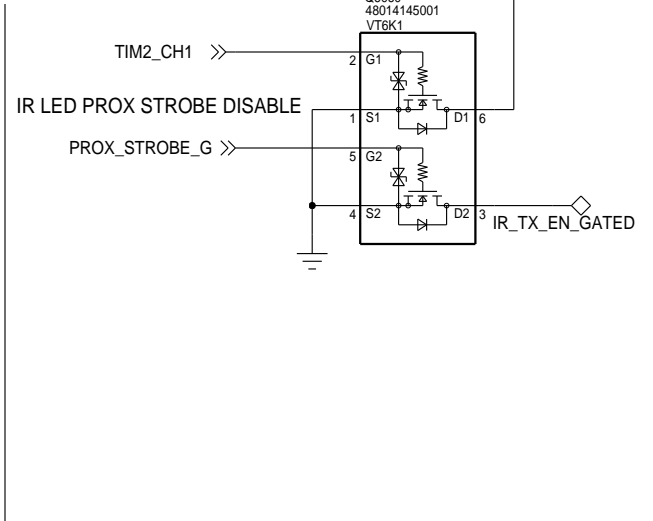
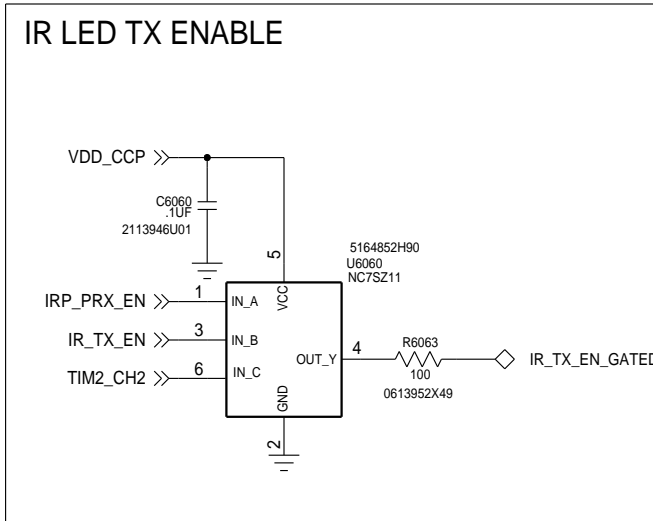
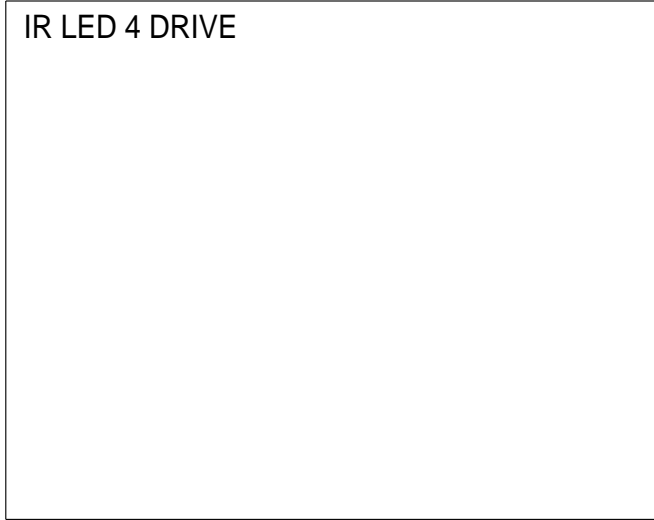
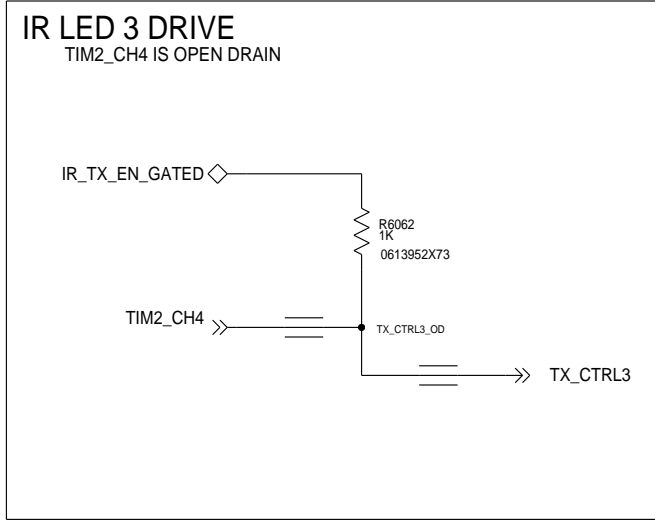
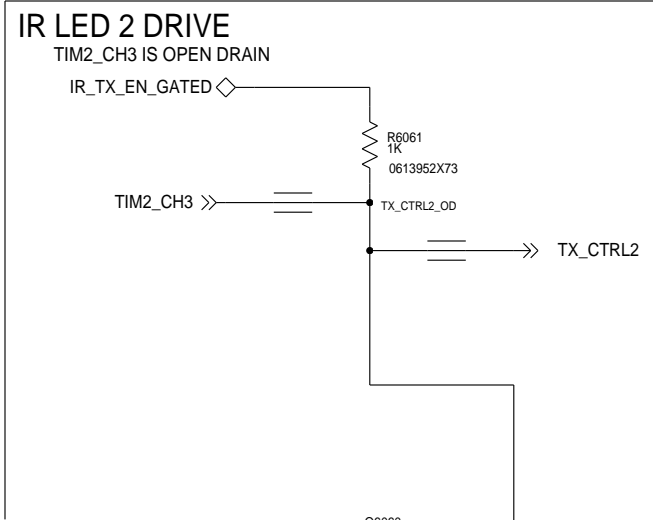
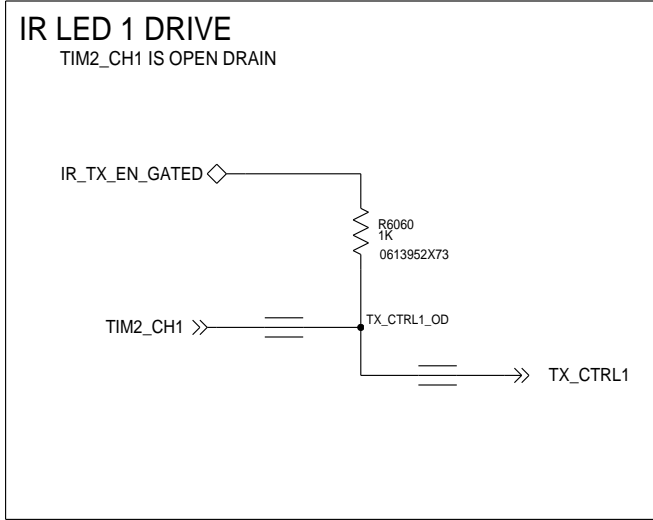

APPROVALS		<b>MOTOROLA</b> MOBILE DEVICES	
ENGINEER: NATE CONNELL		BLOCK TITLE:	
LAST MODIFIED BY: NATE CONNELL Mon Jun 09 12:39:30 2014		<b>xmcs</b>	
MOTOROLA CONFIDENTIAL RESTRICTED <small>THE DRAWING ON THIS PRINT AND INFORMATION THEREWITH ARE PROPRIETARY TO MOTOROLA AND SHALL NOT BE USED OR DISCUSSED IN WHOLE OR IN PART WITHOUT MOTOROLA'S CONSENT. © COPYRIGHT, MOTOROLA. THIS DOES NOT IMPLY PUBLICATION</small>		PROJECT NAME <b>B</b> 84016326001_a.cpm	REV 01
		CAD FILE NAME:	
		PAGE 48 OF 77	



# XMCS: FPGA IR

REF: 6500-6599

## FPGA IR DELETED

D

D

C

C

B

B

A

A

APPROVALS		 <b>MOTOROLA</b> MOBILE DEVICES	
ENGINEER: MOTOROLA		BLOCK TITLE:	
LAST MODIFIED BY: MOTOROLA Tue Jan 14 15:56:44 2014		<b>xmcs</b>	
MOTOROLA CONFIDENTIAL RESTRICTED <small>THE DRAWING ON THIS PRINT AND INFORMATION THEREWITH ARE PROPRIETARY TO MOTOROLA AND SHALL NOT BE USED OR DISCUSSED IN WHOLE OR IN PART WITHOUT MOTOROLA'S CONSENT. © COPYRIGHT, MOTOROLA. THIS DOES NOT IMPLY PUBLICATION</small>		PROJECT NAME <b>B</b> 84016326001_a.cpm	REV 01
		CAD FILE NAME:	PAGE 49 OF 77

# XMCS: IR LED

REF 6500-6549

## GESTURE BOOST

FOR 10V OPERATION, R6592 = 140K (0613952W15)  
 FOR 12V OPERATION, R6592 = 113K (0613952W06)

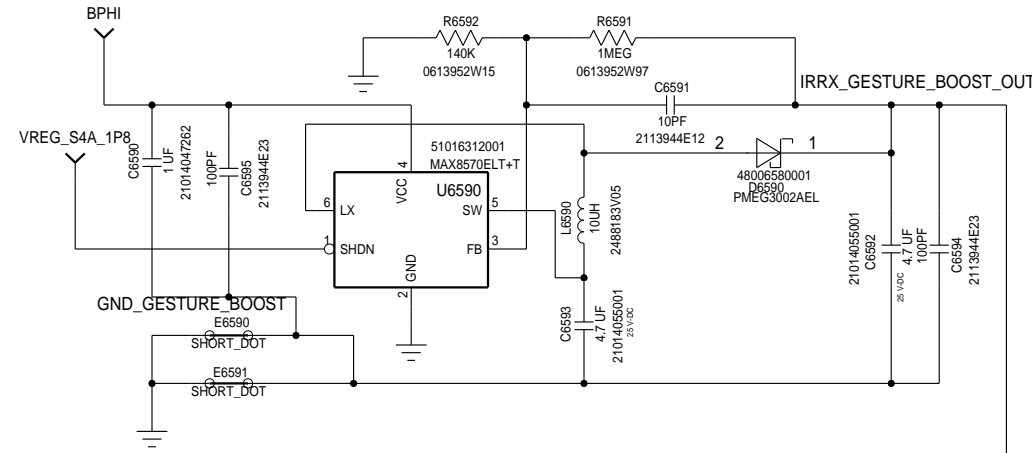

## IR RECEIVER

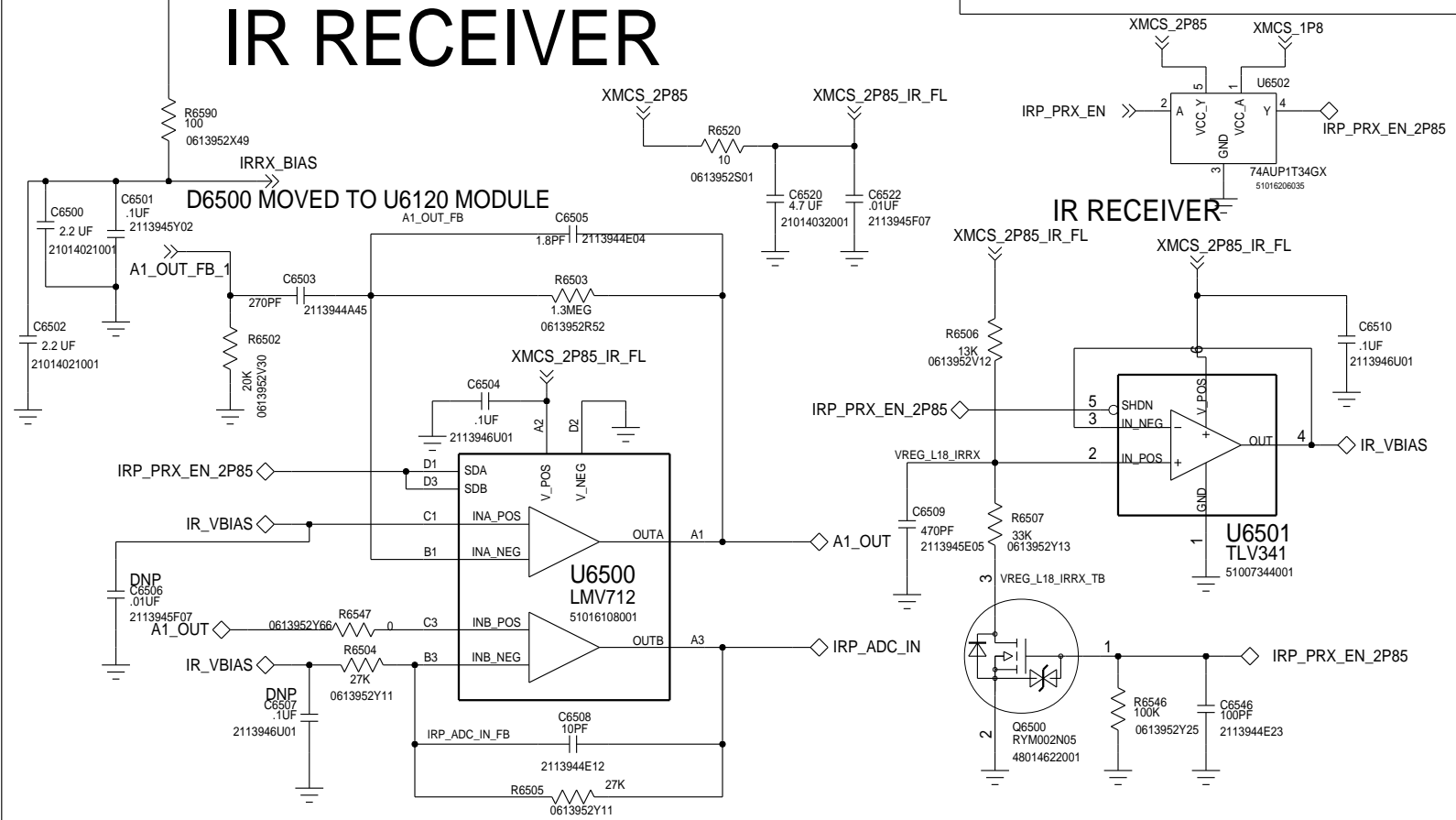

## IR TRANSMITTER

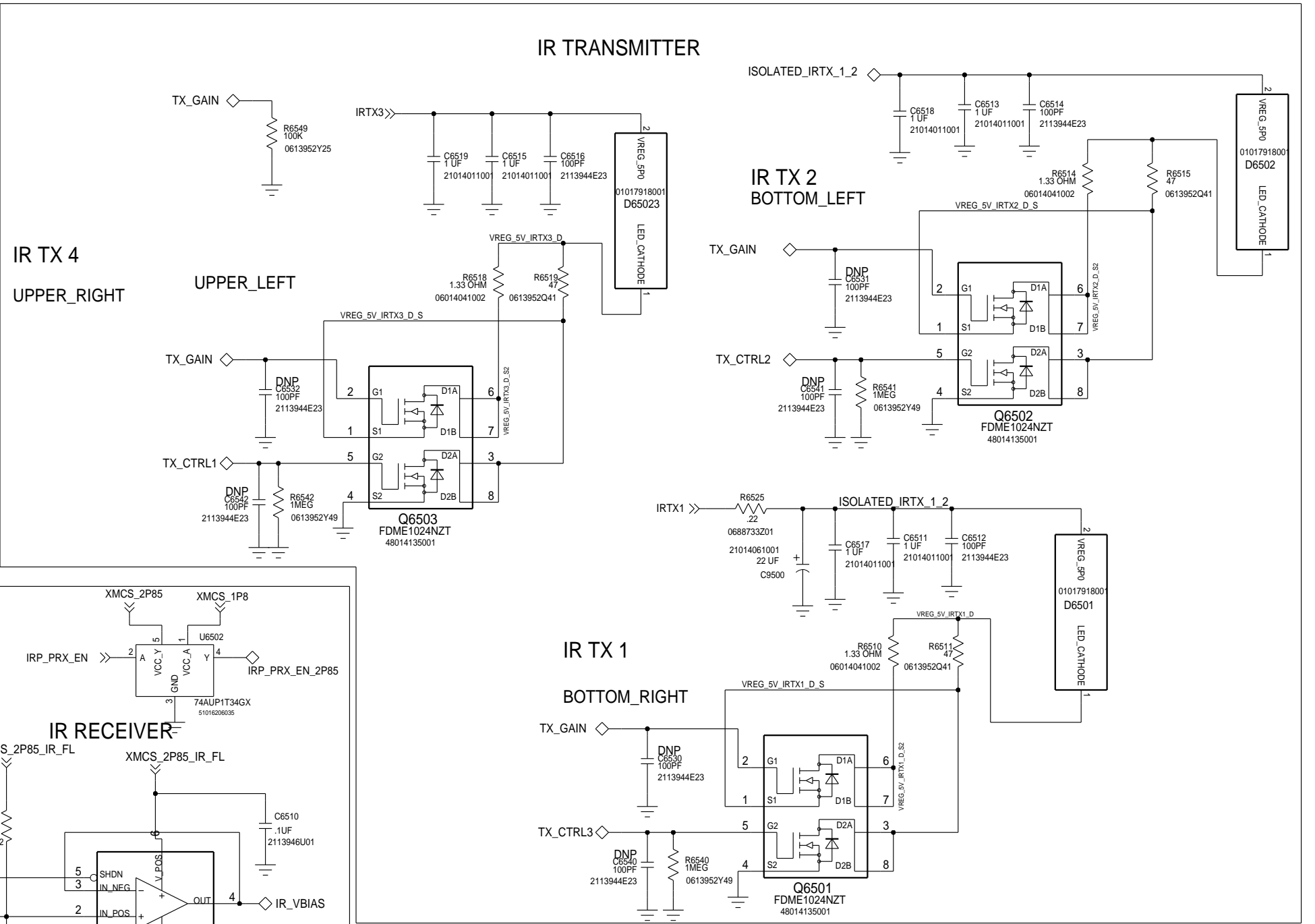

APPROVALS		<b>MOTOROLA</b> MOBILE DEVICES	
ENGINEER: MATT MOTTIER		BLOCK TITLE: <b>xmcs</b>	
LAST MODIFIED BY: UDI ELRAN Wed Jul 09 12:28:06 2014		PROJECT NAME 84016326001_a.cpm	
MOTOROLA CONFIDENTIAL RESTRICTED		REV 01	
THE DRAWING ON THIS PRINT AND INFORMATION THEREWITH ARE PROPRIETARY TO MOTOROLA AND SHALL NOT BE USED OR DISCUSSED IN WHOLE OR IN PART WITHOUT MOTOROLA'S CONSENT. © COPYRIGHT, MOTOROLA. THIS DOES NOT IMPLY PUBLICATION		PAGE 50 OF 77	

# XMCS: CODEC

REF 6250-6299

## WCD9320

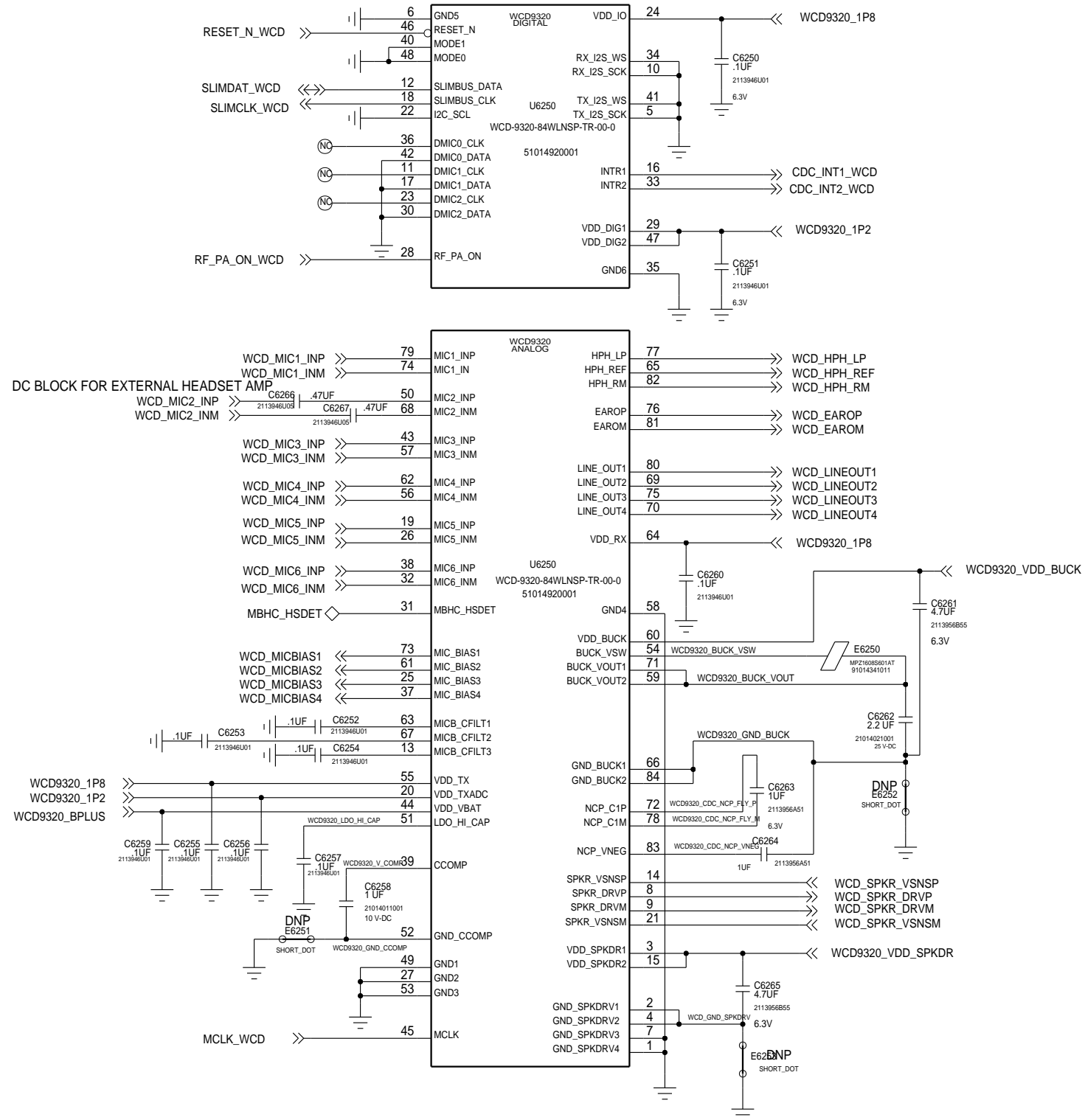

## CIRRUS ADC

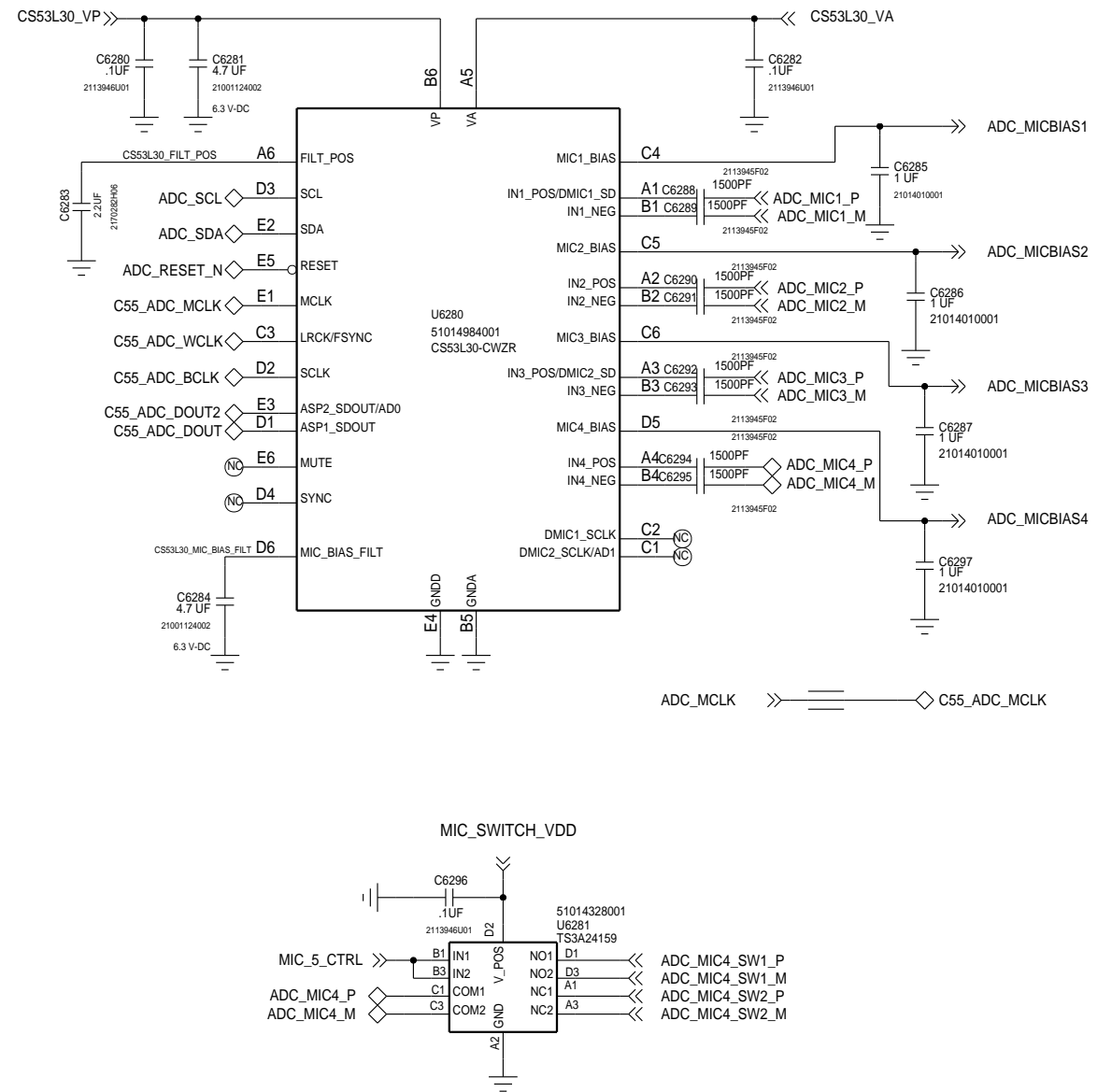

MOTOROLA MOBILITY CONFIDENTIAL RESTRICTED-MDB TRACKED TRACKEDANDBLOCKED

APPROVALS		<b>MOTOROLA</b> MOBILE DEVICES	
ENGINEER:		BLOCK TITLE:	
LAST MODIFIED BY: Thu Jun 05 15:25:34 2014		<b>xmcs</b>	
MOTOROLA CONFIDENTIAL RESTRICTED		PROJECT NAME	REV
THE DRAWING ON THIS PRINT AND INFORMATION THEREWITH ARE PROPRIETARY TO MOTOROLA AND SHALL NOT BE USED OR DISCUSSED IN WHOLE OR IN PART WITHOUT MOTOROLA'S CONSENT. © COPYRIGHT, MOTOROLA. THIS DOES NOT IMPLY PUBLICATION		<b>B</b> 84016326001_a.cpm	01
CAD FILE NAME:		PAGE 51 OF 77	

# XMCS: DSP

REF 6300-6399

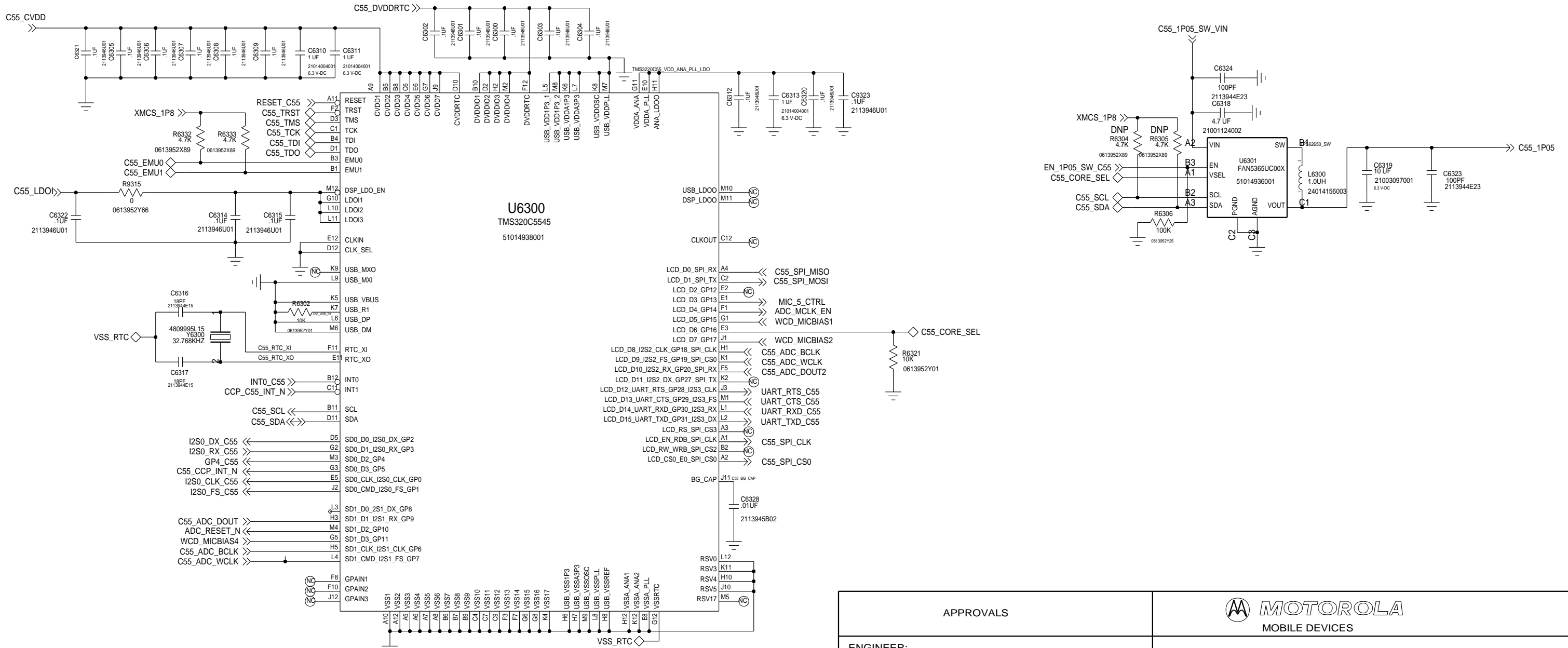

ANALOG GND LAYOUT NEEDS TO FOLLOW TI RECOMMENDATION

MOTOROLA MOBILITY CONFIDENTIAL RESTRICTED-MDB TRACKED TRACKEDANDBLOCKED

APPROVALS		 <b>MOTOROLA</b> MOBILE DEVICES	
ENGINEER:		BLOCK TITLE:	
LAST MODIFIED BY: Thu Jun 05 15:25:35 2014		<b>xmcs</b>	
MOTOROLA CONFIDENTIAL RESTRICTED <small>THE DRAWING ON THIS PRINT AND INFORMATION THEREWITH ARE PROPRIETARY TO MOTOROLA AND SHALL NOT BE USED OR DISCUSSED IN WHOLE OR IN PART WITHOUT MOTOROLA'S CONSENT.          © COPYRIGHT, MOTOROLA. THIS DOES NOT IMPLY PUBLICATION</small>		PROJECT NAME <b>B 84016326001_a.cpm</b>	REV <b>01</b>
		CAD FILE NAME:	
		PAGE 52 OF 77	

# XMCS: LOUD SPEAKER

REF 6400-6499

I2C ADDR: FOR WRITE 0X68  
I2C ADDR: FOR READ 0X69

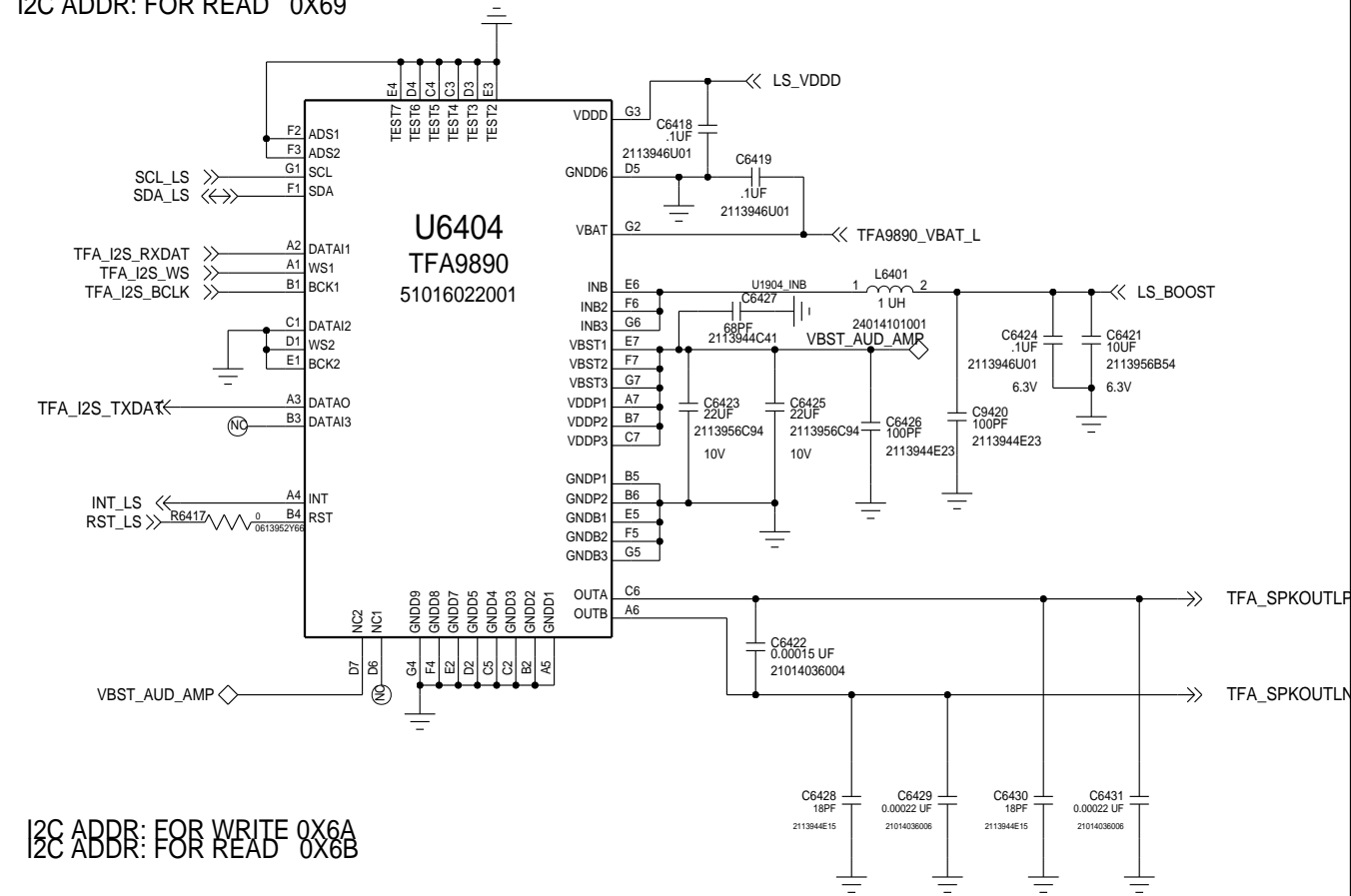

MOTOROLA MOBILITY CONFIDENTIAL RESTRICTED-MDB TRACKED TRACKEDANDBLOCKED

APPROVALS		 <b>MOTOROLA</b> MOBILE DEVICES	
ENGINEER:		BLOCK TITLE:	
LAST MODIFIED BY: Tue Aug 12 11:13:51 2014		<b>xmcs</b>	
MOTOROLA CONFIDENTIAL RESTRICTED <small>THE DRAWING ON THIS PRINT AND INFORMATION THEREWITH ARE PROPRIETARY TO MOTOROLA AND SHALL NOT BE USED OR DISCUSSED IN WHOLE OR IN PART WITHOUT MOTOROLA'S CONSENT.          © COPYRIGHT, MOTOROLA. THIS DOES NOT IMPLY PUBLICATION</small>		PROJECT NAME	REV
		B 84016326001_a.cpm	01
CAD FILE NAME:		PAGE 53 OF 77	

# USR: PORTS

REF: 800-999

## SUPPLIES

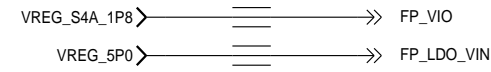

## INTERFACES

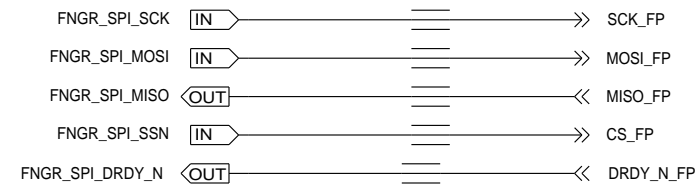

## GPIO - INPUT



## GPIO - OUTPUT

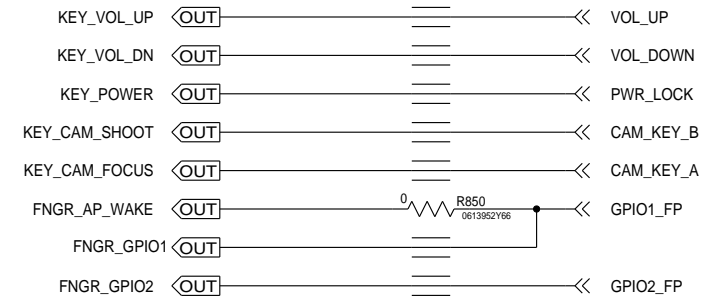

### APPROVALS

ENGINEER: NATE CONNELL

LAST MODIFIED BY: NATE CONNELL  
Thu Jun 05 15:25:27 2014

MOTOROLA CONFIDENTIAL RESTRICTED

THE DRAWING ON THIS PRINT AND INFORMATION  
THEREWITH ARE PROPRIETARY TO MOTOROLA AND  
SHALL NOT BE USED OR DISCUSSED IN WHOLE  
OR IN PART WITHOUT MOTOROLA'S CONSENT.  
© COPYRIGHT, MOTOROLA. THIS DOES  
NOT IMPLY PUBLICATION



BLOCK TITLE:

user\_input

PROJECT NAME  
B 84016326001\_a.cpm

REV  
01

CAD FILE NAME:

PAGE 54 OF 77

# USR: INPUT

REF: 800-899

## MECHANICAL KEYS

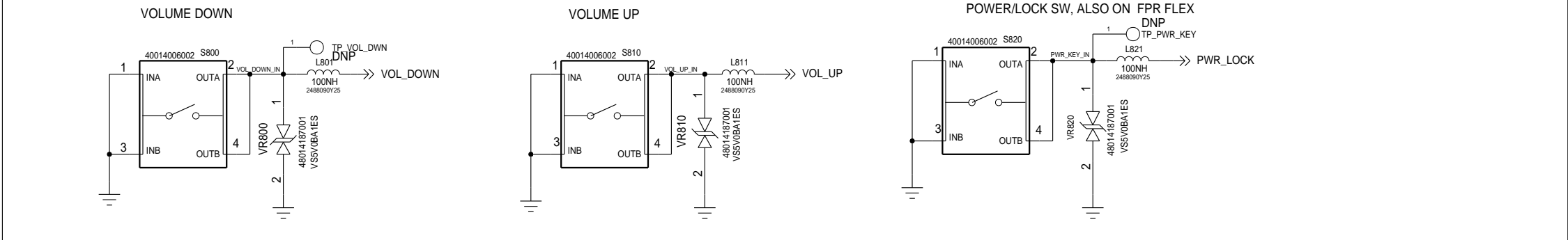

## FINGERPRINT SENSOR ZIF FLEX CONNECTOR

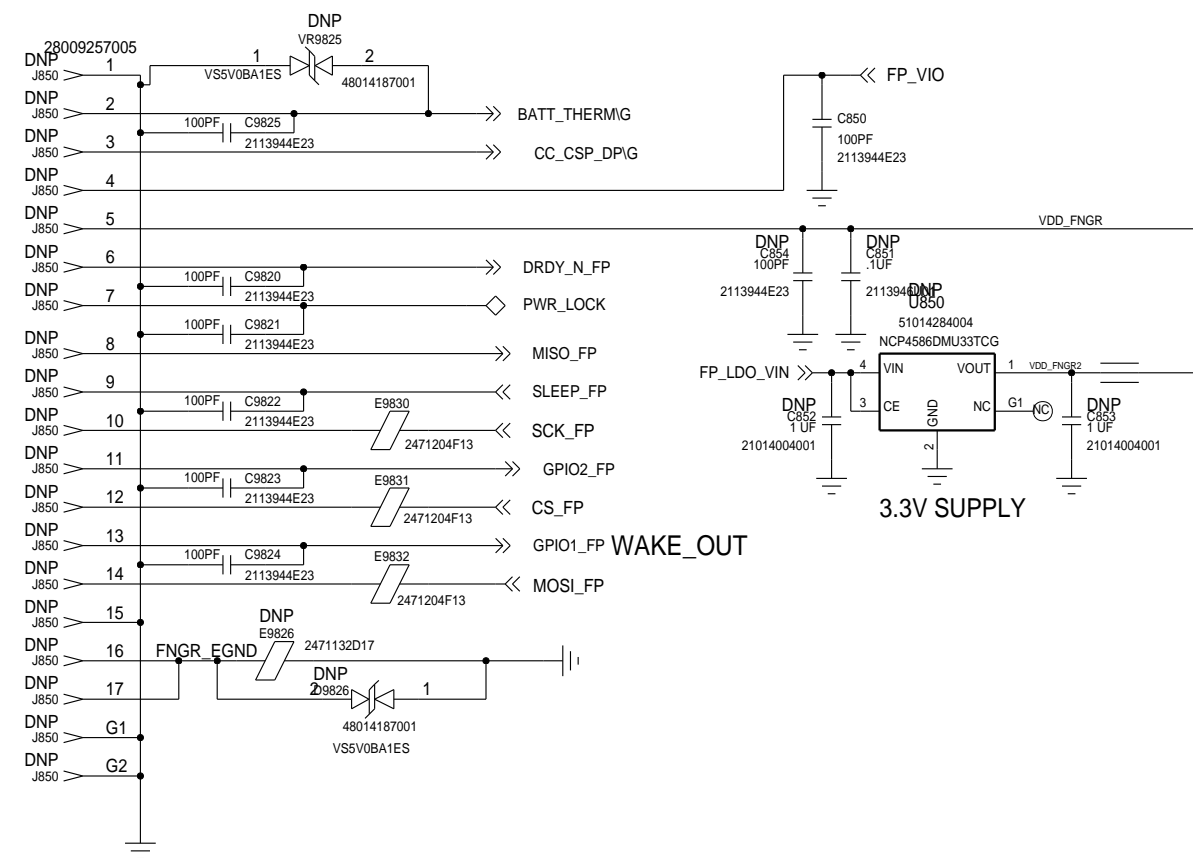

APPROVALS		<b>MOTOROLA</b> MOBILE DEVICES	
ENGINEER: NATE CONNELL		BLOCK TITLE:	
LAST MODIFIED BY: NATE CONNELL Thu Jun 05 15:25:28 2014		<b>user_input</b>	
MOTOROLA CONFIDENTIAL RESTRICTED <small>THE DRAWING ON THIS PRINT AND INFORMATION THEREWITH ARE PROPRIETARY TO MOTOROLA AND SHALL NOT BE USED OR DISCUSSED IN WHOLE OR IN PART WITHOUT MOTOROLA'S CONSENT. © COPYRIGHT, MOTOROLA. THIS DOES NOT IMPLY PUBLICATION</small>		PROJECT NAME	REV
		B 84016326001_a.cpm	01
CAD FILE NAME:		PAGE 55 OF 77	

# APQ: POWER

REF: 1000-1999

## SUPPLIES

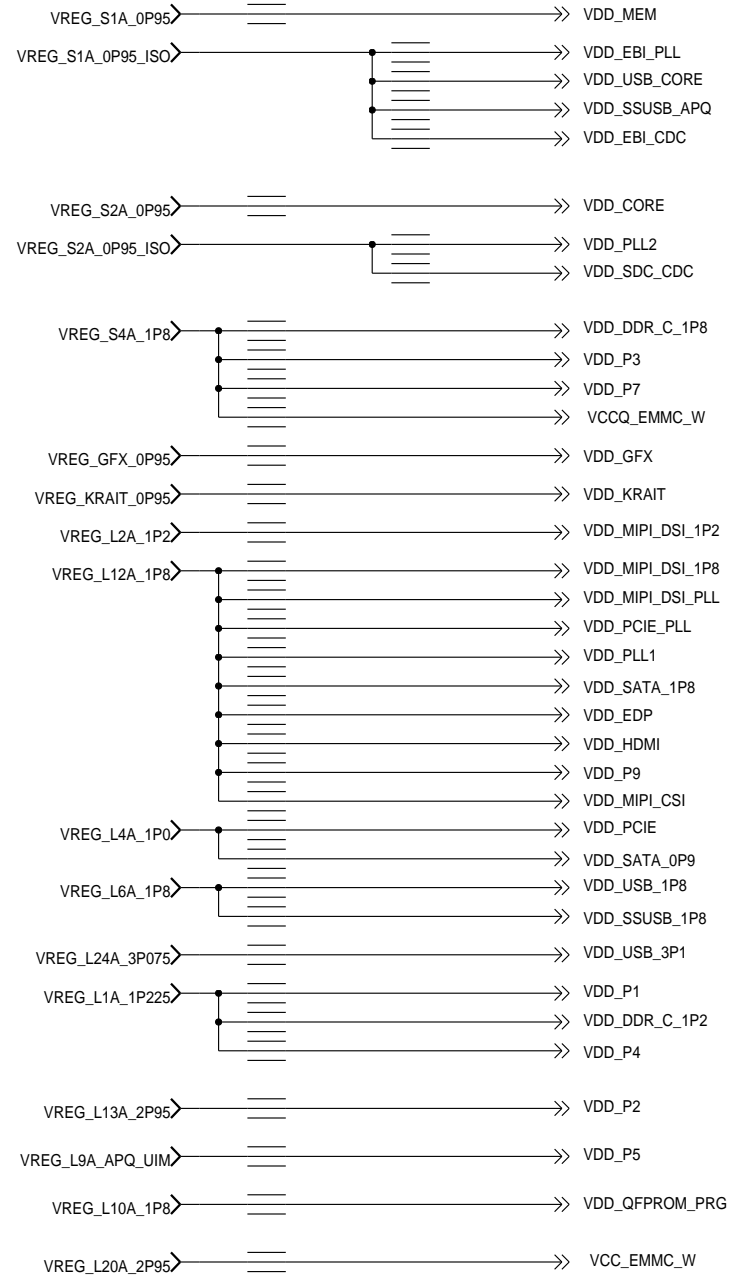

APPROVALS		<b>MOTOROLA</b> MOBILE DEVICES	
ENGINEER: NATE CONNELL		BLOCK TITLE:	
LAST MODIFIED BY: NATE CONNELL Thu Jun 05 15:25:17 2014		<b>ap_pmic</b>	
MOTOROLA CONFIDENTIAL RESTRICTED <small>THE DRAWING ON THIS PRINT AND INFORMATION THEREWITH ARE PROPRIETARY TO MOTOROLA AND SHALL NOT BE USED OR DISCUSSED IN WHOLE OR IN PART WITHOUT MOTOROLA'S CONSENT.          © COPYRIGHT, MOTOROLA. THIS DOES NOT IMPLY PUBLICATION</small>		PROJECT NAME <b>B 84016326001_a.cpm</b>	REV <b>01</b>
		CAD FILE NAME:	
		PAGE 56 OF 77	



# APQ: CTRL / GPIO

REF 1000-1099

FOR PORTABLE DESIGNS RENAME ETM\_GPIO BUS TO GPIO BUS

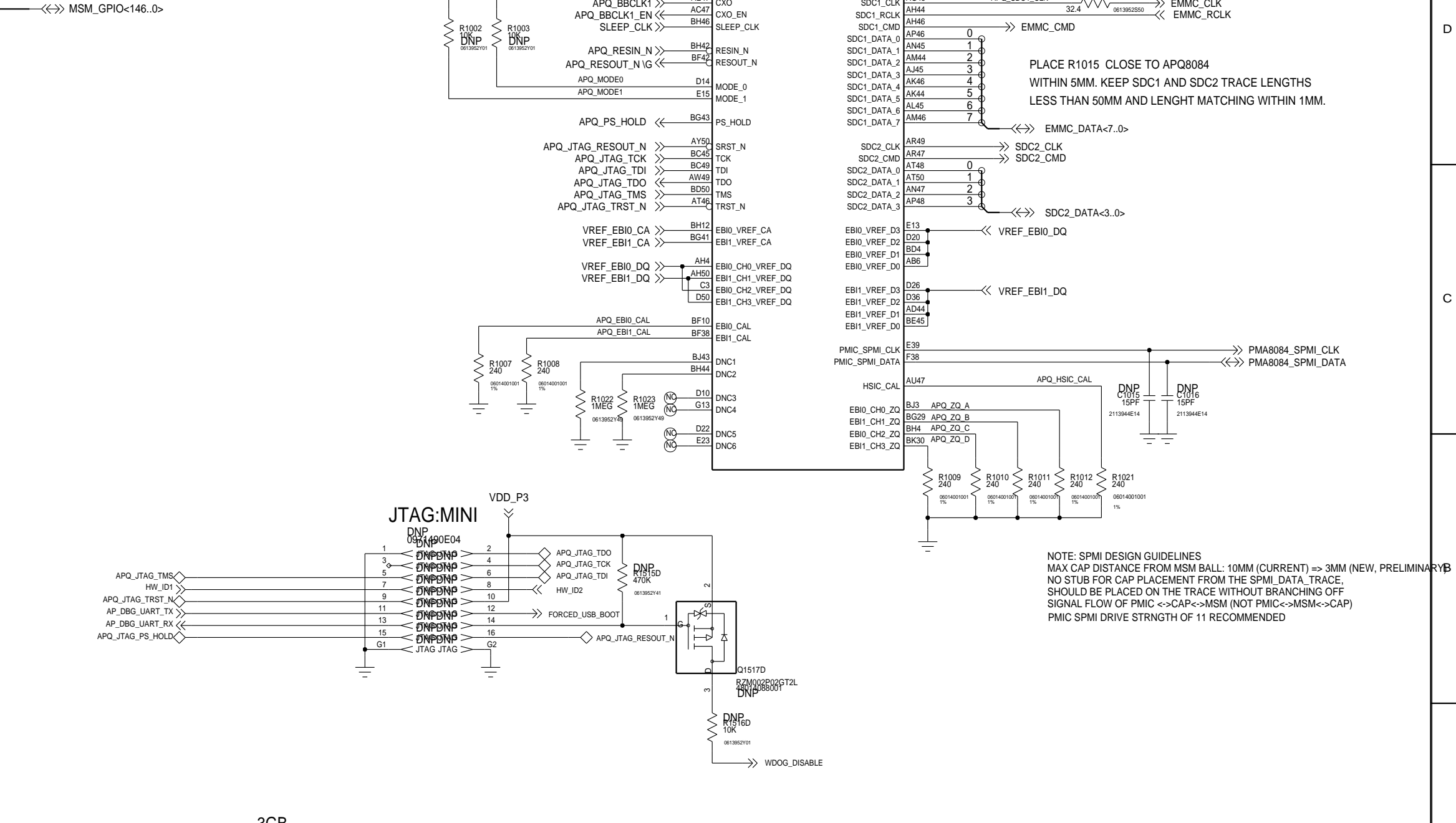
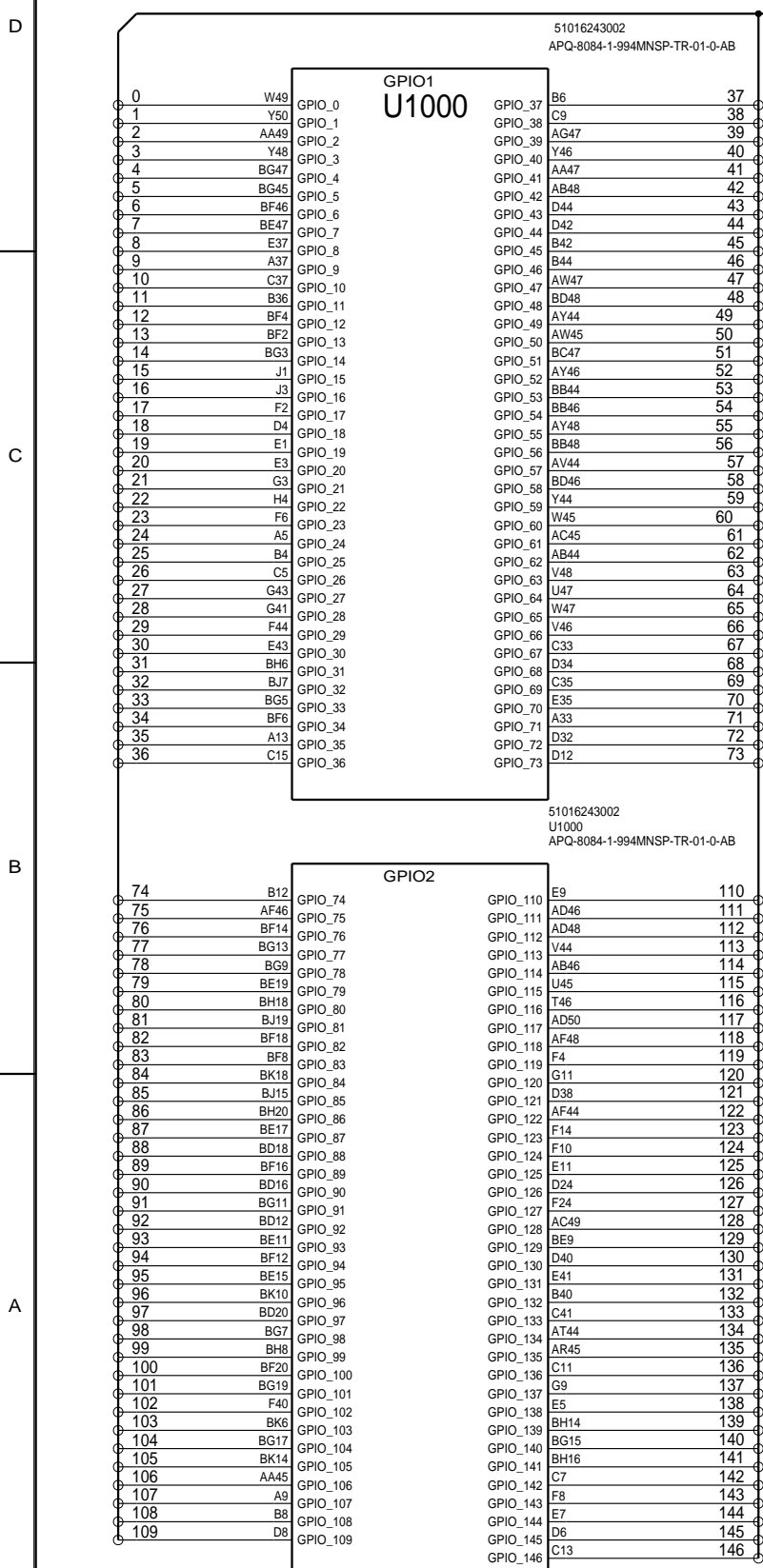

NOTE: SPMI DESIGN GUIDELINES  
 MAX CAP DISTANCE FROM MSM BALL: 10MM (CURRENT) => 3MM (NEW, PRELIMINARY)  
 NO STUB FOR CAP PLACEMENT FROM THE SPMI\_DATA TRACE,  
 SHOULD BE PLACED ON THE TRACE WITHOUT BRANCHING OFF  
 SIGNAL FLOW OF PMIC <->CAP<->MSM (NOT PMIC<->MSM<->CAP)  
 PMIC SPMI DRIVE STRNGTH OF 11 RECOMMENDED

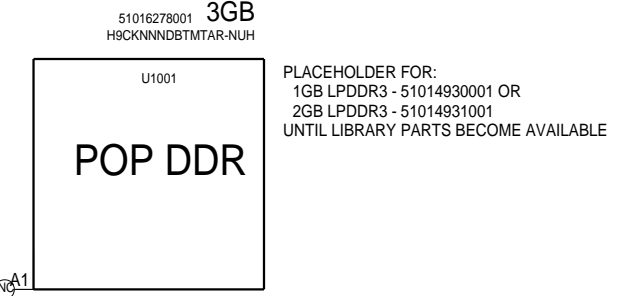

MOTOROLA MOBILITY CONFIDENTIAL RESTRICTED-MDB TRACKED TRACKEDANDBLOCKED					
<b>APPROVALS</b>  <b>ENGINEER:</b>  <b>LAST MODIFIED BY:</b> Thu Jun 05 15:25:18 2014	<b>MOTOROLA</b> MOBILE DEVICES  <b>BLOCK TITLE:</b> <h2 style="font-size: 1.5em;">ap_pmic</h2>				
MOTOROLA CONFIDENTIAL RESTRICTED THE DRAWING ON THIS PRINT AND INFORMATION THEREWITH ARE PROPRIETARY TO MOTOROLA AND SHALL NOT BE USED OR DISCUSSED IN WHOLE OR IN PART WITHOUT MOTOROLA'S CONSENT. © COPYRIGHT, MOTOROLA. THIS DOES NOT IMPLY PUBLICATION	<table border="1" style="width: 100%;"> <tr> <td style="width: 70%;"><b>PROJECT NAME</b> 84016326001_a.cpm</td> <td style="width: 30%;"><b>REV</b> 01</td> </tr> <tr> <td colspan="2"><b>CAD FILE NAME:</b></td> </tr> </table>	<b>PROJECT NAME</b> 84016326001_a.cpm	<b>REV</b> 01	<b>CAD FILE NAME:</b>	
<b>PROJECT NAME</b> 84016326001_a.cpm	<b>REV</b> 01				
<b>CAD FILE NAME:</b>					
PAGE 57 OF 77					

BASED ON 80-NA437-41 REV. G

# APQ: MIPI/USB/PCIE

REF 1030-1039

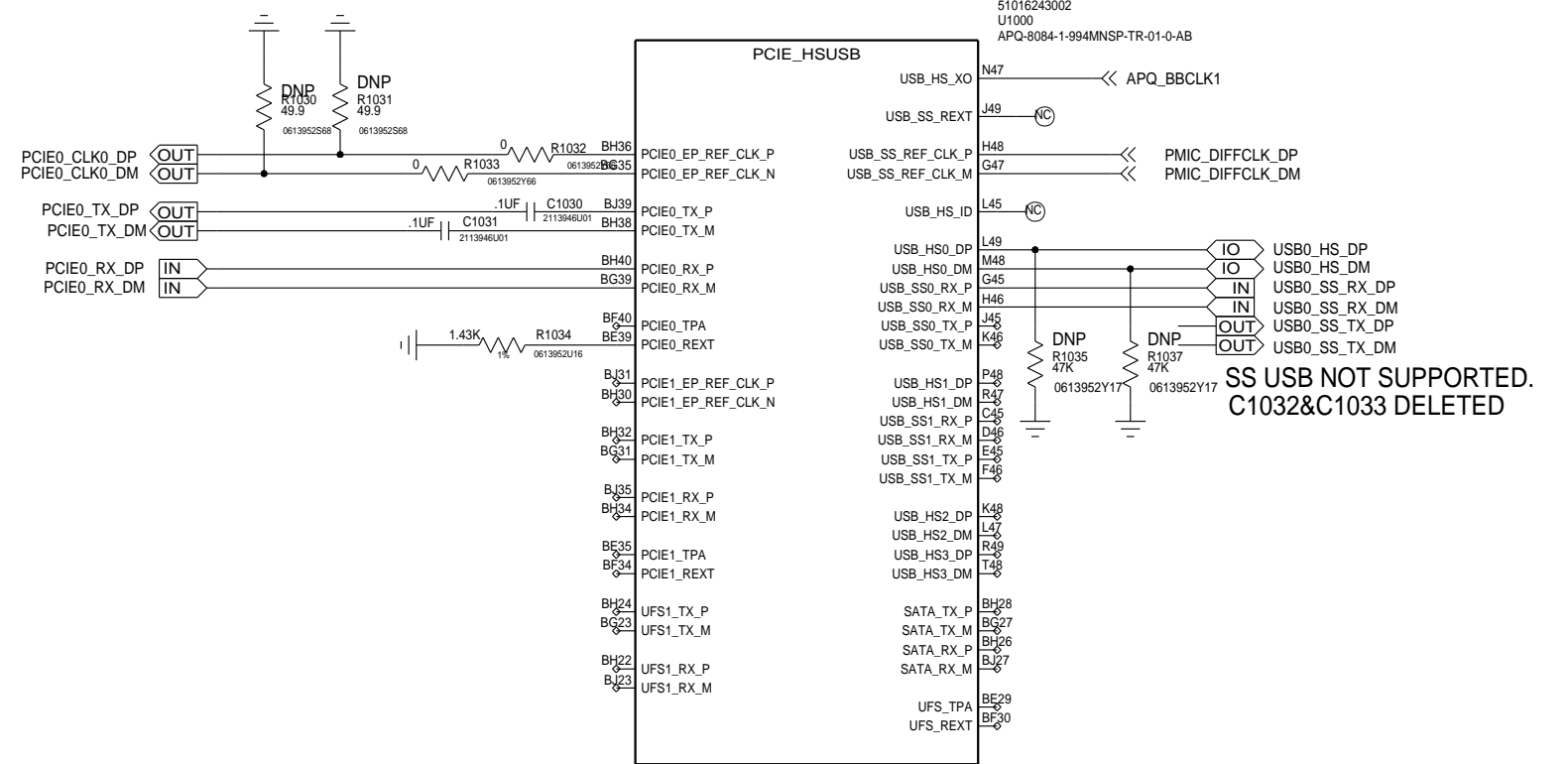
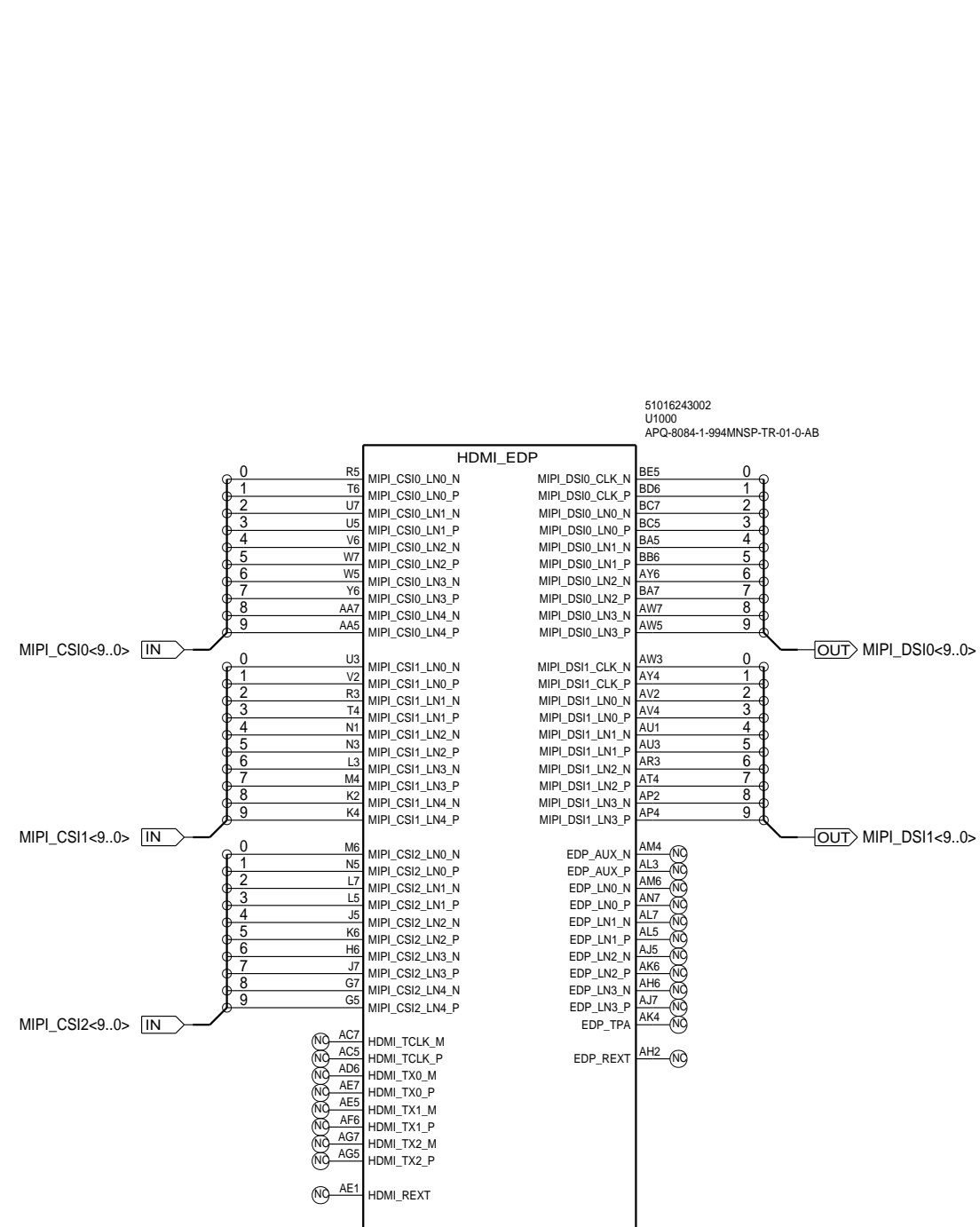

BASED ON 80-NA437-41 REV. G

MOTOROLA MOBILITY CONFIDENTIAL RESTRICTED-MDB TRACKED TRACKEDANDBLOCKED

APPROVALS			
ENGINEER:		BLOCK TITLE:	
LAST MODIFIED BY: Thu Jun 05 15:25:19 2014		<b>ap_pmic</b>	
MOTOROLA CONFIDENTIAL RESTRICTED THE DRAWING ON THIS PRINT AND INFORMATION THEREWITH ARE PROPRIETARY TO MOTOROLA AND SHALL NOT BE USED OR DISCUSSED IN WHOLE OR IN PART WITHOUT MOTOROLA'S CONSENT. © COPYRIGHT, MOTOROLA. THIS DOES NOT IMPLY PUBLICATION		PROJECT NAME <b>B 84016326001_a.cpm</b>	REV <b>01</b>
		CAD FILE NAME:	
		PAGE 58 OF 77	

# APQ: POWER 1

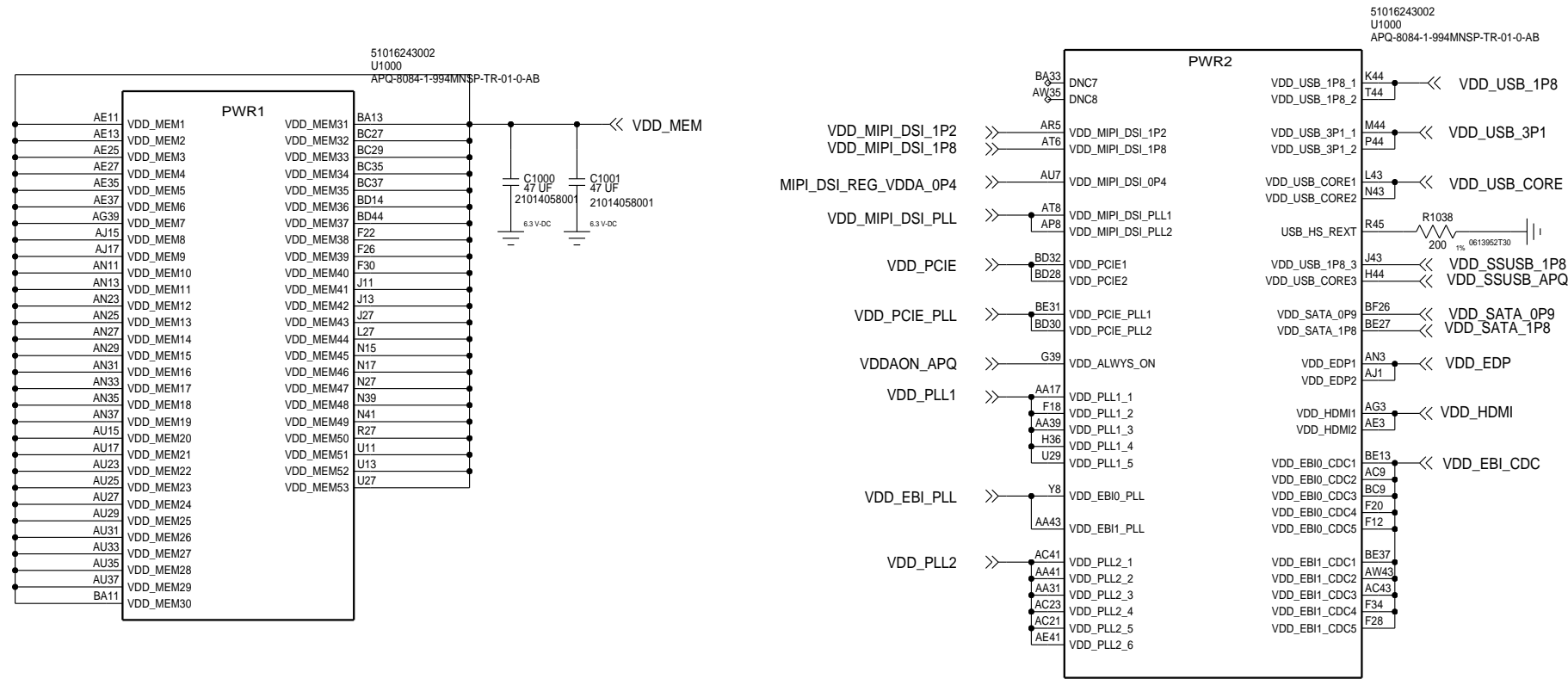

MOTOROLA MOBILITY CONFIDENTIAL RESTRICTED-MDB TRACKED TRACKEDANDBLOCKED

APPROVALS		 <b>MOTOROLA</b> MOBILE DEVICES	
ENGINEER: MOTOROLA		BLOCK TITLE:	
LAST MODIFIED BY: MOTOROLA Thu Jun 05 15:25:19 2014		ap_pmic	
MOTOROLA CONFIDENTIAL RESTRICTED <small>THE DRAWING ON THIS PRINT AND INFORMATION THEREWITH ARE PROPRIETARY TO MOTOROLA AND SHALL NOT BE USED OR DISCUSSED IN WHOLE OR IN PART WITHOUT MOTOROLA'S CONSENT.          © COPYRIGHT, MOTOROLA. THIS DOES NOT IMPLY PUBLICATION</small>		PROJECT NAME	REV
		B 84016326001_a.cpm	01
CAD FILE NAME:		PAGE 59 OF 77	

# APQ: POWER 2

51016243002  
U1000  
APQ-8084-1-994MNSP-TR-01-0-AB

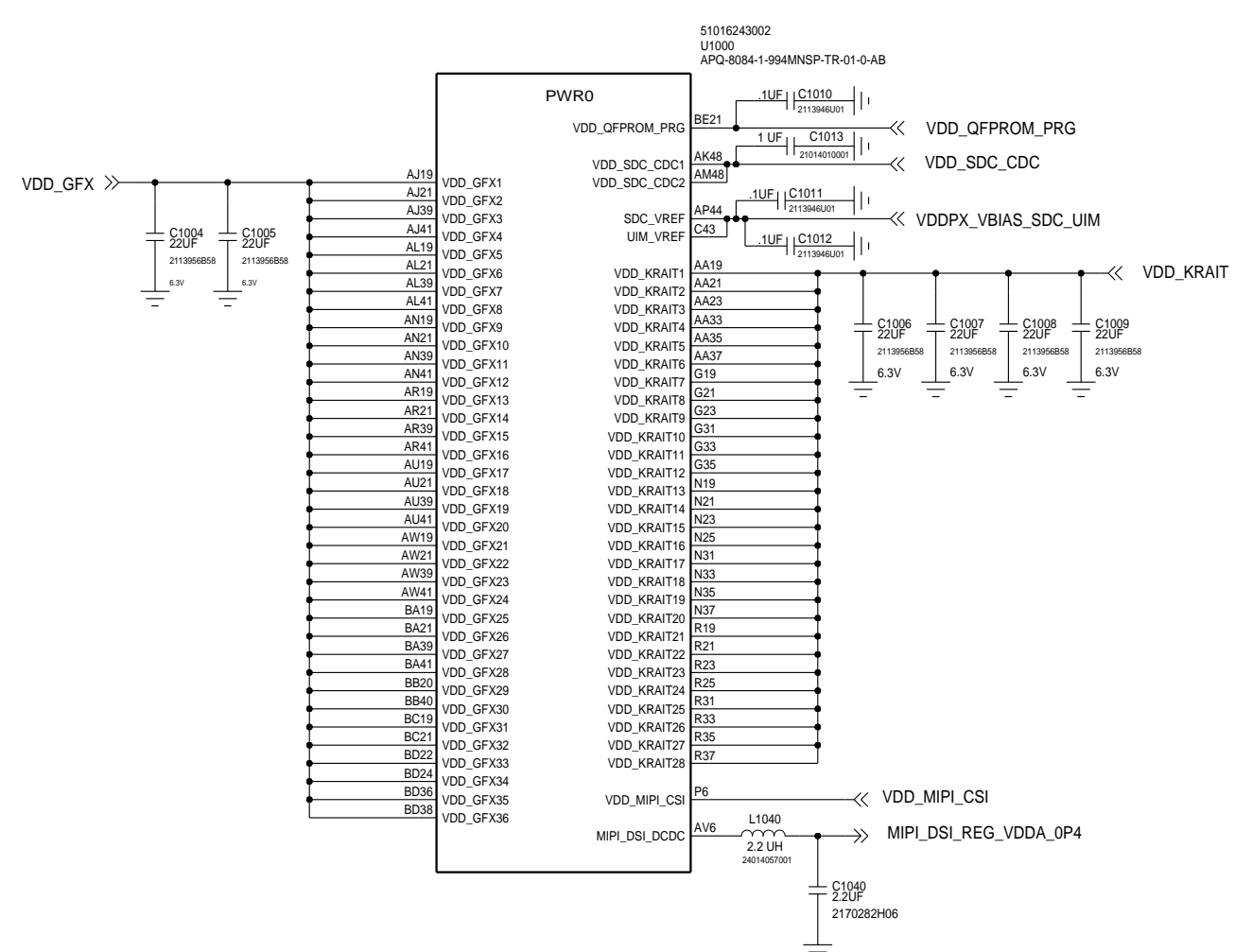
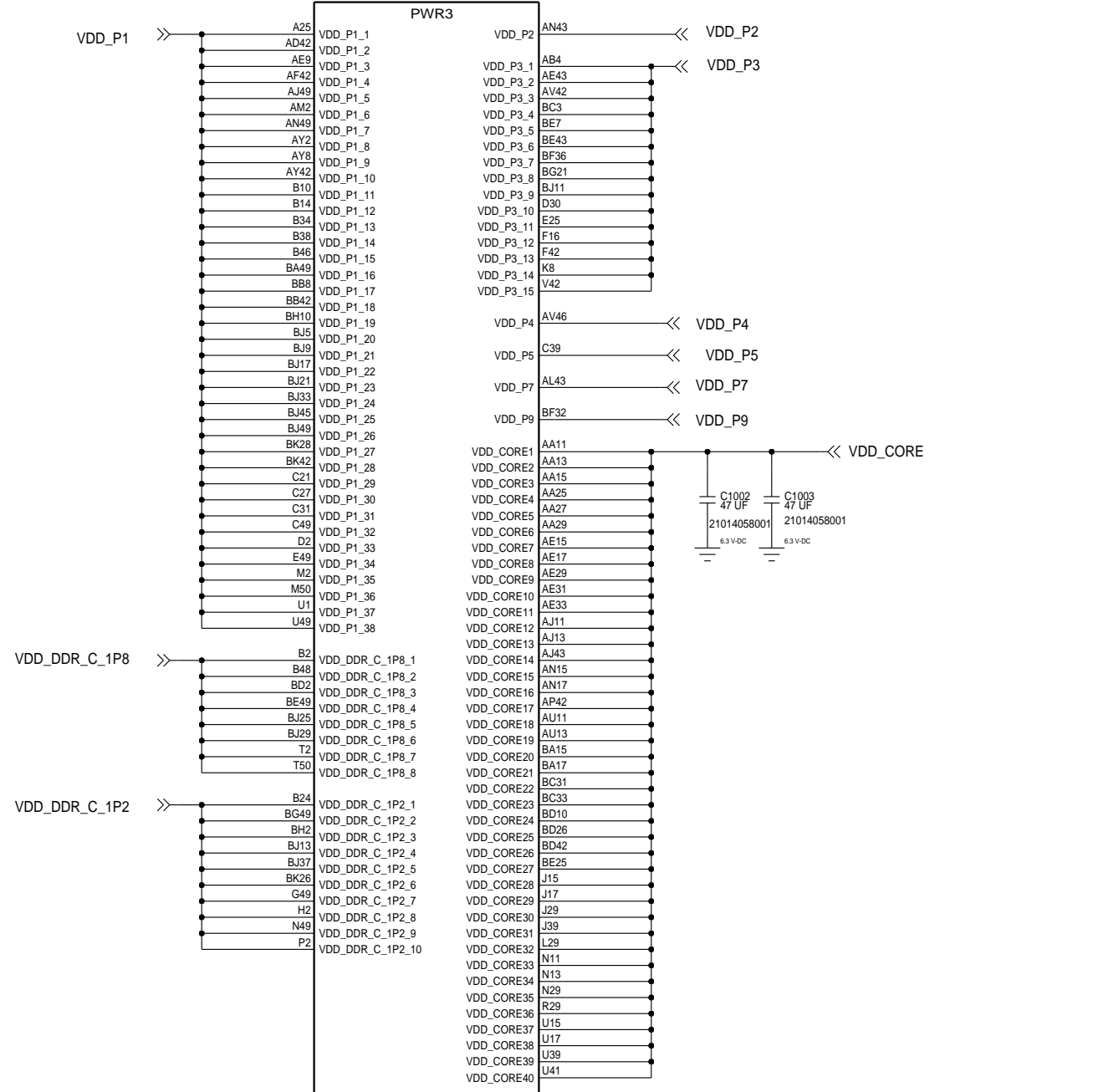

APPROVALS		<b>MOTOROLA</b> MOBILE DEVICES	
ENGINEER: MOTOROLA		BLOCK TITLE:	
LAST MODIFIED BY: MOTOROLA Thu Jun 05 15:25:20 2014		<b>ap_pmic</b>	
MOTOROLA CONFIDENTIAL RESTRICTED <small>THE DRAWING ON THIS PRINT AND INFORMATION THEREWITH ARE PROPRIETARY TO MOTOROLA AND SHALL NOT BE USED OR DISCUSSED IN WHOLE OR IN PART WITHOUT MOTOROLA'S CONSENT. © COPYRIGHT, MOTOROLA. THIS DOES NOT IMPLY PUBLICATION</small>		PROJECT NAME	REV
		B 84016326001_a.cpm	01
CAD FILE NAME:		PAGE 60 OF 77	

# APQ: BYPASS CAPS

REF 1400-1499

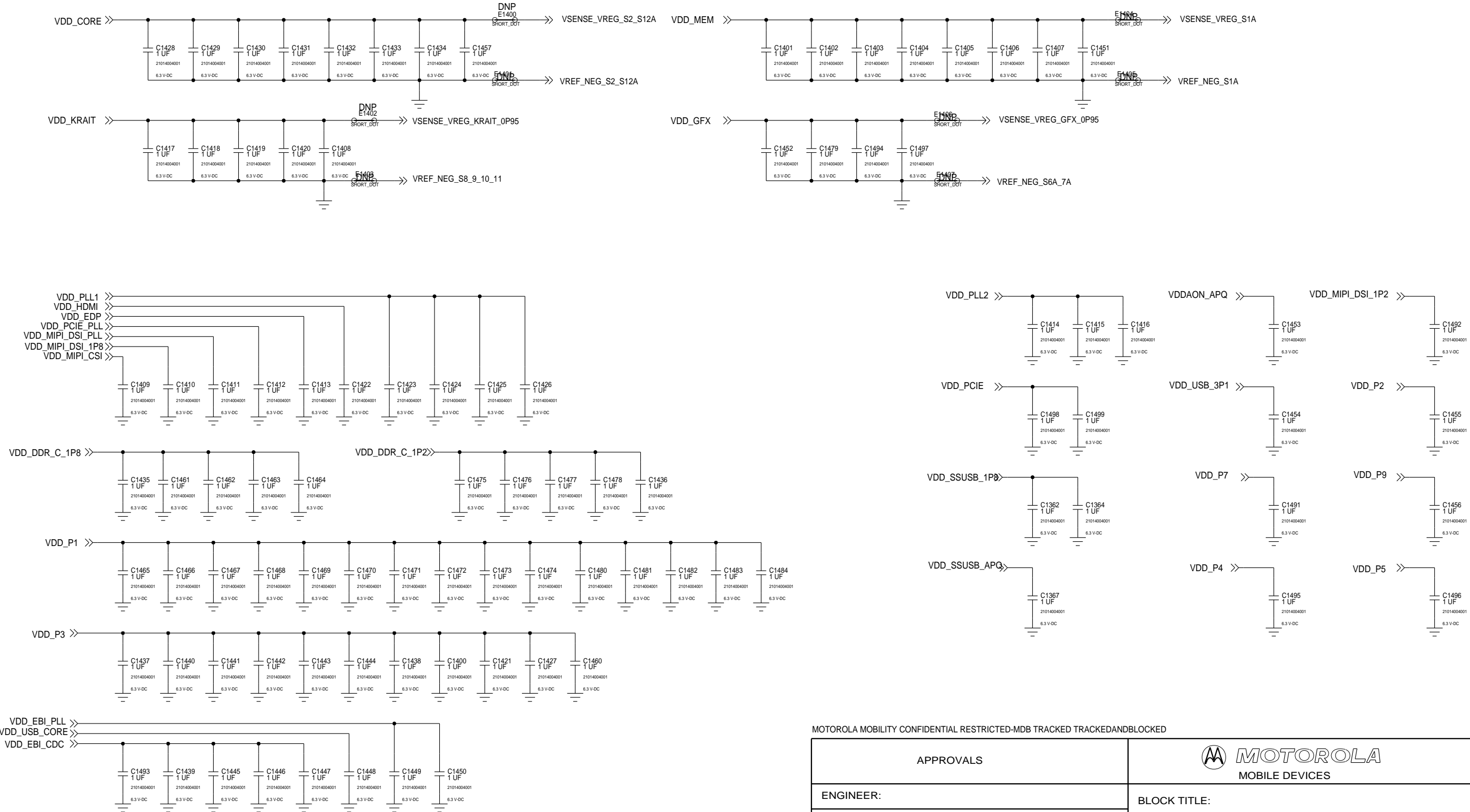

MOTOROLA MOBILITY CONFIDENTIAL RESTRICTED-MDB TRACKED TRACKEDANDBLOCKED

APPROVALS		 MOBILE DEVICES	
ENGINEER:		BLOCK TITLE:	
LAST MODIFIED BY: Thu Jun 05 15:25:21 2014		ap_pmic	
MOTOROLA CONFIDENTIAL RESTRICTED THE DRAWING ON THIS PRINT AND INFORMATION THEREWITH ARE PROPRIETARY TO MOTOROLA AND SHALL NOT BE USED OR DISCUSSED IN WHOLE OR IN PART WITHOUT MOTOROLA'S CONSENT. © COPYRIGHT, MOTOROLA. THIS DOES NOT IMPLY PUBLICATION		PROJECT NAME	REV
		B 84016326001_a.cpm	01
CAD FILE NAME:		PAGE 61 OF 77	

# APQ: GND/NC

51016243002  
U1000  
APQ-8084-1-994MNSP-TR-01-0-AB

51016243002  
U1000  
APQ-8084-1-994MNSP-TR-01-0-AB

51016243002  
U1000  
APQ-8084-1-994MNSP-TR-01-0-AB

51016243002  
U1000  
APQ-8084-1-994MNSP-TR-01-0-AB

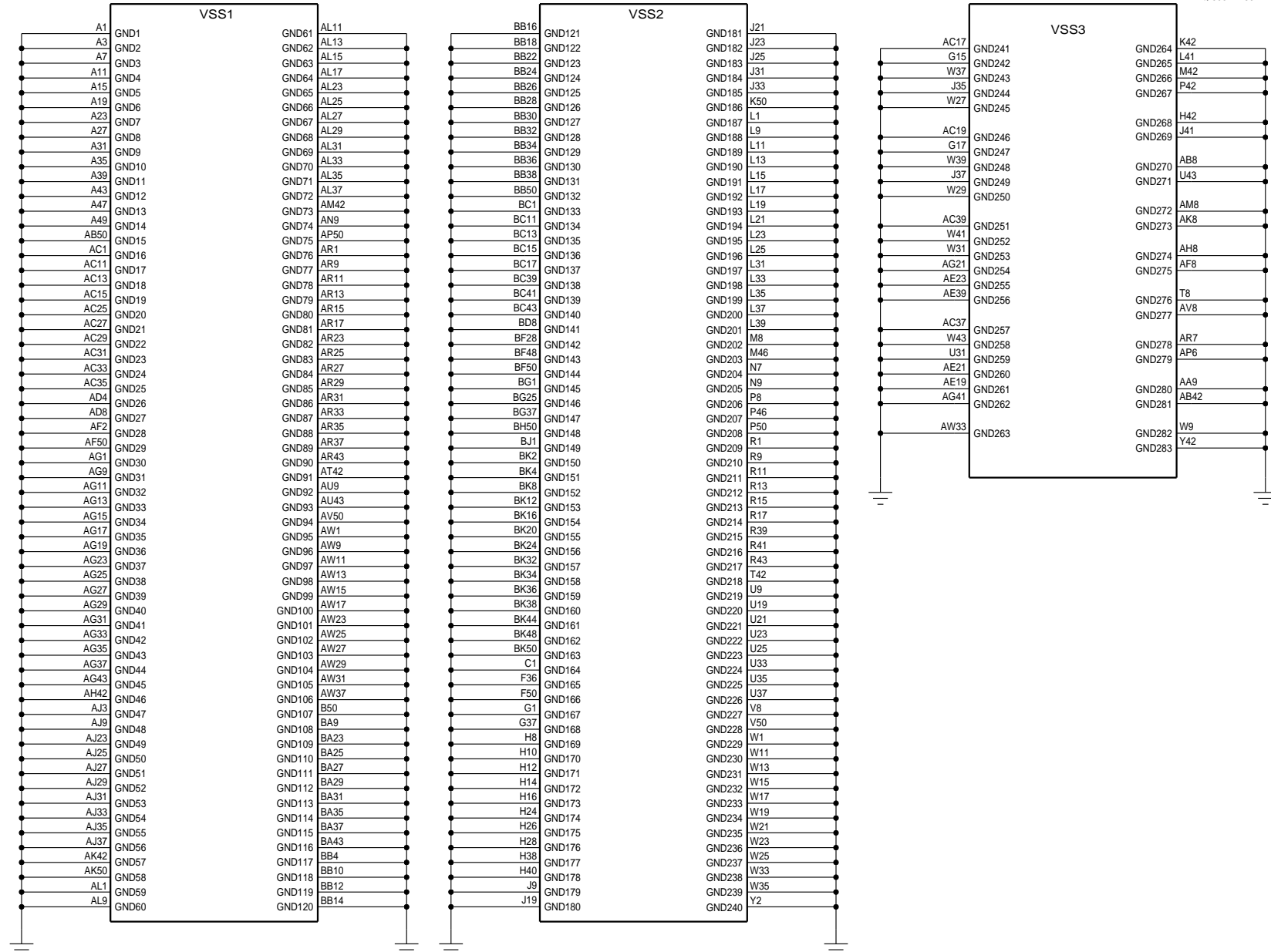

MOTOROLA MOBILITY CONFIDENTIAL RESTRICTED-MDB TRACKED TRACKEDANDBLOCKED

APPROVALS		 <b>MOTOROLA</b> MOBILE DEVICES	
ENGINEER:		BLOCK TITLE:	
LAST MODIFIED BY: Thu Jun 05 15:25:21 2014		ap_pmic	
MOTOROLA CONFIDENTIAL RESTRICTED		PROJECT NAME	REV
<small>THE DRAWING ON THIS PRINT AND INFORMATION THEREWITH ARE PROPRIETARY TO MOTOROLA AND SHALL NOT BE USED OR DISCUSSED IN WHOLE OR IN PART WITHOUT MOTOROLA'S CONSENT. © COPYRIGHT, MOTOROLA. THIS DOES NOT IMPLY PUBLICATION</small>		B 84016326001_a.cpm	01
		CAD FILE NAME:	
		PAGE 62 OF 77	

BASED ON 80-NA437-41 REV. G

# APQ: GPIO MAP

PURPLE=MOT CUSTOM  
CYAN=QCOM REFERENCE

MSM\_GPIO<146..0><=>

PMA8084\_GPIO<22..1><=>

PM GPIO

PMA8084\_MPP<8..1><=>

PM MPP

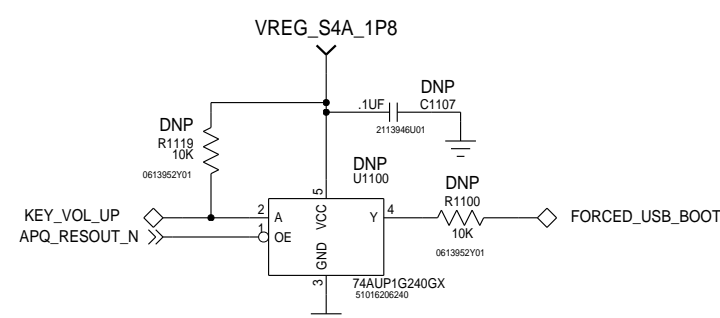
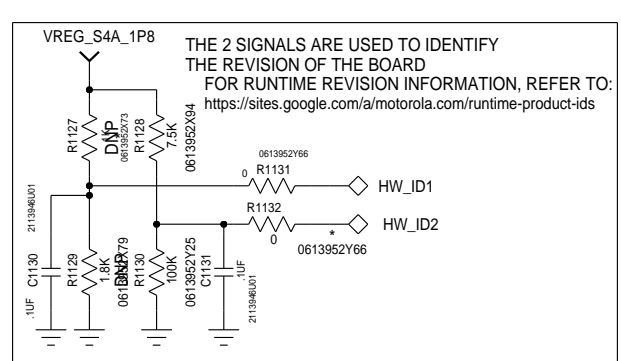
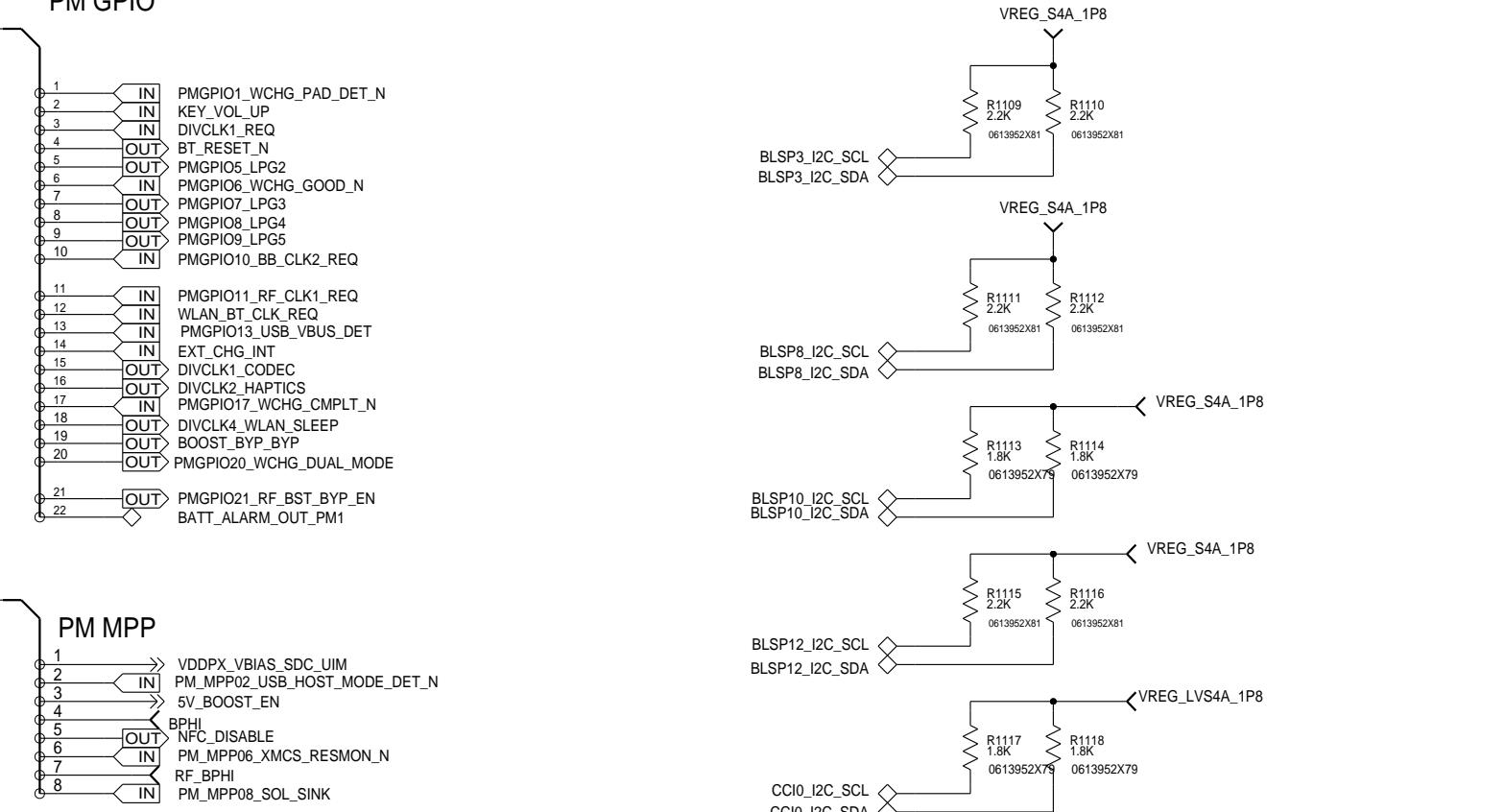
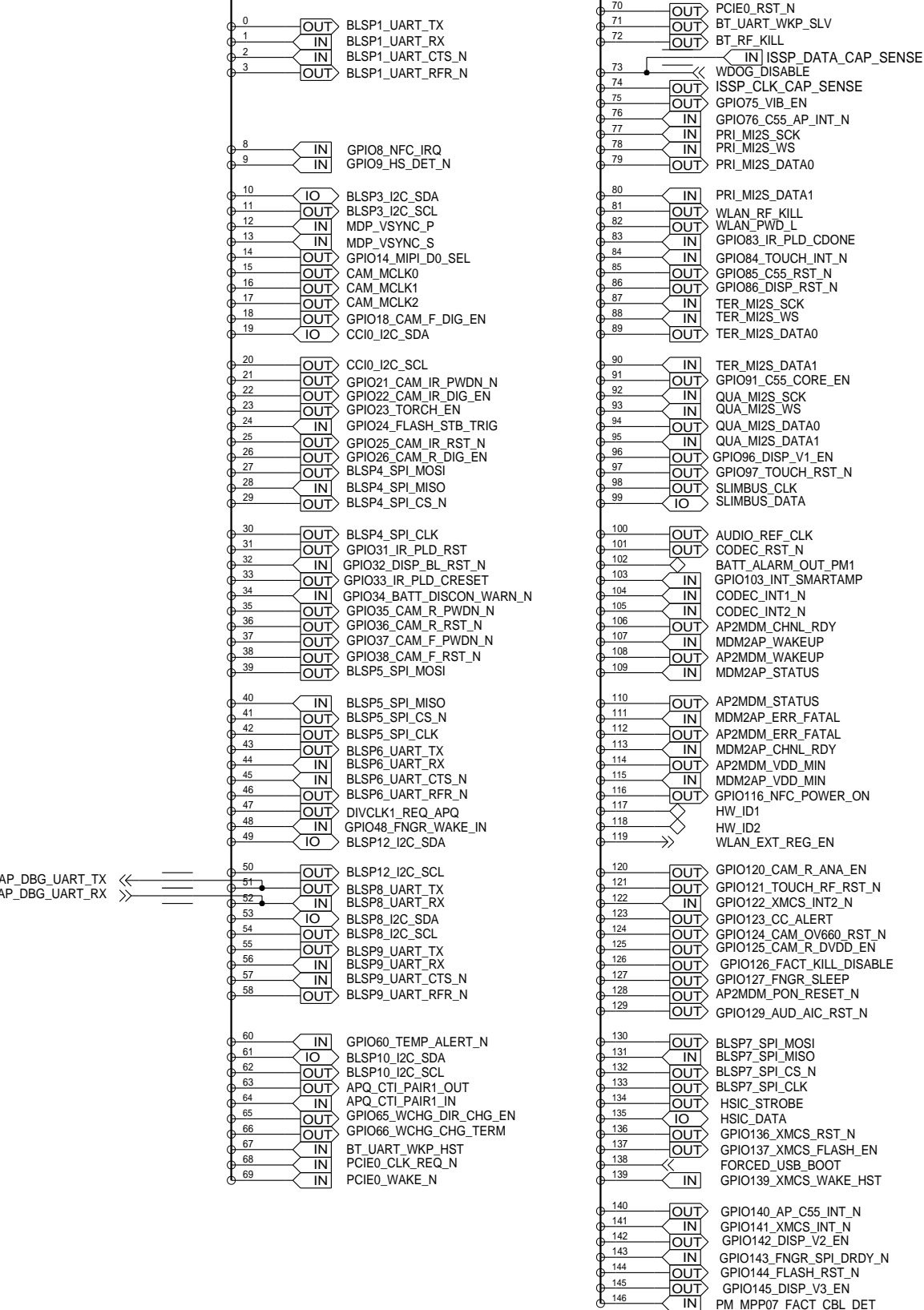

MOTOROLA MOBILITY CONFIDENTIAL RESTRICTED-MDB TRACKED TRACKEDANDBLOCKED

APPROVALS		 <b>MOTOROLA</b> MOBILE DEVICES	
ENGINEER:		BLOCK TITLE:	
LAST MODIFIED BY: <b>TIM MILLER</b> Fri Jul 11 09:59:19 2014		<b>ap_pmic</b>	
MOTOROLA CONFIDENTIAL RESTRICTED		PROJECT NAME	REV
THE DRAWING ON THIS PRINT AND INFORMATION THEREWITH ARE PROPRIETARY TO MOTOROLA AND SHALL NOT BE USED OR DISCUSSED IN WHOLE OR IN PART WITHOUT MOTOROLA'S CONSENT. © COPYRIGHT, MOTOROLA. THIS DOES NOT IMPLY PUBLICATION		<b>B</b> 84016326001_a.cpm	01
CAD FILE NAME:		PAGE 63 OF 77	





# PMA8084: POWER

REF: 2000-2999

## SUPPLIES

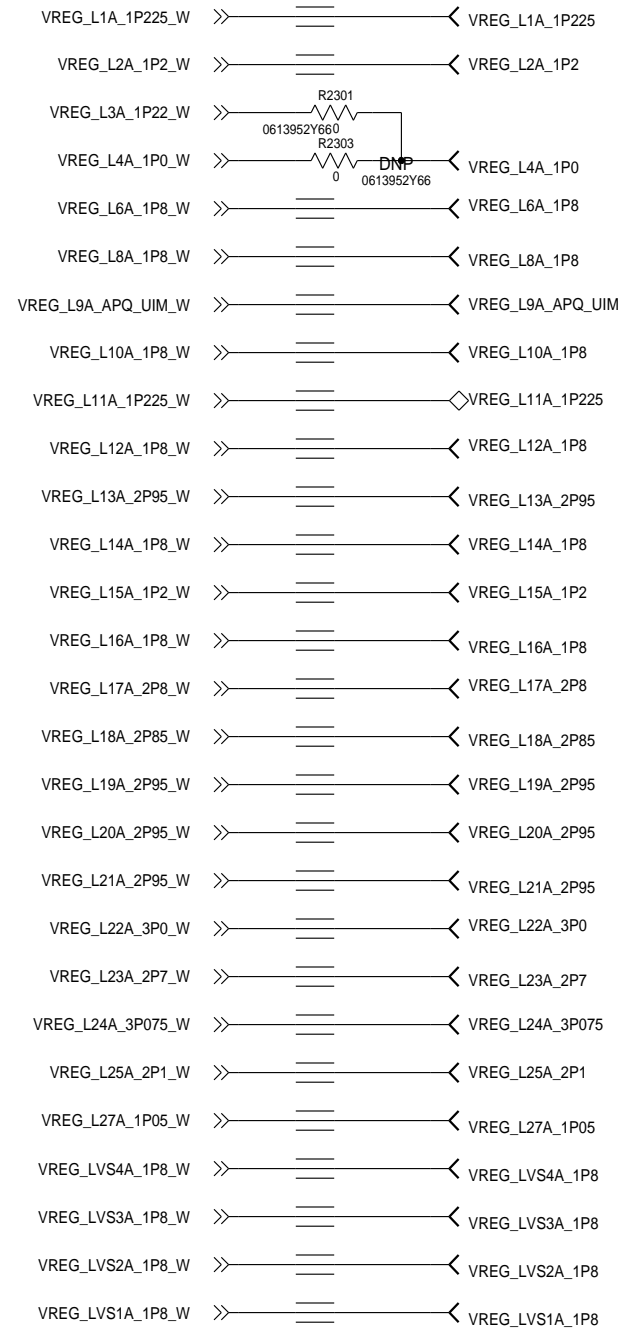
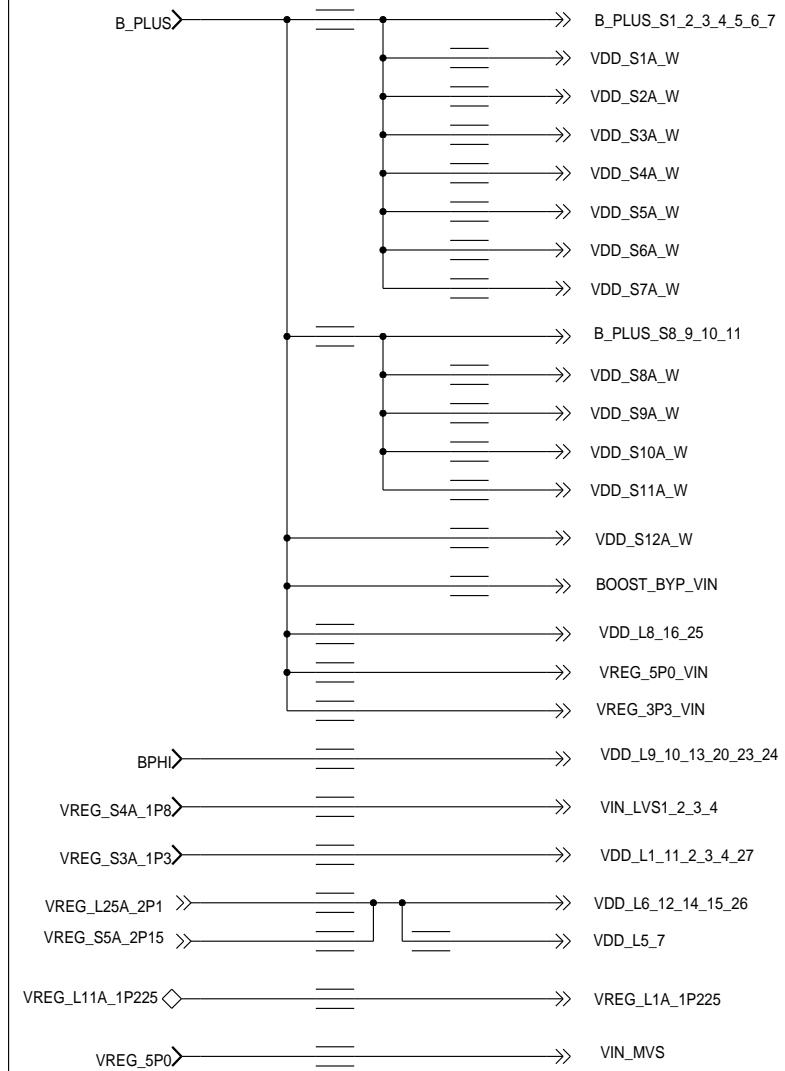

APPROVALS		<b>MOTOROLA</b> MOBILE DEVICES	
ENGINEER: NATE CONNELL		BLOCK TITLE:	
LAST MODIFIED BY: NATE CONNELL Thu Jun 05 15:25:23 2014		<b>ap_pmic</b>	
MOTOROLA CONFIDENTIAL RESTRICTED <small>THE DRAWING ON THIS PRINT AND INFORMATION THEREWITH ARE PROPRIETARY TO MOTOROLA AND SHALL NOT BE USED OR DISCUSSED IN WHOLE OR IN PART WITHOUT MOTOROLA'S CONSENT.          © COPYRIGHT, MOTOROLA. THIS DOES NOT IMPLY PUBLICATION</small>		PROJECT NAME <b>B 84016326001_a.cpm</b>	REV <b>01</b>
		CAD FILE NAME:	
		PAGE 65 OF 77	

# PMA8084: CLK/CTRL/GPIO

## REF 2000-2099

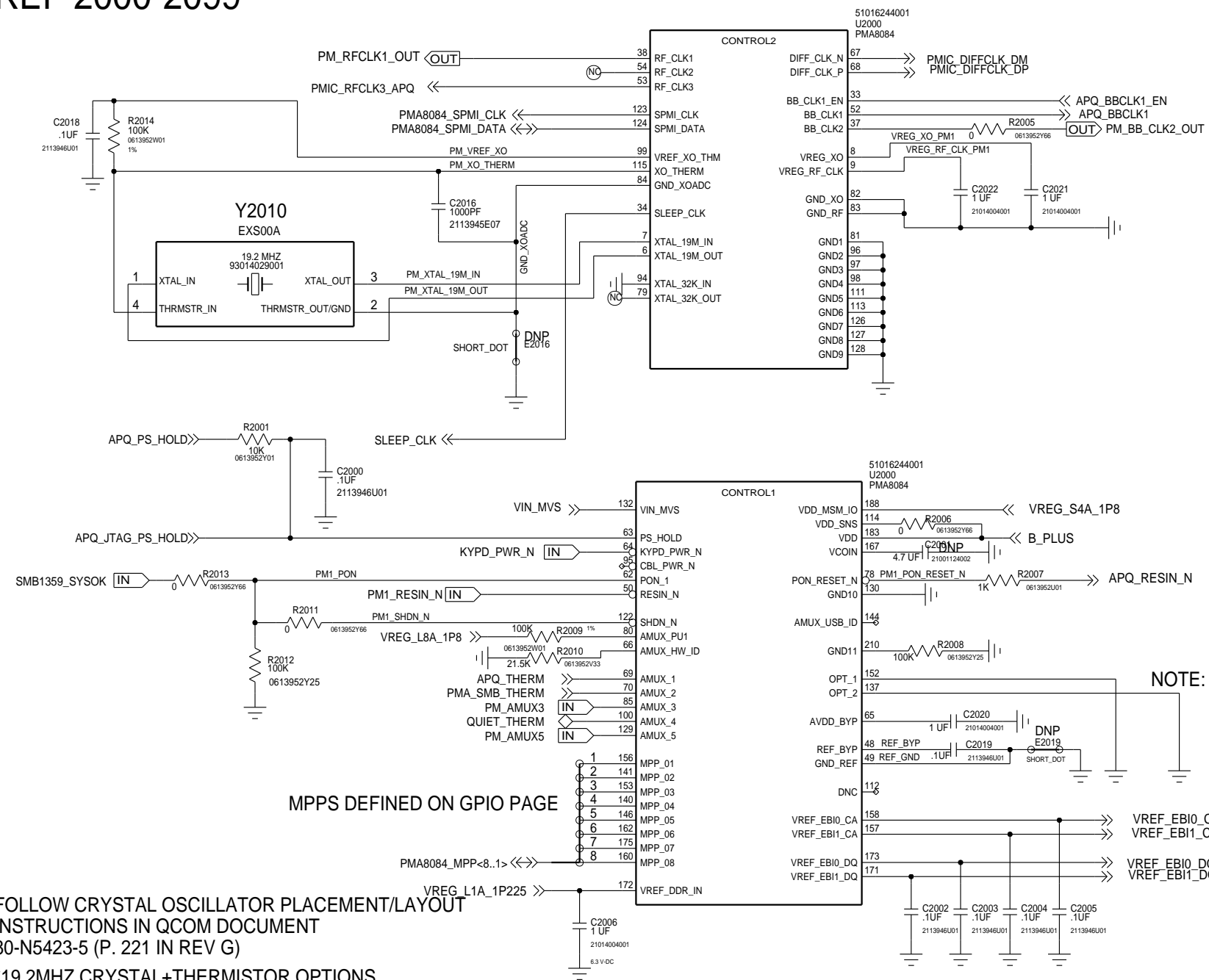

MPPS DEFINED ON GPIO PAGE

NOTE: OPT\_1&OPT\_2 = GND FOR APQ8084

FOLLOW CRYSTAL OSCILLATOR PLACEMENT/LAYOUT INSTRUCTIONS IN QCOM DOCUMENT 80-N5423-5 (P. 221 IN REV G)

\*19.2MHZ CRYSTAL+THERMISTOR OPTIONS  
 PACKAGE PART NUMBER  
 2520 93014012001  
 2016 93014029001

PM GPIOs DEFINED ON MSM GPIO PAGE

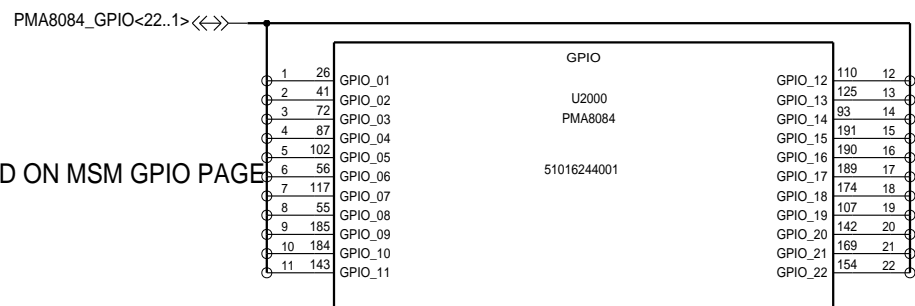

BASED ON 80-NA437-41 REV. G

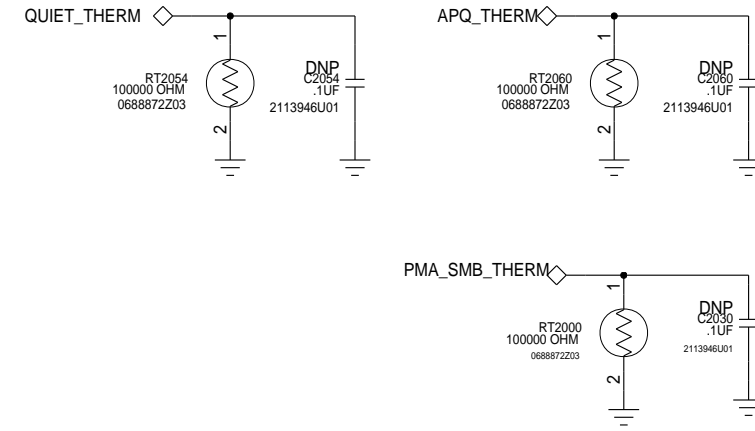

MOTOROLA MOBILITY CONFIDENTIAL RESTRICTED-MDB TRACKED TRACKEDANDBLOCKED

APPROVALS		 <b>MOTOROLA</b> MOBILE DEVICES	
ENGINEER:		BLOCK TITLE:	
LAST MODIFIED BY:		ap_pmic	
Thu Jun 05 15:25:24 2014		PROJECT NAME	
MOTOROLA CONFIDENTIAL RESTRICTED <small>THE DRAWING ON THIS PRINT AND INFORMATION THEREWITH ARE PROPRIETARY TO MOTOROLA AND SHALL NOT BE USED OR DISCUSSED IN WHOLE OR IN PART WITHOUT MOTOROLA'S CONSENT.</small> © COPYRIGHT, MOTOROLA. THIS DOES NOT IMPLY PUBLICATION		B 84016326001_a.cpm	REV 01
CAD FILE NAME:		PAGE 66 OF 77	

# PMA8084: SMPS

## REF 2200-2299

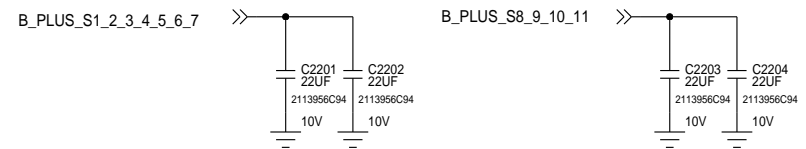
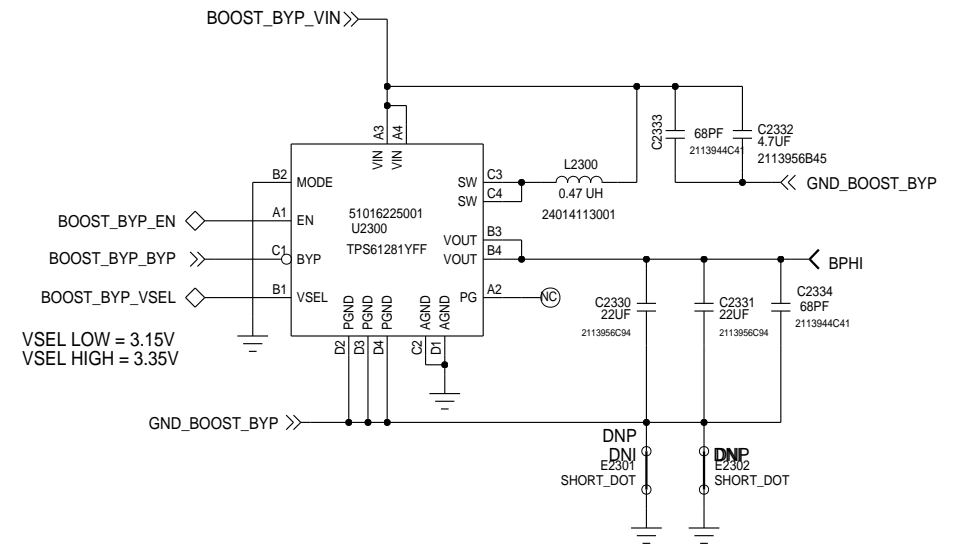
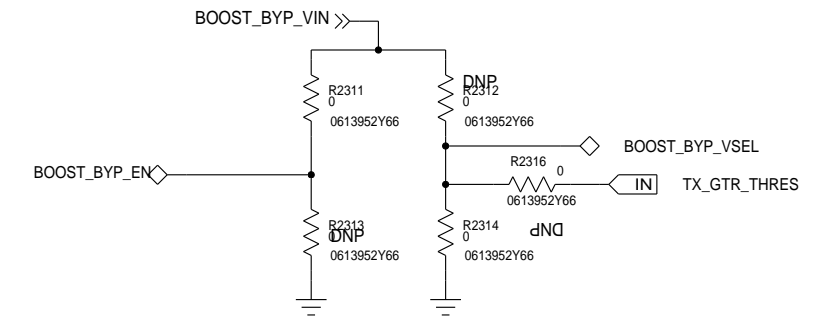
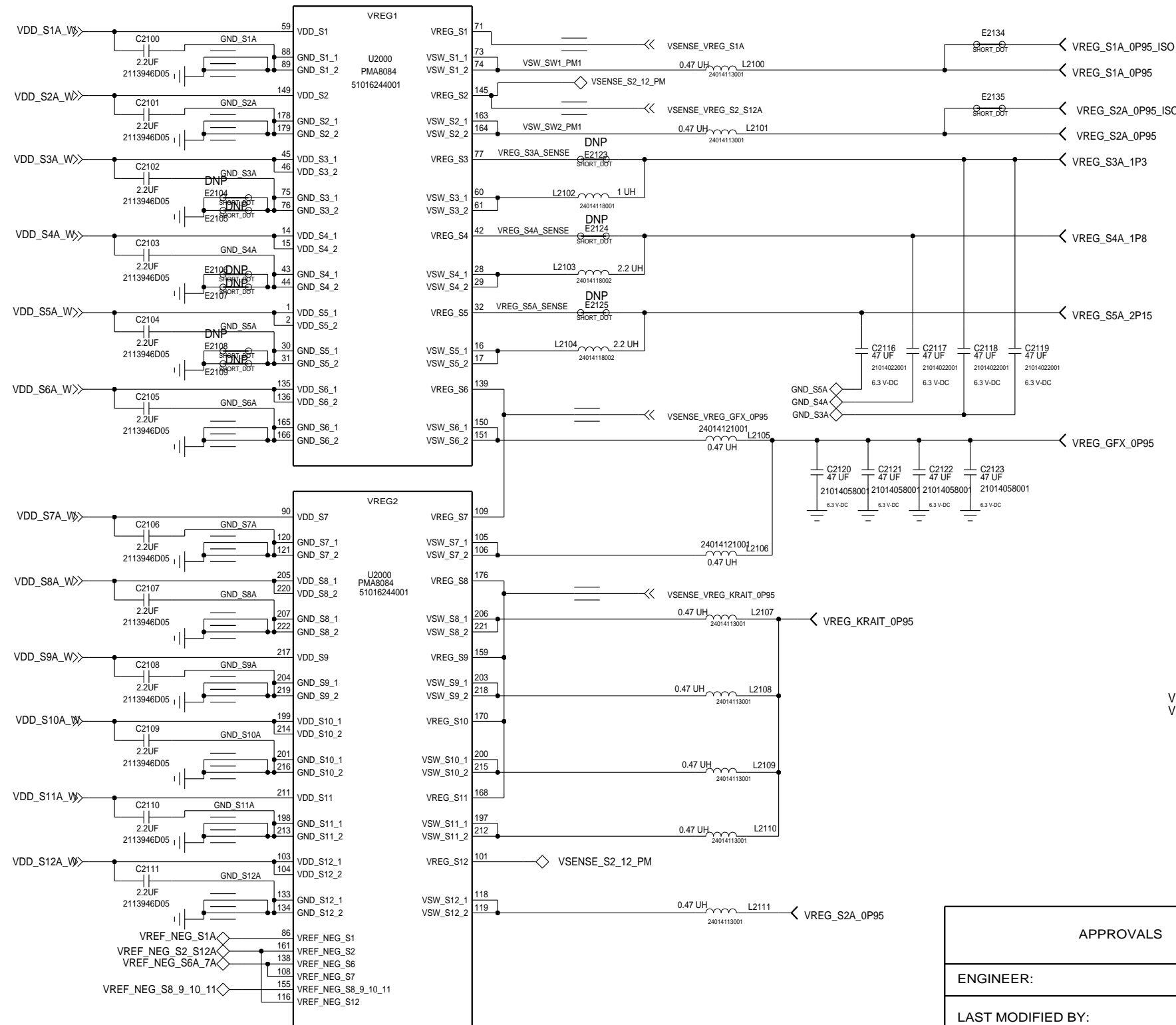

APPROVALS			
ENGINEER:	BLOCK TITLE:		
LAST MODIFIED BY:	ap_pmic		
MOTOROLA CONFIDENTIAL RESTRICTED THE DRAWING ON THIS PRINT AND INFORMATION THERWITH ARE PROPRIETARY TO MOTOROLA AND SHALL NOT BE USED OR DISCUSSED IN WHOLE OR IN PART WITHOUT MOTOROLA'S CONSENT. © COPYRIGHT, MOTOROLA. THIS DOES NOT IMPLY PUBLICATION	PROJECT NAME <b>B 84016326001_a.cpm</b>	REV <b>01</b>	CAD FILE NAME:
PAGE 67 OF 77			

MOTOROLA MOBILITY CONFIDENTIAL RESTRICTED-MDB TRACKED TRACKEDANDBLOCKED

# PMA8084: VREGS

REF 2300-2349

## LINEAR REGULATORS

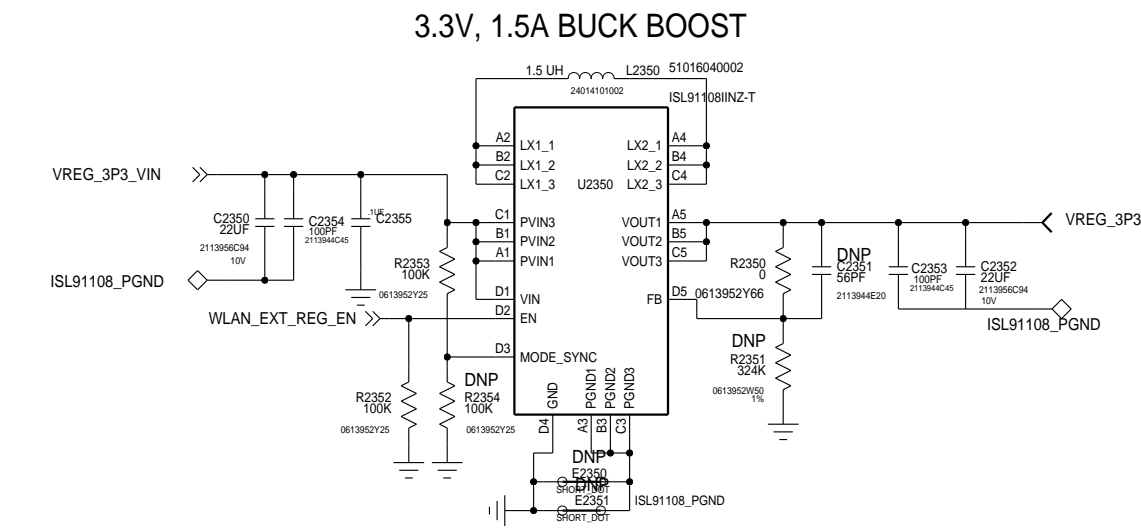
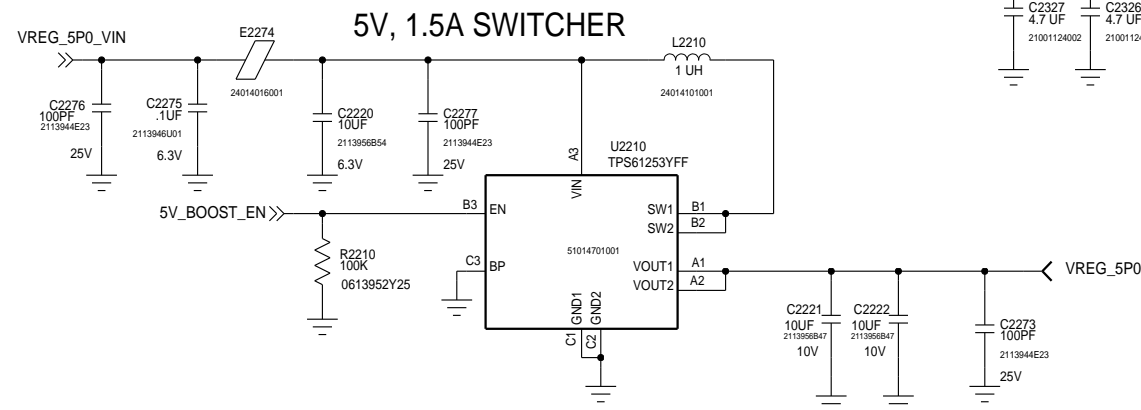
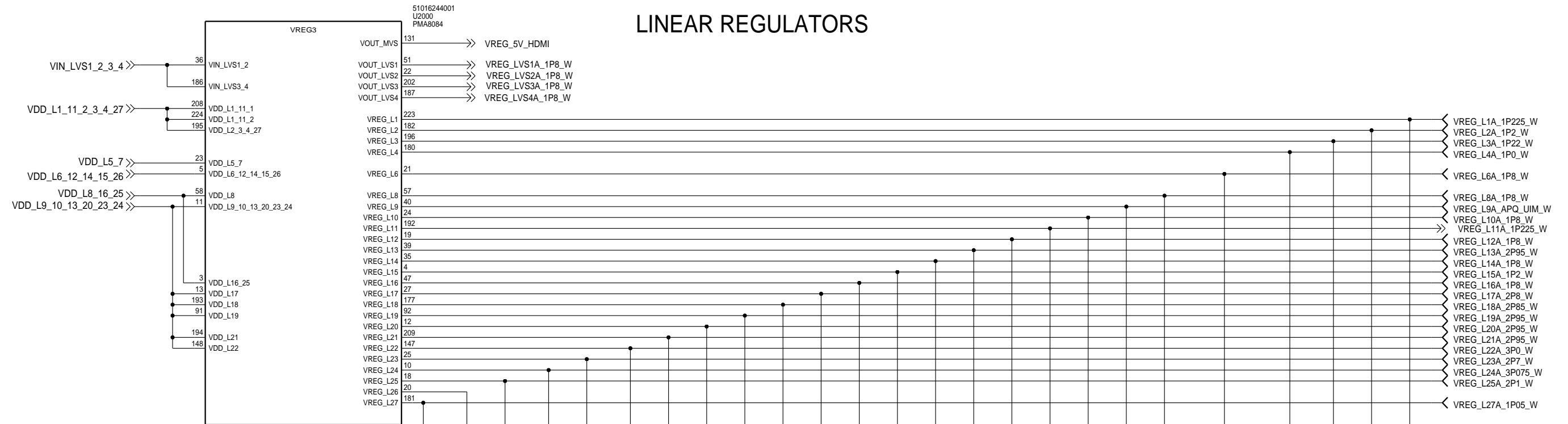

MOTOROLA MOBILITY CONFIDENTIAL RESTRICTED-MDB TRACKED TRACKEDANDBLOCKED

APPROVALS		 <b>MOTOROLA</b> MOBILE DEVICES	
ENGINEER:		BLOCK TITLE:	
LAST MODIFIED BY:		ap_pmic	
Thu Jun 05 16:04:44 2014		PROJECT NAME	
MOTOROLA CONFIDENTIAL RESTRICTED <small>THE DRAWING ON THIS PRINT AND INFORMATION THEREWITH ARE PROPRIETARY TO MOTOROLA AND SHALL NOT BE USED OR DISCUSSED IN WHOLE OR IN PART WITHOUT MOTOROLA'S CONSENT. © COPYRIGHT, MOTOROLA. THIS DOES NOT IMPLY PUBLICATION</small>		B 84016326001_a.cpm	
		REV 01	
		PAGE 68 OF 77	

# MDM9x25M POWER

REF 3200-3249

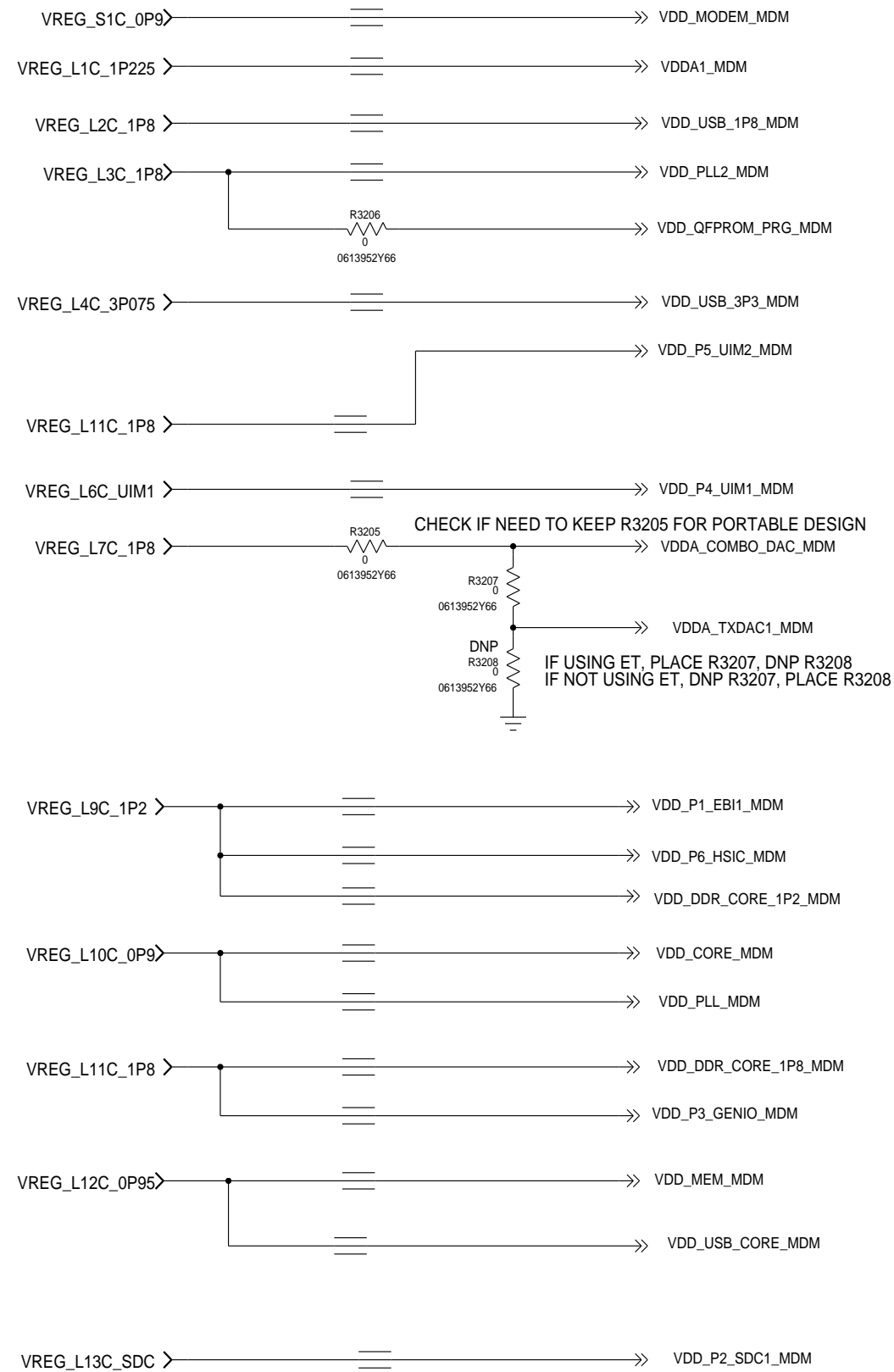

BASED ON 80-NJ851-41 REV.A

APPROVALS		<b>MOTOROLA</b> MOBILE DEVICES	
ENGINEER: W00281		BLOCK TITLE:	
LAST MODIFIED BY: W00281 Thu Jun 05 15:25:08 2014		<b>block_mdm9x25m_pm8019</b>	
MOTOROLA CONFIDENTIAL RESTRICTED <small>THE DRAWING ON THIS PRINT AND INFORMATION THEREWITH ARE PROPRIETARY TO MOTOROLA AND SHALL NOT BE USED OR DISCUSSED IN WHOLE OR IN PART WITHOUT MOTOROLA'S CONSENT. © COPYRIGHT, MOTOROLA. THIS DOES NOT IMPLY PUBLICATION</small>		PROJECT NAME <b>B</b> 84016326001_a.cpm	REV 01
		CAD FILE NAME:	
		PAGE 69 OF 77	

# MDM9x25M CTRL/ANALOG/JTAG

REF 3300-3399

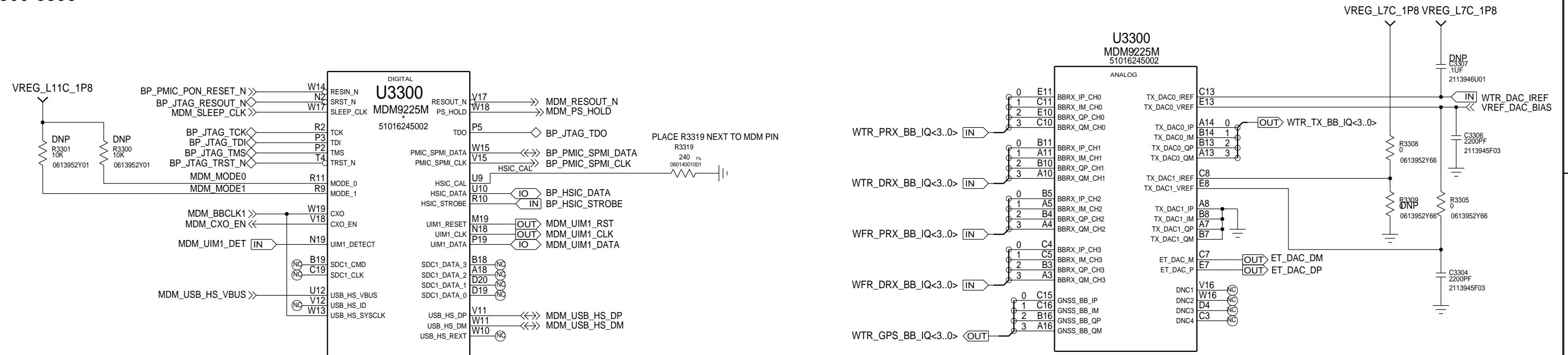

IF USING ET, PLACE R3308 & R3305, DNP R3209  
IF NOT USING ET, DNP R3308 & R3305, PLACE R3309 AND REPLACE C3304 W/ 00HM

NOTE: PLACE R3309W NEAR PIN W10 FOR WING BRD  
DELETE R3309W AND LEAVE PIN W10 NC FOR PORTABLE

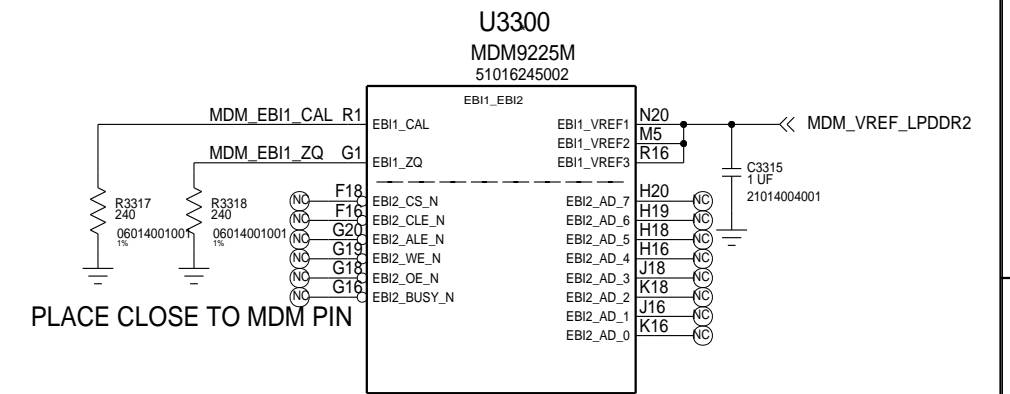
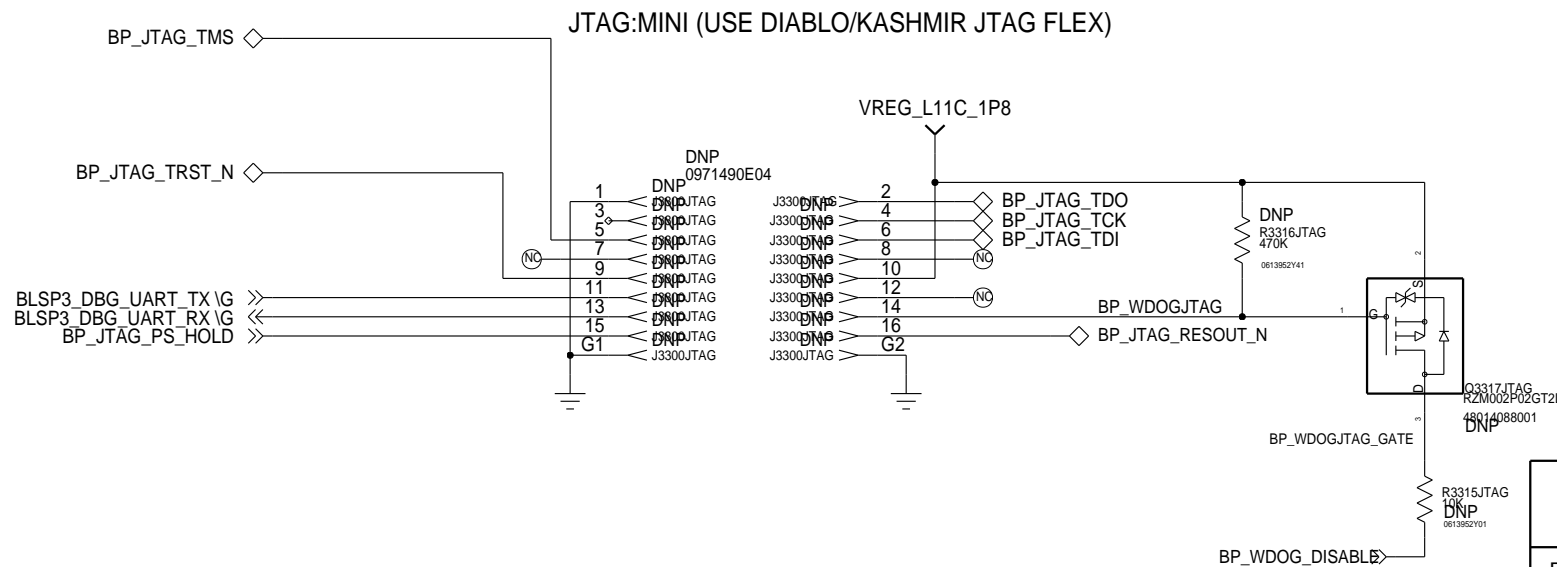

PLACE CLOSE TO MDM PIN

BASED ON 80-NJ851-41 REV.A

APPROVALS		<b>MOTOROLA</b> MOBILE DEVICES	
ENGINEER: THIREN RAYAMAJHI		BLOCK TITLE:	
LAST MODIFIED BY: THIREN RAYAMAJHI Thu Jun 05 15:25:09 2014		<b>block_mdm9x25m_pm8019</b>	
MOTOROLA CONFIDENTIAL RESTRICTED		PROJECT NAME	REV
THE DRAWING ON THIS PRINT AND INFORMATION THEREWITH ARE PROPRIETARY TO MOTOROLA AND SHALL NOT BE USED OR DISCUSSED IN WHOLE OR IN PART WITHOUT MOTOROLA'S CONSENT. © COPYRIGHT, MOTOROLA. THIS DOES NOT IMPLY PUBLICATION		B 84016326001_a.cpm	01
		CAD FILE NAME:	PAGE 70 OF 77

# MDM9x25M POWER1/2

REF 3400-3499

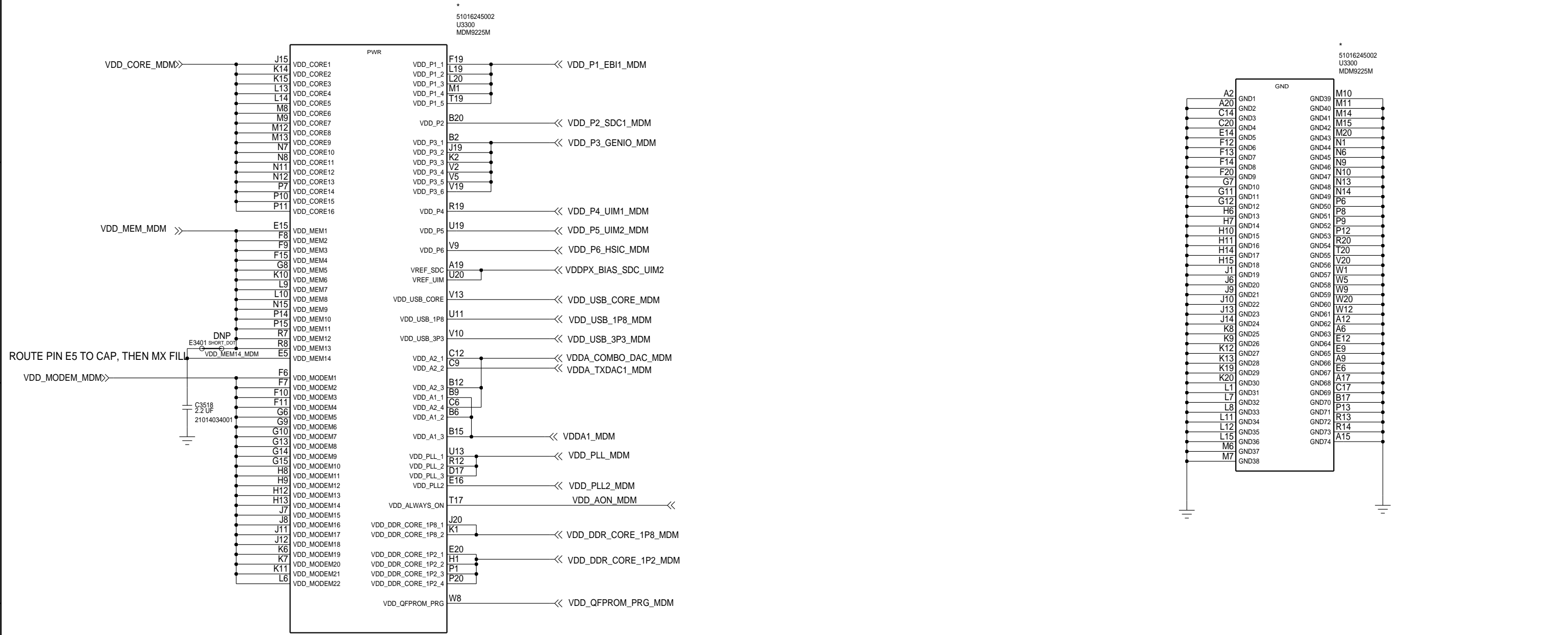

BASED ON 80-NJ851-41 REV.A

APPROVALS		 <b>MOTOROLA</b> MOBILE DEVICES	
ENGINEER: W00281		BLOCK TITLE:	
LAST MODIFIED BY: W00281 Thu Jun 05 15:25:10 2014		block_mdm9x25m_pm8019	
MOTOROLA CONFIDENTIAL RESTRICTED <small>THE DRAWING ON THIS PRINT AND INFORMATION THEREWITH ARE PROPRIETARY TO MOTOROLA AND SHALL NOT BE USED OR DISCUSSED IN WHOLE OR IN PART WITHOUT MOTOROLA'S CONSENT.          © COPYRIGHT, MOTOROLA. THIS DOES NOT IMPLY PUBLICATION</small>		PROJECT NAME <b>B</b> 84016326001_a.cpm	REV 01
		CAD FILE NAME:	
		PAGE 71 OF 77	

# MDM9x25M POWER 2/2

## REF 3500-3599

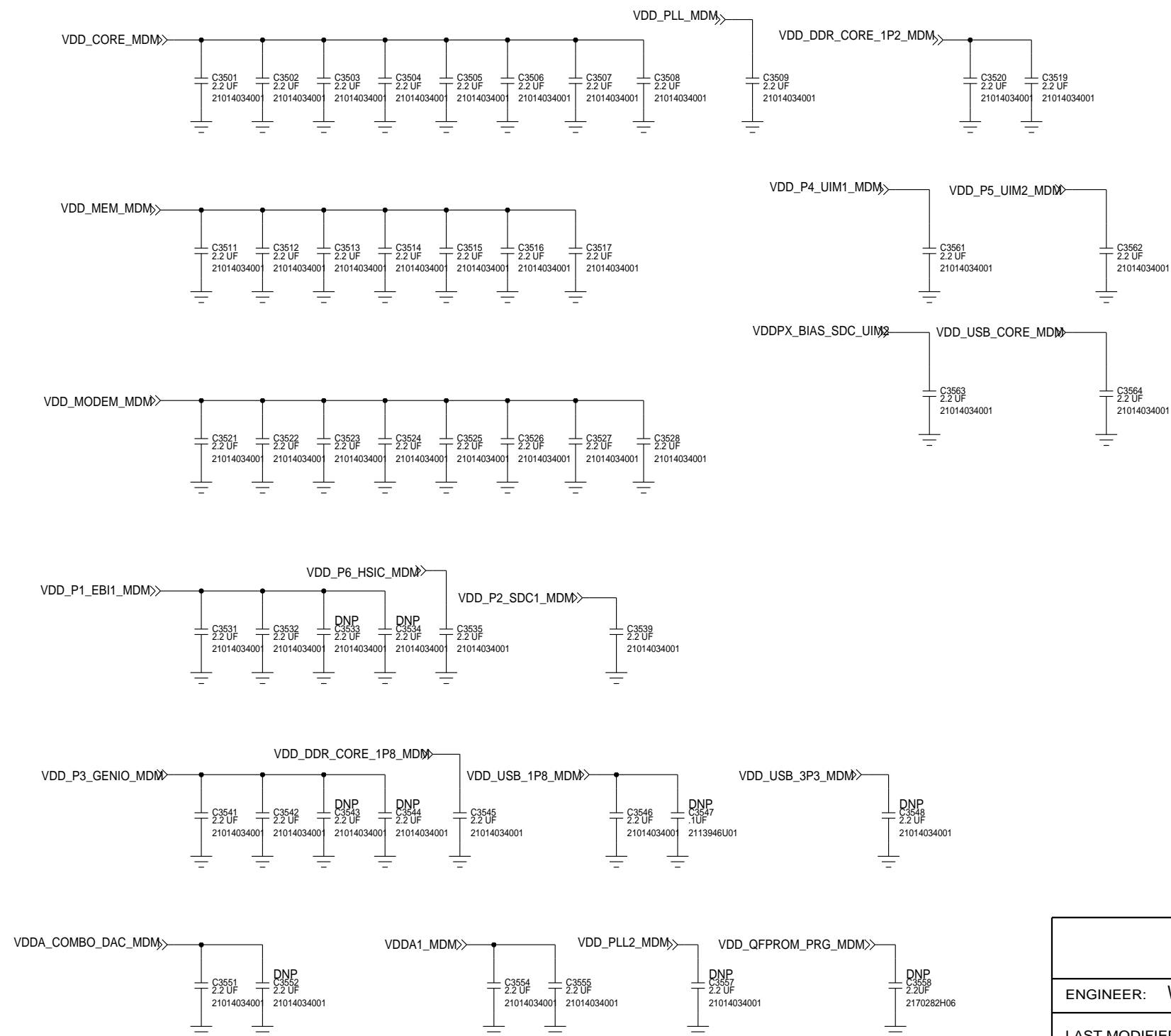

BASED ON 80-NJ851-41 REV.A

APPROVALS		<b>MOTOROLA</b> MOBILE DEVICES	
ENGINEER: W00281		BLOCK TITLE: <b>block_mdm9x25m_pm8019</b>	
LAST MODIFIED BY: W00281 Thu Jun 05 15:25:11 2014		PROJECT NAME 84016326001_a.cpm	
MOTOROLA CONFIDENTIAL RESTRICTED <small>THE DRAWING ON THIS PRINT AND INFORMATION THEREWITH ARE PROPRIETARY TO MOTOROLA AND SHALL NOT BE USED OR DISCUSSED IN WHOLE OR IN PART WITHOUT MOTOROLA'S CONSENT. © COPYRIGHT, MOTOROLA. THIS DOES NOT IMPLY PUBLICATION</small>		REV 01	CAD FILE NAME: PAGE 72 OF 77



# MDM9x25M GPIO MAP

REF 3600-3699

GPIO Pin	Label	GPIO Pin	Label
0	R18	GPIO_38	H5
1	U18	GPIO_39	H2
2	T18	GPIO_40	H3
3	P18	GPIO_41	G3
4	U15	GPIO_42	F2
5	U14	GPIO_43	F1
6	V14	GPIO_44	D3
7	U16	GPIO_45	C1
8	U3	GPIO_46	G5
9	U4	GPIO_47	F5
10	W2	GPIO_48	E3
11	V3	GPIO_49	F5
12	V7	GPIO_50	N5
13	V6	GPIO_51	N3
14	W7	GPIO_52	T3
15	U8	GPIO_53	E2
16	M18	GPIO_54	D1
17	M16	GPIO_55	E1
18	N16	GPIO_56	E1
19	L16	GPIO_57	T1
20	D18	GPIO_58	R6
21	C18	GPIO_59	R3
22	E19	GPIO_60	V8
23	E18	GPIO_61	U7
24	P16	GPIO_62	W4
25	L18	GPIO_63	W3
26	L5	GPIO_64	U6
27	M3	GPIO_65	T2
28	K3	GPIO_66	R15
29	L3	GPIO_67	V4
30	M2	GPIO_68	U17
31	K5	GPIO_69	V6
32	B1	GPIO_70	W1
33	C2	GPIO_71	U2
34	J5	GPIO_72	U3
35	L2	GPIO_73	U1
36	J3	GPIO_74	U5
37	J2	GPIO_75	R5

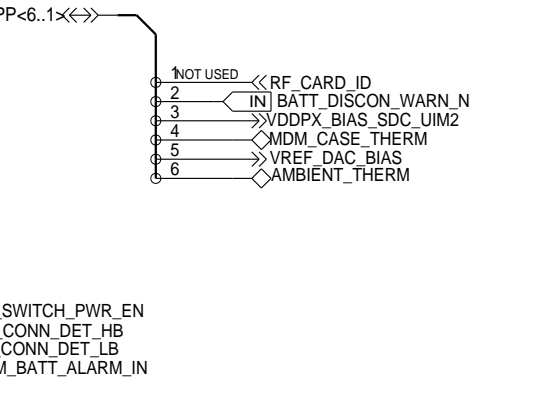
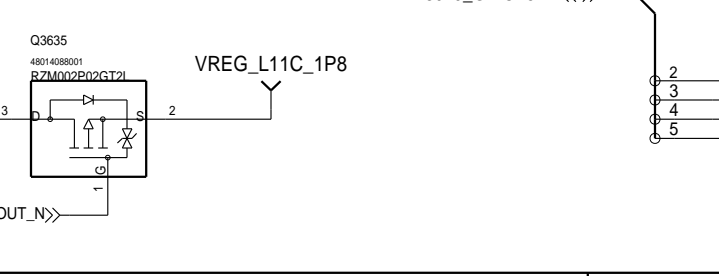
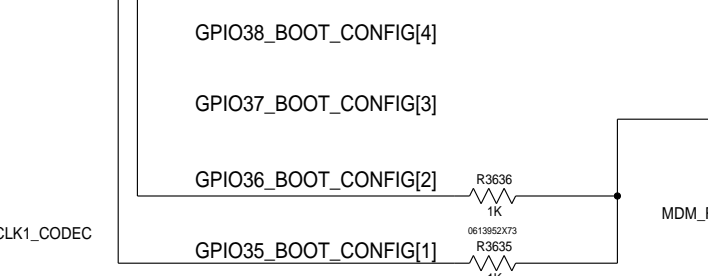
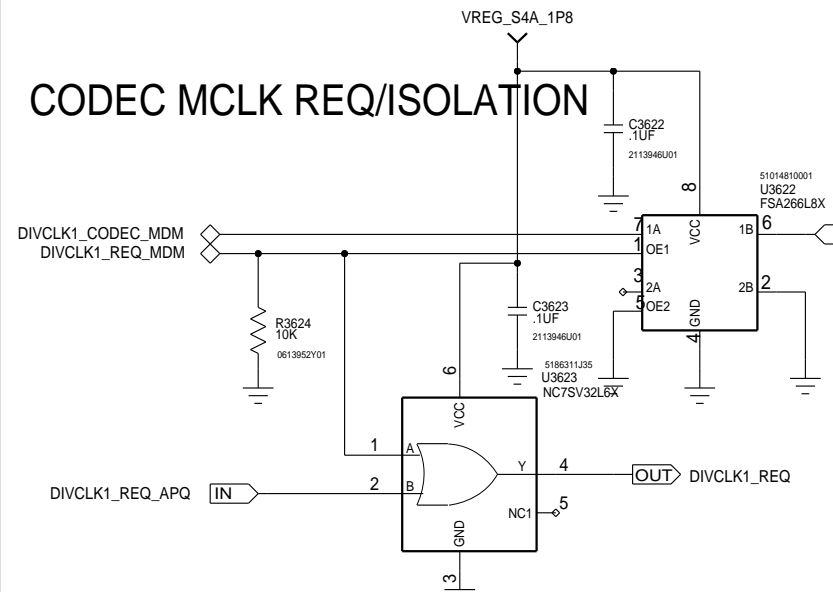
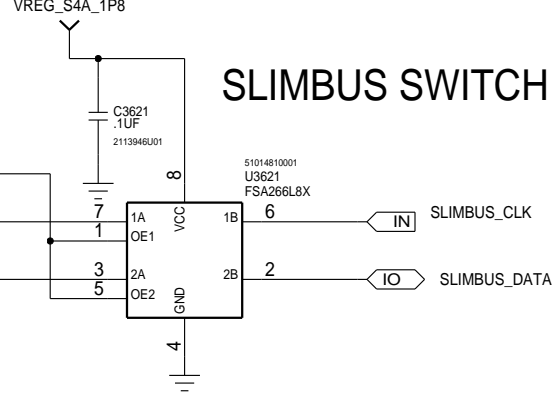
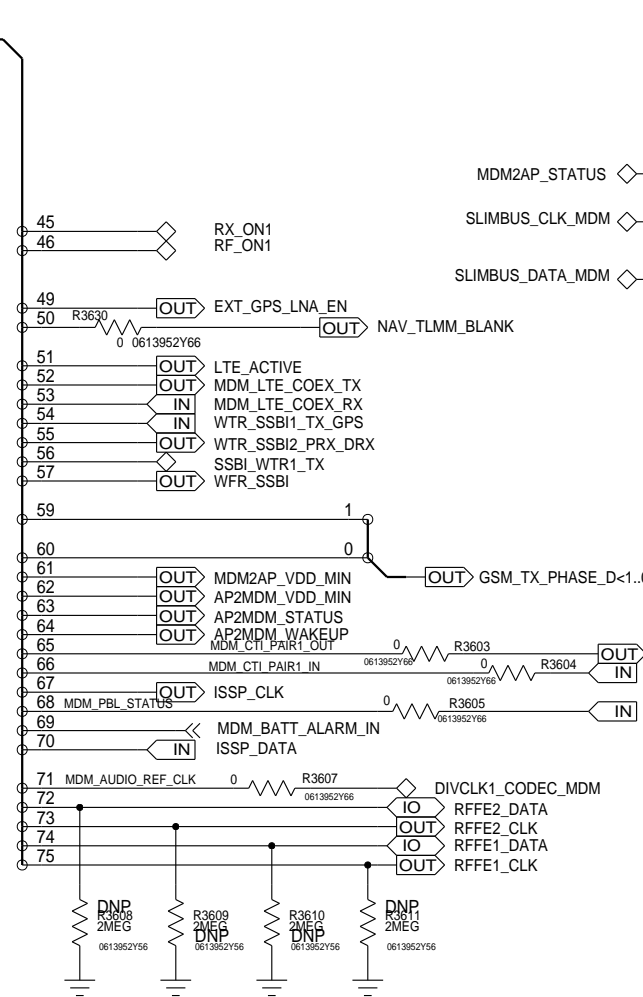
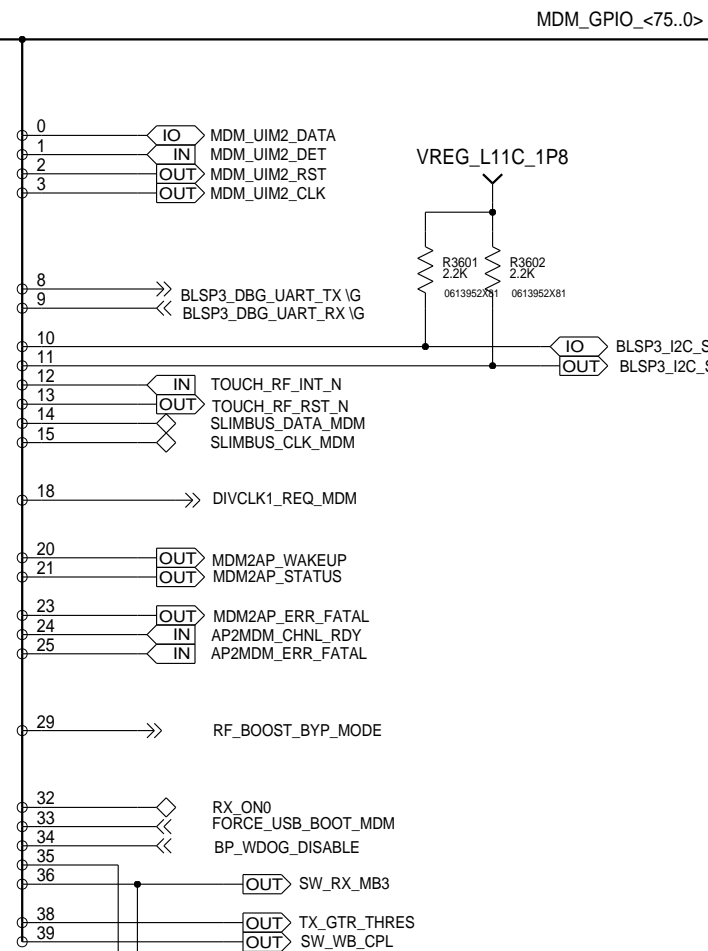

BOOT_CONFIG[4:1]	Boot device
0b00000	NAND followed by USB
0b00001	NAND
0b00010	USB
0b00011	HSIC

**APPROVALS**

ENGINEER: W00281

LAST MODIFIED BY: W00281  
Thu Jun 05 15:25:12 2014

MOTOROLA CONFIDENTIAL RESTRICTED

THE DRAWING ON THIS PRINT AND INFORMATION THEREWITH ARE PROPRIETARY TO MOTOROLA AND SHALL NOT BE USED OR DISCUSSED IN WHOLE OR IN PART WITHOUT MOTOROLA'S CONSENT.

© COPYRIGHT, MOTOROLA. THIS DOES NOT IMPLY PUBLICATION

**MOTOROLA**  
MOBILE DEVICES

BLOCK TITLE:  
**block\_mdm9x25m\_pm8019**

PROJECT NAME	REV
B 84016326001_a.cpm	01

CAD FILE NAME:

PAGE 73 OF 77

BASED ON 80-NJ851-41 REV.A

# PM8019 POWER

REF 3900-3949

## SUPPLIES

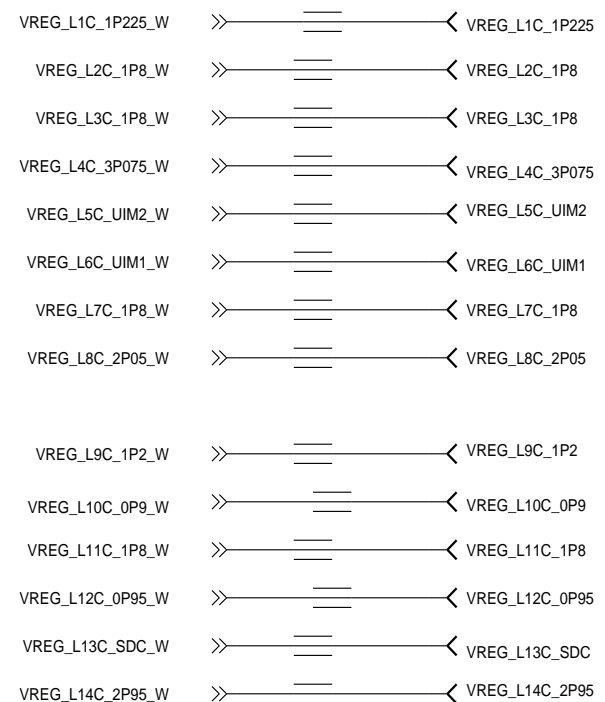
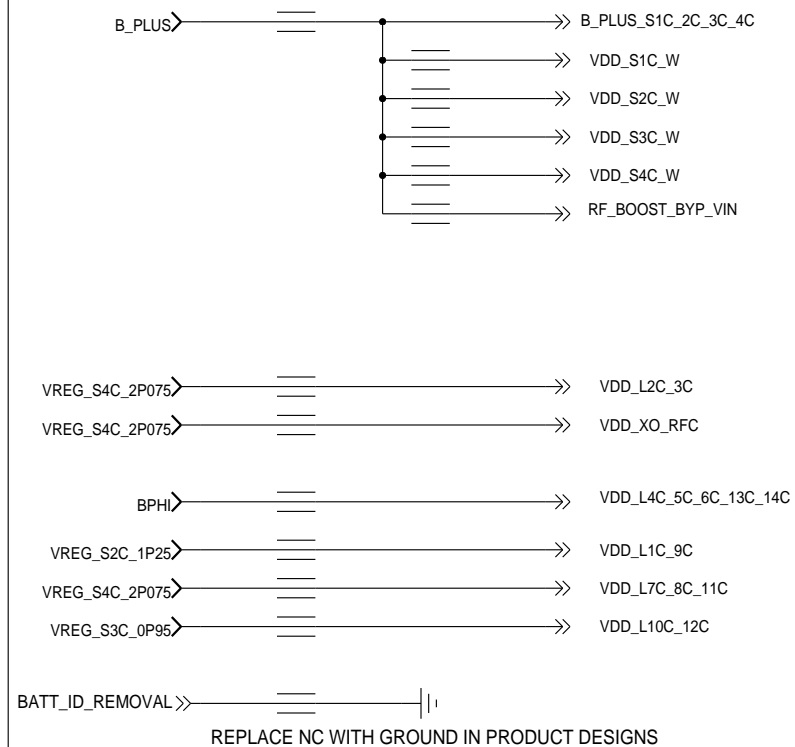

BASED ON 80-NJ851-41 REV.A

APPROVALS		<b>MOTOROLA</b> MOBILE DEVICES	
ENGINEER: W00281		BLOCK TITLE:	
LAST MODIFIED BY: W00281 Thu Jun 05 15:25:13 2014		<b>block_mdm9x25m_pm8019</b>	
MOTOROLA CONFIDENTIAL RESTRICTED <small>THE DRAWING ON THIS PRINT AND INFORMATION THEREWITH ARE PROPRIETARY TO MOTOROLA AND SHALL NOT BE USED OR DISCUSSED IN WHOLE OR IN PART WITHOUT MOTOROLA'S CONSENT.          © COPYRIGHT, MOTOROLA. THIS DOES NOT IMPLY PUBLICATION</small>		PROJECT NAME <b>B</b> 84016326001_a.cpm	REV 01
		CAD FILE NAME:	
		PAGE 74 OF 77	

# PM8019 CONTROL/CLOCK

REF 3700-3799

OR GATE FORCE BP RESET  
 BP\_PMIC\_RESIN\_N LOW  
 WHEN BOTH KYPD\_PWR\_N AND PM1\_RESIN\_N LOW

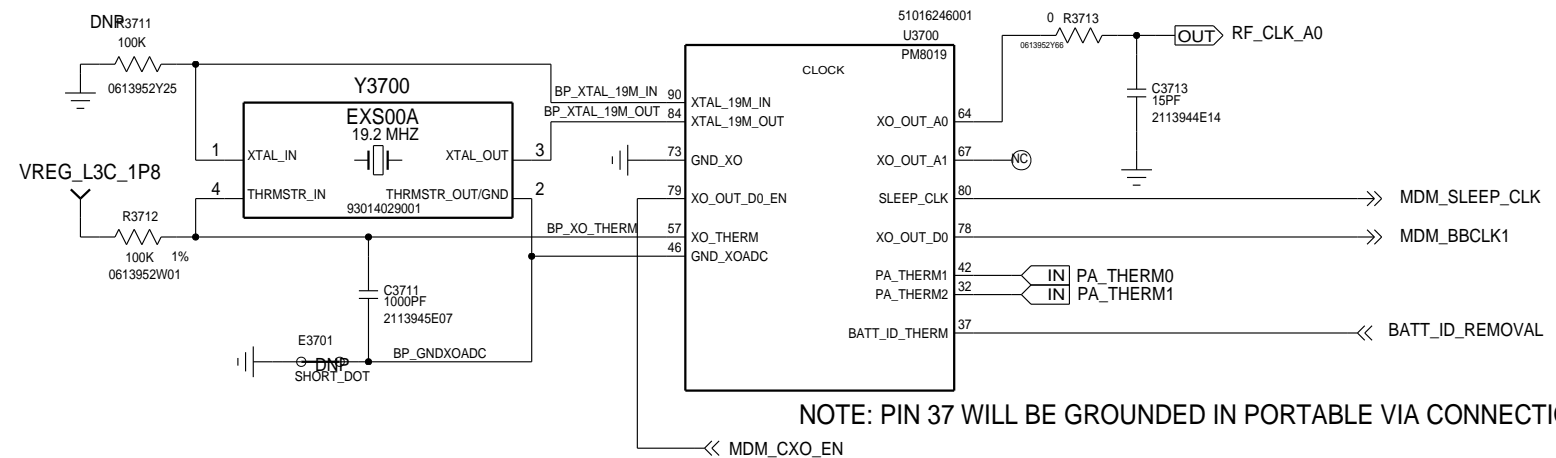
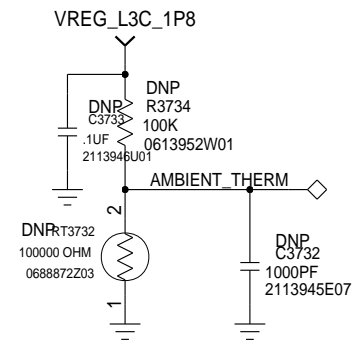
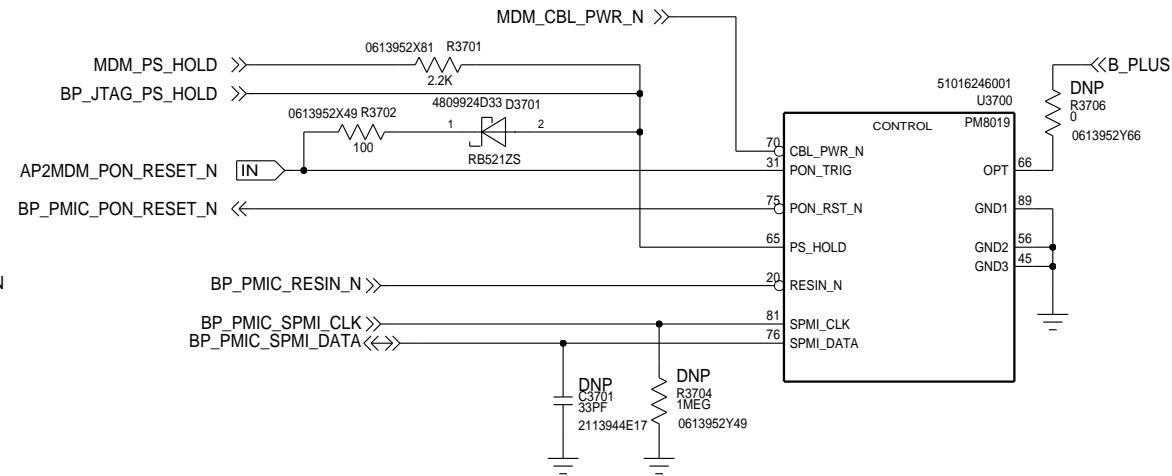
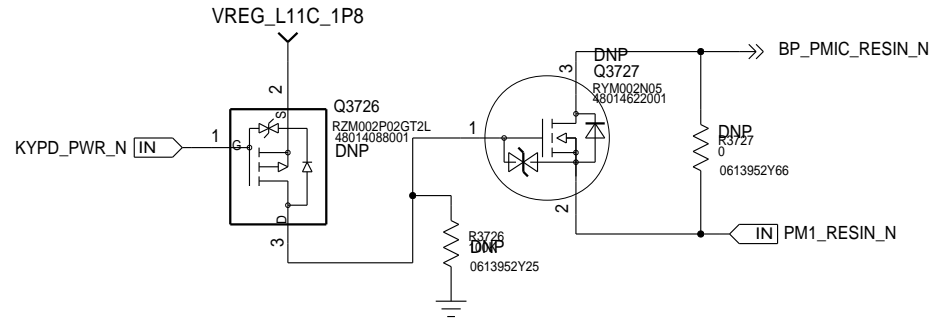

NOTE: PIN 37 WILL BE GROUNDED IN PORTABLE VIA CONNECTION ON PM8019 POWER SHEET

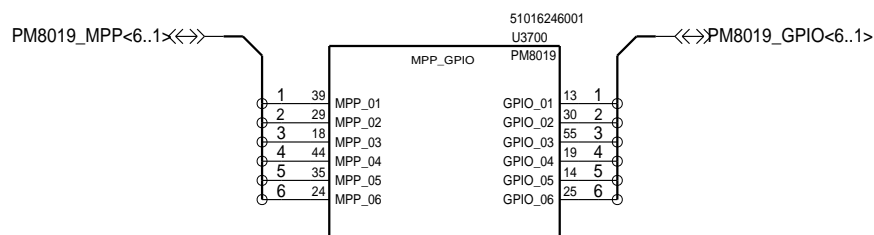

BASED ON 80-NJ851-41 REV.A

APPROVALS		 <b>MOTOROLA</b> MOBILE DEVICES	
ENGINEER: W00281		BLOCK TITLE:	
LAST MODIFIED BY: W00281 Mon Jul 21 15:13:45 2014		<b>block_mdm9x25m_pm8019</b>	
MOTOROLA CONFIDENTIAL RESTRICTED <small>THE DRAWING ON THIS PRINT AND INFORMATION THEREWITH ARE PROPRIETARY TO MOTOROLA AND SHALL NOT BE USED OR DISCUSSED IN WHOLE OR IN PART WITHOUT MOTOROLA'S CONSENT.          © COPYRIGHT, MOTOROLA. THIS DOES NOT IMPLY PUBLICATION</small>		PROJECT NAME	REV
		B 84016326001_a.cpm	01
CAD FILE NAME:		PAGE 75 OF 77	

# PM8019 SMPS VREGS

REF 3800-3899

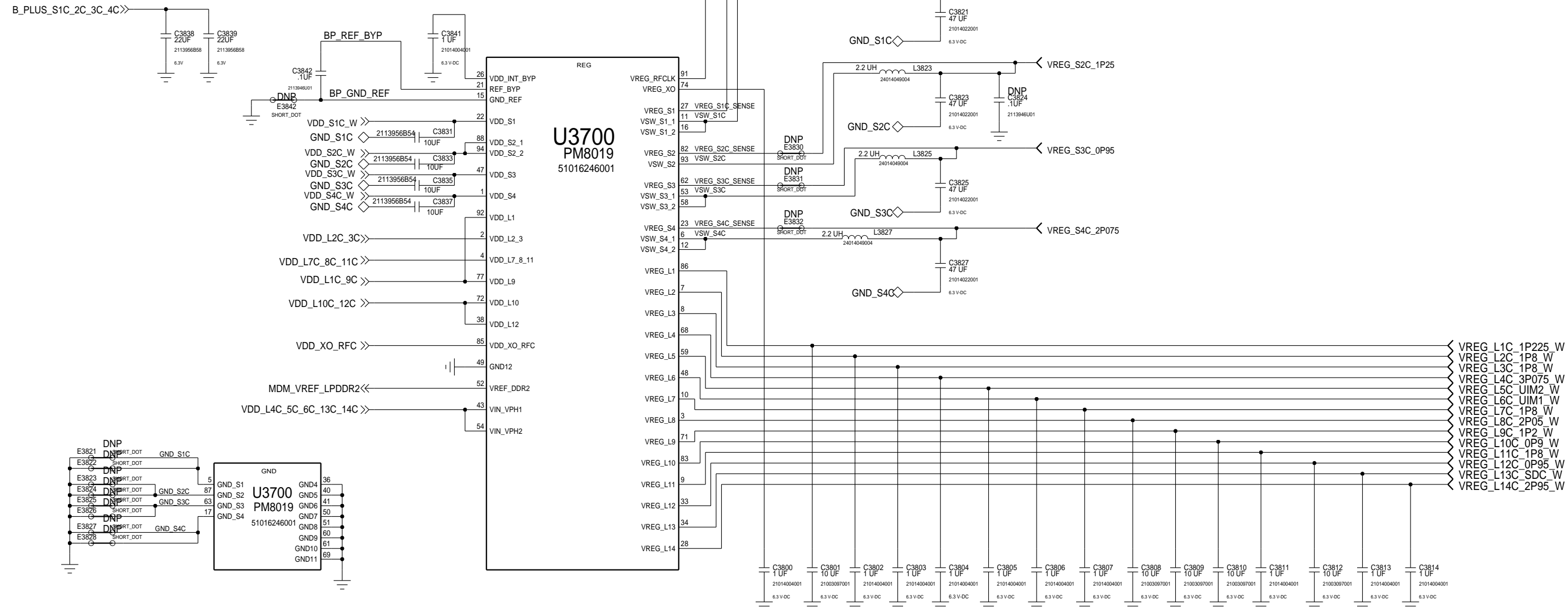



BASED ON 80-NJ851-41 REV.A

APPROVALS		<b>MOTOROLA</b> MOBILE DEVICES	
ENGINEER: W00281		BLOCK TITLE:	
LAST MODIFIED BY: W00281 Thu Jun 05 15:25:15 2014		<b>block_mdm9x25m_pm8019</b>	
MOTOROLA CONFIDENTIAL RESTRICTED <small>THE DRAWING ON THIS PRINT AND INFORMATION THEREWITH ARE PROPRIETARY TO MOTOROLA AND SHALL NOT BE USED OR DISCUSSED IN WHOLE OR IN PART WITHOUT MOTOROLA'S CONSENT. © COPYRIGHT, MOTOROLA. THIS DOES NOT IMPLY PUBLICATION</small>		PROJECT NAME <b>B 84016326001_a.cpm</b>	REV <b>01</b>
		CAD FILE NAME:	PAGE 76 OF 77

# PM8019 BST/BYP

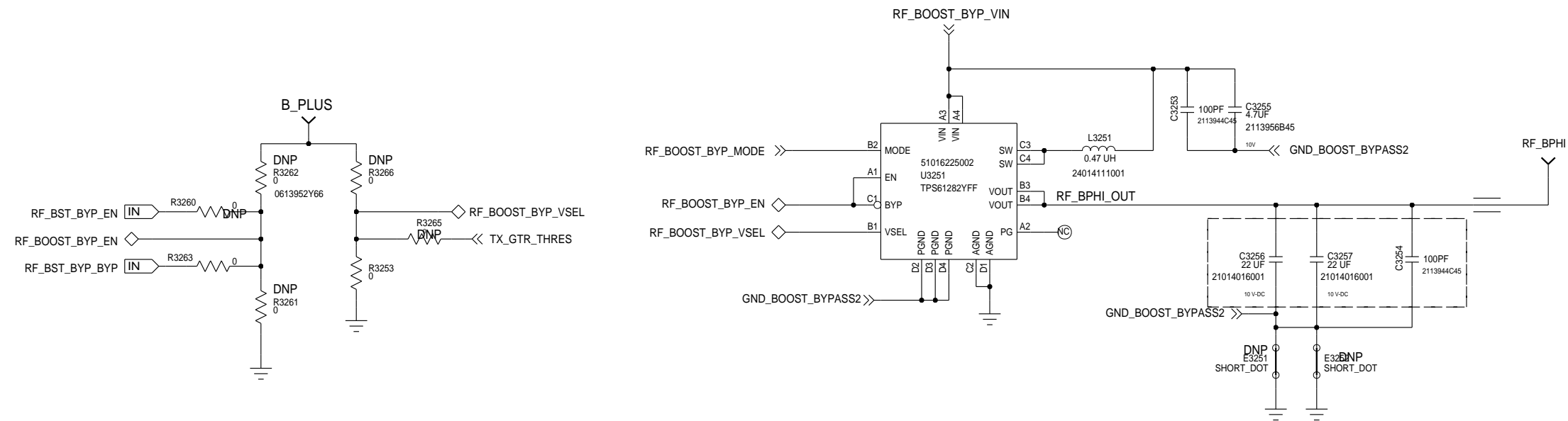
REF 3250-3299



APPROVALS		 <b>MOTOROLA</b> MOBILE DEVICES	
ENGINEER: W00281		BLOCK TITLE:	
LAST MODIFIED BY: W00281 Thu Jun 05 15:25:15 2014		block_mdm9x25m_pm8019	
MOTOROLA CONFIDENTIAL RESTRICTED <small>THE DRAWING ON THIS PRINT AND INFORMATION THEREWITH ARE PROPRIETARY TO MOTOROLA AND SHALL NOT BE USED OR DISCUSSED IN WHOLE OR IN PART WITHOUT MOTOROLA'S CONSENT.          © COPYRIGHT, MOTOROLA. THIS DOES NOT IMPLY PUBLICATION</small>		PROJECT NAME <b>B</b> 84016326001_a.cpm	REV 01
		CAD FILE NAME:	
		PAGE 77 OF 77	