



Level 1 and 2 Service Manual

# Product Family C23

## Wireless Telephone



V70  
GSM 900/1800 MHz & GPRS Technologies



---

## Table of Contents

<b>Introduction</b>	<b>1</b>
Product Identification	1
Product Names	1
Product Changes	1
Regulatory Agency Compliance	1
Computer Program Copyrights	2
About This Service Manual	2
Warranty Service Policy	3
Parts Replacement	4
<b>Specifications</b>	<b>5</b>
<b>Product Overview</b>	<b>7</b>
Features	7
<b>General Operation</b>	<b>10</b>
Controls, Indicators, and Input / Output (I/O) Connectors	10
User Interface Menu Structure	12
Alert Settings	12
Battery Function	13
Operation	13
<b>Tools and Test Equipment</b>	<b>15</b>
<b>Disassembly</b>	<b>16</b>
Removing and Replacing the Battery Cover and Battery	16
Removing and Replacing the Subscriber Identity Module (SIM)	19
Removing and Replacing the Rear Housing Cover	20
Removing and Replacing the Rear Transceiver Housing	21
Removing and Replacing the Antenna	22
Removing and Replacing the Transceiver Board Assembly	23
Removing and Replacing the Daughter PC Board	24
Removing and Replacing the Real Time Clock Battery	25
Removing and Replacing the Keypad	26
Removing and Replacing the Keypad PCB Assembly	26
Removing and Replacing the Ring Bezel Assembly	28
Removing and Replacing the Display Module	29
Removing and Replacing the Microphone	32
<b>Subscriber Identity Module (SIM) and Identification Label</b>	<b>33</b>
SIM	33
Identification	33
<b>Troubleshooting</b>	<b>35</b>
Manual Test Mode	35
Manual Test Mode Commands	35
Troubleshooting Chart	37
Programming: Software Upgrade and Flexing	38
<b>Part Number Charts</b>	<b>39</b>
Related Publications	39
Exploded View Diagram	40
Exploded View Parts List	41
Model-Specific Part Numbers	42
Accessories	43
<b>Index</b>	<b>Index-1</b>



## Introduction

Motorola® Inc. maintains a worldwide organization that is dedicated to provide responsive, full-service customer support. Motorola products are serviced by an international network of company-operated product care centers as well as authorized independent service firms.

Available on a contract basis, Motorola Inc. offers comprehensive maintenance and installation programs which enable customers to meet requirements for reliable, continuous communications.

To learn more about the wide range of Motorola service programs, contact your local Motorola products representative or the nearest Customer Service Manager.

## Product Identification

Motorola products are identified by the model number on the housing. Use the entire model number when inquiring about the product. Numbers are also assigned to chassis and kits. Use these numbers when requesting information or ordering replacement parts.

## Product Names

Product names included in Product Family C23 (PF C23) telephones are listed on the front cover. Product names are subject to change without notice. Some product names, as well as some frequency bands, are available only in certain markets.

## Product Changes

When electrical, mechanical or production changes are incorporated into Motorola products, a revision letter is assigned to the chassis or kit affected, for example; -A, -B, or -C, and so on.

The chassis or kit number, complete with revision number is imprinted during production. The revision letter is an integral part of the chassis or kit number and is also listed on schematic diagrams and printed circuit board layouts.

## Regulatory Agency Compliance

This device complies with Part 15 of the FCC Rules. Operation is subject to the following conditions:

1. This device may not cause any harmful interference, and
2. this device must accept interference received, including interference that may cause undesired operation.

This class B device also complies with all requirements of the Canadian Interference-Causing Equipment Regulations (ICES-003).

Cet appareil numérique de la classe B respecte toutes les exigences du Règlement sur le matériel brouilleur du Canada.

---

## Computer Program Copyrights

The Motorola products described in this manual may include Motorola computer programs stored in semiconductor memories or other media that are copyrighted with all rights reserved worldwide to Motorola. Laws in the United States and other countries preserve for Motorola, Inc. certain exclusive rights to the copyrighted computer programs, including the exclusive right to copy, reproduce, modify, decompile, disassemble, and reverse-engineer the Motorola computer programs in any manner or form without Motorola's prior written consent. Furthermore, the purchase of Motorola products shall not be deemed to grant either directly or by implication, estoppel, or otherwise, any license or rights under the copyrights, patents, or patent applications of Motorola, except for a nonexclusive license to use the Motorola product and the Motorola computer programs with the Motorola product.

## About This Service Manual

Using this service manual and the suggestions contained in it assures proper installation, operation, and maintenance of PF C23 telephones. Refer questions about this manual to the nearest Customer Service Manager.

A product family is the group of products having the same Account Product Code (APC). To locate the APC on a device, refer to "Mechanical Serial Number (MSN)" later in this manual.

### Audience

This document aids service personnel in testing and repairing PF C23 telephones. Service personnel should be familiar with electronic assembly, testing, and troubleshooting methods, and with the operation and use of associated test equipment.

Use of this document assures proper installation, operation, and maintenance of Motorola products and equipment. It contains all service information required for the equipment described and is current as of the printing date.

### Scope

The scope of this document is to provide the reader with basic information relating to PF C23 telephones, and also to provide procedures and processes for repairing the units at Level 1 and 2 service centers including:

- Unit swap out
- Repairing of mechanical faults
- Basic modular troubleshooting
- Testing and verification of unit functionality
- Initiate warranty claims and send faulty modules to Level 3 or 4 repair centers.

---

## Conventions

Special characters and typefaces, listed and described below, are used in this publication to emphasize certain types of information.



*Note: Emphasizes additional information pertinent to the subject matter.*



*Caution: Emphasizes information about actions which may result in equipment damage.*



*Warning: Emphasizes information about actions which may result in personal injury.*



Keys to be pressed are represented graphically. For example, instead of “Press the Enter Key”, you will see “Press ”.

Information from a screen is shown in text as similar as possible to what appears in the display. For example, **ALERTS** or **ALERTS** or **ALERTS**.

Information that you need to type is printed in **boldface type**

## Revisions

Any changes that occur after manuals are printed are described in publication revision bulletins (*PMRs*). These bulletins provide change information that can include new parts listing data, schematic diagrams, and printed board layouts.

## Warranty Service Policy

The product will be sold with the standard 12 months warranty terms and conditions. Accidental damage, misuse, and extended warranties offered by retailers are not supported under warranty. Non warranty repairs are available at agreed fixed repair prices.

### Out of Box Failure Policy

The standard out of box failure criteria applies. Customer units that fail very early on after the date of sale, are to be returned to Manufacturing for root cause analysis, to guard against epidemic criteria. Manufacturing to bear the costs of early life failure.

### Product Support

Customer's original units will be repaired but not refurbished as standard. Appointed Motorola Service Hubs will perform warranty and non-warranty field service for level 2 (assemblies) and level 3 (limited PCB component). The Motorola HTC centers will perform level 4 (full component) repairs.

## Customer Support

Customer support is available through dedicated Call Centers and in-country help desks. Product Service training should be arranged through the local Motorola Support Center.

## Parts Replacement

When ordering replacement parts or equipment, include the Motorola part number and description used in the service manual or supplement.

When ordering crystals or channel elements, specify the Motorola part number, description, crystal frequency, and operating frequency desired.

When the Motorola part number of a component is not known, use the product model number or other related major assembly along with a description of the related major assembly and of the component in question.

In the U.S.A., to contact Motorola, Inc. on your TTY, call: 800-793-7834

## Accessories and Aftermarket Division (AAD)

Replacement parts, test equipment, and manuals can be ordered from AAD.

### U.S.A

Phone: 800-422-4210

FAX: 800-622-6210

### Outside U.S.A.

Phone: 847-538-8023

FAX: 847-576-3023



# Specifications

**Table 1. Specifications**

General Function	Specification
Frequency Range GSM	880-915 MHz Tx (with EGSM) 925-960 MHz Rx
Frequency Range DCS	1710-1785 MHz Tx 1805-1880 MHz Rx
Channel Spacing	200 kHz
Channels	174 EGSM, 374 DCS carriers with 8 ch. per carrier
Modulation	GMSK at BT = 0.3
Transmitter Phase Accuracy	5 Degrees RMS, 20 Degrees peak
Duplex Spacing	45 MHz GSM, 95 MHz DCS
Frequency Stability	± 0.10 ppm of the downlink frequency (Rx)
Operating Voltage	+3.0V dc to +5.1V dc (battery) +4.4V dc to +6.5V dc (external connector)
Average Transmit Current	300 mA
Average Stand-by Current	7 mA
Dimensions	94 mm x 38 mm x 18.3 mm (3.7 inches x 1.5 inches x 0.72 inches)
Size (Volume)	56 cc (3.42 in <sup>3</sup> )
Weight	83 gm (2.93 oz)
Temperature Range	-10° C to +55° C (+15° F to +130° F)
Battery Life, 700 mAh Li Polymer Battery	Talk time up to 130 minutes Standby time up to 140 hours
Battery Life, 400 mAh Li Polymer Battery	Talk time up to 130 minutes Standby time up to 140 hours
	All talk and standby times are approximate and depend on network configuration, signal strength, and features selected. Standby times are quoted as a range from DRX=2 to DRX=9. Talk times are quoted as a range from DTX off to DTX on.

Transmitter Function	
RF Power Output	33 dBm nominal GSM 30 dBm nominal DCS
Output Impedance	50 ohms nominal
Spurious Emissions	-36 dBm from 0.1 to 1 GHz, -30 dBm from 1 to 4 GHz

Receiver Function	
Receive Sensitivity	-107 dBm GSM, -105 dBm DCS
RX bit error rate (100k bits) Type II	< 2%
Channel Hop Time	500 microseconds
Time to Camp	Approximately 5-10 seconds

---

Speech Coding Function	Specification
Speech Coding Type	Regular pulse excitation / linear predictive coding with long term prediction (RPE LPC with LTP)
Bit Rate	13.0 kbps
Frame Duration	20 ms
Block Length	260 bits
Classes	Class 1 bits = 182 bits; Class 2 bits = 78 bits
Bit Rate with FEC Encoding	22.8 kbps

---

## Product Overview

Motorola PF C23 mobile telephones feature global system for mobile communications (GSM) air interface, general packet radio service (GPRS) transport technology, and wireless application protocol (WAP) Internet browser. PF C23 telephones incorporate a simplified icon and list-based user interface (UI) for easier operation, allow short message service (SMS) text messaging, and include clock, alarm, datebook, calculator, and caller profiling personal management tools. The PF 23 is a dual band phone that allows roaming within the GSM 900 MHz and digital cellular system (DCS) 1800 MHz bands.

PF C23 telephones support GPRS and SMS in addition to traditional circuit switched transport technologies. GPRS, where available, provides substantial increases in mobile data communications performance and the efficient use of radio spectrum. Data transmission rates for GSM networks can potentially increase from the current rate of 9.6 kbps up to a theoretical maximum of 171.2 kbps. An increased data rate is by no means the only benefit provided by GPRS. A key advantage is the provision of a permanent virtual connection to the network. This “always on” connection is possible because GPRS uses packet data transfer so, for example, email can be downloaded in “background mode.” There is no need for the user to reconnect before requesting a service, eliminating connection set-up delays and adding convenience and immediacy to data services access. The “virtual” nature of this connection means that network resources are not consumed during periods when a user is not actually sending or receiving data.

The telephones are made of polycarbonate plastic with a metal enclosure. The display and speaker, as well as the 16-key keypad, transceiver printed circuit board (PCB), microphone, charger and headphone connectors, and power button are contained within the rotator form-factor housing. The user-replaceable 600 mAh nickel metal hydride (NiMH) battery provides up to 300 minutes of talk time with up to 180 hours of standby time<sup>1</sup>. The phone accepts 3V mini subscriber identity module (SIM) cards which fit into the SIM holder next to the battery. These telephones feature a 96 x 64 pixel 800 square millimeter high-resolution graphics display and an internal antenna.

## Features

PF C23 telephones use advanced, self-contained, sealed, custom integrated circuits to perform the complex functions required for GSM GPRS communication. Aside from the space and weight advantage, microcircuits enhance basic reliability, simplify maintenance, and provide a wide variety of operational functions.

Features available in this family of telephones include:

- Lower voltage technology that provides increased standby and talk times
- Extended GSM (EGSM) channels
- Tri-coder/decoder (CODEC) that allows full rate, half rate, and enhanced full rate modes of transmission
- Supports SMS, concatenated SMS, and cell broadcast messages<sup>2</sup>
- Supports GPRS, circuit switched, and SMS networks<sup>2</sup>
- WAP 1.1 compliant<sup>2</sup>

---

1. All talk and standby times are approximate and depend on network configuration, signal strength, and features selected. Standby times are quoted as a range from DRX=2 to DRX=9. Talk times are quoted as a range from DTX off to DTX on.

2. Network, subscription and SIM card or service provider dependent feature. Not available in all areas.

- 96 X 64 pixel inverse graphical display with 3 lines of English text, 1 line of icons, and one line of prompts
- Display zoom
- Display animation
- VibraCall® vibrating alert
- Downloadable ring tones<sup>3</sup>
- Voice activation for phone book entries
- Simplified text entry using iTAP™ predictive text entry
- Calling line identification<sup>3</sup>
- Supports call forwarding for incoming voice, fax and data calls<sup>3</sup>
- Supports 3V SIM cards
- SIM Toolkit™ Class 2 (STK)<sup>3</sup>
- Personal management tools: calculator with currency converter, real time clock with date, reminders, and caller profiling
- Phase II Unstructured Supplementary Service Data (USSD)<sup>3</sup>
- Hearing Aid Telephone Interconnection System (HATIS) support
- Micro Browser connection via WAP over GPRS<sup>3</sup>
- Multiple destination SMS
- TrueSync™ Multi-Point Synchronization Capability
- FM Stereo Radio (with optional headset accessory)

### Speaker Dependant Voice Activation

The voice dialing feature allows the user to recall pre-programmed voice numbers simply by pressing the Voice Dial soft key and speaking the desired voice name entry.



*The user cannot place or receive calls while adding voice names to the phone's memory.*



*Because the GSM standard does not provide the option to store voice tags onto the SIM card, voice tags are added to the phone's memory.*

### Wireless Access Protocol (WAP) 1.1 Compliancy

In the WAP environment, access to the Internet is initiated in wireless markup language (WML), which is derived from hypertext markup language (HTML). The request is passed to a WAP gateway which retrieves the information from the server in standard HTML (subsequently filtered to WML) or directly in WML if available. The information is then passed to the mobile subscriber via the mobile network.

The PF C23's microbrowser can be configured for baud, idle timeout, line type, phone number, and connection type.



*Bitmap image data will download as text. If the image is larger than the screen, only part of the image will display.*

<sup>3</sup>. Network, subscription and SIM card or service provider dependent feature. Not available in all areas.



*If the user receives a call while in browser mode, the browser will pause and allow the user to resume after completing the call.*

### **Simplified Text Entry**

Using iTAP™ predictive text entry, pressing a key generates a character and a dynamic dictionary uses this to build and display a set of word or name options. The iTAP™ feature may not be available on the phone in all languages.

### **Caller Line Identification**

Upon receipt of a call, the calling party's phone number is compared to the phone book. If the number matches a phone book entry, that name will be displayed. If there is no phone book entry, the incoming phone number will be displayed. In the event no caller identification information is available, an incoming call message is displayed.



*User must subscribe to a caller line identification service through their service provider.*

### **SIM Toolkit™ - Class 2**

SIM Application Toolkit is a value-added service delivery mechanism that allows GSM operators to customize the services they offer customers, from the occasional user who requests sports news and traffic alerts, to a high call time business user who receives stock alerts and checks flight times. Operators can now create their own value-added services menu quickly and easily in the phone. The customized menu will appear as the first menu and may be updated over-the-air with new services when customers request them.

### **Personal Information Management**

The PF32 telephone contains a built in calendar and phonebook that can be synchronized easily to a computer or PDA.

### **Other Features**

Detailed descriptions of these and the other features can be found in the appropriate PF C23 telephone user guides listed in the Related Publications section toward the end of this manual.

## General Operation

### Controls, Indicators, and Input / Output (I/O) Connectors

The PF C23 telephone's controls are located on the front and side of the device, and on the keyboard as shown in Figure 1. Indicators, in the form of icons, are displayed on the LCD (see Figure 2).

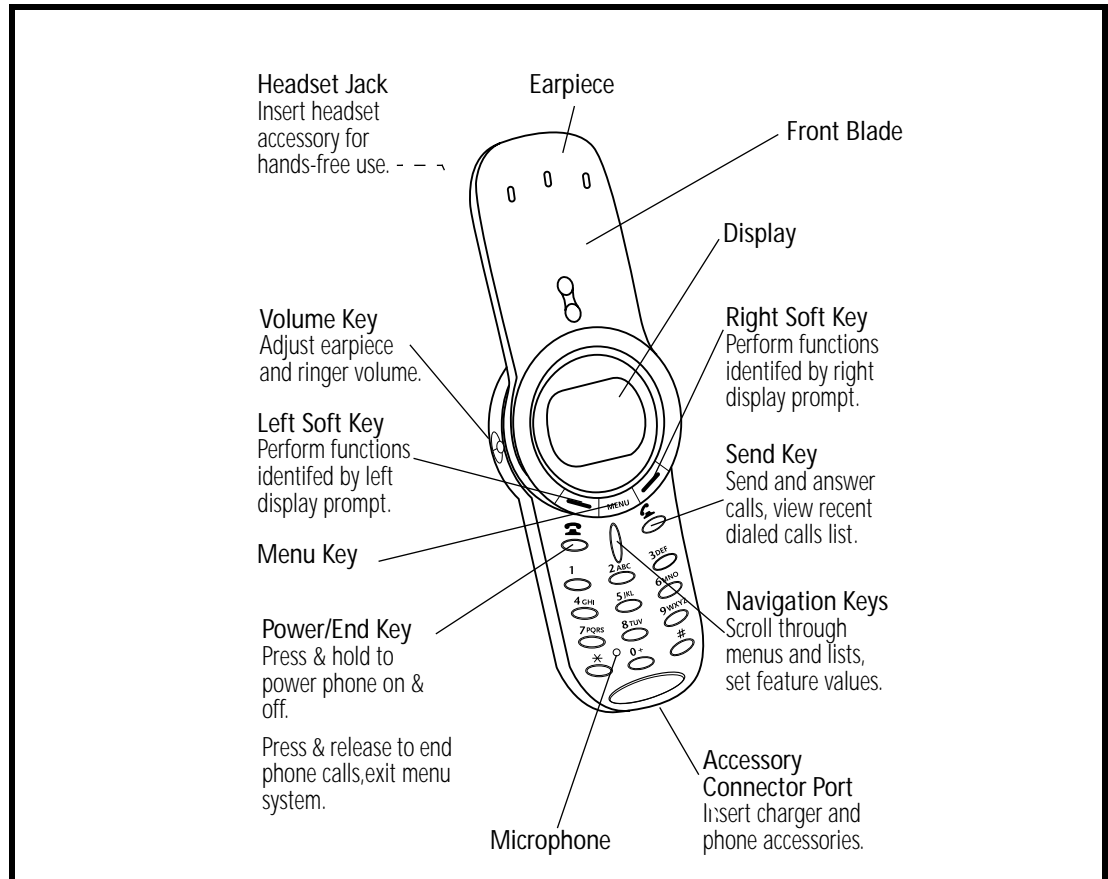

011211-0

Figure 1. PF C23 Telephone Controls and Indicators Locations

### Menu Navigation

PF C23 telephones are equipped with a simplified icon and list-based user interface. The phone also features a user-definable Quick Access menu that is accessed by holding down the MENU key. See Figure 3 for details of the PF C23 menu structure.

### Liquid Crystal Display (LCD)

The LCD provides an 800 square millimeter blue backlit display having user-adjustable contrast for optimum readability in all light conditions. The large bit-mapped 96 x 64 pixel display includes up to 3 lines of text, 1 line of icons, and 1 line of prompts.

Display animation makes the phone's icon menu move smoothly as the user scrolls up and down.



*Whether a phone displays all indicators depends on the programming and services to which the user subscribes.*

Figure 2 shows some common icons displayed on the LCD.

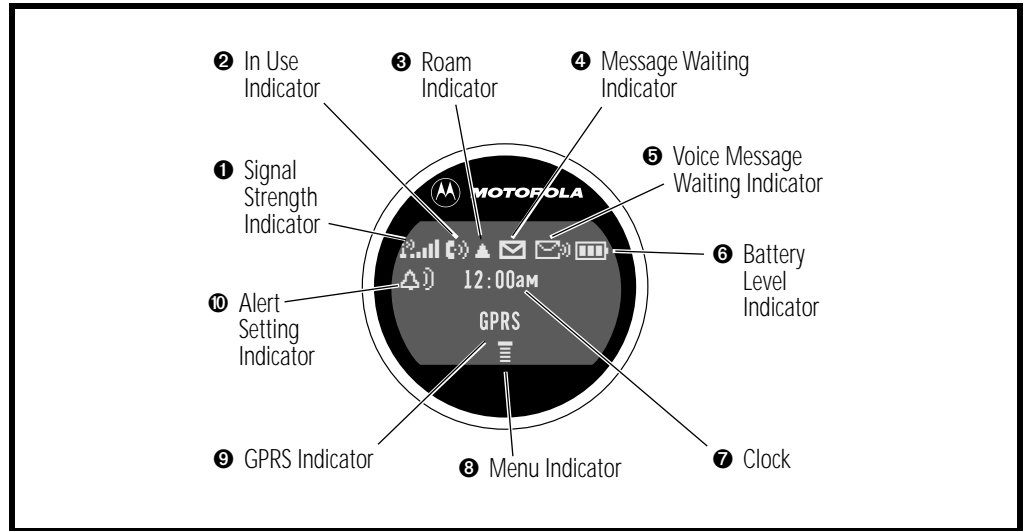

011212-o

**Figure 2. PF C23 Display Icon Indicators**

1. **Signal Strength** shows the strength of the phone's connection with the network. Calls cannot be sent or received when the "no signal" indicator is displayed.
2. **In Use Indicator** icon indicates a call in progress.
3. **Roam Indicator** icon appears when the phone uses another network system outside the user's home network. When leaving the home network area, the phone roams, or seeks, another network.
4. **Message Waiting Indicator**<sup>4</sup> appears when the phone receives a text message.
5. **Voice Message Waiting Indicator**<sup>4</sup> icon indicates when the phone receives a voicemail message.
6. **Battery Level Indicator** shows the amount of charge left in the battery.
7. **Real Time Clock** shows the current time.
8. **Menu Indicator** provides access to the phone's main menu.
9. **GPRS Indicator**<sup>4</sup> indicates when the phone is currently functioning in GPRS mode.
10. **Alert Setting Indicator** indicates the phone's current ringer alert setting.

4. Network, subscription and SIM card or service provider dependent feature. Not available in all areas.

## User Interface Menu Structure

Figure 3 shows the PF C23 telephone menu structure.

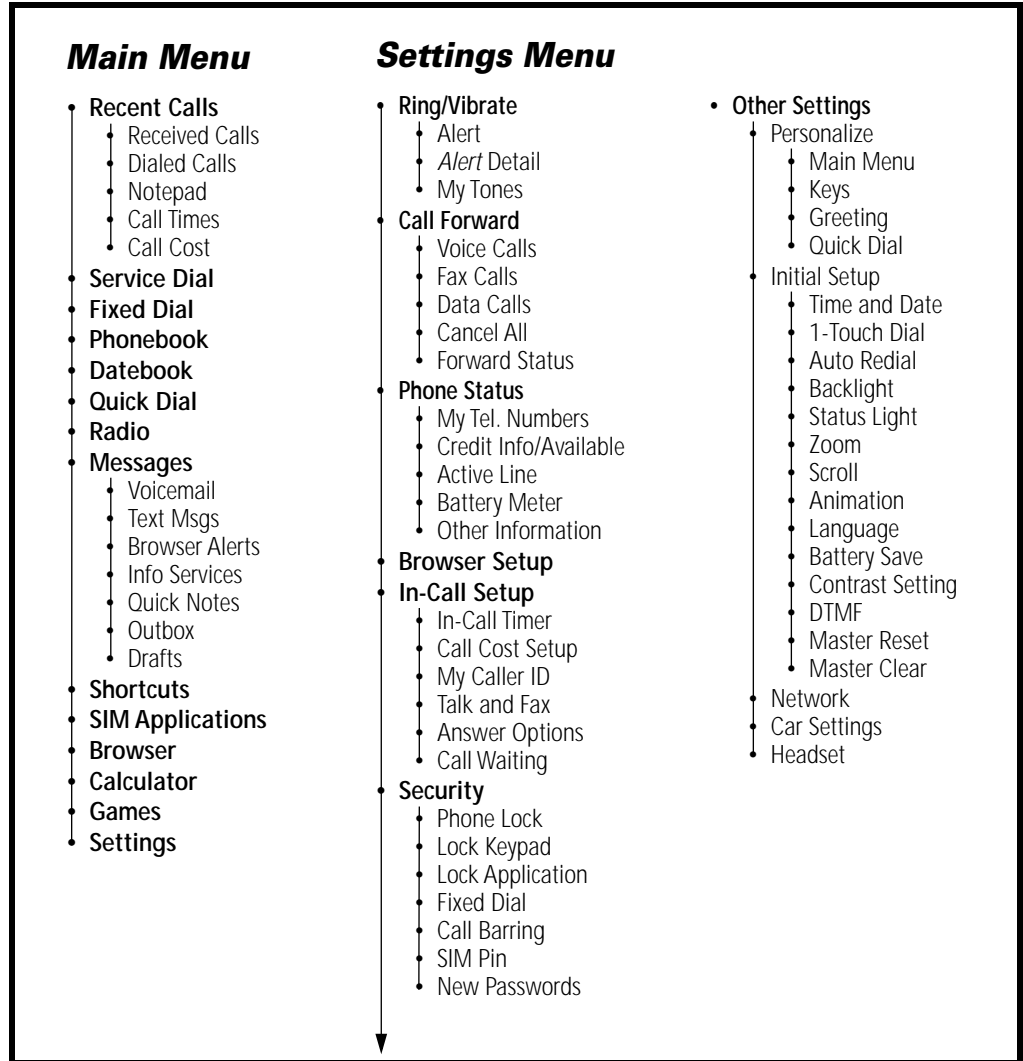

011564-o

Figure 3. PF C23 Menu Structure

## Alert Settings

In addition to 11 preset ring tones, PF C23 telephones allow the user to download 2 additional ring tones via SMS. (Availability is carrier and network dependant).

Motorola PF C23 phones incorporate the VibraCall® discreet vibrating alert that helps to avoid disturbing others when a ringing phone is unacceptable.

Alerts can be set to ring only, vibrate only, vibrate then ring, or no ring or vibrate

Additionally, the profiling feature allows users to identify incoming calls by a specific ringer tone.



---

## Battery Function

### Battery Charge Indicator

The telephone displays a battery charge indicator icon in the idle screen to indicate the battery charge level. The gauge shows four levels: 100%, 66%, 33%, and Low Battery.

### Battery Removal

Removing the battery causes the device to immediately shut down and any pending work (partially entered phone book entries or outgoing messages, for example) is lost.



*All batteries can cause property damage and / or bodily injury such as burns if a conductive material such as jewelry, keys, or beaded chains touch exposed terminals. The conductive material may complete an electrical circuit (short circuit) and become quite hot. Exercise care in handling any charged battery, particularly when placing it inside a pocket, purse, or other container with metal objects.*



*If the battery is removed while receiving a message, the message will be lost.*



*To ensure proper memory retention, turn the phone OFF before removing the battery. Immediately replace the old battery with a fresh battery.*

## Operation

For detailed operating instructions, refer to the appropriate user guide listed in the Related Publications section toward the end of this manual.



## Tools and Test Equipment

The following tables list the tools and test equipment used on PF C23 telephones. Use either the listed items or equivalents.

**Table 2. General Test Equipment and Tools**

Motorola Part Number <sup>1</sup>	Description	Application
See Table 7	Charger	Used to charge battery and to power device
0180386A82	Antistatic Mat Kit (includes 66-80387A95 antistatic mat, 66-80334B36 ground cord, and 42-80385A59 wrist band)	Provides protection from damage to device caused by electrostatic discharge (ESD)
8102430Z04	GSM / DCS / PCS Test SIM	Used to enable manual test mode
6680388B67	Disassembly tool, plastic with flat and pointed ends (manual opening tool)	Used during assembly/disassembly of device
6680388B01	Tweezers, plastic	Used during assembly/disassembly
RSX4043-A	Torque Driver	Used to remove and replace screws
—	Torque Driver Bit T-6 Plus, Apex 440-6IP Torx Plus or equivalent	Used with torque driver
HP34401A <sup>2</sup>	Digital Multimeter	Used to measure battery voltage

1. To order in North America, contact Motorola Aftermarket and Accessories Division (AAD) by phone at (800) 422-4210 or FAX (800) 622-6210; Internationally, AAD can be reached by calling (847) 538-8023 or faxing (847) 576-3023.

2. Not available from Motorola. To order, contact Hewlett Packard at (800) 452-4844.

---

## Disassembly

The procedures in this section provide instructions for the disassembly of a PF C23 telephone. Tools and equipment used are listed in Table 2, preceding.



*Many of the integrated devices used in this equipment are vulnerable to damage from electrostatic discharge (ESD). Ensure adequate static protection is in place when handling, shipping, and servicing the internal components of this equipment.*



*Avoid stressing the plastic in any way to avoid damage to either the plastic or internal components.*

## Removing and Replacing the Battery Cover and Battery



*All batteries can cause property damage and/or bodily injury such as burns if a conductive material such as jewelry, keys, or beaded chains touch exposed terminals. The conductive material may complete an electrical circuit (short circuit) and become quite hot. Exercise care in handling any charged battery, particularly when placing it inside a pocket, purse, or other container with metal objects.*

1. Ensure the front blade is closed and the phone is turned off.

2. While holding the battery cover release depressed, slide the battery cover release, slide the battery cover in the direction of the arrow, and lift completely off the phone (see Figure 4).

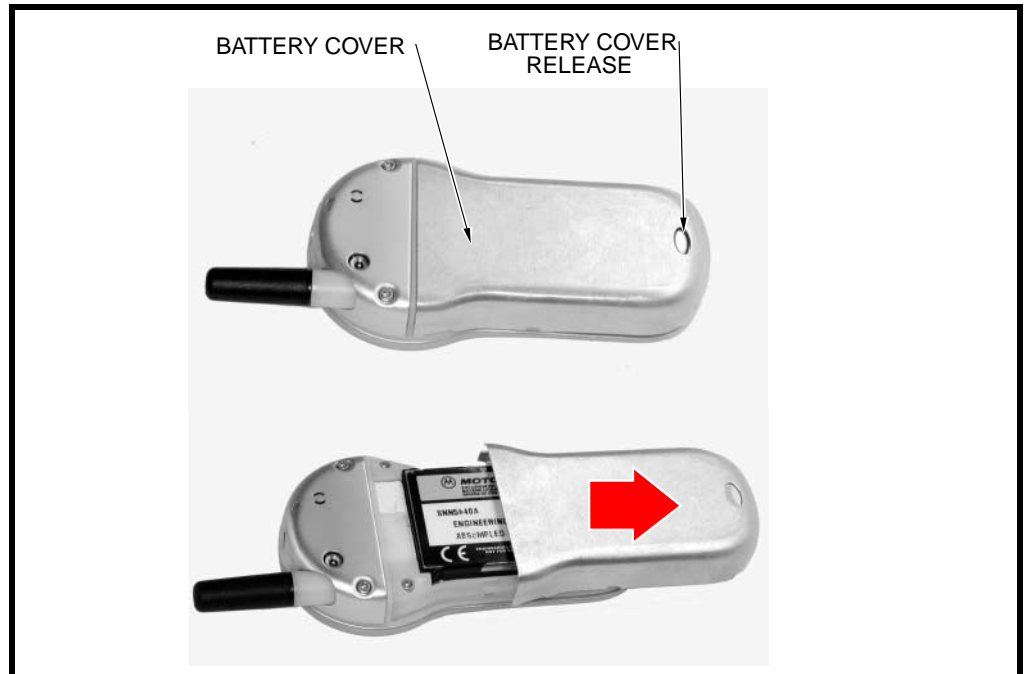

Figure 4. Removing the battery cover

011098-o

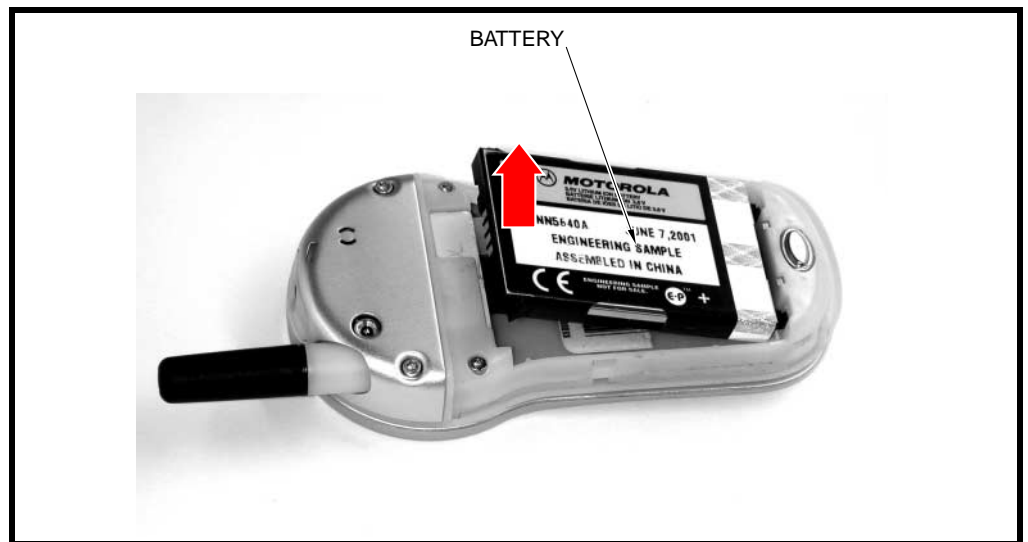

Figure 5. Removing the battery

011207-o

3. Remove the battery by lifting its top end from the battery compartment and sliding it up and away from the compartment as shown in Figure 5.



*There is a danger of explosion if the Lithium ion battery is replaced incorrectly. Replace only with the same type of battery or equivalent as recommended by the battery manufacturer. Dispose of used batteries according to the manufacturer's instructions.*

4. To replace, align the battery with the battery compartment so the terminals on the battery match the battery contacts in the phone.
5. Slide the bottom of the battery into the receptacle molded into the housing, then press the top end of the battery securely into the battery compartment.
6. Line up the battery cover with the rear housing then slide it forward until it snaps into place.

---

## Removing and Replacing the Subscriber Identity Module (SIM)

1. Remove the battery cover and battery as described in the procedures.
2. Remove the SIM by sliding it in the direction of the arrow as shown in Figure 6.

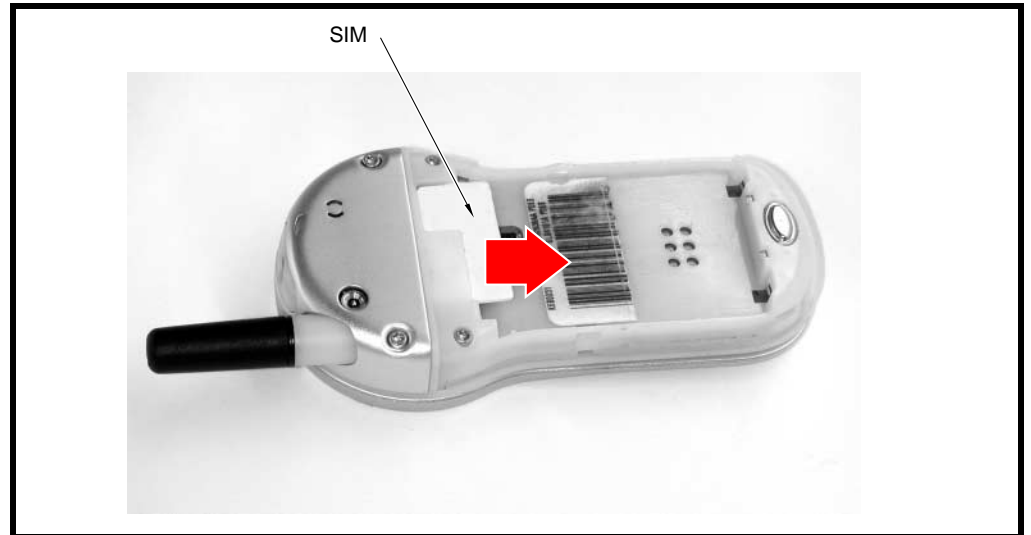

011099-o

**Figure 6. Removing the SIM**

3. To replace, carefully slide the SIM into its socket. Be sure the SIM is correctly positioned to contact the terminals in the phone.
4. Replace the battery and battery cover as described in the procedures.

## Removing and Replacing the Rear Housing Cover

1. Remove the battery cover, battery, and SIM as described in the procedures.
2. Using the Torx driver and T-6 bit, remove the 2 screws shown in Figure 7. Set the screws aside for reuse.
3. Slide the rear housing cover away from the unit and over the antenna until clear of the phone as shown in Figure 7.

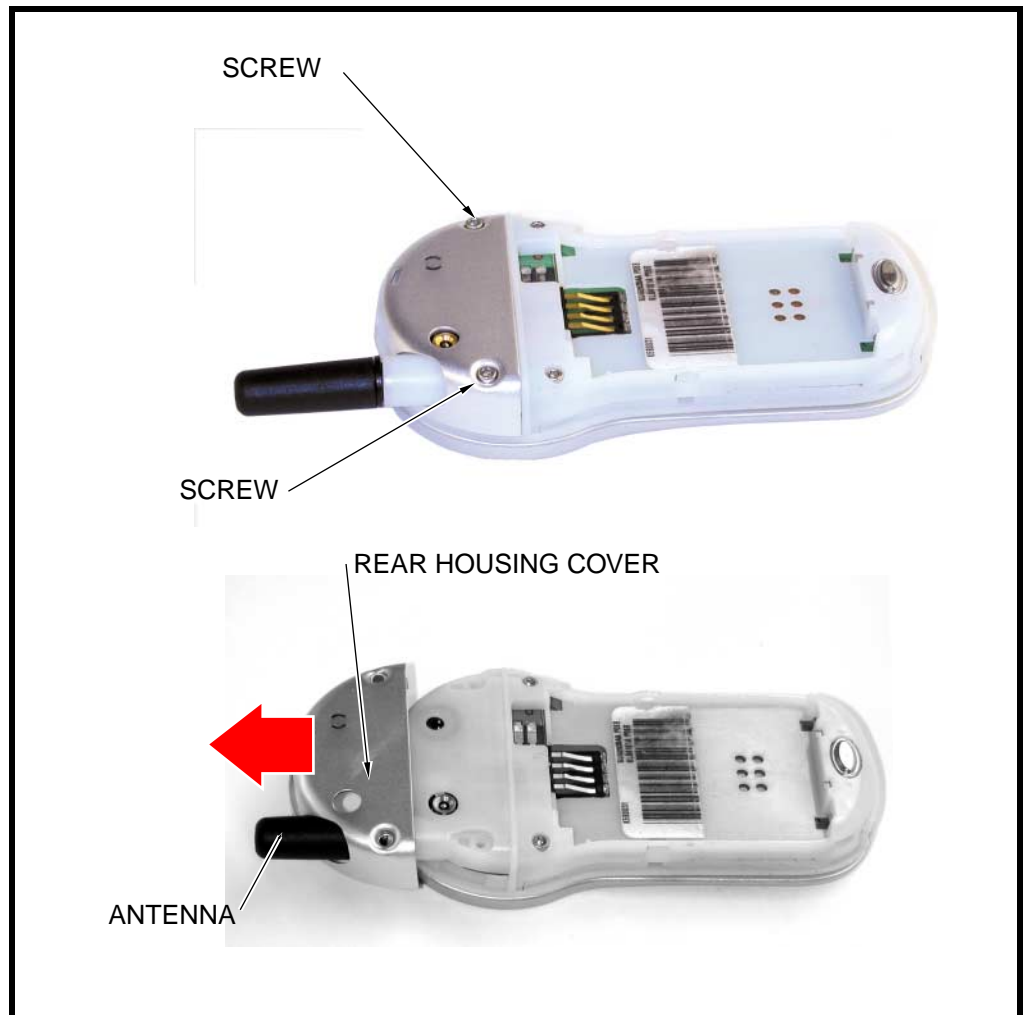

011100-o

**Figure 7. Removing the rear housing cover**

4. To replace, align the rear housing cover with the antenna and slide the cover over the antenna and onto the top of the phone.
5. Insert and tighten the 2 screws. Do not overtighten.
6. Replace the SIM, battery, and battery cover as described in the procedures.



## Removing and Replacing the Rear Transceiver Housing

1. Remove the battery cover, battery, SIM, and rear housing cover as described in the procedures.
2. Using the Torx driver and a T-6 bit, remove the two screws that secure the rear housing to the rear housing as shown in Figure 8.
3. Using the disassembly tool, disengage the six latches that secure the rear transceiver housing to the front transceiver housing as shown in Figure 8.
4. Carefully separate the rear transceiver housing from the front transceiver housing observing the volume button set into the side of the rear transceiver housing.

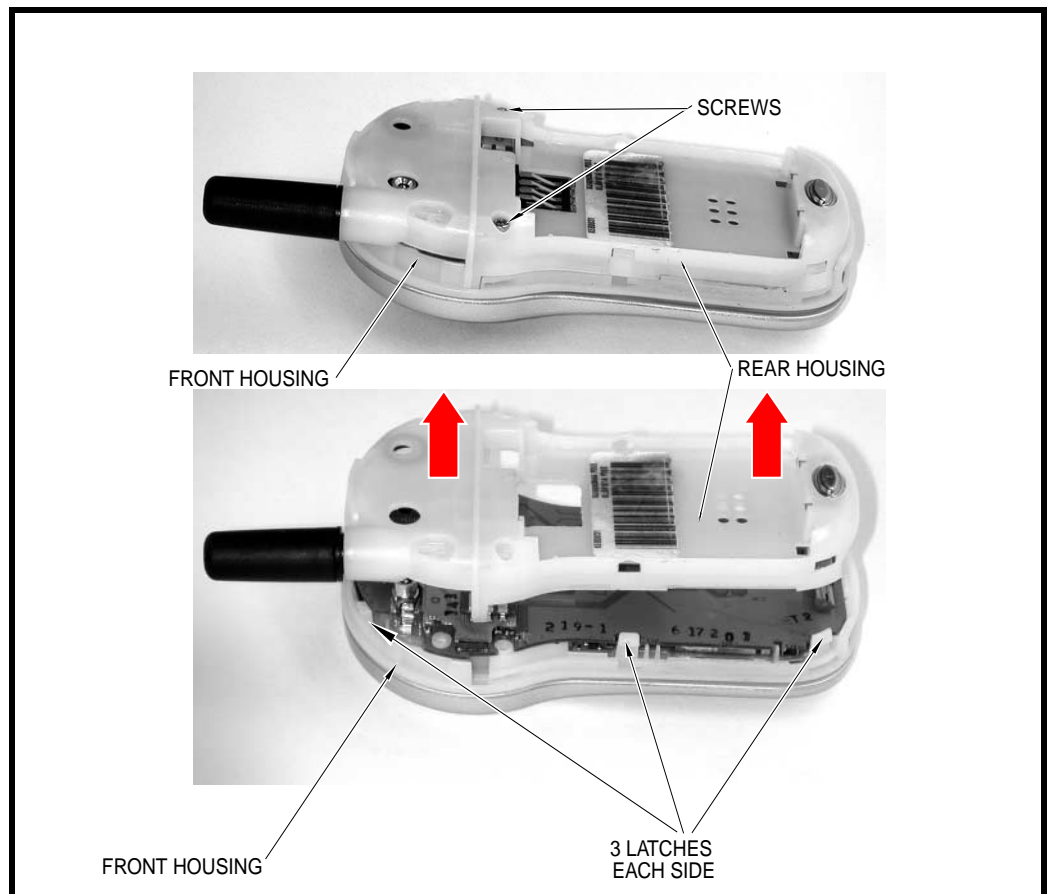
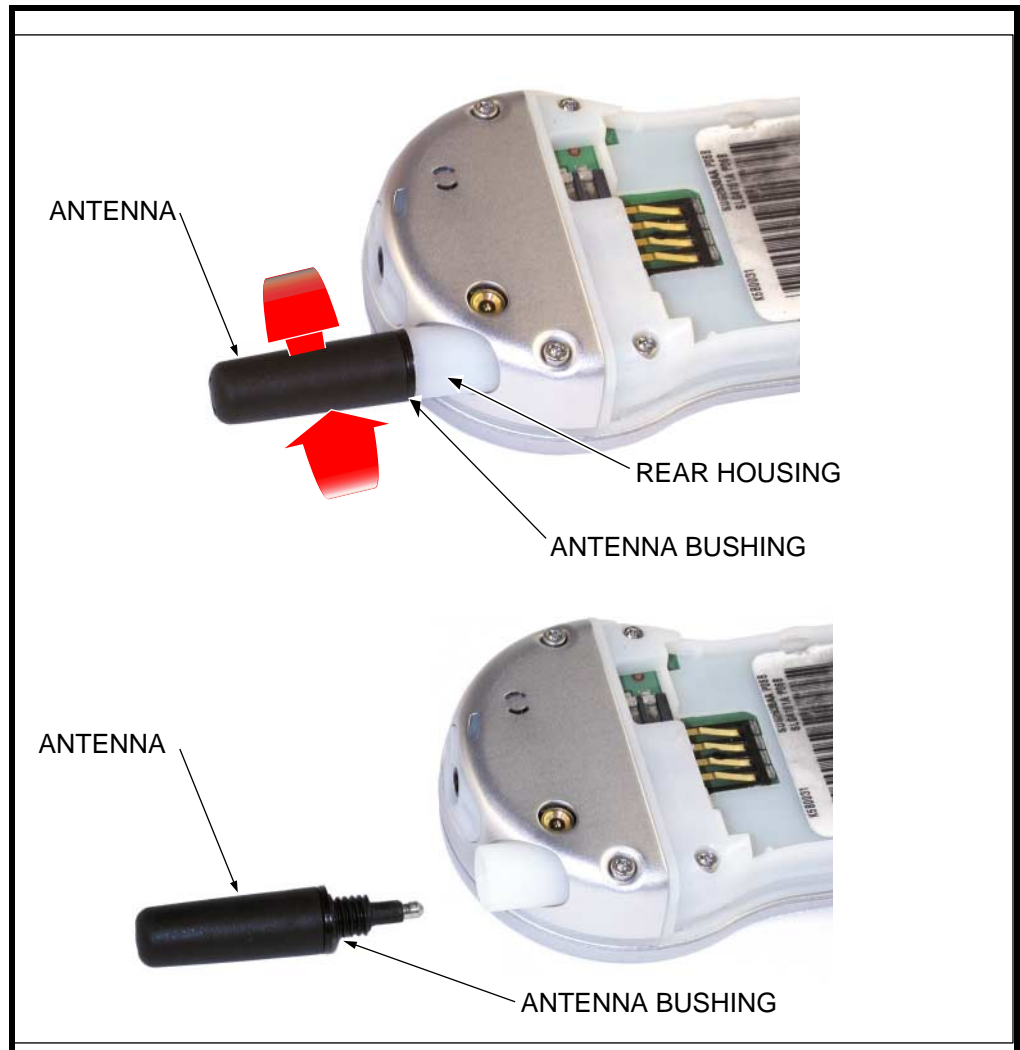

**Figure 8. Rear Transceiver Housing Removal**

5. To replace, align the rear transceiver housing with the front transceiver housing.
6. Carefully press the rear transceiver housing into the front transceiver housing until the six latches are engaged.
7. Operate the volume key to insure proper function.
8. Insert and tighten the 2 screws. Do not overtighten.
9. Replace the rear housing cover, the SIM, battery, and battery cover as described in the procedures.

## Removing and Replacing the Antenna

1. Remove the battery cover, and battery as described in the procedures.
2. Holding the rear housing in one hand, unscrew the antenna bushing from the rear housing by turning the antenna bushing in a counter-clockwise direction until the antenna and bushing are clear of the housing as shown in Figure 9.



011566-o

**Figure 9. Removing the Antenna**

3. To replace, align the antenna and bushing with the rear housing.
4. Screw the antenna and bushing into place until the antenna bushing is flush with the rear housing.
5. Replace the battery, and battery cover as described in the procedures.

## Removing and Replacing the Transceiver Board Assembly

1. Remove the battery cover, battery, SIM, rear housing cover, and rear transceiver housing as described in the procedures.



*This product contains static-sensitive devices. Use anti-static handling procedures to prevent electrostatic discharge (ESD) and component damage.*

2. Lift the end of the transceiver board out of the front transceiver housing as shown in Figure 10.

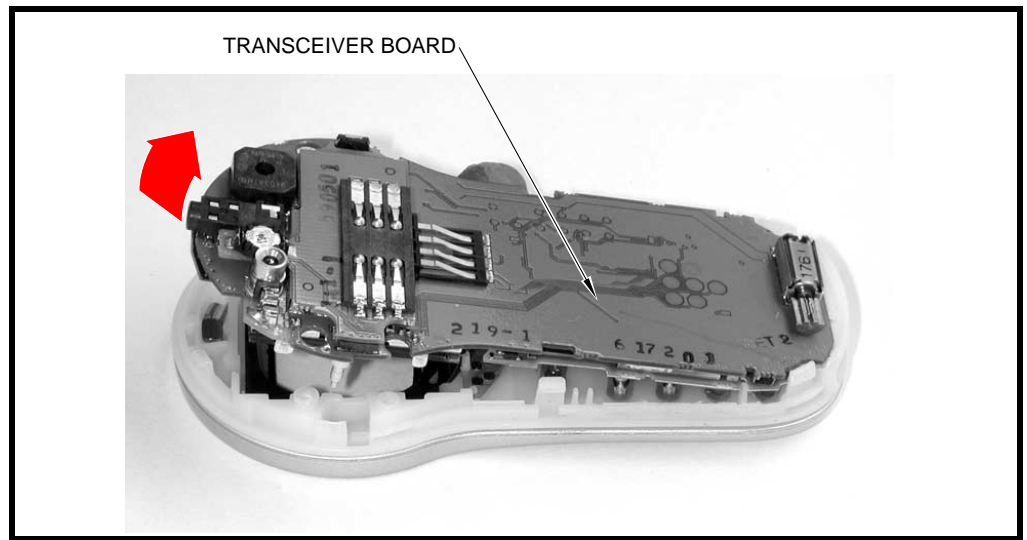

011102-o

**Figure 10. Removing the transceiver board assembly**

3. Gently slide the bottom end of the transceiver board out of the front transceiver housing. The transceiver board should separate easily from the front housing.
4. Lift the transceiver board assembly completely away from the rear housing.
5. To replace, align the bottom end of the transceiver board assembly with the rear housing and slide into place.
6. Replace the rear transceiver housing, rear housing cover, battery, SIM, and battery cover as described in the procedures.

## Removing and Replacing the Daughter PC Board

1. Remove the battery cover, battery, SIM, rear housing cover, rear transceiver housing, and transceiver board as described in the procedures.



*This product contains static-sensitive devices. Use anti-static handling procedures to prevent electrostatic discharge (ESD) and component damage.*

2. Using the disassembly tool, gently lift the daughter PC board out of its socket on the transceiver board as shown in Figure 11.

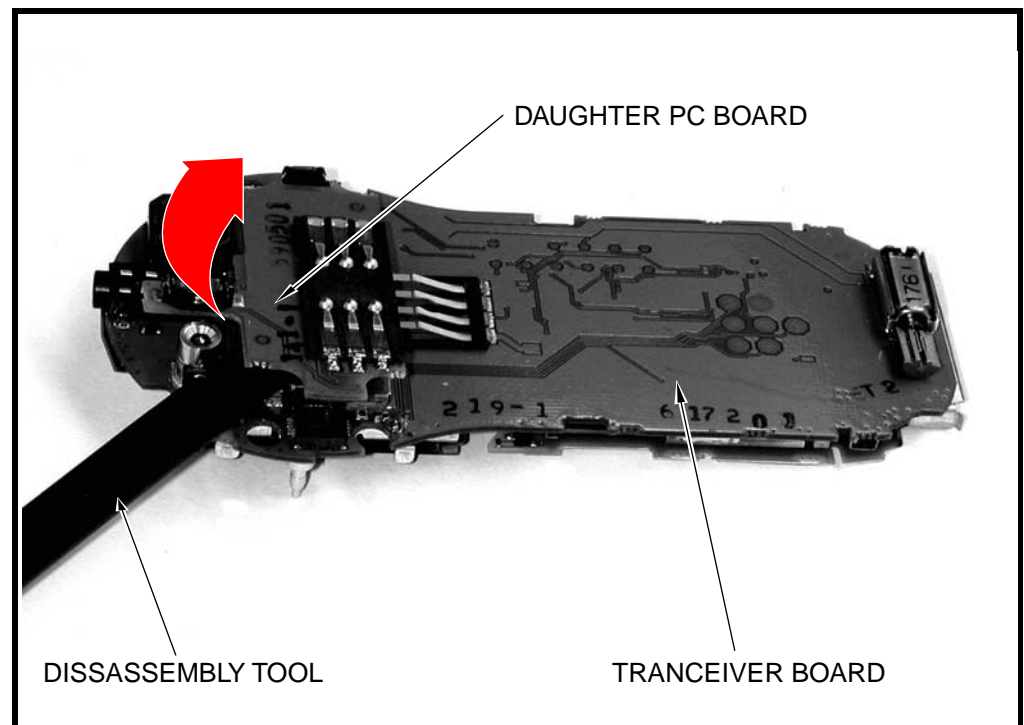

**Figure 11. Removing the Daughter PC board**

3. To replace, align the daughter PC board socket with its receptacle on the transceiver board.
4. Gently press the daughter PC board into its socket on the transceiver board.
5. Replace the transceiver board, rear transceiver housing, rear housing cover, SIM, battery, and battery cover as described in the procedures.

## Removing and Replacing the Real Time Clock Battery

1. Remove the battery cover, battery, SIM, rear housing cover, rear transceiver housing, transceiver board, and daughter PC board as described in the procedures.



*This product contains static-sensitive devices. Use anti-static handling procedures to prevent electrostatic discharge (ESD) and component damage.*

2. Using the plastic tweezers carefully lift the edge of the battery out of the battery holder as shown in Figure 12. Note the battery polarity before removing the battery from the battery holder.
3. Use the plastic tweezers to remove the battery from the battery holder.

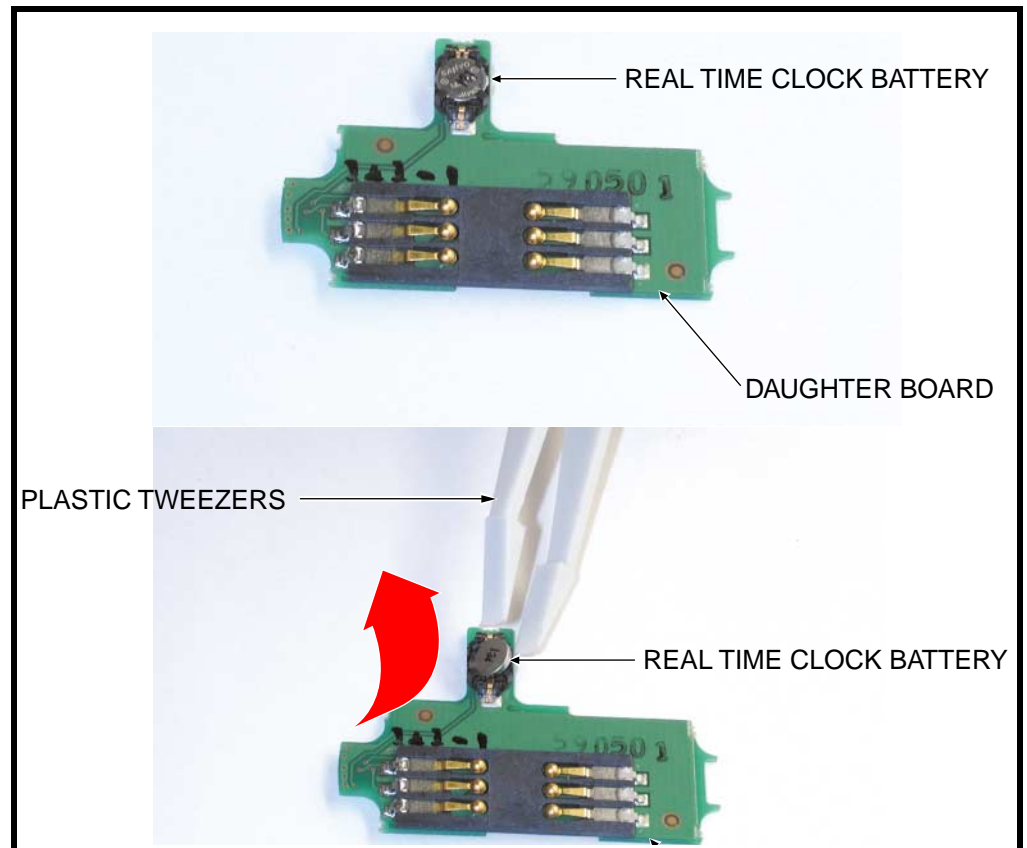
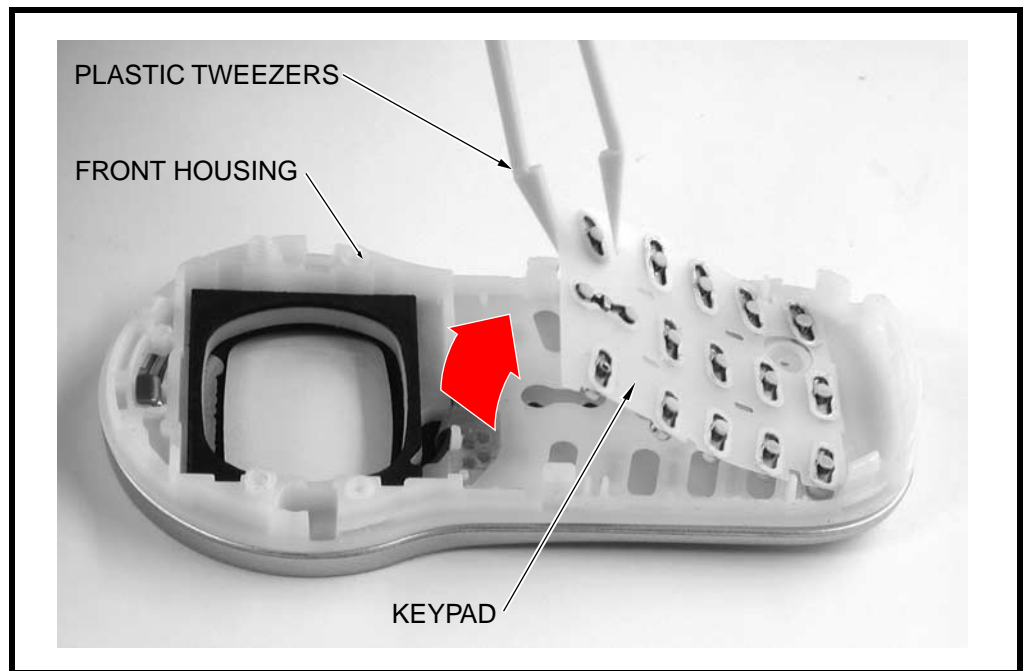

**Figure 12. Removing the Real Time Clock Battery**

4. To replace, place the real time clock battery over the battery holder. Ensure that the positive terminal (+) is facing up.
5. Using the plastic tweezers or the disassembly tool, press the battery down into the battery holder until it snaps into position.
6. Replace the daughterboard, transceiver board, rear transceiver housing, rear housing cover, SIM, battery, and battery cover.

## Removing and Replacing the Keypad

1. Remove the battery cover, battery, SIM, rear housing cover, rear transceiver housing, and transceiver board as described in the procedures.
2. Using the tweezers, lift the keypad away from the front transceiver housing as shown in Figure 13.



0111030

**Figure 13. Removing the keypad**

3. To replace, insert the keypad into the front housing. Ensure the keys align properly with the openings and the keypad is fully seated in the front housing
4. Replace the transceiver board, rear transceiver housing, rear housing cover, SIM, battery, and battery cover as described in the procedures.

## Removing and Replacing the Keypad PCB Assembly

1. Remove the battery cover, battery, SIM, rear housing cover, rear transceiver housing, and transceiver board as described in the procedures.

- Using the disassembly tool, gently lift the keypad PCB assembly out of its socket on the transceiver board assembly as shown in Figure 14.

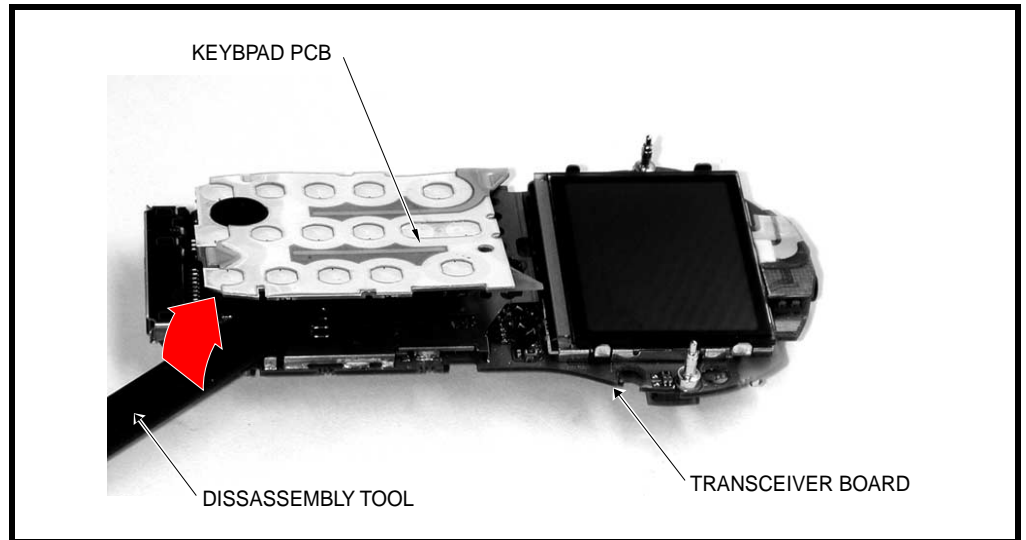

011104-o

**Figure 14. Removing Keypad PCB Assembly**

- To replace, align the Keypad PCB assembly with its socket on the transceiver board.
- Gently press the keypad PCB assembly onto the transceiver board assembly until it snaps into place.
- Replace the transceiver board, rear transceiver housing, rear housing cover, SIM, battery, and battery cover as described in the procedures.

## Removing and Replacing the Ring Bezel Assembly

1. Remove the battery cover, battery, SIM, and transceiver board assembly as described in the procedures.
2. Using the flat end of the disassembly tool, turn the ring bezel assembly a few millimeters in a counter-clockwise direction as shown in Figure 15.
3. Lift the ring bezel from the front blade housing.



*The ring bezel is reusable. Do not bend the catches permanently.*

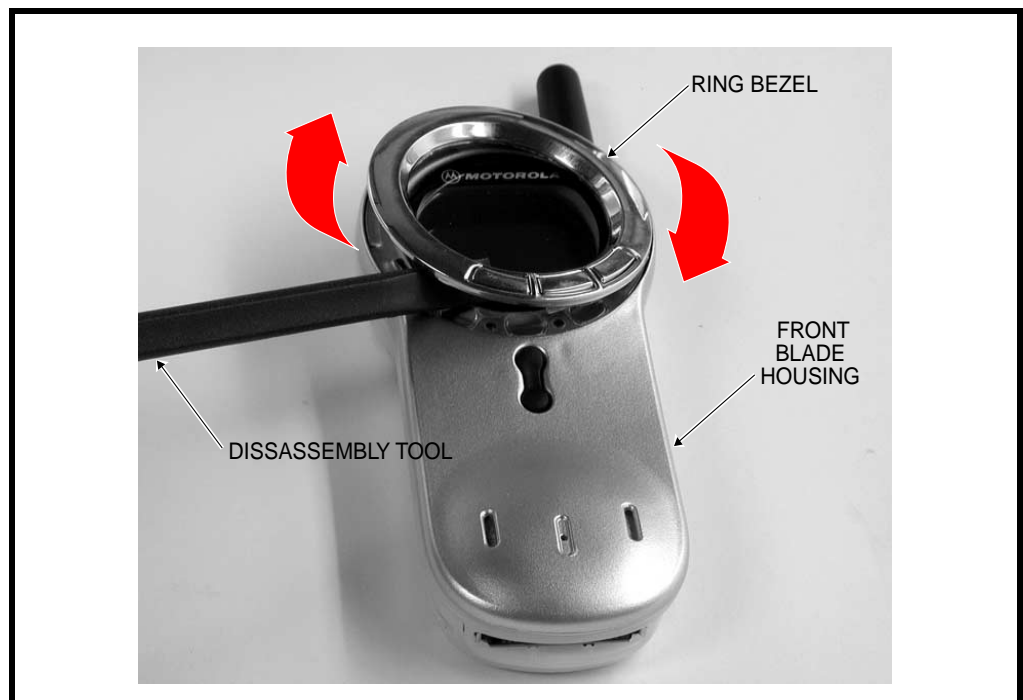

011105-0

**Figure 15. Removing the ring bezel assembly**

4. To replace, align the ring bezel assembly such that the middle key is just to the left of the volume up/down key as shown in Figure 15.
5. Using the flat end of the disassembly tool, turn the ring bezel assembly slightly in a clockwise motion until the ring bezel locks into place onto the front blade housing.
6. Replace the transceiver board assembly, SIM, battery, and battery cover as described in the procedures.



---

## Removing and Replacing the Display Module



*The flexible printed cable (FPC or flex) connecting the display module to the transceiver board is easily damaged. Exercise extreme care when handling.*

1. Remove the battery cover, battery, SIM, rear housing cover, rear transceiver housing and transceiver board as described in the procedures.
2. Using the flat end of the disassembly tool, carefully disconnect the flex connector from its socket on the transceiver board as shown in Figure 16.

- Using the flat end of the disassembly tool lift the display module from the transceiver board as shown in Figure 16.

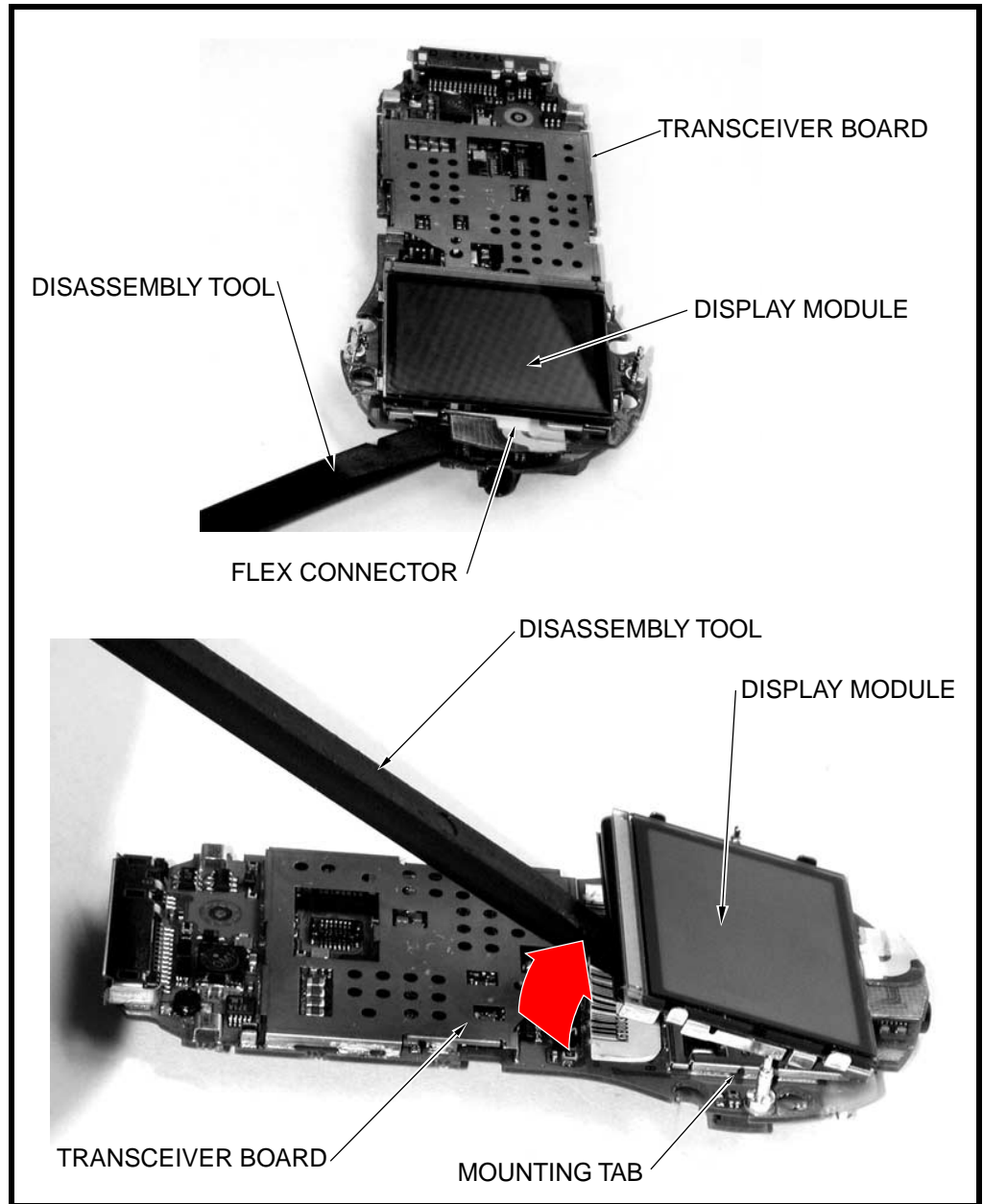

011106-o

**Figure 16. Removing the display module**

- To replace, insert the end of the display module flex into the connector on the transceiver board and press until the flex is fully seated in the connector.
- Line up the display module mounting tabs with the corresponding notches in the transceiver board, then press together until the display module snaps into place.

6. Replace the cover plate, transceiver board assembly, front cover, battery, and battery cover as described in the procedures.

## Removing and Replacing the Microphone

1. Remove the battery cover, battery, rear housing cover, rear transceiver housing transceiver board, and keypad PCB assembly as described in the procedures.
2. Using the flat end of the disassembly tool, carefully press the microphone out of the keypad assembly PCB as shown in Figure 17. The microphone should come away easily.

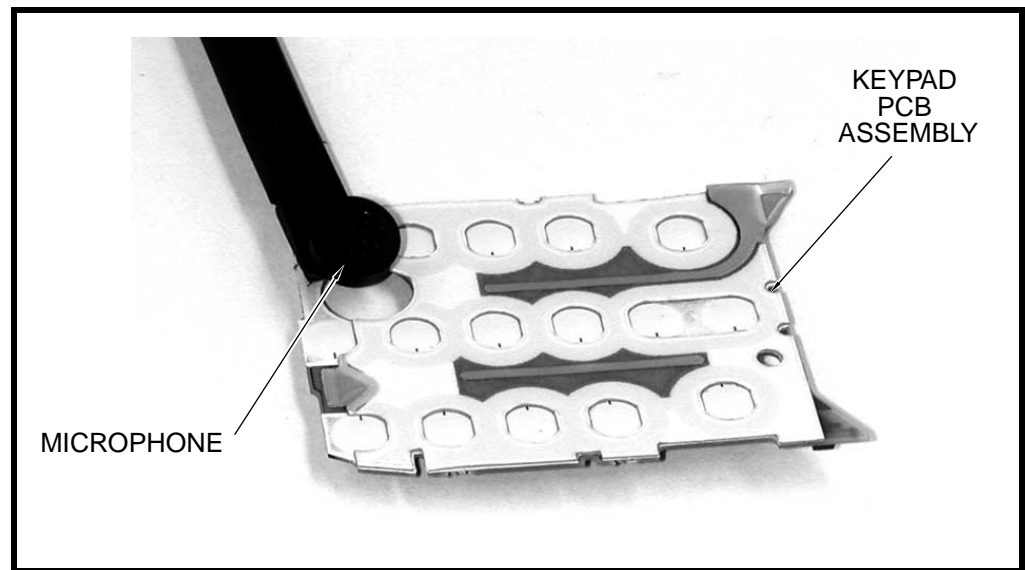

011208-o

**Figure 17. Removing the microphone**

3. To replace, align the microphone with the hole on the keypad PCB assembly and gently press straight down until fully seated.
4. Replace the keypad PCB assembly transceiver board assembly, front cover, battery, and battery cover as described in the procedures.

# Subscriber Identity Module (SIM) and Identification Label

## SIM

A SIM is required to access the existing local GSM network, or remote networks when traveling (if a roaming agreement has been made with the provider).

The SIM card contains:

- All the data necessary to access GSM services
- The ability to store user information such as phone numbers
- All information required by the network provider to provide access to the network

## Identification

Each Motorola GSM device is labeled with a variety of identifying numbers. The following information describes the current identifying labels.

### Mechanical Serial Number (MSN)

The Mechanical Serial Number (MSN) is an individual unit identity number and remains with the unit throughout its life.

The MSN can be used to log and track a unit on Motorola's Service Center Database.

The MSN is divided into 4 sections as shown in Figure 18.

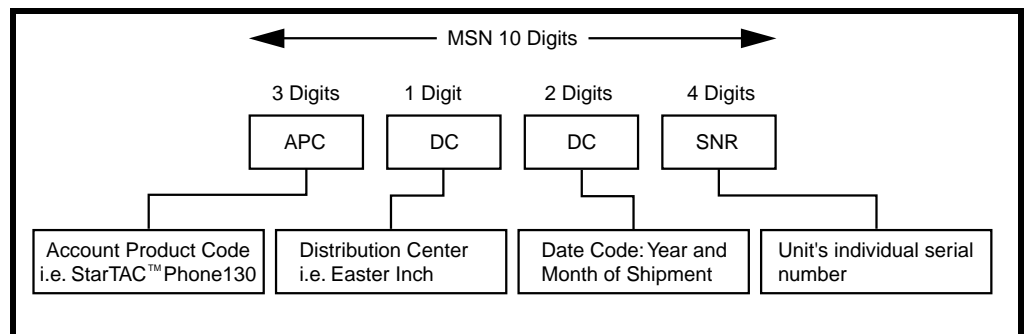

000807a

Figure 18. MSN label breakdown

## International Mobile Station Equipment Identity (IMEI)

The International Mobile station Equipment Identity (IMEI) number is an individual number unique to the PCB and is stored within the unit's memory. The following diagram illustrates the various parts of this number.

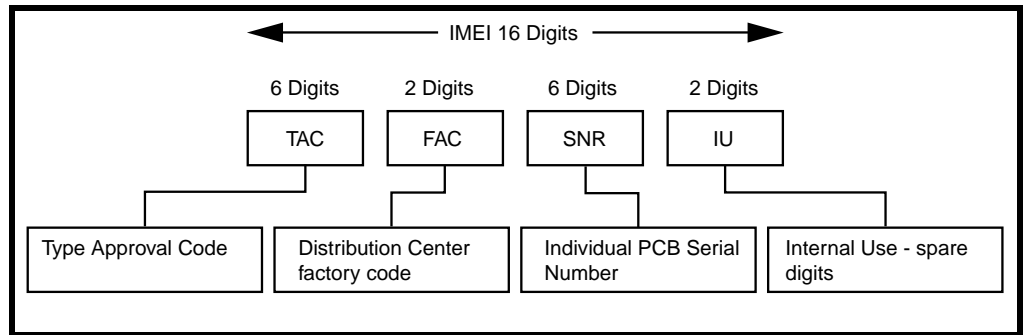

000808o

Figure 19. IMEI label breakdown

Other label number configurations present are:

- **TRANSCIVER NUMBER:** Identifies the product type. Normally the SWF number. (i.e. V100).
- **PACKAGE NUMBER:** Identifies the equipment type, mode, and language in which the product is shipped.

# Troubleshooting

## Manual Test Mode

Motorola PF C23 telephones are equipped with a manual test mode capability. This allows service personnel to verify functionality and perform fault isolation by entering keypad commands.

To enter the manual test command mode, a GSM / DCS test SIM must be used.

1. Press **Ⓞ** to turn the phone OFF.
2. Remove the battery as described in the procedures.
3. Remove the customer's SIM card from the phone as described in the procedures.
4. Insert the test SIM into the SIM slot.
5. Replace the battery as described in the procedures.
6. Press **Ⓞ** to turn the phone ON.

## Manual Test Mode Commands

**Table 3. Manual Test Commands**

Key Sequence	Test Function/Name	Remarks
<Menu>048263*	Enter manual test mode	
"End" Key	Exit manual test mode	
54*	Suspend	Required for all Test Mode Operations
0*0*0	Select tone 0	
0*0*1	Select tone 1	
0*0*2	Select tone 2	
0*0*3	Select tone 3	
0*0*4	Select tone 4	
0*0*5	Select tone 5	
0*0*6	Select tone 6	
0*0*7	Select tone 7	
0*0*8	Select tone 8	
0*0*9	Select tone 9	
0*1*X	Disable tone X	
3*0*1	Enable vibrator	
3*0*0	Disable vibrator	
5*0*0	Set audio level 0	
5*0*1	Set audio level 1	
5*0*2	Set audio level 2	
5*0*3	Set audio level 3	
5*0*4	Set audio level 4	
5*0*5	Set audio level 5	
5*0*6	Set audio level 6	
5*0*7	Set audio level 7	

**Table 3. Manual Test Commands (Continued)**

Key Sequence	Test Function/Name	Remarks
5*0*8	Set audio level 8	
5*0*9	Set audio level 9	
5*0*10	Set audio level 10	
5*0*11	Set audio level 11	
5*0*12	Set audio level 12	
5*0*13	Set audio level 13	
5*0*14	Set audio level 14	
5*0*15	Set audio level 15	
6*2*2*0*0	Set Audio Path. Int Mic, IntSpk, RX unmute, TX unmute	
6*4*6*0*0	Set Audio Path. Boom Mic, Boom Spk, RX unmute, TX unmute	
10*0*3	Set band GSM 900	
10*0*4	Set band DCS 1800	
10*0*5	Set band PCS 1900	
10*0*6	Set dual band GSM 900 / 1800	
10*1*0	Read band	3= GSM 4= DCS 5= PCS 6 =GSM/DCS
18*0	Initialize non-volatile memory (Master Reset)	
18*1	Initialize Non-volatile memory (Master Clear)	
55*2*001	Test Display. All pixels ON	
55*2*000	Test Display. All pixels OFF	
55*2*002	Test Display. Checkerboard pattern A	
55*2*003	Test Display. Checkerboard pattern B	
55*2*004	Test Display. Border pixels ON	
*#06#	IMEI Check	No Test Mode Required
Phone Set up --> Phone Status --> Other Information	Flex Version / Technology / S-W Version / Readiness Status	No Test Mode Required



## Troubleshooting Chart

Table 4. PF C23 Telephone: Level 1 and 2 Troubleshooting Chart

SYMPTOM	PROBABLE CAUSE	VERIFICATION AND REMEDY
1. Telephone will not turn on or stay on.	a) Battery either discharged or defective.	Measure battery voltage across a 50 ohm (>1 Watt) load. If the battery voltage is <3.25 Vdc, recharge the battery using the appropriate battery charger. If the battery will not recharge, replace the battery. If battery is not at fault, proceed to b.
	b) Battery terminals open or misaligned.	Visually inspect the battery terminals on both the battery and the telephone. Realign and, if necessary, either replace the battery or refer to a Level 3 Service Center for battery connector replacement. If battery terminals are not at fault, proceed to c.
	c) Transceiver board assembly defective.	Remove the transceiver board assembly. Substitute a known good assembly and temporarily reassemble the unit. Depress the PWR button; if unit turns on and stays on, disconnect the dc power source and reassemble the telephone with the new transceiver board assembly. Verify that the fault has been cleared.
2. Telephone exhibits poor reception or erratic operation such as calls frequently dropping or weak or distorted audio.	a) Antenna defective	Check connection between the antenna and the transceiver board assembly. If the connection is OK, substitute a known good antenna. If the fault is still present, proceed to b.
	b) Transceiver board assembly defective.	Replace the transceiver board assembly (refer to 1c). Verify that the fault has been cleared and reassemble the unit with the new transceiver board assembly.
3. Display is erratic, or provides partial or no display.	a) Mating connections to or from transceiver board faulty.	Check general condition of flex and flex connector. If the flex and connector is good, check that the display assembly mounting tabs are fully engaged. If connector is not at fault, proceed to b.
	b) Transceiver board assembly defective.	Replace the transceiver board assembly (refer to 1c). Verify that the fault has been cleared and reassemble the unit with the new transceiver board assembly.
4. Incoming call alert transducer audio distorted or volume is too low.	Faulty transceiver board assembly.	Replace the transceiver board assembly (refer to 1c). Verify that the fault has been cleared and reassemble the unit with the new transceiver board assembly.
5. Telephone transmit audio is weak. (usually indicated by called parties complaining of difficulty in hearing voice).	a) Microphone defective.	Replace the microphone as described in the procedures. If fault is not cleared, proceed to b.
	b) Transceiver board assembly defective.	Replace the transceiver board assembly (refer to 1c). Verify that the fault has been cleared and reassemble the unit with the new transceiver board assembly.
6. Receive audio from earpiece speaker is weak or distorted.	a) Connections to or from transceiver board assembly defective.	Check connection from the earpiece to the transceiver board assembly. If connection is not at fault, proceed to b.

**Table 4. PF C23 Telephone: Level 1 and 2 Troubleshooting Chart (Continued)**

SYMPTOM	PROBABLE CAUSE	VERIFICATION AND REMEDY
	b) Earpiece speaker defective.	Temporarily replace the speaker assembly with a known good assembly. Ensure good connection. Place a call and verify improvement in earpiece audio. If fault is cleared, reassemble the phone with the good assembly. If fault is not cleared, proceed to c.
	c) Transceiver board assembly defective.	Replace the transceiver board assembly (refer to 1c). Verify that the fault has been cleared and reassemble with the new transceiver board assembly.
7. Telephone will not recognize or accept SIM card.	a) SIM card defective.	Check the SIM card contacts for dirt. Clean if necessary, and check if fault has been cleared. If the contacts are clean, insert a known good SIM card into the telephone. Power up the unit and confirm that the card has been accepted. If the fault no longer exists, replace the defective SIM card. If the SIM card is not at fault, proceed to b.
	b) Transceiver board assembly defective.	Replace the transceiver board assembly (refer to 1c). Verify that the fault has been cleared and reassemble the unit with the new transceiver board assembly.
8. Vibrator feature not functioning.	a) Vibrator defective.	Replace vibrator as described in the procedures. If the fault has not been cleared, proceed to b.
	b) Transceiver board assembly defective.	Replace the transceiver board assembly (refer to 1c). Verify that the fault has been cleared and reassemble the unit with the new transceiver board assembly.
9. Internal Charger not working.	Faulty charger circuit on transceiver board assembly.	Test a selection of batteries in the rear pocket of the desktop charger. Check LED display for the charging indications. If these are charging properly, then the internal charger is at fault. Replace the transceiver board assembly (refer to 1c). Verify that the fault has been cleared and reassemble the unit with the new transceiver board assembly.
10. No or weak audio when using headset.	a) Headset plug not pushed fully home.	Ensure the headset plug is fully seated in the jack.
	b) Faulty jack on transceiver board assembly.	Replace the transceiver board assembly (refer to 1c). Verify that the fault has been cleared and reassemble the unit with the new transceiver board assembly.

## Programming: Software Upgrade and Flexing

Contact your local technical support engineer for information about equipment and procedures for flashing and flexing.

---

## Part Number Charts

The following charts are provided as a reference for the parts associated with PF C23 telephones.

### Related Publications

Motorola V70 Wireless Phone User Guide (Complex Chinese)

6809437A60

### Exploded View Diagram

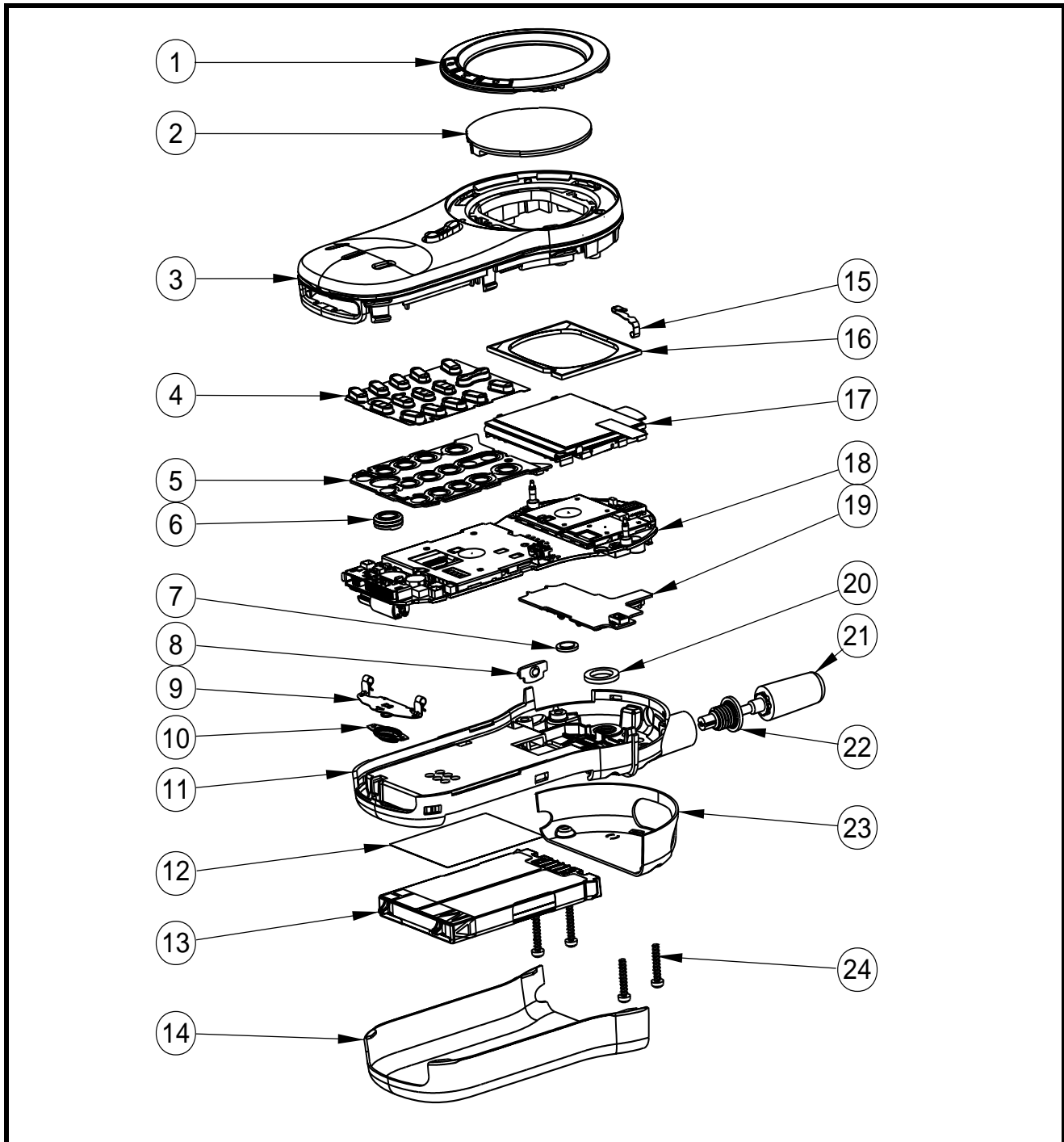

010973o

Figure 20. Exploded View Diagram

## Exploded View Parts List

Table 5. Exploded View Parts List

Item Number	Motorola Part Number	Description
1	3889291L01	Ring Bezel & Keys
2	6187762L01	Lens
3	See Table 6	Front blade housing assembly
4	3889174L01	Keypad
5	0188733L01	Keypad PCB assembly
6	5089725K01	Microphone
7	6087603L01	Real Time Clock Battery
8	3888445L01	Button, volume
9	0188468L02	Battery latch support
10	5588172L01	Battery latch button
11	See Table 6	Rear transceiver housing
12	SYN0326	Label SWF

Item Number	Motorola Part Number	Description
13	See Table 6	Battery
14	1587730L01	Battery cover
15	3989657L01	Ground clip
16	3287743L01	Display gasket
17	7287935L01	Display module
18	SUG2164	Main transceiver board
19	0189649L02	Daughter PC board
20	3288484L01	Alert gasket
21	See Table 6	Antenna
22	See Table 6	Threaded antenna insert
23	1587768L01	Rear housing cover
24	0387749L01	Screws

**Notes:**



*There is a danger of explosion if the Lithium ion battery pack is replaced incorrectly. Replace only with the same type of battery or equivalent as recommended by the battery manufacturer. Dispose of used batteries according to the manufacturer's instructions.*

To order parts please use the following Link:

[https://wissc.motorola.com/wissc\\_root/main/BrowserOK.html](https://wissc.motorola.com/wissc_root/main/BrowserOK.html)

(Password is Required)

For information on ordering parts please contact EMEA at +44 131 479 1274

## Model-Specific Part Numbers

**Table 6. Model-Specific Part Numbers**

Item Number	Part Description	Part Number
3	Blade assembly/Front transceiver housing, white, English	SHN8107
3	Blade assembly/Front transceiver housing, dark blue, English	SHN8108
3	Blade assembly/Front transceiver housing, light blue, English	SHN8109
3	Blade assembly/Front transceiver housing, white, PRC, simple Chinese	SHN8113
3	Blade assembly/Front transceiver housing, white, HK, simple Chinese	SHN8113
3	Blade assembly/Front transceiver housing, dark blue, PRC, simple Chinese	SHN8114
3	Blade assembly/Front transceiver housing, dark blue, HK, simple Chinese	SHN8114
3	Blade assembly/Front transceiver housing, light blue, PRC, simple Chinese	SHN8115
3	Blade assembly/Front transceiver housing, light blue, HK, simple Chinese	SHN8115
3	Blade assembly/Front transceiver housing, white, TWN, complex Chinese	SHN8119
3	Blade assembly/Front transceiver housing, dark blue, TWN, complex Chinese	SHN8120
3	Blade assembly/Front transceiver housing, light blue, TWN, complex Chinese	SHN8121
11	Rear transceiver housing, white	1587767L02
11	Rear transceiver housing, dark blue	1587767L03
11	Rear transceiver housing, light blue	1587767L04
21	Antenna, SUG2536AA, SUG2371AA, SUG2581AA, SUG2582AA, SUG2587AA, SUG2588AA, SUG2583AA, SUG2589AA	8587311M02
21	Antenna, SUG2370AA, SUG2584AA, SUG2585AA, SUG2586AA	8587311M01
22	Antenna insert, SUG2536AA, SUG2371AA, SUG2581AA, SUG2582AA, SUG2587AA, SUG2588AA, SUG2583AA, SUG2589AA	4389287L08
22	Antenna insert, SUG2370AA, SUG2584AA, SUG2585AA, SUG2586AA	4389287L07

## Accessories

**Table 7. List of Accessories**

Description	Part Number
Battery, 400 mAh Li Polymer	SNN5640
Battery 700 mAh Li Polymer	SNN5650
Travel Charger, Linear Wall Charger	SPN4808
Travel Charger, Linear Wall Charger, China	SPN4742
Travel Charger, Linear Wall Charger, Euro	SPN4734
Travel Charger, Linear Wall Charger, U.K.	SPN4745
Travel Charger, Mid-Rate Charger, w/U.S. flip	SPN4940
Travel Charger, Mid-Rate Charger, Korea	SPN4744
Travel Charger, Mid-Rate Charger, Hong Kong	SPN4756
Travel Charger, Rapid Wall Charger, w/U.S. flip	SPN4716
Travel Charger, Rapid Wall Charger, Hong Kong	SPN4737
Travel Charger, Rapid Wall Charger, Korea	SPN4736
Desktop Charger	SPN4997
Desktop Charger Insert	SHN8039
USB Data Kit	S8951
RS232 Data Kit	S8952
RS232 Data Kit for Palm III / V	S8953
Bluetooth PC Card	SYN6154
Bluetooth USB Adapter for PC	SKN6154
Easy Install Car Kit	SYN8597
Easy Install Car Kit	SYN9169
Vehicle Power Adapter	SYN7818
Headset, Silver Earbud	AAYN4264
Headset, Boom	SYN8146
Headset, Retractable	SYN8284
Headset, with Send/End	SYN8419
Headset, FM Stereo Radio	SYN8609
MP3 Player (CE Bus)	SYN8692





---

## Index

### A

alert settings 12  
antenna, removing and replacing 22

### B

battery  
    charge indicator 13  
    function 13  
battery cover, removing and replacing 16  
battery, removing and replacing 16

### C

caller ID 9  
Canadian Interference-Causing Equipment regulations 1  
changes  
    product 1  
commands, manual test mode 35  
copyrights  
    computer software 2  
cover plate, removing and replacing 28

### D

daughter PC board, removing and replacing 24  
disassembly 16  
display flex, disconnecting 29  
display module, removing and replacing 29

### E

exploded view diagram 40  
exploded view parts list 41

### F

FCC rules 1  
features  
    caller ID 9  
    Personal Information Management 9  
    SIM Toolkit 9  
    text entry 9  
    voice recognition 8  
    Wireless Access Protocol (WAP) 8

### H

housing cover rear, removing and replacing 20

### I

identification  
    international mobile station equipment identity 34  
    mechanical serial number 33  
    product 1  
identification, labels 33  
IMEI 34  
Introduction 1

### K

keypad, removing and replacing 26

### L

LCD 10  
liquid crystal display (LCD) 10

### M

manual test mode 35  
menu structure 12  
microphone, removing and replacing 32  
model-specific part numbers 42  
MSN 33

### N

names  
    product 1

### O

operation 10  
    alert settings 12  
    battery 13  
    controls, indicators, and I/O connectors 10  
    icons 11  
        Alert Setting Indicator 11  
        battery charge indicator 11  
        GPRS Indicator 11  
        In Use Indicator 11  
        Menu Indicator 11  
        message 11  
        message waiting indicator 11  
        real time clock 11  
        roam indicator 11  
        signal strength 11  
        voice message waiting indicator 11  
        voicemail 11  
    LCD 10  
    menu navigation 10  
    menu structure 12

operations  
  icons  
    Battery Level Indicator 11  
overview, product 7

## P

parts  
  exploded view diagram 40  
  exploded view parts list 41  
  model-specific part numbers 42  
  replacement parts 39  
personal information management 9  
product  
  changes 1  
  identification 1  
  names 1  
product overview 7  
  features 7  
publications, related 39

## R

Real Time Clock Battery, removing and replacing 25  
rear housing cover, removing and replacing 20  
rear transceiver housing, removing and replacing 21  
regulatory agency compliance 1  
related publications 39  
removing  
  antenna 22  
  battery 13, 16  
  battery cover 16  
  cover plate 28  
  daughter PC board 24  
  display module 29  
  keypad 26  
  microphone 32  
  Real Time Clock Battery 25  
  rear housing cover 20  
  rear transceiver housing 21  
  SIM 19  
  transceiver board 23  
replacement parts  
  ordering 4  
replacing  
  antenna 22  
  battery 16  
  battery cover 16  
  cover plate 28  
  daughter PC board 24  
  display module 29  
  keypad 26

microphone 32  
Real Time Clock Battery 25  
rear housing cover 20  
rear transceiver housing 21  
SIM 19  
transceiver board 23  
revisions  
  service manual 3

## S

serial number  
  mechanical 33  
service manual  
  about 2  
  audience 2  
  conventions 3  
  revisions 3  
  scope 2  
service policy 3  
  customer support 4  
  out of box failure 3  
  product support 3  
shut down  
  upon battery removal 13  
SIM Toolkit 9  
SIM, description 33  
SIM, removing and replacing 19  
specifications 5  
subscriber identity module (SIM) 33  
support  
  customer 4  
  product 3

## T

test equipment 15  
text entry 9  
tools, disassembly 15  
transceiver board, removing and replacing 23  
troubleshooting 35  
  manual test mode 35  
  manual test mode commands 35  
  troubleshooting chart 37

## V

voice activation 8

## W

WAP (Wireless Access Protocol) 8  
warranty service 3



MOTOROLA, the Stylized M Logo, and all other trademarks indicated as such herein are trademarks of Motorola, Inc  
Truesync is a trademark of Starfish Software, Inc..

® Reg. U.S. Pat. & Tm. Off.

© 2002 Motorola, Inc.

All rights reserved.

Personal Communications Sector,

1500 Gateway Blvd.

Boynton Beach, FL 33426-8292

Printed in U.S.A. 1/02



6881039B25-O