

BENQ CONFIDENTIAL

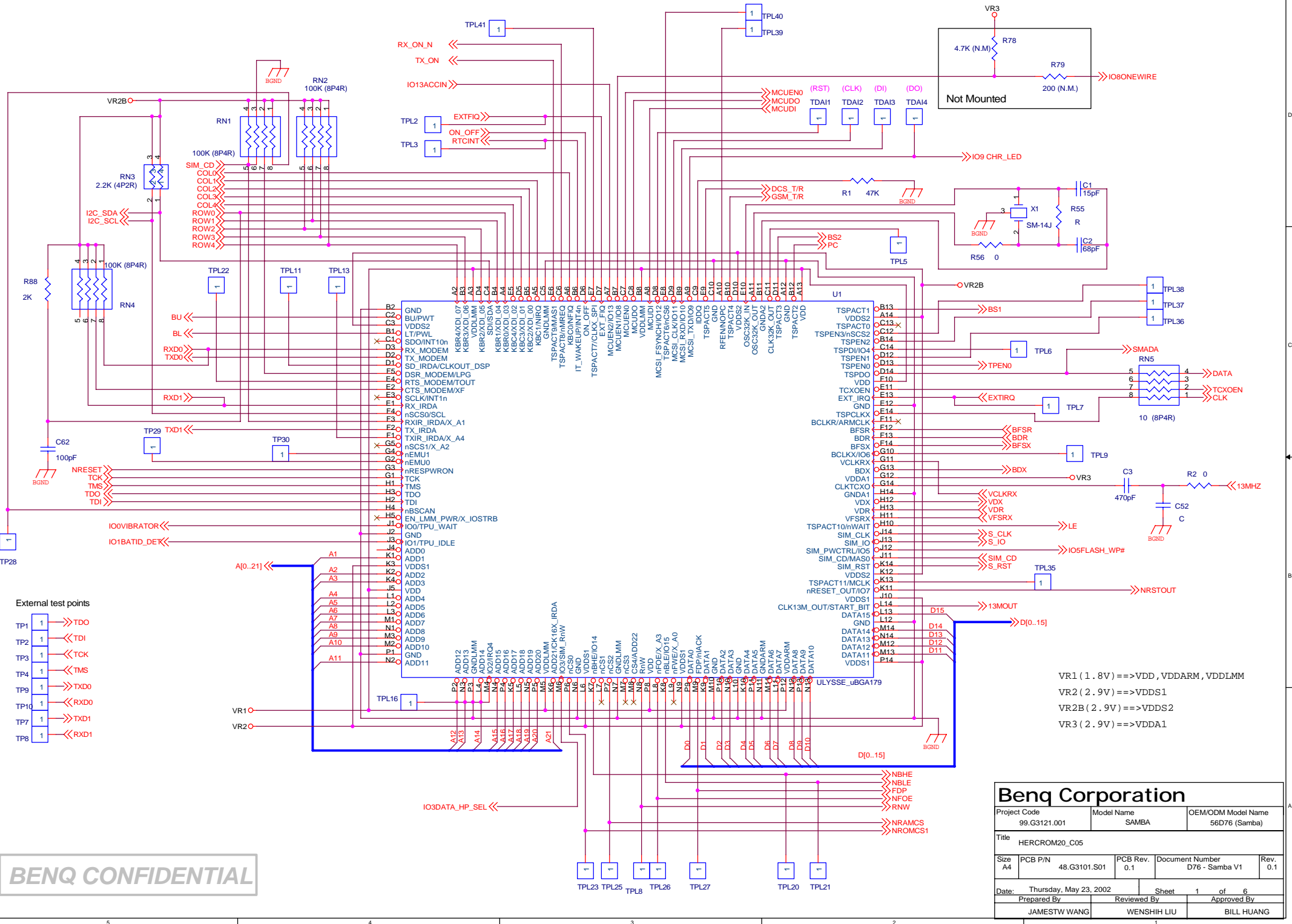

VR1 (1.8V) ==> VDD, VDDARM, VDDLMM
 VR2 (2.9V) ==> VDDSD1
 VR2B (2.9V) ==> VDDSD2
 VR3 (2.9V) ==> VDDA1

Benq Corporation			
Project Code	99.G3121.001	Model Name	SAMBA
OEM/ODM Model Name	56D76 (Samba)		
Title	HERCROM20_C05		
Size	A4	PCB P/N	48.G3101.S01
PCB Rev.	0.1	Document Number	D76 - Samba V1
Rev.	0.1		
Date:	Thursday, May 23, 2002	Sheet	1 of 6
Prepared By	JAMESTW WANG	Reviewed By	WENSHIH LIU
Approved By		Approved By	BILL HUANG

BENQ CONFIDENTIAL

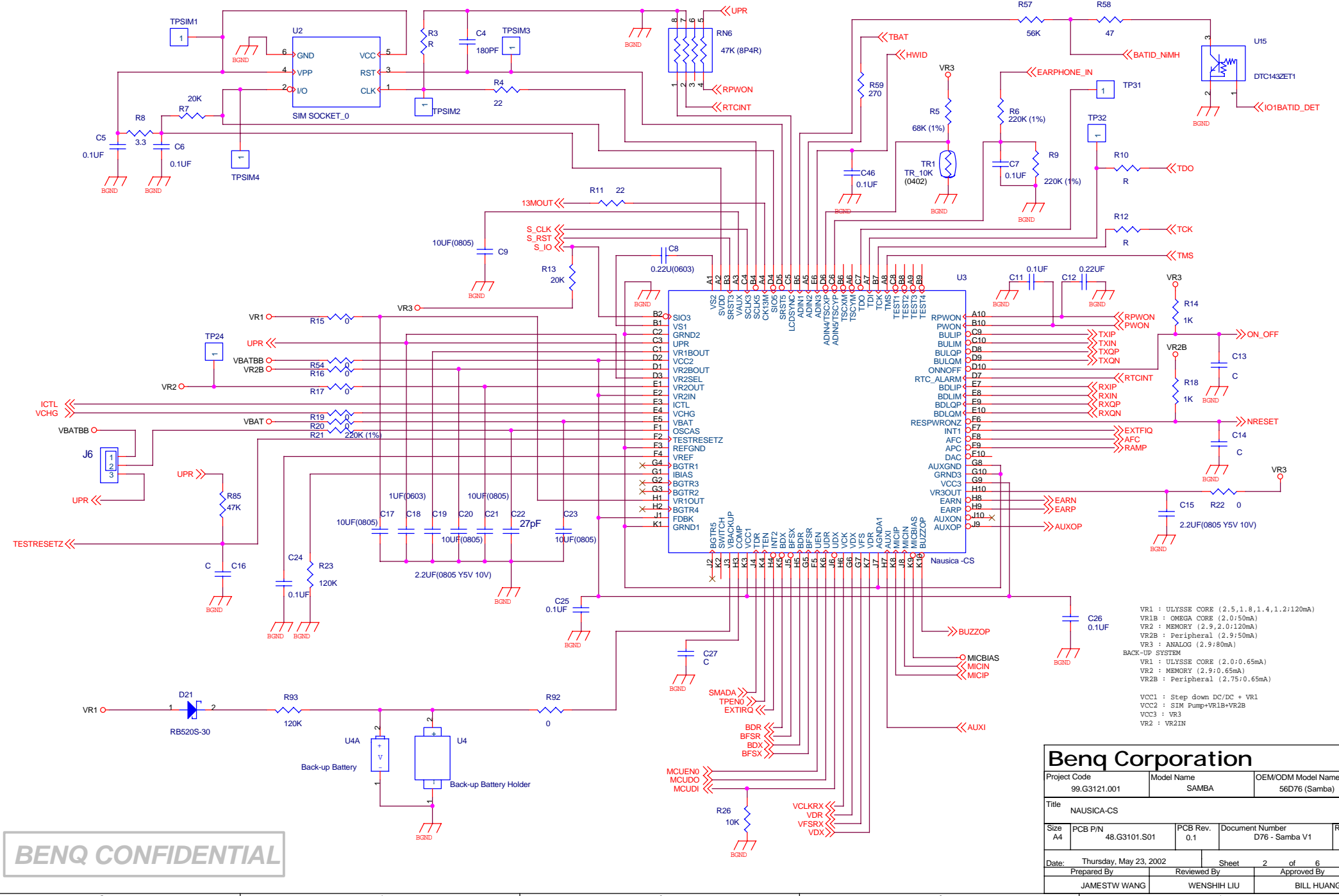

- VR1 : ULYSSE CORE (2.5;1.8;1.4;1.2;120mA)
 - VR1B : OMEGA CORE (2.0;50mA)
 - VR2 : MEMORY (2.9;2.0;120mA)
 - VR2B : Peripheral (2.9;50mA)
 - VR3 : ANALOG (2.9;80mA)
- BACK-UP SYSTEM
- VR1 : ULYSSE CORE (2.0;0.65mA)
 - VR2 : MEMORY (2.9;0.65mA)
 - VR2B : Peripheral (2.75;0.65mA)
- VCC1 : Step down DC/DC + VR1
VCC2 : SIM Pump+VR1B+VR2B
VCC3 : VR3
VR2 : VR2IN

Benq Corporation					
Project Code	99.G3121.001	Model Name	SAMBA	OEM/ODM Model Name	56D76 (Samba)
Title	NAUSICA-CS				
Size	A4	PCB P/N	48.G3101.S01	PCB Rev.	0.1
		Document Number	D76 - Samba V1	Rev.	0.1
Date:	Thursday, May 23, 2002		Sheet	2 of 6	
Prepared By	JAMESTW WANG	Reviewed By	WENSHIH LIU	Approved By	
				BILL HUANG	

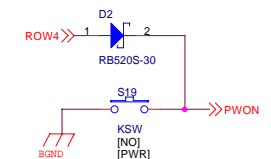
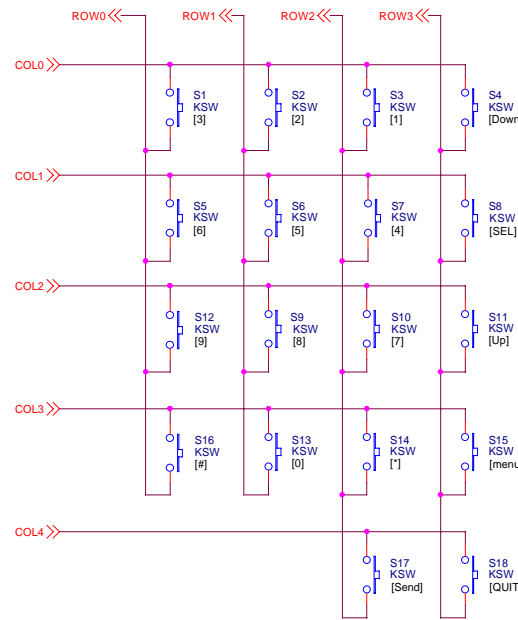
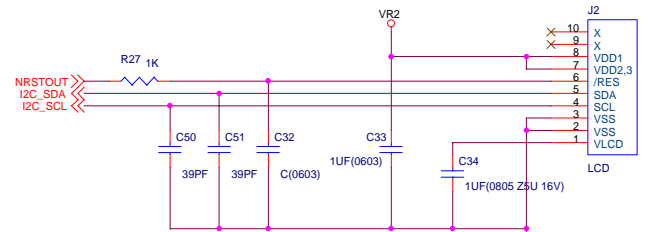
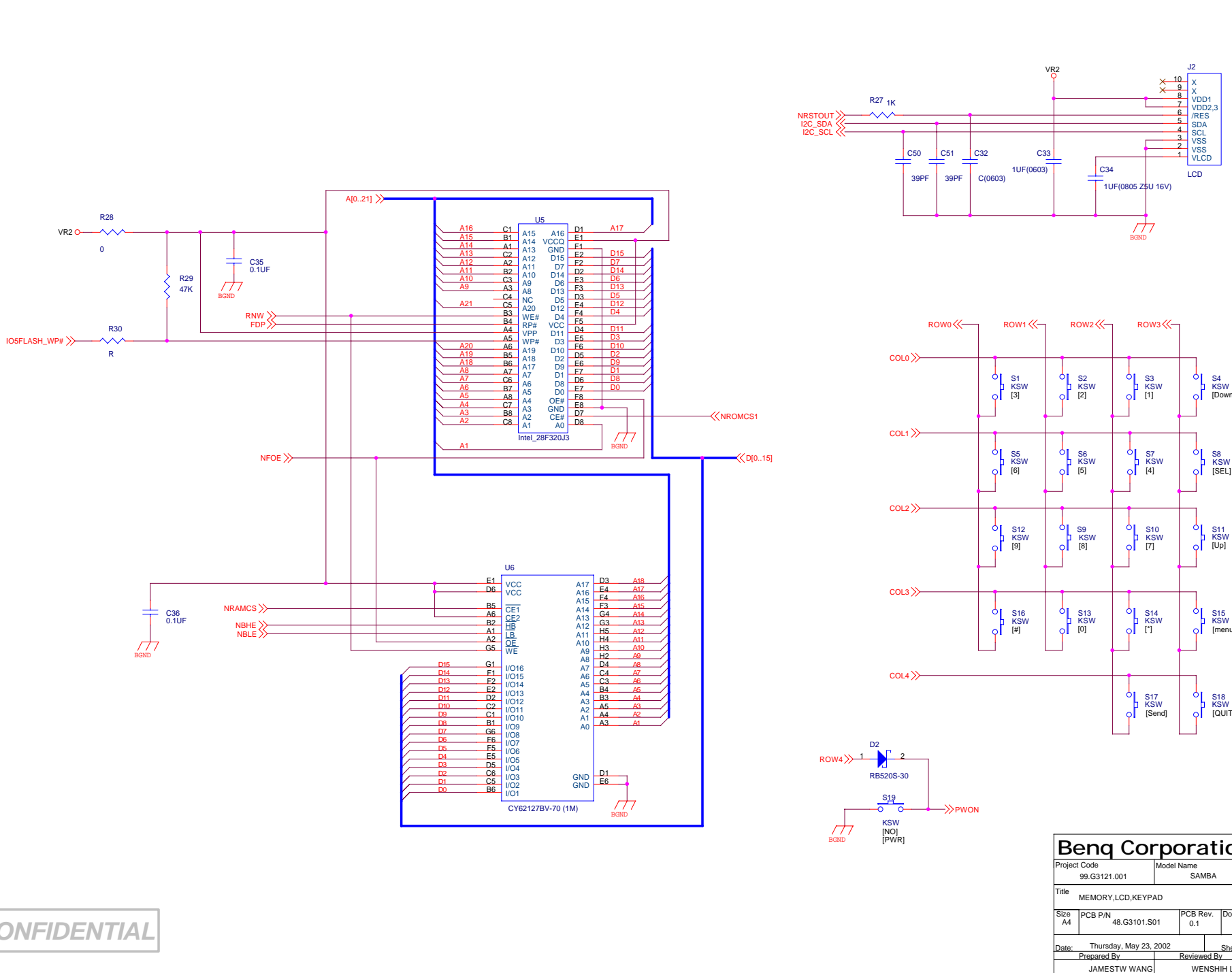

BENQ CONFIDENTIAL

Benq Corporation				
Project Code	Model Name	OEM/ODM Model Name		
99.G3121.001	SAMBA	56D76 (Samba)		
Title MEMORY.LCD.KEYPAD				
Size	PCB P/N	PCB Rev.	Document Number	Rev.
A4	48.G3101.S01	0.1	D76 - Samba V1	0.1
Date: Thursday, May 23, 2002		Sheet 3 of 6		
Prepared By		Reviewed By		Approved By
JAMESTW WANG		WENSHIH LIU		BILL HUANG

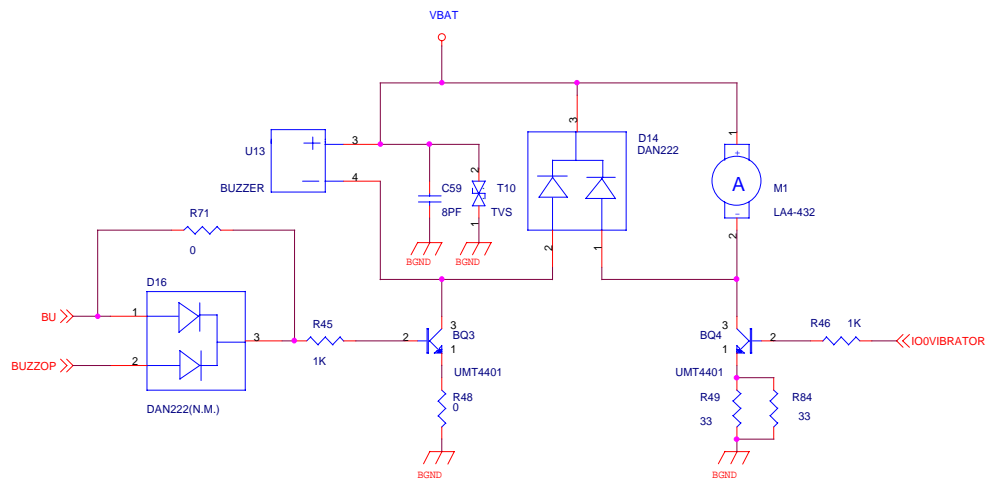
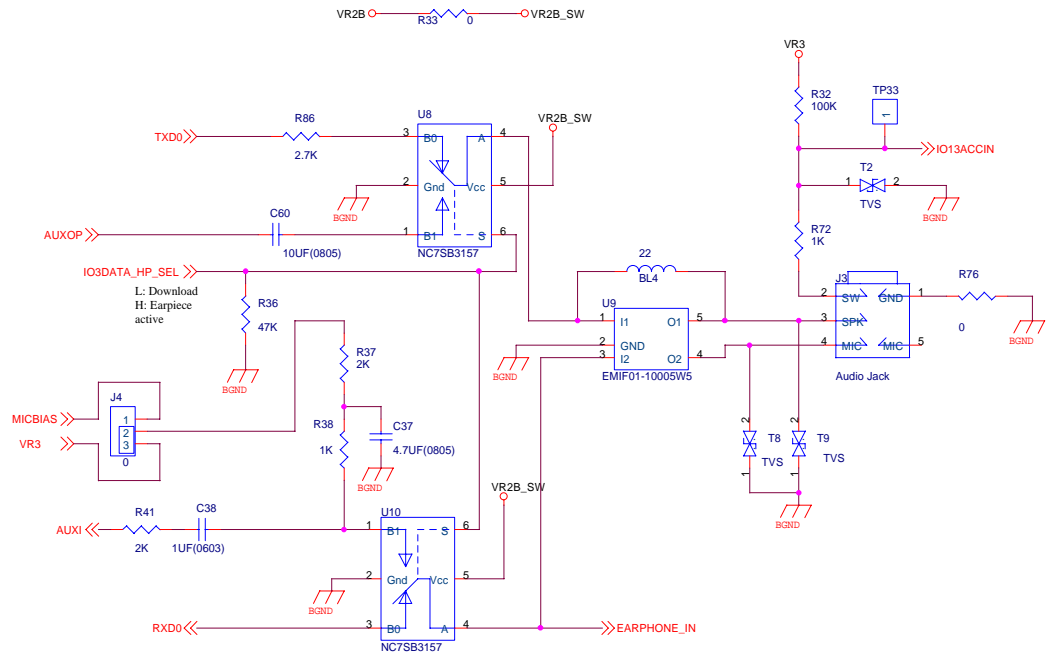
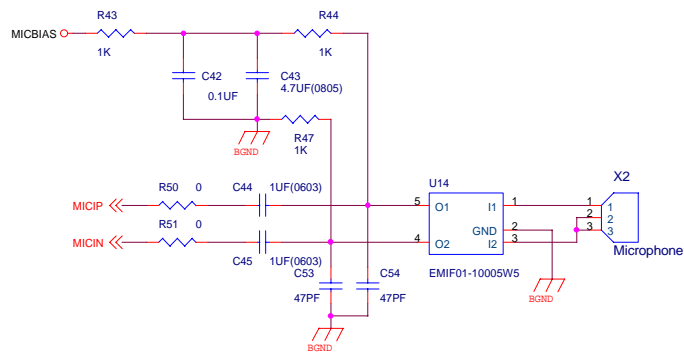
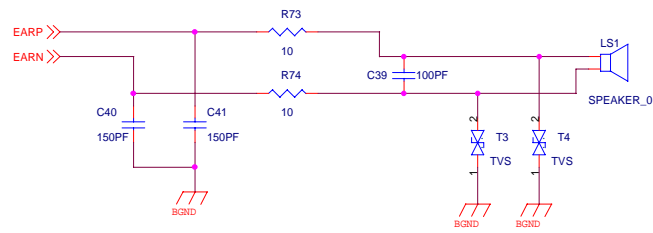

BENQ CONFIDENTIAL

Benq Corporation				
Project Code	Model Name	OEM/ODM Model Name		
99.G3121.001	SAMBA	56D76 (Samba)		
Title				
AUDIO, BUZZER & VIBRATOR				
Size	PCB P/N	PCB Rev.	Document Number	Rev.
A4	48.G3101.S01	0.1	D76 - Samba V1	0.1
Date: Thursday, May 23, 2002		Sheet 4 of 6		
Prepared By		Reviewed By		Approved By
JAMESTW WANG		WENSHIH LIU		BILL HUANG

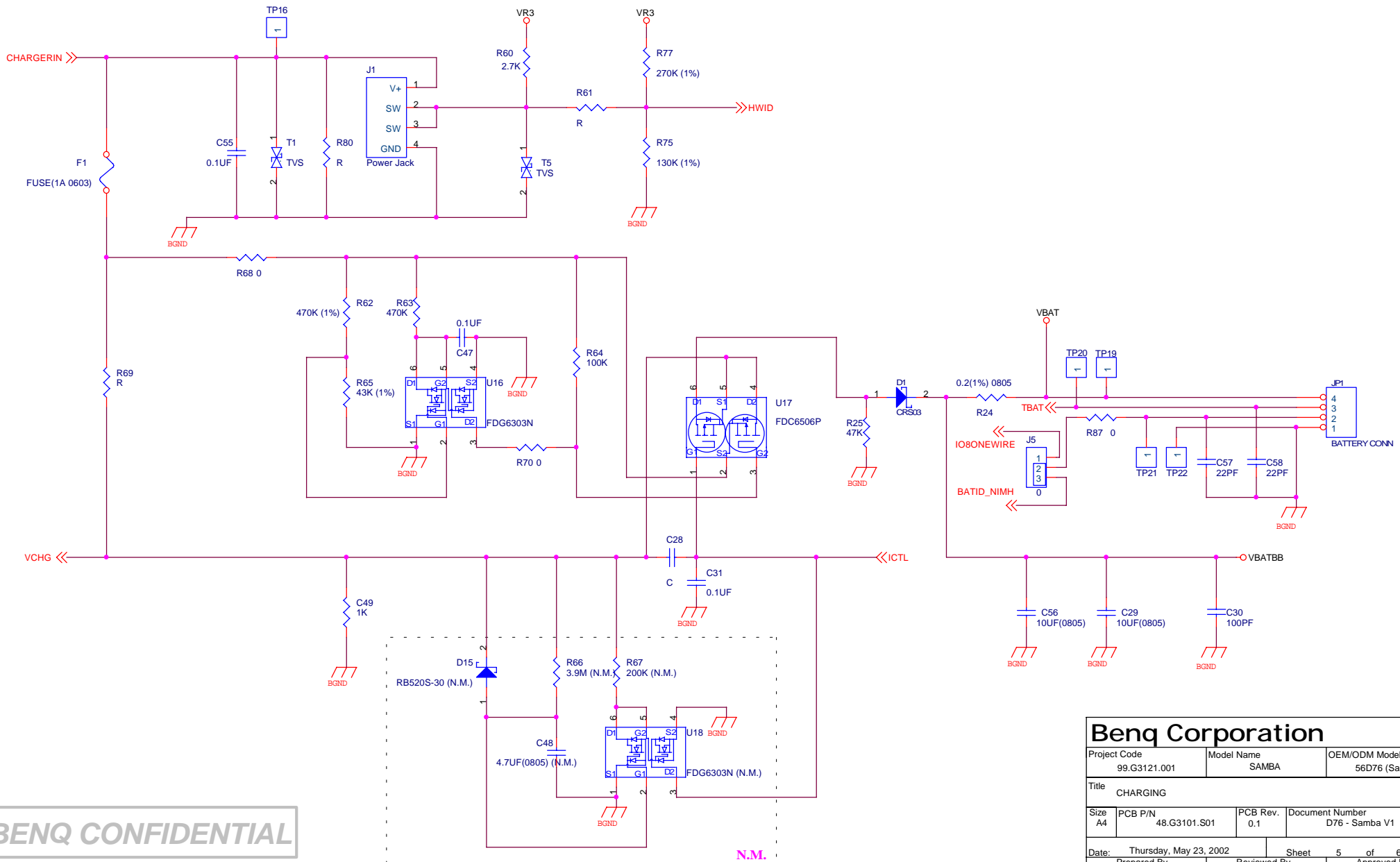

BENQ CONFIDENTIAL

Benq Corporation		
Project Code 99.G3121.001	Model Name SAMBA	OEM/ODM Model Name 56D76 (Samba)
Title CHARGING		
Size A4	PCB P/N 48.G3101.S01	PCB Rev. 0.1
	Document Number D76 - Samba V1	Rev. 0.1
Date: Thursday, May 23, 2002		Sheet 5 of 6
Prepared By JAMESTW WANG	Reviewed By WENSHIH LIU	Approved By BILL HUANG

N.M.

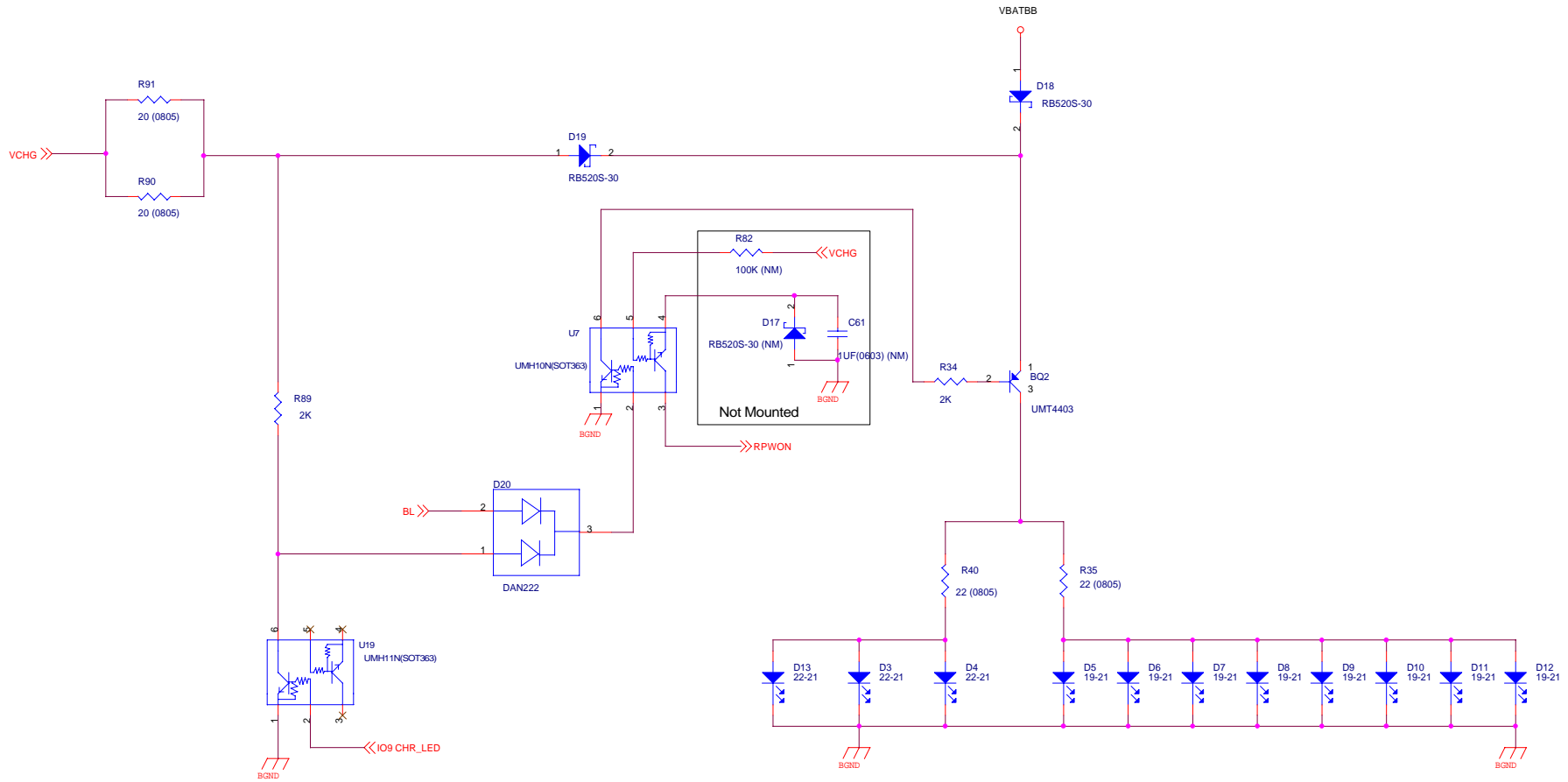

BENQ CONFIDENTIAL

Benq Corporation				
Project Code	Model Name	OEM/ODM Model Name		
99.G3121.001	SAMBA	56D76 (Samba)		
Title				
LED				
Size	PCB P/N	PCB Rev.	Document Number	Rev.
A4	48.G3101.S01	0.1	D76 - Samba V1	0.1
Date:	Thursday, May 23, 2002		Sheet	6 of 6
Prepared By	Reviewed By		Approved By	
JAMESTW WANG	WENSHIH LIU		BILL HUANG	