

MODE	INPUT CONTROL BITS			
	VLOGIC	TX_RX	BS1	BS2
STANDBY	0	0	0	0
GSM_RX1	1	0	0	0
GSM_RX2	1	0	0	1
DCS_RX3	1	0	1	0
DCS_RX4	1	0	1	1
GSM_TX	1	1	0	X
DCS_TX	1	1	1	X

X means "DON'T CARE"

L7 i-Mode\_8403655D04



# DIGITAL BASEBAND

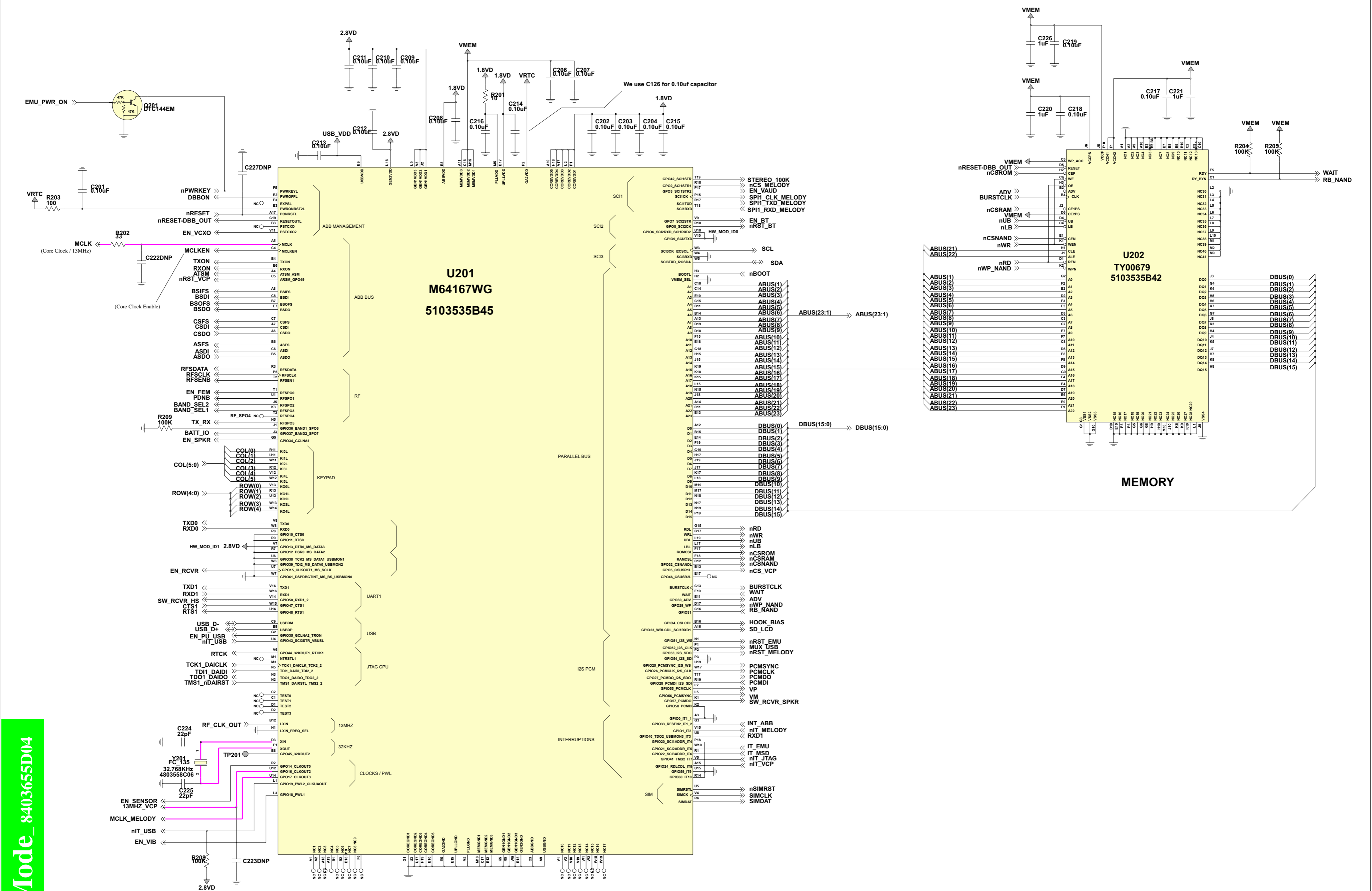

L7 i-Mode\_8403655D04



# EMU & CONNECTORS

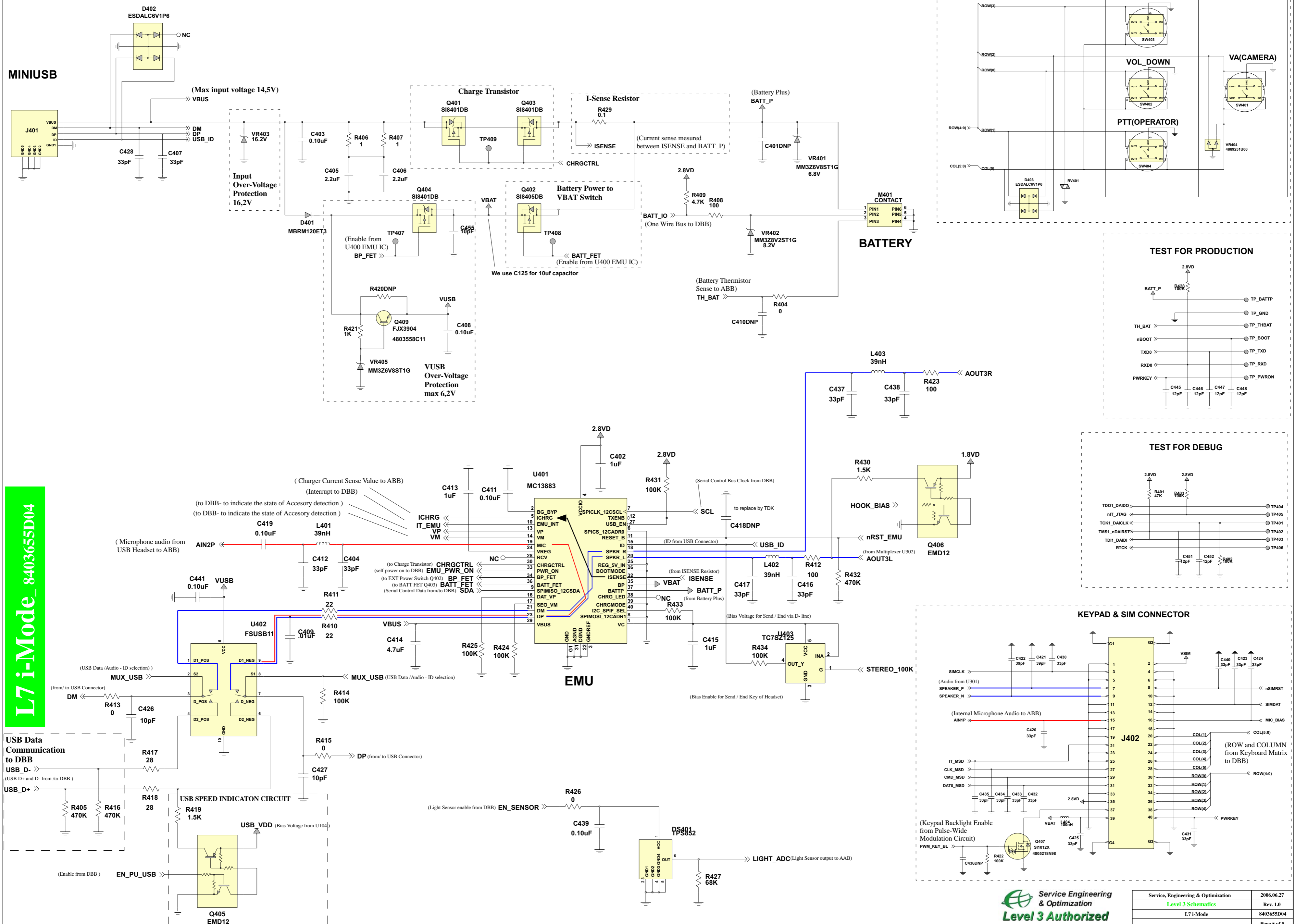

L7 i-Mode\_ 840365SD04





# BLUETOOTH

## BLUETOOTH ANTENNA

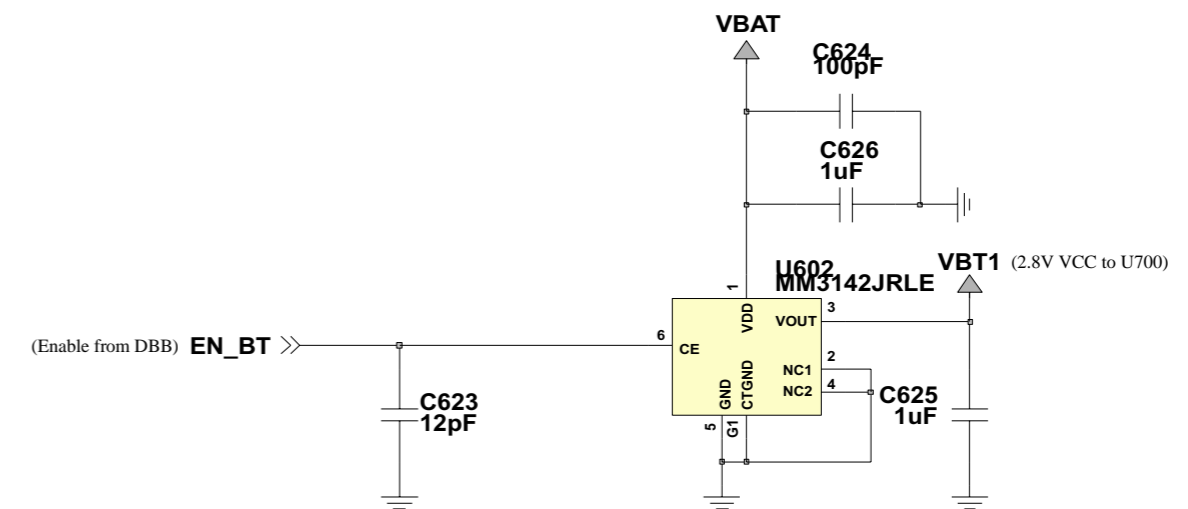
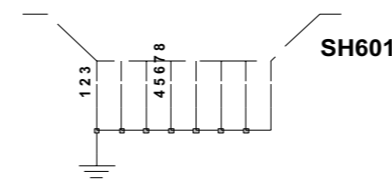
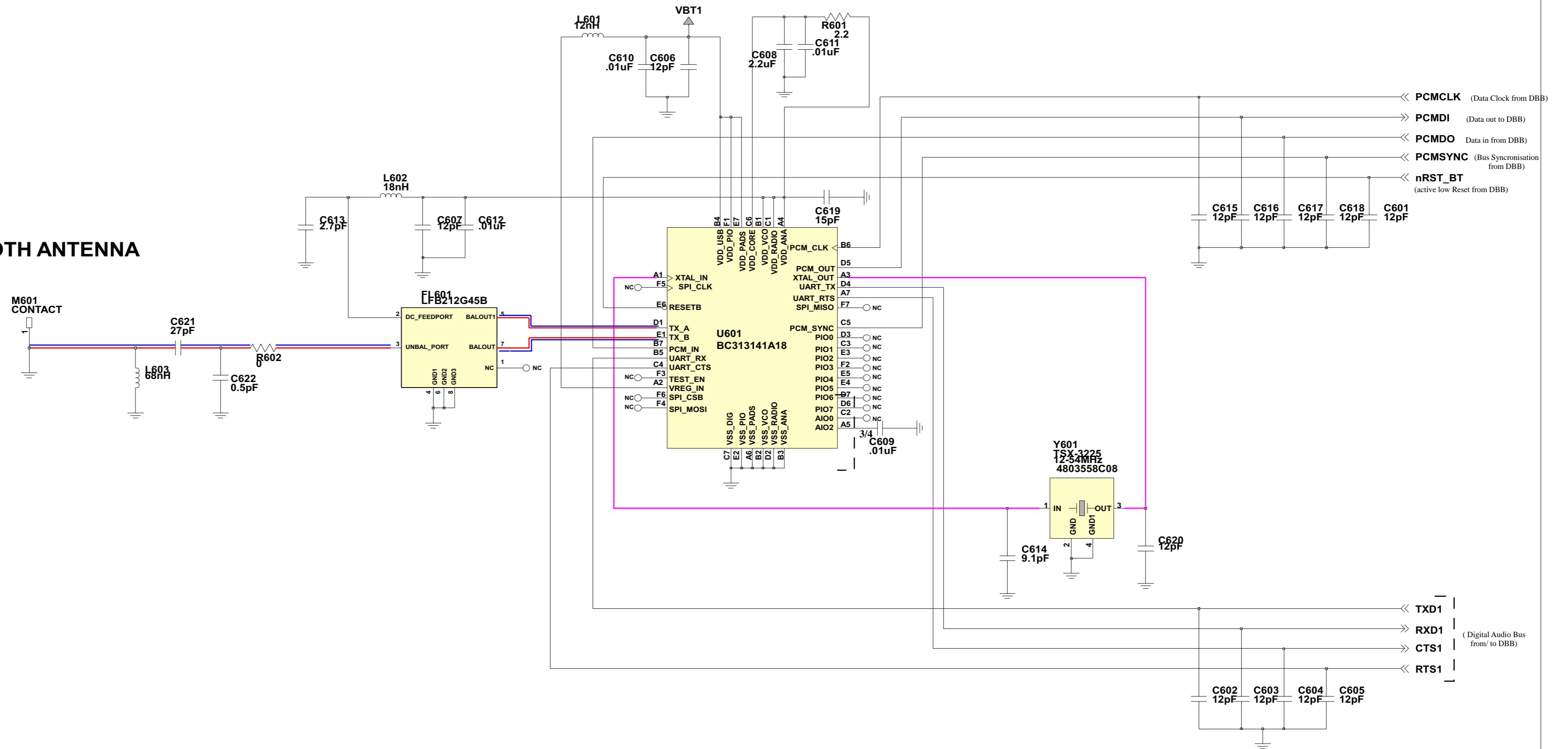

L7 i-Mode\_8403655D04

# Keyboard PCB

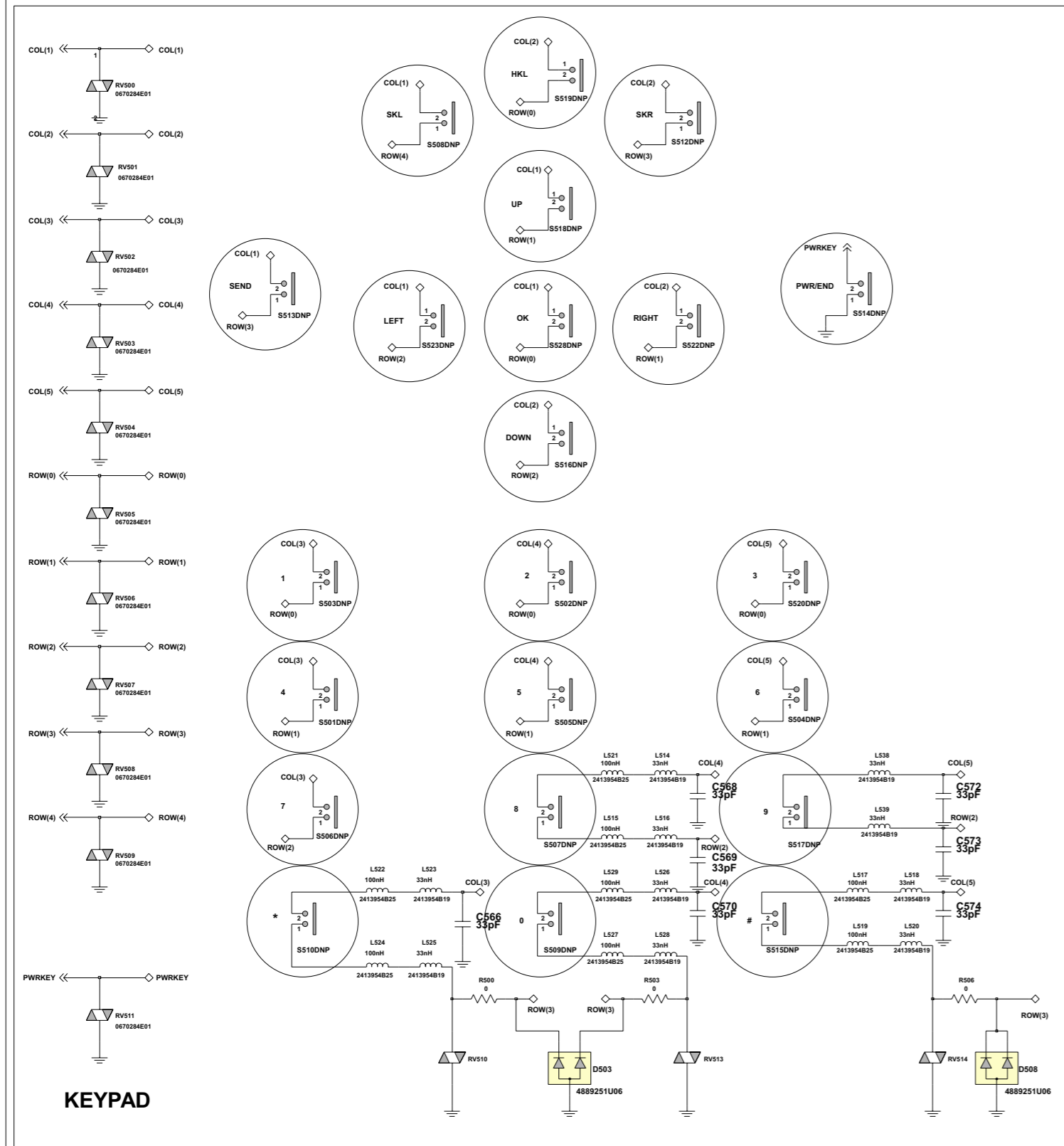

## TRI-FLASH

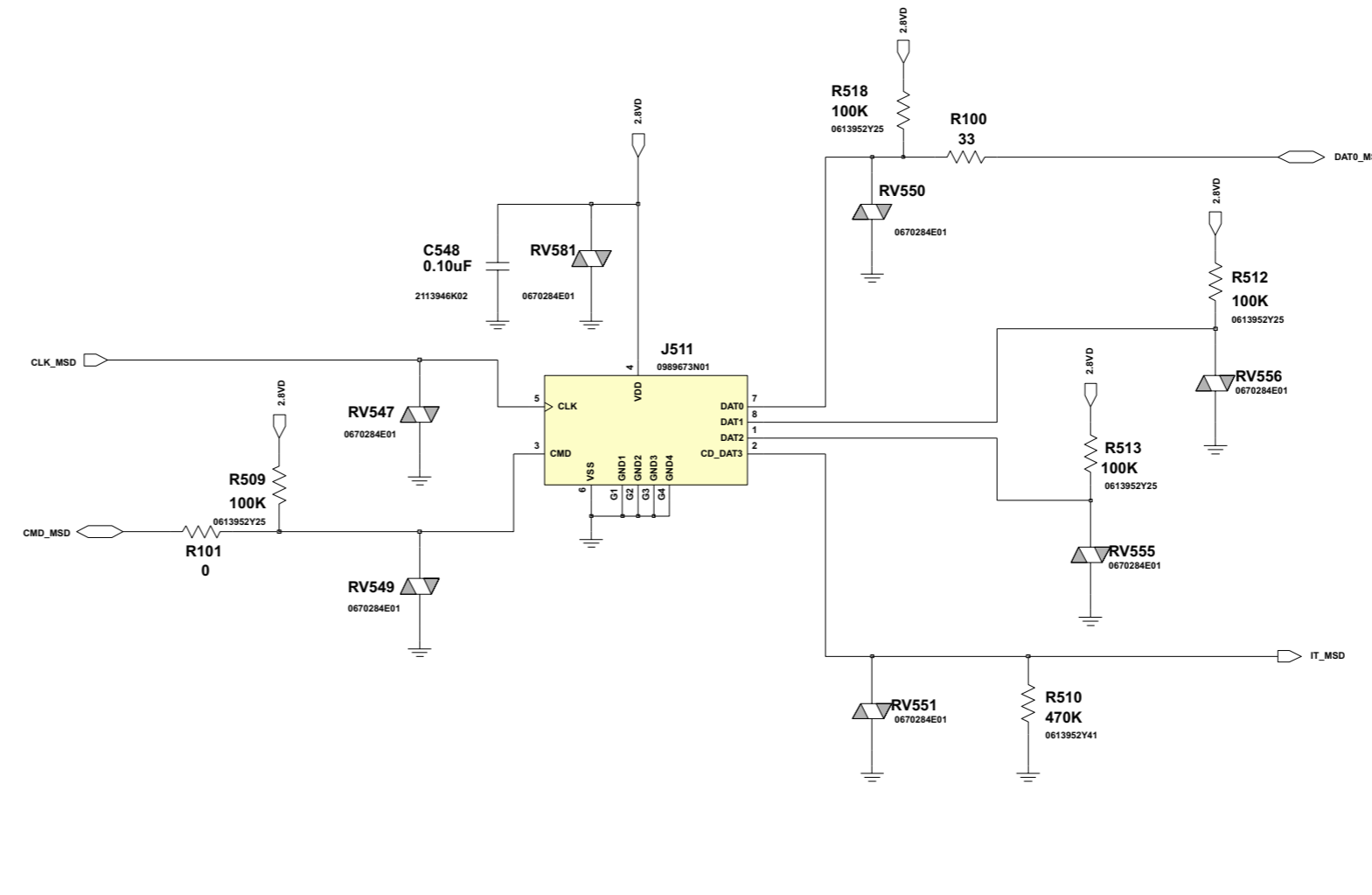

## ANTENNA

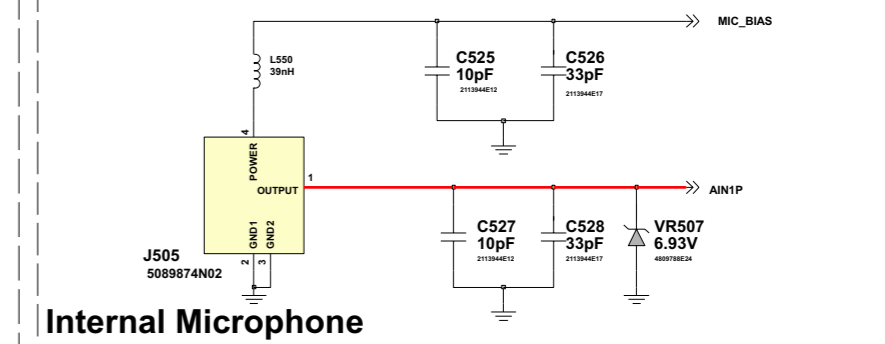
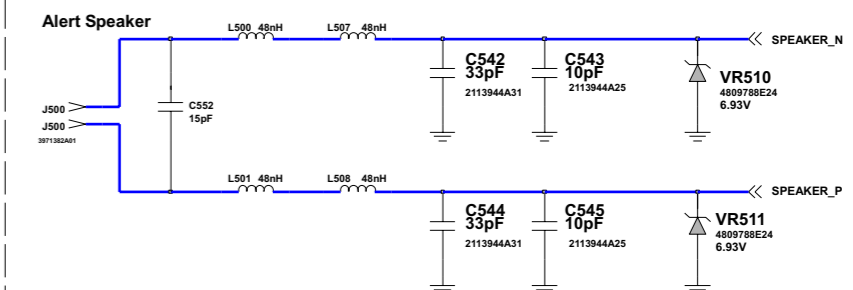
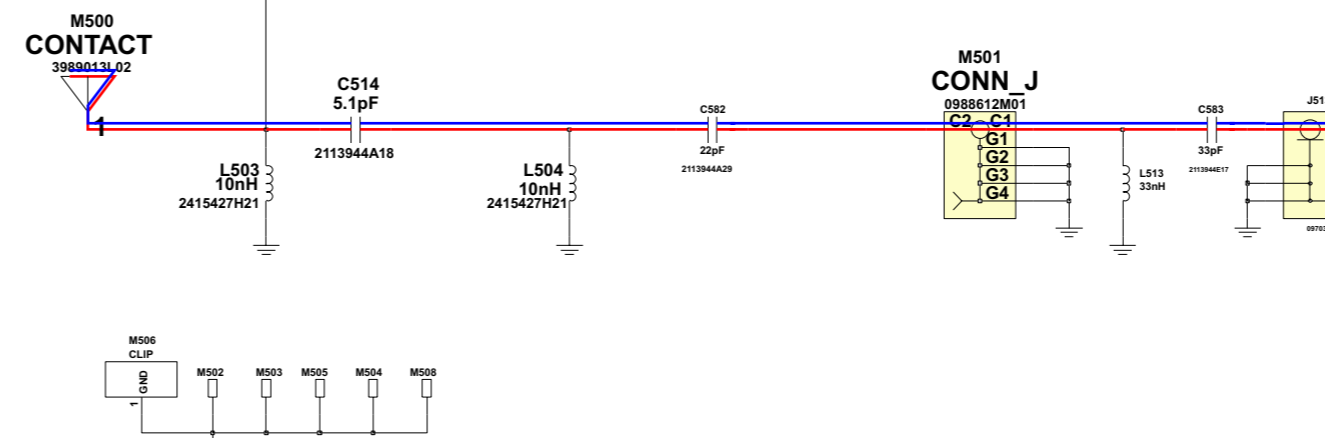

## BLUE LED Keypad

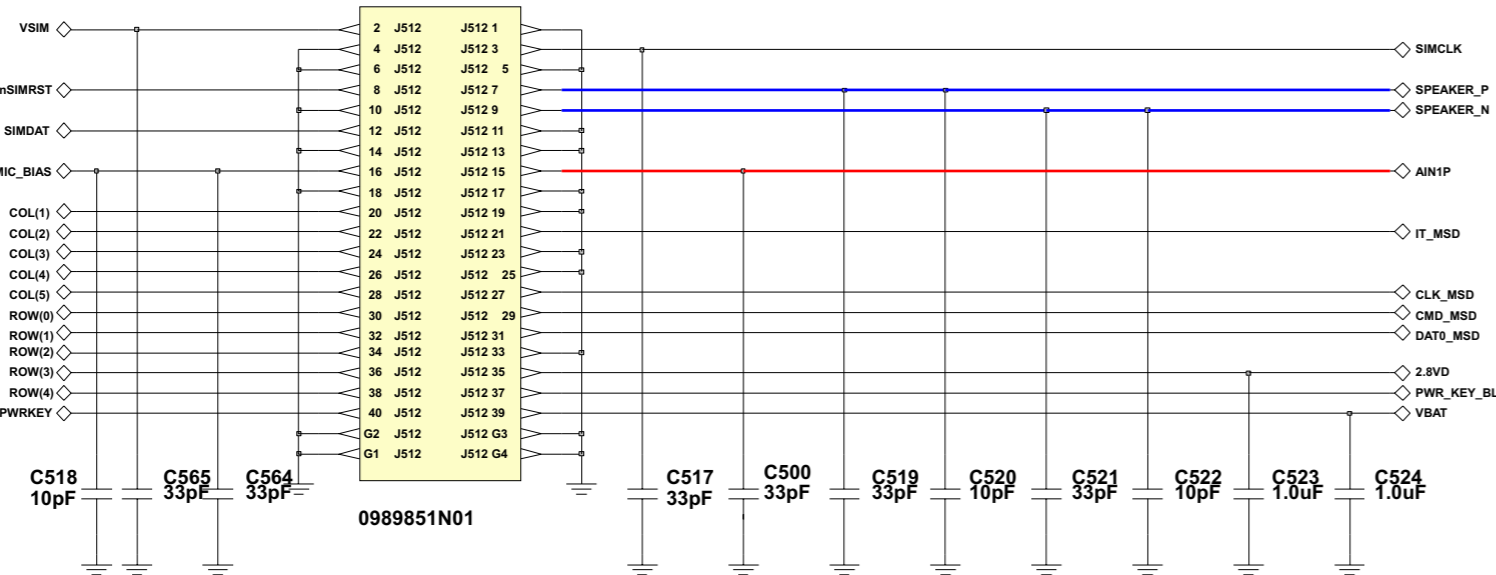
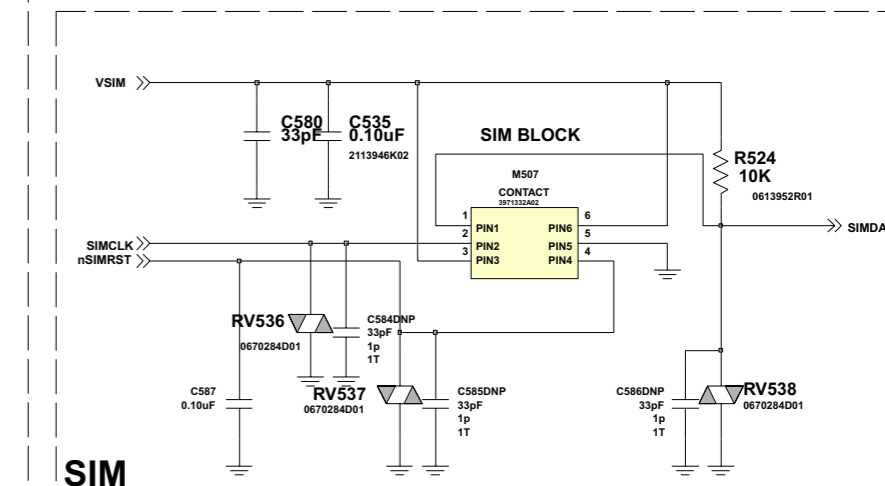
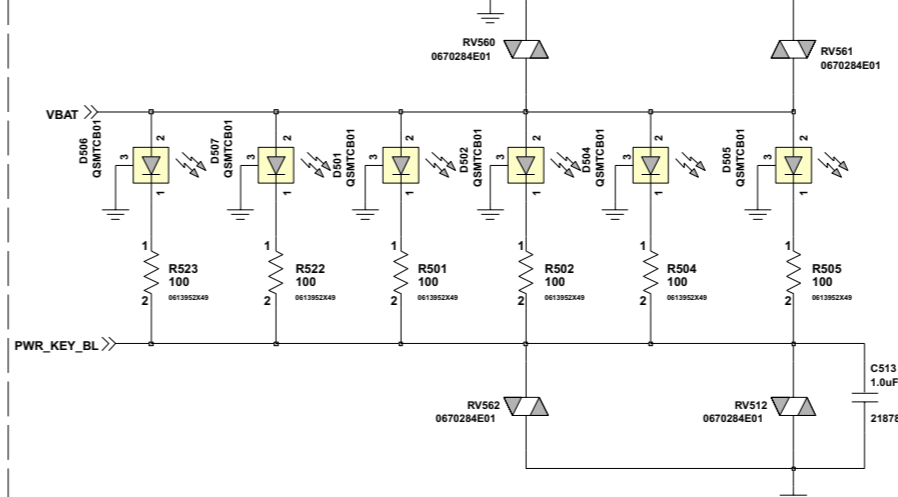

L7 i-Mode\_8403601D03