

Service Engineering & Optimization
Level 3 Authorized

Level 3 Schematics	Rev. 1.0
E1	8489233N14G
Alexander Buehler, Michael Haasem	Page 1 of 7

E1 8489233N14G

Transmitter

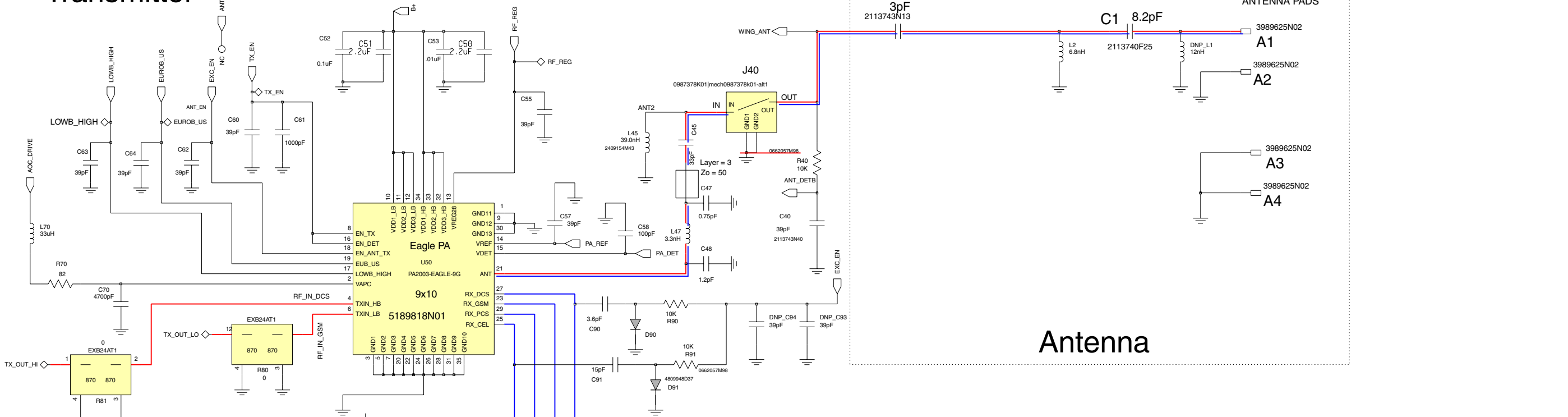

Antenna

Receiver

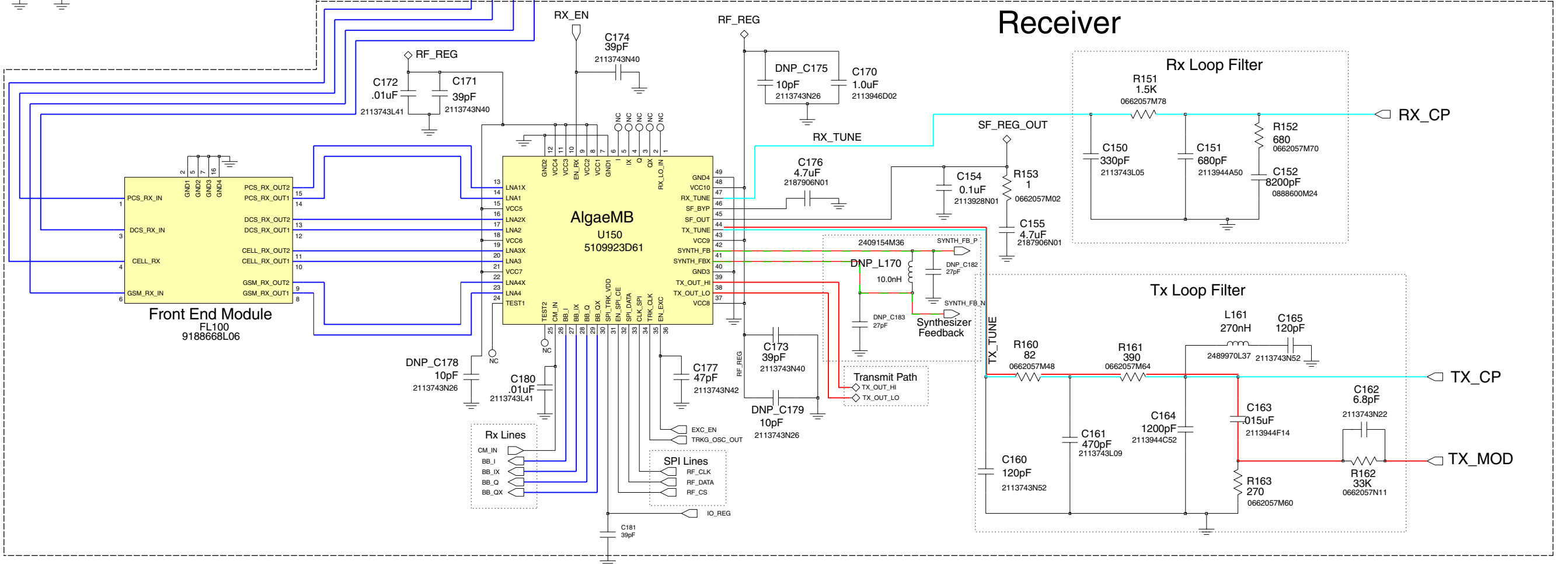

MOTOROLA CONFIDENTIAL PROPRIETARY

E1 8489233N14G

Level 3 Schematics	2005.07.22
21	Rev. 1.0
Alexander Buehler, Michael Hansen	4899333N14G
	Page 2 of 7

Service Engineering & Optimization
Level 3 Authorized

Processor and Memory

MOTOROLA CONFIDENTIAL PROPRIETARY
MOTOROLA CONFIDENTIAL PROPRIETARY

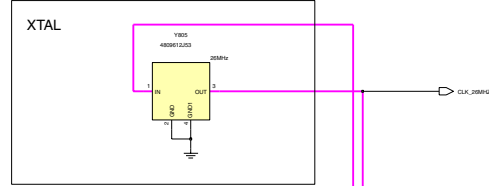
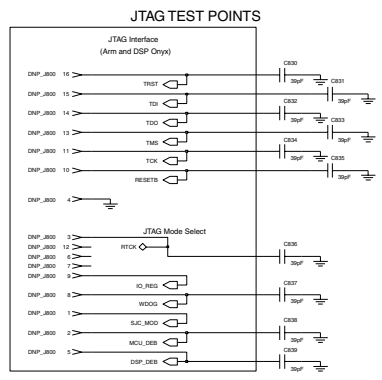

Remove the MCD Test point
and resistor R805 on the
final production board.

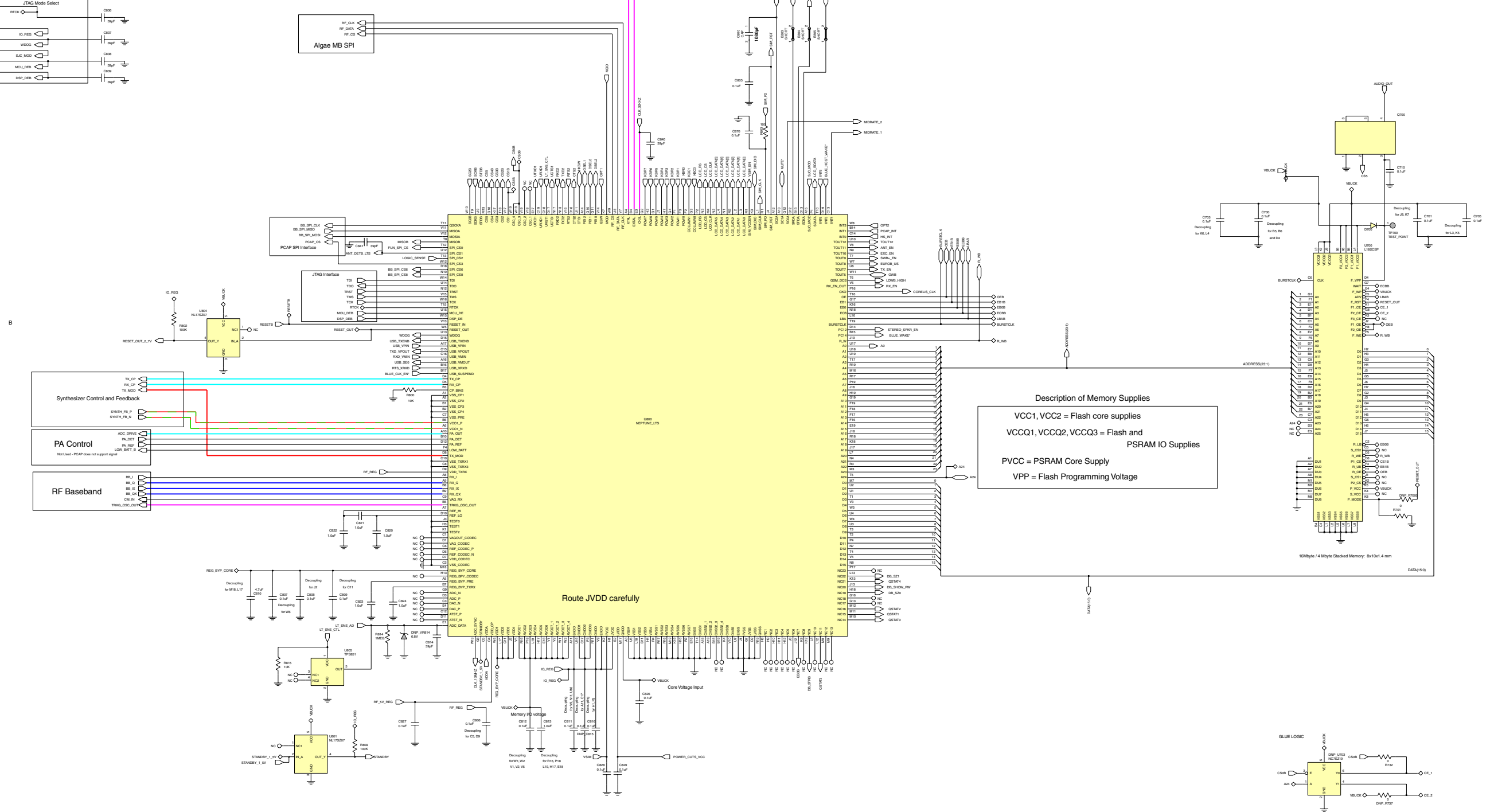

E1 8489233N14G

Level 3 Schematics	2005.07.22
E1	Rev. 1.0
Alexander Buehler, Michael Hamann	8489233N14G
	Page 3 of 7

Service Engineering & Optimization
Level 3 Authorized

Regulator, Audio, Charger, A/D Converter and RTC

MOTOROLA CONFIDENTIAL PROPRIETARY

E1 8489233N14G

Level 3 Schematics	2005.07.12
Rev. 1.0	8489233N14G
Author	Alexander Buehler, Michael Hamann
Page 4 of 7	

Service Engineering & Optimization
Level 3 Authorized

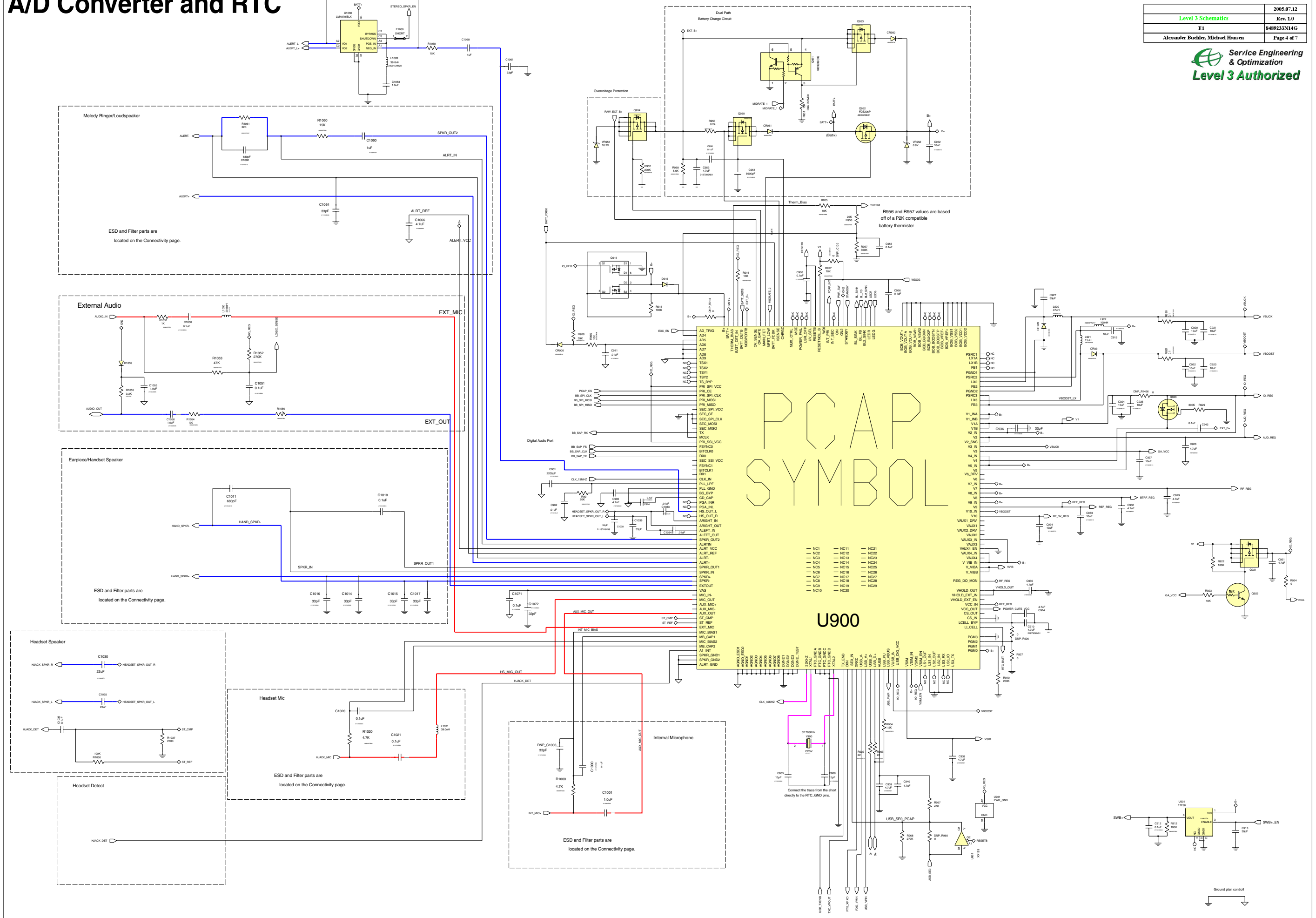

MOTOROLA INTERNAL USE ONLY

Accessory Connector CE Connector (0987636K06)

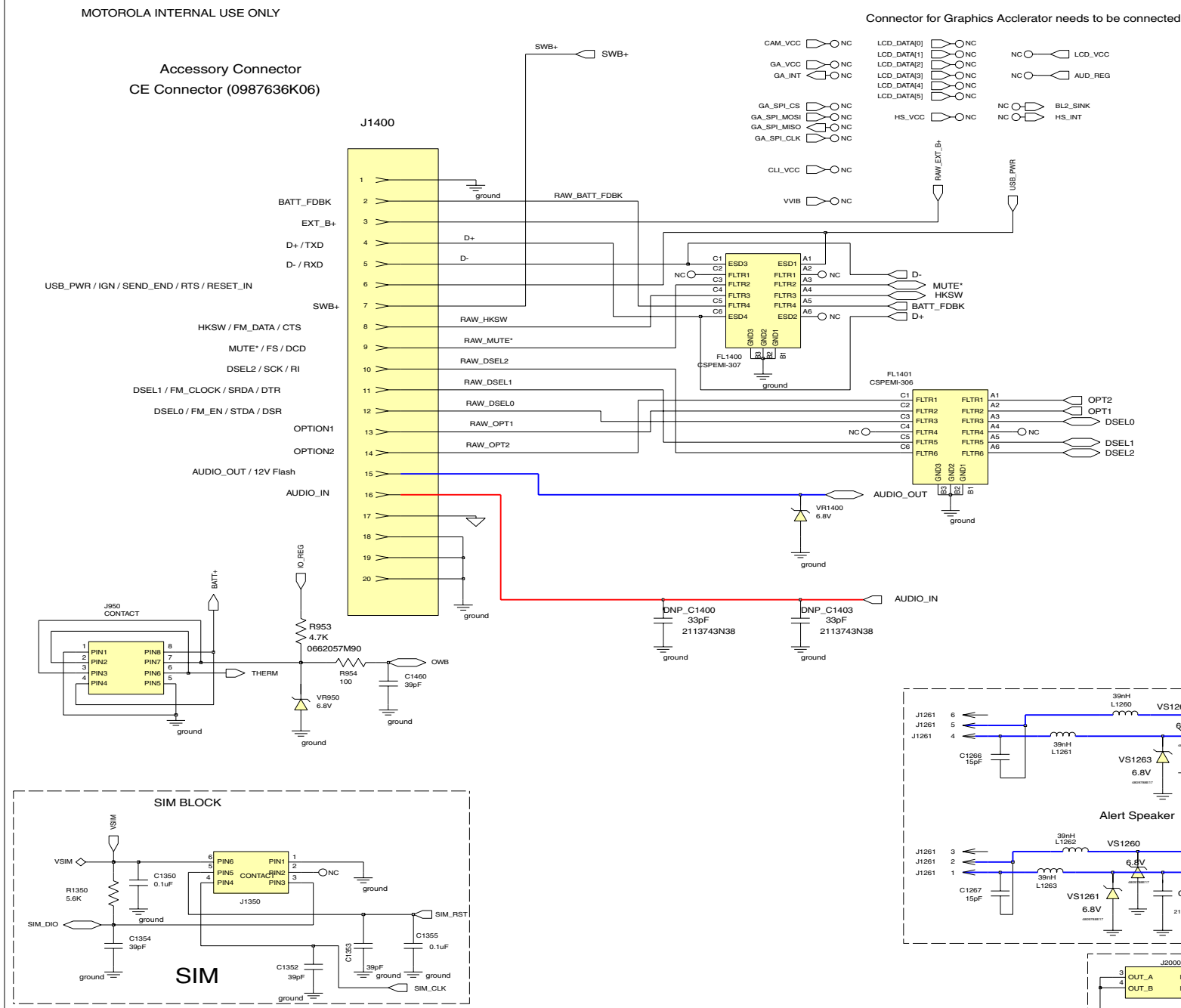

Connector for Graphics Accelerator needs to be connected

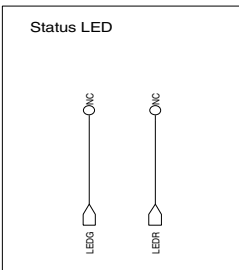

Camera Connector

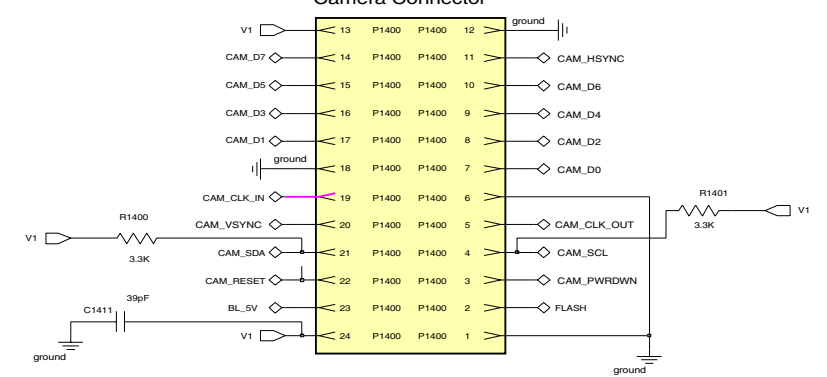

Display Connector

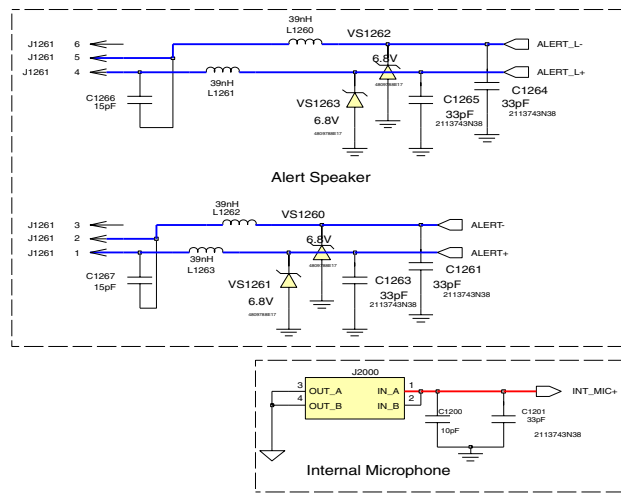
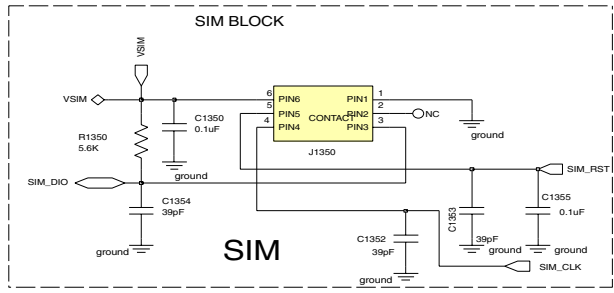
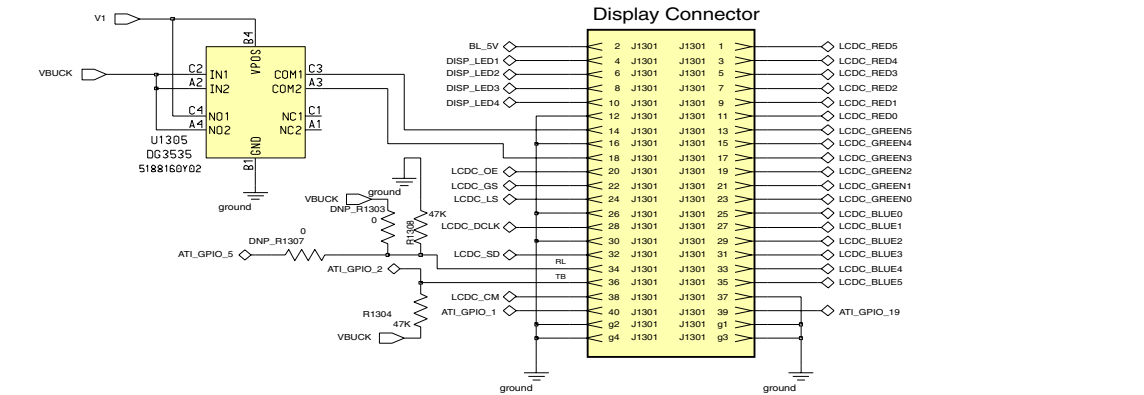

RTC Battery Connector

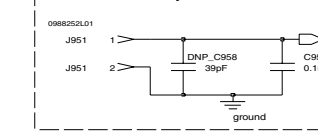

Headset Jack

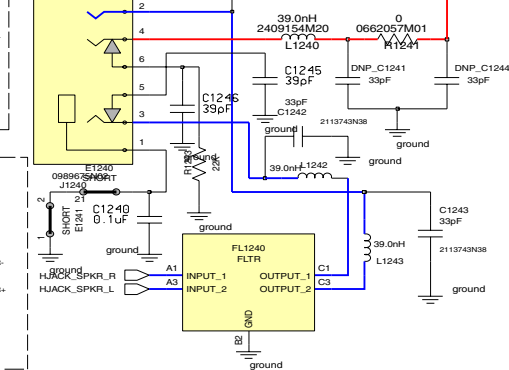

Handset Speaker

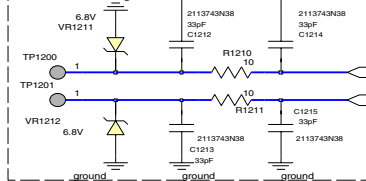

Level 3 Schematics	2865.87.12
BT	Rev. 1.0
Alexander Durbak, Michael Hamon	8489233N14G
	Page 5 of 17

E1 8489233N14G

Accessory (CE) Connector and Tri-Color Driver

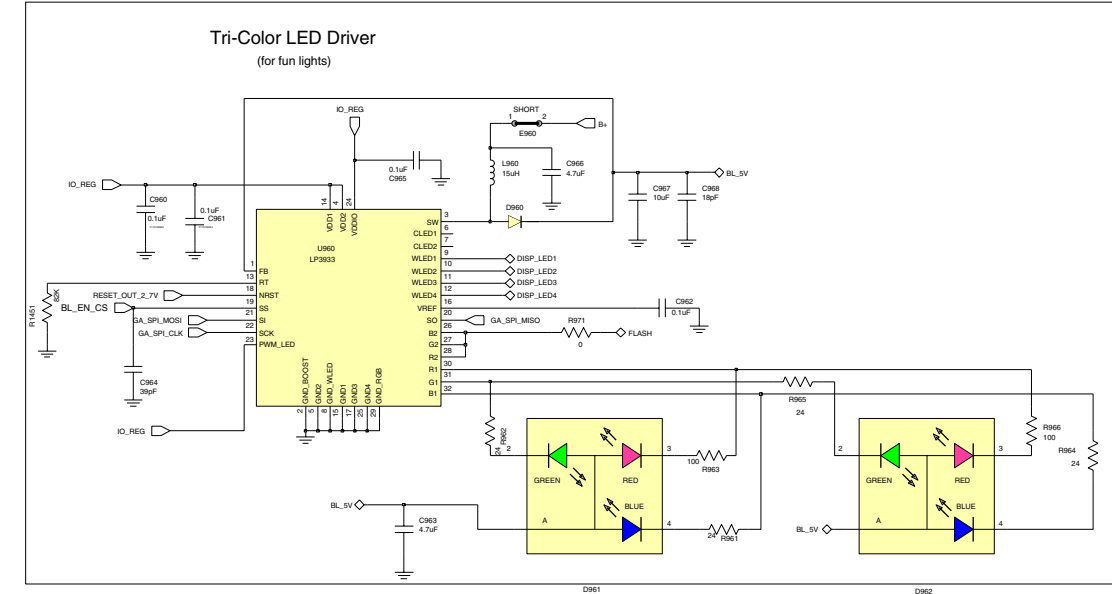

Level 3 Schematics	2005.07.12
E1	Rev. 1.0
Alexander Buhler, Michael Hamon	8489233N14G
	Page 6 of 7

Service Engineering & Optimization
Level 3 Authorized

Connector and Video/ LCD Processor with Tri-Flash Memory Cardreader

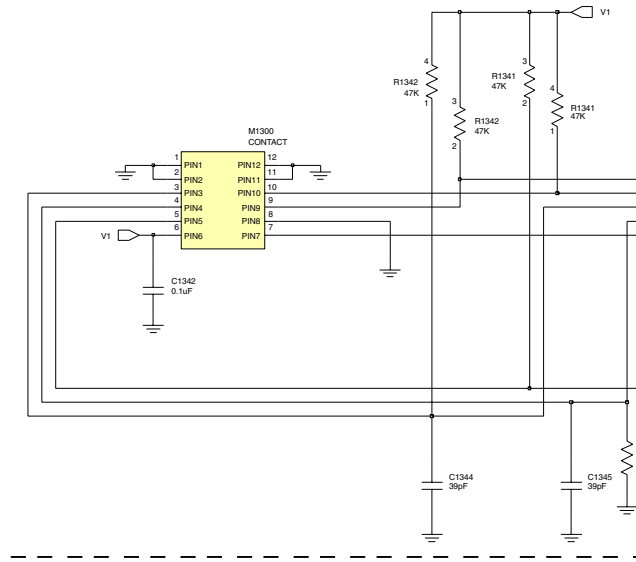
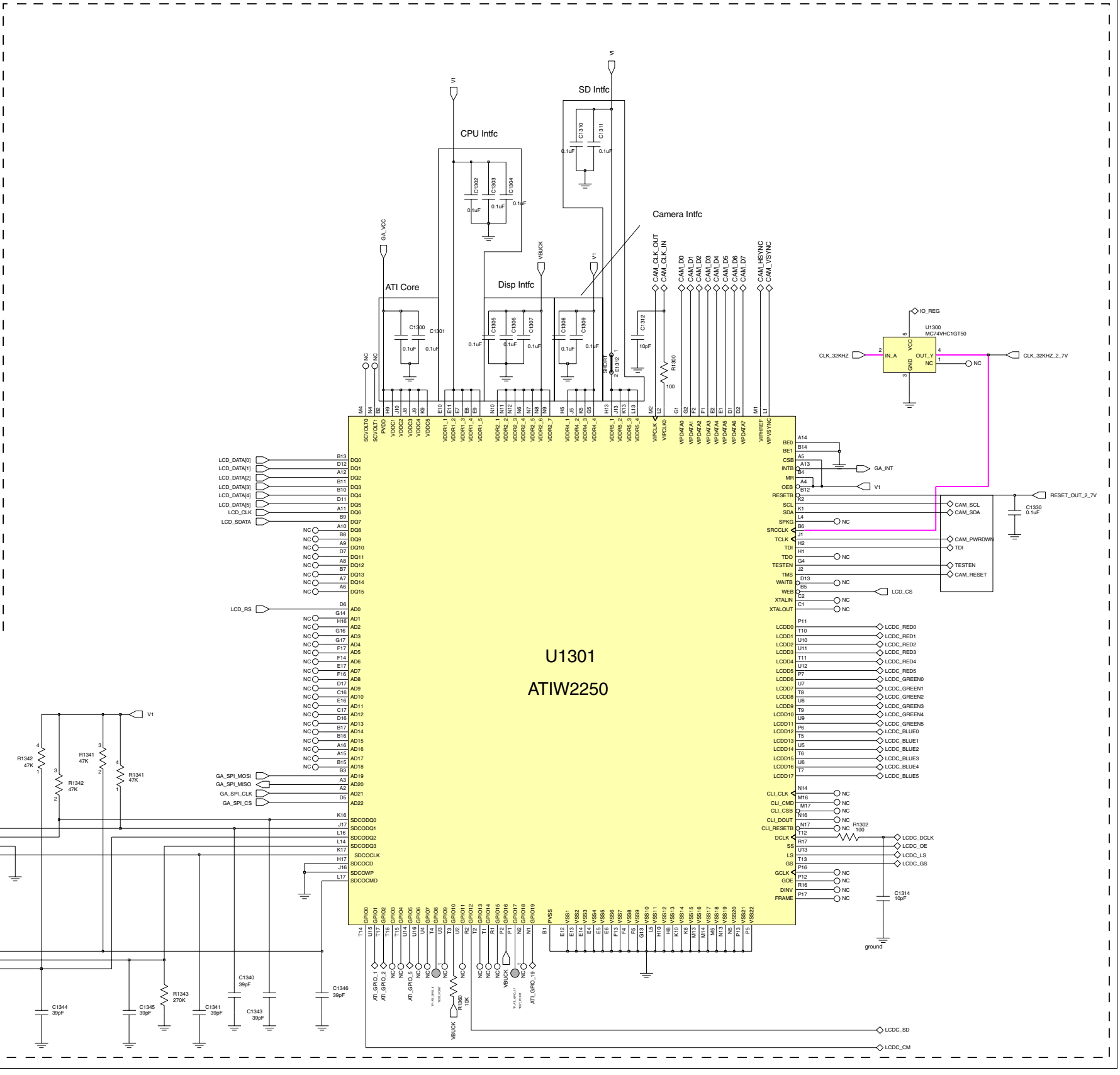
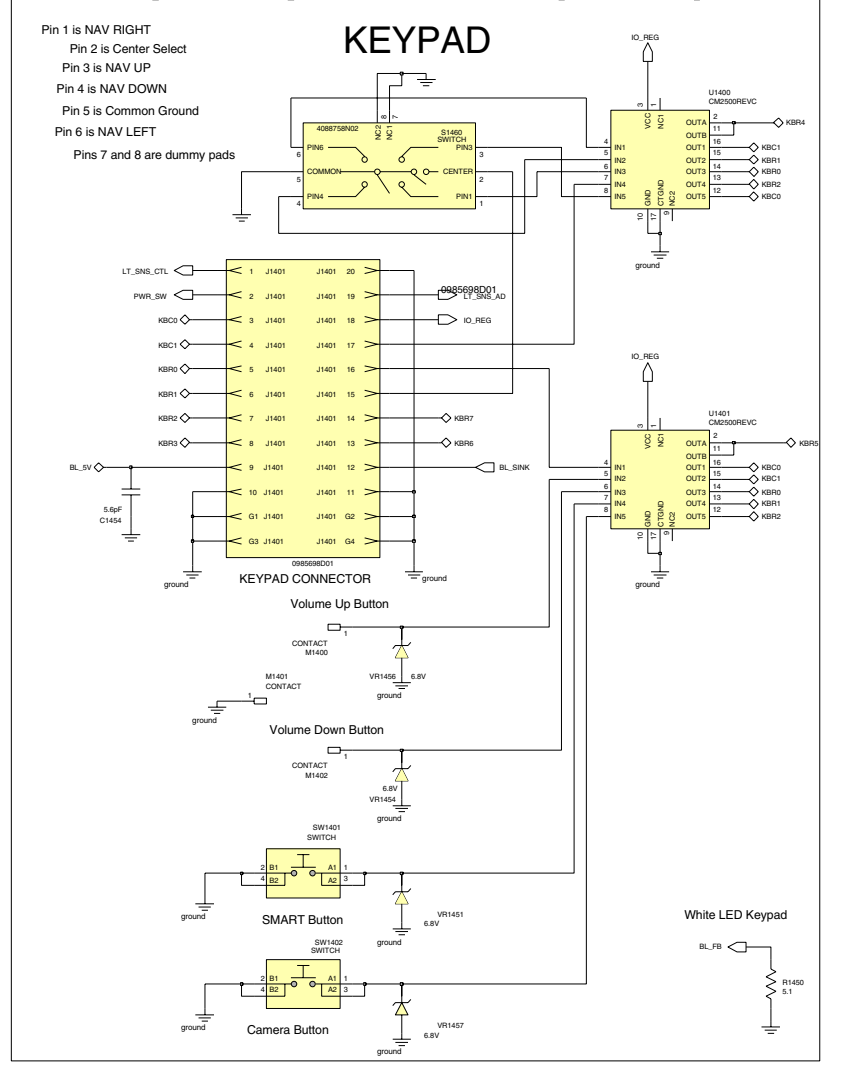

E1 Bluetooth Module Implementation

Dedicated 26 MHz Crystal Implementation

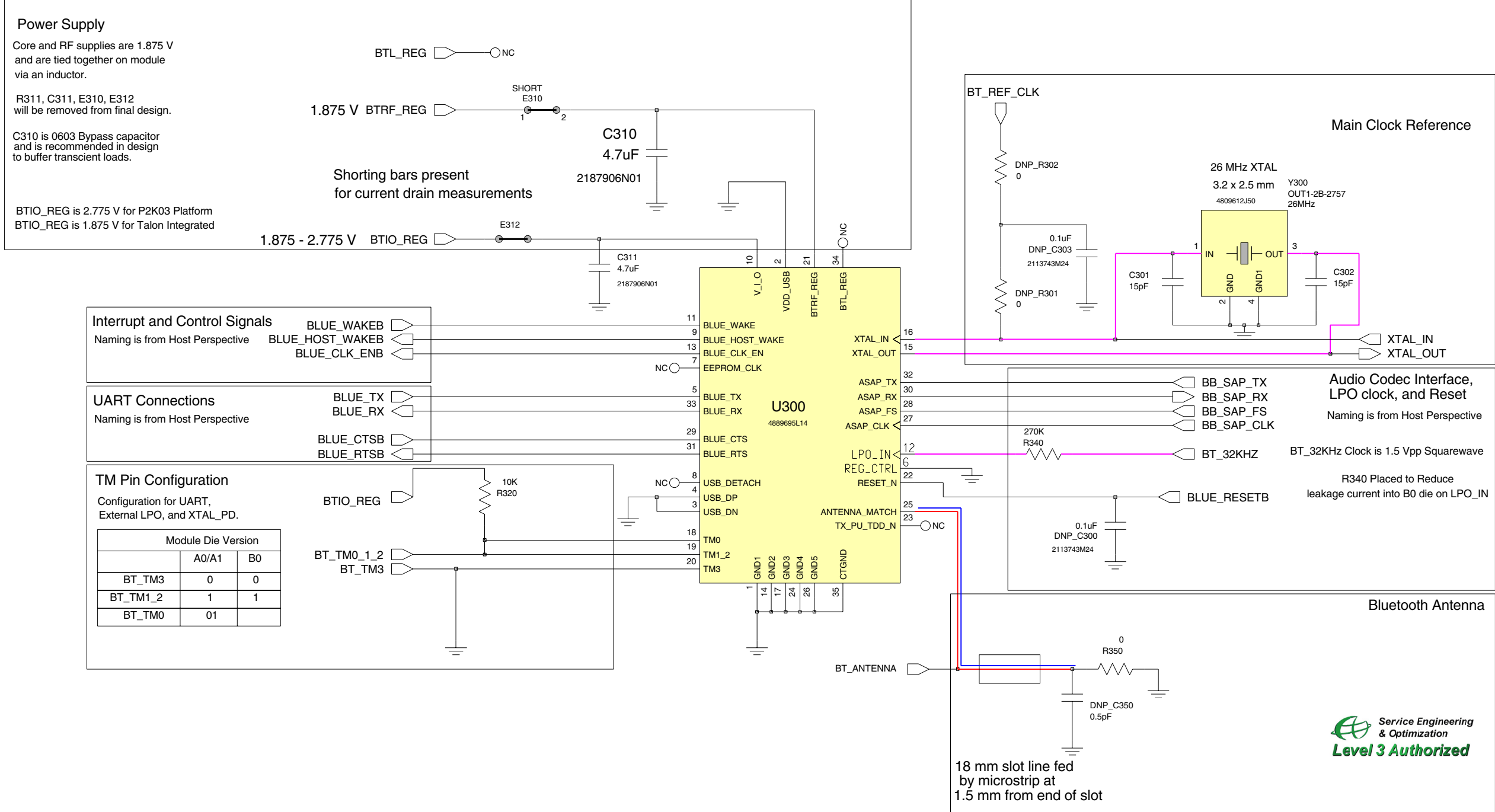

E1 8489233N14G

Service Engineering & Optimization
Level 3 Authorized

Level 3 Schematics	2005.07.12
Rev. 1.0	
81	8489233N14G
Alexander Boshin, Michael Hanson	Page 7 of 7