



MOTOROLA

Level 1 and 2 Service Manual

6809513A80-B

MOTOROKR™ Z6m

MOTORIZR™ Z6tv



CDMA 850/1900 MHz

MOTOROLA and the Stylized M Logo are registered in the US Patent & Trademark Office.
All other product or service names are the property of their respective owners.

The Bluetooth trademarks are owned by their proprietor and used by Motorola, Inc. under license.

© Motorola, Inc. 2007, 2008.
All rights reserved.

Mobile Devices Business,
8000 West Sunrise Blvd.
Mail Drop 42-16A
Plantation, Florida 33322
USA

Contents

Introduction	4
Product Identification	4
Product Names	4
Product Changes	4
Regulatory Agency Compliance	4
Computer Program Copyrights	5
About this Service Manual	5
Warranty Service Policy	6
Parts Replacement	6
Specifications	8
Product Overview	9
Features	9
General Operation	11
Color Display	12
Alert Settings	14
Battery Function	14
Tools and Test Equipment	15
Disassembly	16
Removing and Replacing the Battery Cover and Battery	16
Removing and Replacing the Memory Card	18
Removing and Replacing the Rear Housing	19
Removing and Replacing the Transceiver Board Assembly	24
Removing and Replacing the Keypad	28
Removing the Rear Housing Components	30
Removing and Replacing the Slider Assembly	38
Removing and Replacing the Main Lens	61
Removing and Replacing the Keypad Mylar	63
Slider Test Procedures	67
Phone Identification	72
Personality Transfer	72
Identification	72
Troubleshooting	74
Troubleshooting Chart	74
Programming: Software Upgrade and Flexing	75
Part Numbers	75
Exploded View Diagram	76
Parts List	77
INDEX	1

Introduction

Motorola® Inc. maintains a worldwide organization that is dedicated to provide responsive, full-service customer support. Motorola products are serviced by an international network of company-operated product-care centers as well as authorized independent service firms.

Available on a contract basis, Motorola Inc. offers comprehensive maintenance and installation programs that allow customers to meet requirements for reliable, continuous communications.

To learn more about the wide range of Motorola service programs, contact your local Motorola products representative or the nearest Customer Service Manager.

Product Identification

Motorola products are identified by the model number on a label usually located under the battery. Use the entire model number when inquiring about the product. Numbers are also assigned to chassis and kits. Use these numbers when requesting information or ordering replacement parts.

Product Names

Product names are listed on the front cover. Product names are subject to change without notice. Some product names, as well as some frequency bands, are available only in certain markets.

Product Changes

When electrical, mechanical or production changes are incorporated into Motorola products, a revision letter is assigned to the chassis or kit affected, for example; -A, -B, or -C, and so on.

The chassis or kit number, complete with revision number, is imprinted during production. The revision letter is an integral part of the chassis or kit number and is also listed on schematic diagrams and printed-circuit board layouts.

Regulatory Agency Compliance

This device complies with Part 15 of the FCC Rules. Operation is subject to the following conditions:

- This device may not cause any harmful interference
- This device must accept interference received, including interference that may cause undesired operation

This class B device also complies with all requirements of the Canadian Interference-Causing Equipment Regulations (ICES-003).

Cet appareil numérique de la classe B respecte toutes les exigences du Règlement sur le matériel brouilleur du Canada.

Computer Program Copyrights

The Motorola products described in this manual may include Motorola computer programs stored in semiconductor memories or other media that are copyrighted with all rights reserved worldwide to Motorola. Laws in the United States and other countries preserve for Motorola, Inc. certain exclusive rights to the copyrighted computer programs, including the exclusive right to copy, reproduce, modify, decompile, disassemble, and reverse-engineer the Motorola computer programs in any manner or form without Motorola's prior written consent. Furthermore, the purchase of Motorola products shall not be deemed to grant either directly or by implication, estoppel, or otherwise, any license or rights under the copyrights, patents, or patent applications of Motorola, except for a nonexclusive license to use the Motorola product and the Motorola computer programs with the Motorola product.

About this Service Manual

Using this service manual and the suggestions contained in it assures proper installation, operation, and maintenance. Refer questions about this manual to the nearest Customer Service Manager.

Table 1. Manual Revision History

Revision	Issue Date	Description
A	January 28, 2008	Initial Release

Audience

This service manual aids service personnel in testing and repairing Z6m/Z6tv telephones. Service personnel should be familiar with electronic assembly, testing, and troubleshooting methods, and with the operation and use of associated test equipment.

Use of this manual assures proper installation, operation, and maintenance of Motorola products and equipment. It contains all service information required for the equipment described and is current as of the printing date.

Scope

This manual provides basic information relating to Z6m/Z6tv telephones, and provides procedures and processes for repairing the units at Level 1 and 2 service centers including:

- Unit swap out
- Repairing of mechanical faults
- Basic modular troubleshooting
- Testing and verification of unit functionality
- Initiate warranty claims and send faulty modules to Level 3 or 4 repair centers

Conventions

The following special characters and typefaces are used in this manual to emphasize certain types of information.



Note: Emphasizes additional information pertinent to the subject matter.



Caution: Emphasizes information about actions that may result in equipment damage.



Warning: Emphasizes information about actions that may result in personal injury.



Keys to be pressed are represented graphically. For example, instead of “Press the End key”, you will see “Press ”.

Warranty Service Policy

The product is sold with the standard 12-month warranty terms and conditions. Accidental damage, misuse, and extended warranties offered by retailers are not supported under warranty. Non warranty repairs are available at agreed fixed repair prices.

Out-of-Box Failure Policy

The standard out of box failure criteria applies. Customer units that fail very early on after the date of sale, are to be returned to Manufacturing for root cause analysis, to guard against epidemic criteria. Manufacturing will bear the costs of early life failure.

Product Support

Customer's original units will be repaired but not refurbished as standard. Appointed Motorola Service Hubs will perform warranty and non-warranty field service for level 2 (assemblies) and level 3 (limited PCB component). The Motorola High Technology Centers will perform level 4 (full component) repairs.

Customer Support

Customer support is available through dedicated Call Centers and in-country help desks. Product Service training is available through the local Motorola Support Center.

Parts Replacement

When ordering replacement parts or equipment, include the Motorola part number and description used in the service manual.

When the Motorola part number of a component is not known, use the product model number or other related major assembly along with a description of the related

major assembly and of the component in question.

Replacement Parts Service Division (RPSD)

Order replacement parts, test equipment, and manuals from RPSD.

U.S.A.

Phone: 800-422-4210

FAX: 800-622-6210

Website: <http://businessonline.motorola.com>

Outside U.S.A.

Phone: 847-538-8023

FAX: 847-576-3023

EMEA

Phone: +49 461 803 1404

Website: <http://emeaonline.motorola.com>

Asia

Phone: +65 648 62995

Website: <http://asiaonline.motorola.com>

Specifications

General Function	Specification
Frequency Range 1900 MHz PCS	1931.250 -1988.750 MHz Rx 1851.250 -1908.750 MHz Tx
Frequency Range 800 MHz CDMA	869.64 - 893.37 Rx (CDMA) 824.64 - 848.37 Tx (CDMA)
Channel Spacing	50 kHz PCS 30 kHz CDMA
Channels	1150 PCS 788 CDMA 800
Modulation	1M25F9W (1.25 MHz bandwidth) CDMA 3G1XR TT (1.25 MHz bandwidth) CDMA-1X
Duplex Spacing	80 MHz PCS 45 MHz CDMA 800
Frequency Stability	± 150 Hz (CDMA)
Power Supply	3.7V Li Ion 940 mAh battery
Average Transmit Current	238 mA CDMA 800 (Avg) 247 mA PCS 1900 (Avg)
Average Stand-by Current (slot cycle 2)	2.07 mA (CDMA 800) 2.22 mA (PCS 1900)
Temperature Range	-10° C to +55° C (+15° F to +130° F)
Dimensions, (xyz)	45.5 mm x 105.5 mm x 16.2 mm
Size (Volume)	69 cc (4.21 in ³), with battery
Weight	108.0 grams with battery
Battery Life, with standard 940 mAh Li-Ion Battery	Talk Time 270 minutes Standby time 390 hours All talk and standby times are approximate and depend on network configuration, signal strength, and features selected. Standby times are quoted as a range from DRX=2 to DRX=9. Talk times are quoted as a range from DTX off to DTX on.
Battery Charge Time	4 hours to 90% of 940 mAh capacity
Alert volume	Max 95 dB @5cm, 0.5 Watts input

Transmitter Function	Specification
RF Power Output	0.30 watts +25 dBm into 50 ohms (CDMA/PCS nominal)
Spurious Emissions	- 18.5 dBm (max) from 0.03 to 19 GHz
Input/Output Impedance	50 ohms (nominal)
CDMA Transmit Waveform Quality (Rho)	0.94

Receiver Function	Specification
Receive Sensitivity	-104 dBm (CDMA/PCS, 0.5% Static FER) 0.5% or less
RX Bit Error Rate (100k bits) Type II	< 2%

MediaFLO (Z6tv Only)	Specification
MediaFLO format	QUALCOMM packet data technology (USA)
Modulation/Coding:	OFDM, turbo, Reed-Solomon
MediaFLO Frequency	6 MHz block of the lower 700 MHz in the US.
MediaFLO Video Watch Time	Goal ~3.8 hours (at 360kbps)

Product Overview

Motorola's MOTOROKR Z6m and Z6tv mobile telephones feature Code Division Multiple Access (CDMA) technology. The mobile telephone uses a simplified icon and Graphical user interface (GUI) for easier operation, allows Short Message Service (SMS) text messaging, and includes clock, alarm, datebook, calculator, and caller profiling personal management tools. The Z6m and Z6tv telephones include a built in camera. The phone provides 32 embedded ring tones, including VibraCall vibrating alert, and 32 Downloadable/Customizable iMelody ring tones. The Z6m and Z6tv telephones are dual-band devices that allow roaming within the CDMA 800 MHz and PCS 1900 MHz bands.

The telephones feature the slider form factor. They feature a 2.0 inch 240 x 320 262K color TFT display. The bottom part of the phone contains the keypad, transceiver printed circuit board (PCB), microphone, flex connection, external accessory connector, smart button, volume buttons, and voice button. The standard 940 mAh Lithium Ion (Li Ion) battery fits behind a removable back cover.

With the optional Mobile Phone Tools software™, inexpensive, direct connection to a computer or handheld device is available through the phone's USB port and optional data cable accessory. This connection provides the ability for data and fax calls, and synchronizing phonebook entries.

Features

Z6m and Z6tv telephones use advanced, self-contained, sealed, custom integrated circuits to perform the complex functions required for CDMA communication. Aside from the space and weight advantage, microcircuits enhance basic reliability, simplify maintenance, and provide a wide variety of operational functions.

Additionally, the Z6tv features MediaFlo, a FLO-based programming lineup that utilizes 30 frames-per second (fps) QVGA (a Quarter Video Graphics Array or 240x320 pixels) with stereo audio includes 14 real-time streaming video channels of wide-area content (such as national content) and 5 real-time streaming video channels of local market specific content. This can be delivered concurrently with 50 nationwide non-real time channels (consisting of pre-recorded content) and 15 local non-real-time channels, with each channel providing up to 20 minutes of content per day.

Features available in this family of telephones include:

- 2MP camera with 8x zoom
- Video capture/playback/streaming w/progressive download
- Large Keys, Dedicated Portal Key
- MMS, WV, EMS, SMS
- microSD™ slot for upgradeable memory
- Integrated MP3 player
- Video playback (MPEG4/H.263)
- World-class talk and standby times
- Loud, clear audio
- Large, color display (2.0 inch 240 x 320 262K)
- High quality finish
- Bluetooth® (class 2 w/A2DP support)
- Bluetooth stereo headset compatible
- MP3 ring tones
- Java

- Games (embedded & downloadable)
- PC synchronization via high speed USB
- Acoustic reliability with separate speakers for alert and earpiece

Speaker Dependent Voice Activation and Voice Note Recording

Voice tags can be used for voice dialing up to 20 phone numbers in the phone book and for creating up to 5 voice shortcuts for menu items. The phone must be “trained” by the voice tag being read into the phone’s memory twice before it is recognized.

You can add voice tags to the phone’s memory using the usual name addition methods (i.e., via the phone book menu structure or with the shortcut editor).



You cannot place or receive calls while adding voice tags to the phone’s memory.

Z6m/Z6tv telephones also include a voice recorder that allows up to 2 minutes of personal messages to be recorded. This feature has a complete set of record, playback, and management tools that make it easy to store and maintain a list of personal memos.

General Operation

The Z6m and Z6tv telephone controls are located on the sides of the device and on the keypad. Indicators, in the form of icons, are displayed on the LCD. The phones have an audible polyphonic speaker on back of the phone at the bottom (see Figure 1).

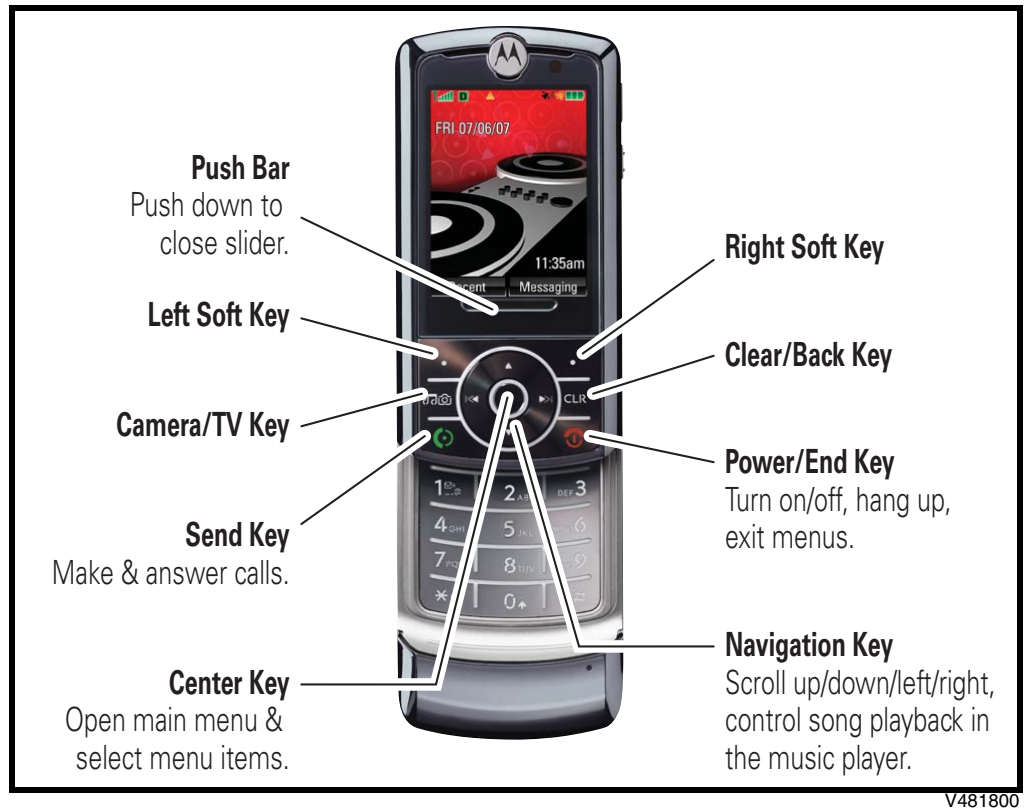

Figure 1. Controls, indicators, and I/O

“Soft keys” refer to non-labeled keys that correspond to text options displayed on the screen. The left and right soft keys perform the function shown in the corners of the display. The right key will usually select an option whereas the left key will usually exit a function or return to a previous screen.

The center key opens the initial menu structure, or allows access to a submenu.

I/O connectors, consisting of a headset jack and a mini USB accessory port, located on the left and right side of the phone respectively. The volume keys, smart key,

voice command key, controls are also located on the sides of the Z6m/Z6tv (see Figure 2).



v481801

Figure 2. Controls, indicators, and I/O (Side Views)

Color Display

The Z6m and Z6tv wireless phones feature a 262K color Thin Film Transistor (TFT) 2.0" 240 x 320 pixel display.

The home screen appears when you turn on the phone. The home screen may look different, depending on the service provider (see Figure 3).

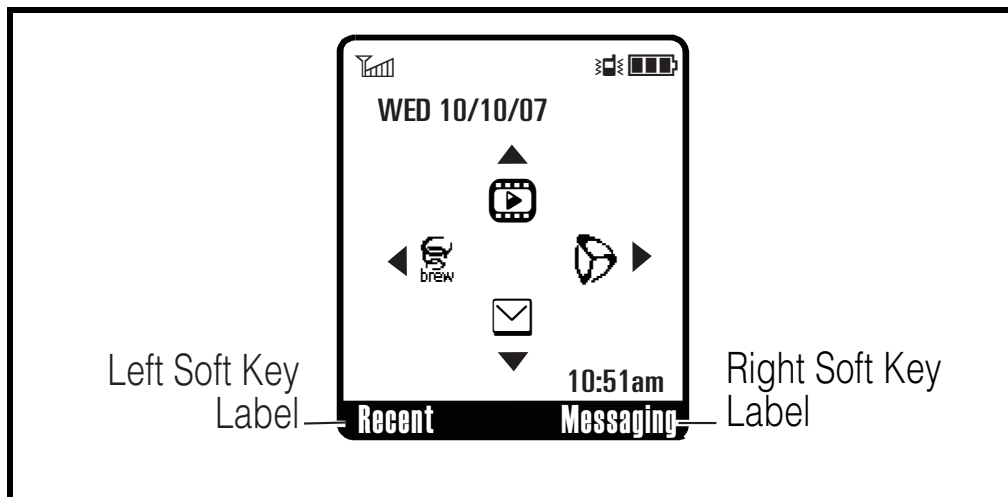

061789a







Figure 3. Home Screen Display



Whether a phone displays all indicators depends on the programming and services to which the user subscribes.

Status indicators can appear across the top of the home screen:

Indicator	
Signal Strength	EVDO indicator shows when phone is in EVDO coverage area (necessary for V CAST services). 1X indicator shows when phone is in 1x-RTT coverage area. The number of bars show the strength of each signal.
Roaming	Indicates phone is in a digital coverage area and is roaming off network.
SSL	Indicates application verification is via SSL during a download session.
Data Call, Tethered, or Embedded WAP/BREW Application	Shows during data call, tethered mode, or WAP/BREW application.
Dormant	Indicates phone is dormant and PPP session is active.
No Service	Phone is in area with no service coverage.
No V CAST TV Service	Phone is in an area with no TV service coverage.
TTY	Phone is in TTY mode.
Voice Call	Shows during an active voice call.
E911	Indicates E911 is on.
Location On	Shows when Location is set to On.
Battery Level	Shows battery charge level. The more bars, the greater the charge.
All Sounds Off	Indicates Master Volume is set to Off.
Alarm Only	Indicates Master Volume is set to Alarm Only.
Vibrate On	Indicates Master Volume is set to Vibrate On.
Speakerphone	Indicates speakerphone is on.

Indicator (Continued)	
	Indicates a call was missed.
Missed Call	
	Appears when you receive a new text message.
Message	
	Shows number of calendar appointments.
Calendar Event	
	Appears when you receive a new voicemail message.
New Voicemail	
	Shows when an alarm has been set.
Alarm On	
	Your phone is paired to another Bluetooth device.
Bluetooth Connection Active	

Alert Settings

Z6m and Z6tv telephones include up to 32 preset alert tones and vibrations that can be applied to all alert events at the same time.



Pressing either volume key will mute the alert.

Battery Function

Battery Gauge

The telephone displays a battery level indicator icon in the idle screen to indicate the battery charge level.

Battery meter is 3 bars for Z6m. Battery meter is 4 bars for Z6tv

Battery Removal

Removing the battery causes the device to immediately shut down and any pending work (for example, partially entered phone book entries or outgoing messages) is lost.



If the battery is removed while receiving a message, the message will be lost.

Tools and Test Equipment

The following table lists mandatory tools and test equipment for disassembly and reassembly of Z6m/Z6tv telephones.

Table 2. General Test Equipment and Tools

Part Number ¹	Description	Application
RSX4043-A	Torque Driver	Used to remove and replace screws
—	Torque Driver Bit Torx Plus 5IP and 6IP Torx or equivalent	Used with torque driver
See Table 7	Rapid Charger	Used to charge battery and to power device
0180386A82	Antistatic Mat Kit (includes 66-80387A95 antistatic mat, 66-80334B36 ground cord, and 42-80385A59 wrist band)	Provides protection from damage to device caused by electrostatic discharge (ESD)
6680388B67	Disassembly tool, plastic with flat and pointed ends (manual opening tool)	Used during assembly/disassembly of device
6680388B01	Tweezers, plastic	Used during assembly/disassembly
	Tweezers, metal	Used during assembly/disassembly
	Disassembly pick tool	Used during assembly/disassembly
0-00-00-40876	Camera removal tool	Used for camera disassembly
0-00-00-40841 ²	Flex connector removal tool	Used for Flip and Vibrator Flex removal
0-00-00-40878 ²	Z6m/tv EL-Panel Alignment /Press Tool	Used to align the EL panel
0-00-00-40879 ²	Z6 Lens Press Fixture	Used to install the Main Lens
AMS 0-00-00-40871	Speaker press fixture	Used to install the speaker
AMS 0-00-00-40886	Z6tv/Z6m Speaker Mold (Used to install the speaker

1. To order in North America, contact Motorola Aftermarket and Accessories Division (AAD) at (800) 422-4210 or FAX (800) 622-6210; Internationally, AAD can be reached by calling (847) 538-8023 or faxing (847) 576-3023.

2. Available from AMS Software & Elektronik GmbH, c/o Holger Grube, Lise-Meitner-Straße 9 D-24941, Flensburg Tel.: +49-461-90398-0 Fax: +49-461-90398-50

3. Not available from Motorola. To order, contact Hewlett Packard at (800) 452-4844.

Disassembly

The procedures in this section provide instructions for the disassembly of Z6m/Z6tv telephones. Tools and equipment used for the phone are listed in Table 2, preceding.



Many of the integrated devices used in this equipment are vulnerable to damage from electrostatic discharge (ESD). Ensure adequate static protection is in place when handling, shipping, and servicing the internal components of this equipment.



Avoid stressing the plastic in any way to avoid damage to either the plastic or internal components.

Removing and Replacing the Battery Cover and Battery



All batteries can cause property damage and/or bodily injury, such as burns if a conductive material, such as jewelry, keys, or beaded chains touch exposed terminals. The conductive material may complete an electrical circuit (short circuit) and become quite hot. Exercise care in handling any charged battery, particularly when placing it inside a pocket, purse, or other container with metal objects.

1. Ensure the phone is turned off.
2. Slide in and hold the battery door latch, and lift the battery door up as shown in Figure 4.

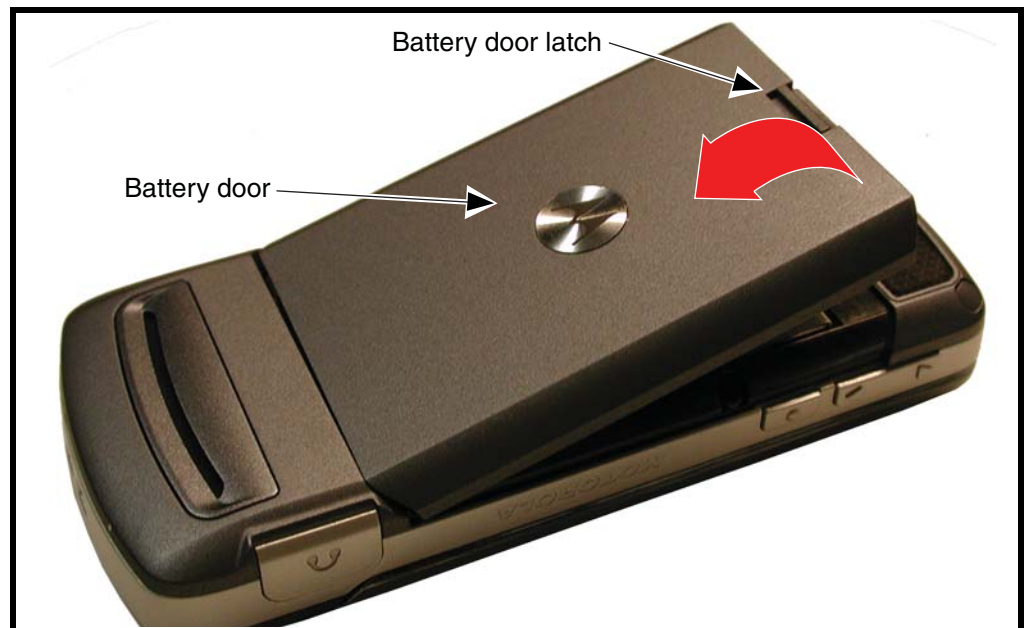

v463183

Figure 4. Removing the Battery Door

3. Lift the battery door off the phone.

4. Lift up the top edge of the battery first, then lift it completely out of the battery compartment. See Figure 5.

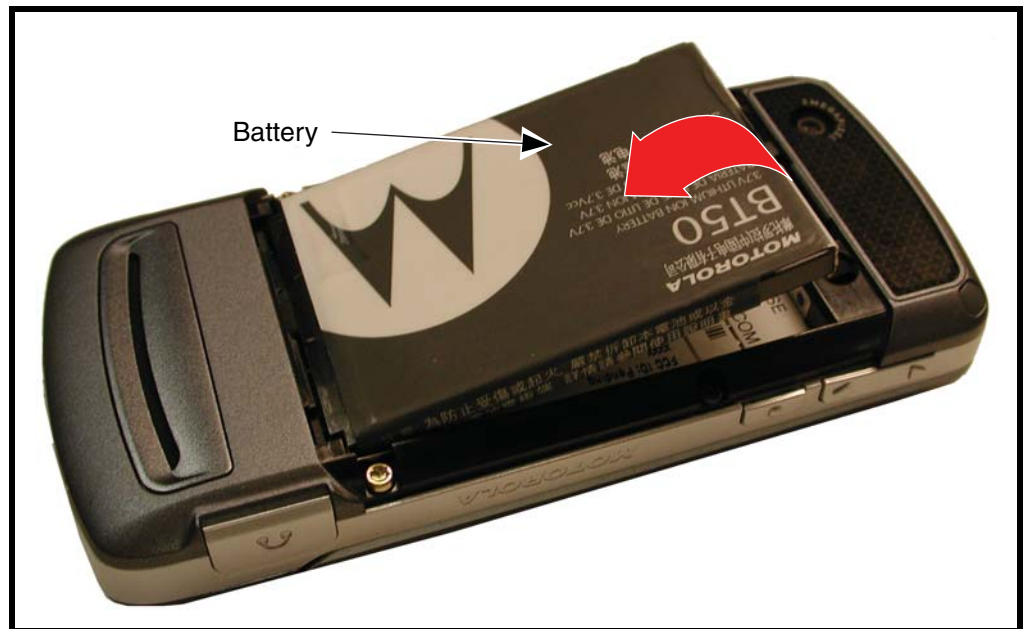

Figure 5. Removing the battery

v463188



There is a danger of explosion if the Lithium Ion battery is replaced incorrectly. Replace only with the same type of battery or equivalent as recommended by the battery manufacturer. Dispose of used batteries according to the manufacturer's instructions.

5. To replace, align the battery with the battery compartment so the contacts on the battery match the battery contacts in the phone.
6. Insert the side edge of the battery into the battery compartment, with the contacts facing downward.
7. Insert the opposite edge of the battery into the battery compartment.
8. Lower the battery cover onto the phone, and press down slightly on the cover to engage the battery latch.



Do not use the extended battery cover when using a standard battery. The battery could separate from the contacts in the battery compartment resulting in a loss of power.

Removing and Replacing the Memory Card

1. Lightly press the memory card to release and carefully slide it out, as shown in Figure 6.



v463193

Figure 6. Removing the Memory Card

2. To replace, slide the memory card into its slot with the gold contacts facing downward. The memory card can be correctly inserted only one way.
3. Replace the battery cover.

Removing and Replacing the Rear Housing



This product contains static-sensitive devices. Use anti-static handling procedures to prevent electrostatic discharge (ESD) and component damage.

1. Remove the battery cover, battery, and memory card as described in the procedures.
2. Remove the screw grommets from the corners of the phone

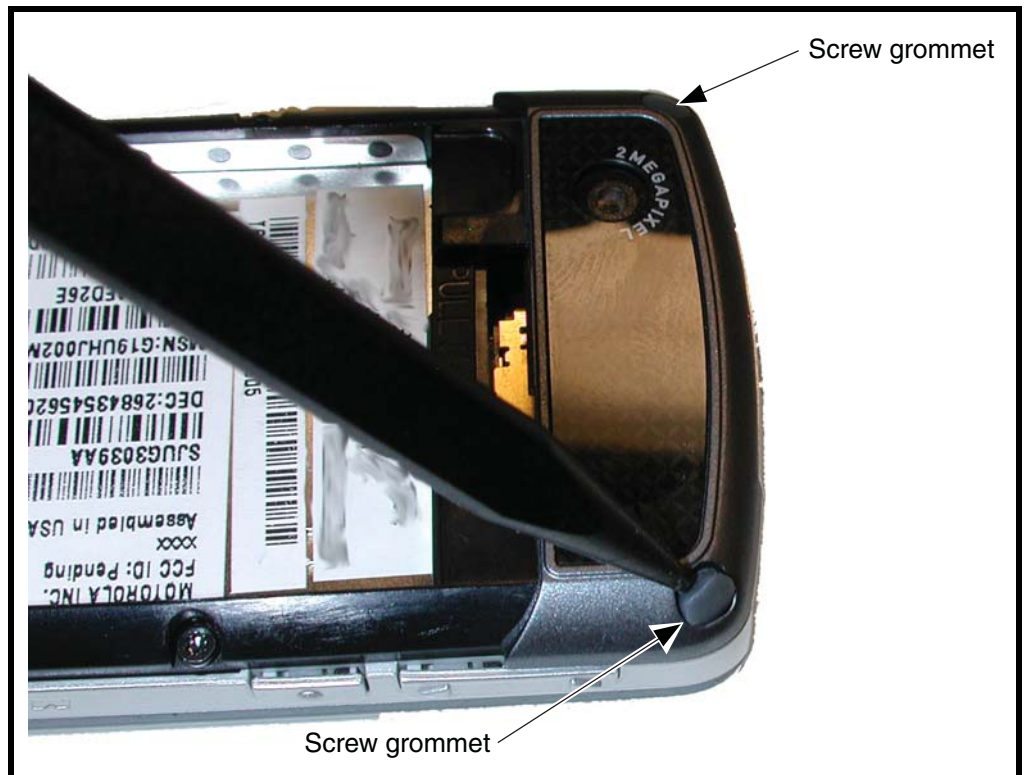
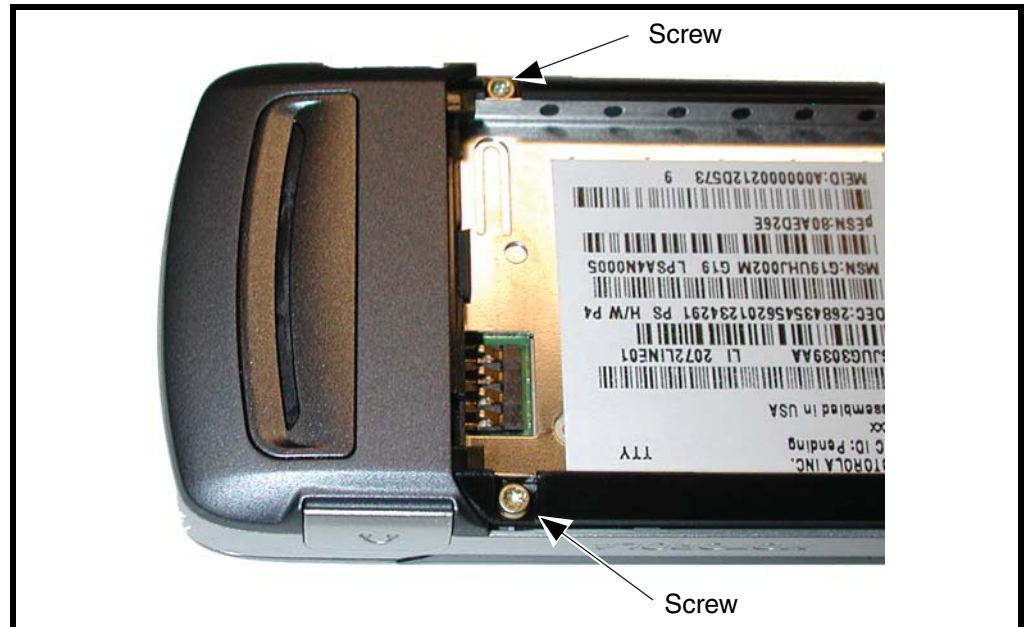

Figure 7. Removing the Rear Housing Screw Grommets

v463192

- Using a Torx driver with a Torx plus 6IP bit, remove the 2 gold thread forming screws at the sides of the rear housing. Retain the screws for reassembly. See Figure 8.



v463218

Figure 8. Removing the Thread Forming Screws

- Use the Torx plus 5IP driver to remove the 4 machine screws.

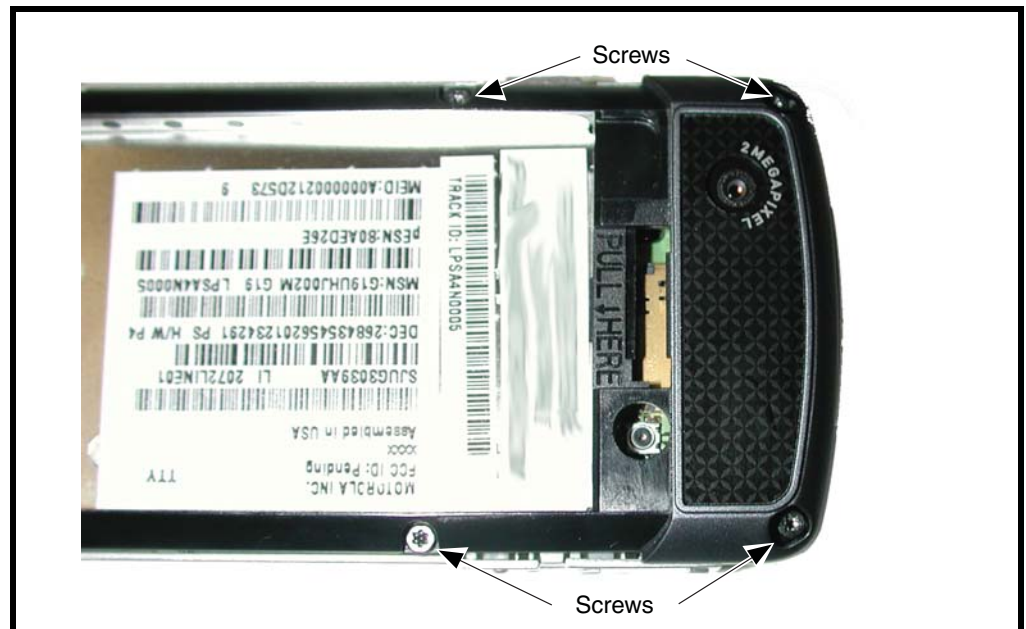

v463217

Figure 9. Removing the Machine Screws

5. Starting at the top of the phone, slightly separate the front & rear housings. Gently disengage center 2 snaps (1 on each side).

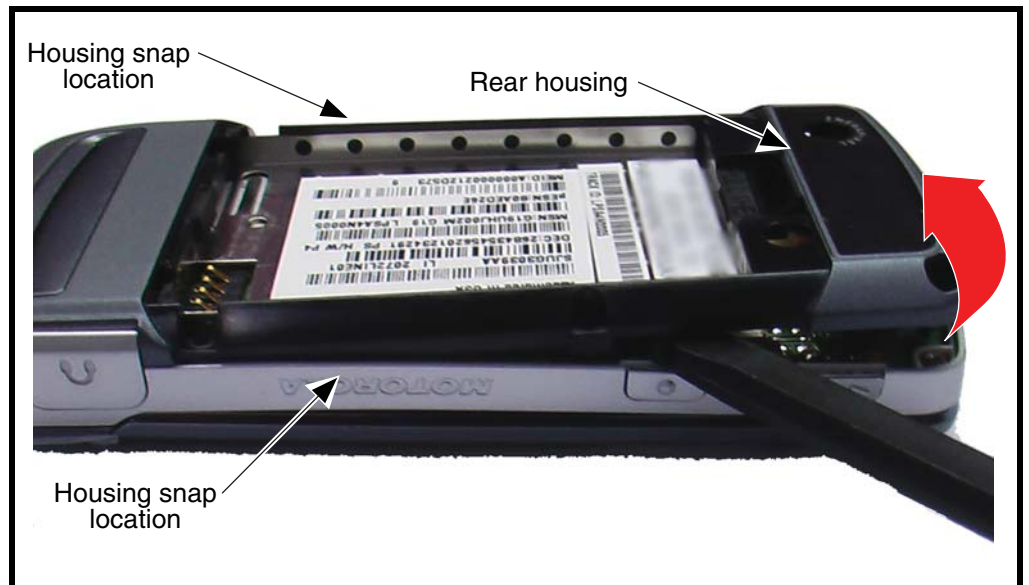

v46319

Figure 10. Releasing the Housing Snaps

6. To release the bottom 2 side snaps, start by using a disassembly pick in the location shown (access hole on either side of phone) to pry the front housing outward releasing the lower side rear housing loop. Use caution to avoid damaging the housing with the pry tool. The objective is to deflect the front housing side wall, not the rear housing loop in order to disengage the snap. Repeat for both side snaps (see Figure 11 on page 22).

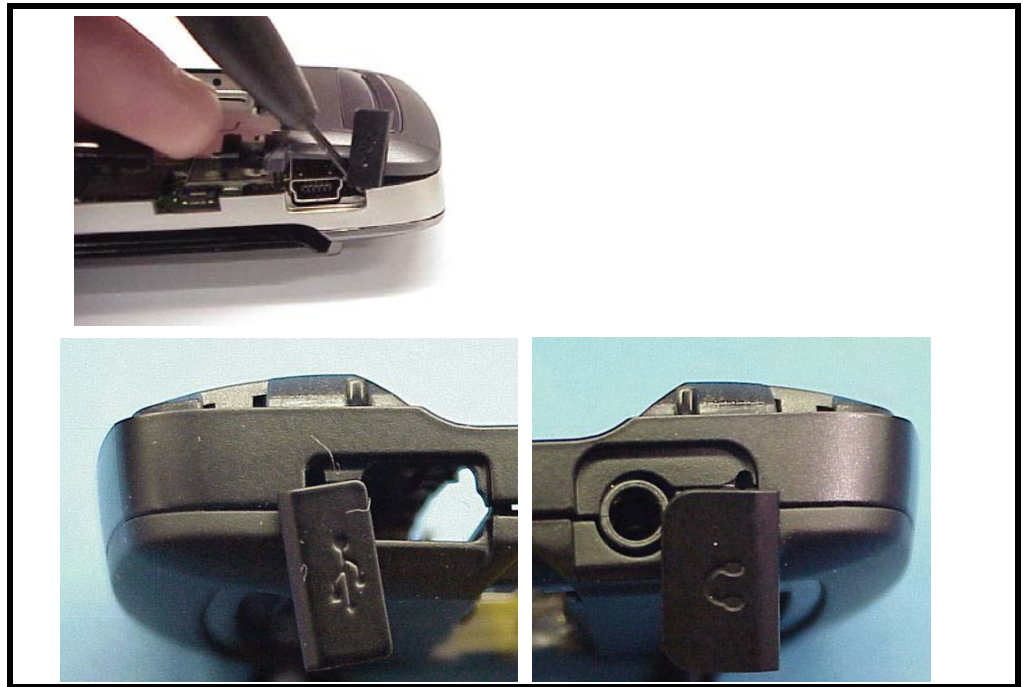

v463220

Figure 11. Removing the Rear Housing

7. The last step is to gently rotate the housings to disengage the last 2 hooks.



v463221

Figure 12. Removing the Rear Housing

8. When all the snaps are disengaged, carefully lift the rear housing straight up and away from the phone.
9. To replace, carefully align the top of the front and rear housings.
10. Press to engage the middle snaps on the front and rear housings until the catches snap into place.
11. Press to engage the bottom hooks.
12. Install the 4 machine screws and tighten with a Torx plus 5IP driver to a final torque setting of 1.0 lbf in. Install the screws in the order shown below. Do not over tighten.

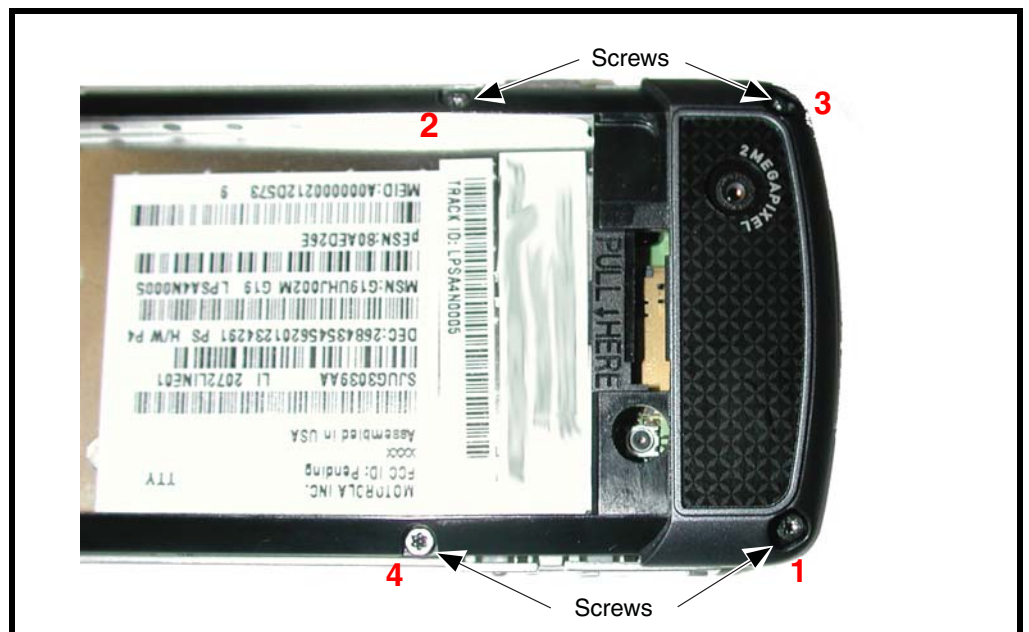

v463217

Figure 13. Installing the Machine Screws

13. Install the 2 thread forming rear housing screws and tighten with the Torx plus 6IP driver to a final torque setting of 1.2 lbf in. Do not over tighten.
14. Install the 2 screw grommets at the top of the rear housing.
15. Install the speaker cover on the rear housing.
16. Replace the battery, and battery cover as described in the procedures.

Removing and Replacing the Transceiver Board Assembly



This product contains static-sensitive devices. Use anti-static handling procedures to prevent electrostatic discharge (ESD) and component damage.

1. Remove the battery cover, battery, memory card, antenna, rear housing as described in the procedures.



The flexible printed cable (FPC) (flex) is easily damaged. Exercise extreme care when handling.

2. Carefully slide the end of the disassembly tool under the slider Hydra Flex (HF) connector and rotate the tool slightly to lift the connector from its socket on the transceiver board. See Figure 14. Pay special attention to the electrical components around the connector. **Do not touch any components with the black stick.**

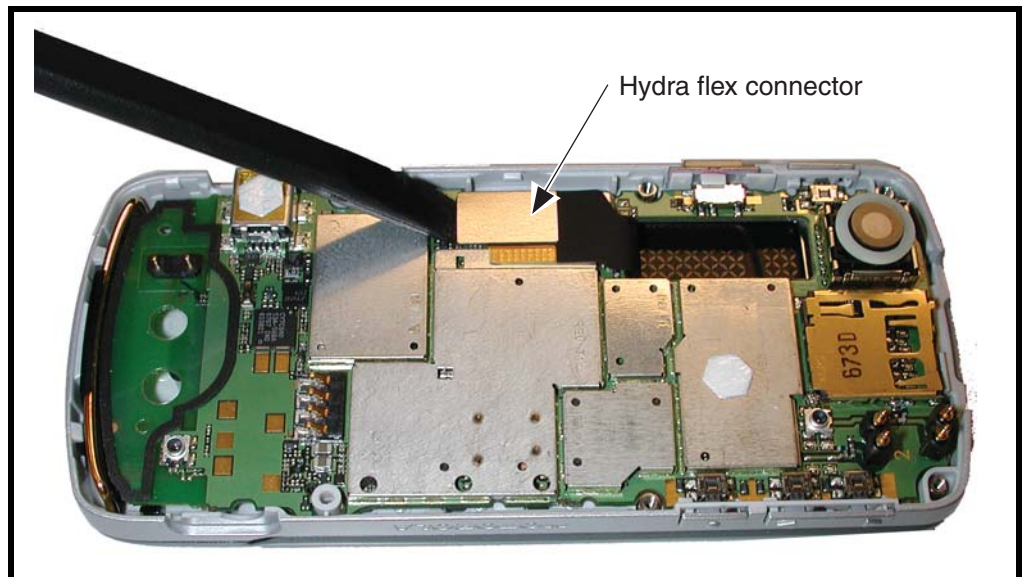

v463258

Figure 14. Disconnecting the Flex From the Transceiver Board

3. Remove the “Hold” button from the front housing.

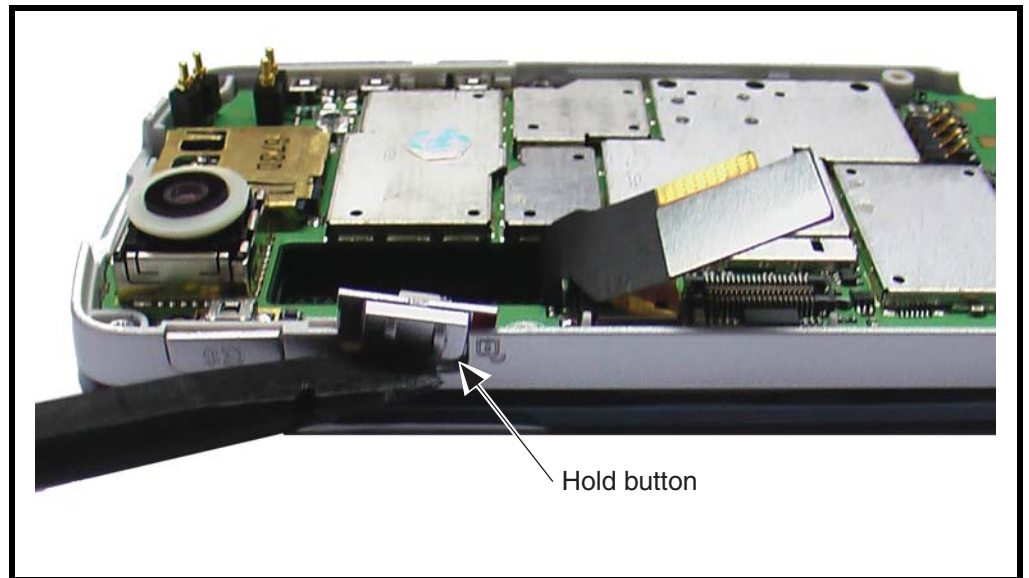

v463259

Figure 15. Removing the Hold Button From the Rear Housing

4. Remove Slider assembly.
5. Remove the 3 side keys from the front housing. Use the disassembly tool to deflect the small key leg just enough to unhook it from the housing. Once unhooked, the key can be easily removed from the front housing.

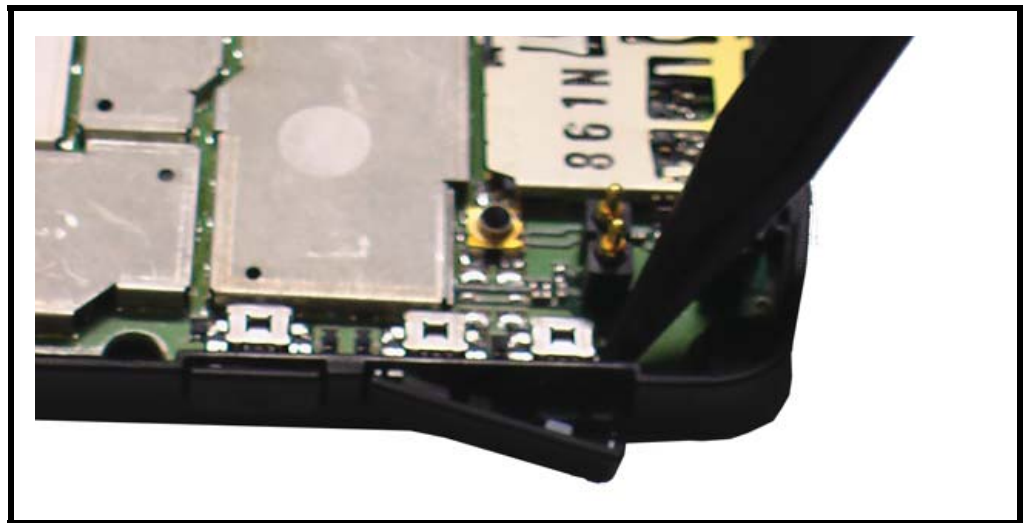

v463336

Figure 16. Removing the Side Keys

- Carefully lift the transceiver board out of the front housing (see Figure 17).

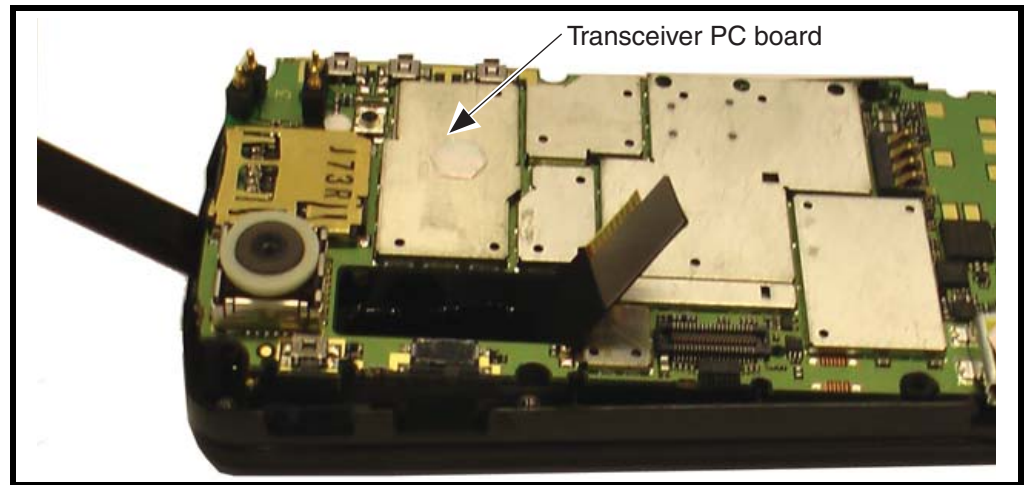

v527801

Figure 17. Removing the Transceiver PC Board Assembly

- To replace, install the slider assembly and then insert the transceiver board assembly into the front housing with the hydra flex connector on top of the transceiver PC board assembly.

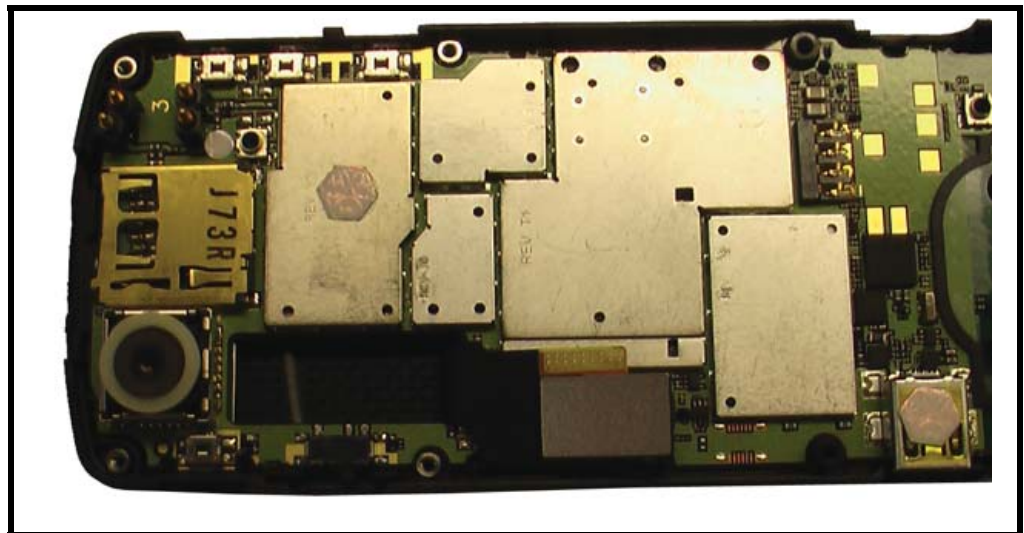

v527800

Figure 18. Installing the Transceiver PC Board

- Install the side buttons in the housing.

▶ *Be sure the volume / smart / hold buttons and voice button are correctly positioned in relation to the corresponding switches on the transceiver board. Verify operation of the buttons after replacing the transceiver board and rear chassis assembly.*

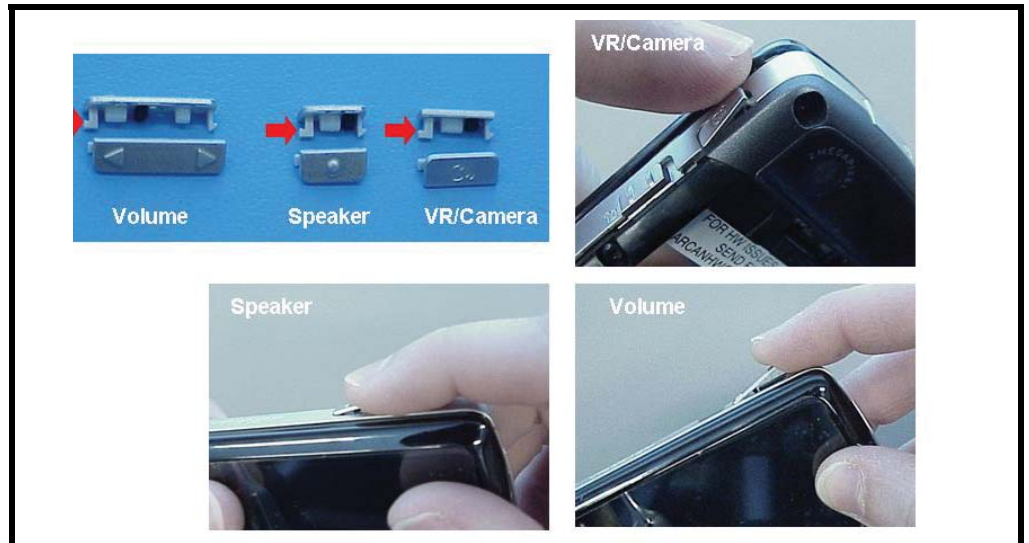

v513337

Figure 19. Installing the Side Buttons

9. Insert the hydra flex connector squarely into its mating connector on the transceiver board and press gently but firmly until it snaps into place.

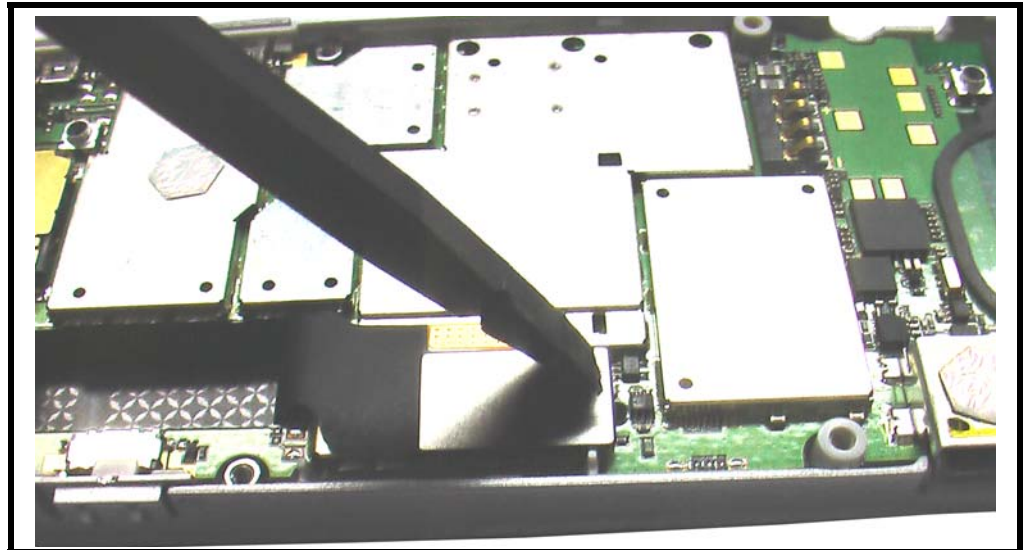

v463345

Figure 20. Connecting the Hydra Flex Connector

10. Replace the rear housing, memory card, battery, and battery cover as described in the procedures.

Removing and Replacing the Keypad

1. Remove battery cover, battery, memory card, rear housing, and transceiver board assembly as described in the procedures.
2. Lift the keypad assembly, away from the front housing assembly (see Figure 21).

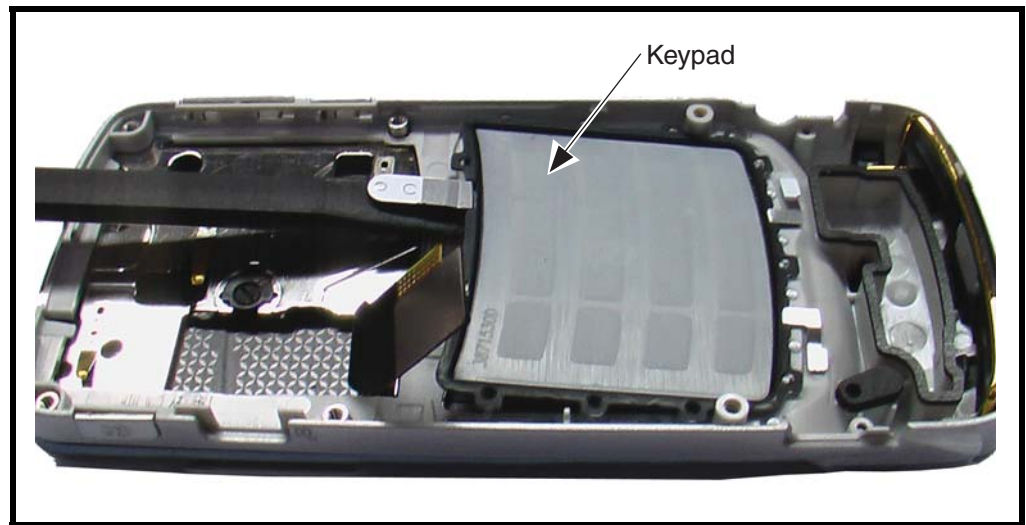

v463281

Figure 21. Removing the Keypad

3. Lift the front housing assembly away from the slider assembly. Avoid damage to the hydra flex.

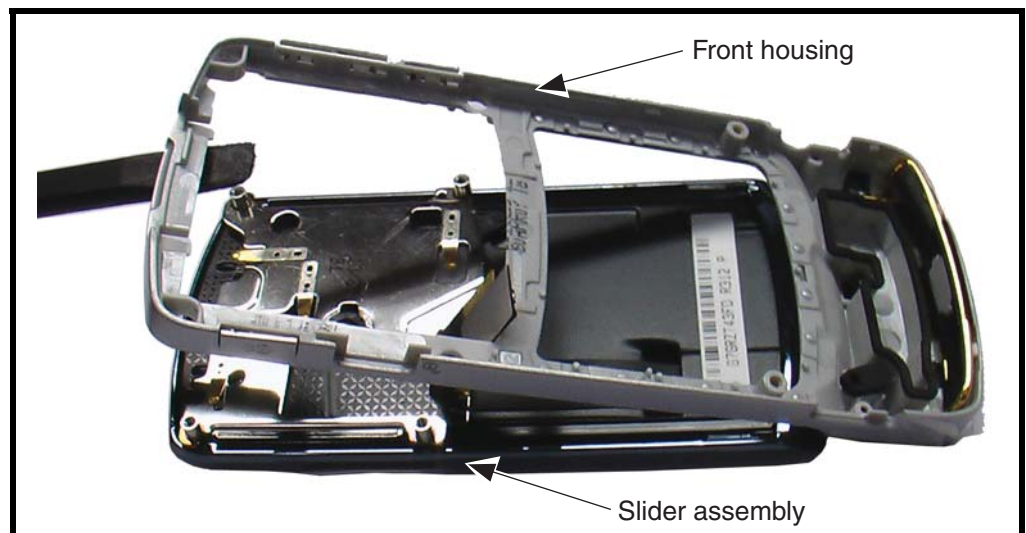

v463282

Figure 22. Removing the Front Housing

4. To replace, carefully set the keypad assembly into the front housing assembly. Ensure the volume/smart key keypads will contact the switchdome assembly on the transceiver board when installed.
5. Insert the keypad into the front housing, use the guide pins molded into the front housing to ensure the keypad is placed correctly.

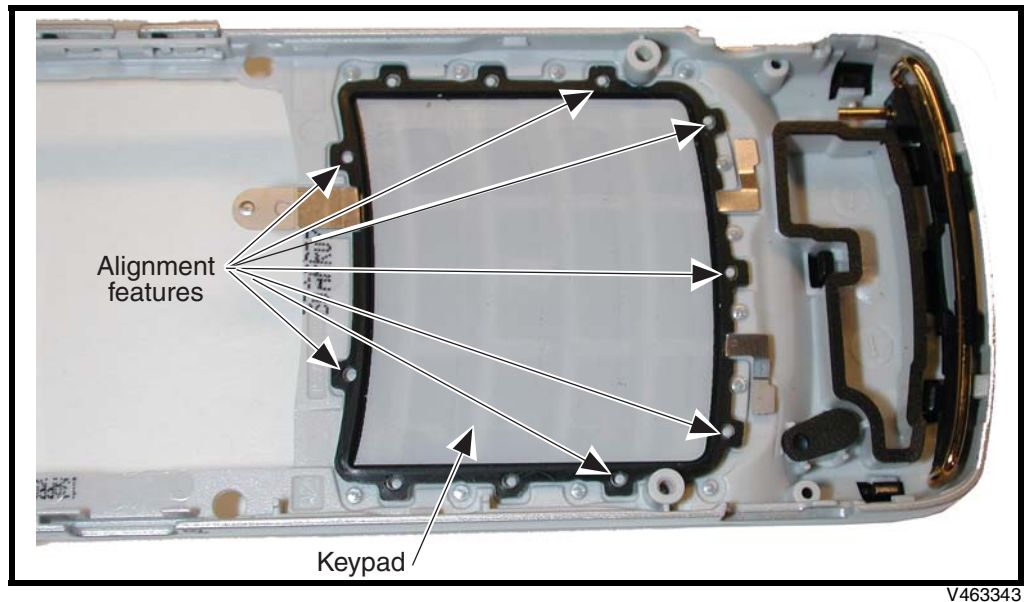

Figure 23. installing the Keypad

6. Replace the transceiver board assembly, rear housing assembly, memory card, battery, and battery cover as described in the procedures.

Removing the Rear Housing Components

1. Remove battery cover, battery, memory card, rear housing, as described in the procedures.



The hydraflex can be easily damaged. Use extreme caution during this next step.

Memory Card Cover Remove and Replace

1. Use the disassembly tool to remove the microSD memory card cover.

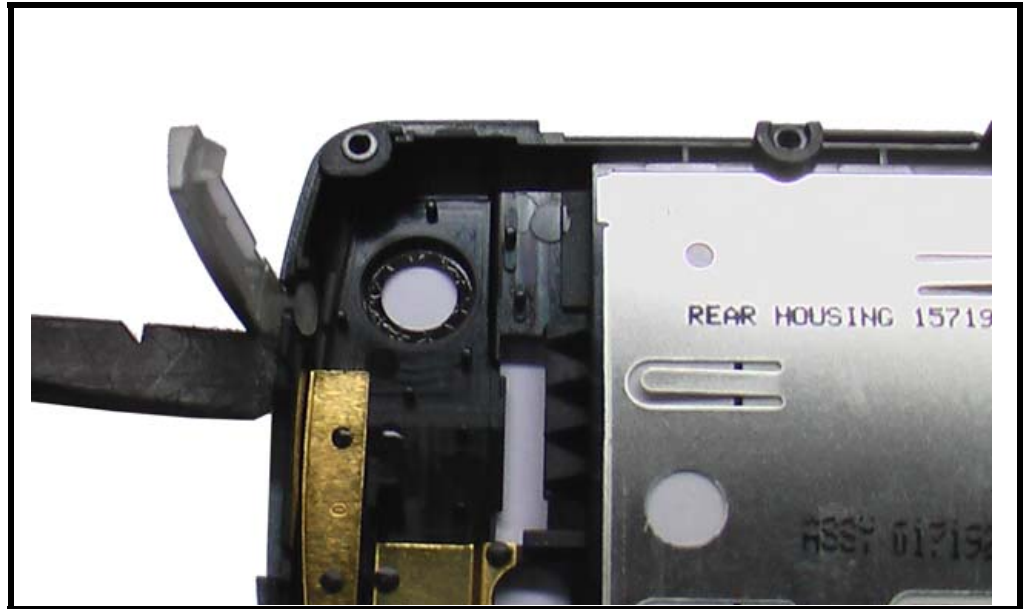

v463286

Figure 24. Removing the Memory Card Cover

2. To replace, insert the memory card cover into the notch in the rear housing.

Vibrator Assembly Remove and Replace

1. Use the disassembly tool pick to pry the vibrator assembly from its location in the rear housing.

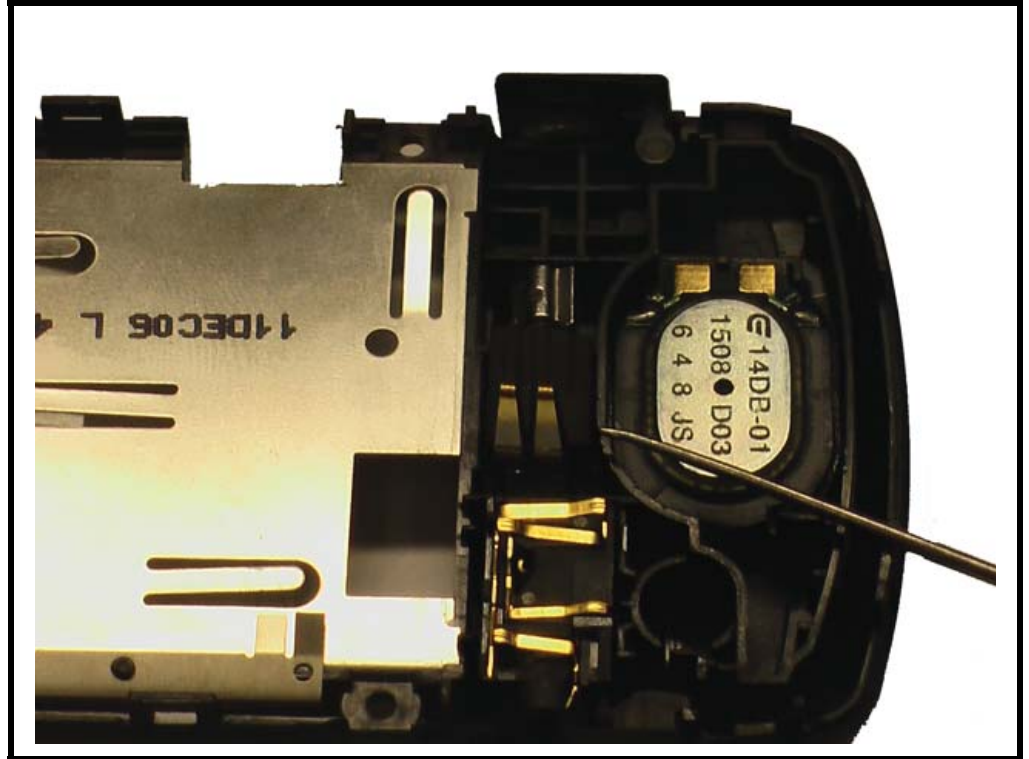

v463287

Figure 25. Removing the Vibrator Assembly

2. To replace, insert the vibrator assembly into its location in the rear housing.

Headset Grommet Remove and Replace

1. Use the disassembly tool to remove the headset grommet from the rear housing.

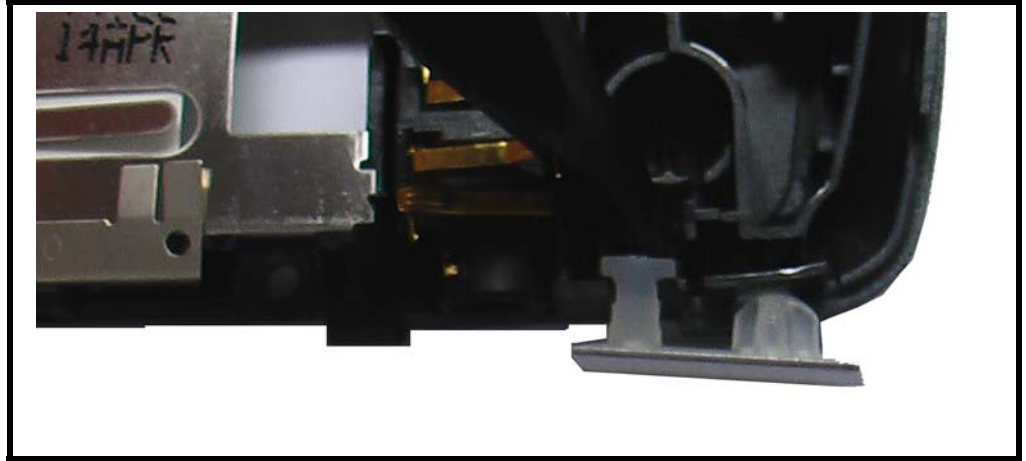

v463288

Figure 26. Removing the Headset Grommet

2. To replace, carefully press the headset grommet into the notch in the rear housing.

Headset Connector Remove and Replace

1. Insert black stick between the headset jack and housing and pry it away.

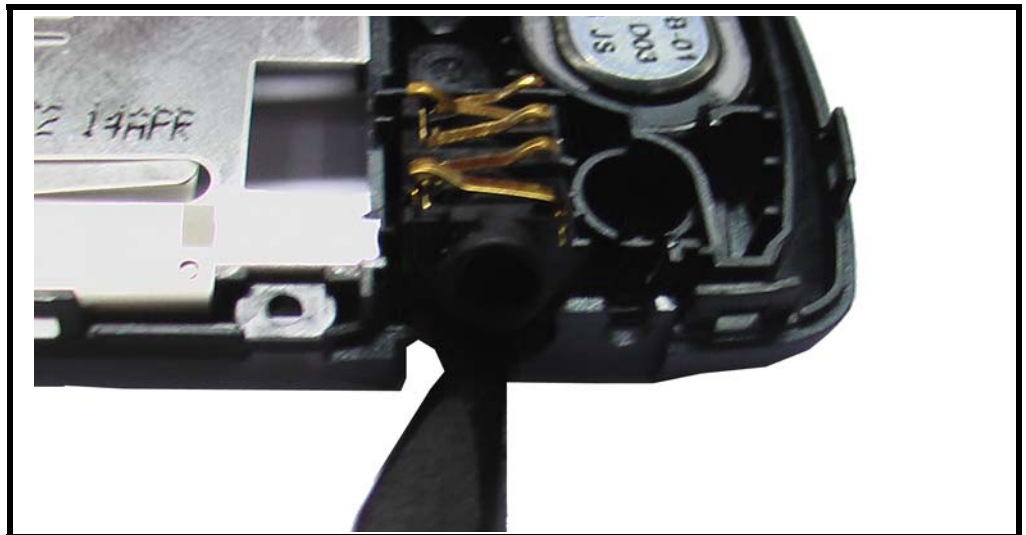

V463289

Figure 27. Removing the Headset Connector

2. To replace first place the adhesive, then align and place the headset connector.

Speaker Cover Remove and Replace

1. Remove the battery cover, battery, memory card, and rear housing as described in the procedures.



Use extreme care not damage the speaker during the removal of the cover.

2. If it is necessary to replace the speaker cover, use the disassembly tool to remove the speaker cover from the rear housing.



0703730

Figure 28. Removing the Speaker Cover

3. Remove any remaining adhesive residue from the rear housing. Discard the speaker cover. Do not reuse.
4. To replace, expose the adhesive surface on the new speaker cover.
5. Press the speaker cover onto the rear housing.
6. Replace the memory card, battery, and battery cover as described in the procedures.

Speaker Remove and Replace

1. Insert black stick between the housing and speaker and pry it away.

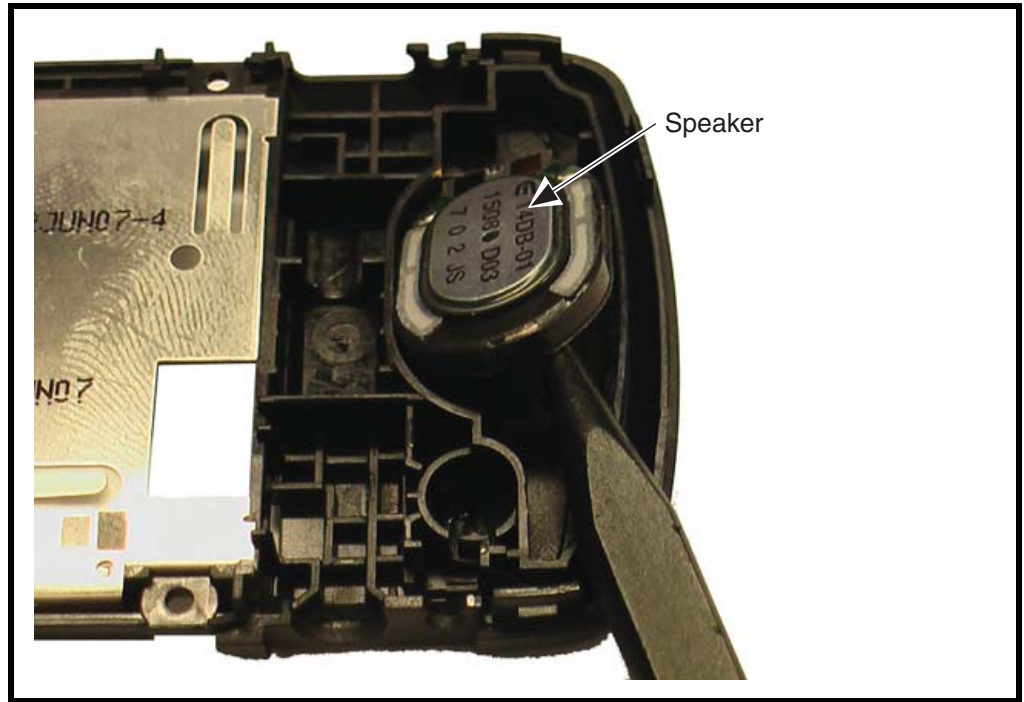

0703730

Figure 29. Removing the Speaker

2. To replace first place the adhesive, then align and place the speaker.

3. Place rear housing on speaker press and set it to 20N, press and hold for 5 seconds.



v527823

Figure 30. Using the Speaker Press

Camera Remove and Replace

1. Use the disassembly tool to remove the camera retaining ring from the camera assembly on the transceiver PC board.

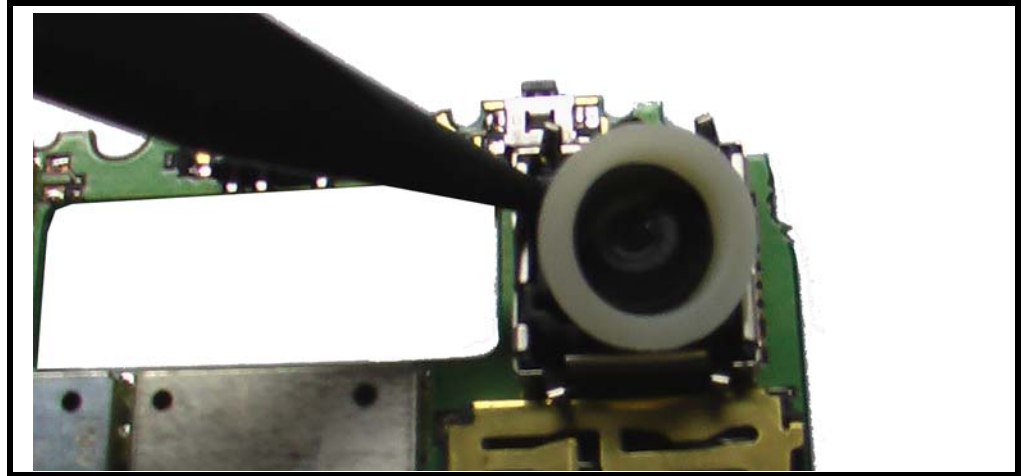

v463331

Figure 31. Removing the Camera Assembly Retaining Ring

2. Use the camera disassembly tool to remove the camera assembly from the imager socket on the transceiver PC board.

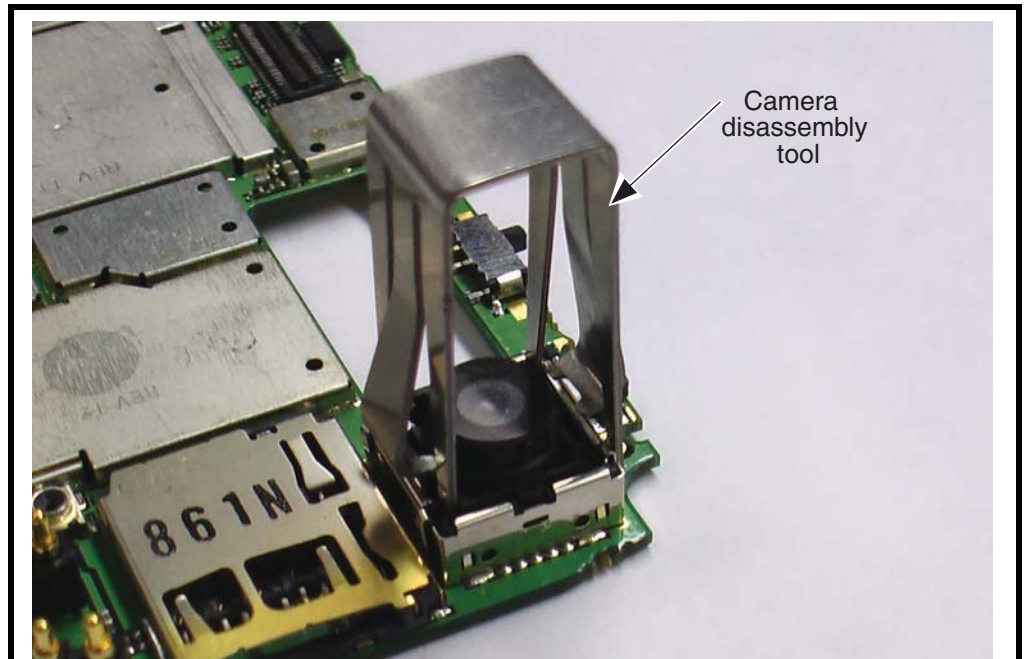

v513338

Figure 32. Removing the Camera Assembly

3. To replace, align the key on the camera assembly to the key slot on the on the imager socket. Do not remove the protective liner from the camera assembly.

4. Press the camera assembly down into the socket until it is fully seated.

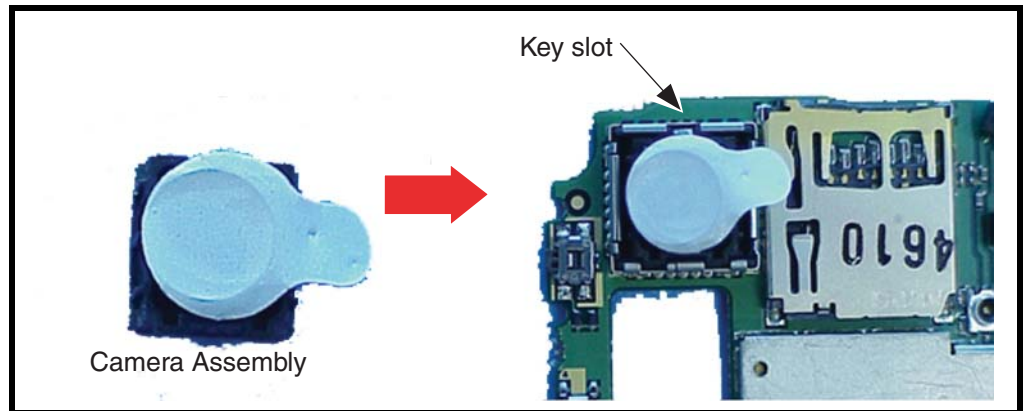

Figure 33. Replacing the Camera Assembly

5. Remove the protective liner and place the camera retention ring onto the camera assembly.

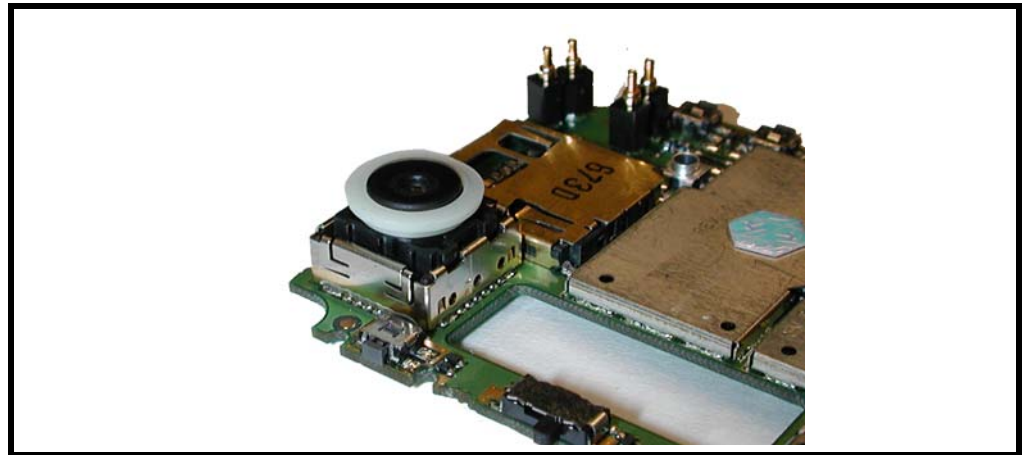

Figure 34. Installing the Camera Assembly

6. Replace the protective liner onto the camera assembly.

Removing and Replacing the Slider Assembly

1. Remove battery cover, battery, memory card, rear housing, daughter board assembly, transceiver board assembly, keypad, and front housing as described in the procedures.



The hydraflex can be easily damaged. Use extreme caution during this procedure.

2. Use the T5 driver to remove the 2 slider screws from the slider assembly.

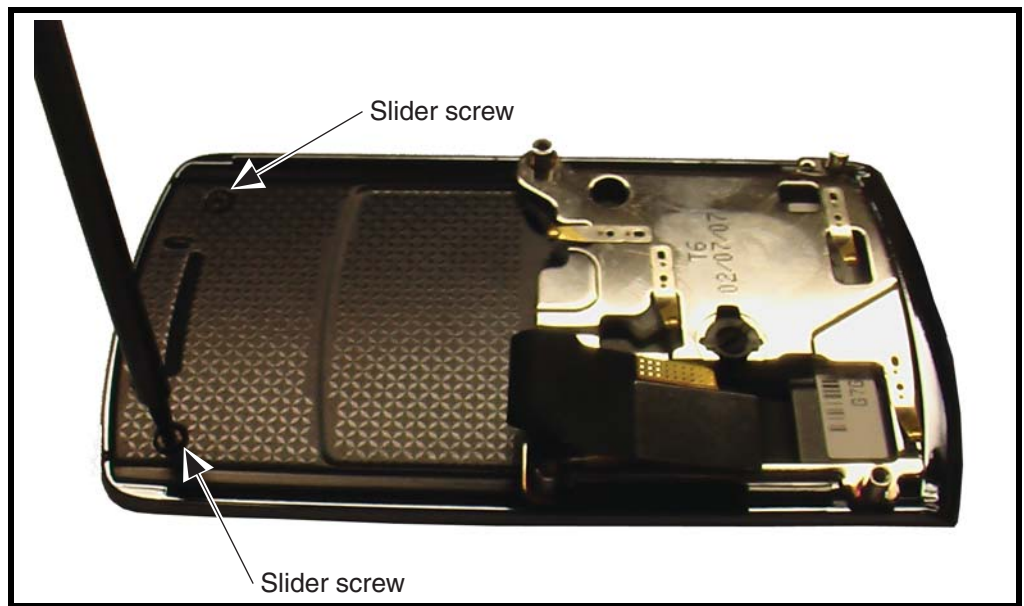

v463353

Figure 35. Removing the Slider Assembly Screws

3. Use the disassembly tool to lift only the top end of the slider inner assembly out of the slider outer assembly. Leave the bottom end attached.
4. Rotate the slider outer assembly upward, to expose the keypad flex connector which is still attached to the slider outer assembly (see Figure 36 on page 39).



When removing the slider, ensure that the earpiece is not damaged because of any remaining adhesive.

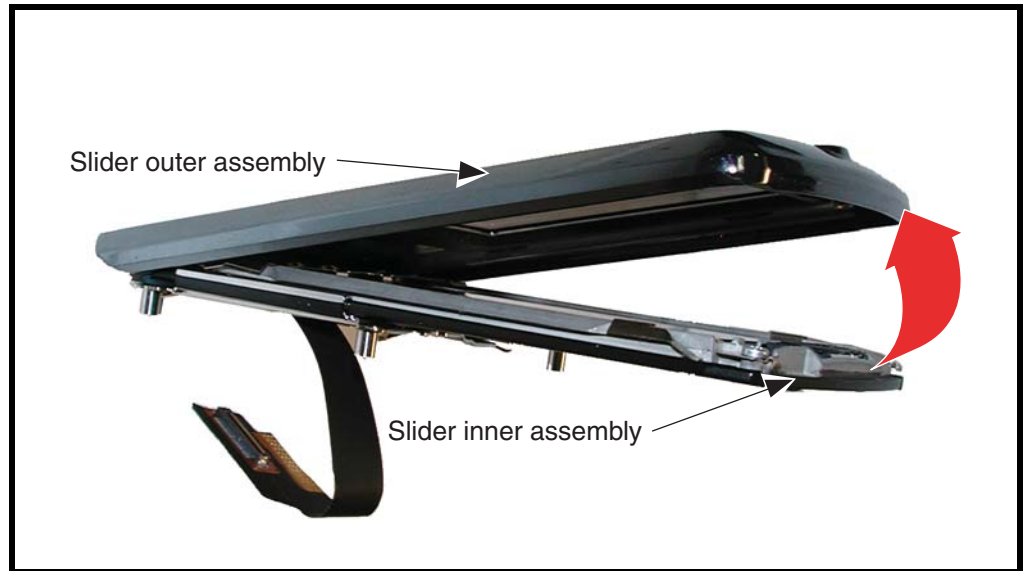

v463354

Figure 36. Separate the Slider Inner and Outer Assemblies

5. Use the camera disassembly tool to unseat the keypad flex connector. Ensure the electrical components near the connector are not damaged.

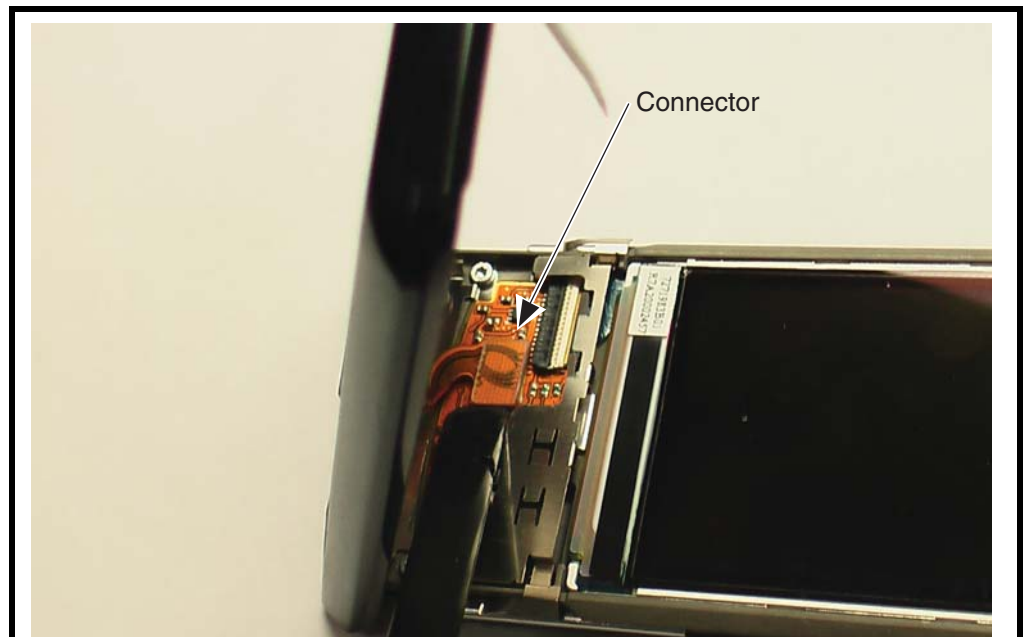

v513339

Figure 37. Removing the Slider Assembly Connector

6. Remove the slider outer assembly.

7. Remove the two lower ground clip screws.

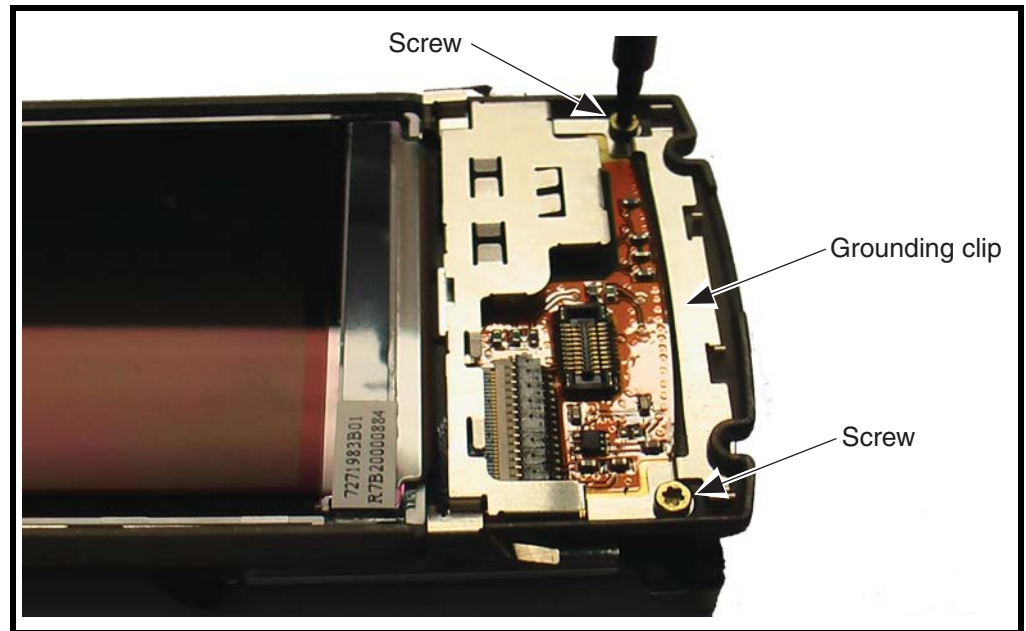

v463358

Figure 38. Removing the Lower Ground Clip Screws

8. Remove the lower ground clip.
9. Remove the upper ground clip screws.

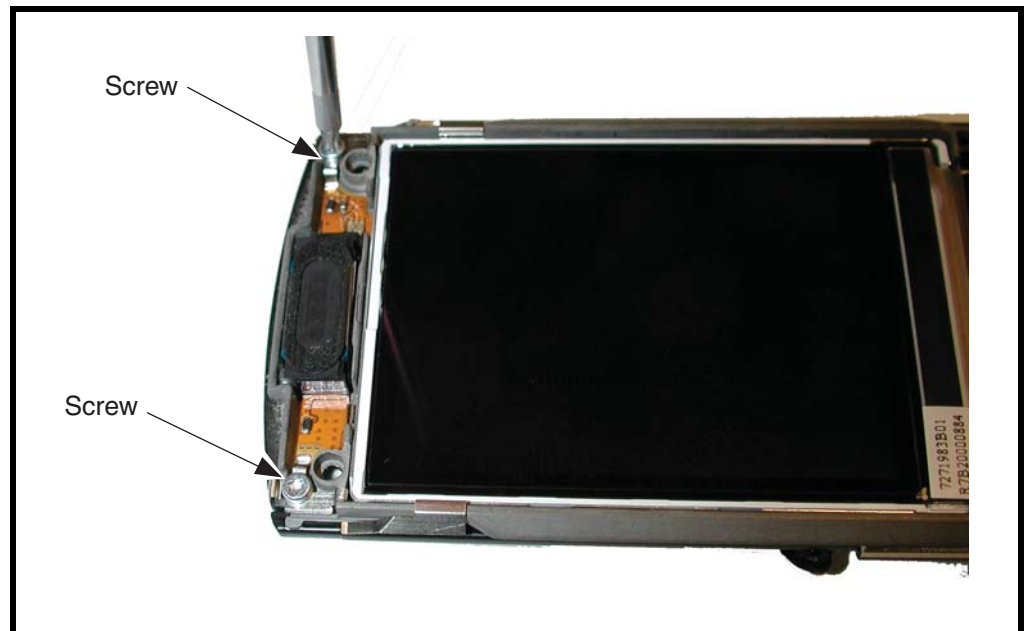

v463359

Figure 39. Removing the Upper Ground Clip Screws

10. Use the disassembly tool to unlock the ZIF connector.

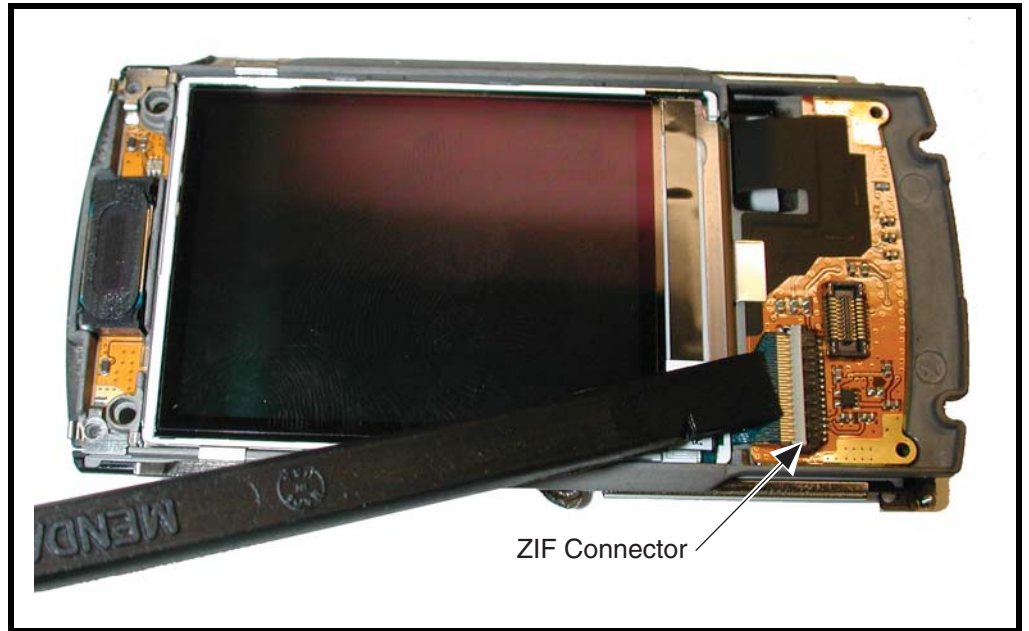

v463369

Figure 40. Unlocking the ZIF Connector

11. Rotate the display upward.

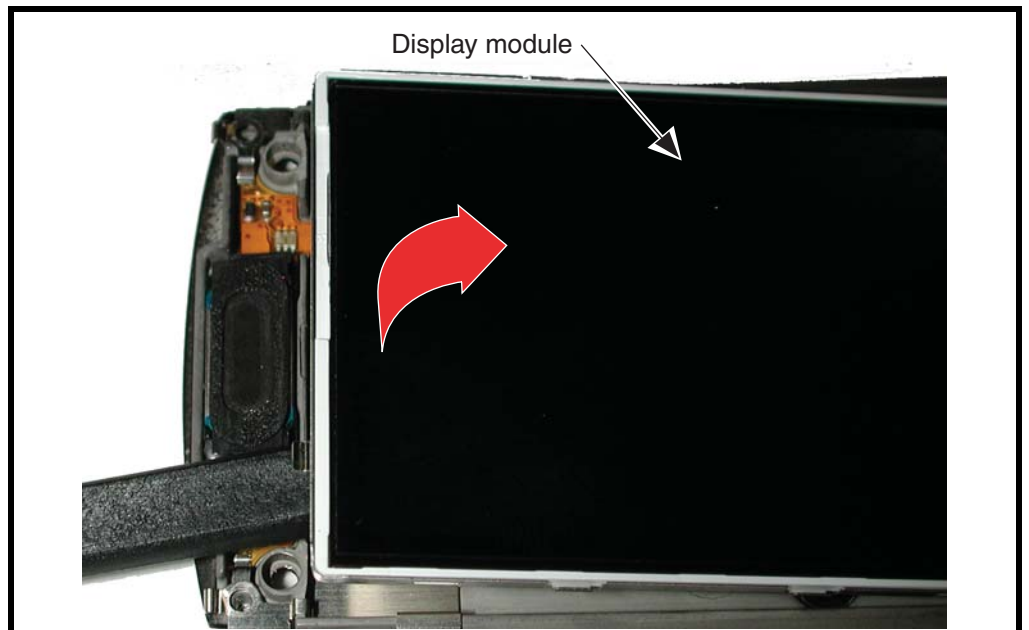

v463376

Figure 41. Removing the Display Module

12. Separate the flex cable from the ZIF connector and remove the display module (starting from the top) from the slider starting at the top.
13. Remove the upper ground clip.

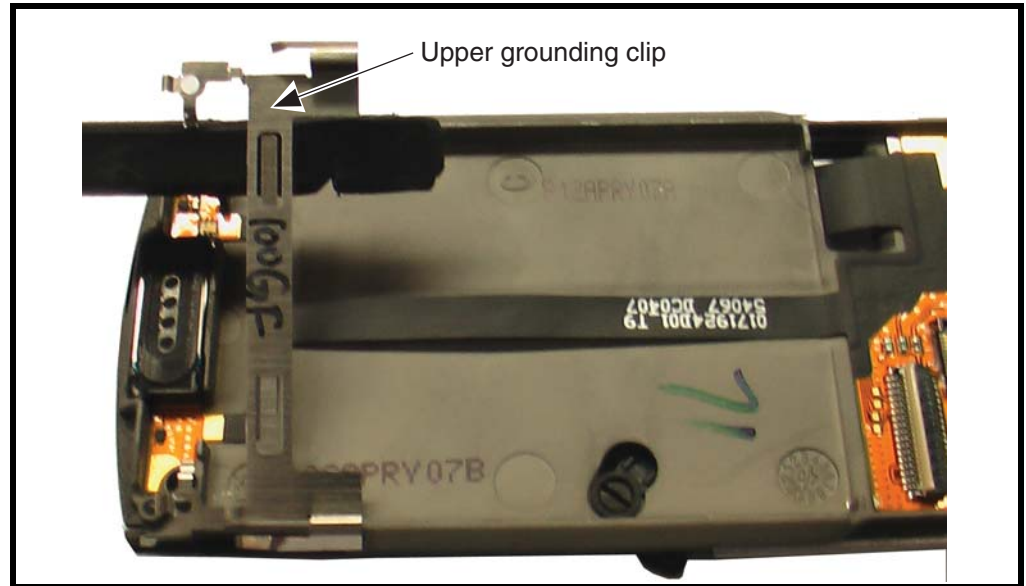

v463378

Figure 42. Removing the Upper Ground Clip

14. Remove the Hydrflex.



v463379

Figure 43. Removing the Hydrflex

15. Lift the Hydrflex out of the slider assembly.

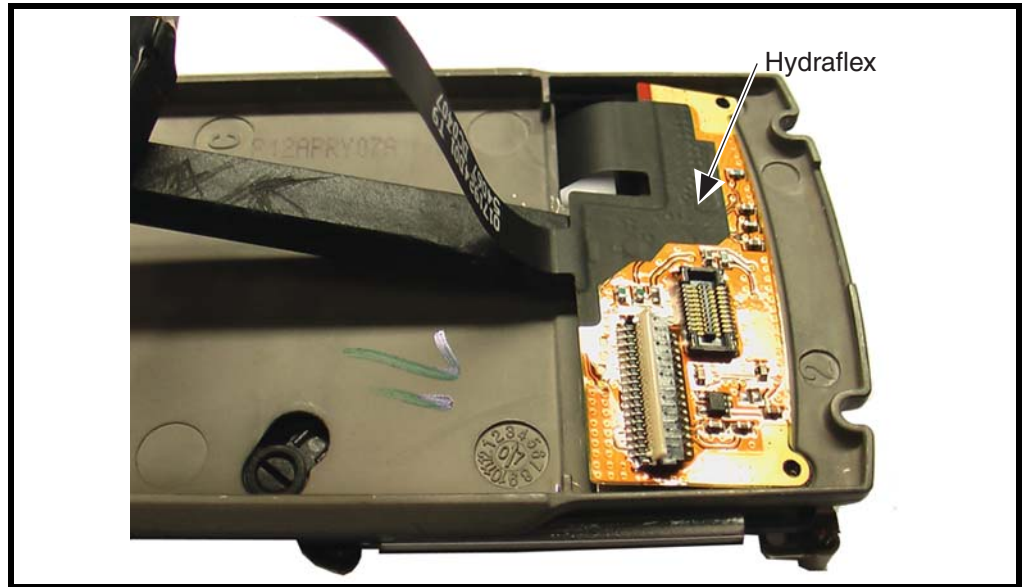

v463380

Figure 44. Removing the Hydrflex

Removing the Slider Mechanism

16. Use the disassembly tool to slide the slider arm as shown.

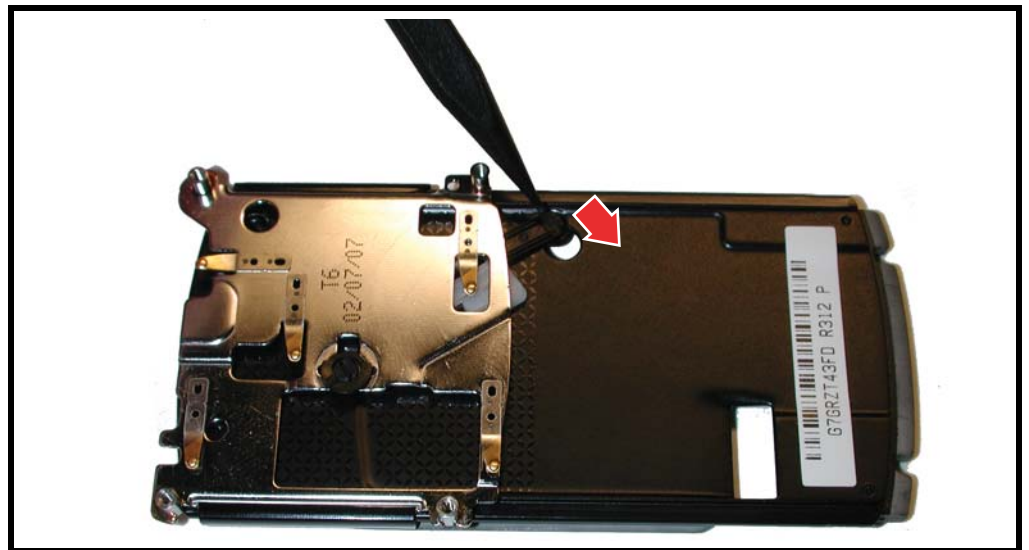

v463381

Figure 45. Removing the Slider Mechanism Part 1

17. Lift the slider arm out of the retaining hole and slide it to the center of the slider assembly as shown.

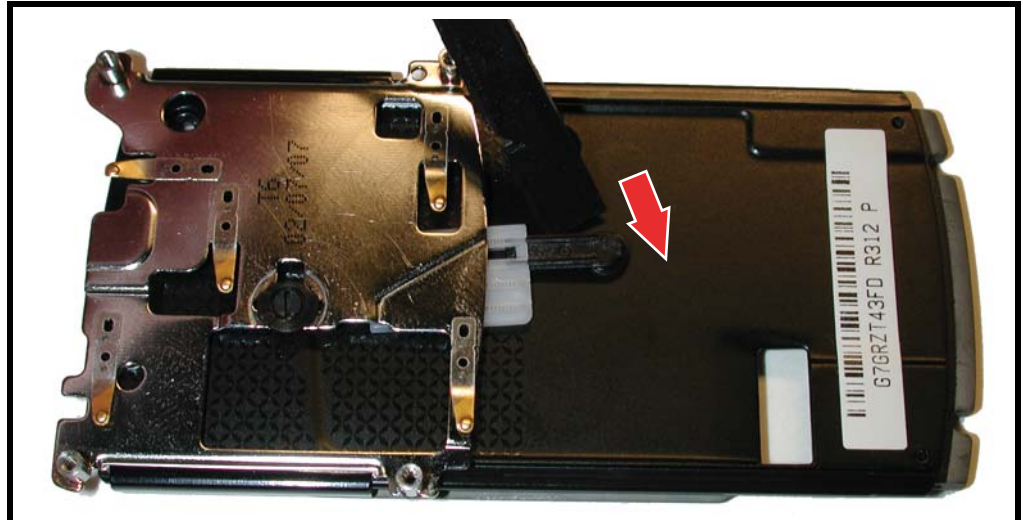

v463382

Figure 46. Removing the Slider Mechanism Part 2

18. Slide the slider mechanism all the way to the left as shown to separate it from the slider assembly.

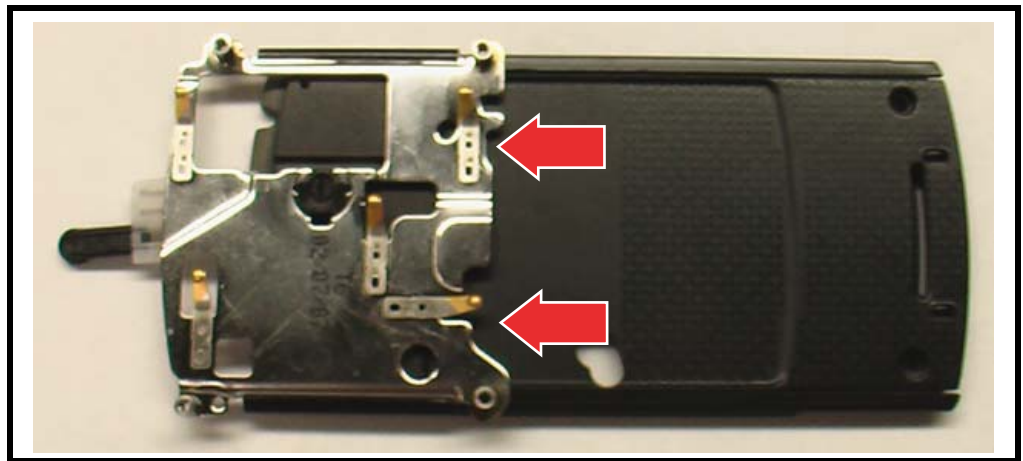

v463383

Figure 47. Removing the Slider Mechanism Part 3

19. Separate the slider arm (Spring Actuator with bushings) out of the retaining hole on the guide metal. (Discard slider arm)
20. Separate the rails out of the slide inner assembly. (Discard the rails)

21. To replace, use rail combination 2.

Rail Combinations		
	Left Rail of Slide inner	Right Rail of Slide inner
Rail Combination 1	Thick Rail 4671633E	Thick Rail 4671633E
Rail Combination 2	Thick Rail 4671633E	Thin Rail 4671734E
Rail Combination 3	Thin Rail 4671734E	Thin Rail 4671734E

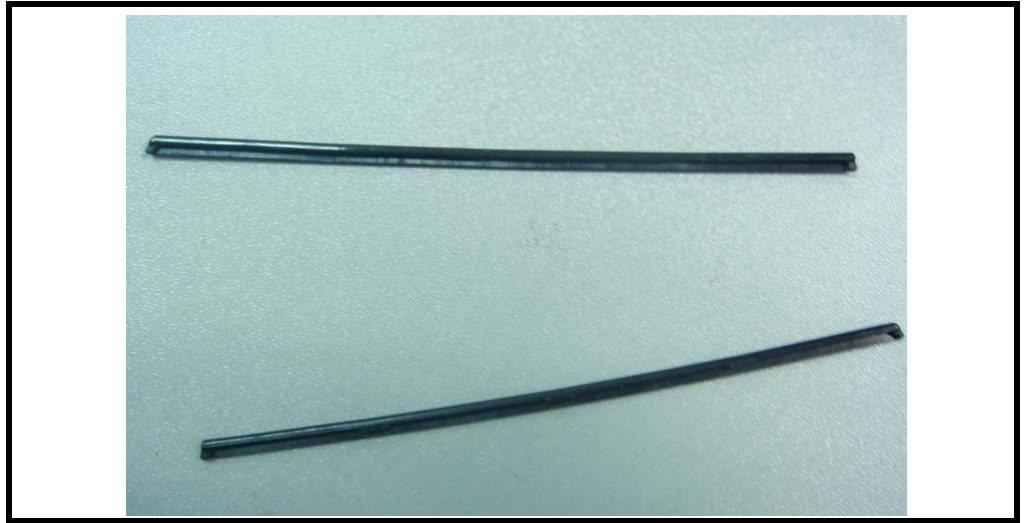

v463385

Figure 48. Slider Rails

22. Assemble rail combination 2 on slider inner assembly.



Figure 49. Rail Assembly on Slider Inner Assembly

23. Assemble guide metal assembly to slide inner assembly.

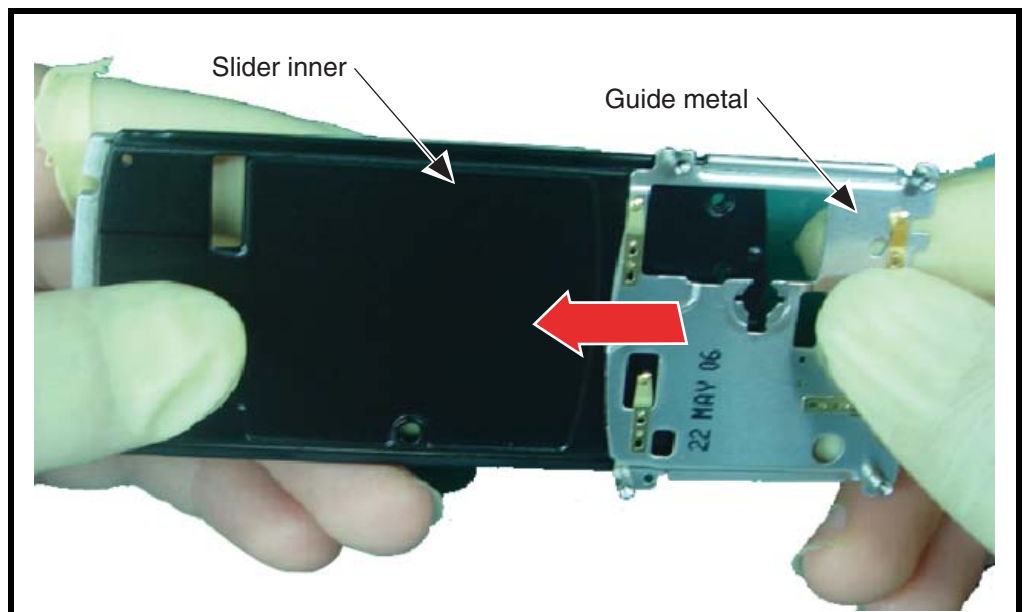

Figure 50. Guide Metal Assembly to Slide Inner Assembly

v487265

24. Perform gravity test 1. Place the slider assembly in position 1 and let the guide metal assembly slide freely along the slide inner assembly. If the guide metal falls completely to position 2, the assembly passes. Proceed to gravity test 2. If not, proceed to step 26.



v487351

Figure 51. Gravity Test 1

-
25. Perform gravity test 2. Place the slider assembly in position 2, and let the guide metal assembly slide freely along the slide inner.



v487352

Figure 52. Gravity Test 2

26. If gravity tests 1 and/or 2 failed, replace the rails with rail combination 3 and repeat gravity tests 1 and 2 beginning at step 24.

27. Place the bushing into the spring actuator. Figure 53 shows the correct placement.

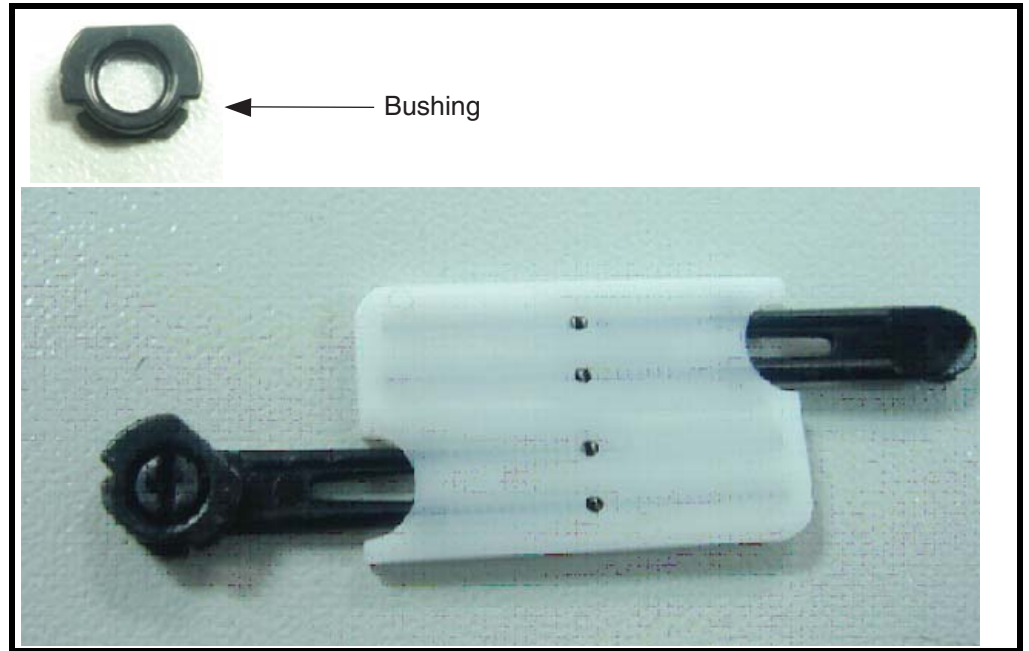

v487561

Figure 53. Bushing Placed in Spring Actuator

28. Assemble slider arm (bushing and spring actuator) into guide metal assembly. Figure 54 shows the correct placement.

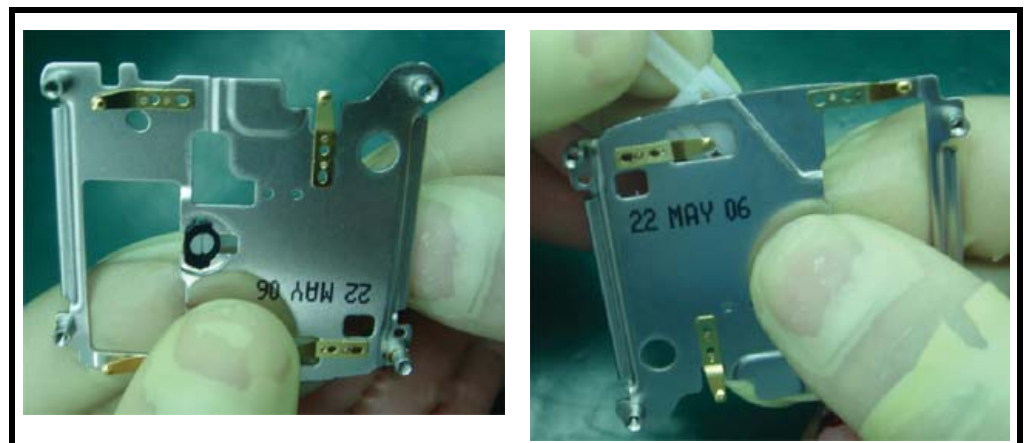

v487588

Figure 54. Slider Arm Assembly

29. Assemble the guide metal assembly to the slider inner assembly.

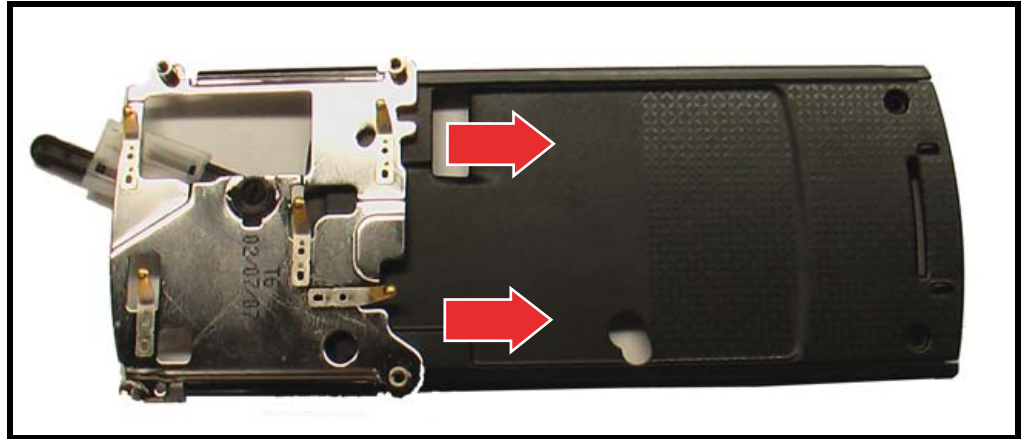

Figure 55. Slider inner Assembly

v487604

30. Apply lubricant Nygel 744 or equivalent, to slider rails.

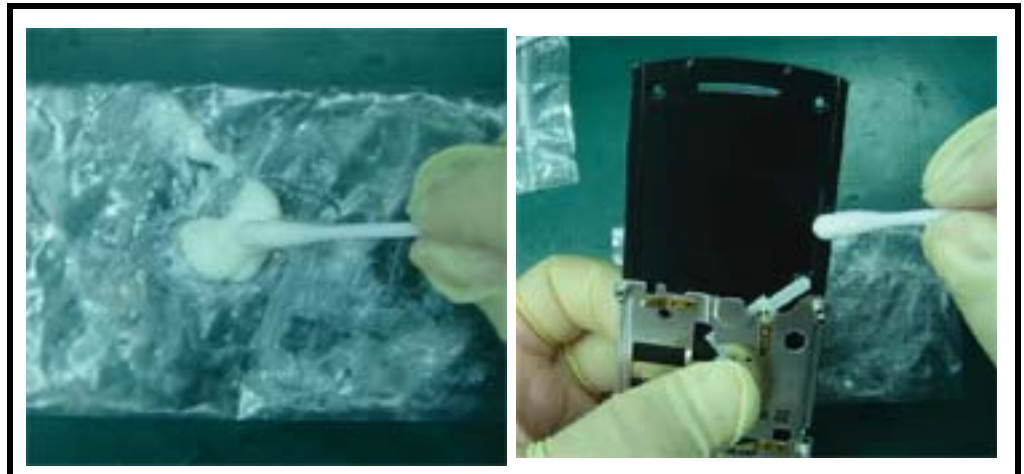

Figure 56. Lubricating Slider Rails

v487605

31. Use the disassembly tool to remove the main lens.



v503130

Figure 57. Removing the Main Lens

32. Use the disassembly tool to unbend the keypad tabs.

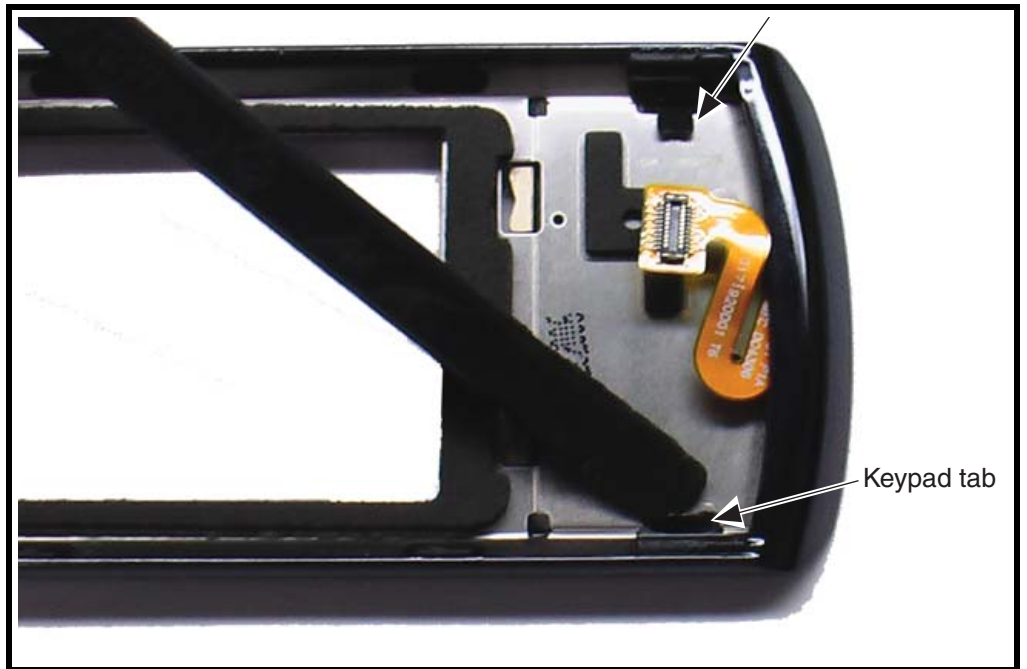

Keypad tab

v463385

Figure 58. Unbending the Keypad Tabs

33. Lift the slider keypad up then remove it from the slider as shown.

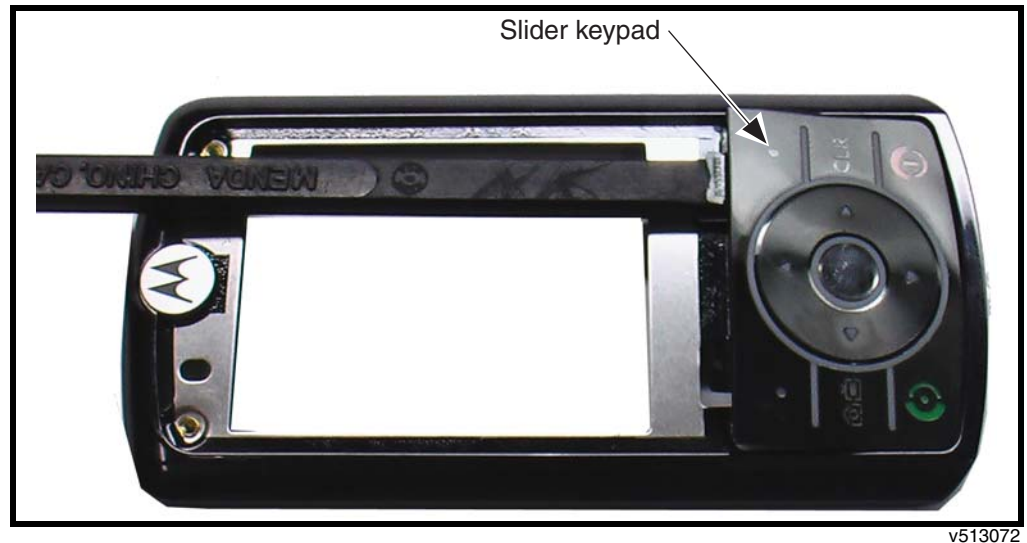

v513072

Figure 59. Removing the Slider Keypad

34. To replace, align the slider mechanism to the slider assembly and slide the mechanism onto the slider assembly.
35. Insert the slider arm bushing into the cutout in the slider assembly.
36. With the connector on the hydra-flex in the open position, insert the display flex fully into the ZIF connector. Close the ZIF connector to lock the flex.

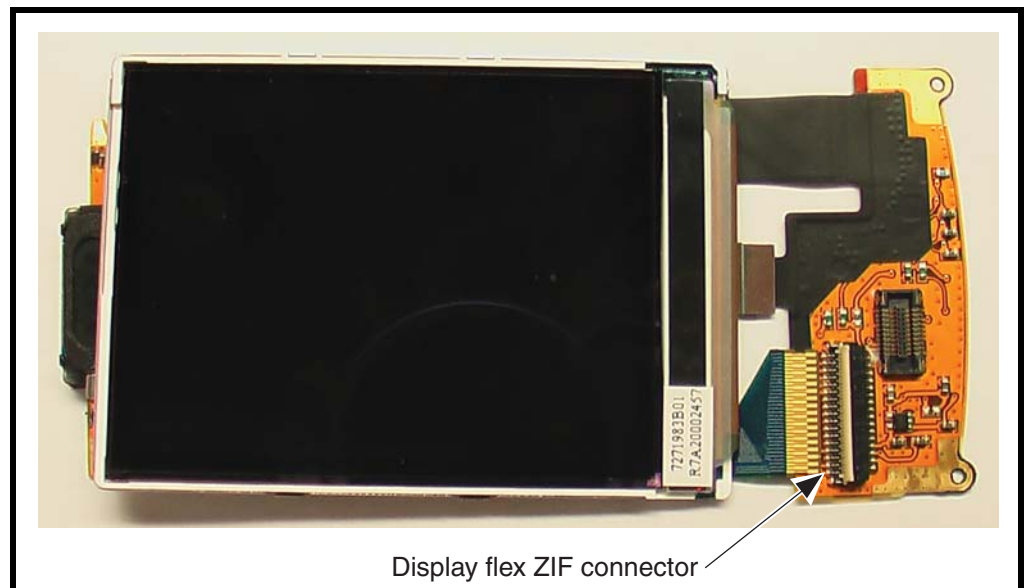

v513340

Figure 60. Inserting the Display Flex ZIF Connector

37. Place the display/hydrflex onto the slider assembly. Route the PCB connector flex through the magnesium opening and manually feed the entire flex so that the speaker lays on the speaker pocket on the top of the slider inner.

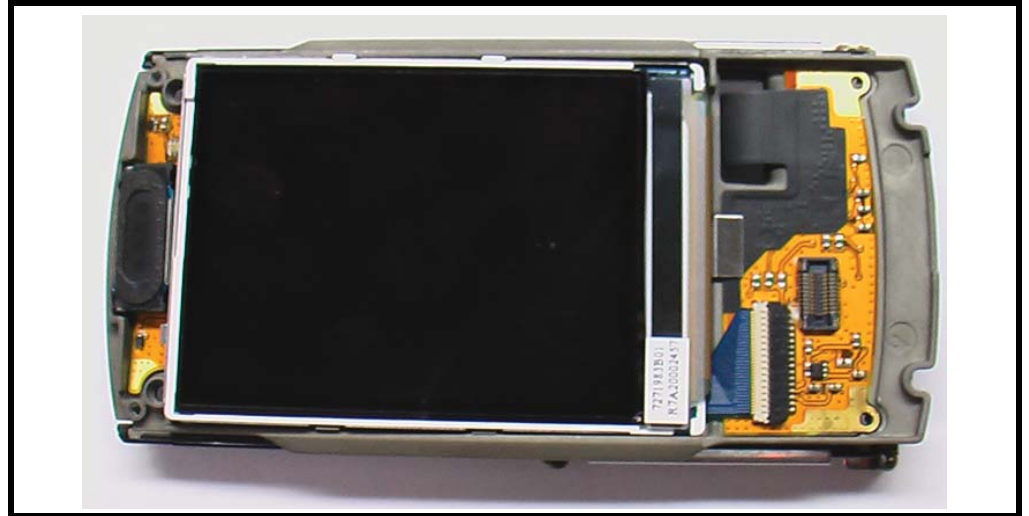

v513341

Figure 61. Installing the Hydrflex

38. Place the upper ground clip over the flex and screw holes on the magnesium inner. Secure the clip with the two thread forming screws. Use the T5 driver to tighten the screws to a torque setting of .7 in Lbs.

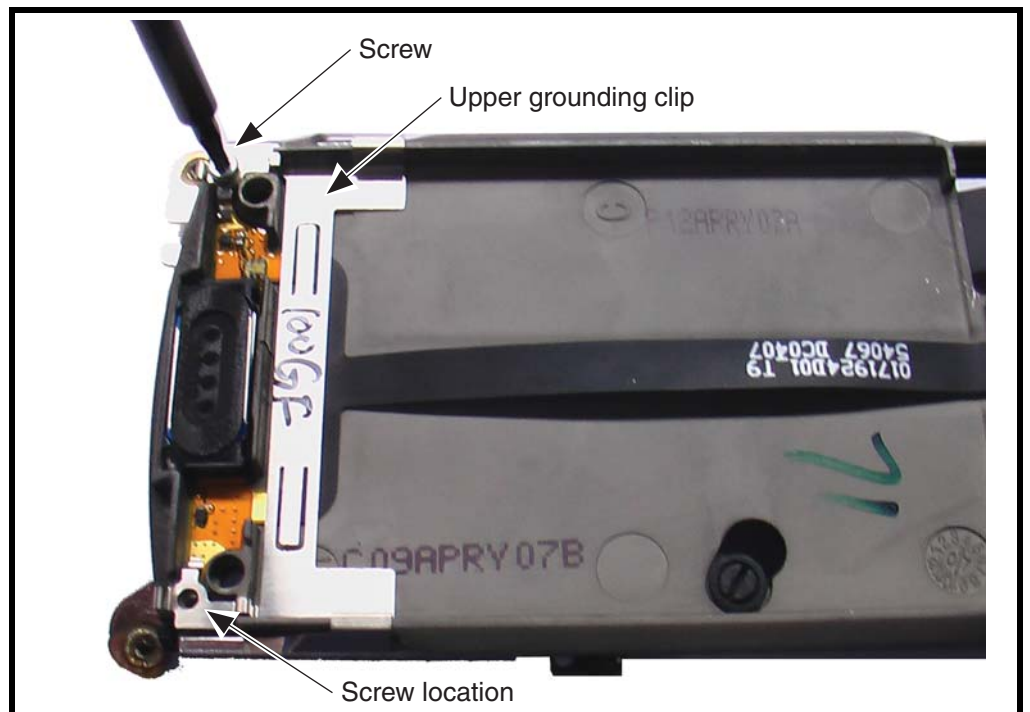

v463422

Figure 62. Installing the Upper Grounding Clip

39. Once the display is in the slider inner, press down on the bezel retaining features (red circles) to insure that the display is fully seated on the pad.

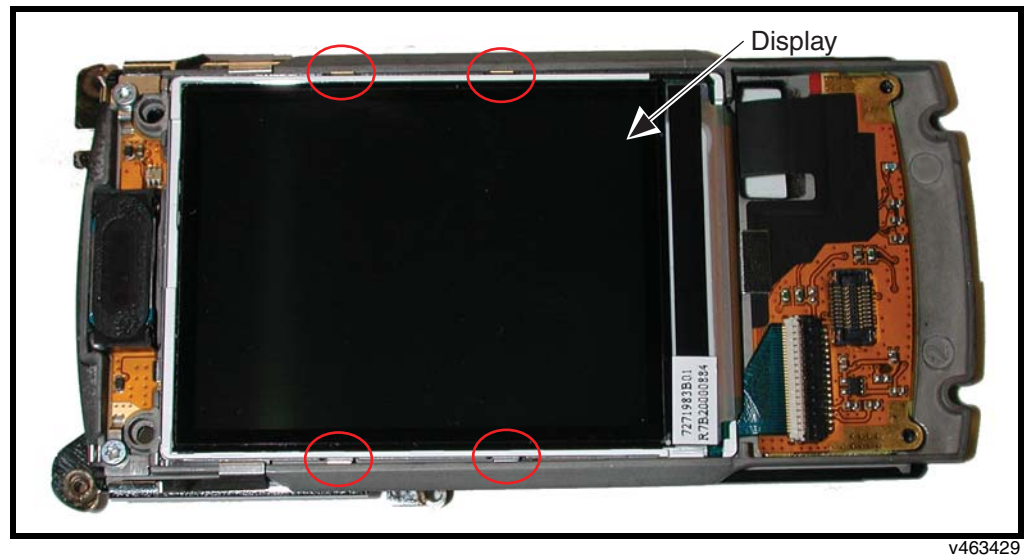

Figure 63. Installing and Seating the Display

40. Place the lower grounding clip onto the assembly over the lower part of the hydra-flex and insert two mag. forming screws over the ground clip and into the inner housing and secure with the T5 driver to .7 in Lbs.

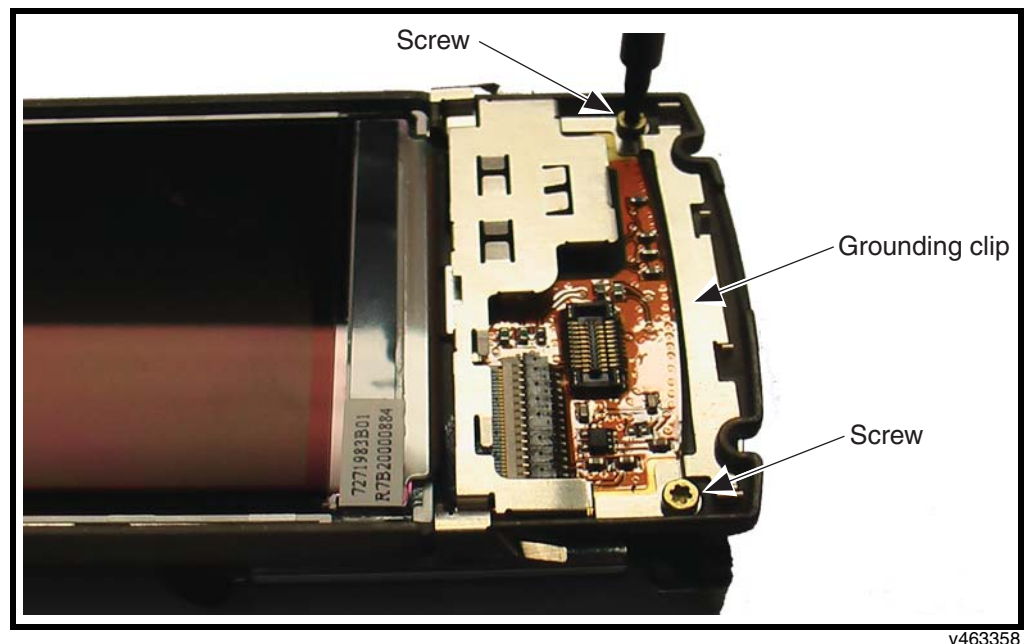
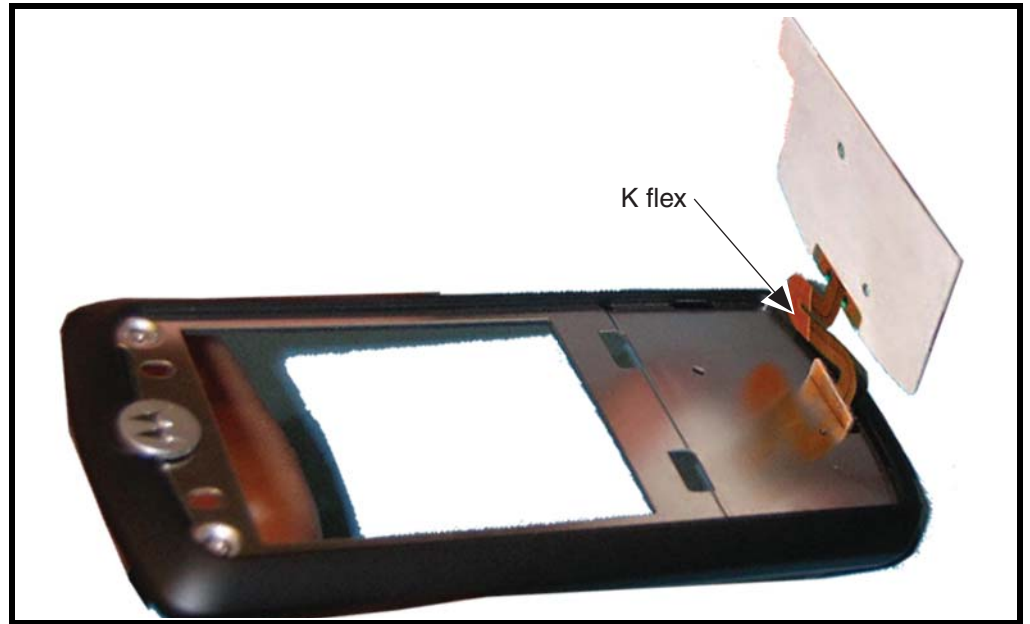

Figure 64. Installing the Lower Grounding Clip

41. Install the keypad flex by routing the it through the opening in the bottom of the slider outer.



v463430

Figure 65. Routing the K Flex

42. Remove the adhesive liner on the keypad flex and position it to the alignment holes in the housing.

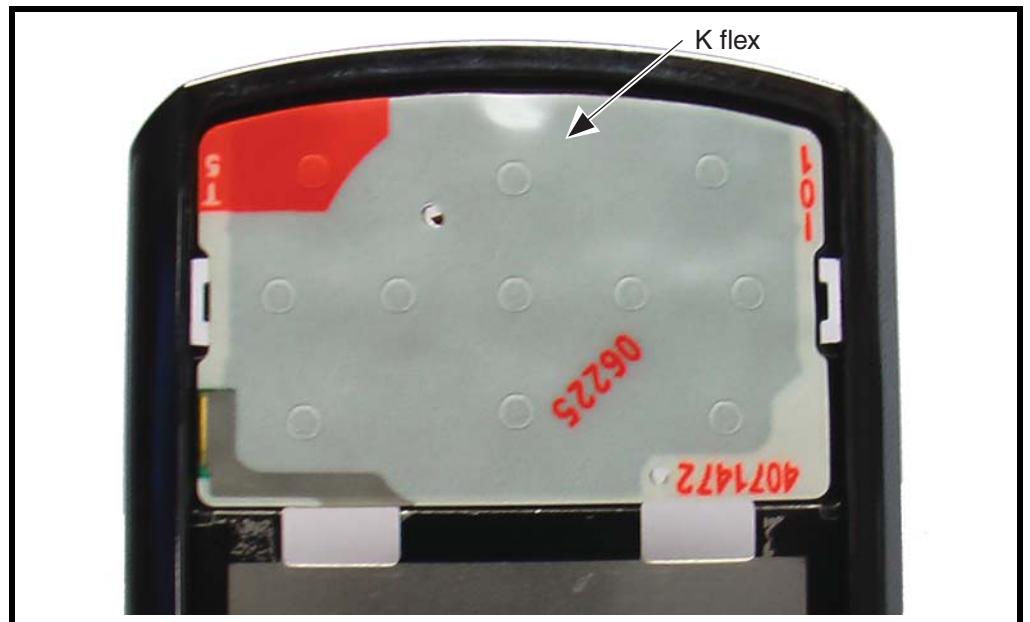

v463424

Figure 66. Installing the Keypad Flex

43. Place the slider outer over the fixture and insert the pins through the holes on the slider outer and press down on the outer so that it makes contact with the adhesive on the keypad flex.
44. Once the Keypad flex is applied to the slider outer, rub the air pockets out of the Mylar and actuator sheet. This will improve the placement of the keypad.
45. Inspect the flex on opposite side for damage during the assembly process.
46. Assemble the slider keypad as shown. First insert the bottom tabs into the housing slots then cam it over and insert the side tabs into the housing. Lay the keypad into the designated pocket on slider housing. The bending tabs should be inserted into the side slots. Be careful that the bending tabs do not damage the EL Panel during assembly.



Do not scratch the EL panel and the slider front housing with the metal keypad tabs.



v463431

Figure 67. Installing the Slider Keypad

47. Turn the slider outer with the inside of the housing facing up and keep it flat on the table surface, place the black stick behind the keypad tab and proceed to bend the tab towards the inside of the housing to form 30 degrees.

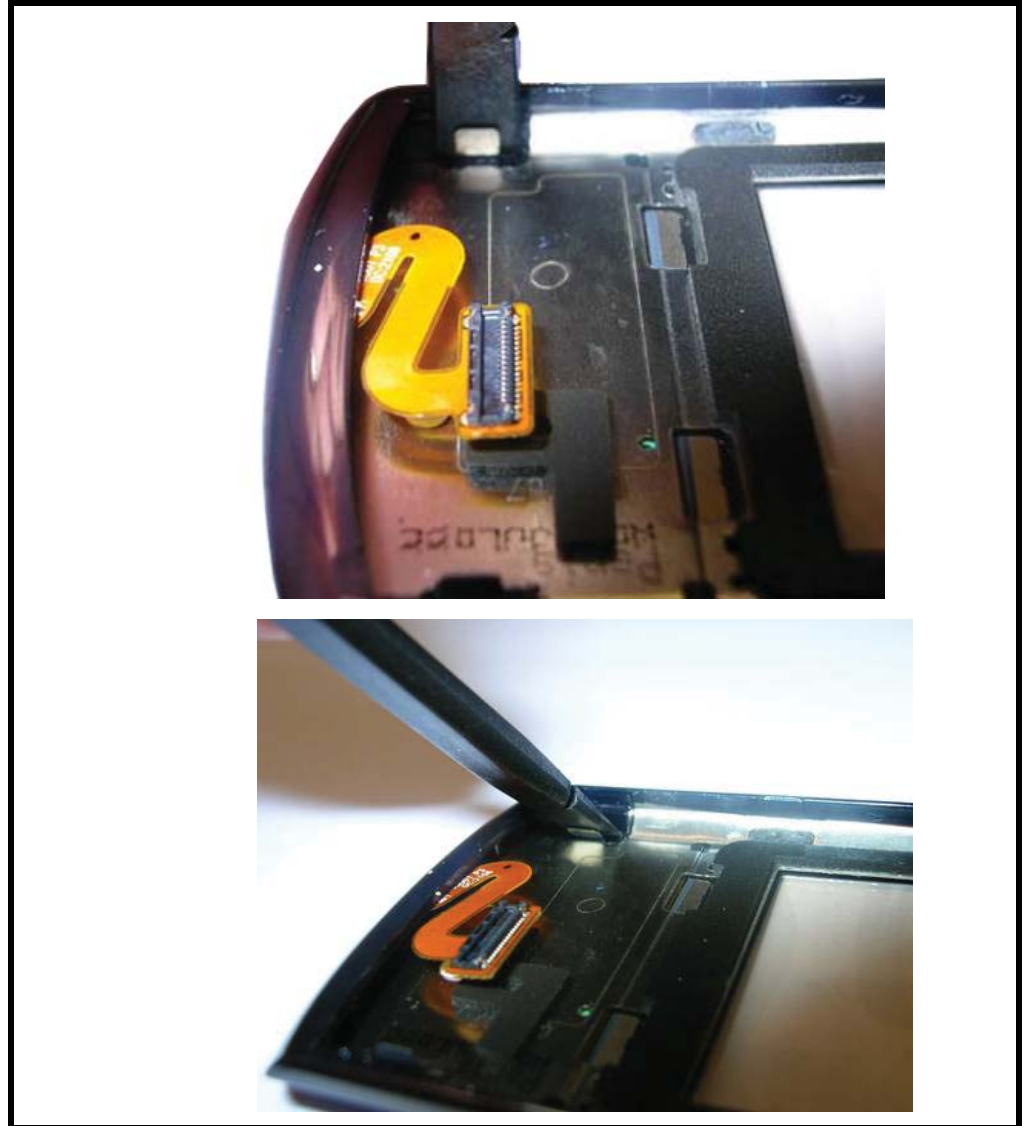
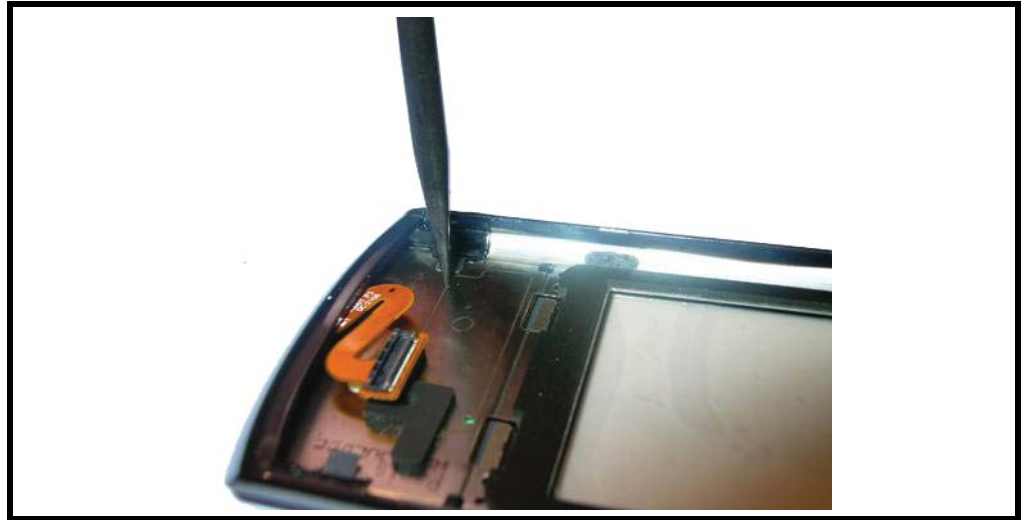

Figure 68. Bending the Slider Keypad Tabs

v526845

48. Once the initial bend has been established next directly press down on the tabs with the black stick.



v526846

Figure 69. Bending the Slider Keypad Tabs

49. Replace the Main lens (see page 61).

Attach the Slider to the Front housing

1. Before assembling slider please inspect the slider guide to insure that the slider mechanism pivot arm is properly inserted into the magnesium housing.
2. Keep the slider outer close to the magnesium inner part as shown.
3. Maintain a 70 degree angle between the 2 components.

4. Grab the keypad flex and connect it to the hydra-flex connector as shown.

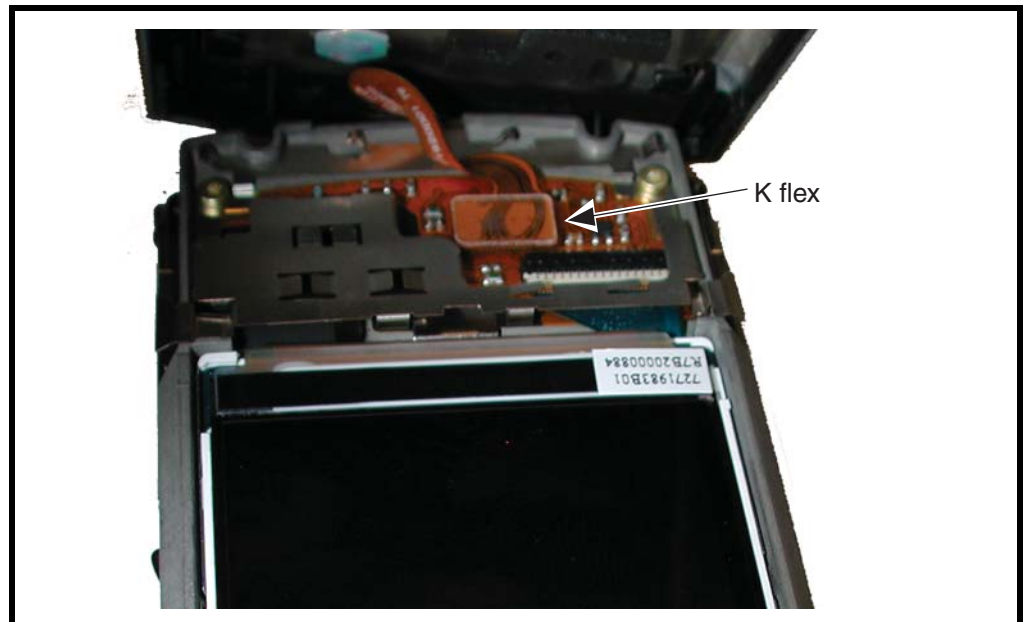

v463424

Figure 70. Connecting the Keypad Flex

5. Handle the flex very carefully to prevent damage.
6. The display liner must be removed prior to closing the slider outer and inner housing (Fig.2) use a light blast of ionized air to eliminate any foreign matter on the display and inside the display lens.
7. After the keypad flex connector is attached to the hydra-flex, relocate the slider guide to about half way at the slider then ski boot the inner housing into the slider outer and at the same time, close the angle between the two components. Make sure that the delrin rails are in the proper position.
8. Hold the slider assembly vertically and carefully slide the slider guide to the lower position be, extremely careful not to damage the transceiver flex that is hanging from the rear of the assembly.

9. Insert the black screws to the threaded inserts. Use a Torx Plus 5 IP driver set at .7 in lbs.

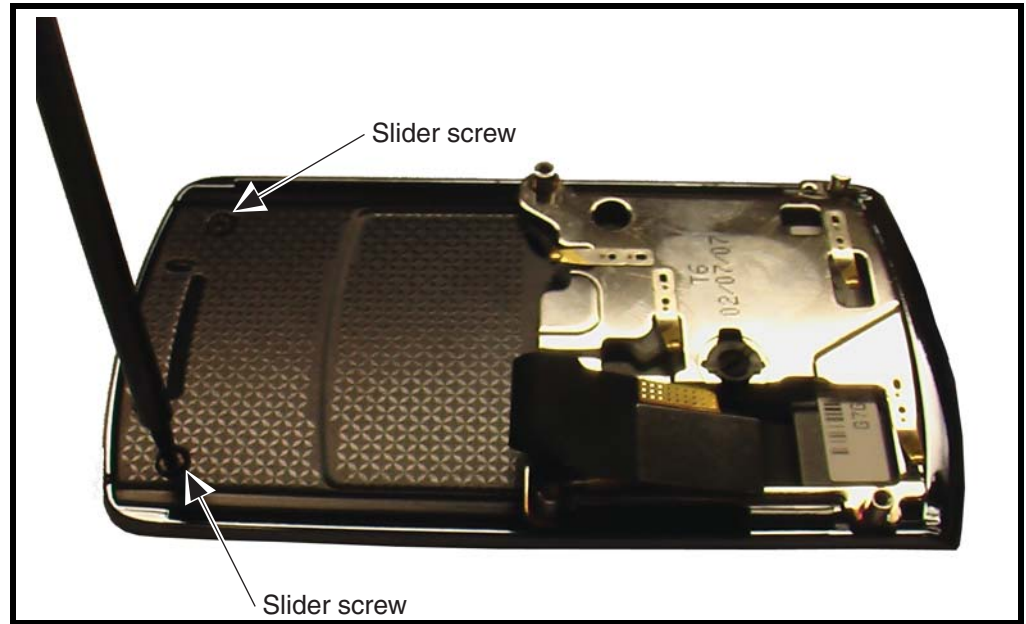

v463424

Figure 71. Inserting the Slider Screws

10. Verify position of the delrin rails in the assembly. Check for gaps. Make every effort to avoid damage the PCB flex. After assembly inspect the slider for smooth gliding motion. Also check for the correct placement of the slide inner bushing.

Removing and Replacing the Main Lens



It is mandatory that the following special tools be used when following this procedure:

Z6m/tv Lens Press Tool - part number 0-00-00-40879

1. Insert the disassembly tool into the gap between the lens and the slider outer housing and gently pry upward.

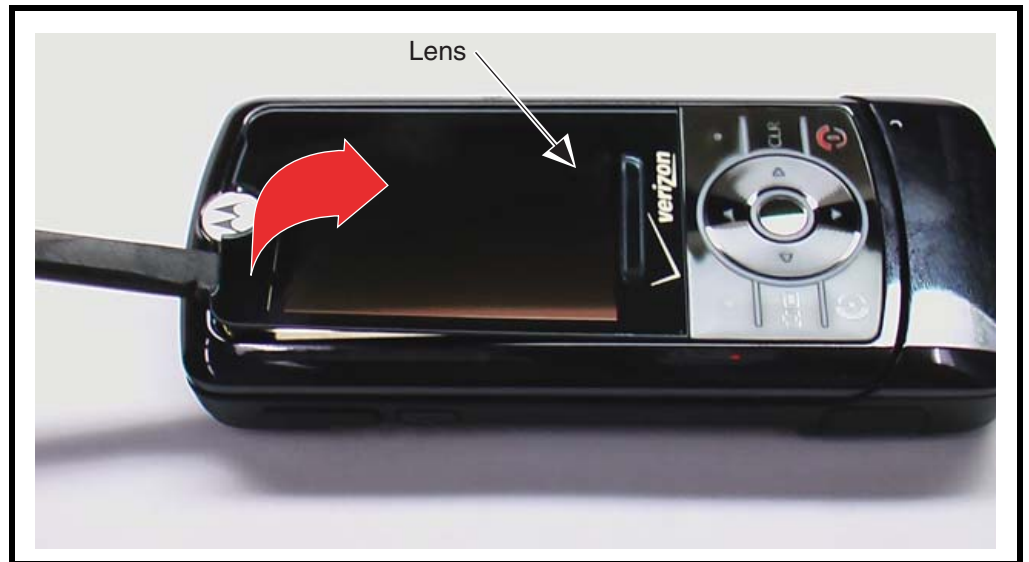

v503131

Figure 72. Removing the Display Lens

2. Remove any excess adhesive from the slider outer housing.
3. To replace, prepare the display lens for installation to the slider outer, bend the liner back in two areas to avoid interference when assembling.
4. Before placing the lens into the outer housing, move the medallion blue liner tab away from the lens resting area.
5. Lens is to be inserted at top of slider outer and dropped down (the bottom edge - closest to keypad should be inserted last) to ensure bonding.
6. Turn the slider outer with the inside of the housing facing up and keep it flat on the table surface. Bend the side keypad tabs to the inside by inserting the flat side of the disassembly tool flush behind the keypad tab
7. Bend the tab towards the inside of the housing to form a 30 degree angle. Repeat this step for the other side tab.
8. Once the initial bend has been established next directly press down on the tabs with the black stick. Repeat this step for the other tab.

9. Once the display lens is fully assembled, use the lens press fixture to properly adhere the lens to the outer slider. Press time is 10 seconds.

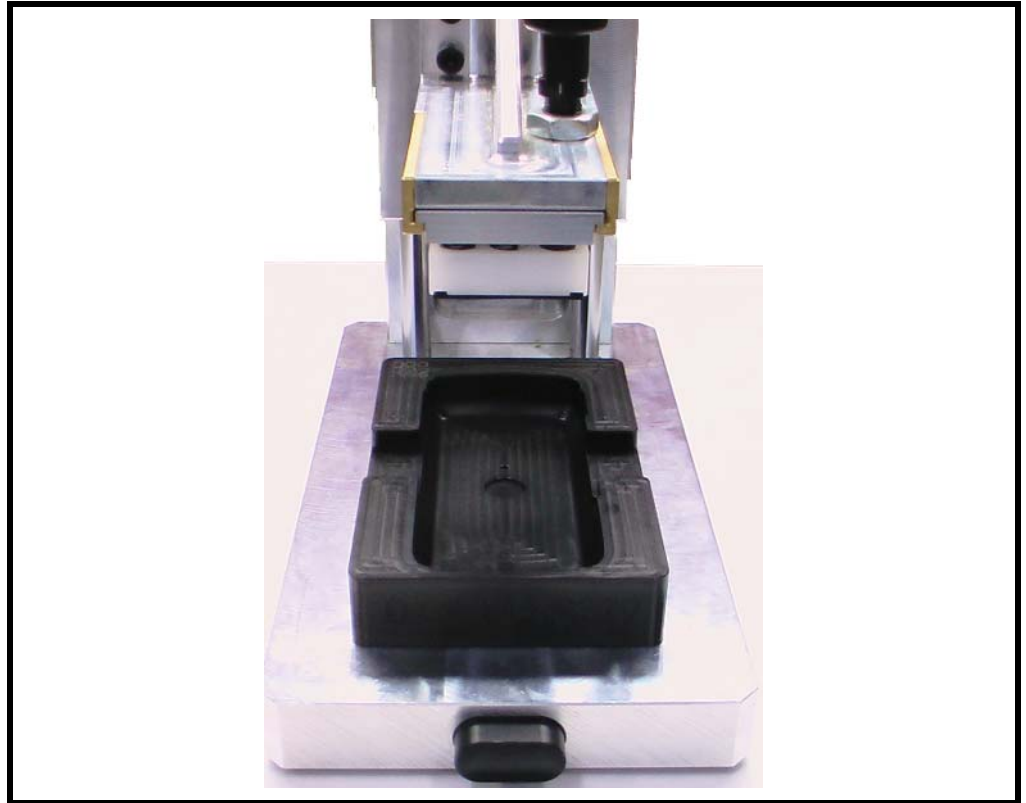

v513342

Figure 73. Z6m/Z6tv Lens Press Fixture

Removing and Replacing the Keypad Mylar

The keypad mylar should be replaced when repairs are performed on the PCB

It is mandatory that the following special tools be used when following this procedure:



Z6m/Z6tv EL Alignment- and Press Tool - part number 0-00-00-40878

Generic Press Fixture - part number 19501980 Available at the AMS Online-shop www.online-shop.ams-fl.com/ (for access please contact your local Motorola contact)

The Z6m/Z6tv EL alignment and press tool must be used for this replacement procedure.

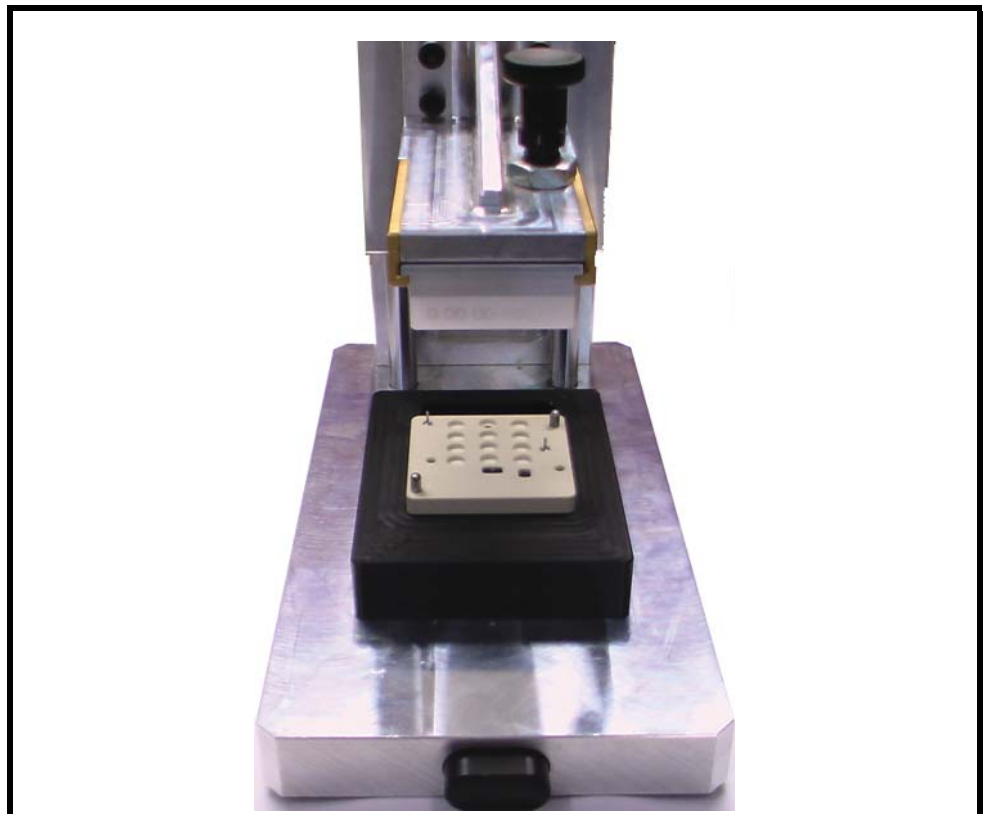

v513343

Figure 74. Z6m/Z6tv EL Alignment and Press Tool

1. Remove the keypad mylar with the plastic tweezers, as shown.

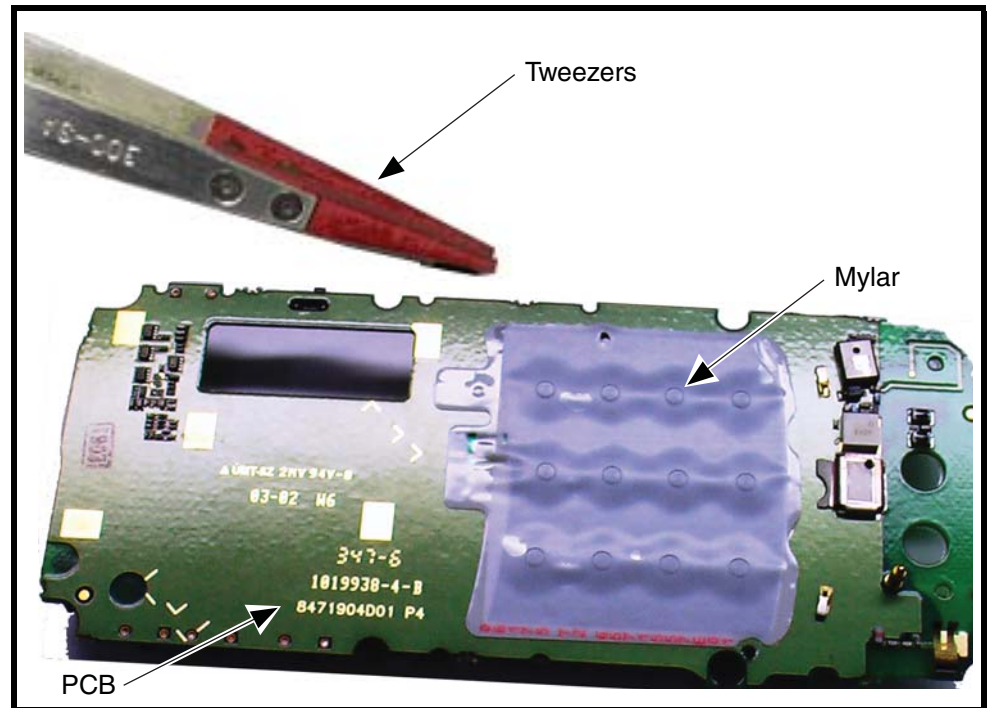

V483979

Figure 75. Removing the Keypad Mylar

2. To replace the keypad mylar, use the Z6m/Z6tv EL Alignment and Press tool.

3. Peel off the adhesive liner from the bottom side of the keypad mylar. Place the keypad into the fixture. Align the keypad using the fixture alignment pins.

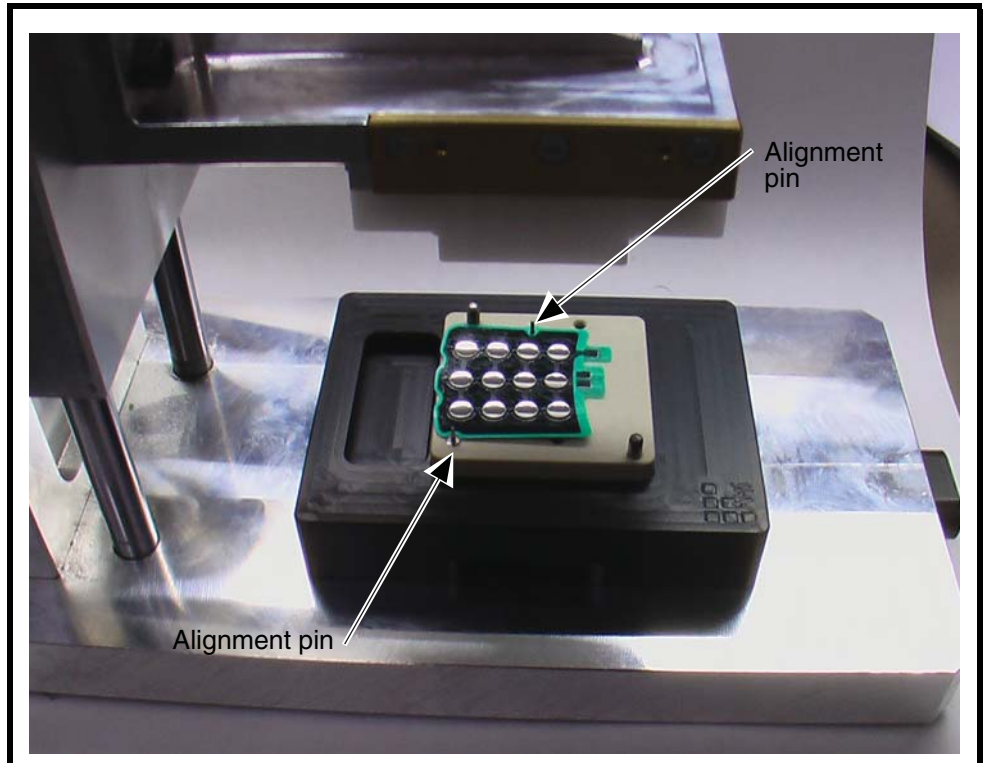
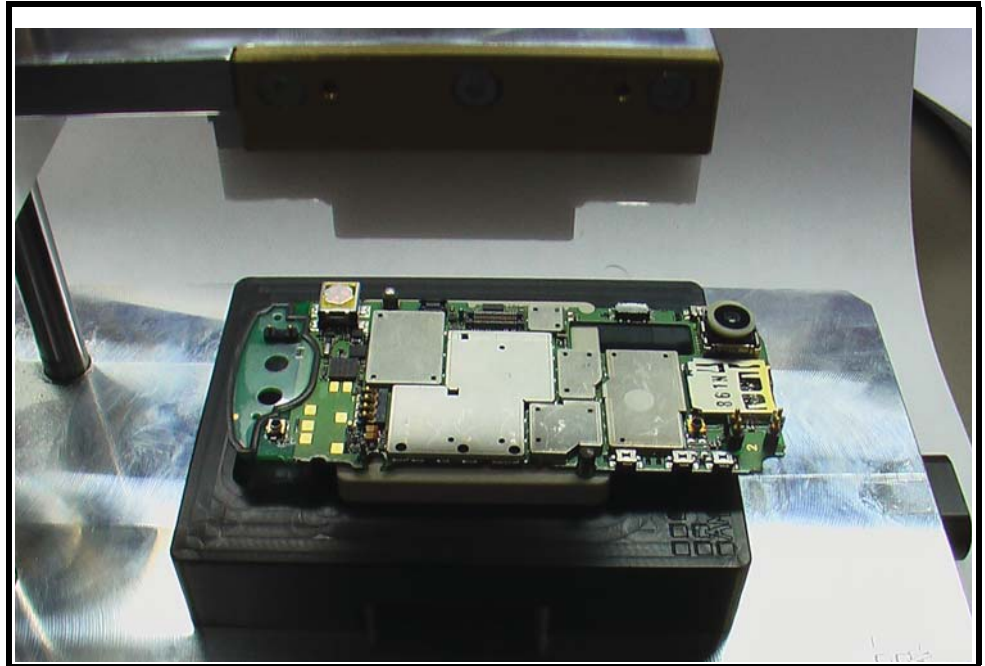

Figure 76. Keypad Mylar Alignment

v513344

4. Clean the mylar area on the main PCB, and then place it on top of the keypad mylar using the fixture alignment pins.



v513345

Figure 77. PCB Alignment

5. Close the fixture for 15 seconds.

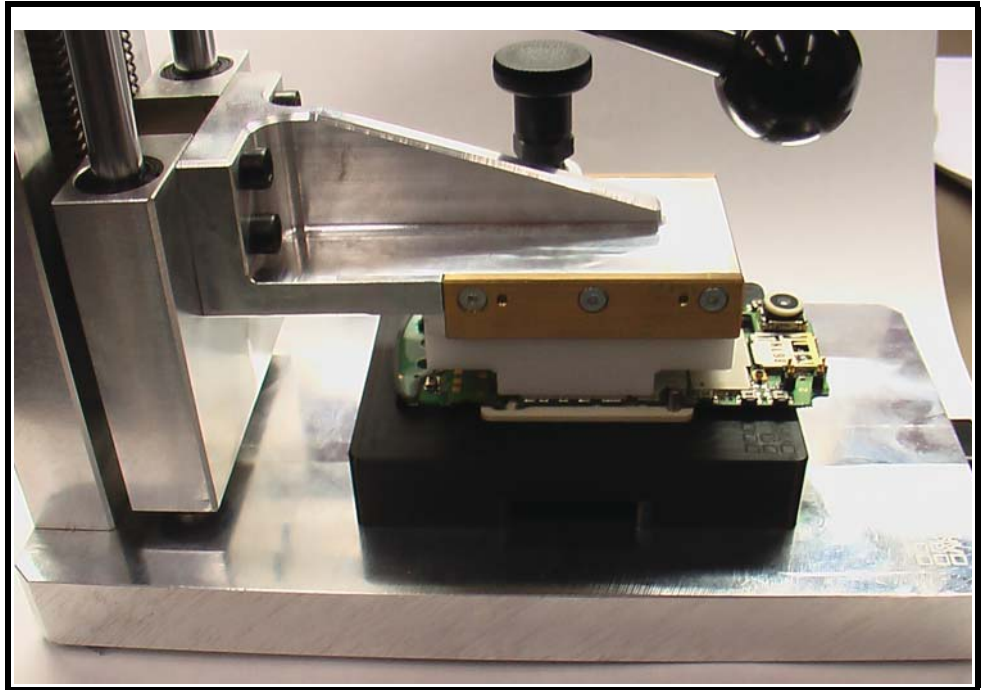

Figure 78. EI Mylar Press Fixture Closed

v513346

6. Open the fixture and check the assembly for correct positioning of the mylar on the PCB.

Slider Test Procedures

Perform the following slider test procedures after phone assembly has been completed.

Slider Stop Test

1. Hold the phone at a 45 degree angle with one hand as shown.

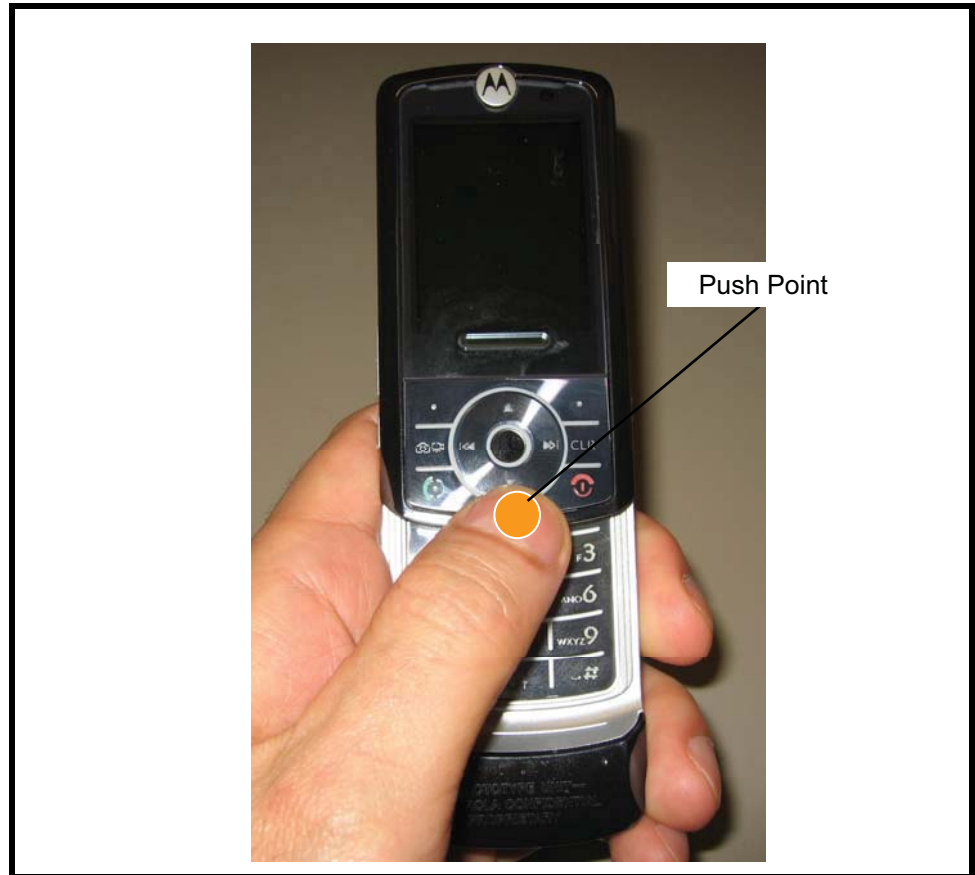

V483980

Figure 79. Slider Stop Test

2. Fully open the slider.
3. Place thumb over bottom edge of slider outer housing below the Nav Disk and press repeatedly.
4. If the repair technician questions the acceptability of the slider slop, then the technician must judge the phone by comparing it to a properly functioning unit.
5. If the slider slop is worse than a properly functioning unit, then the phone fails this test.
6. Any failed phone must be quarantined and reworked.

Short Travel Test (Slider Open)

1. Hold the phone at a 45 degree angle with one hand as shown.



V483981

Figure 80. Slider Stop Test

1. Fully close the slider.
2. Place thumb over top edge of push bar as shown. Slightly open the slider so that the bottom tip of the slider is 0.0 – 1.0mm above the recessed arc on the front housing.
3. Release the slider by quickly lifting thumb and letting push bar slide beneath it. To guarantee a clean release, lift thumb directly upward or in opposite direction of slider motion. Never allow thumb to move in the same direction as slider motion.
4. If the slider fails to reach its fully closed position within 2 seconds after release, the phone fails this test. The speed of the motion is irrelevant.
5. All failed phones must be quarantined and reworked.

Dead Zone Test

1. Hold the phone at a 45 degree angle with one hand as shown.

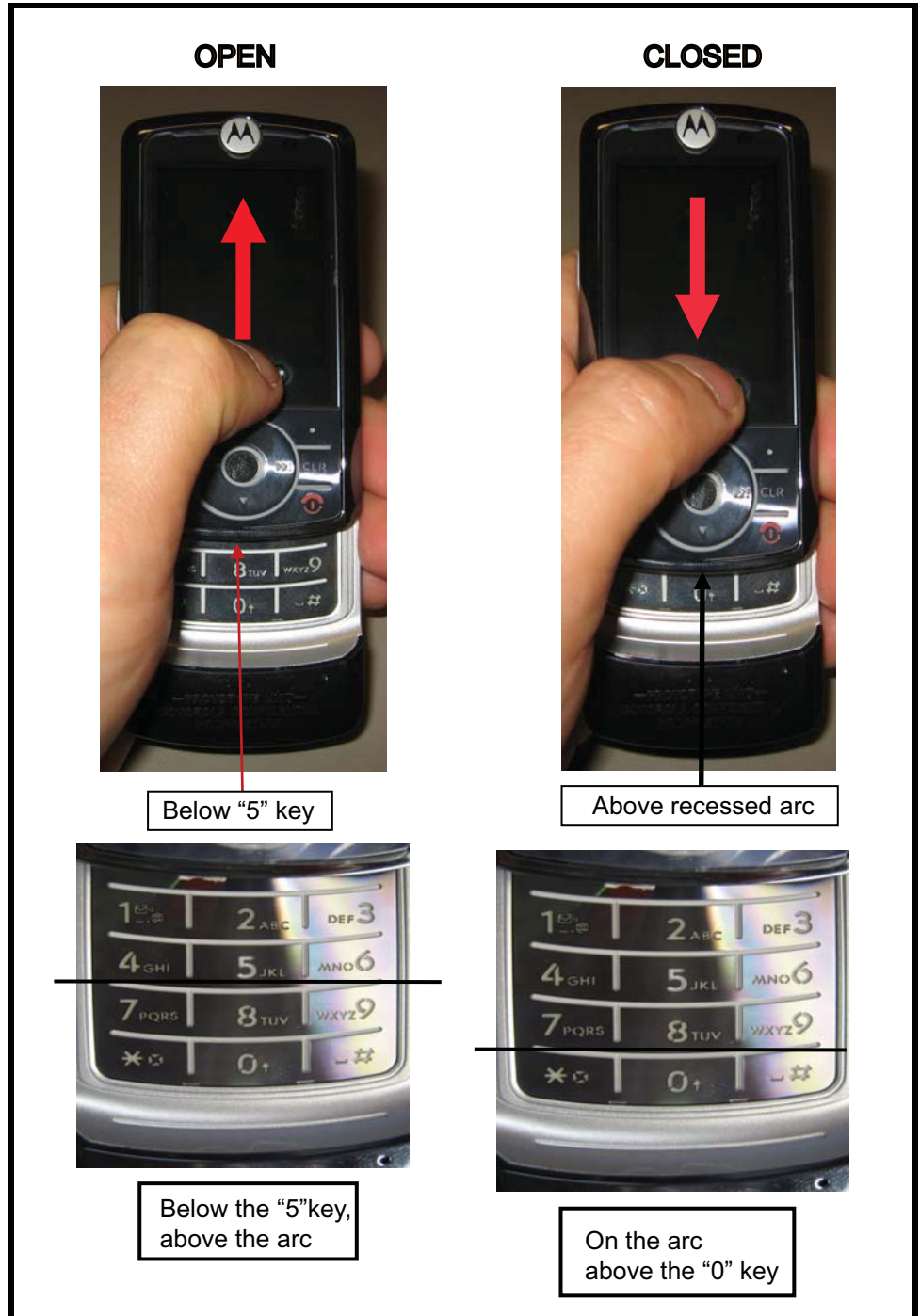

V483980

Figure 81. Dead Slider Test

2. Place thumb over top edge of push bar as shown. Open the slider so that the bottom tip of the slider is on the arc above the “0” key on the XCVR keypad.
3. Release the slider by quickly lifting thumb and letting push bar slide beneath it. To guarantee a clean release, lift thumb directly upward or in opposite direction of slider motion. Never allow thumb to move in the same direction as slider motion.
4. If the slider fails to reach its fully closed position within 2 seconds after release, the phone fails this test. The speed of the motion is irrelevant.
5. Place thumb over top edge of push bar as shown. Open the slider so that the bottom tip of the slider is below the “5” key but above the arc on the XCVR keypad.
6. Release the slider by quickly lifting thumb and letting push bar slide beneath it. To guarantee a clean release, lift thumb directly upward or in opposite direction of slider motion. Never allow thumb to move in the same direction as slider motion.
7. If the slider fails to reach its fully open position within 2 seconds after release, the phone fails this test. The speed of the motion is irrelevant.
8. All failed phones must be quarantined and reworked.

Smoothness Test

1. Hold the phone at a 45 degree angle with one hand.
2. Place thumb over top edge of push bar and fully open and close the slider minimum of 2 times, line operator’s fingers must be in contact with push bar at all times during sliding.
3. If the line operator feels the sliding is bad, the phone fails this test.
4. Examples of things that qualify for bad slider are:
 - Rattling sound
 - Clicking noise
 - Tight sliding
 - Scratch sound
 - sluggish movement
 - Bumpy movement
5. All failed phones must be quarantined and reworked.

Phone Identification

Personality Transfer

A personality transfer is required when a phone is express exchanged or when the main board is replaced. Personality transfers reproduce the customer's original personalized details, such as menu and stored memory, such as phone books, or even just program a unit with basic user information such as language selection. Z6m/Z6tv telephones use Mobile Phone Tools software to effect a personality transfer.

Identification

Each Motorola CDMA phone is labeled with a variety of identifying numbers. Figures 82 and 83 describe the current identifying labels.

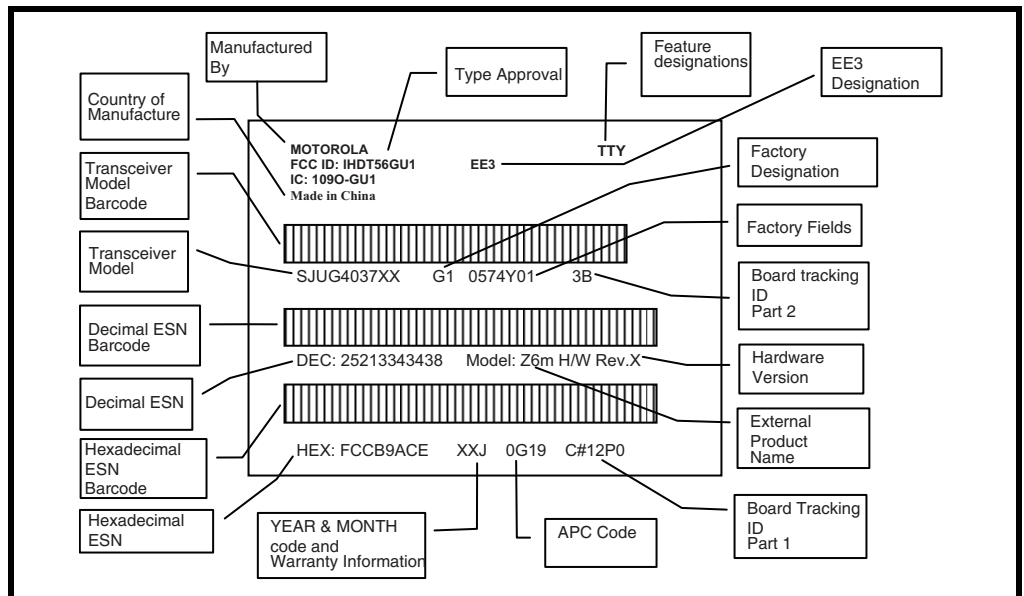

V510544

Figure 82. CDMA Telephone Identification Label

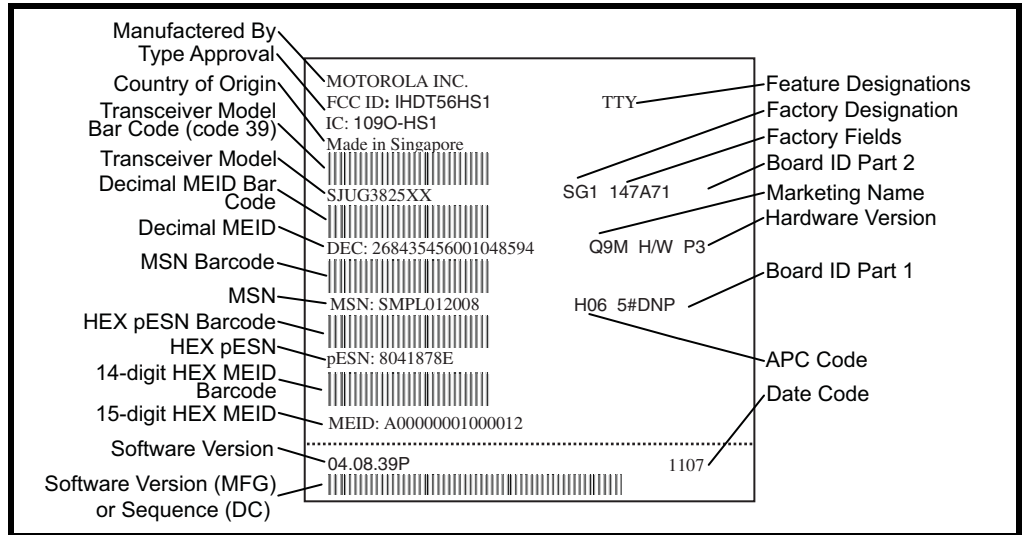

Figure 83. CDMA MEID Telephone Identification Label

020463o

Troubleshooting

Troubleshooting Chart

Table 3. Level 1 and 2 Troubleshooting Chart

SYMPTOM	PROBABLE CAUSE	VERIFICATION AND REMEDY
1. Telephone will not turn on or stay on.	a) Battery either discharged or defective.	Measure battery voltage across a 50 ohm (>1 Watt) load. If the battery voltage is <3.25 Vdc, recharge the battery using the appropriate battery charger. If the battery will not recharge, replace the battery. If battery is not at fault, proceed to b.
	b) Battery connectors open or misaligned.	Visually inspect the battery connectors on both the battery and the telephone. Realign and, if necessary, either replace the battery or refer to a Level 3 Service Center for the battery connector replacement. If battery connectors are not at fault, proceed to c.
	c) Transceiver board assembly defective.	Refer service to authorized Level 3 service center for replacement.
2. Telephone exhibits poor reception or erratic operation, such as calls frequently dropping or weak or distorted audio.	a) Antenna assembly defective.	Check to make sure that the antenna pin is properly connected to the transceiver board assembly. If connected properly, substitute a known good antenna. If the fault is still present, proceed to b.
	b) Transceiver board assembly defective.	Refer service to authorized Level 3 service center for replacement.
3. Display is erratic, or provides partial or no display.	a) Transceiver board connections faulty.	Remove rear chassis assembly from unit, check general condition of flexible printed cable (flex). If the flex is good, check that the flex connector is fully pressed down. If not, check connector to transceiver board connections. If faulty connector, replace the transceiver board assembly. If connector is not at fault, proceed to b.
	b) Slider assembly defective.	Temporarily replace the slider assembly with a known good assembly. If fault has been cleared, reassemble with the new flip assembly. If fault not cleared, proceed to c.
	c) Transceiver board assembly defective.	Refer service to authorized Level 3 service center for replacement.
4. Incoming call alert transducer audio distorted or volume is too low.	a) Faulty alert transducer	Replace with a known good alert transducer. Verify that the fault has been cleared and reassemble the unit with the new alert transducer. If fault not cleared, proceed to b.
	b) Faulty transceiver board assembly.	Refer service to authorized Level 3 service center for replacement.
5. Telephone transmit audio is weak. (usually indicated by called parties complaining of difficulty in hearing voice).	a) Transceiver board assembly defective.	Refer service to authorized Level 3 service center for replacement.

Table 3. Level 1 and 2 Troubleshooting Chart (Continued)

SYMPTOM	PROBABLE CAUSE	VERIFICATION AND REMEDY
6. Receive audio from earpiece speaker is weak or distorted.	a) Connections to or from transceiver board assembly defective.	Gain access to the transceiver board assembly as described in the procedures. Check flex and the flex connector from the slider assembly to the transceiver board assembly. If flex is at fault, replace slider assembly. If flex connector is at fault, proceed to d. If connection is not at fault, proceed to b.
	b) Slider assembly defective.	Temporarily replace the slider assembly with a known good assembly. If fault has been cleared, reassemble with the new slider assembly. If fault not cleared, proceed to c.
	c) Antenna assembly defective.	Check to make sure the antenna is installed correctly. If the antenna is installed correctly, substitute a known good antenna assembly. If this does not clear the fault, reinstall the original antenna assembly and proceed to d.
	d) Transceiver board assembly defective.	Refer service to authorized Level 3 service center for replacement.
7. Phone does not sense when slider is opened or closed (usually indicated by inability to answer incoming calls by opening the flip, or inability to make outgoing calls).	a) Transceiver board assembly defective.	Refer service to authorized Level 3 service center for replacement.
8. Internal Charger not working.	Faulty charger circuit on transceiver board assembly.	Refer service to authorized Level 3 service center for replacement.

Programming: Software Upgrade and Flexing

Contact your local technical support engineer for information about equipment and procedures for flashing and flexing.

Part Numbers

The following information is provided as a reference for the parts associated with Z6m/Z6tv telephones.

Exploded View Diagram

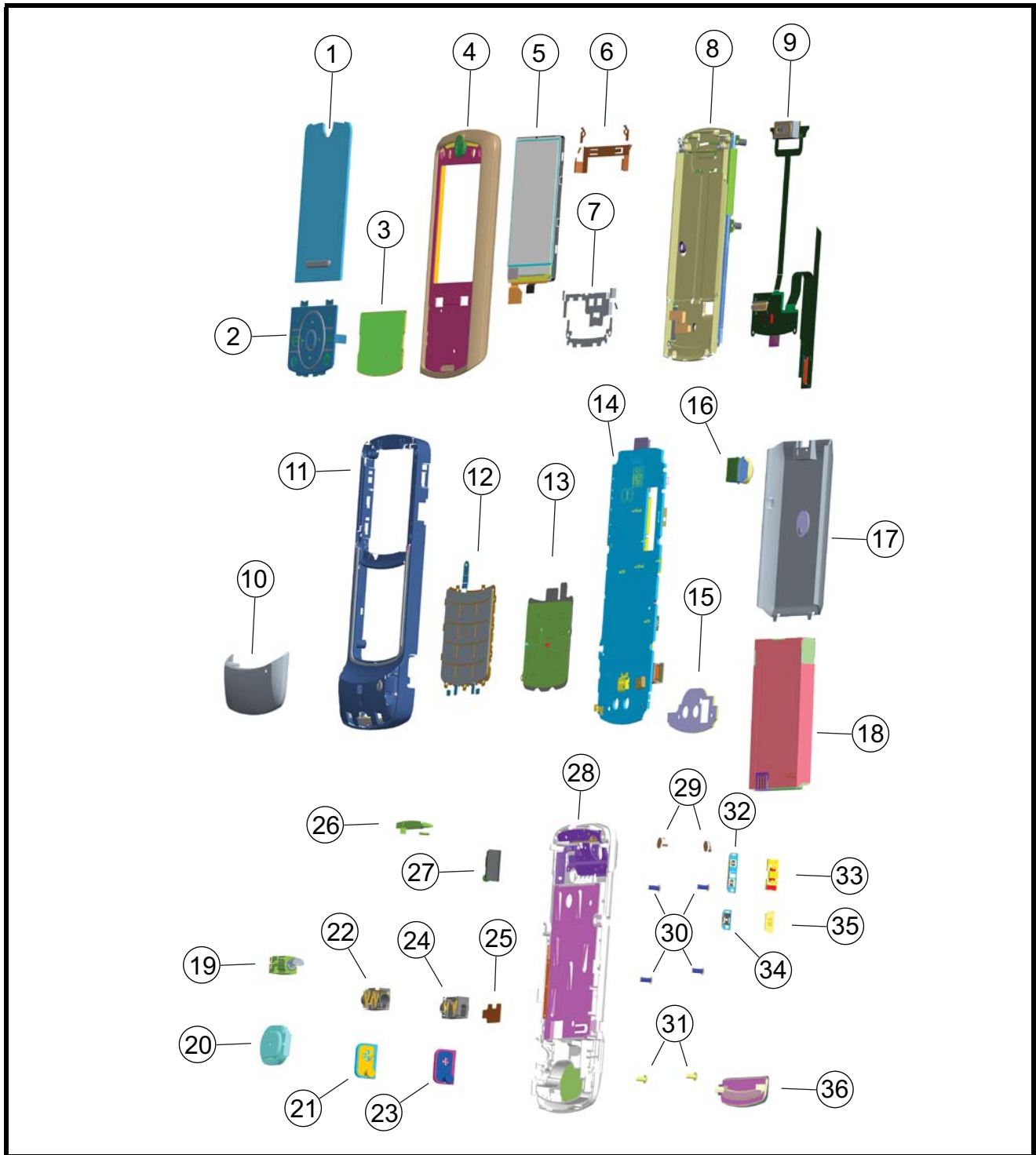

061699c

Figure 84. Exploded View Diagram (Sheet 1)

Parts List

Part numbers are provided only as a reference. Contact your local Motorola parts organization for current part number information.

Table 4. Parts List

Item #	Motorola Part Number	Description	Z6m SJUG3039AA	
			Z6tv SJUG2658AA	
1	6171270E02	LENS ASSEMBLY,CHEMICAL TOUGHENED GLASS, MAIN,BLACK SLATE NCVN BLACK,VERIZON	X	
1	6171270E04	LENS ASSEMBLY,CHEMICAL TOUGHENED GLASS, MAIN LENS, BLACK SLATE NCVN DARK PEARL GRAY, ROW		X
2	0171920D01	FLEX,KEYPAD,ASSEMBLY,SLIDE,	X	X
3	3871199F07	KEYPAD,SLIDER,DARK PEARL GREY,ROW 1		X
3	3871199F11	KEYPAD,SLIDER,BLACK SLATE,VZW	X	
4	0171121E05	ASSEMBLY,HOUSING,SLIDER,BLACK SLATE, OUTER,TNCVM	X	
4	0171121E06	ASSEMBLY,HOUSING,SLIDER,DARK PEARL GREY,OUTER,TNCVM		X
5	7271983B01	DISPLAY,LCD,PANEL MOUNT,2.275V,RECTANGULAR,2.0IN,262K TFT TM,240X320,PLATFORM,MODULE,SMART	X	X
6	4271267E01	CLIP,GROUNDING,BERYLLIUM COPPER, TOP SIDE	X	X
7	4271268E01	CLIP,GROUNDING,BERYLLIUM COPPER,BOTTOM SIDE	X	X
8	0171919D01	ASSEMBLY,HOUSING,SLIDER,LICORICE,INNER	X	X
9	0171924D01	PCB,FLEX,ASSEMBLY,HYDRA	X	X
10	1571948D07	HOUSING,COVER,PLASTIC - POLYCARBONATE,BLACK SLATE,UPPER ANTENNA CAP	X	
10	1571948D08	HOUSING,COVER,PLASTIC - POLYCARBONATE,DARK PEARL GREY,ANTENNA CAP,NCVM		X
11	0171921D03	ASSEMBLY,HOUSING,FRONT,LUSTROUS SILVER		X
11	0171921D05	ASSEMBLY,HOUSING,FRONT,BLACK SLATE	X	
12	3871699F01	KEYPAD,XCVR,BLACK SLATE, VZW	X	
12	3871699F02	KEYPAD,XCVR, LIGHT SILVER, ROW		X
13	4071134E01	XCVR, EL WITH DOMES	X	X
14	SLG5110AA-	ASSEMBLY,PRINTED CIRCUIT BOARD,TRANSCEIVER,CDMA,,EVDO,MEF	X	
14	SLG5245AA-	ASSEMBLY,PRINTED CIRCUIT BOARD,TRANSCEIVER,CDMA, EVDO ROW		X
15	3271296F01	BACK GASKET, POLY-SPEAKER,	X	X
16	0171973D03	CAMERA,ASSEMBLY,IMAGER GREY LENS AND RETENTION RING	X	X
17	SNN5813A	ASSEMBLY,BATTERY,LITHIUM ION,BT50,910MAH	X	X
18	SHN0596A	ASSEMBLY,COVER,BATTERY DOOR,DARK PEARL GREY,PF4 ALLTEL		X
18	SHN0459A	ASSEMBLY,COVER,BATTERY DOOR, PF4 DARK PEARL GREY ROW		X
18	SHN0455A	ASSEMBLY,COVER,BATTERY DOOR,BLACK,PF4 SLATE VZW	X	
19	0171140E01	ALERT DEVICE,VIBRATOR,CYLINDRICAL,	X	X
20	5071508D03	LOUDSPEAKER,DYNAMIC,600-7000,8OHM, .5W,CONTACT,3X14X20	X	X
21	0571131F03	GROMMET,URETHANE FOAM,HEADSET JACK, LUSTROUS SILVER		X
22	0971177D01	CONNECTOR AUDIO,JACK,5CONT,GOLD,3.5MM 4-POLE		X
23	0571646F01	GROMMET,PLASTIC-POLYCARBONATE,HEADSET JACK, 2.5MM, LICORICE	X	

Table 4. Parts List (Continued)

		Z6m SJUG3039AA		
		Z6tv SJUG2658AA		
Item #	Motorola Part Number	Description		
24	0971499F01	CONNECTOR,JACK,HEADSET JACK, 2.5MM	X	
25	1171643E01	TAPE,ADHESIVE,.022FTL,.5579INW,.002INTHK,HEAD SET JACK	X	X
26	0571976D03	GROMMET,PLASTIC,MICROSD, LUSTROUS SILVER		X
26	0571976D02	GROMMET,PLASTIC,MICROSD,LICORICE	X	
27	0571247F02	GROMMET,RUBBER,EMU,LUSTROUS SILVER		X
27	0571247F01	GROMMET,RUBBER,EMU,LICORICE	X	
28	0171922D12	ASSEMBLY,HOUSING,REAR,BLACK SLATE,SOFT TOUCH	X	
28	0171922D13	ASSEMBLY,HOUSING,REAR,DARK PEARL GREY		X
29	0571300E03	GROMMET,RUBBER,SCREW,DARK PEARL GREY		X
29	0571300E05	GROMMET,RUBBER,SCREW,BLACK SLATE	X	
30	0371064E03	SCREW,MACHINE,M1.4X.3,4.5MM,STAR,PAN,STEEL,2.7 HEAD DIAMETER	X	X
30	0371064E05	SCREW,MACHINE,M1.4X.3,2.8MM,STAR,PAN,STEEL,SLIDE	X	X
31	0387791L07	SCREW,SELF-TAPPING,K15X.67,4.25MM,STAR,BUTTON,STEEL,THREAD FORMING	X	
31	0387791L11	SCREW,THREAD ROLLING,K15X.67,4.25MM,STAR,BUTTON,STEEL,TORX PLUS,4.25MM,THREAD FORMING		X
32	3871969D03	BUTTON,SIDE,PLASTIC - POLYCARBONATE,VOLUME,BLACK SLATE	X	
32	3871969D05	BUTTON,VOLUME,PLASTIC - POLYCARBONATE,SIDE, LUSTROUS SILVER		X
32	3871970D03	BUTTON,VIDEO RECORDER,PLASTIC - POLYCARBONATE,VIDEO RECORDER,BLACK SLATE	X	
32	3871970D05	BUTTON,VIDEO RECORDER,PLASTIC - POLYCARBONATE,SIDE, LUSTROUS SILVER		X
33	3871972D03	BUTTON,SIDE,PLASTIC - POLYCARBONATE,HOLD,BLACK SLATE	X	
33	3871972D05	BUTTON,SIDE,PLASTIC - POLYCARBONATE,HOLD,LUSTROUS SILVER		X
34	3871968D03	BUTTON,SIDE,PLASTIC - POLYCARBONATE,SPEAKER PHONE,BLACK SLATE	X	
34	3871968D05	BUTTON,SIDE,PLASTIC - POLYCARBONATE,SPEAKER PHONE,LUSTROUS SILVER		X
36	0171893D04	HOUSING ASSEMBLY,SPEAKER MICROPHONE,CAP DARK PEARL GREY		X
36	0171893D05	HOUSING,SPEAKER MICROPHONE,SPEAKER CAP ASSEMBLY,LICORICE,15 GLOSS	X	
N/A	0371235E01	SCREW,M1.2X.5,1.75MM,STAR,PAN,STEEL,THREAD-FORMING, MAG FORMING	X	X
N/A	0371235E05	SCREW,M1.2X.5,2MM,STAR,PAN,STEEL,MAG FORMING	X	X

To order parts you may use the following link:

https://wissc.motorola.com/wissc_root/main/BrowserOK.html

(Password is Required)

For information on ordering parts please contact the appropriate “Replacement Parts Service Division (RPSD)” on page 7.



There is a danger of explosion if the Lithium Ion battery pack is replaced incorrectly. Replace only with the same type of battery or equivalent as recommended by the battery manufacturer. Dispose of used batteries according to the manufacturer's instructions.

INDEX

A

airplane mode indicator 14
alert settings 14

B

battery
 function 14
 gauge 14
 level indicator 13
 removing 16
battery housing
 removing 16
Bluetooth
 connection indicator 14

C

Canadian Interference-Causing Equipment regulations 4
changes
 product 4
conventions 6
copyrights
 computer software 5

D

data call
 indicator tethered indicator 13
disassembly 16
display 12

E

embedded WAP/BREW indicator 13
exploded view diagram 76
exploded view parts list 77

F

FCC rules 4
features
 voice recognition 10
features, product 9

H

home screen 12

I

identification 72
 product 4
indicators
 airplane mode 14
 battery level 13
 Bluetooth connection 14
 data call/tethered/embedded WAP/BREW 13
 location on 13
 message 14
 no service 13
 sound on & vibrate on 13
 sounds off (silent) 13
Introduction 4

K

keypad, removing and replacing 28

L

location on indicator 13

M

memory card
 removing 18
menu
 structure diagram 14
message indicator 14

N

names
 product 4
no service indicator 13

O

operation, general 11
overview, product 9

P

parts 75
 exploded view diagram 76
 exploded view parts list 77
product
 changes 4
 identification 4
 names 4

R

- rear housing
 - removing 19
- Rear Housing Components, removing and replacing 30
- regulatory agency compliance 4
- removing
 - battery 14, 16
 - battery housing 16
 - keypad 28
 - memory card 18
 - rear housing 19
 - Rear Housing Components 30
 - Slider assembly 38
 - transceiver board assembly 24
- replacement parts
 - contact information 6
- replacing
 - battery 16
 - keypad 28
 - rear housing 19
 - Rear Housing Components 30
 - Slider assembly 38
 - transceiver board assembly 24

S

- service manual
 - about 5
 - revisions 6
 - scope 5
- service policy 6
 - customer support 6
 - out of box failure 6
 - product support 6
- service procedure
 - ordering replacement parts 6
- shut down
 - upon battery removal 14
- SIM card
 - personality transfer 72
- Slider assembly, removing and replacing 38
- sound on & vibrate on indicator 13
- sounds off (silent) indicator 13
- specifications 8
- support
 - customer 6
 - product 6

T

- tools and test equipment 15

- transceiver board assembly, removing and replacing 24
- troubleshooting 74

U

- user interface diagrams 14

V

- voice recognition 10

W

- warranty service 6



MOTOROLA