



MOTOROLA

Level 1 and 2 Service Manual

6809497A15-O

V3x **Digital Wireless Telephone**



UMTS 2100, GSM 900/1800/1900 GPRS

Introduction	5
Product Identification	5
Product Names	5
Product Changes	5
Regulatory Agency Compliance	5
Computer Program Copyrights	6
About This Service Manual	6
Warranty Service Policy	7
Parts Replacement	8
Product Overview	11
Features	11
General Operation	14
Controls, Indicators, and Input / Output (I/O) Connections	14
Alert Settings	15
Battery Function	15
Operation	16
Tools and Test Equipment	17
Disassembly	18
Removing and Replacing the Battery Cover and Battery	18
Removing and Replacing the Subscriber Identity Module (SIM)	20
Removing and Replacing the Antenna Cover	21
Removing and Replacing the Rear Housing	22
Removing and Replacing the Transceiver Board Assembly	23
Removing and Replacing the Antenna	27
Removing and Replacing the Keypad, Volume/Smart, and Voice Keys	29
Removing and Replacing the Flip Assembly	31
Removing and Replacing the Flip Cover	32
Removing and Replacing the Flip Display Assembly	35
Subscriber Identity Module (SIM) and Identification	39
SIM Card	39
Personality Transfer	39
Identification	39
Troubleshooting	41
Programming: Software Upgrade and Flexing	43
Part Numbers	44
Related Publications	44
Exploded View Diagram	45
Exploded View Parts List	46

Introduction

Motorola® Inc. maintains a worldwide organization that is dedicated to provide responsive, full-service customer support. Motorola products are serviced by an international network of company-operated product-care centers as well as authorized independent service firms.

Available on a contract basis, Motorola Inc. offers comprehensive maintenance and installation programs that allow customers to meet requirements for reliable, continuous communications.

To learn more about the wide range of Motorola service programs, contact your local Motorola products representative or the nearest Customer Service Manager.

Product Identification

Motorola products are identified by the model number on a label usually located under the battery. Use the entire model number when inquiring about the product. Numbers are also assigned to chassis and kits. Use these numbers when requesting information or ordering replacement parts.

Product Names

Product names are listed on the front cover. Product names are subject to change without notice. Some product names, as well as some frequency bands, are available only in certain markets.

Product Changes

When electrical, mechanical or production changes are incorporated into Motorola products, a revision letter is assigned to the chassis or kit affected, for example; -A, -B, or -C, and so on.

The chassis or kit number, complete with revision number, is imprinted during production. The revision letter is an integral part of the chassis or kit number and is also listed on schematic diagrams and printed-circuit board layouts.

Regulatory Agency Compliance

This device complies with Part 15 of the FCC Rules. Operation is subject to the following conditions:

- This device may not cause any harmful interference.
- This device must accept interference received, including interference that may cause undesired operation.

This class B device also complies with all requirements of the Canadian Interference-Causing Equipment Regulations (ICES-003).

Cet appareil numérique de la classe B respecte toutes les exigences du Règlement sur le matériel brouilleur du Canada.

Computer Program Copyrights

The Motorola products described in this manual may include Motorola computer programs stored in semiconductor memories or other media that are copyrighted with all rights reserved worldwide to Motorola. Laws in the United States and other countries preserve for Motorola, Inc. certain exclusive rights to the copyrighted computer programs, including the exclusive right to copy, reproduce, modify, decompile, disassemble, and reverse-engineer the Motorola computer programs in any manner or form without Motorola's prior written consent. Furthermore, the purchase of Motorola products shall not be deemed to grant either directly or by implication, estoppel, or otherwise, any license or rights under the copyrights, patents, or patent applications of Motorola, except for a nonexclusive license to use the Motorola product and the Motorola computer programs with the Motorola product.

About This Service Manual

Use of this manual assures proper installation, operation, and maintenance of Motorola products and equipment. It contains all service information required for the equipment described and is current as of the printing date. Refer questions about this manual to the nearest Customer Service Manager.

Audience

This manual aids service personnel in testing and repairing V3x GSM telephones. Service personnel should be familiar with electronic assembly, testing, and troubleshooting methods, and with the operation and use of associated test equipment.

Scope

This manual provides basic information relating to V3x telephones, and also provides procedures and processes for repairing the phones at Level 1 and 2 service centers including:

- Unit swap out
- Repairing of mechanical faults
- Basic modular troubleshooting
- Testing and verification of unit functionality
- Initiate warranty claims and send faulty modules to Level 3 or 4 repair centers

Conventions

The following special characters and typefaces, are used in this manual to emphasize certain types of information.



Note: Emphasizes additional information pertinent to the subject matter.



Caution: Emphasizes information about actions which may result in equipment damage.



Warning: Emphasizes information about actions which may result in personal injury.



Keys to be pressed are represented graphically. For example, instead of “Press the Menu Key”, you will see “Press 

Information from a screen is shown in text as similar as possible to what displays on the screen. For example, **ALERTS** or `ALERTS`.

Information that you need to type is printed in **boldface type**.

Warranty Service Policy

The product is sold with the standard 12-month warranty terms and conditions. Accidental damage, misuse, and extended warranties offered by retailers are not supported under warranty. Non-warranty repairs are available at agreed fixed repair prices.

Out-of-Box Failure Policy

The standard out-of-box failure criteria applies. Return customer units that fail very early on after the date of sale to Manufacturing for root cause analysis, to guard against epidemic criteria. Manufacturing to bear the costs of early life failure.

Product Support

Customer's original units will be repaired but not refurbished as standard. Appointed Motorola Service Hubs will perform warranty and non-warranty field service for level 2 (assemblies) and level 3 (limited PCB component). Motorola High Tech Centers will perform level-4 (full component) repairs.

Customer Support

Customer support is available through dedicated Call Centers and in-country help desks. Product Service training is available through the local Motorola Support Center.

Parts Replacement

When ordering replacement parts or equipment, include the Motorola part number and description used in this service manual.

When the Motorola part number of a component is not known, use the product model number or other related major assembly along with a description of the related major assembly and of the component in question.

In the U.S.A., to contact Motorola, Inc. on your TTY, call: 800-793-7834.

Accessories and Aftermarket Division (AAD)

Order replacement parts, test equipment, and manuals from AAD.

U.S.A.

Phone: 800-422-4210

FAX: 800-622-6210

Website: <http://businessonline.motorola.com>

Outside U.S.A.

Phone: 847-538-8023

FAX: 847-576-3023

EMEA

Phone: +49 461 803 1404

Website: <http://emeaonline.motorola.com>

Asia

Phone: +65 648 62995

Website: <http://asiaonline.motorola.com>

Specifications

Table 1. Specifications

Function	Specification
Frequency Range EGSM	TX: 880 - 915 MHz Frequency (MHz) = $890 + (0.2 \times n)$ where: $0 \leq n \leq 124$ Frequency (MHz) = $890 + (0.2 \times (n - 1024))$ where: $955 \leq n \leq 1023$ RX: 925 - 960 MHz Frequency (MHz) = $935 + (0.2 \times n)$ where: $0 \leq n \leq 124$ Frequency (MHz) = $935 + (0.2 \times (n - 1024))$ where: $955 \leq n \leq 1023$
Frequency Range DCS	TX: 1710 to 1785 MHz Frequency (MHz) = $1710.2 + (0.2 \times (n - 512))$ where: $512 \leq n \leq 885$ RX: 1805.2 to 1879.8 MHz Frequency (MHz) = $1805.2 + (0.2 \times (n - 512))$ where: $512 \leq n \leq 885$
Frequency Range PCS	TX: 1850 to 1910 MHz Frequency (MHz) = $1850.2 + (0.2 \times (n - 512))$ where: $512 \leq n \leq 810$ RX: 1930 to 1990 MHz Frequency (MHz) = $1930.2 + (0.2 \times (n - 512))$ where: $512 \leq n \leq 810$
Frequency Range UMTS	TX: 1920 to 1980 MHz Frequency (MHz) = $UARFCN^1 + 5$, where: $9612 \leq UARFCN^1 \leq 9888$ UARFCN ¹ in increments of 25 RX: 2110 to 2170 MHz Frequency (MHz) = $UARFCN^1 + 5$, where: $10562 \leq UARFCN^1 \leq 10838$ UARFCN ¹ in increments of 25
Channel Spacing	200 kHz (GSM, DCS, PCS), 5 MHz UMTS
Channels	174 EGSM, 374 DCS, 274 PCS carriers with 8 channels per carrier, 11 UMTS
Duplex Spacing	45 MHz GSM, 95 MHz DCS, 80 MHz PCS, 190 MHz UMTS
Modulation	GMSK AT BT = 0.3 (GSM, DCS, PCS), QPSK (UMTS)
Transmitter Phase Accuracy	5 degrees RMS, 20 Degrees peak
Frequency Error	± 0.1 ppm
Input/Output Impedance	50 ohms (nominal)
Nominal Operating Voltage	3.6 Vdc $\pm 10\%$ (battery) +4.4 Vdc $\pm 10\%$ (external connector)
Size	89 cc
Weight	118 g
Display	Main Display: 262K color TFT, 320 x 240, 2.2" CLI Display: 65K color STN, 96x80, 1"
Battery Life (840mAh) ²	GSM: Talk time: Up to 215 minutes GSM: Standby time: Up to 220 to 260 hours WCDMA Talk time: 131 hours WCDMA Standby time: 227 hours WCDMA Video talk time: Up to 90 minutes
Nominal Operating Temperature Range	-10° C to +55° C

GSM System Functions	Specification
Speech Coding Type	Regular Pulse excitation / linear predictive coding with long term prediction (RPE LPC with LTP)
Bit Rate	13.0 kbps
RF Power Output	32 dBm nominal GSM, 28.5 dBm nominal DCS / PCS
Spurious Emissions	-36 dBm from 0.1 to 1 GHz, -30 dBm from 1 to 4 GHz
Receive Sensitivity	-102 dBm GSM, -102 dBm DCS / PCS
RX Bit Error Rate	< 2%

UMTS System Functions	Specification
Speech Coding Type	Adaptive Multirate (AMR)
RF Power Output	21 dBm
Spurious Emissions	-36 dBm from 0.1 to 1 GHz, -30 dBm from 1 to 4 GHz
Error Vector Magnitude	< 17.5%
PN9 Bit Error Rate (VER)	0.1% @12.2K, -106.7 dBm
ACLR	-33 dBm @±5 MHz, -43 dBm @±10 MHz

Product Overview

Motorola V3x telephones deliver 3G features in a small and lightweight package. These Global System for Mobile communications (GSM) General Packet Radio Service (GPRS) Wireless Application Protocol (WAP)-enabled mobile phones incorporate an icon based User Interface (UI) for easier operation, allows Short Message Service (SMS) text messaging, Multi-media Messaging Services (MMS), and includes Personal Information Manager (PIM) functionality. V3x is a tri-band phones that allow roaming within the GSM 900 MHz, 1800 MHz Digital Cellular System (DCS), and PCS 1900 MHz bands, in addition to the UMTS WCDMA 2100 MHz band.

V3x telephones have a clam form factor. They feature an externally viewable 96 x 80 65K color STN CLI display for caller identification with date/time, and an internal 320 x 240 262K TFT color display located in the flip. The bottom part of the clam (front housing) contains the keypad, transceiver printed circuit board (PCB), microphone, flex connection, external accessory connector, smart button, volume buttons, and voice button. The standard 840 mAh Lithium Ion (Li Ion) battery fits behind a removable back cover and provides up to 220 minutes of talk time and 200 hours of standby time in GSM mode. The battery provides up to 131 minutes of talk time, and up to 227 hours of standby time in WCDMA mode.

The phone accepts 3V Subscriber Identity Module (SIM) cards that fit into the SIM holder under the battery. The antenna is a fixed stub type antenna. Inexpensive direct connection to a computer or handheld device through USB for data and fax calls, and for synchronizing phonebook entries with Motorola mobile Phone Tools™ software, can be accomplished using the optional data cable and soft modem.

Features

V3x telephones use advanced, self-contained, sealed, custom integrated circuits to perform the complex functions required for WCDMA communication. Aside from the space and weight advantage, microcircuits enhance basic reliability, simplify maintenance, and provide a wide variety of operational functions.

Other features available in this family of telephones include:

- WCDMA 2100 MHz, GSM/GPRS 900/1800/1900 MHz
- Bluetooth Class 2

Physical

- Width 53mm
- Height 99mm
- Depth 19.8 mm
- Volume 89 cc
- Weight 118.0 grams

Audio

- AAC
- AAC+
- WAV
- MP3
- AAC+ Enhanced
- XMF
- RA v9

- MIDI

Video

- MPEG4 Video clip playback

Display

- Main display 320 x 240 pixel 262k TFT
- CLI display 96 x 80 65k CSTN

Memory

- 64 MB internal RAM
- 32 MB internal ROM
- 64 MB internal ROM user memory
- Accepts removable TransFlash memory (16, 32 64, 128, 256 or 512MB) modules

Imaging

- Primary camera resolution 2.0 MP
- Secondary camera resolution VGA
- Dedicated camera key

Wireless Access Protocol (WAP) 2.0 Compliancy

In the WAP environment, access to the Internet is initiated in Wireless Markup Language (WML), which is derived from Hypertext Markup Language (HTML). The request is passed to a WAP gateway, which retrieves the information from the server in standard HTML (subsequently filtered to WML) or directly in WML if available. The information is then passed to the mobile subscriber using the mobile network.



Bitmap image data will download as text. If the image is larger than the screen, only part of the image will display.



When the user receives a call while in browser mode, the browser will pause and allow the user to resume after completing the call.

SIM Application Toolkit™ - Class 2

SIM Application Toolkit is a value-added service software product that allows GSM operators to customize the services they offer their customers, from the occasional user who requests sports news and traffic alerts, to a high call time business user who receives stock alerts and checks flight times. Operators can now create their own value-added services menu quickly and easily in the phone. The customized menu will appear as the first menu and may be updated over-the-air with new services when customers request them.

Simplified Text Entry

There are three different ways to enter text using the phone keypad:

- iTAP predictive text entry. Press a key to enter a character, and a dynamic dictionary uses this to build and display a set of word or name options. The iTAP feature may not be available on the phone in all languages.
- Tap. Press a key to enter a character.
- Numeric. The keypad produces numeric characters only. For some text areas, such as phone numbers, this is the only method available.

Caller Line Identification

Upon receipt of a call, the calling party's phone number is compared to the phonebook. If the number matches a phone book entry, that name will be displayed. If there is no phone book entry, the incoming phone number will be displayed. If no caller identification information is available, the Incoming Call message is displayed.



The user must subscribe to a caller line identification service through their service provider.

Other Features

Detailed descriptions of these and the other features can be found in the appropriate user's guide listed in the "Related Publications" section toward the end of this manual.

General Operation

Controls, Indicators, and Input / Output (I/O) Connections

The V3x telephone's controls are located on the sides of the phone and on the keypad. Indicators, in the form of icons, are displayed on the LCD (see Figure 2). V3x phones have an audible alert transducer on the top and I/O connectors, consisting of a headset jack and an accessory port, located on the side and bottom of the phone See Figure 1.

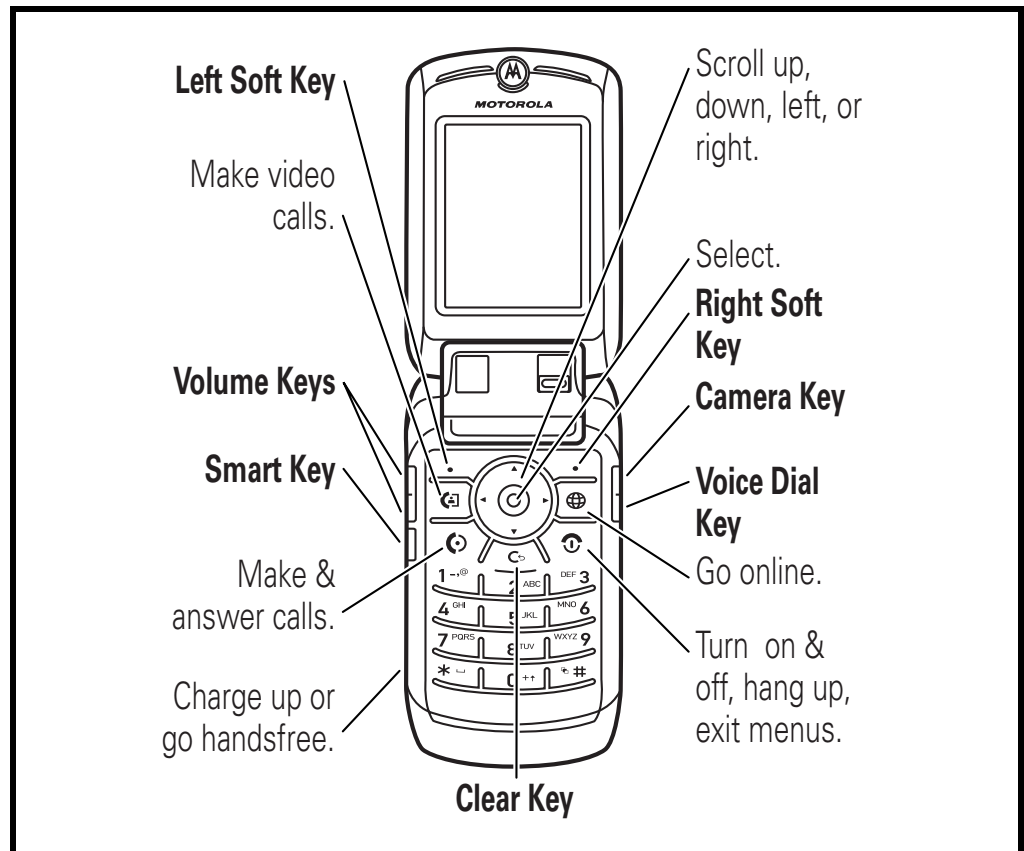

0505920

Figure 1. Telephone Controls, indicators, and I/O Connections

Main Display

The main display provides a 262k color backlit display for easy readability in all light conditions. The 320 x 240 display provides room for text, graphics, icons, and prompts.

Display animation makes the phone's menus move smoothly as the user scrolls up and down. Turn animation off to conserve the battery. Figure 2 shows common icons displayed on the LCD.

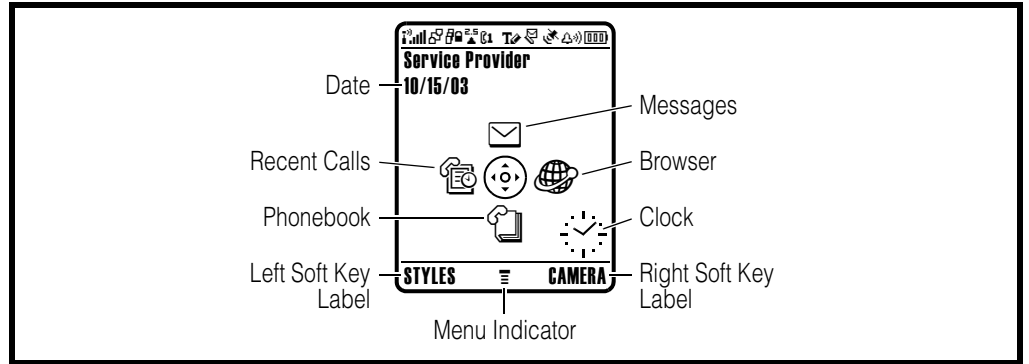

Figure 2. Icon Indicators

031422o



Whether a phone displays all indicators depends on the programming and services to which the user subscribes.

Alert Settings

V3x telephones include up to 32 preset ring tones and vibrations that can be applied to all alert events at the same time.



Pressing either volume key will mute the alert.

Battery Function

Battery Gauge

The telephone displays a battery level indicator icon in the idle screen to indicate the battery charge level. The gauge shows four levels: 100% (▣▣▣▣), 66% (▣▣▣), 33% (▣▣), and Low Battery (▣).

Battery Removal

Removing the battery causes the phone to immediately shut down and any pending work (for example, partially entered phone book entries or outgoing messages) is lost.



To ensure proper memory retention, turn OFF the phone before removing the battery.



If the battery is removed while receiving a message, the message will be lost.

Operation

For detailed operating instructions, refer to the appropriate user's guide listed in "Related Publications" on page 44.

Tools and Test Equipment

Table 1 lists tools and test equipment recommended for disassembly and reassembly of V3x telephones. Use either the listed items or equivalents.

Table 1. General Test Equipment and Tools

Motorola Part Number ¹	Description	Application
RSX4043-A	Torque Driver	Used to remove and replace screws.
—	Torque Driver Bit T-5, T-6 Plus, Apex 440-6IP Torx Plus or equivalent	Used with torque driver.
See Table 7	Rapid Charger	Used to charge battery and to power phone.
0180386A82	Antistatic Mat Kit (includes 66-80387A95 antistatic mat, 66-80334B36 ground cord, and 42-80385A59 wrist band)	Provides protection from damage to device caused by electrostatic discharge (ESD).
0-00-00-30005	Disassembly tool, plastic with flat and pointed ends (manual opening tool)	Used during assembly/disassembly of phone.
—	Tweezers, Plastic	Used during assembly/disassembly of phone.
—	Digital Multimeter, HP34401A ²	Used to measure battery voltage.
8102430Z04	GSM / DCS Test SIM	Used to enable manual test mode.

1. To order in North America, contact Motorola Aftermarket and Accessories Division (AAD) at (800) 422-4210 or FAX (800) 622-6210; Internationally, AAD can be reached by calling (847) 538-8023 or faxing (847) 576-3023.

2. Not available from Motorola. To order, contact Hewlett Packard at (800) 452-4844.

Disassembly

This section provides instructions for the disassembly of V3x telephones. Tools and equipment used for the phone are listed in Table 1, preceding.



Many of the integrated devices used in these phones are vulnerable to damage from ESD. Ensure adequate static protection is in place when handling, shipping, and servicing the internal components of this phone.



Avoid stressing the plastic in any way to avoid damage to either the plastic or internal components.

Removing and Replacing the Battery Cover and Battery



All batteries can cause property damage and/or bodily injury, such as burns, if a conductive material, such as jewelry, keys, or beaded chains, touches exposed terminals. The conductive material may complete an electrical circuit (short circuit) and become very hot. Use care in handling any charged battery, particularly when placing it inside a pocket, purse, or other container with metal objects.

1. Ensure the phone is turned off.
2. Press down on the battery latch and then slide the battery cover as shown in Figure 1.

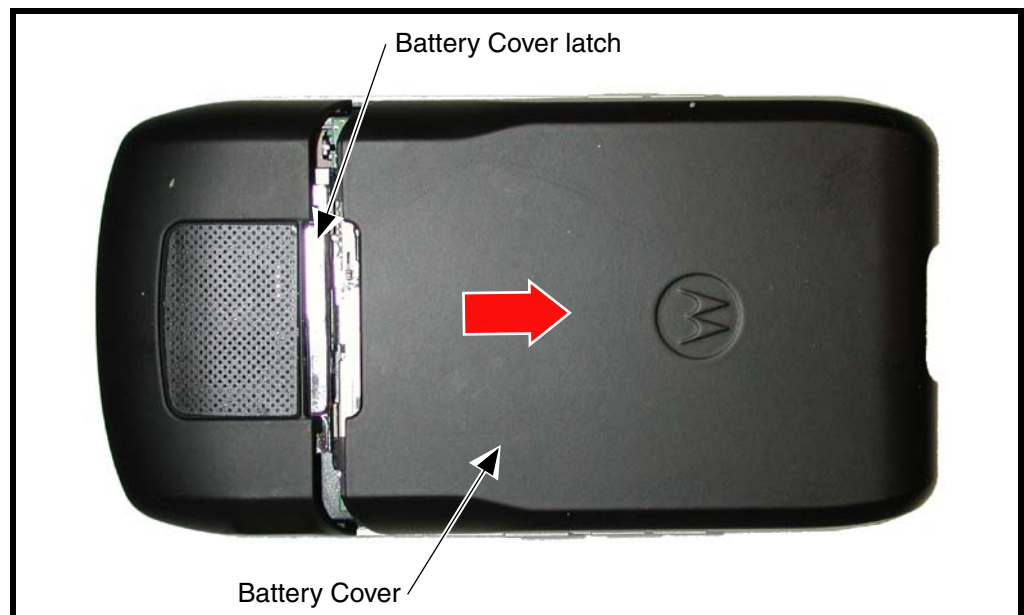

Figure 1. Removing the Battery Cover

0512090

3. Lift the battery cover away from the phone.

4. Lift the bottom end of the battery first and then lift the battery out the phone. (see Figure 2).

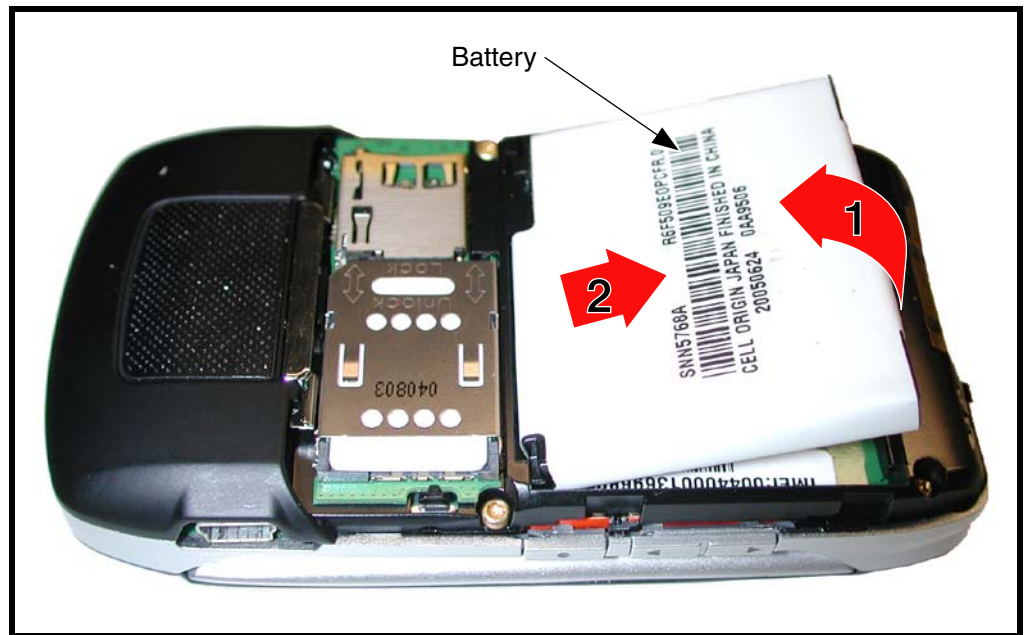

Figure 2. Removing the Battery

051210o



There is a danger of explosion if the Lithium Ion battery is replaced incorrectly. Replace only with the same type of battery or equivalent as recommended by the battery manufacturer. Dispose of used batteries according to the manufacturer's instructions.

5. To replace, align the battery with the battery compartment so the contacts on the battery match the battery contacts in the phone.
6. Insert the battery, top end first, into the battery compartment and push down.
7. Insert the bottom edge of the battery housing into the base of the phone, then slide the battery cover over the battery and snap it into place.

Removing and Replacing the Subscriber Identity Module (SIM)

1. Remove the battery door and battery as described in the procedures.
2. Slide the SIM holder as indicated in Figure 3.
3. Open the SIM holder.
4. Carefully lift the SIM out of the phone.

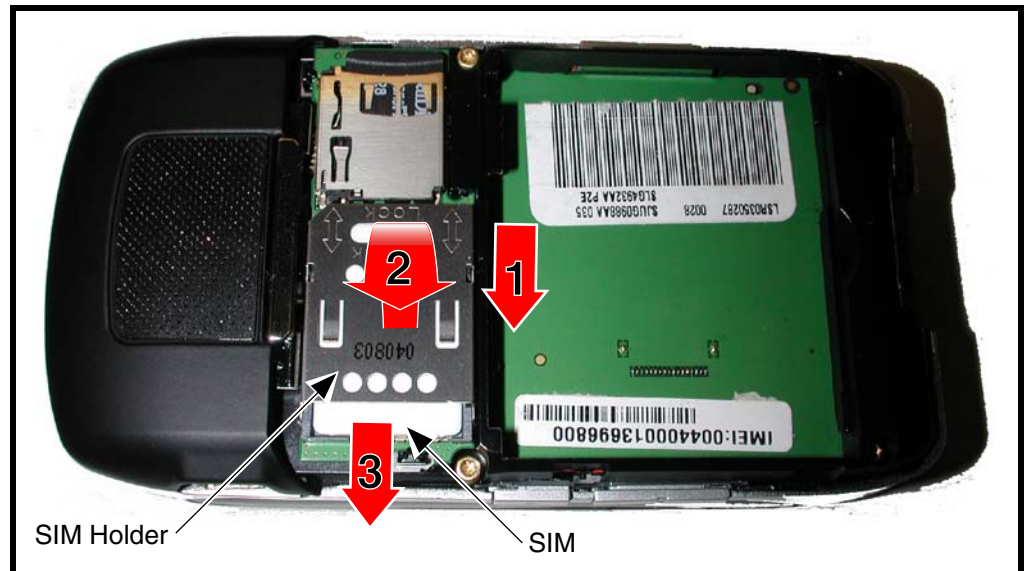

051262o

Figure 3. Removing the SIM

5. To replace, place the SIM into the holder, ensuring the keyed corner of the SIM aligns with the notch molded into the holder.
6. Close the SIM holder.
7. Slide the SIM holder in the opposite direction to lock it.
8. Replace the battery and battery cover as described in the procedures.

Removing and Replacing the Antenna Cover

1. Remove the battery cover, battery and SIM, as described in the procedures.
2. Insert the disassembly tool under each side of the antenna cover to release the antenna cover latches (see Figure 4).

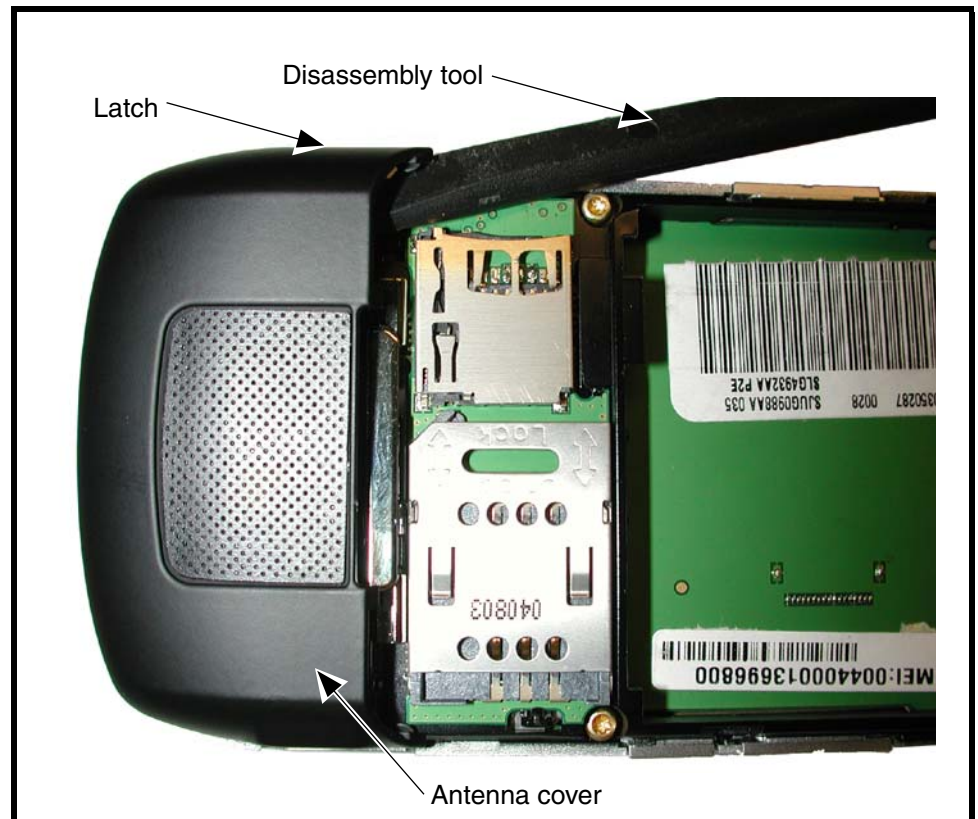

051212o

Figure 4. Removing the Antenna Cap

3. Carefully lift the antenna cover away from the phone.
4. To replace, align the antenna cover over the antenna.
5. Place the curved edge of the antenna cover onto the phone.
6. Carefully press the straight edge of the antenna cover into place until the latches snap into place.
7. Insert the RF grommet fully into the opening on the antenna cover.
8. Reassemble the SIM, battery, and battery cover as described in the procedures.

Removing and Replacing the Rear Housing



This product contains static-sensitive devices. Use anti-static handling procedures to prevent electrostatic discharge (ESD) and component damage.

1. Remove the battery cover, battery, SIM, and antenna as described in the procedures.
2. Using a Torx driver with a T-6 bit, remove the 6 screws along the sides of the phone (see Figure 5).

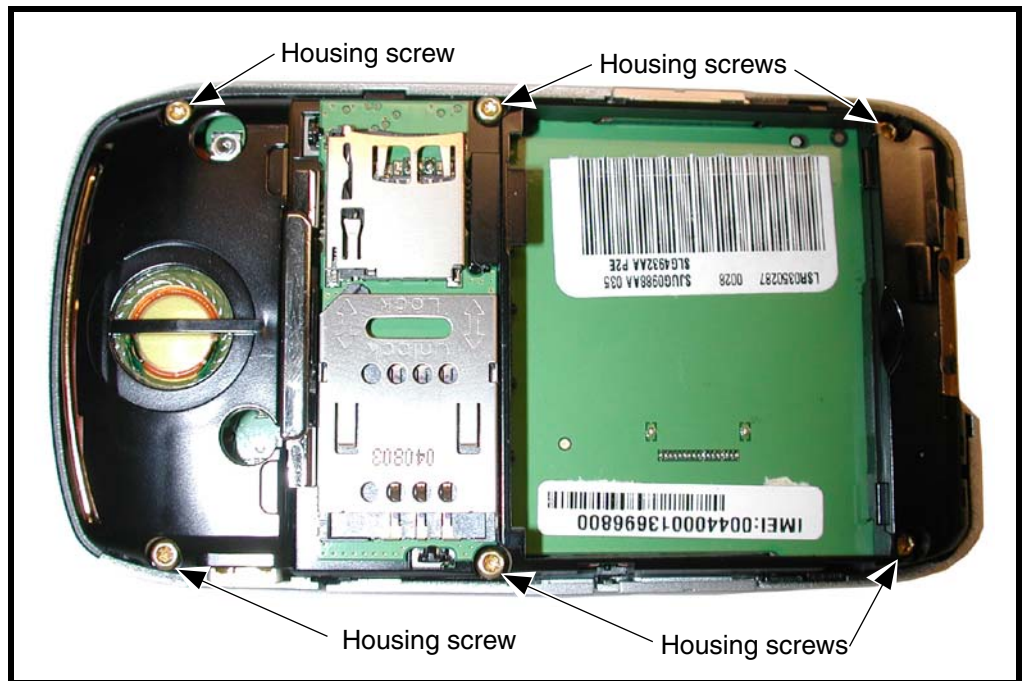

0512170

Figure 5. Removing the Rear Housing Screws

- Carefully lift the rear housing away from the phone.

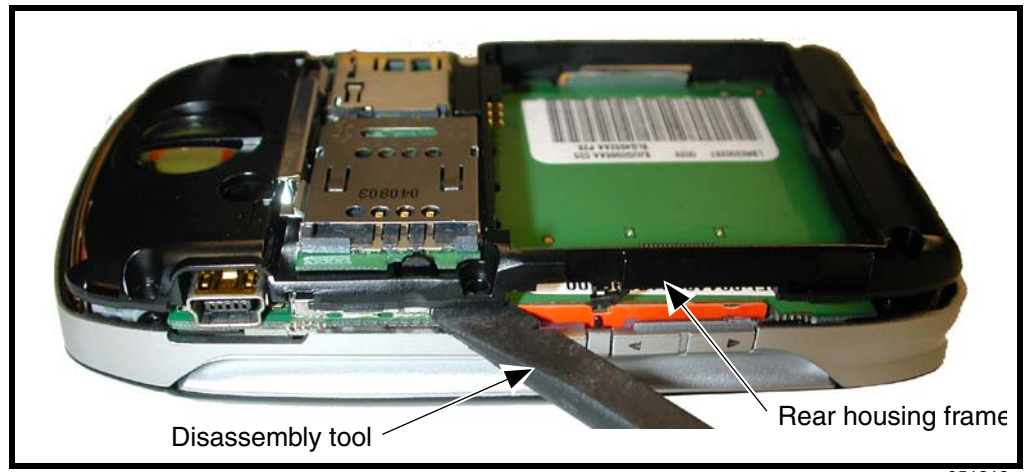

Figure 6. Removing the Rear Housing

0512180

- Lower the rear housing onto the phone. Ensure the screw holes are aligned to the transceiver PCB assembly.
- Insert the 6 housing screws and tighten to a torque setting of 1.5 inch pounds or 16 N/cm (Newton/centimeters). Do not over tighten.
- Replace the SIM, battery, and battery cover as described in the procedures.

Removing and Replacing the Transceiver Board Assembly



This product contains static-sensitive devices. Use anti-static handling procedures to prevent ESD and component damage.

- Remove the battery cover, battery, SIM, antenna, and rear housing as described in the procedures..



The flexible printed cable (FPC) (flex) is easily damaged. Exercise extreme care when handling.

- Carefully work the flat end of the disassembly tool under the flex connector and unseat the connector from its socket the transceiver board (see Figure 7).

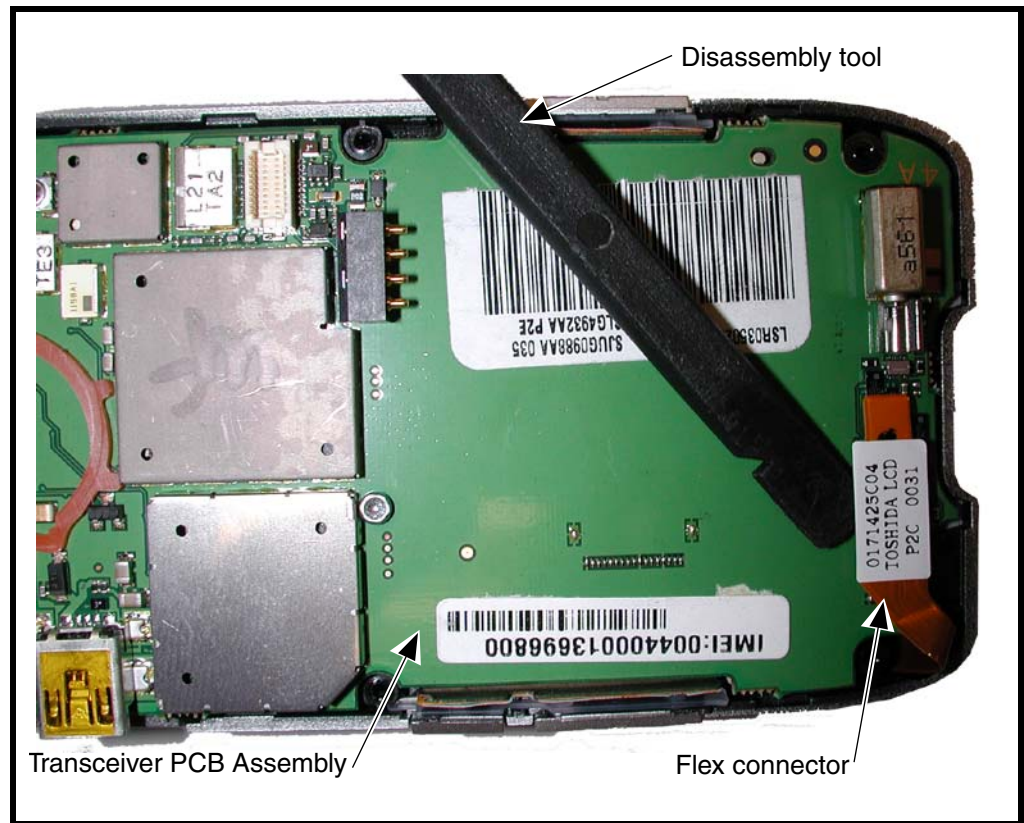
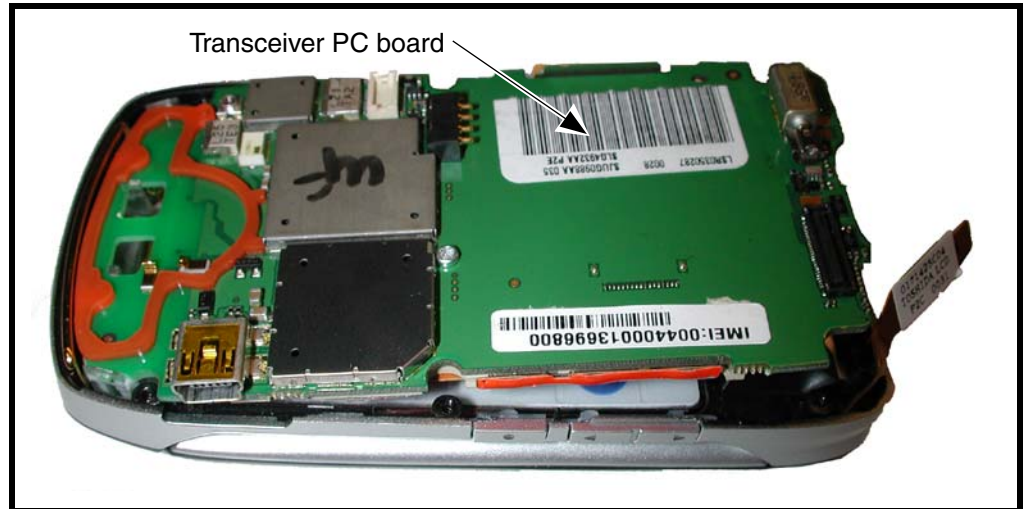

Figure 7. Disconnecting the Flex From the Transceiver Board

0512190

3. Lift the transceiver board assembly and the keypad switchdome assembly out of the front housing (see Figure 8).



051222o

Figure 8. Removing the Transceiver Board Assembly

4. Use the T6 driver to remove the screw in the middle of the transceiver PC board assembly (see Figure 9). Set the screw aside for re-use.

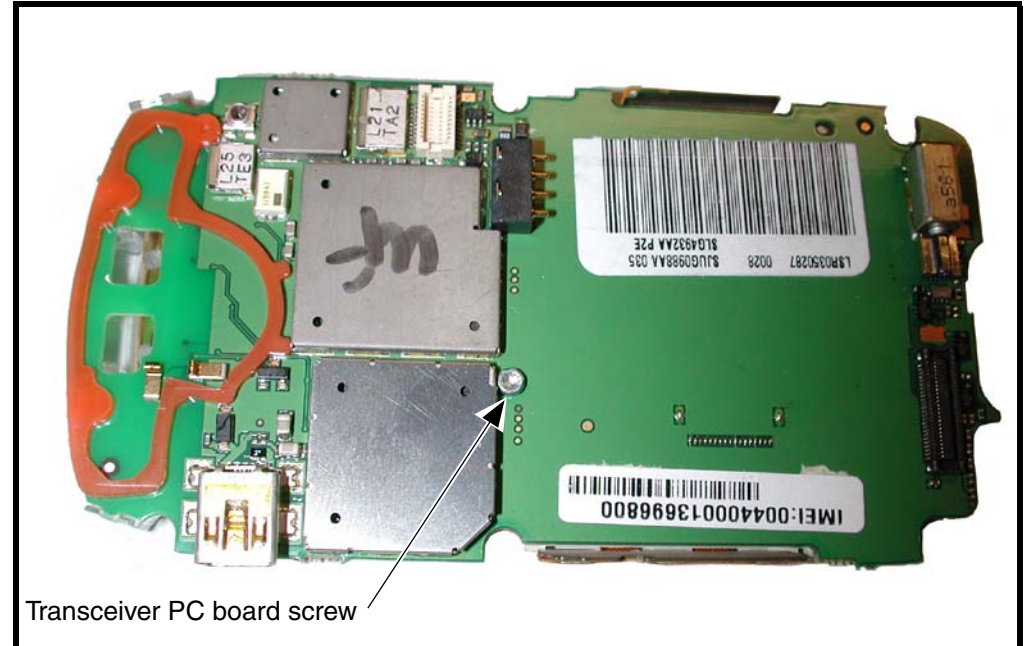

051233o

Figure 9. Removing Transceiver PC Board Screw

5. Turn the Transceiver PC board assembly over and use the disassembly tool to unseat the popple dome board flex connector (see Figure 10).

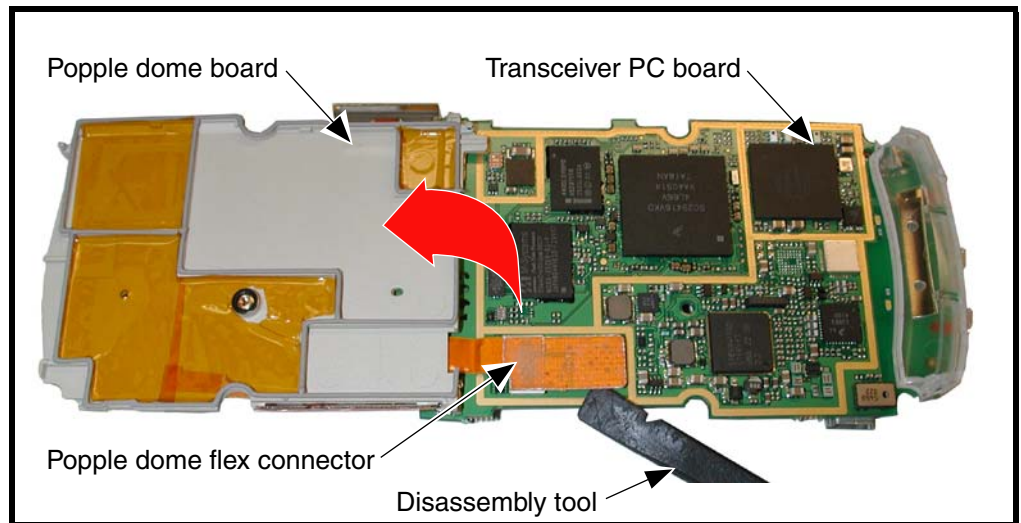

051235o

Figure 10. Removing the Popple dome FLEX Connector

6. Separate the popple dome board from the transceiver PC board assembly.
7. To replace,
8. Insert the popple dome flex connector squarely into its mating connector on the transceiver board and press firmly until it snaps into place.
9. Turn the popple dome board over onto the transceiver PC board.
10. Insert and tighten the transceiver PC board screw with the T6 driver to a torque setting of 13 N/cm. Do not overtighten.
11. Carefully place the transceiver board and the switchdome assembly into the front housing.
12. Insert the display flex connector squarely into its mating connector on the transceiver board and press firmly until it snaps into place.
13. Replace the rear housing, antenna, SIM, battery, and battery cover as described in the procedures.

Removing and Replacing the Antenna

1. Remove the battery cover and battery, SIM, rear housing, and transceiver board assembly as described in the procedures.
2. Use the disassembly tool to pry the antenna out of the antenna assembly.

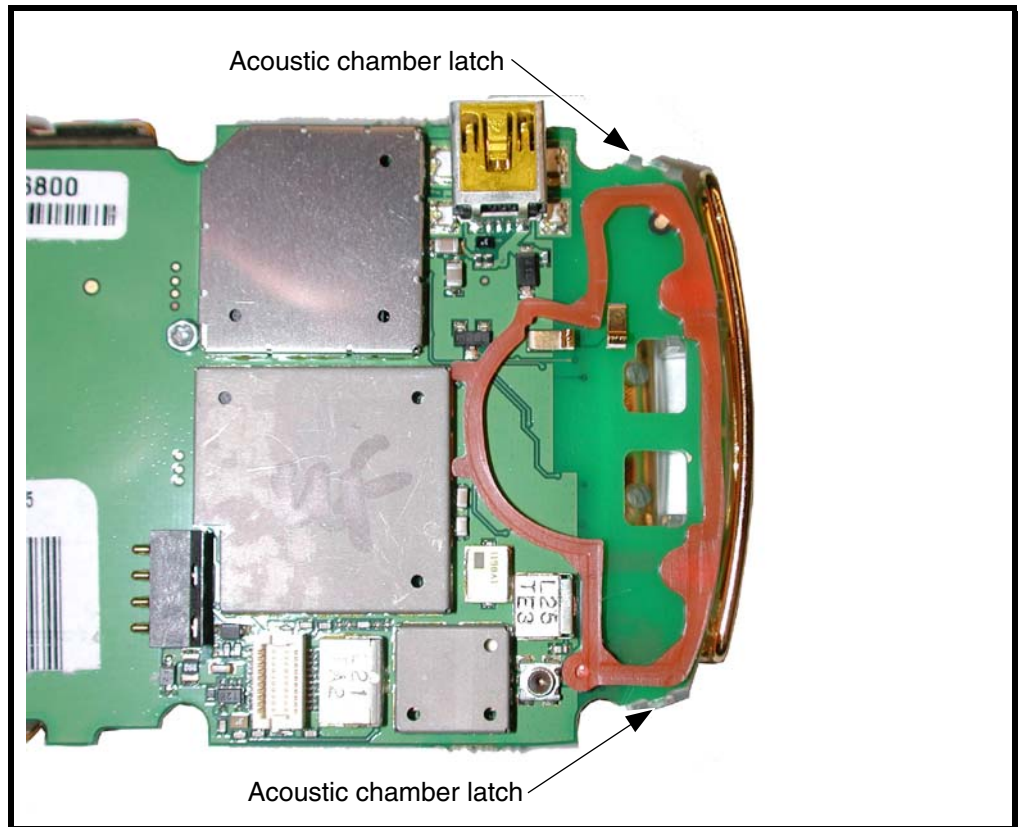

0516930

Figure 11. Removing the Antenna Assembly

3. Unlatch the latches that secure the acoustic assembly to the transceiver PC board.
4. Lift the acoustic chamber assembly away from the transceiver PC board.

5. Use the disassembly tool to gently pry the antenna out of the acoustic chamber.

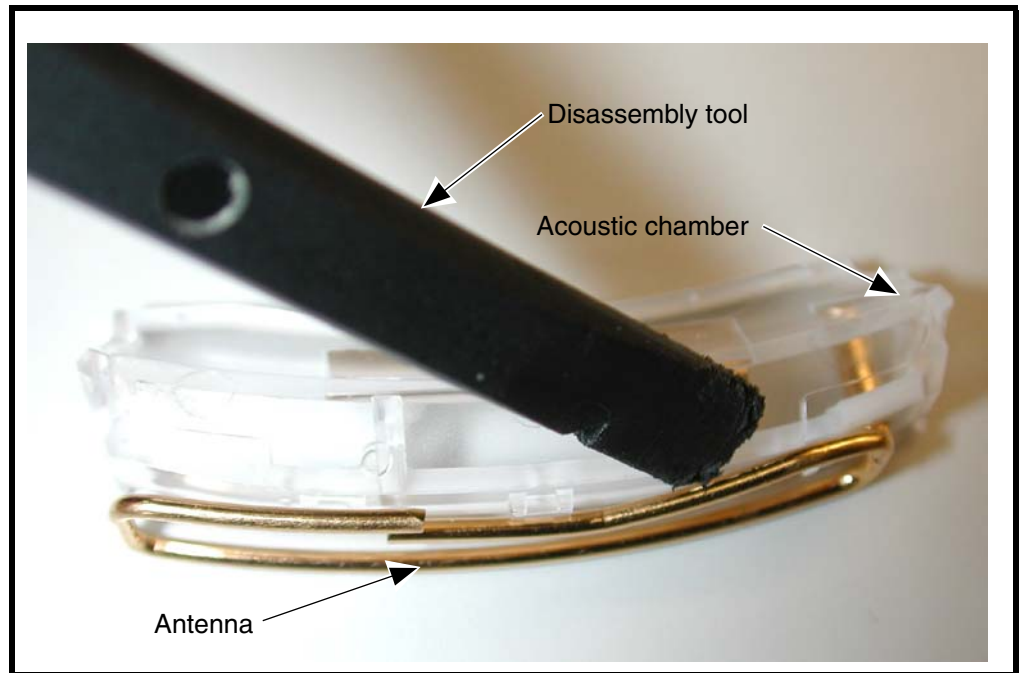

051694o

Figure 12. Removing the Antenna

6. To replace, insert the antenna into the acoustic chamber assembly.
7. Align the acoustic chamber assembly to the transceiver PC board and gently press into position. Ensure the latches are secured to the PC board.
8. Replace the transceiver PC board assembly, rear housing, SIM, battery and battery cover as described in the procedures.

Removing and Replacing the Keypad, Volume/Smart, and Voice Keys

1. Remove battery cover, battery, SIM, antenna, rear housing, and transceiver board assembly as described in the procedures.
2. Use the plastic tweezers to lift the volume/smart keys out of their slot in the front housing (see Figure 14).

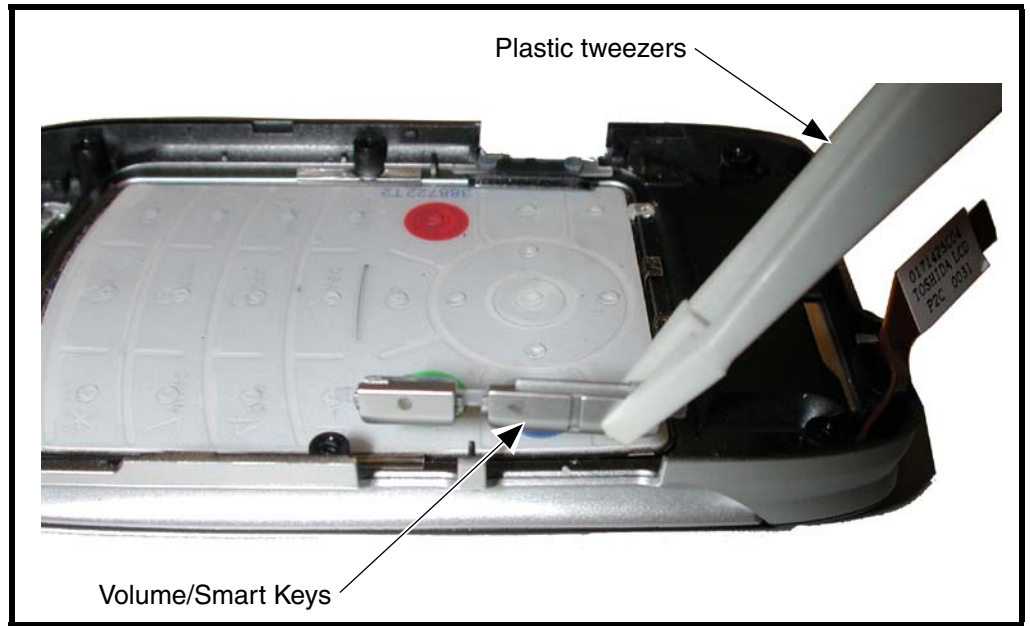

0512230

Figure 13. Removing the Keypad, Volume/Smart, and Voice Buttons

3. Use the plastic tweezers to lift the keypad assembly away from the front housing (see Figure 14).

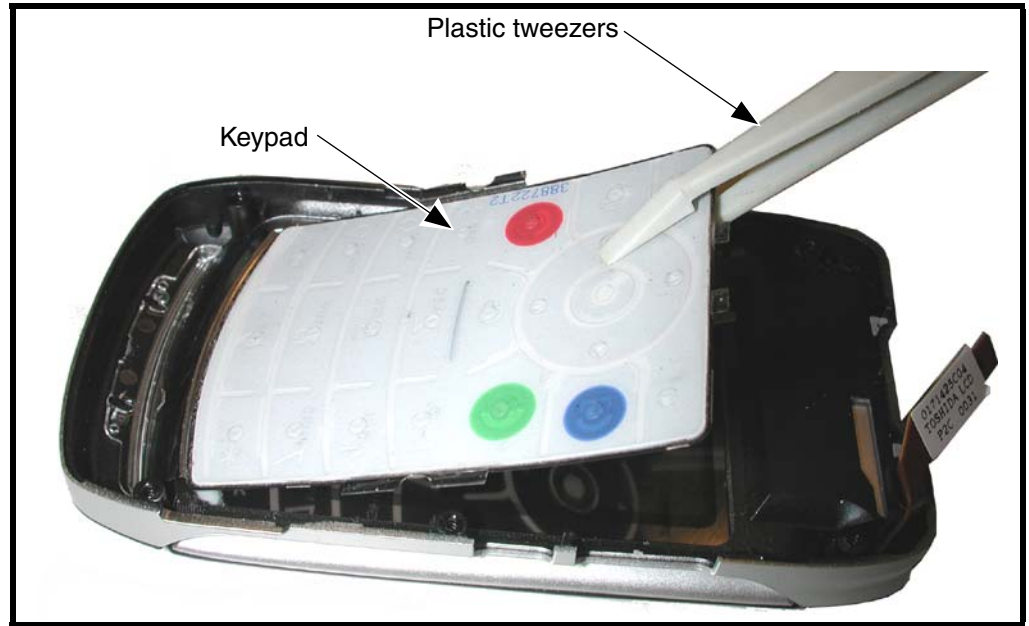
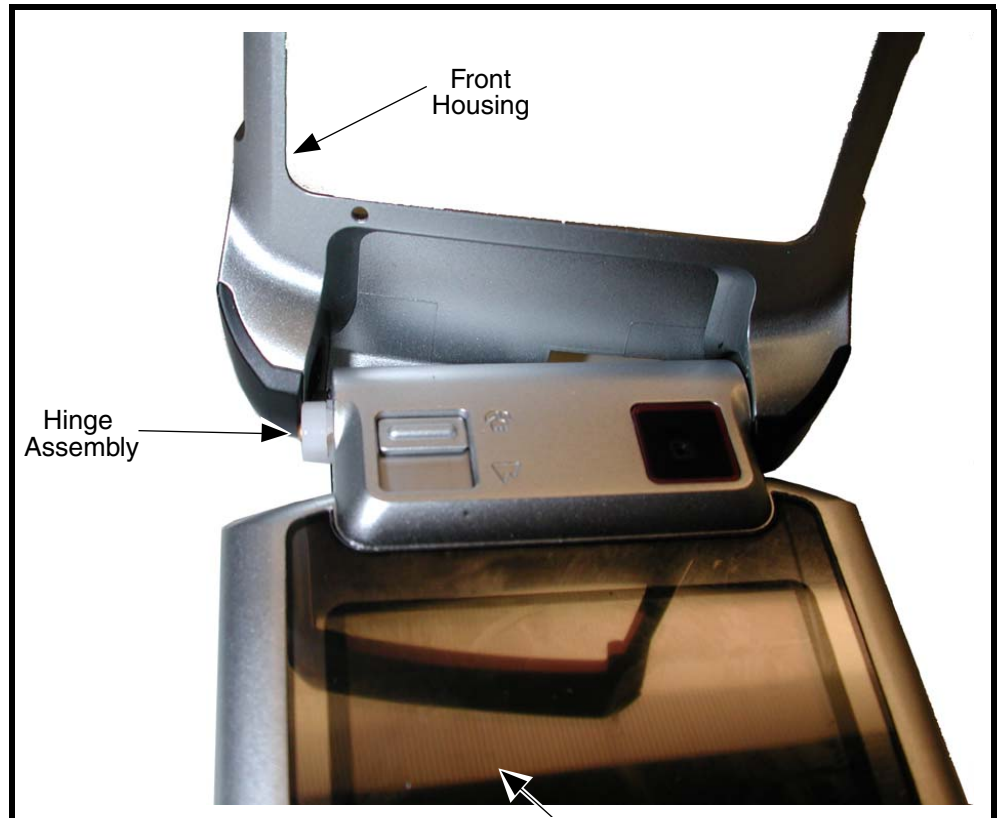

Figure 14. Removing the Keypad

4. To replace, insert the keypad into the front housing, ensuring the keys align properly with the openings in the front housing.
5. Carefully set the keypad volume/smart buttons and voice button assembly onto the metal switchdome assembly. Ensure the volume/smart key make contact with the switchdome assembly on the transceiver board when installed.
6. Replace the transceiver board assembly, display flex connector, rear housing assembly, antenna, SIM, battery, and battery cover as described in the procedures.

Removing and Replacing the Flip Assembly

1. Remove the battery cover, battery, SIM, antenna, rear housing, transceiver board assembly, and keypad assembly as described in the procedures.
2. Carefully flex the base inner front housing downward to release the hinge assembly from the front housing (see Figure 15).



0512260

Figure 15. Removing the Flip Assembly

3. Carefully slide the display flex cable and connector through the housing assembly. Avoid damage to the flex cable.



The flexible printed cable (FPC) (flex) is easily damaged. Exercise extreme care when handling.

4. Lift the housing assembly away from the flip assembly. Be careful not to damage the display flex cable.
5. To replace, carefully thread the display flex connector through the slot on the keypad housing assembly. Avoid damaging the flex cable.
6. Flex the front housing slightly and insert the hinge assembly into the front housing. Avoid damaging the flex cable and connector.
7. Replace the keypad assembly, transceiver board assembly, rear housing, antenna, SIM, battery, and battery cover as described in the procedures.

Removing and Replacing the Flip Cover

1. Remove the battery cover, battery, SIM, antenna, rear housing, transceiver board assembly, keypad assembly and flip assembly as described in the procedures.
2. Use the metal tweezers to remove the 2 flip screw covers at the top of the flip assembly (see Figure 16).

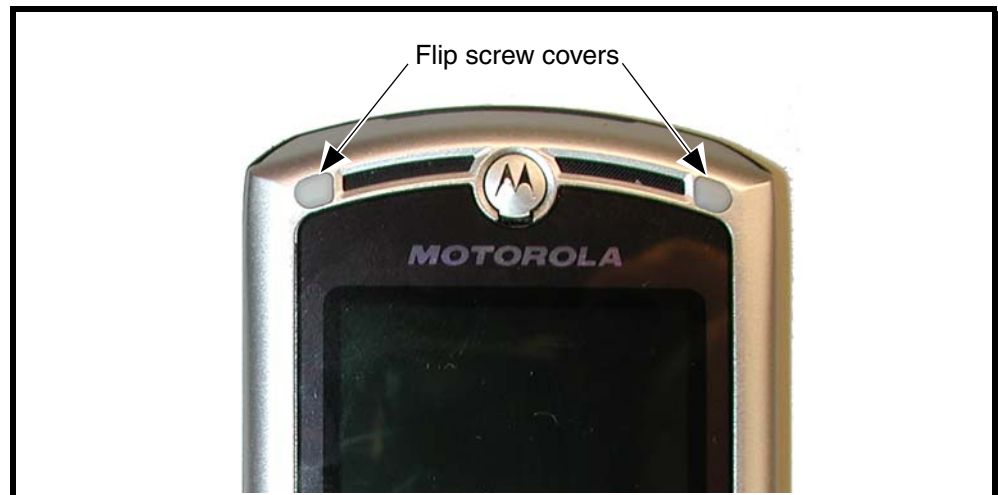

051246o

Figure 16. Removing the Flip Cover Screws

3. Use a T5 bit to remove 2 flip screws at the top of the flip assembly located under the screw covers. Set the screws aside for reuse unless they are damaged.

4. Insert the tip of a thin bladed knife under the display lens starting under the Motorola logo and pry it upward.

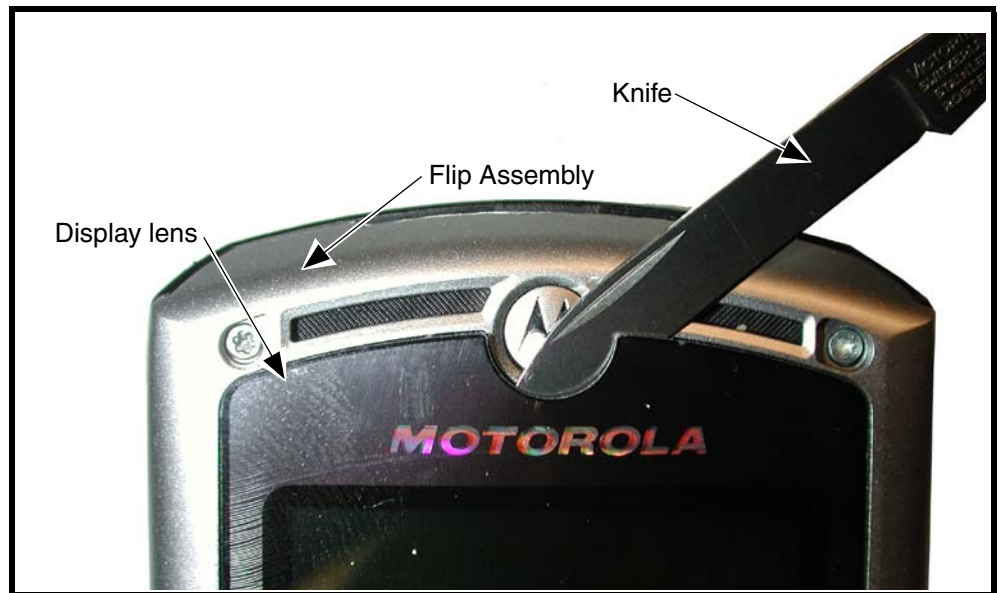

051244o

Figure 17. Removing the Display Lens

5. Slide the pointed edge under the edge of the display lens to separate it from the flip assembly and remove it from the flip assembly.
6. Use the T-5 driver to remove the 2 flip assembly screws at the bottom of the flip assembly. Set the screws aside for re-use unless they are damaged.



052145o

Figure 18. Removing the Bottom Flip Screws

7. Insert the disassembly tool between the flip assembly and the flip housing to release the 3 latches on each side of the flip assembly (see Figure 17).

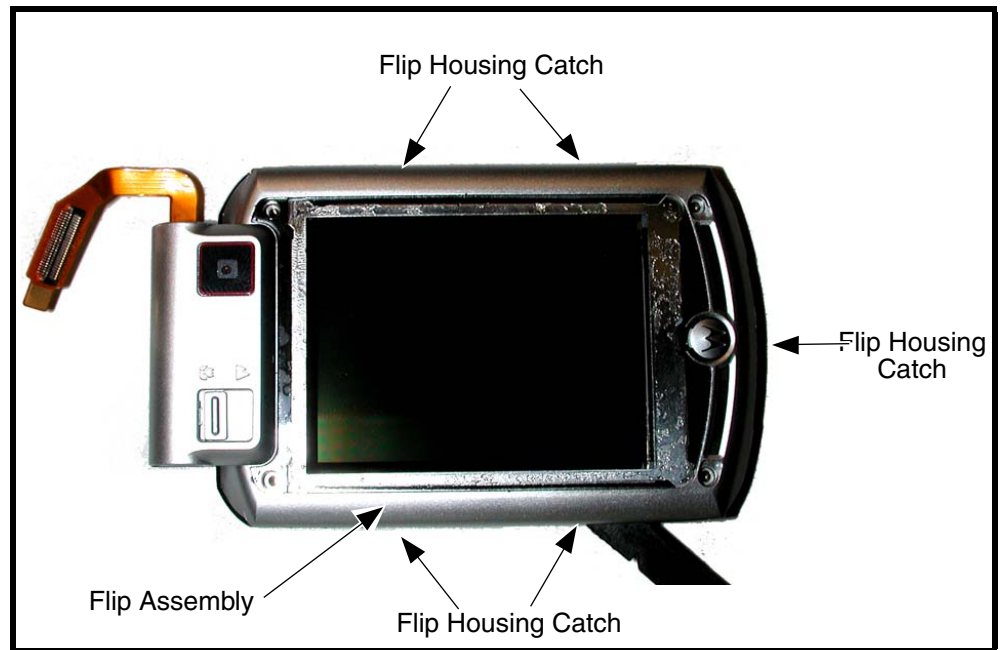

0409580

Figure 19. Removing the Display Lens

8. Carefully lift the flip cover away from the flip assembly. Avoid damaging the display flex cable and connector.
9. To replace, align the flip cover with the flip assembly. Press the flip cover onto the flip assembly until the 6 latches are fully engaged.
10. Insert and tighten the 4 flip screws with the T5 driver to a final torque setting of 13 N/cm. Do not overtighten.
11. Remove the adhesive from the back of the new display lens and apply lens to the flip housing.
12. Replace the flip assembly, keypad assembly, transceiver board assembly, rear housing, antenna, SIM, battery, and battery cover as described in the procedures.

Removing and Replacing the Flip Display Assembly

1. Remove the battery cover, battery, SIM, antenna, rear housing, transceiver board assembly, keypad assembly, flip assembly, and flip cover as described in the procedures.



The flexible printed cable (FPC) (flex) is easily damaged. Exercise extreme care when handling.

2. Use the disassembly tool to unseat the flip assembly flex connector from the display assembly (see Figure 20).

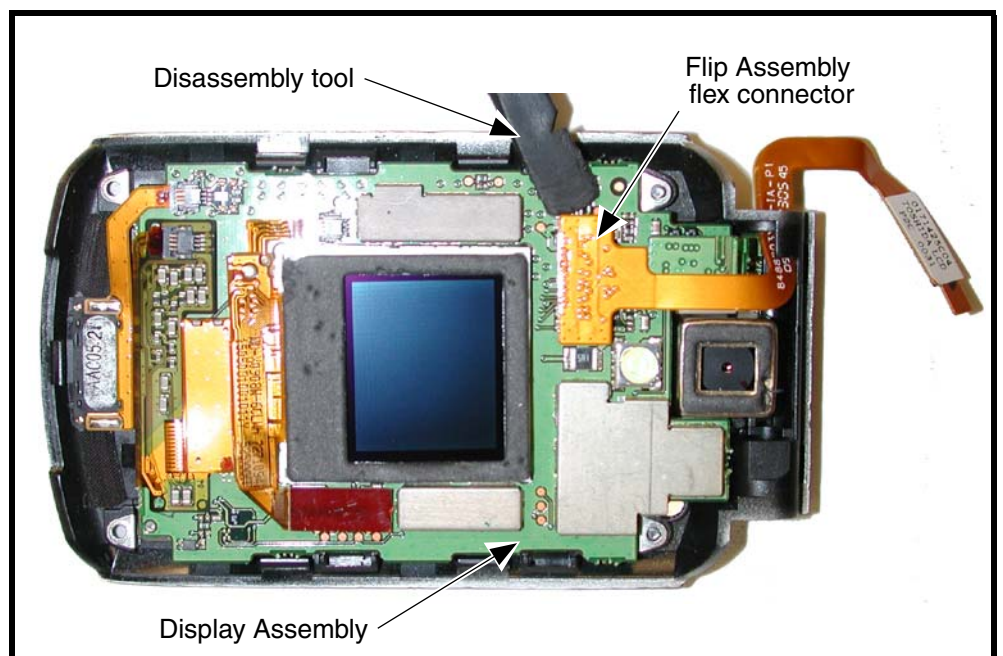

Figure 20. Removing the Flip Assembly Flex Connector

3. Move the flex connector away from the display assembly.

4. Use the disassembly tool to unseat the camera assembly flex connector from the display module assembly (see Figure 21).

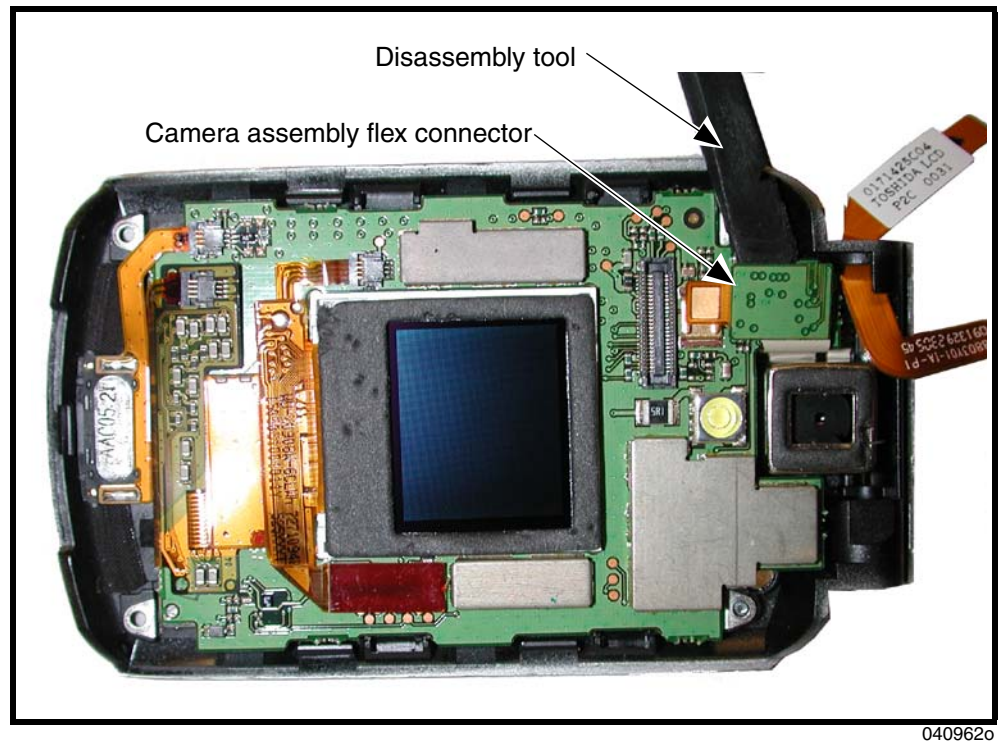

Figure 21. Removing the Camera Assembly Flex Connector



The FPC (flex) is easily damaged. Exercise extreme care when handling.

5. Use the pointed end of the disassembly tool to lift zero insertion force (ZIF) latch that unlocks the ZIF connector socket (see Figure 22).

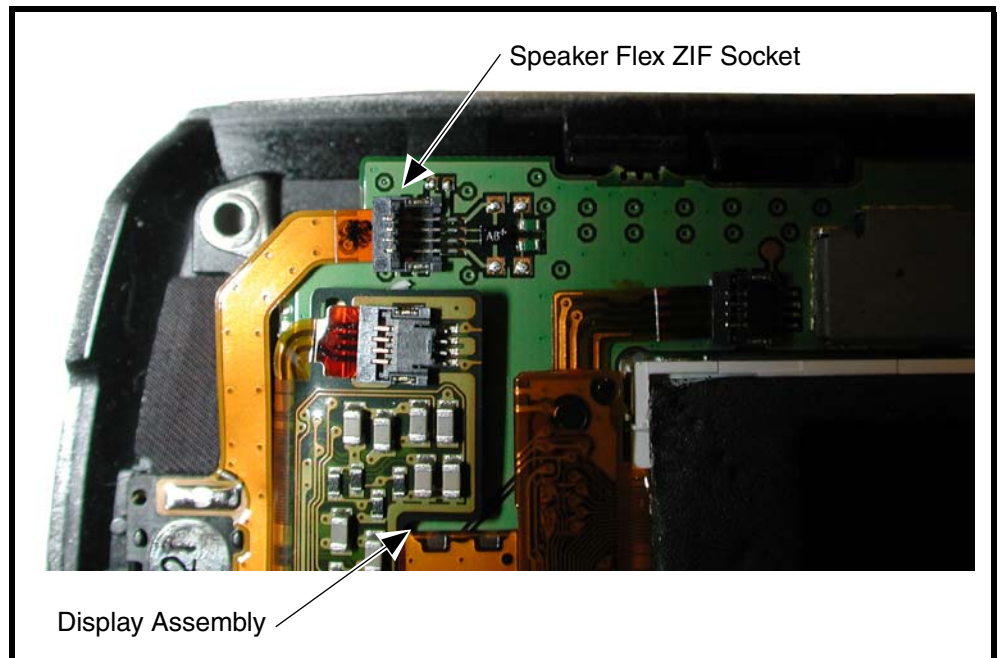

Figure 22. Removing the Display Assembly Flex Connector

6. Carefully disconnect the flex connector from the ZIF socket.
7. Carefully lift the display assembly out of the flip assembly (see Figure 23).

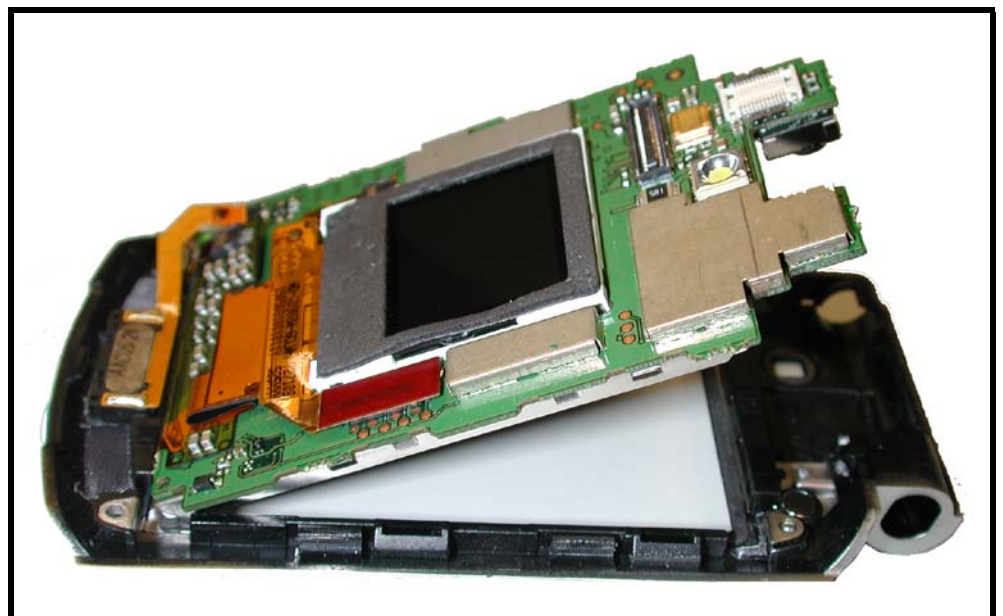

Figure 23. Removing the Display Assembly

-
8. To replace, align the display assembly to the flip housing.



The FPC (flex) is easily damaged. Exercise extreme care when handling.

9. Lower the display assembly onto the flip housing.
10. Insert the speaker flex ZIF connector into the ZIF socket. Lock the ZIF connector with the pointed end of the disassembly tool.
11. Carefully press the camera connector into its socket on the display assembly.
12. Carefully seat the display flex connector to the socket on the flip assembly.
13. Carefully align the flip flex assembly connector and seat it in its socket on the display assembly.
14. Carefully lower the display assembly onto the flip assembly. Be careful not to damage the display flex or flex connector while reassembling the display lens assembly.
15. Replace the flip assembly cover, flip assembly, keypad assembly, transceiver board, rear housing, antenna, SIM, battery, and battery cover as described in the procedures.

Subscriber Identity Module (SIM) and Identification

SIM Card

A SIM is required to access the existing local GSM network, or remote networks when traveling (if a roaming agreement has been made with the provider).

The SIM contains:

- All the data necessary to access GSM services
- The ability to store user information such as phone numbers
- All information required by the network provider to provide access to the network

Personality Transfer

A personality transfer is required when a phone is express exchanged or when the main board is replaced. Personality transfers reproduce the customer's personalized details such as menu, and stored memory, such as phonebooks, or program the customer's phone with basic user information such as language selection. V3x telephones use mobile PhoneTools® synchronization software to effect a personality transfer.

Identification

Each Motorola GSM phone is labeled with a several identifying numbers. The following section describes the current identifying labels.

Mechanical Serial Number (MSN)

The Mechanical Serial Number (MSN) is an individual unit identity number and remains with the unit throughout its life.

The MSN can be used to log and track a phone on Motorola's Service Center Database.

The MSN is divided into 4 sections as shown in Figure 24.

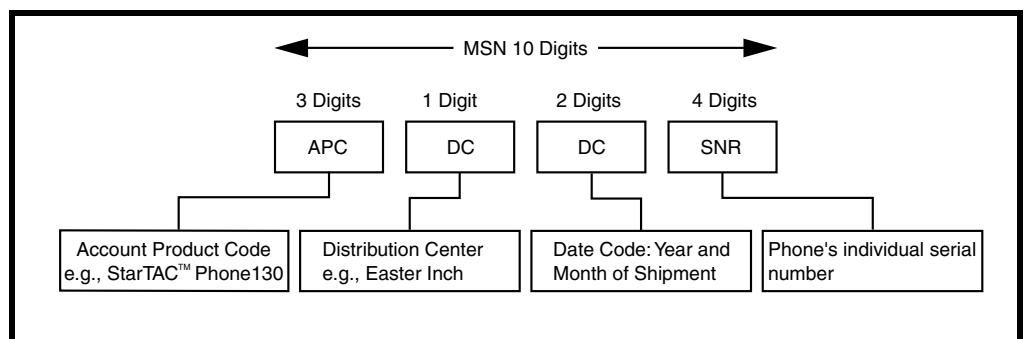

000807b

Figure 24. MSN Label Breakdown

International Mobile Station Equipment Identity (IMEI)

The International Mobile station Equipment Identity (IMEI) number is an individual number unique to the PCB and stored within the phone's memory.

The IMEI uniquely identifies an individual mobile station provides a way to control access to GSM networks based on mobile station types or individual phones. The full IMEI structure is listed in Table 2.

Table 2. IMEI Number Breakdown

TAC	Serial Number	Check Digit
NNXXXXXX	ZZZZZZ	A

Where:

TAC Type Allocation Code, formerly known as Type Approval Code

NN Reporting body identifier

XXXXXX Type identifier

ZZZZZZ Individual unit serial number

A Phase 1 = 0.

Phase 2 = check digit defined as a function of all other IMEI digits

Other label number configurations present are:

- **TRANSCIVER NUMBER:** Identifies the product type, usually the SWF number. (for example, V100).
- **PACKAGE NUMBER:** Identifies the equipment type, mode, and language in which the product is shipped.

Troubleshooting

Table 3. Level 1 and 2 Troubleshooting Chart

SYMPTOM	PROBABLE CAUSE	VERIFICATION AND REMEDY
1. Telephone will not turn on or stay on.	a) Battery either discharged or defective.	Measure battery voltage across a 50 ohm (>1 Watt) load. If the battery voltage is <3.25 Vdc, recharge the battery using the appropriate battery charger. If the battery will not recharge, replace the battery. If battery is not at fault, proceed to b.
	b) Battery connectors open or misaligned.	Visually inspect the battery connectors on both the battery and the telephone. Realign and, if necessary, either replace the battery or refer to a Level 3 Service Center for battery connector replacement. If battery connectors are not at fault, proceed to c.
	c) Transceiver board assembly defective.	Remove the transceiver board assembly. Substitute a known good assembly and temporarily reassemble. Press and hold the PWR button; if the phone turns on and stays on, disconnect the dc power source and reassemble with the new transceiver board assembly. Verify that the fault has been cleared. If the fault has not been cleared then proceed to d.
	d) keyboard assembly failure.	Replace the keyboard assembly. Temporarily connect a +3.6 Vdc supply to the battery connectors. Press and hold the PWR button. If the phone turns on and stays on, disconnect the dc power source and reassemble with the new keyboard assembly.
2. Telephone exhibits poor reception or erratic operation such as calls frequently dropping or weak or distorted audio.	a) Antenna assembly defective.	Check to make sure that the antenna pin is properly connected to the transceiver board assembly. If connected properly, substitute a known good antenna. If the fault is still present, proceed to b.
	b) Transceiver board assembly defective.	Replace the transceiver board assembly (refer to 1c). Verify that the fault has been cleared and reassemble the unit with the new transceiver board assembly.
3. Display is erratic, or provides partial or no display.	a) Transceiver board connections faulty.	Remove rear chassis assembly from the phone, check general condition of FPC (flex). If the flex is good, check that the flex connector is fully pressed down. If not, check connector to transceiver board connections. If faulty connector, replace the transceiver board assembly. If connector is not at fault, proceed to b.
	b) Flip assembly defective.	Temporarily replace the flip assembly with a known good assembly. If fault has been cleared, reassemble with the new flip assembly. If fault not cleared, proceed to c.
	c) Transceiver board assembly defective.	Replace the transceiver board assembly (refer to 1c). Verify that the fault has been cleared and reassemble the unit with the new transceiver board assembly.
4. Incoming call alert transducer audio distorted or volume is too low.	Faulty transceiver board assembly.	Replace the transceiver board assembly (refer to 1c). Verify that the fault has been cleared and reassemble with the new transceiver board assembly.

Table 3. Level 1 and 2 Troubleshooting Chart (Continued)

SYMPTOM	PROBABLE CAUSE	VERIFICATION AND REMEDY
5. Telephone transmit audio is weak (usually indicated by called parties complaining of difficulty in hearing voice).	a) Microphone connections to the transceiver board assembly defective.	Gain access to the microphone as described in the procedures. Check connections. If connector is faulty proceed to c; if the connector is not at fault, proceed to b.
	b) Microphone defective.	Gain access to microphone. Disconnect and substitute a known good microphone. Place a call and verify improvement in transmit signal as heard by called party. If good, reassemble with new microphone. If microphone is not at fault, reinstall original microphone and proceed to c.
	c) Transceiver board assembly defective.	Replace the transceiver board assembly (refer to 1c). Verify that the fault has been cleared and reassemble with the new transceiver board assembly.
6. Receive audio from earpiece speaker is weak or distorted.	a) Connections to or from transceiver board assembly defective.	Gain access to the transceiver board assembly as described in the procedures. Check flex and the flex connector from the flip assembly to the transceiver board assembly. If flex is at fault, replace flip assembly. If flex connector is at fault, proceed to d. If connection is not at fault, proceed to b.
	b) Flip assembly defective.	Temporarily replace the flip assembly with a known good assembly. If fault has been cleared, reassemble with the new flip assembly. If fault not cleared, proceed to c.
	c) Antenna assembly defective.	Check that the antenna is installed correctly. If the antenna is installed correctly, substitute a known good antenna assembly. If this does not clear the fault, reinstall the original antenna assembly and proceed to d.
	d) Transceiver board assembly defective.	Replace the transceiver board assembly (refer to 1c). Verify that the fault has been cleared and reassemble with the new transceiver board assembly.
7. Telephone will not recognize or accept SIM.	a) SIM defective.	Check the SIM contacts for dirt. Clean if necessary and check if fault has been cleared. If the contacts are clean, insert a known good SIM into the telephone. Power up the phone and confirm that the SIM has been accepted. If the fault no longer exists, replace the defective SIM. If the SIM is not at fault, proceed to b.
	b) Flip assembly defective.	Temporarily replace the flip assembly with a known good assembly. If fault has been cleared, reassemble with the new flip assembly. If fault not cleared, proceed to c.
	c) Transceiver board assembly defective.	Replace the transceiver board assembly (refer to 1c). Verify that the fault has been cleared and reassemble with the new transceiver board assembly.
8. Phone does not sense when flip is opened or closed (usually indicated by inability to answer incoming calls by opening the flip, or inability to make outgoing calls).	a) Flip assembly defective.	Temporarily replace the flip assembly with a known good assembly. If fault has been cleared, reassemble with the new flip assembly. If fault not cleared, proceed to b.
	b) Transceiver board assembly defective.	Replace the transceiver board assembly (refer to 1c). Verify that the fault has been cleared and reassemble with the new transceiver board assembly.

Table 3. Level 1 and 2 Troubleshooting Chart (Continued)

SYMPTOM	PROBABLE CAUSE	VERIFICATION AND REMEDY
9. Vibrator feature not functioning.	Transceiver board assembly defective.	Replace the transceiver board assembly (refer to 1c). Verify that the fault has been cleared and reassemble with the new transceiver board assembly.
10. Internal Charger not working.	Faulty charger circuit on transceiver board assembly.	Test a selection of batteries in the rear pocket of the desktop charger. Check LED display for the charging indications. If the batteries charge properly, then the internal charger is at fault. Replace the transceiver board assembly (refer to 1c). Verify that the fault has been cleared and reassemble with the new transceiver board assembly.
11. Real Time Clock resetting when standard battery is removed.	Lithium button cell in the display board may be depleted.	Refer service to a Level 3 service center for replacement.
12. No or weak audio when using headset.	a) Headset plug not fully pushed into the jack socket.	Ensure the headset plug is fully seated in the jack socket. If fault not cleared, proceed to b.
	b) Faulty jack socket on transceiver board assembly.	Replace the transceiver board assembly (refer to 1c). Verify that the fault has been cleared and reassemble with the new transceiver board assembly.

Programming: Software Upgrade and Flexing

Contact your local technical support engineer for information about equipment and procedures for flashing and flexing.

Part Numbers

The following charts are provided as a reference for the parts associated with V3x telephones.

Related Publications

Motorola V3x User's Guide, English

68XXXXXX108

Exploded View Diagram

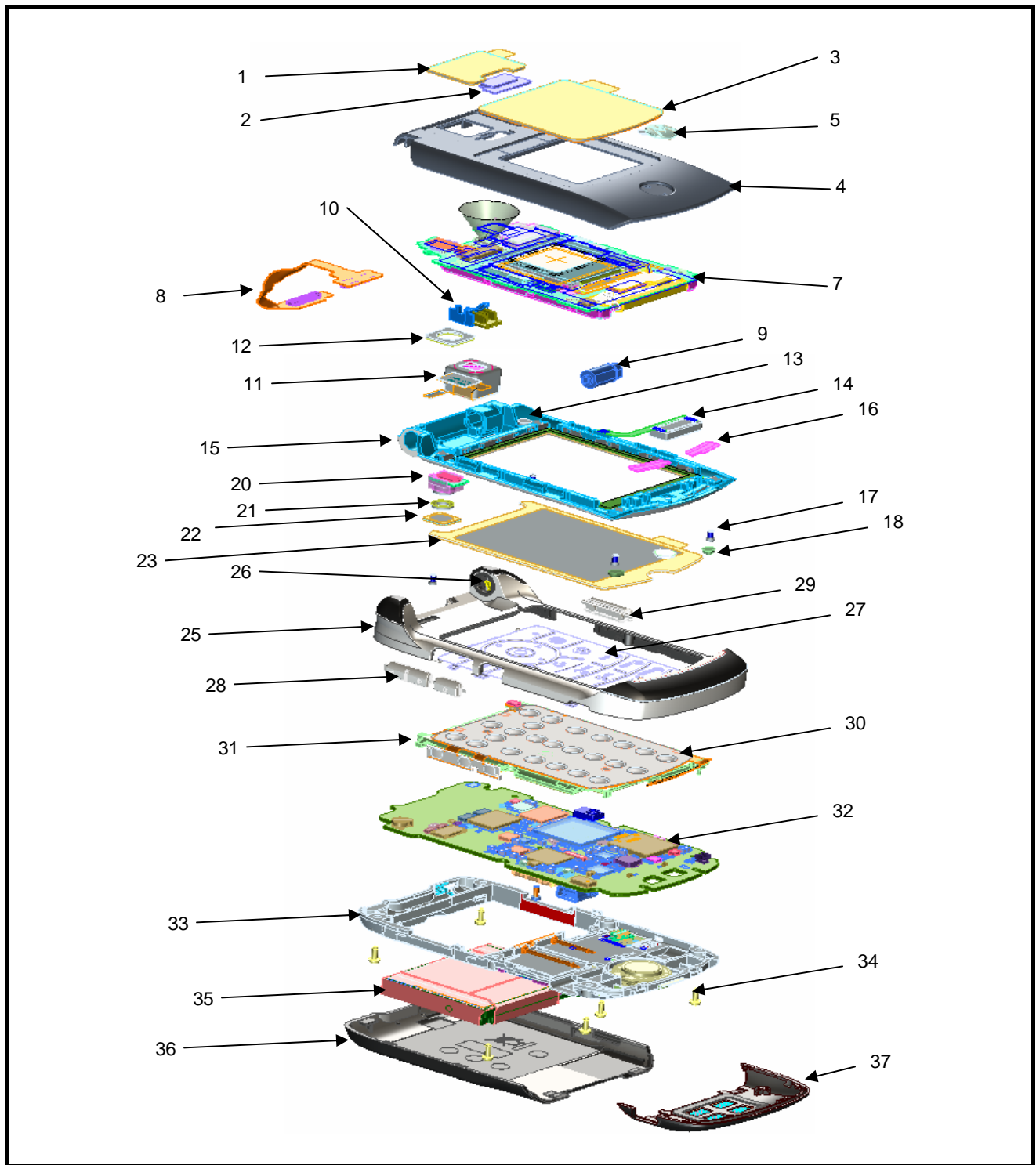

Figure 25. Exploded View Diagram

040967o

Exploded View Parts List

Table 4. Exploded View Parts List

Item Number	Part Number	Description
1	6171885B01	LENS, 2MP
2	4885102C24	FLASH, CAMERA
3	6188777Y01	LENS, CLI
4	0171425C01	HOUSING, FLIP OUTER
5	3371139D01	ESCUTCHEON, FLIP
6	1171902B01	GASKET, CLI
7	0171102C01	MODULE, DISPLAY
8	0171456C01	FLEX, HINGE
9	5571967B01	CAM, HINGE
10	3871407C01	ADJUST, MACRO
11	0171347C01	MODULE, 2MP
12	3271688B01	GASKET, 2MP
13	5988515L01	MAGNET
14	0171325C01	SPEAKER, EARPIECE ASSY
15	0188755Y01	HOUSING, FLIP INNER
16	1371698B01	MESH, ACOUSTIC
17	0387726M02	SCREW, FLIP (4X)
18	3271689B02 3271689B01	BUMPER, FLIP (left) Bumper, flip (right)
19	3371697B02	ESCUTCHEON, EARPIECE

Item Number	Part Number	Description
20	0171343C01	MODULE, VGA
21	3271688B02	GASKET, VGA
22	6171865B01	LENS, VGA
23	6188778Y01	LENS, MAIN DISPLAY
24	0387726M02	SCREW, FLIP
25	0188747Y01	HOUSING, BASE INNER ASSY
26	3971966B01	CONTACT, KNUCKLE
27	3888722Y01	KEYPAD, MAIN
28	3871943B01	BUTTONS, SIDE, UP / DN / SMART
29	3871942B01	BUTTONS, SIDE, CAM / VA
30	0171646C01	FLEX, POPPLE DOME / EL
31	0171107C01	SHIELD, SPACER ASSY
32	SLG4932AA	PCB, TRANSCEIVER, ASSY
33	0188746Y01	HOUSING, BASE OUTER ASSY
34	0387791L07	SCREW, BASE (6X)
35	SNN5781A	BATTERY, MAIN, SC5
36	1571931B01	COVER, BATTERY SC5
37	1571951B01	HOUSING, LOWER ANTENNA CAP



There is a danger of explosion if the Lithium Ion battery pack is replaced incorrectly. Replace only with the same type of battery or equivalent as recommended by the battery manufacturer. Dispose of used batteries according to the manufacturer's instructions.

To order parts use the following Link:

https://wissc.motorola.com/wissc_root/main/BrowserOK.html

(Password is Required)

For information on ordering parts contact EMEA at +49 461 803 1404.

A

alert settings 15
antenna cap, removing and replacing 21
antenna, removing and replacing 27

B

battery
 function 15
 gauge 15
 removing 18
battery cover
 removing 18

C

caller ID 13
Canadian Interference-Causing Equipment regulations 5
changes
 product 5
conventions 7
copyrights
 computer software 6

D

disassembly 18
display 14

E

exploded view diagram 45
exploded view parts list 46

F

FCC rules 5
features
 caller ID 13
 SIM Toolkit 12
 text entry 13
 Wireless Access Protocol (WAP) 12
features, product 11
flip assembly, removing and replacing 31
flip cover, removing and replacing 32
flip display assembly, removing and replacing 35

I

identification 39
 international mobile station equipment identity 40
 mechanical serial number 39
 product 5

IMEI 40

indicators
 service indicator (status light) 14
Introduction 5

L

liquid crystal display (LCD) 14

M

MSN 39

N

names
 product 5

O

operation
 controls, indicators, and I/O 14
operation, general 14
overview, product 11

P

parts 44
 exploded view diagram 45
 exploded view parts list 46
product
 changes 5
 identification 5
 names 5
publications, related 44

R

rear housing
 removing 22
regulatory agency compliance 5
related publications 44
removing
 antenna 27
 antenna cap 21
 battery 15, 18
 battery cover 18
 flip assembly 31
 flip cover 32
 flip display assembly 35
 rear housing 22
 SIM 20
 transceiver board assembly 23

- volume/smart buttons 29
- replacement parts
 - contact information 8
- replacing
 - antenna 27
 - antenna cap 21
 - battery 18
 - flip assembly 31
 - flip cover 32
 - flip display assembly 35
 - rear housing 22
 - SIM 20
 - transceiver board assembly 23
 - volume/smart buttons 29

S

- serial number
 - mechanical 39
- service manual
 - about 6
 - revisions 7
 - scope 6
- service policy 7
 - customer support 7
 - out of box failure 7
 - product support 7
- service procedure
 - ordering replacement parts 8
- shut down
 - upon battery removal 15
- SIM Application Toolkit 12
- SIM card 39
 - personality transfer 39
 - replacing 20
- SIM, removing and replacing 20
- specifications 9
- support
 - customer 7
 - product 7

T

- text entry 13
- tools and test equipment 17
- transceiver board assembly, removing and replacing 23
- troubleshooting 41

V

- volume/smart buttons, removing and replacing 29

W

- warranty service 7
- wireless access protocol (WAP) 12

MOTOROLA and the Stylized M Logo are registered in the US Patent & Trademark Office.
The Bluetooth trademarks are owned by their proprietor and used by Motorola, Inc. under license.
All other product or service names are the property of their respective owners.® Reg. U.S. Pat. & Tm. Off.

© 2005 Motorola, Inc.
All rights reserved.
Mobile Devices Business,
Sawgrass International Concourse
789 International Parkway, Mailstop S2C
Sunrise, FL 33325-6222

6809497A15-O