

RX MID CHANNELS
 850: CH190 -- 881,6
 GSM: CH 62 -- 942,4MHz
 EGSM: CH 37 -- 942,4MHz
 DCS: CH 700 -- 1842,8MHz
 PCS: CH 661 -- 1960MHz

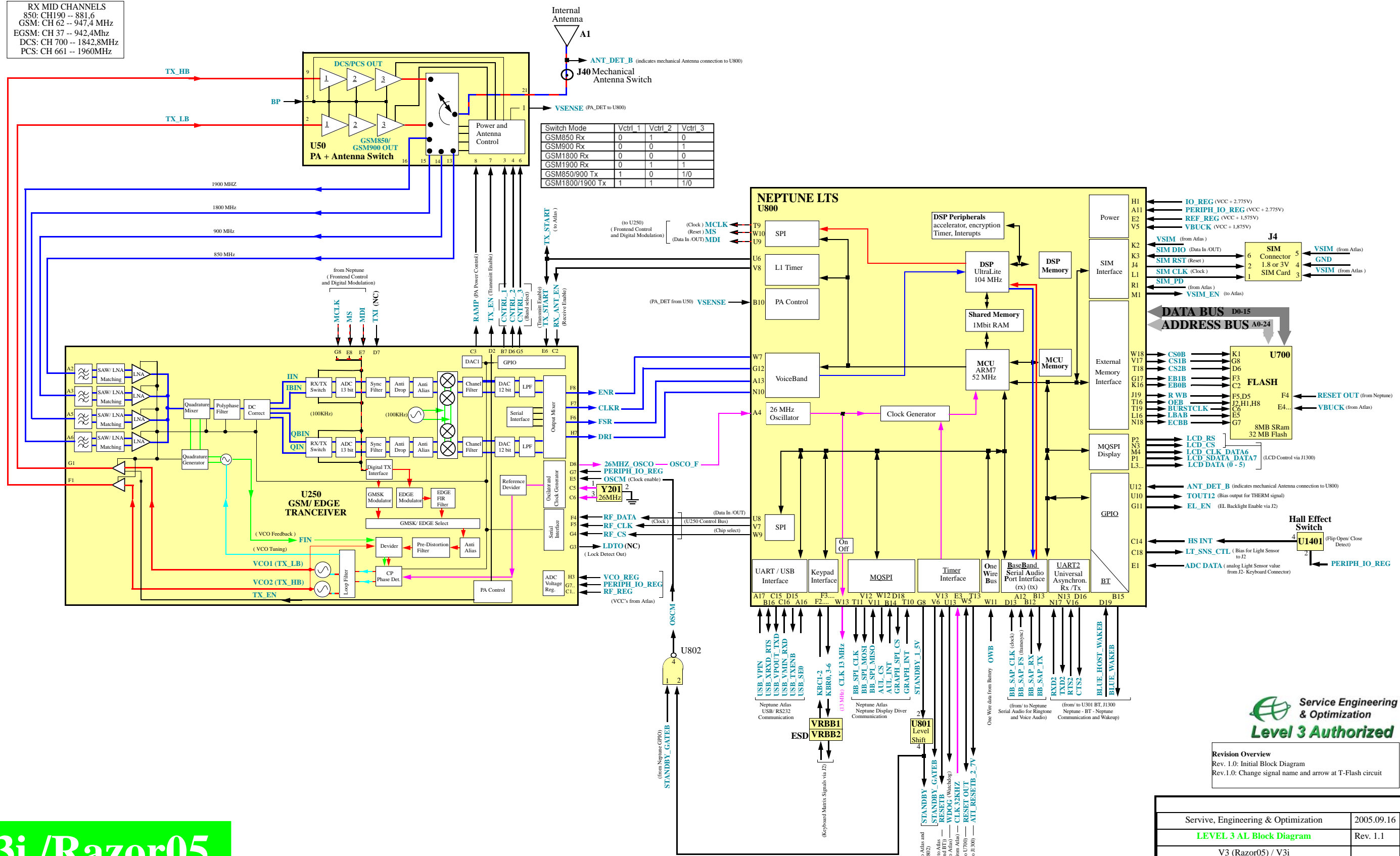

Service Engineering & Optimization
Level 3 Authorized

Revision Overview
 Rev. 1.0: Initial Block Diagram
 Rev.1.0: Change signal name and arrow at T-Flash circuit

Service, Engineering & Optimization	2005.09.16
LEVEL 3 AL Block Diagram	Rev. 1.1
V3i (Razor05) / V3i	
Alexander Buehler, Michael Mauderer	Page 1 of 2

V3i /Razor05

V3i /Razor05

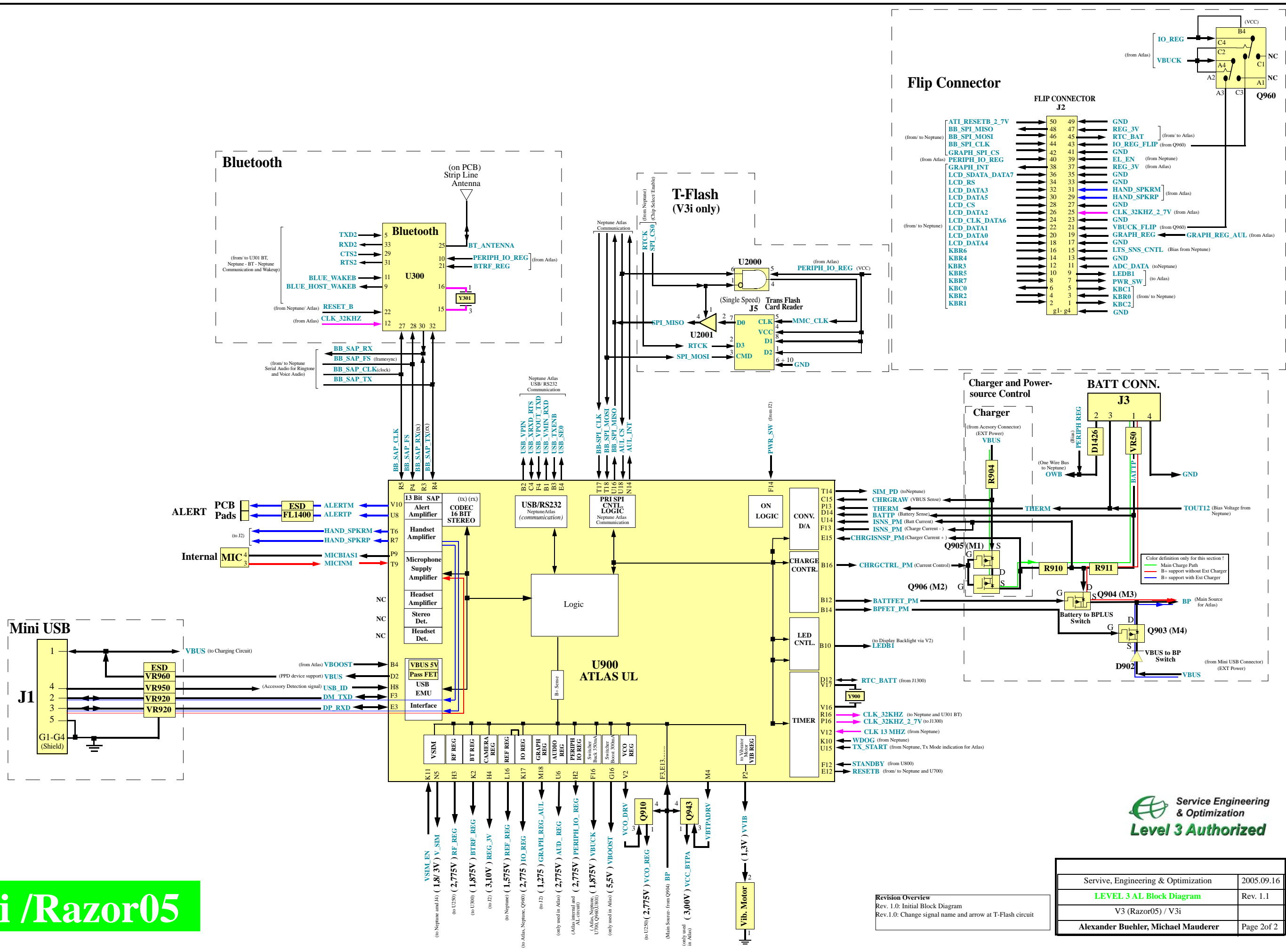

Flip Connector

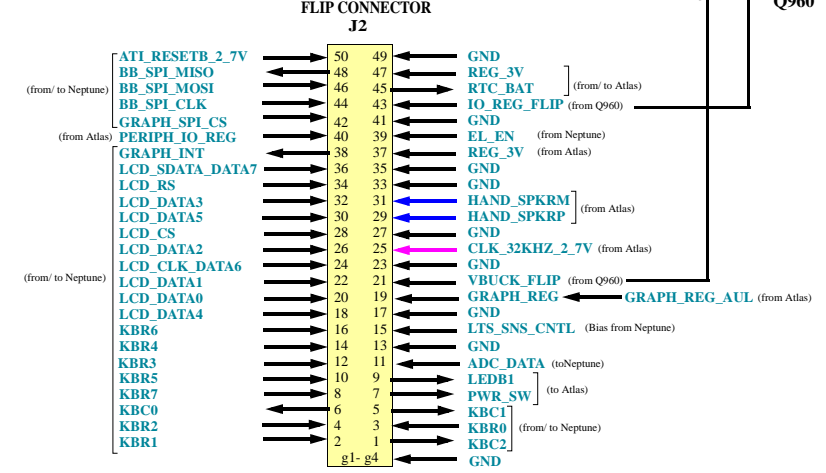

Bluetooth

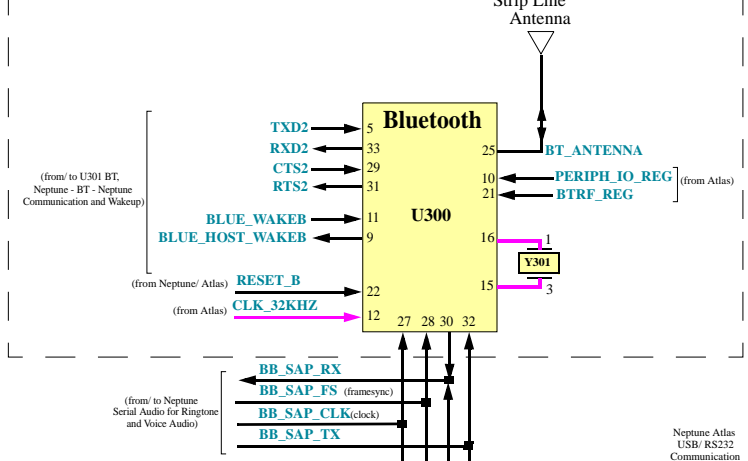

T-Flash (V3i only)

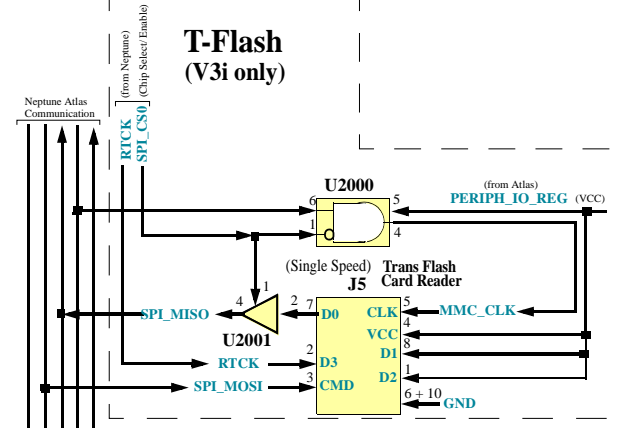

Charger and Power-source Control

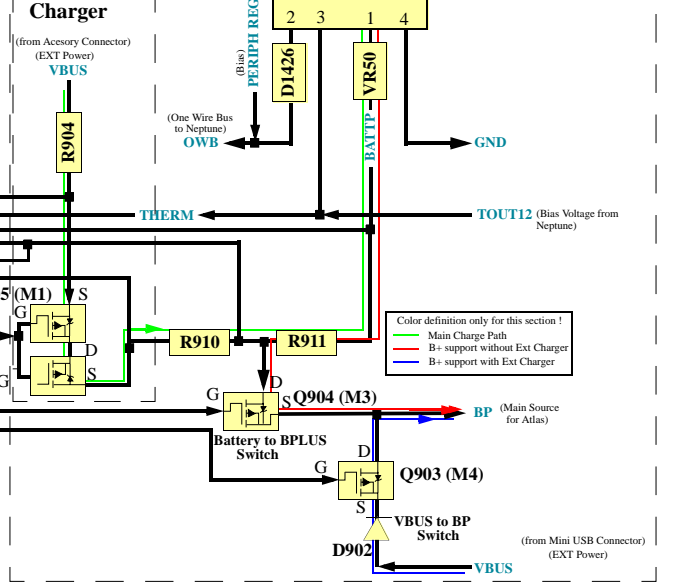

Mini USB

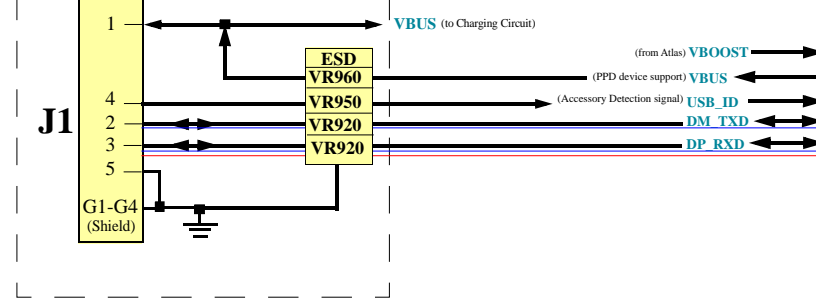

Service Engineering & Optimization
Level 3 Authorized

Revision Overview
Rev. 1.0: Initial Block Diagram
Rev. 1.0: Change signal name and arrow at T-Flash circuit

Servive, Engineering & Optimization	2005.09.16
LEVEL 3 AL Block Diagram	Rev. 1.1
V3 (Razor05) / V3i	
Alexander Buehler, Michael Mauderer	Page 2of 2