



MOTOROLA

Level 1 and 2 Service Manual

6809509A88-O

MOTOKRZR™ K3

Wireless Telephone



UMTS 2100, GSM 900/1800/1900 GPRS

MOTOROLA and the Stylized M Logo are registered in the US Patent & Trademark Office.
All other product or service names are the property of their respective owners.

The Bluetooth trademarks are owned by their proprietor and used by Motorola, Inc. under license.
© Motorola, Inc. 2007.
All rights reserved.

Mobile Devices Business,
Sawgrass International Concourse
789 International Parkway
Room S2C
Sunrise, FL 33325-6220

Contents

Introduction	5
Product Identification	5
Product Names	5
Product Changes	5
Regulatory Agency Compliance	5
Computer Program Copyrights	6
About This Service Manual	6
Warranty Service Policy	7
Parts Replacement	8
Product Overview	11
Features	11
General Operation	14
Controls, Indicators, and Input / Output (I/O) Connections	14
Alert Settings	16
Battery Function	16
Operation	17
Tools and Test Equipment	19
Disassembly	20
Removing and Replacing the Battery Door and Battery	20
Removing and Replacing the Trans Flash Memory Module	22
Removing and Replacing the Subscriber Identity Module (SIM)	23
Removing and Replacing the Rear Housing	24
Removing and Replacing the Transceiver Board Assembly	26
Removing and Replacing the Daughter Board Assembly	28
Removing and Replacing the Keypad	29
Removing and Replacing the Antenna Assembly	30
Removing and Replacing the Keypad Mylar	32
Removing and Replacing the Flip Assembly Cover	36
Removing and Replacing the Display Module Assembly	38
Removing and Replacing the VGA Camera Assembly	40
Removing and Replacing the Main Camera Assembly	41
Removing and Replacing the Flip Hinge and Flex Assembly	42
Replacing the CLI and Main Display Lens	49
Subscriber Identity Module (SIM) and Identification	52
USIM Card	52
Personality Transfer	52
Identification	52
Troubleshooting	54
Manual Test Mode	54
Manual Test Mode Commands	55
Troubleshooting Chart	57
Programming: Software Upgrade and Flexing	58
Part Numbers	58
Exploded View Diagram	59
Exploded View Parts List	60
Accessories	60

Introduction

Motorola® Inc. maintains a worldwide organization that is dedicated to provide responsive, full-service customer support. Motorola products are serviced by an international network of company-operated product-care centers as well as authorized independent service firms.

Available on a contract basis, Motorola Inc. offers comprehensive maintenance and installation programs that allow customers to meet requirements for reliable, continuous communications.

To learn more about the wide range of Motorola service programs, contact your local Motorola products representative or the nearest Customer Service Manager.

Product Identification

Motorola products are identified by the model number on a label usually located under the battery. Use the entire model number when inquiring about the product. Numbers are also assigned to chassis and kits. Use these numbers when requesting information or ordering replacement parts.

Product Names

Product names are listed on the front cover. Product names are subject to change without notice. Some product names, as well as some frequency bands, are available only in certain markets.

Product Changes

When electrical, mechanical or production changes are incorporated into Motorola products, a revision letter is assigned to the chassis or kit affected, for example; -A, -B, or -C, and so on.

The chassis or kit number, complete with revision number, is imprinted during production. The revision letter is an integral part of the chassis or kit number and is also listed on schematic diagrams and printed-circuit board layouts.

Regulatory Agency Compliance

This device complies with Part 15 of the FCC Rules. Operation is subject to the following conditions:

- This device may not cause any harmful interference
- This device must accept interference received, including interference that may cause undesired operation

This class B device also complies with all requirements of the Canadian Interference-Causing Equipment Regulations (ICES-003).

Cet appareil numérique de la classe B respecte toutes les exigences du Règlement sur le matériel brouilleur du Canada.

Computer Program Copyrights

The Motorola products described in this manual may include Motorola computer programs stored in semiconductor memories or other media that are copyrighted with all rights reserved worldwide to Motorola. Laws in the United States and other countries preserve for Motorola, Inc. certain exclusive rights to the copyrighted computer programs, including the exclusive right to copy, reproduce, modify, decompile, disassemble, and reverse-engineer the Motorola computer programs in any manner or form without Motorola's prior written consent. Furthermore, the purchase of Motorola products shall not be deemed to grant either directly or by implication, estoppel, or otherwise, any license or rights under the copyrights, patents, or patent applications of Motorola, except for a nonexclusive license to use the Motorola product and the Motorola computer programs with the Motorola product.

About This Service Manual

Use of this manual assures proper installation, operation, and maintenance of Motorola products and equipment. It contains all service information required for the equipment described and is current as of the printing date. Refer questions about this manual to the nearest Customer Service Manager.

Audience

This manual aids service personnel in testing and repairing K3 telephones. Service personnel should be familiar with electronic assembly, testing, and troubleshooting methods, and with the operation and use of associated test equipment.

Scope

This manual provides basic information relating to K3 telephones, and also provides procedures and processes for repairing the phones at Level 1 and 2 service centers including:

- Unit swap out
- Repairing of mechanical faults
- Basic modular troubleshooting
- Testing and verification of unit functionality
- Initiate warranty claims and send faulty modules to Level 3 or 4 repair centers

Conventions

The following special characters and typefaces, are used in this manual to emphasize certain types of information.



Note: Emphasizes additional information pertinent to the subject matter.



Caution: Emphasizes information about actions which may result in equipment damage.



Warning: Emphasizes information about actions which may result in personal injury.



Keys to be pressed are represented graphically. For example, instead of “Press the End key”, you will see “Press ”.

Information from a screen is shown in text as similar as possible to what displays on the screen. For example, **PHONEBOOK**.

Information that you need to type is printed in **boldface type**.

Warranty Service Policy

The product is sold with the standard 12-month warranty terms and conditions. Accidental damage, misuse, and extended warranties offered by retailers are not supported under warranty. Non-warranty repairs are available at agreed fixed repair prices.

Out-of-Box Failure Policy

The standard out-of-box failure criteria applies. Return customer units that fail very early on after the date of sale to Manufacturing for root cause analysis, to guard against epidemic criteria. Manufacturing to bear the costs of early life failure.

Product Support

Customer's original units will be repaired but not refurbished as standard. Appointed Motorola Service Hubs will perform warranty and non-warranty field service for level 2 (assemblies) and level 3 (limited PCB component). Motorola High Tech Centers will perform level-4 (full component) repairs.

Customer Support

Customer support is available through dedicated Call Centers and in-country help desks. Product Service training is available through the local Motorola Support Center.

Parts Replacement

When ordering replacement parts or equipment, include the Motorola part number and description used in the service manual.

When the Motorola part number of a component is not known, use the product model number or other related major assembly along with a description of the related major assembly and of the component in question.

In the U.S.A., to contact Motorola, Inc. on your TTY, call: 800-793-7834.

Replacement Parts Service Division (RPSD)

Order replacement parts, test equipment, and manuals from RPSD.

U.S.A.

Phone: 800-422-4210

FAX: 800-622-6210

Website: <http://businessonline.motorola.com>

Outside U.S.A.

Phone: 847-538-8023

FAX: 847-576-3023

EMEA

Phone: +49 461 803 1404

Website: <http://emeaonline.motorola.com>

Asia

Phone: +65 648 62995

Website: <http://asiaonline.motorola.com>

Specifications

Table 1. Specifications

Function	Specification
Frequency Range EGSM	TX: 880 - 915 MHz Frequency (MHz) = $890 + (0.2 \times n)$ where: $0 \leq n \leq 124$ Frequency (MHz) = $890 + (0.2 \times (n - 1024))$ where: $955 \leq n \leq 1023$ RX: 925 - 960 MHz Frequency (MHz) = $935 + (0.2 \times n)$ where: $0 \leq n \leq 124$ Frequency (MHz) = $935 + (0.2 \times (n - 1024))$ where: $955 \leq n \leq 1023$
Frequency Range DCS	TX: 1710 to 1785 MHz Frequency (MHz) = $1710.2 + (0.2 \times (n - 512))$ where: $512 \leq n \leq 885$ RX: 1805.2 to 1879.8 MHz Frequency (MHz) = $1805.2 + (0.2 \times (n - 512))$ where: $512 \leq n \leq 885$
Frequency Range PCS	TX: 1850 to 1910 MHz Frequency (MHz) = $1850.2 + (0.2 \times (n - 512))$ where: $512 \leq n \leq 810$ RX: 1930 to 1990 MHz Frequency (MHz) = $1930.2 + (0.2 \times (n - 512))$ where: $512 \leq n \leq 810$
Frequency Range UMTS	TX: 1920 to 1980 MHz Frequency (MHz) = $\text{UARFCN}^1 + 5$, where: $9612 \leq \text{UARFCN}^1 \leq 9888$ UARFCN ¹ in increments of 25 RX: 2110 to 2170 MHz Frequency (MHz) = $\text{UARFCN}^1 + 5$, where: $10562 \leq \text{UARFCN}^1 \leq 10838$ UARFCN ¹ in increments of 25
Channel Spacing	200 kHz (GSM, DCS, PCS), 5 MHz UMTS
Channels	174 EGSM, 374 DCS, 274 PCS carriers with 8 channels per carrier, 11 UMTS
Duplex Spacing	45 MHz GSM, 95 MHz DCS, 80 MHz PCS, 190 MHz UMTS
Modulation	GMSK AT BT = 0.3 (GSM, DCS, PCS), QPSK (UMTS)
Transmitter Phase Accuracy	5 degrees RMS, 20 Degrees peak
Frequency Error	± 0.1 ppm
Input/Output Impedance	50 ohms (nominal)
Nominal Operating Voltage	3.6 Vdc $\pm 10\%$ (battery) +4.4 Vdc $\pm 10\%$ (external connector)
Dimensions (xyz)	103.2 x 42.3 x 16.3mm
Size	63cc
Weight	105 g
Display	Main Display: 262K color QVGA, 320 x 240, 2.0" CLI Display: 262K color TFT, 120 x 160, 1.3"
Battery Life (950mAh) ²	GSM: Talk time: Up to 237minutes GSM: Standby time: Up to 452 hours WCDMA Talk time: Up to 196 minutes WCDMA Standby time: Up to 365 hours WCDMA Video talk time: Up to 135 minutes
Nominal Operating Temperature Range	-10° C to +55° C

GSM System Functions	Specification
Speech Coding Type	Regular Pulse excitation / linear predictive coding with long term prediction (RPE LPC with LTP)
Bit Rate	13.0 kbps
RF Power Output	32 dBm nominal GSM, 28.5 dBm nominal DCS / PCS
Spurious Emissions	-36 dBm from 0.1 to 1 GHz, -30 dBm from 1 to 4 GHz
Receive Sensitivity	-102 dBm GSM, -102 dBm DCS / PCS
RX Bit Error Rate	< 2%

UMTS System Functions	Specification
Speech Coding Type	Adaptive Multirate (AMR)
RF Power Output	21 dBm
Spurious Emissions	-36 dBm from 0.1 to 1 GHz, -30 dBm from 1 to 4 GHz
Error Vector Magnitude	< 17.5%
PN9 Bit Error Rate (VER)	0.1% @ 12.2K, -106.7 dBm
ACLR	-33 dBm @ ±5 MHz, -43 dBm @ ±10 MHz

Product Overview

Motorola K3 telephones represent the thinnest and slenderest 3G features in a small and lightweight package. These Global System for Mobile communications (GSM) General Packet Radio Service (GPRS) Wireless Application Protocol (WAP) enabled mobile phones incorporate an icon based User Interface (UI) for easier operation, allows Short Message Service (SMS) text messaging, Multi-media Messaging Services (MMS), and includes Personal Information Manager (PIM) functionality.

MOTOKRZR K3™ is a multi-band phone that allows roaming within the GSM 900 MHz, 1800 MHz Digital Cellular System (DCS), and PCS 1900 MHz bands, in addition to the UMTS WCDMA 2100 MHz band.

K3 telephones have a clam form factor design. They feature an anodized aluminum housing and have an externally viewable 96x80 1.0" 65K CSTN external display for caller identification and date/time, an internal 176x220 1.9" 262K TFT display, and the speaker located in the flip. The bottom part of the clam (front housing) contains the keypad, transceiver printed circuit board (PCB), microphone, flex connection, external accessory connector, smart button, volume buttons, and voice button. The standard 750 mAh Lithium Ion (Li Ion) battery fits behind a removable back cover.

The phone accepts both 3V and 1.8V mini subscriber identity module (SIM) cards, which fit into the SIM holder next to the battery. The antenna is internal. Inexpensive direct connection to a computer or handheld device via USB or Bluetooth™ for data and fax calls, and for synchronizing phonebook entries with Mobile Phone Tools software, can be accomplished by using the optional data cable and soft modem.

Features

K3 telephones use advanced, self-contained, sealed, custom integrated circuits to perform the complex functions required for GSM GPRS communication. Aside from the space and weight advantage, microcircuits enhance basic reliability, simplify maintenance, and provide a wide variety of operational functions.

Features available in this family of telephones include:

- Ultra Slim form factor
- EDGE for high speed data access (class 12)
- Video Capture & Playback MPEG4 (15 fps CIF)
- Audio/Video streaming (3GPP)
- Video Progressive Download
- Dedicated Carrier Key
- Integrated Stereo Bluetooth Connectivity (Class 2)
- 2MP digital camera with 8x digital zoom
- MicroSD slot for upgradeable memory
- Push To Share (images, video, audio files)
- Dynamic Idle
- 22MB of embedded end user memory
- Rich, pre-loaded J2ME™ games, screen savers
- Downloadable themes, ringer tones, images, animations
- Image borders, text overlay, image editing
- Midi, MP3, AAC, AAC+ Enhanced, iTunes music player
- PIM functionality with Picture Caller ID
- Voice memo & enhanced predictive text

- Enhanced voice recognition
- Record up to 25 minutes of video on embedded memory
- Firmware Over-The Air (FOTA)
- UI Skinning
- Motosync – contacts (calendar, emails TBC)

Voice Commands and Voice Note Recording

Voice commands can be used for voice dialing phone numbers in the phone book and for creating voice shortcuts for menu items.

K3 telephones also include a voice recorder that allows up to 2 minutes of personal messages to be recorded. This feature has a complete set of record, playback, and management tools that make it easy to store and maintain a list of personal memos.

Wireless Access Protocol (WAP) 2.0 Compliancy

In the WAP environment, access to the Internet is initiated in wireless markup language (WML), which is derived from hypertext markup language (HTML). The request is passed to a WAP gateway which retrieves the information from the server in standard HTML (subsequently filtered to WML) or directly in WML if available. The information is then passed to the mobile subscriber via the mobile network.

The K3 microbrowser can be configured for baud, idle timeout, line type, phone number, and connection type.



Bitmap image data will download as text. If the image is larger than the screen, only part of the image will display.



When the user receives a call while in browser mode, the browser will pause and allow the user to resume after completing the call.

SIM Application Toolkit™ - Class 2

SIM Application Toolkit is a value-added service delivery mechanism that allows GSM operators to customize the services they offer their customers, from the occasional user who requests sports news and traffic alerts, to a high call time business user who receives stock alerts and checks flight times. Operators can now create their own value-added services menu quickly and easily in the phone. The customized menu will appear as the first menu and may be updated over-the-air with new services when customers request them.

Simplified Text Entry

There are three different ways to enter text using the phone keypad:

- iTAP™ predictive text entry. Press a key to generate a character and a dynamic dictionary uses this to build and display a set of word or name options. The iTAP™ feature may not be available on the phone in all languages.
- Tap. Press a key to generate a character.
- Numeric. The keypad produces numeric characters only. For some text areas this is the only method available; for example, phone numbers.

Caller Line Identification

Upon receipt of a call, the calling party's phone number is compared to the phone book. If the number matches a phone book entry, that name will be displayed. If there is no phone book entry, the incoming phone number will be displayed. In the event that no caller identification information is available, the Incoming Call message is displayed.



User must subscribe to a caller line identification service through their service provider.

Other Features

Detailed descriptions of these and other K3 features can be found in the appropriate user's guide listed in the "Related Publications" section toward the end of this manual.

General Operation

Controls, Indicators, and Input / Output (I/O) Connections

The K3 series telephone's controls are located on the sides of the flip and on the keypad. Indicators, in the form of icons, are displayed on the LCD (see Figure 2). K3 phones have an audible alert transducer on the top and I/O connectors, consisting of a charger/accessory port, located on the side of the phone. See Figure 1.

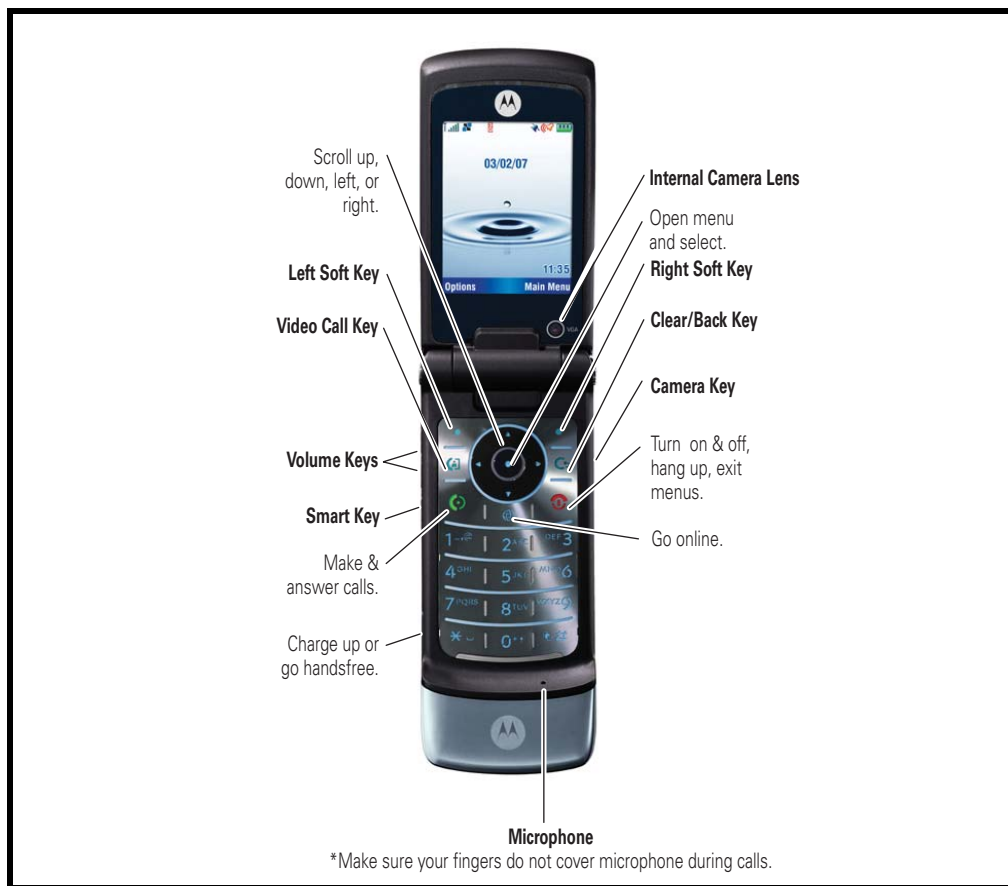

0625990

Figure 1. Controls, indicators, and I/O

“Soft keys” refer to non-labeled keys that correspond to text options displayed on the screen. The left and right soft keys perform the function shown in the corners of the display. The right key will usually select an option whereas the left key will usually exit a function or return to a previous screen.

The center select key opens the initial menu structure, or allows access to a submenu.

Color Display

The K3 wireless phones feature a 262K color QVGA 320 x240 pixel display.

Display animation makes the phone’s menus move smoothly as the user scrolls up and down. Figure 2 shows some common icons displayed on the LCD.

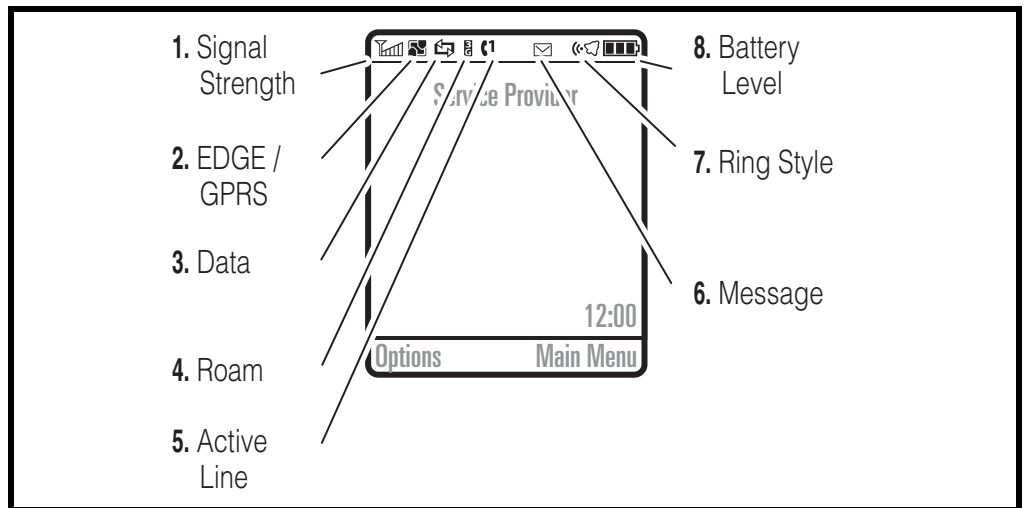

061309a

Figure 2. Icon Indicators



Whether a phone displays all indicators depends on the programming and services to which the user subscribes.

1. **Signal Strength Indicator** – Vertical bars show the strength of the network connection. You can’t make or receive calls when or shows.
2. **EDGE/GPRS Indicator** – Shows when your phone is using a high-speed *Enhanced Data for GSM Evolution (EDGE) or General Packet Radio Service (GPRS) network connection. Indicators can include:*









- GPRS PDP context active
- EDGE
- GPRS packet data available



3. **Data Indicator** – Shows connection status.





- secure packet data transfer
- unsecure packet data transfer
- secure application connection
- unsecure application connection
- secure *Circuit Switch Data (CSD)* call
- unsecure CSD call
- High-Speed Downlink Packet Access (HSDPA)* data transfer
- Bluetooth™ connection is active











4. **Roam Indicator** – Shows when your phone is seeking or using a network outside your home network. Indicators can include: 

 2G home	 2G roam
 2.5G home	 2.5G roam
 3G home	 3G roam
 HSDPA home	 HSDPA roam

HSDPA is *High-Speed Downlink Packet Access*, available on some networks.
5. **Active Line Indicator** – Shows  to indicate an active call, or  to indicate when call diverting is on. Indicators for dual-line-enabled SIM cards can include: 

 line 1 active	 line 1 active, call divert on
 line 2 active	 line 2 active, call divert on
6. **Message Indicator** – Shows when you receive a new message. Indicators can include: 

 text message	 voice message
------------------------------------------------------------------------------------------------	-------------------------------------------------------------------------------------------------
7. **Ring Style Indicator** – Shows the ring style setting.

 loud ring	 vibrate & ring
 soft ring	 vibrate then ring
 vibrate	 silent
8. **Battery Level Indicator** – Vertical bars show the battery charge level. Recharge the battery when your phone shows **Low Battery**.

Alert Settings

K3 telephones include up to 32 preset alert tones and vibrations that can be applied to all alert events at the same time.



Pressing any volume key mutes the alert.

Battery Function

Battery Gauge

The telephone displays a battery level indicator icon in the idle screen to indicate the battery charge level. The gauge shows four levels: 100%, 66%, 33%, and Low Battery.

Battery Removal

Removing the battery causes the device to immediately shut down and any pending work (for example, partially entered phone book entries or outgoing messages) is lost.



If the battery is removed while receiving a message, the message will be lost.

Operation

For detailed operating instructions, refer to the appropriate User's Guide.

Tools and Test Equipment

The following table lists tools and test equipment recommended for disassembly and reassembly of K3 telephones. Use either the listed items or equivalents.

Table 1. General Test Equipment and Tools

Part Number ¹	Description	Application
RSX4043-A	Torque Driver	Used to remove and replace screws
—	Torque Driver Bit T-5 Plus, Apex 440-6IP Torx Plus or equivalent	Used with torque driver
See Table 7	Rapid Charger	Used to charge battery and to power device
0180386A82	Antistatic Mat Kit (includes 66-80387A95 antistatic mat, 66-80334B36 ground cord, and 42-80385A59 wrist band)	Provides protection from damage to device caused by electrostatic discharge (ESD)
6680388B67	Disassembly tool, plastic with flat and pointed ends (manual opening tool)	Used during assembly/disassembly of device
6680388B01	Tweezers, plastic	Used during assembly/disassembly
	Tweezers, metal	Used during assembly/disassembly
—	Digital Multimeter, HP34401A ²	Used to measure battery voltage
19501980 ³	Generic Press Fixture	Must be used to install keypad mylar
0-00-00-40862 ³	K3 EL & Side key alignment and press fixture	Must be used to install EL Mylar.
0-00-00-40863 ³	Main Lens + CLI Lens + Trim Ring press fixture	Must be used to install main lens and CLI lens and trim ring
8102430Z04	GSM / DCS Test SIM	Used to enable manual test mode

1. To order in North America, contact Motorola Aftermarket and Accessories Division (AAD) at (800) 422-4210 or FAX (800) 622-6210; Internationally, AAD can be reached by calling (847) 538-8023 or faxing (847) 576-3023.

2. Not available from Motorola. To order, contact Hewlett Packard at (800) 452-4844.

3. Available at the AMS Online-shop 62.214.1.200 (for access, please contact your local Motorola parts representative)

Disassembly

The procedures in this section provide instructions for the disassembly of K3 telephones. Tools and equipment used for the phone are listed in Table 1, preceding.



Many of the integrated devices used in this equipment are vulnerable to damage from electrostatic discharge (ESD). Ensure adequate static protection is in place when handling, shipping, and servicing the internal components of this equipment.



Avoid stressing the plastic in any way to avoid damage to either the plastic or internal components.

Removing and Replacing the Battery Door and Battery



All batteries can cause property damage and / or bodily injury, such as, burns if a conductive material, such as, jewelry, keys, or beaded chains touch exposed terminals. The conductive material may complete an electrical circuit (short circuit) and become quite hot. Exercise care in handling any charged battery, particularly when placing it inside a pocket, purse, or other container with metal objects.

1. Ensure the phone is turned off.
2. Press in the battery door latch, as shown in Figure 1.

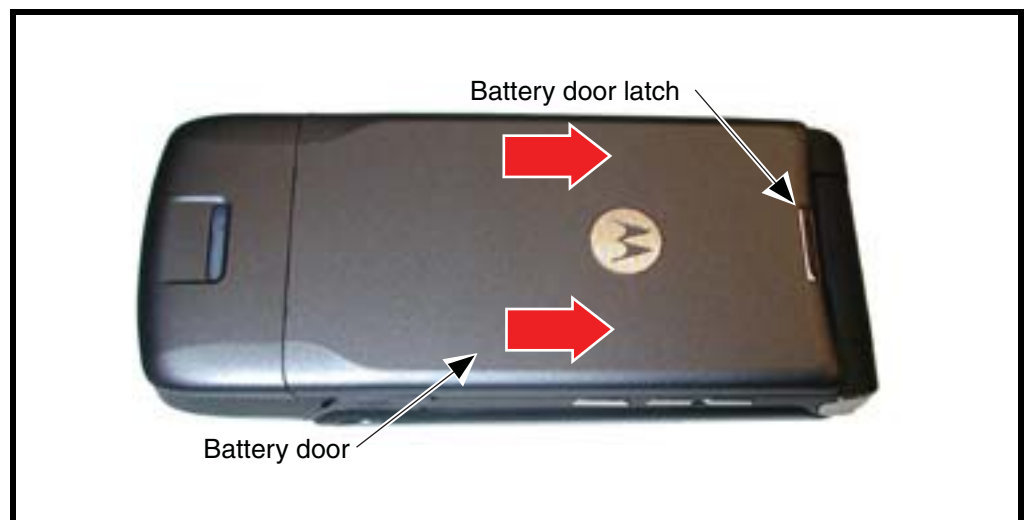

Figure 1. Removing the Battery Door

3. Slide the battery door forward and lift it completely off the phone.

4. Lift the top end of the battery first, then remove the battery from the phone. See Figure 2.



Figure 2. Removing the Battery

0653180



There is a danger of explosion if the Lithium Ion battery is replaced incorrectly. Replace only with the same type of battery or equivalent as recommended by the battery manufacturer. Dispose of used batteries according to the manufacturer's instructions.

5. To replace, align the battery with the battery compartment so the contacts on the battery match the battery contacts in the phone.
6. Insert the battery, contacts side first, into the battery compartment followed by the opposite edge of the battery.
7. Place the battery door onto the rear housing, then slide the battery door toward the battery door latch until it snaps into place.

Removing and Replacing the Trans Flash Memory Module

1. Remove the battery cover and battery, as described in the procedures.
2. If a memory card is present, slide it out of its slot as shown in Figure 3.

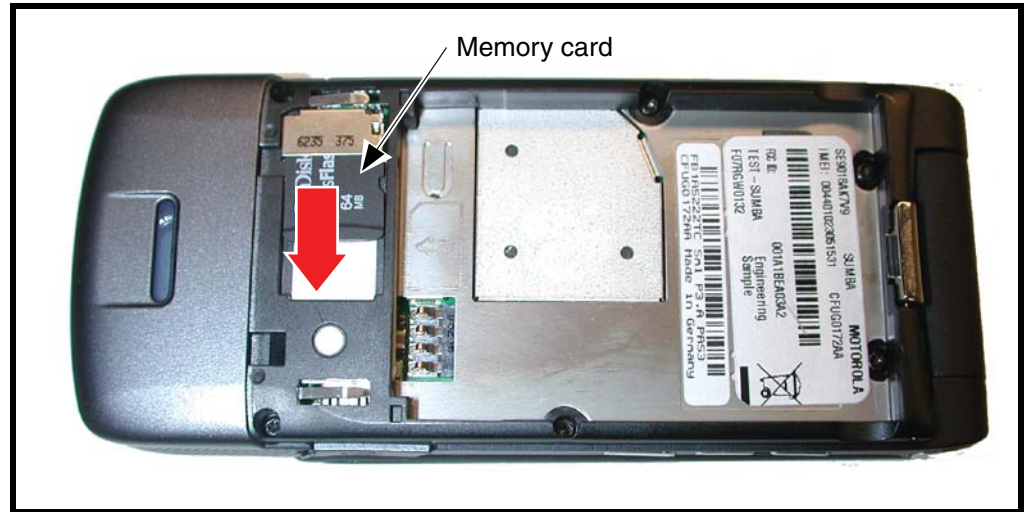

0653190

Figure 3. Removing the Memory Card

3. Lift the memory module out of the phone.
4. To replace, align the memory module according to the diagram in the phone.
5. Place the memory module into its slot with the contacts facing down and slide it all the way into position.
6. Reinstall the battery, and battery cover as described in the procedures.

Removing and Replacing the Subscriber Identity Module (SIM)

1. Remove the battery cover, battery, and memory module as described in the procedures.
2. Slide the SIM card toward the phone's battery compartment, as shown in Figure 3.
3. Carefully lift the SIM from the phone.
4. To replace, insert the SIM into the holder, ensuring the keyed corner of the SIM faces the outward edge of the phone (see Figure 4).

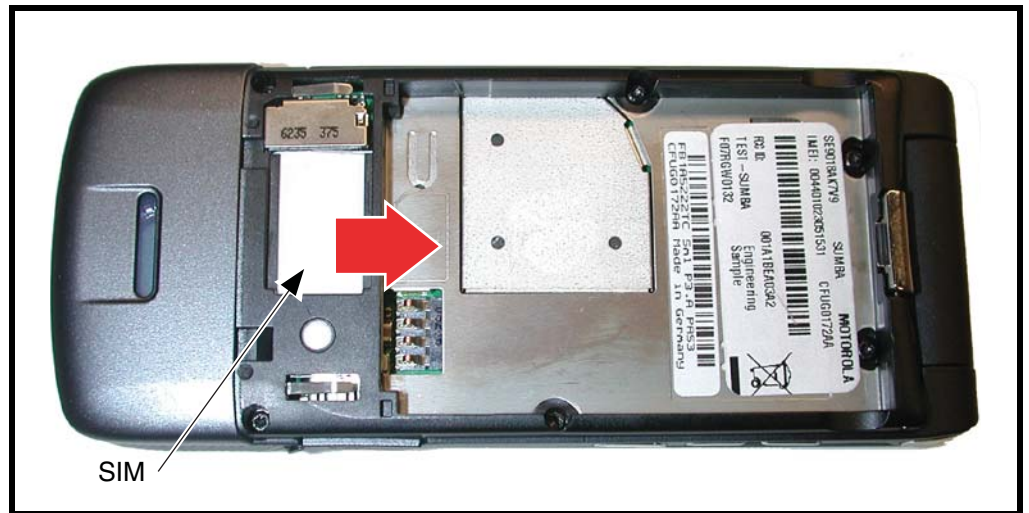

Figure 4. Removing the SIM

0653200

5. Replace the battery and battery cover as described in the procedures.

Removing and Replacing the Rear Housing



This product contains static-sensitive devices. Use anti-static handling procedures to prevent electrostatic discharge (ESD) and component damage.

1. Remove the battery door, battery, and SIM as described in the procedures.



In addition to 6 screws, the rear housing assembly is fastened with plastic latches. These are fragile and should be released with care.

2. Using a Torx driver with a T-5 bit, remove the 6 housing screws. Retain the screws for reassembly. See Figure 5.

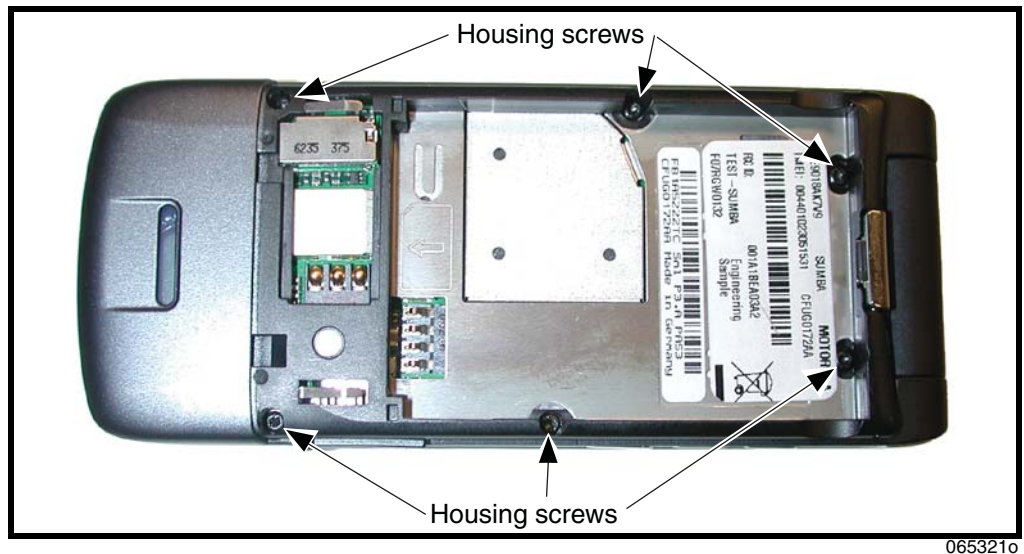

0653210

Figure 5. Removing the Rear Housing Screws

3. Release the four housing latches by inserting the pointed end of the plastic disassembly tool into the openings on the rear housing.

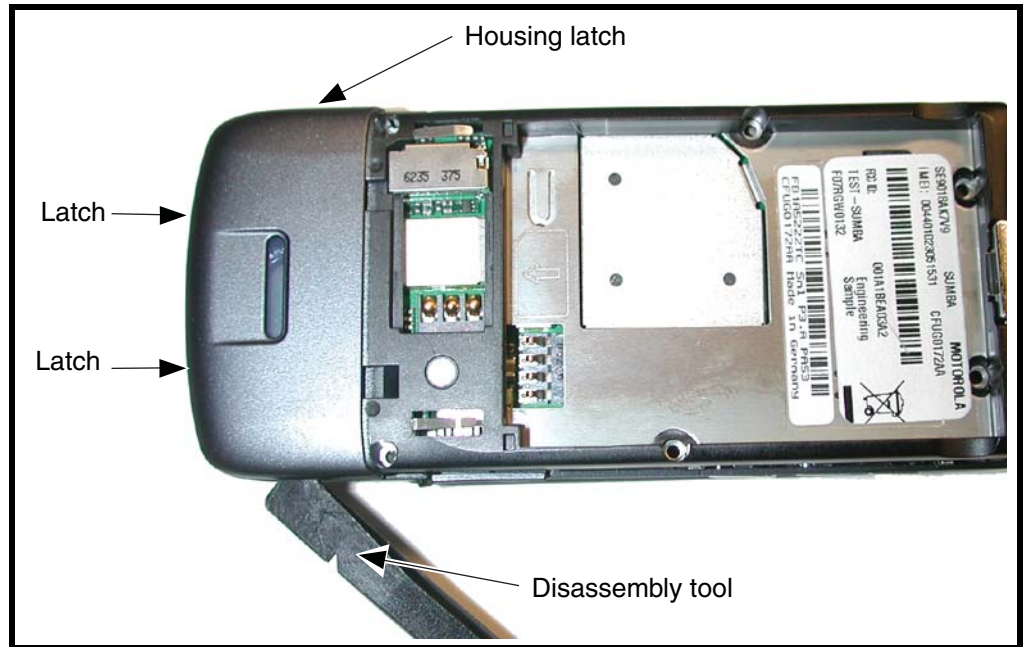

0653260

Figure 6. Removing the Rear Housing Latches

4. Carefully rotate the rear housing away from the front housing.
5. Lift the rear housing assembly away from the phone.
6. To replace, align the housing latches with the corresponding openings on the front housing. Gently press the housings together until the catches snap into place.
7. Replace the 6 housing screws and tighten to a final torque setting of 16 Ncm (1.5 inch pounds). Do not over tighten.
8. Replace the SIM, battery, and battery cover as described in the procedures.

Removing and Replacing the Transceiver Board Assembly



This product contains static-sensitive devices. Use anti-static handling procedures to prevent electrostatic discharge (ESD) and component damage.

1. Remove the battery cover, battery, SIM, and rear housing as described in the procedures.
2. Use the plastic tweezers to remove the EMU grommet on the transceiver board assembly (see Figure 7).

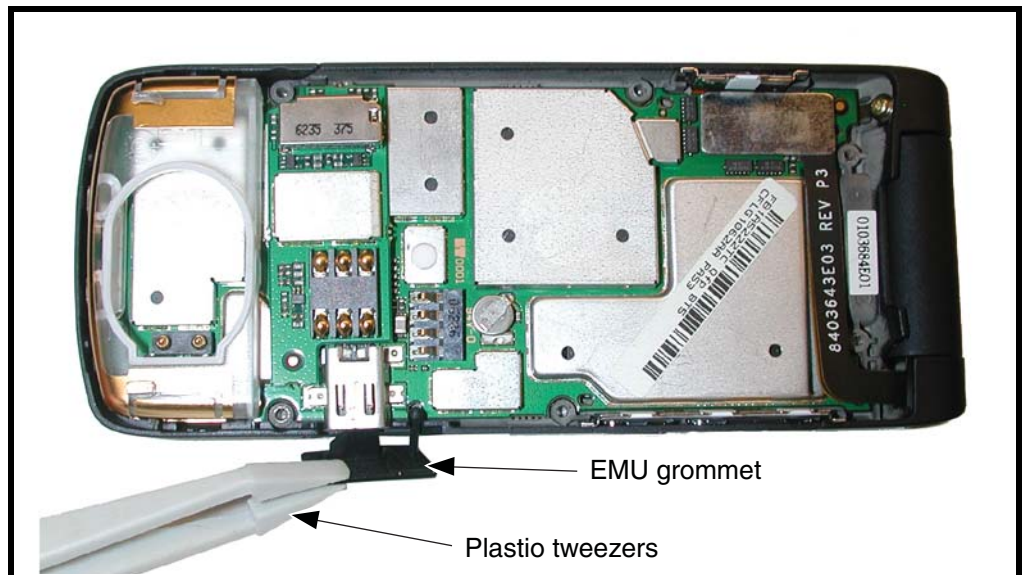

0653290

Figure 7. Removing the EMU Grommet

3. Use the disassembly tool to unseat the display flex connector from its socket on the transceiver board assembly (see Figure 8).

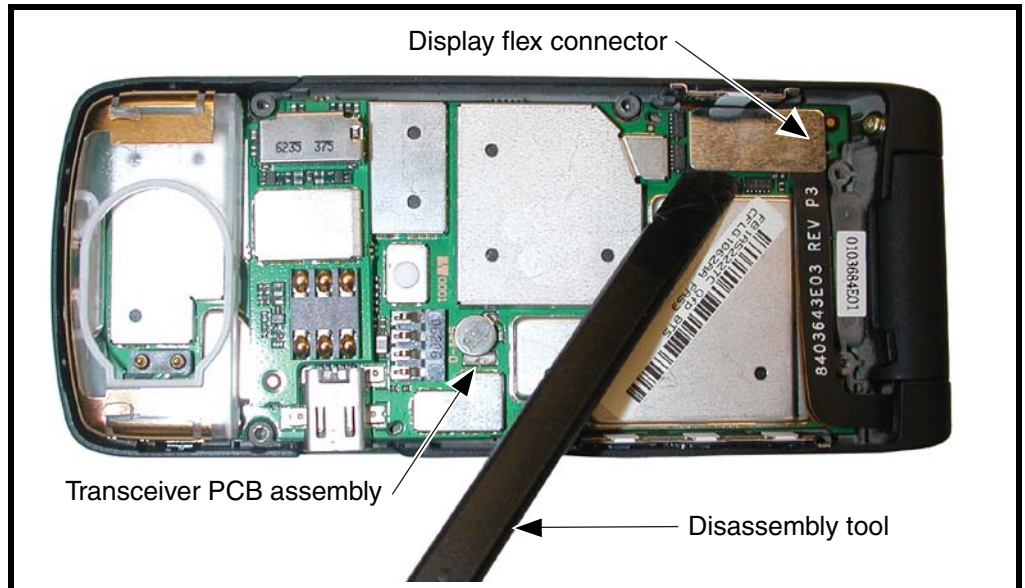

065330o

Figure 8. Removing the Flex Connector

4. Use the disassembly tool to lift the transceiver board assembly out of the front housing.

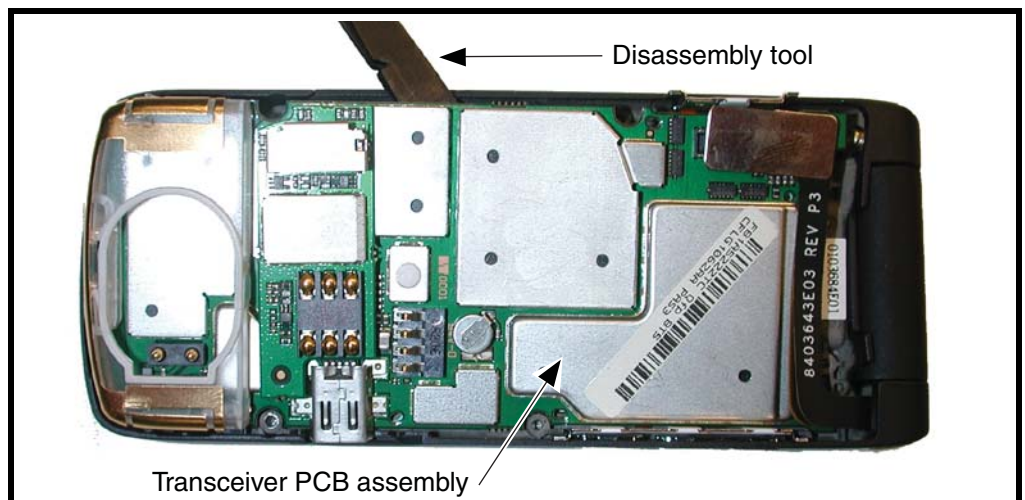

070025o

Figure 9. Removing the Transceiver PC Board Assembly

5. To replace, place transceiver board into the front housing. Tip the PCB in on an angle, first inserting the side with three side switches. Take care to clear the side keys with the PCB or damage will result. Slowly angle the PCB until it is flat in the housing. The top of the PCB must fit around the screw bosses of the front housing.

Removing and Replacing the Daughter Board Assembly

1. Use the disassembly tool to separate the daughter board from the main PC board. Be careful to avoid damage to components on the transceiver PCB assembly (see Figure 10).

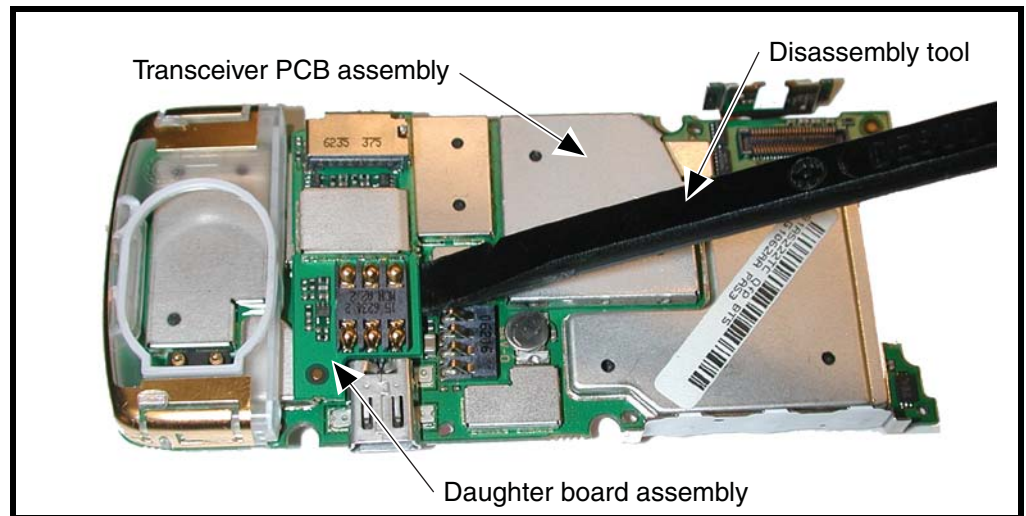

0700370

Figure 10. Removing the Daughter Board

2. Carefully remove the daughter board from the transceiver PC board.
3. To replace, align the daughter board connector to the main PC board socket and carefully press into position.
4. Connect the flex connector to the transceiver board assembly.
5. Connect the USB grommet to the front housing.
6. Replace the transceiver board assembly, rear housing, SIM, battery, and battery cover as described in the procedures.

Removing and Replacing the Keypad

1. Remove the battery cover, battery, SIM card, antenna, rear housing, and transceiver PC board, as described in the procedures.
2. Using the plastic tweezers, gently lift up the keypad and remove it from the front housing, as shown in Figure 11.

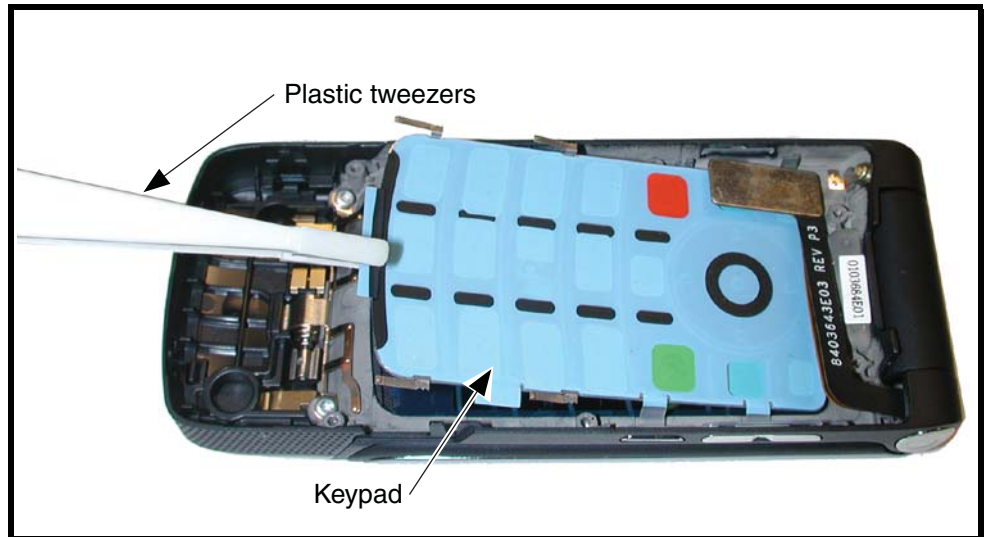

0612680

Figure 11. Removing and Replacing the Keypad

3. To replace, align the keypad with the front housing and lower it into place.
4. Replace the transceiver PC board, rear housing, SIM, battery, and battery cover as described in the procedures.

Removing and Replacing the Antenna Assembly

1. Remove the battery cover, battery, SIM, and rear housing assembly, transceiver PC board assembly, as described in the procedures.
2. Turn the transceiver board assembly over so that the keypad mylar is facing upward.
3. Use the pointed end of the disassembly tool to release the antenna assembly latch on each side of the transceiver board assembly.

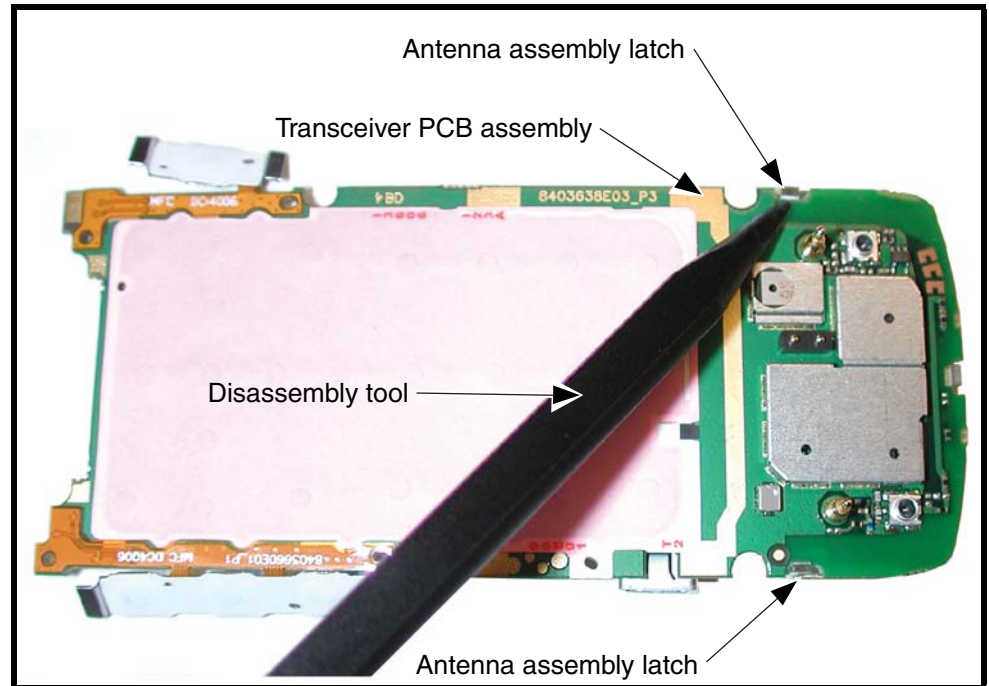

0700380

Figure 12. Removing the Antenna Assembly Latches

4. Turn the transceiver board assembly over and use the plastic tweezers to lift the antenna assembly away from the transceiver board assembly (see Figure 13).

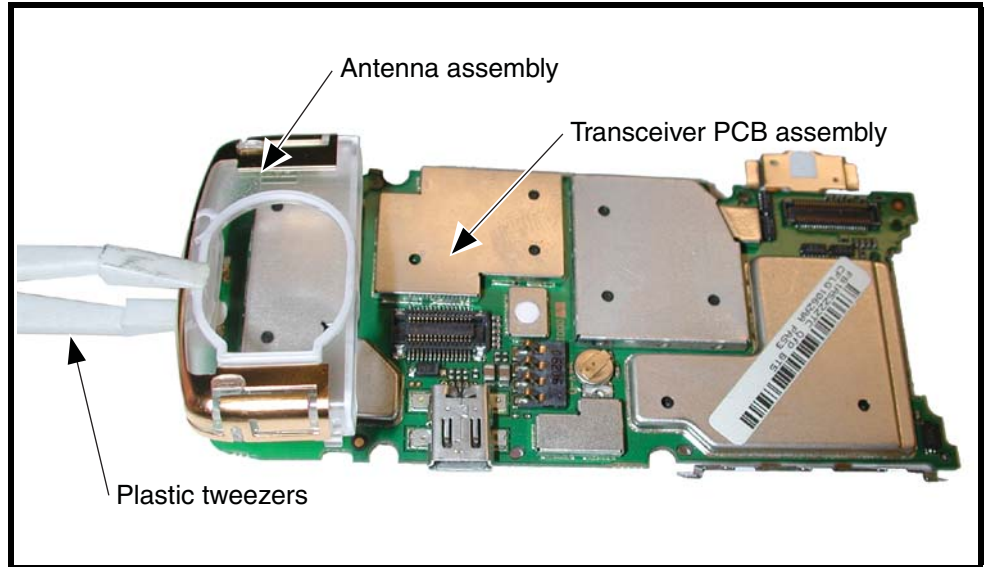

Figure 13. Removing and Replacing the Antenna Assembly

5. To replace, carefully align the antenna assembly to the transceiver board assembly. Carefully press the antenna assembly into position on the transceiver board assembly until the latches engage.
6. Replace the transceiver PC board assembly, rear housing assembly, SIM, battery, and battery cover, as described in the procedures.

Removing and Replacing the Keypad Mylar



It is mandatory that the following special tools must be used when following this procedure:

K3 EL and Acoustic Gasket Alignment- and Press Tool - part number 0-00-00-40862

Generic Press Fixture - part number 19501980 Available at the AMS Online-shop 62.214.1.200 (for access please contact your local Motorola contact)

The K3 EL and acoustic gasket alignment and press tool must be used for this replacement procedure.

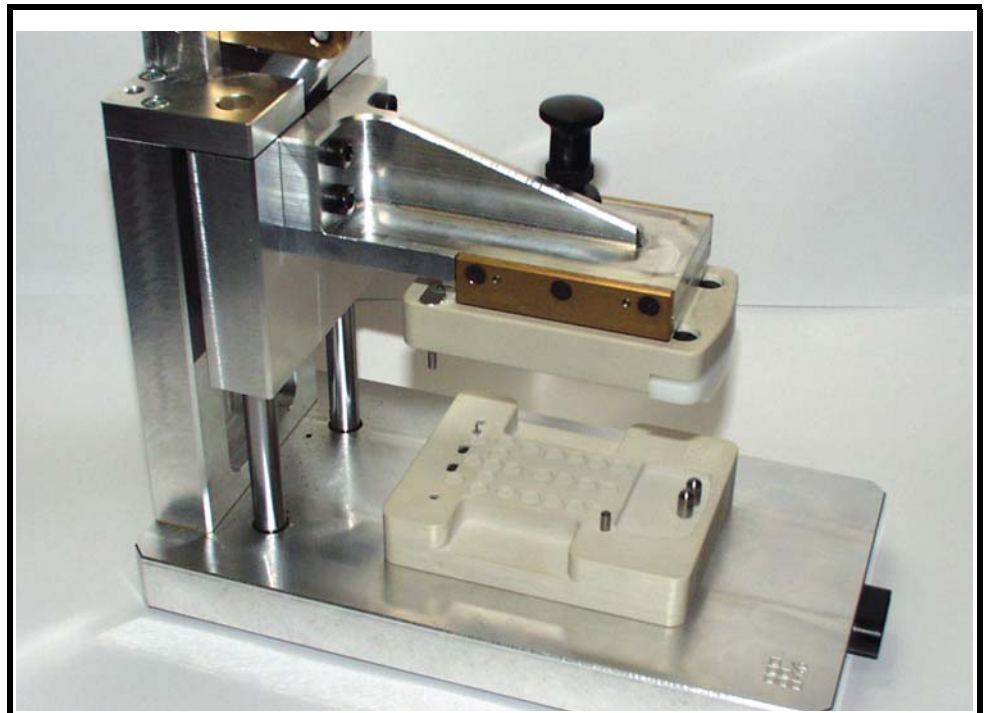

0619270

Figure 14. K3 EL Panel Alignment and Press Tool

1. Remove the keypad mylar with plastic tweezers, as shown.

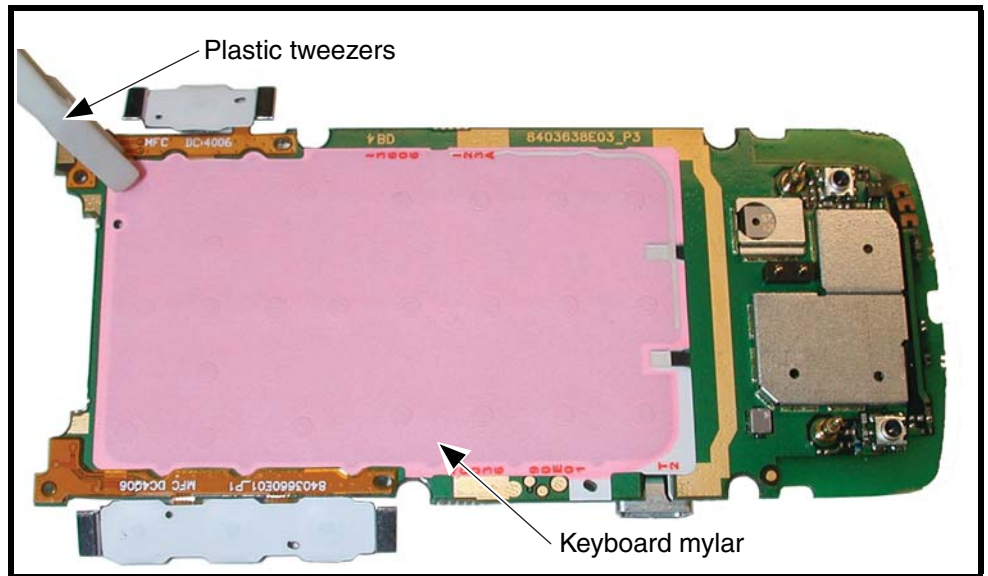

0702100

Figure 15. Removing the Keypad Mylar

2. To replace the keypad mylar, use the K3 EL and Acoustic Gasket Alignment and Press tool.
3. Peel off the adhesive liner from the bottom side of the keypad mylar. Place the keypad into the fixture. Align the keypad using the fixture alignment pins.

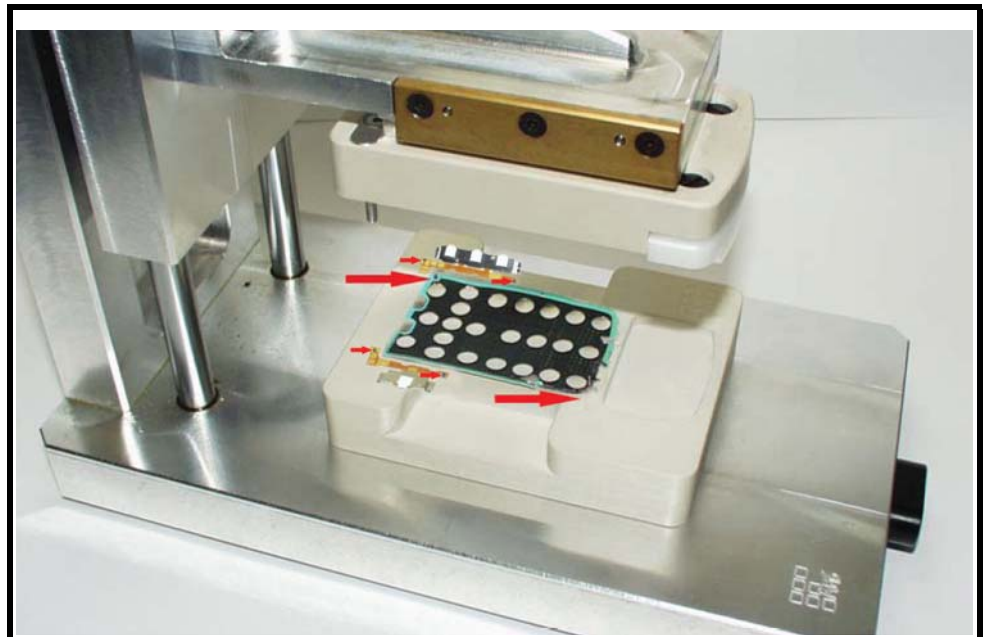

0702110

Figure 16. Keypad Mylar Alignment

4. Clean the mylar area on the main PCB, and then place it on top of the keypad mylar using the fixture alignment pins.

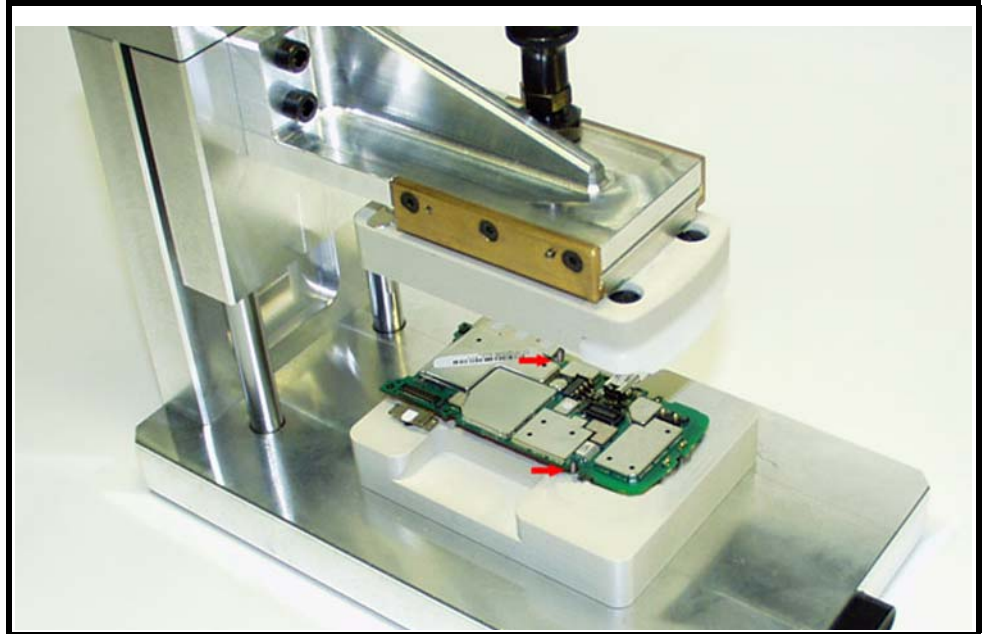
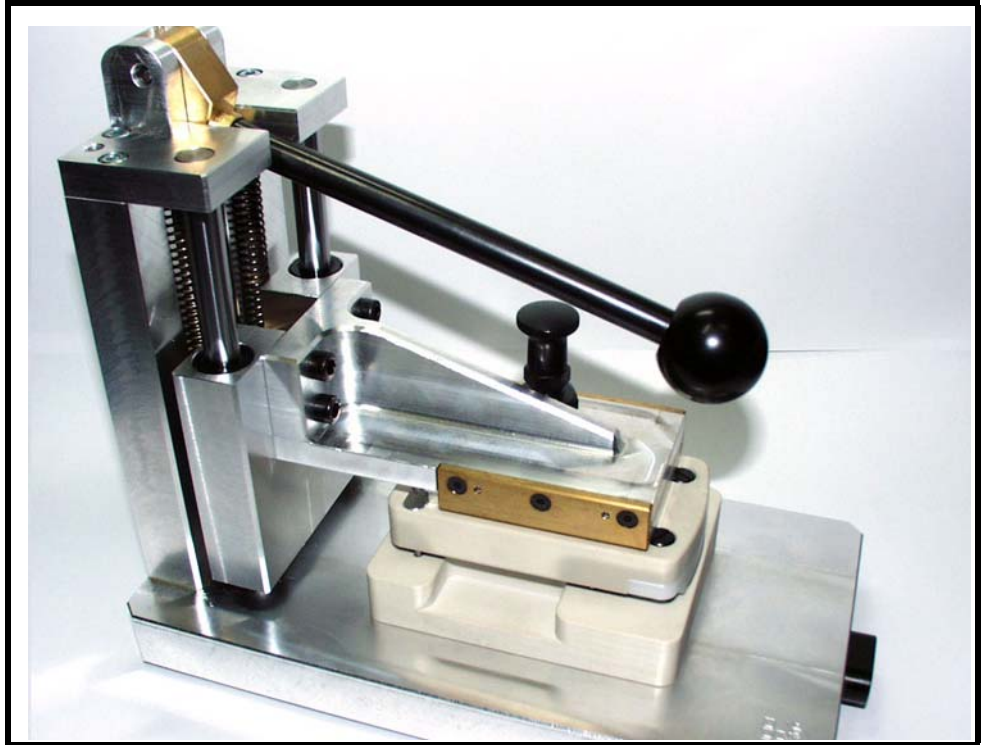

Figure 17. PCB Alignment

070212o

5. Close the fixture for 15 seconds.

6. Open the fixture and check the assembly for correct positioning of the mylar and acoustic gasket on the PCB.



0619310

Figure 18. EL Mylar and Side Key Press Closed

Removing and Replacing the Flip Assembly Cover

1. Remove the battery cover, battery, SIM, rear housing, and transceiver board assembly as described in the procedures.
2. Slide the disassembly tool along the sides of the flip assembly to separate the flip cover bezel from the flip assembly.

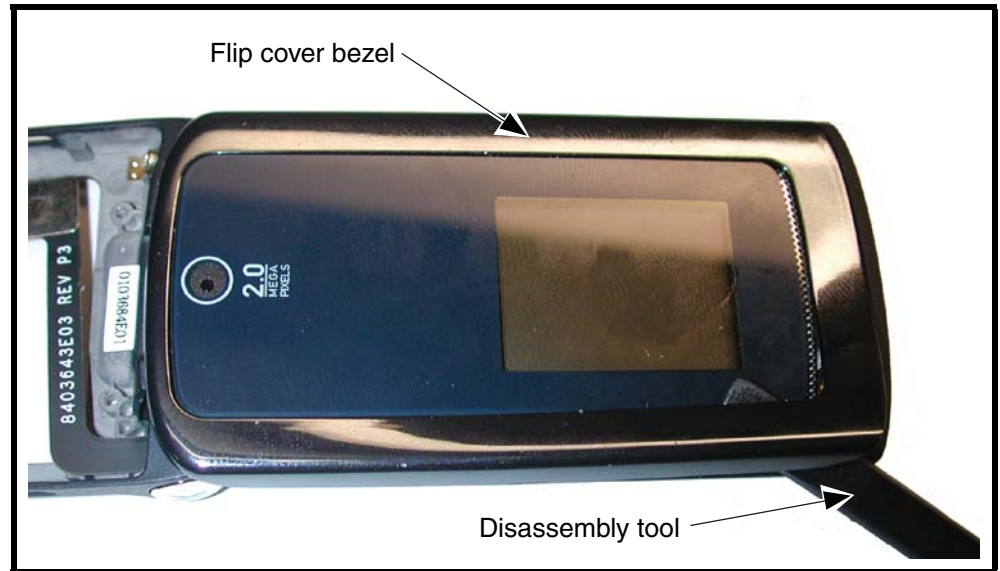

Figure 19. Removing the Flip Assembly Bezel

3. Carefully lift the flip assembly bezel from the flip assembly.

4. Use the T-5 driver to remove the 4 screws from the flip assembly (see Figure 20). Retain the screws for reassembly.

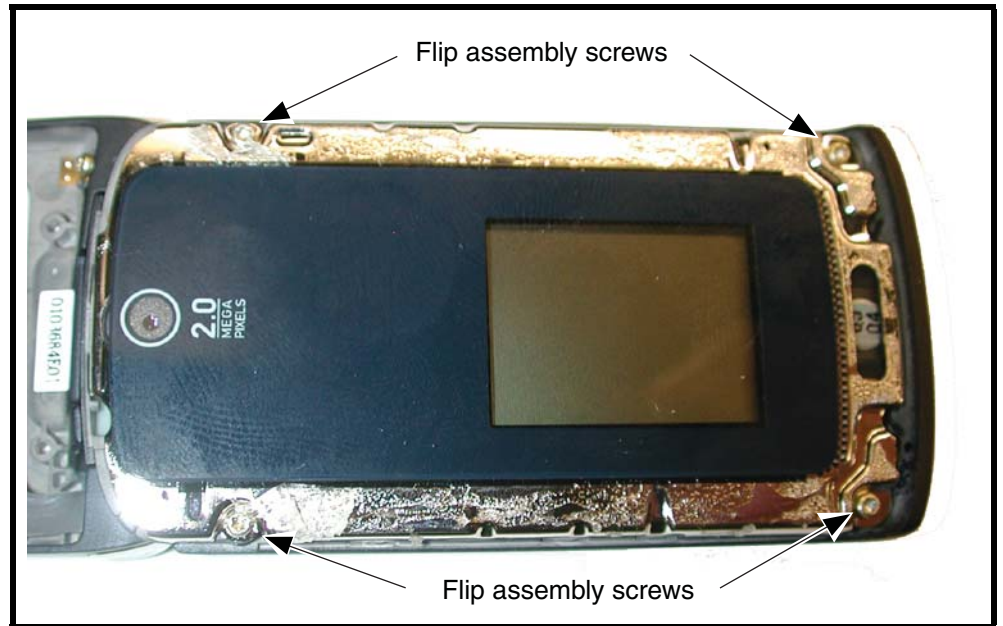

Figure 20. Removing the Flip Assembly Screws

0700910

5. Lift the flip cover away from the flip assembly. Be careful not to damage the display flex cable.
6. To replace, insert and tighten the 4 flip assembly screws with the T-5 driver. Tighten to final torque setting of 16 Ncm (1.5 inch lbs.).
7. Align the flip assembly bezel to the flip assembly.
8. Expose the adhesive surface and carefully press flip bezel onto the flip cover.
9. Replace the transceiver board assembly, rear housing, battery, and battery as described in the procedures.

Removing and Replacing the Display Module Assembly

1. Remove the battery cover, battery, SIM, rear housing, antenna, transceiver board assembly, flip assembly cover, and camera assembly, as described in the procedures.



The flexible printed cable (FPC) (flex) is easily damaged. Exercise extreme care when handling.

2. Use the disassembly tool to unseat the flip assembly flex connector from its socket (see Figure 21).

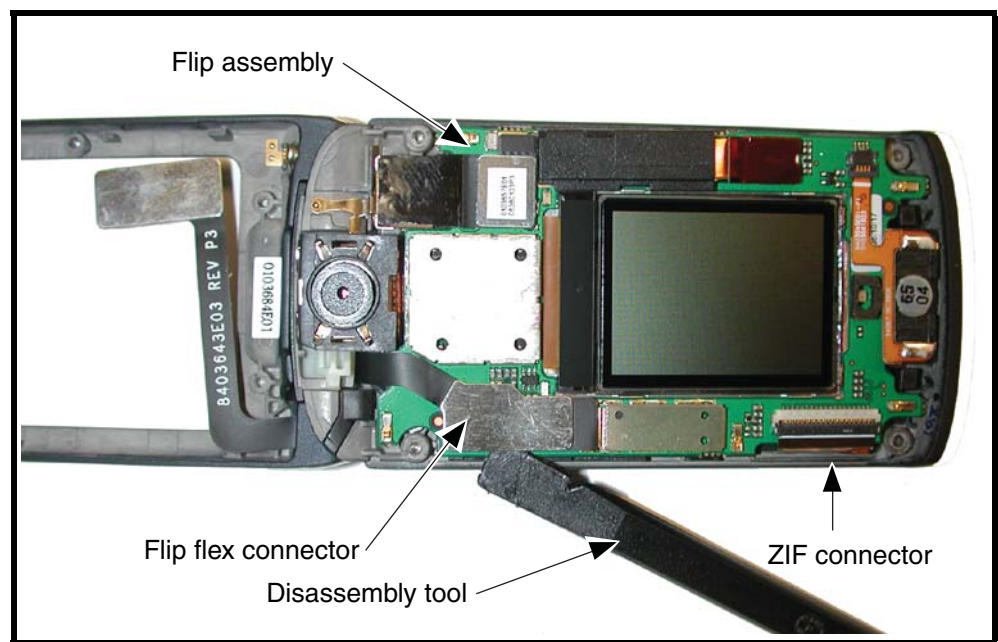

070093o

Figure 21. Flip Assembly Flex Connector

3. Carefully and gently lift one corner of the display module assembly out of the flip assembly.

4. Use the plastic tweezers to carefully lift the flip PCB assembly away from the flip housing (see Figure 22).

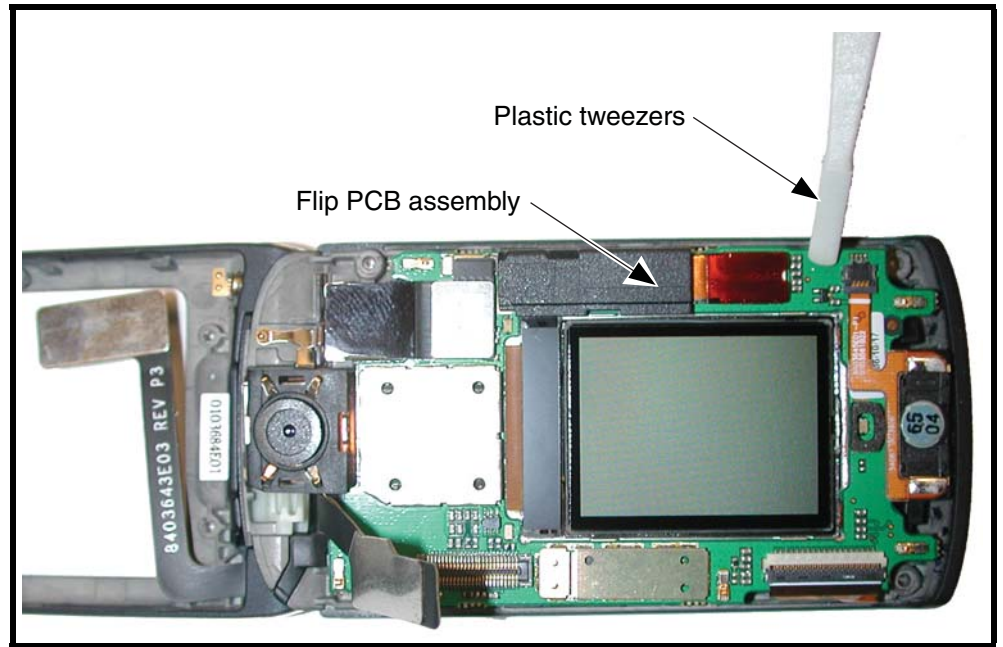

0700940

Figure 22. Removing the Flip PCB Assembly

5. To replace, align the flip PCB assembly to the flip assembly.
6. Carefully lower the flip PCB into the flip assembly. Avoid damaging any of the display assembly components.
7. Align the flip display flex to the flex connector on the flip display assembly and gently press the flex connector into its socket until properly seated.
8. Replace the flip assembly cover, flip assembly bezel, transceiver board, rear housing, SIM, battery, and battery connector as described in the procedures.

Removing and Replacing the VGA Camera Assembly

1. Remove the battery door, battery, SIM card, antenna, rear housing, transceiver PC board assembly, flip bezel, flip cover, and flip PCB assembly as described in the procedures.
2. Using the disassembly tool, gently unseat the VGA camera connector and remove it from the flip display board, as shown in Figure 23.

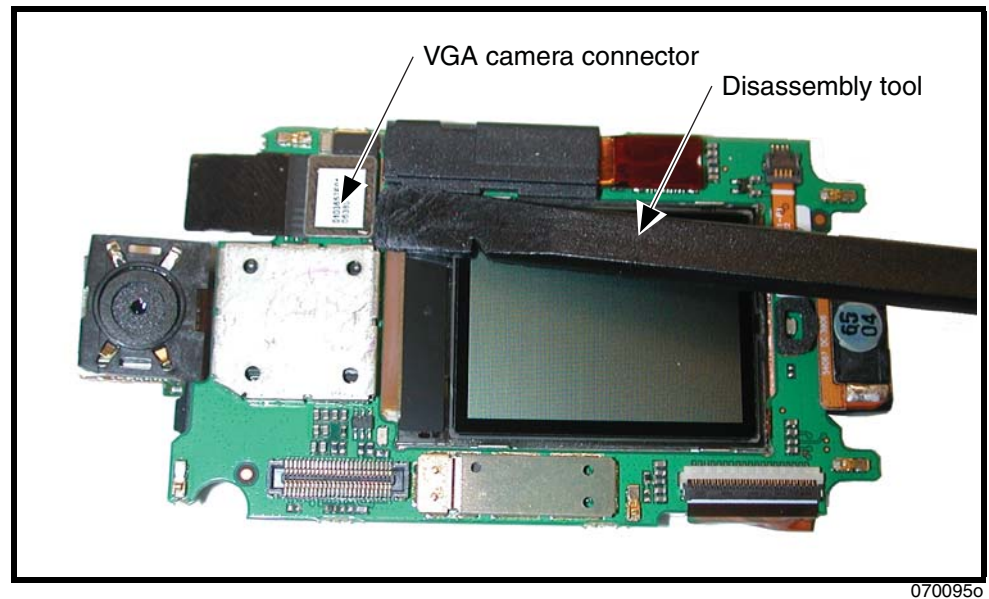

Figure 23. Removing and Replacing the VGA Camera Assembly

3. To replace, carefully press the VGA camera assembly into its slot in the flip assembly.
4. Gently press the end of the VGA camera assembly flex connector into its socket connector on the flip display assembly. Avoid damage to the flex cable.

Removing and Replacing the Main Camera Assembly

1. Remove the battery cover, battery, SIM, antenna, rear housing, and transceiver board assembly, flip assembly cover, and flip PCB assembly as described in the procedures.



The flexible printed cable (FPC) (flex) is easily damaged. Exercise extreme care when handling.

2. Turn the flip PCB assembly so the camera connector is facing up.
3. Use the disassembly tool to unseat the main camera assembly connector (see Figure 17).

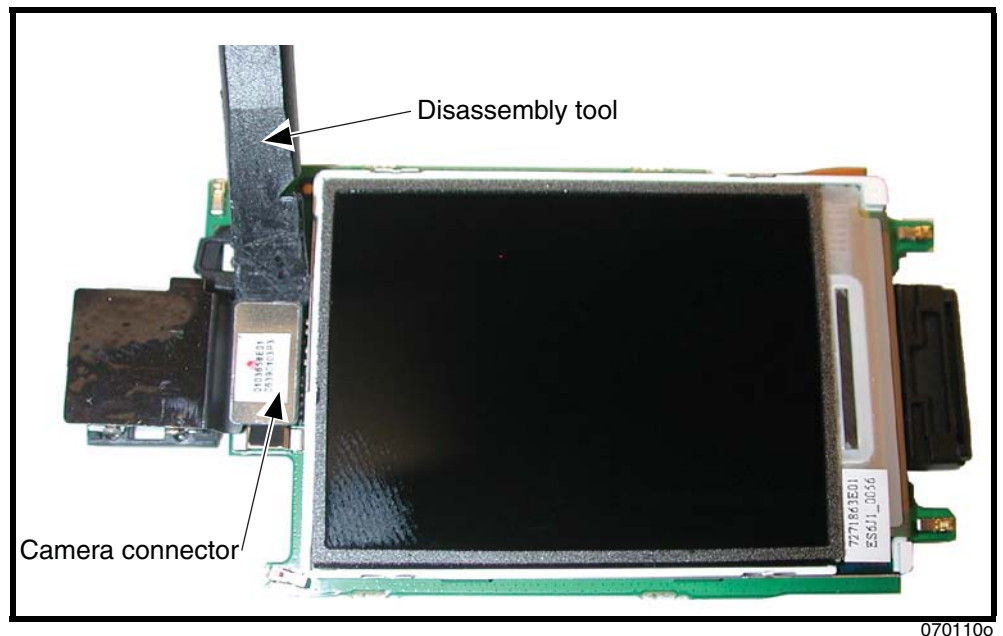

0701100

Figure 24. Camera Assembly Connector Removal

4. To replace, carefully press the camera assembly into its slot in the flip assembly.
5. Gently press the end of the camera assembly flex connector into its socket connector on the flip PCB assembly. Avoid damage to the camera module or the flex.
6. Replace the flip assembly cover, flip cover bezel, transceiver board, rear housing, SIM, battery, and battery door as described in the procedures.

Removing and Replacing the Flip Hinge and Flex Assembly

1. Remove the battery cover, battery, rear housing, antenna, transceiver board assembly, flip assembly cover, and display module assembly, as described in the procedures.
2. Use the T5 driver to remove the hinge cap screw, as shown in Figure 25.

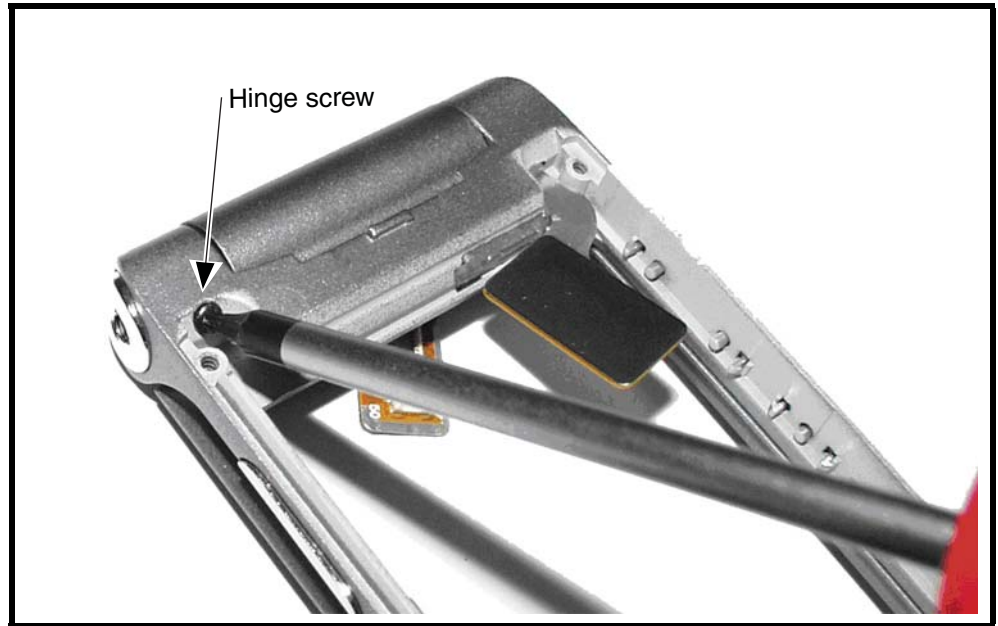

0616880

Figure 25. Removing the Hinge Cap Screws

3. Remove the hinge grommet with the tweezers, as shown in Figure 26.

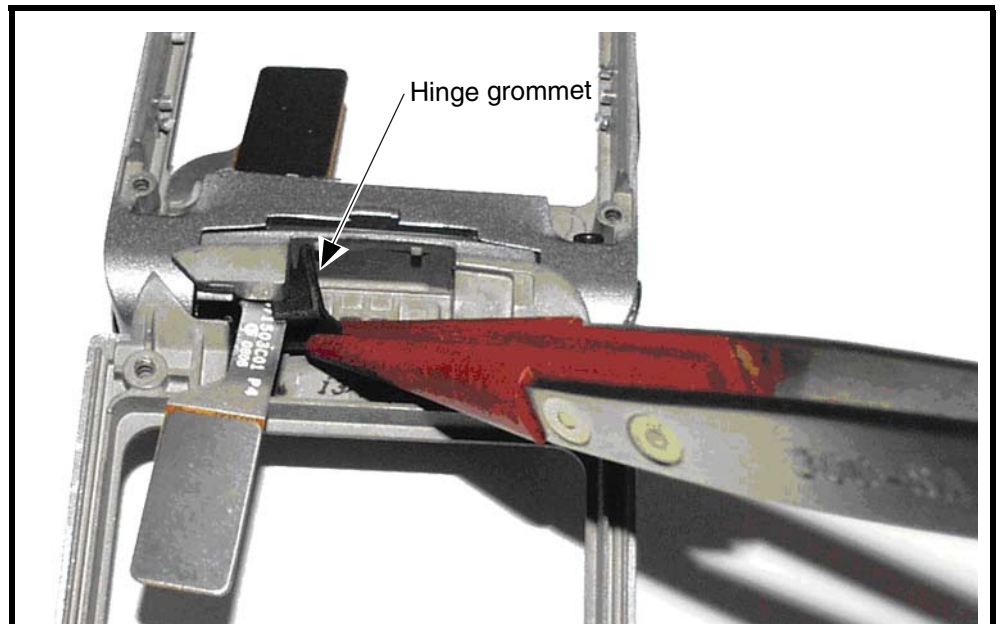

Figure 26. Removing the Hinge Grommet

0616890

4. Remove the left hinge cap and ground clip from the front housing assembly.

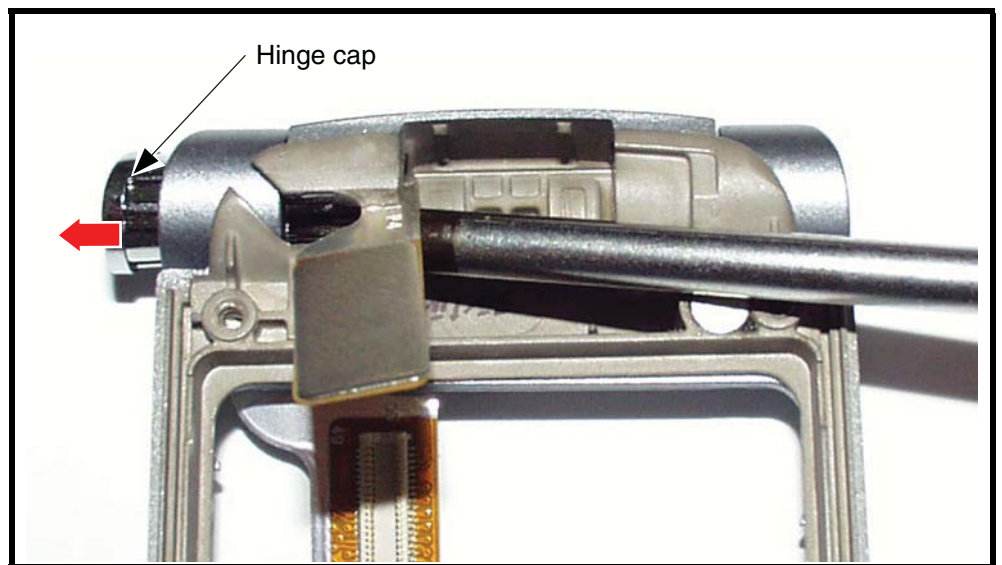
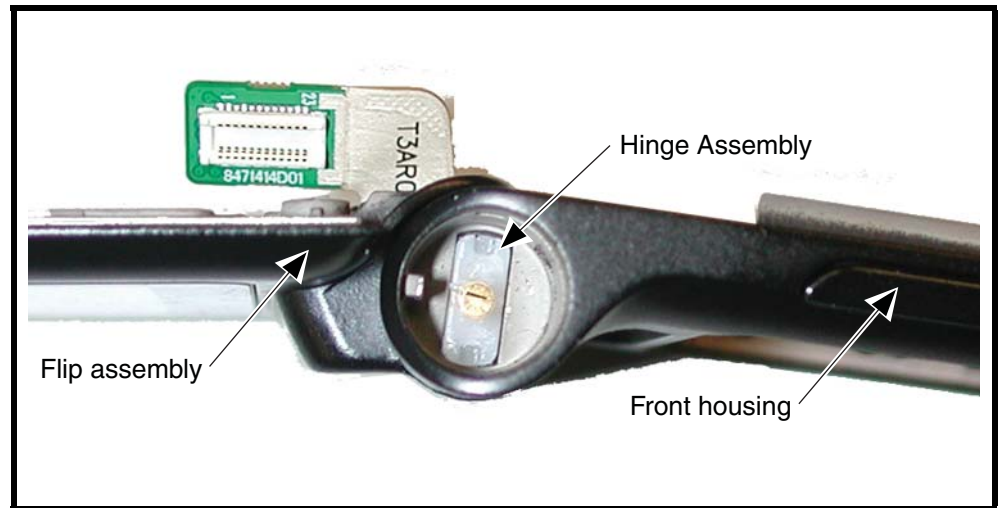

Figure 27. Removing the Hinge Cap

0615480

5. Remove the right hinge cap.

6. Use a small needle nose pliers to press the hinge inward, as shown in Figure 28.



061186o

Figure 28. Hinge Compression

7. While hinge spring is compressed, slide the flip assembly out of the front housing (see Figure 29).

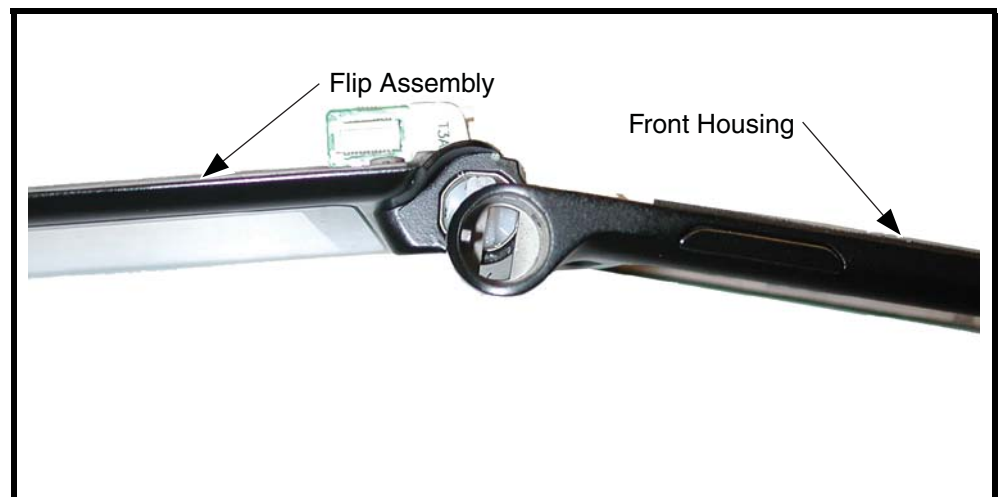

061189o

Figure 29. Removing the Flip Hinge Assembly



The flexible printed cable (FPC) (flex) is easily damaged. Exercise extreme care when handling.

8. Remove the hinge ring and the flex grommet, then carefully slide the flex out of the flip assembly (see Figure 30).

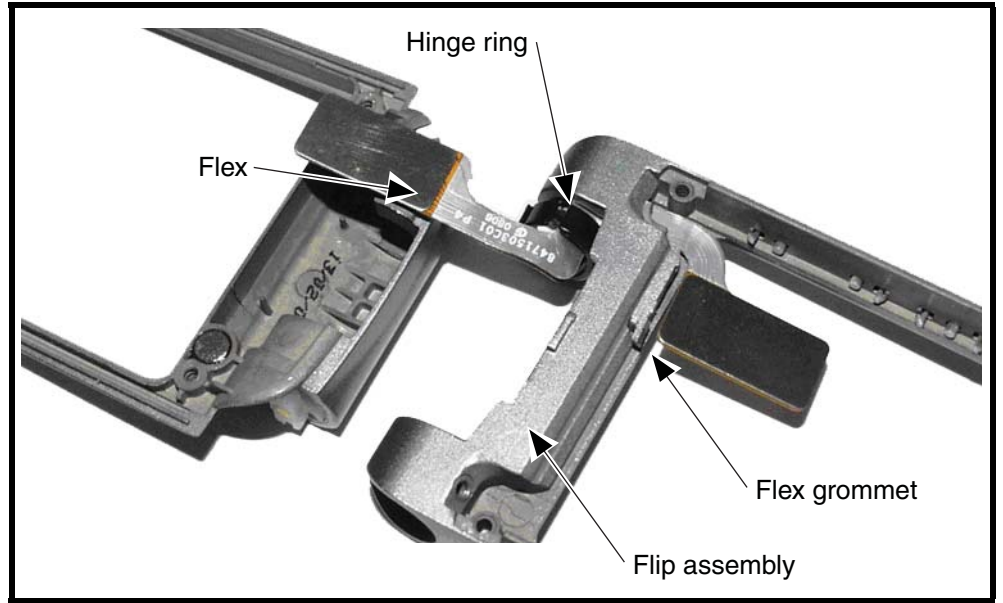

061680o

Figure 30. Removing the Flip Flex



The flexible printed cable (FPC) (flex) is easily damaged. Exercise extreme care when handling.

9. To replace, use the alignment ridges to place the hinge ring into the flip housing (see Figure 31).

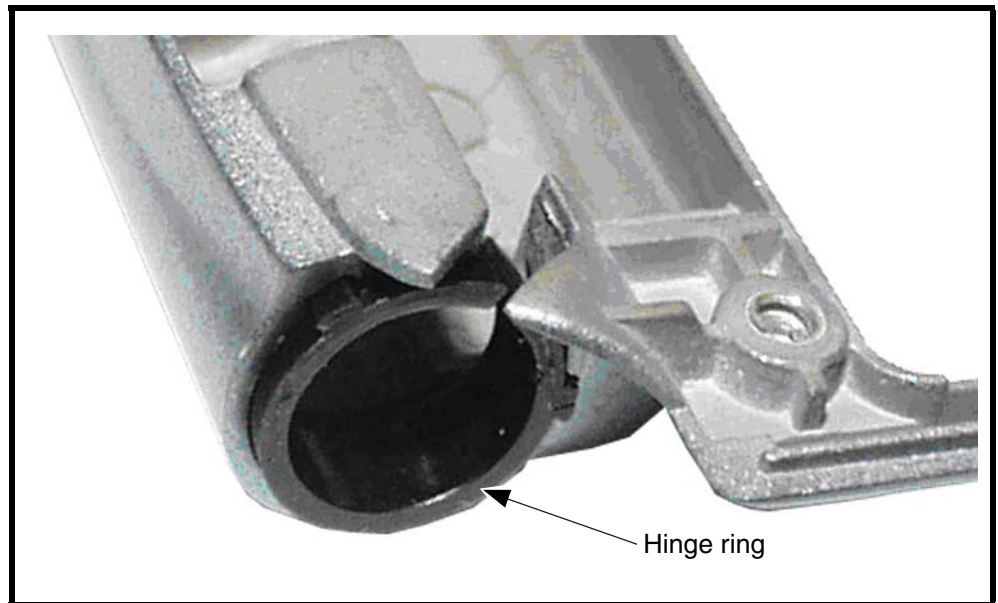

0616810

Figure 31. Placing the Hinge Ring into the Flip Housing

10. Place the flip flex into the gap of the flip housing, as shown in Figure 32.

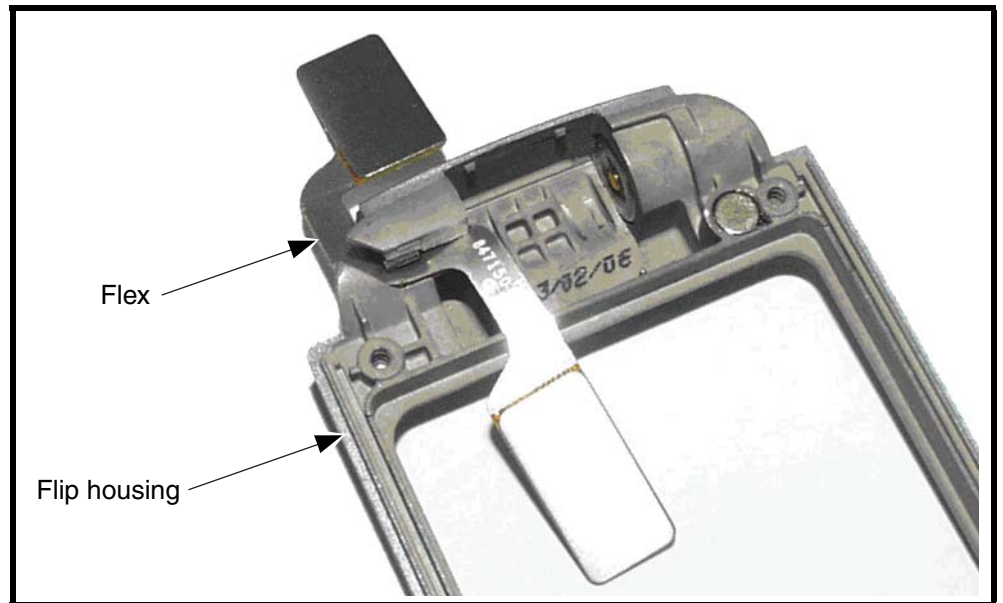

0616820

Figure 32. Placing the Flex into the Flip Housing

11. Align the front housing and the flip housing (see Figure 33). Watch the position of the flex in the hinge.

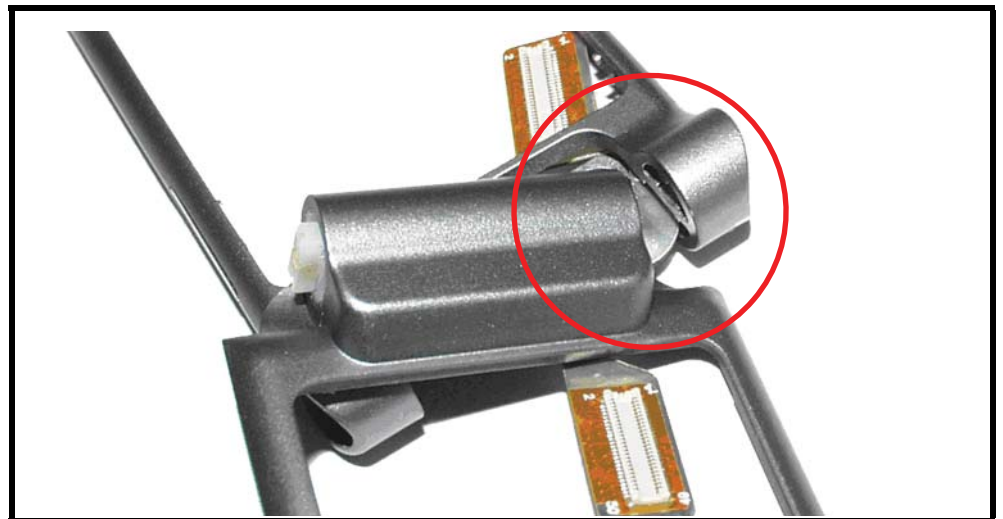

0616840

Figure 33. Align the Front Housing to the Flip Housing

12. Compress the hinge spring and slide the hinge into the front housing (see Figure 34).

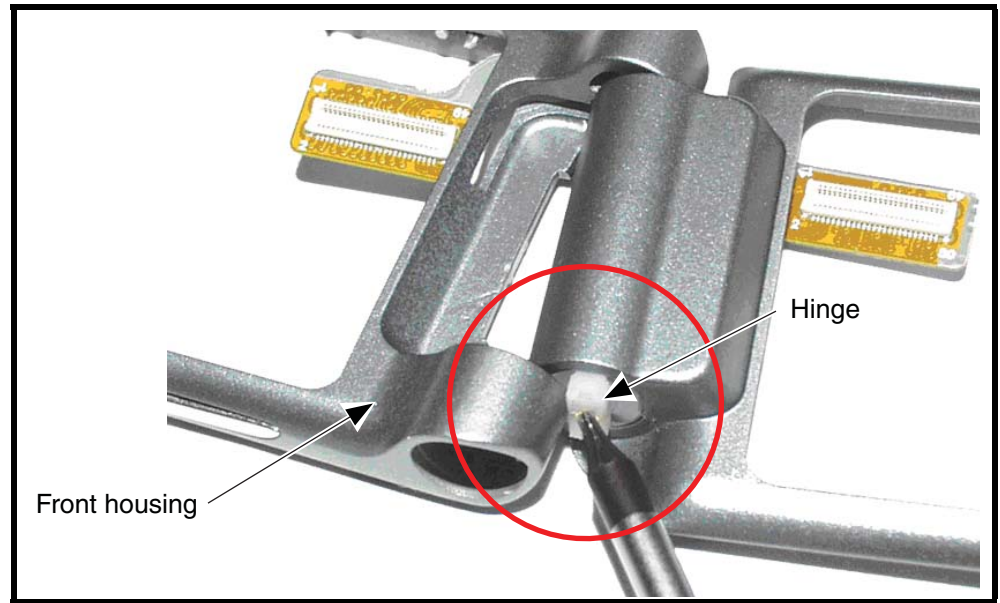

061685o

Figure 34. Compress Flip Hinge and Insert into Front Housing

13. Insert the left and right hinge caps and replace the T5 hinge screw with the Torx driver (see Figure 35).

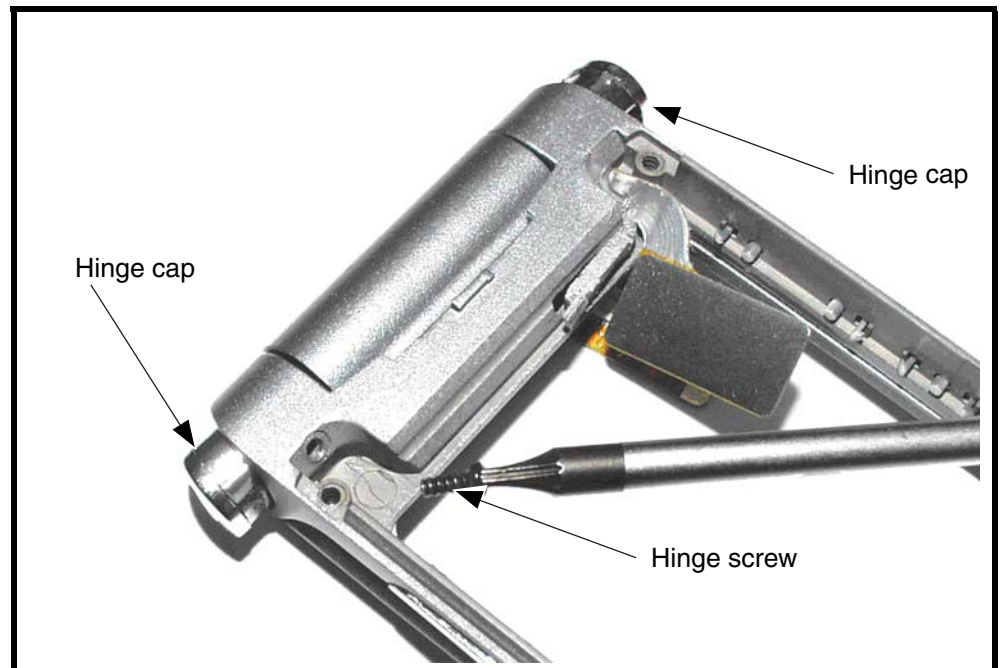

061686o

Figure 35. Replacing the Hinge Caps and Hinge Screw

14. Replace the hinge grommet into the gap between the flex and the flip housing (see Figure 36).

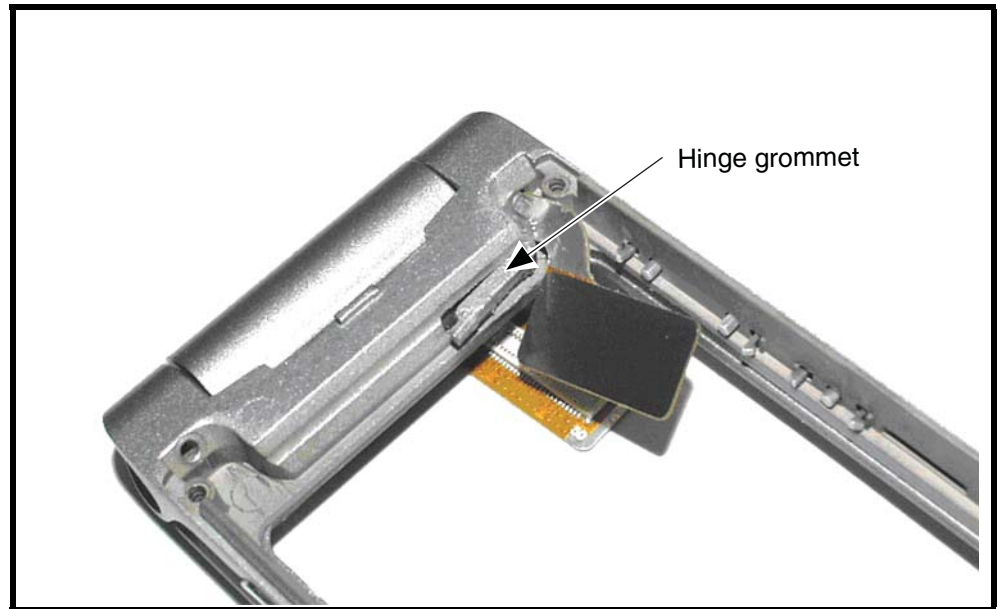

0616870

Figure 36. Replacing the Hinge Grommet

15. Replace the display module assembly, flip assembly cover, transceiver board assembly, antenna, rear housing, SIM, battery, and battery cover as described in the procedures.

Replacing the CLI and Main Display Lens

It is mandatory that the following special tools must be used when following this procedure:



K3 Lens and Trim Ring Press Tool – part number 0-00-00-40863
Generic Press Fixture – part number 19501980

Available at the AMS Online-shop 62.214.1.200 (for access please contact your local Motorola parts representative)

1. Place and align the main lens, the CLI lens, and the trim ring onto the flip assembly.

2. Place the open phone with the main lens up side down into the K3 lens press fixture.

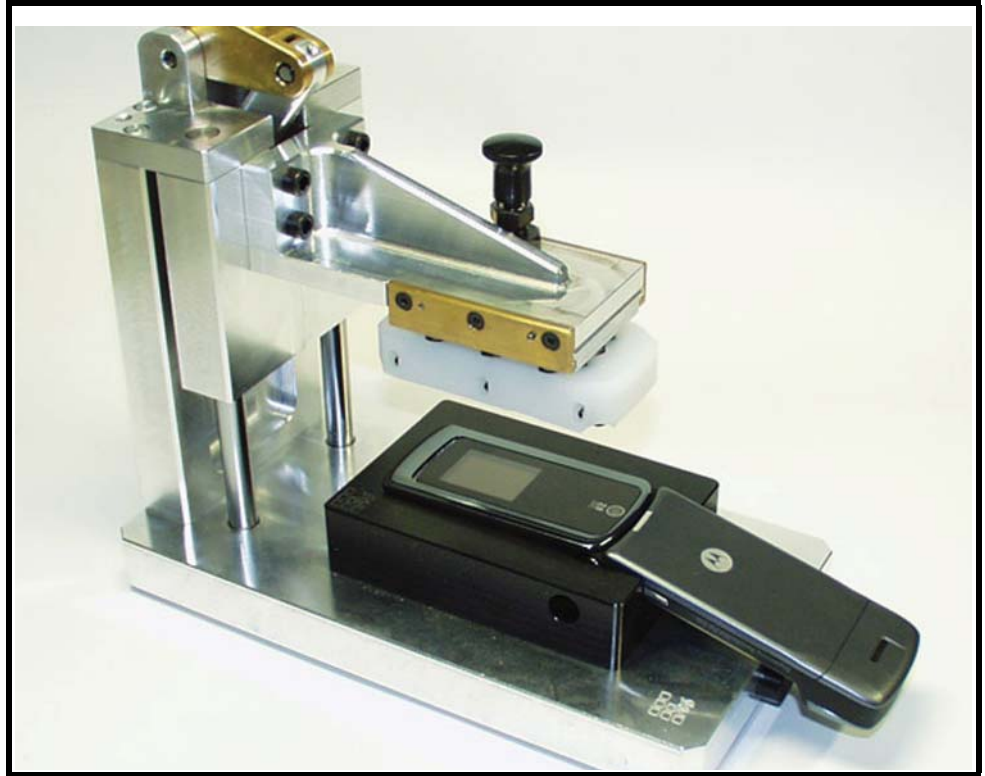

070213o

Figure 37. K3 Lens Press Fixture

3. Start the press process for at least 8 seconds.

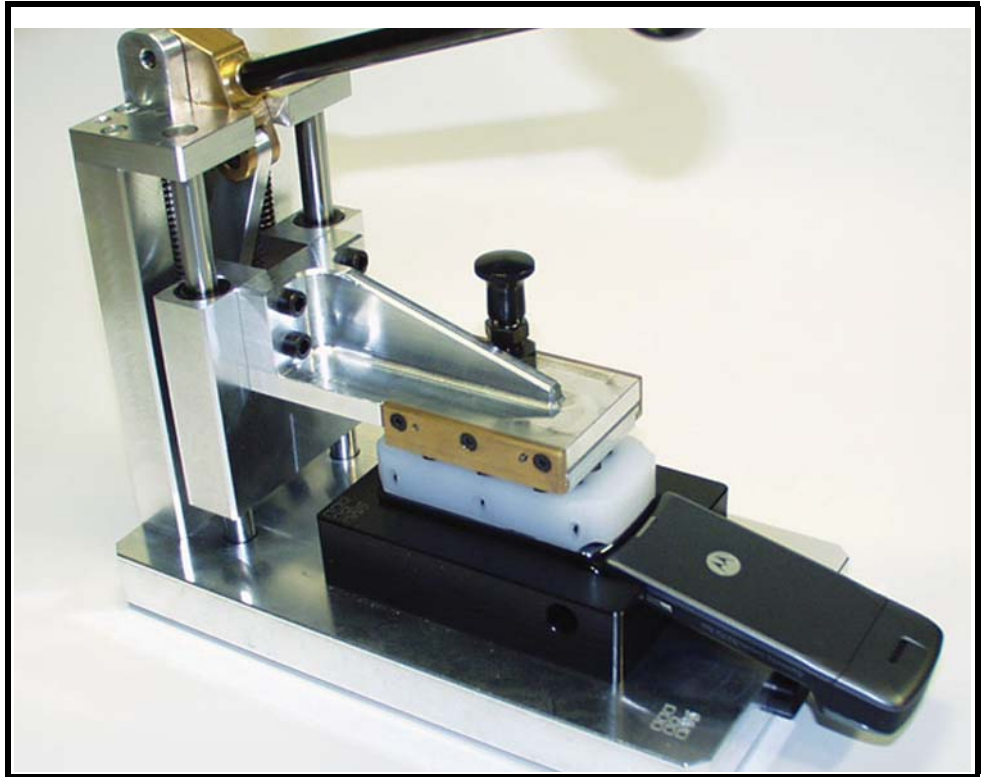

0702160

Figure 38. K3 Lens Press Fixture Closed

4. Open the press fixture and check the flip assembly.
5. Replace the transceiver board, rear housing, SIM, battery and battery cover as described in the procedures.

Subscriber Identity Module (SIM) and Identification

USIM Card

A USIM is required to access the existing local GSM network, or remote networks when traveling (if a roaming agreement has been made with the provider).

The SIM contains:

- All the data necessary to access GSM services.
- The ability to store user information such as, phone numbers.
- All information required by the network provider to provide access to the network.

Personality Transfer

A personality transfer is required when a phone is express exchanged or when the main board is replaced. Personality transfers reproduce the customer's original personalized details such as, menu and stored memory such as, phone books, or even just program a unit with basic user information such as, language selection. K3 telephones can use Motorola mobile Phone Tools software to effect a personality transfer.

Identification

Each Motorola UMTS device is labeled with a variety of identifying numbers. The following information describes the current identifying labels.

Mechanical Serial Number (MSN)

The Mechanical Serial Number (MSN) is an individual unit identity number and remains with the unit throughout the life of the unit.

The MSN can be used to log and track a unit on Motorola's Service Center Database. The MSN is divided into 4 sections, as shown in Figure 39.

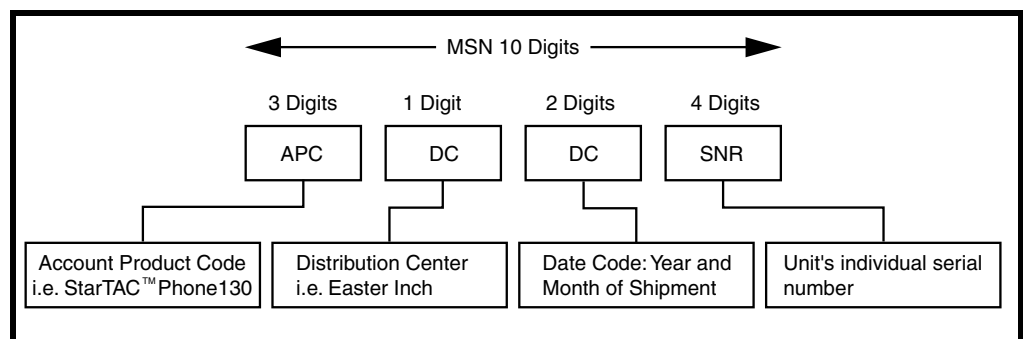

000807a

Figure 39. MSN Label breakdown

International Mobile Station Equipment Identity (IMEI)

The International Mobile station Equipment Identity (IMEI) number is an individual number unique to the PCB and is stored within the unit's memory.

The IMEI uniquely identifies an individual mobile station and thereby provides a means for controlling access to GSM networks based on mobile station types or individual units. The full IMEI structure is listed in Table 2.

Table 2. IMEI Number Breakdown

TAC	Serial Number	Check Digit
NNXXXXXX	ZZZZZZ	A

Where

TAC Type Allocation Code, formerly known as Type Approval Code

NN Reporting body identifier

XXXXXX Type Identifier

ZZZZZZ Individual unit serial number

A Phase 1 = 0.

Phase 2 = check digit defined as a function of all other IMEI digits

Other label number configurations present are:

- **TRANSCIVER NUMBER:** Identifies the product type. Normally the SWF number. (i.e. V100).
- **PACKAGE NUMBER:** Identifies the equipment type, mode, and language in which the product is shipped.

Troubleshooting

Manual Test Mode

Motorola K3 telephones are equipped with a manual test mode capability. This allows service personnel to verify functionality and perform fault isolation by entering keypad commands.

To enter the manual test command mode, a GSM / DCS test SIM must be used.

1. Press **Ⓞ** to turn the phone OFF.
2. Remove the battery as described in the procedures.
3. Remove the customer's SIM card from the phone as described in the procedures.
4. Insert the test SIM into the SIM slot.
5. Replace the battery as described in the procedures.
6. Press **Ⓞ** to turn the phone ON.

Manual Test Mode Commands

Table 3. Manual Test Commands

Key Sequence	Test Function/Name	Remarks
<Menu>048263*	Enter manual test mode	
"End" Key	Exit manual test mode	
54*	Suspend	Required for all Test Mode Operations
0*0*0	Select tone 0	
0*0*1	Select tone 1	
0*0*2	Select tone 2	
0*0*3	Select tone 3	
0*0*4	Select tone 4	
0*0*5	Select tone 5	
0*0*6	Select tone 6	
0*0*7	Select tone 7	
0*0*8	Select tone 8	
0*0*9	Select tone 9	
0*1*X	Disable tone X	
3*0*1	Enable vibrator	
3*0*0	Disable vibrator	
5*0*0	Set audio level 0	
5*0*1	Set audio level 1	
5*0*2	Set audio level 2	
5*0*3	Set audio level 3	
5*0*4	Set audio level 4	
5*0*5	Set audio level 5	
5*0*6	Set audio level 6	
5*0*7	Set audio level 7	
5*0*8	Set audio level 8	
5*0*9	Set audio level 9	
5*0*10	Set audio level 10	
5*0*11	Set audio level 11	
5*0*12	Set audio level 12	
5*0*13	Set audio level 13	
5*0*14	Set audio level 14	
5*0*15	Set audio level 15	
6*2*2*0*0	Set Audio Path. Int Mic, IntSpk, RX unmute, TX unmute	
6*4*6*0*0	Set Audio Path. Boom Mic, Boom Spk, RX unmute, TX unmute	
10*0*3	Set band GSM 900	
10*0*4	Set band DCS 1800	
10*0*5		
10*0*6	Set dual band GSM 900 / 1800	
10*1*0	Read band	3= GSM 4= DCS 5= PCS 6 =GSM/DCS

Table 3. Manual Test Commands (Continued)

Key Sequence	Test Function/Name	Remarks
18*0	Initialize non-volatile memory (Master Reset)	
18*1	Initialize non-volatile memory (Master Clear)	
55*2*001	Test Display. All pixels ON	
55*2*000	Test Display. All pixels OFF	
55*2*002	Test Display. Checkerboard pattern A	
55*2*003	Test Display. Checkerboard pattern B	
55*2*004	Test Display. Border pixels ON	
*#06#	IMEI Check	No Test Mode Required
Phone Set up --> Phone Status --> Other Information	Flex Version / Technology / S-W Version / Readiness Status	No Test Mode Required

Troubleshooting Chart

Table 4. Level 1 and 2 Troubleshooting Chart

SYMPTOM	PROBABLE CAUSE	VERIFICATION AND REMEDY
1. Telephone will not turn on or stay on.	a) Battery either discharged or defective.	Measure battery voltage across a 50 ohm (>1 Watt) load. If the battery voltage is <3.25 Vdc, recharge the battery using the appropriate battery charger. If the battery will not recharge, replace the battery. If battery is not at fault, proceed to b.
	b) Battery connectors open or misaligned.	Visually inspect the battery connectors on both the battery and the telephone. Realign and, if necessary, either replace the battery or refer to a Level 3 Service Center for the battery connector replacement. If battery connectors are not at fault, proceed to c.
	c) Transceiver board assembly defective.	Refer service to authorized Level 3 service center for replacement.
2. Telephone exhibits poor reception or erratic operation such as, calls frequently dropping or weak or distorted audio.	a) Antenna assembly defective.	Check to make sure that the antenna pin is properly connected to the transceiver board assembly. If connected properly, substitute a known good antenna. If the fault is still present, proceed to b.
	b) Transceiver board assembly defective.	Refer service to authorized Level 3 service center for replacement.
3. Display is erratic, or provides partial or no display.	a) Transceiver board connections faulty.	Remove rear chassis assembly from unit, check general condition of flexible printed cable (flex). If the flex is good, check that the flex connector is fully seated. If not, check connector to transceiver board connections. If faulty connector, Refer service to authorized Level 3 service center for replacement. If connector is not at fault, proceed to b.
	b) Flip assembly defective.	Temporarily replace the flip assembly with a known good assembly. If fault has been cleared, reassemble with the new flip assembly. If fault not cleared, proceed to c.
	a) Transceiver board assembly defective.	Refer service to authorized Level 3 service center for replacement.
4. Incoming call alert transducer audio distorted or volume is too low.	a) Audio transducer damaged.	Replace the audio transducer. Verify that the fault has been cleared and reassemble the unit with the new audio transducer. If fault not cleared, proceed to b.
	b) Faulty transceiver board assembly.	Refer service to authorized Level 3 service center for replacement.
5. Telephone transmit audio is weak. (usually indicated by called parties complaining of difficulty in hearing voice).	a) Transceiver board assembly defective.	Refer service to authorized Level 3 service center for replacement.
6. Receive audio from earpiece speaker is weak or distorted.	a) Connections to or from transceiver board assembly defective.	Gain access to the transceiver board assembly as described in the procedures. Check flex and the flex connector from the flip assembly to the transceiver board assembly. If flex is at fault, replace flip assembly. If flex connector is at fault, proceed to d. If connection is not at fault, proceed to b.

Table 4. Level 1 and 2 Troubleshooting Chart (Continued)

SYMPTOM	PROBABLE CAUSE	VERIFICATION AND REMEDY
	b) Flip assembly defective.	Temporarily replace the flip assembly with a known good assembly. If fault has been cleared, reassemble with the new flip assembly. If fault not cleared, proceed to c.
	c) Antenna assembly defective.	Check to make sure the antenna is installed correctly. If the antenna is installed correctly, substitute a known good antenna assembly. If this does not clear the fault, reinstall the original antenna assembly and proceed to d.
	d) Transceiver board assembly defective.	Refer service to authorized Level 3 service center for replacement.
7. Telephone will not recognize or accept SIM.	a) SIM defective.	Check the SIM contacts for dirt. Clean if necessary and check if fault has been cleared. If the contacts are clean, insert a known good SIM into the telephone. Power up the unit and confirm that the SIM has been accepted. If the fault no longer exists, replace the defective SIM. If the SIM is not at fault, proceed to b.
	b) Daughter board assembly defective.	Temporarily replace the daughter board assembly with a known good assembly. If fault has been cleared, reassemble with the new daughter board assembly. If fault not cleared, proceed to c.
	c) Transceiver board assembly defective.	Refer service to authorized Level 3 service center for replacement.
8. Phone does not sense when flip is opened or closed (usually indicated by inability to answer incoming calls by opening the flip, or inability to make outgoing calls).	a) Flip assembly defective.	Temporarily replace the flip assembly with a known good assembly. If fault has been cleared, reassemble with the new flip assembly. If fault not cleared, proceed to b.
	b) Transceiver board assembly defective.	Refer service to authorized Level 3 service center for replacement.
9. Vibrator feature not functioning.	Transceiver board assembly defective.	Refer service to authorized Level 3 service center for replacement.
10. Internal Charger not working.	Faulty charger circuit on transceiver board assembly.	Test a selection of batteries in the rear pocket of the desktop charger. Check main display for the charging indications. If these are charging properly, then the internal charger is at fault. Refer service to authorized Level 3 service center for replacement.
11. Real Time Clock resets when battery is removed.	Lithium button cell on the transceiver board may be depleted.	Refer service to a Level 3 service center for replacement.

Programming: Software Upgrade and Flexing

Contact your local technical support engineer for information about equipment and procedures for flashing and flexing.

Part Numbers

The following information is provided as a reference for the parts associated with K3 telephones.

Exploded View Diagram

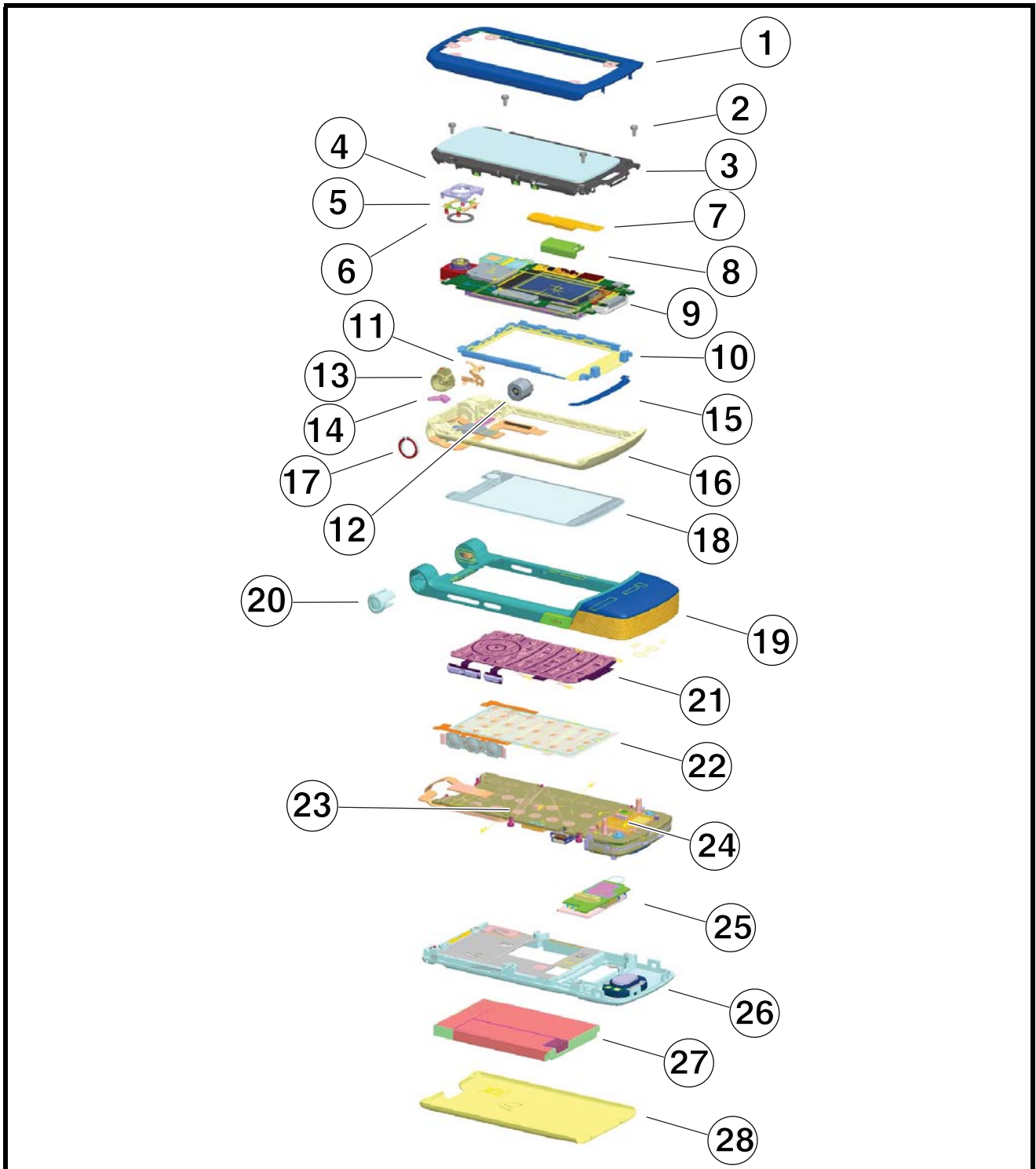

070144o

Figure 40. Exploded View Diagram

Exploded View Parts List

The following part number table is provided only for reference. Please contact your local Motorola parts organization for current part number information.

Table 5. Exploded View Parts List

Item Number	Motorola Part Number	Description
1	0103501Pnn	Flip outer assembly
2	0387473K10	5IP Flip housing screw (x4)
3	0103502Pnn	Flip chassis assembly
4	1503579B12	2 Mpixel camera holder
5	3903537C13	2 Mpixel grounding bracket
6	3203571B60	2 Mpixel gasket
7	0503578C11	CLI display rubber
8	0503578C13	Main display rubber
9	CFLG103AA	Flip PCB assembly
10	1503579C12	Display guide
11	390353C12	Flip hinge grounding
12	5571836E01	Hinge
13	0503578C17	Flex plug
14	3203571B59	Inner slot gasket
15	3503551B19	Front earpiece felt
16	1503651Enn	Flip inner housing

Item Number	Motorola Part Number	Description
17	4303646D09	Shaft sleeve
18	6103652Enn	Main display lens
19	0103503Pnn	Front housing assembly
20	1503672E01	Shaft flex end cap
21	3803687Enn	Keypad
22	4003690E01	Dome and EL array
23	CFLG1032AA	Main PCB assembly
24	0103683E01	Antenna module
25	0103561B42	Daughter PCB
26	0103679Enn	Rear housing assembly
27	0189054P03	Battery PF4 limited 850 mAh
28	1503653E00	Battery door



There is a danger of explosion if the Lithium ion battery pack is replaced incorrectly. Replace only with the same type of battery or equivalent as recommended by the battery manufacturer. Dispose of used batteries according to the manufacturer's instructions.

For information on ordering parts please contact EMEA at + 49 461 803 1404.

Accessories

Table 6. Accessories

Part Description	Part Number
Power Solutions	
Battery-Only-Charger - Razor K3, South Asia plug	CHPN4613A
Right Angle Dongle (EMU)	SKN6182
Travel Charger EMU Mid-Rate Switcher - Argentina	SPN5192
Travel Charger EMU Mid-Rate Switcher - Australia	SPN5193
Travel Charger EMU Mid-Rate Switcher - BRAZIL	SPN5187
Travel Charger EMU Mid-Rate Switcher - EURO	SPN5189
Travel Charger EMU Mid-Rate Switcher - INDIA	SPN5194
Travel Charger EMU Mid-Rate Switcher - MEXICO	SPN5186
Travel Charger EMU Mid-Rate Switcher - PRC	SPN5188
Travel Charger EMU Mid-Rate Switcher - TWN	SPN5216
Travel Charger EMU Mid-Rate Switcher - UK/HK	SPN5190
Travel Charger EMU Mid-Rate Switcher - US ENG	SPN5185
Travel Charger EMU Rapid Switcher - Argentina	SPN5197
Travel Charger EMU Rapid Switcher - BRAZIL	SPN5196
Travel Charger EMU Rapid Switcher - HK	SPN5199
Travel Charger EMU Rapid Switcher - MEXICO	SPN5200
Travel Charger EMU Rapid Switcher - PRC	SPN5198
Travel Charger EMU Rapid Switcher - US	SPN5202
Travel Charger EMU Rapid TWN	SPN5270
Charger Adapter - Aust/NZ Plug	SYN8127
Charger Adapter - Euro Plug	SYN7456
Charger Adapter - UK Plug	SYN7455
Charger Adapter EMU/EMU (Y-cable)	skn6222
In Vehicle Solutions	
Self Install Car Kit Universal - Mandarin - Smart Drive+	SYN0888
Self Install Car Kit Universal - Smart Car Kit - Smart Drive	SYN0890
Smart Cable EMU - Motorola	SYN1003
Vehicle Power Adapter EMU - VC700	SYN0847
Audio and Connectivity	
Stereo Headset - EMU	SYN1301
Data Cable Mini USB/USB/Serial	SKN6371
Headset Mono One Touch w/ Send-End (EMU)	SYN0896
Bluetooth Products	
H500 Gloss Black	SYN1375
H500 Nickel Japan	SYN1441
H500 Pink	SYN1436
Bluetooth Class 1 USB Adapter PC850	SYN1244
H500 Bluetooth headset Black Soft touch	SYN1374
H500 Bluetooth Headset Hot Pink	SYN1525

Table 6. Accessories (Continued)

Part Description	Part Number
H500 Bluetooth Headset iPod Blue	SYN1523
H500 Bluetooth Headset iPod Gold	SYN1524
H500 Bluetooth Headset Spa Blue	SYN1527
H500 Bluetooth Headset White	SYN1526
Bluetooth Car Kit - Asia/Americas	S9642
Bluetooth Car Kit - Euro	S9643
Bluetooth Car Kit - HF850	SJ0014
Bluetooth Car Kit - IHF1000 - Americas/Asia	98676H
Bluetooth Car Kit - IHF1000 - EMEA	CFLN1232
Bluetooth Headset - Glossy Black - HS820	SYN9951
Bluetooth Headset - Green - HS820	SYN0945
Bluetooth Headset - Grey - HS820	SYN1106
Bluetooth Headset - HS850 (Paladin Refresh - Black)	SYN1107
Bluetooth Headset - HS850 (Paladin Refresh - Blue)	SYN1226
Bluetooth Headset - Oakley RAZRWIRE (Mercury: NA) - H7	98679H
Bluetooth Headset - Oakley RAZRWIRE (Pewter/Black: NA) - H7	98677H
Bluetooth Headset - Oakley RAZRWIRE (Platinum/Rootbeer: NA) - H7	98678H
Bluetooth Headset (Aphrodite) - H700	SYN1311
Bluetooth Headset (Genie Gray) - HS801	CHYN4590AB
Bluetooth Headset (Genie Pink) - HS801	CHYN4590AC
Bluetooth Headset (Genie Refresh - Dk Blue) - HS815	SYN1201
Bluetooth Headset (Genie Silver) - HS801	CHYN4590
Bluetooth Headset (Mage) - HS830	SYN0996
Bluetooth Headset (Medusa - Pearl Dark Gray) - H300	SYN1297
Bluetooth Headset (Medusa - Pink) - H300	SYN1417
Bluetooth Headset (Medusa - Pure White) - H300	SYN1416
Bluetooth Headset (Nexus) - HS805	SYN0986
Bluetooth Headset (Paladin) - HS810	SYN9826
Bluetooth Headset (Persephone) - H605	SYN1303
Bluetooth Helmet Headset - HS830 (Mage)	SYN0997
Bluetooth Mono Headset, Nickel- H500	SYN1290
Bluetooth PC USB Adapter	SYN0717
Bluetooth Speaker (Quadrant Refresh) - HF820	SYN0736C

A

active line indicator 16
alert settings 16
antenna assembly, removing and replacing 30

B

battery
 function 16
 gauge 16
 removing 20
battery door
 removing 20
battery indicator 16

C

call divert indicator 16
caller ID 13
camera assembly, removing and replacing 40, 41
Canadian Interference-Causing Equipment regulations 5
changes
 product 5
CLI and Main Display Lens, removing and replacing 49
commands, manual test mode 55
conventions 7
copyrights
 computer software 6

D

data indicator 15
daughter board assembly, removing and replacing 28
disassembly 20
display module assembly, removing and replacing 38

E

EDGE indicator 15
exploded view diagram 59
exploded view parts list 60

F

FCC rules 5
features
 caller ID 13
 SIM Toolkit 12
 text entry 12
 Wireless Access Protocol (WAP) 12
features, product 11
flip assembly, removing and replacing 36
Flip Hinge and Flex assembly, removing and replacing 42

G

GPRS indicator 15

I

identification 52
 international mobile station equipment identity 53
 mechanical serial number 52
 product 5
IMEI 53
in-call indicator 16
Introduction 5

K

keypad, removing and replacing 29

L

Low Battery message 16

M

manual test mode 54
message indicator 16
MSN 52

N

names
 product 5

O

operation
 controls, indicators, and I/O 14
operation, general 14
overview, product 11

P

part numbers
 accessories 60
parts 58
 exploded view diagram 59
 exploded view parts list 60
product
 changes 5
 identification 5
 names 5

R

rear housing

- removing 24
- regulatory agency compliance 5
- removing
 - antenna assembly 30
 - battery 17, 20
 - battery door 20
 - camera assembly 40, 41
 - CLI and Main Display Lens 49
 - daughter board assembly 28
 - display module assembly cover 38
 - flip assembly 36
 - Flip Hinge and Flex assembly 42
 - keypad 29
 - rear housing 24
 - SIM 23
 - transceiver board assembly 26
 - TransFlash Memory Module 22
- replacement parts
 - contact information 8
- replacing
 - antenna assembly 30
 - battery 20
 - camera assembly 40, 41
 - CLI and Main Display Lens 49
 - daughter board assembly 28
 - display module assembly 38
 - flip assembly 36
 - Flip Hinge and Flex assembly 42
 - keypad 29
 - rear housing 24
 - SIM 23
 - transceiver board assembly 26
 - TransFlash Memory Module 22
- ring style indicator 16
- roam indicator 16

S

- serial number
 - mechanical 52
- service manual
 - about 6
 - revisions 7
 - scope 6
- service policy 7
 - customer support 7
 - out of box failure 7
 - product support 7
- service procedure
 - ordering replacement parts 8
- shut down

- upon battery removal 17
- signal strength indicator 15
- SIM Application Toolkit 12
- SIM card 52
 - personality transfer 52
 - replacing 23
- SIM, removing and replacing 23
- support
 - customer 7
 - product 7

T

- text entry 12
- tools and test equipment 19
- transceiver board assembly, removing and replacing 26
- TransFlash Memory Module, removing and replacing 22
- troubleshooting 54
 - manual test mode 54
 - manual test mode commands 55

V

- voice commands 12
- voicemail message indicator 16

W

- warranty service 7
- wireless access protocol (WAP) 12