

DUAL BAND ZAP AUDIO LOGIC BLOCK DIAGRAM

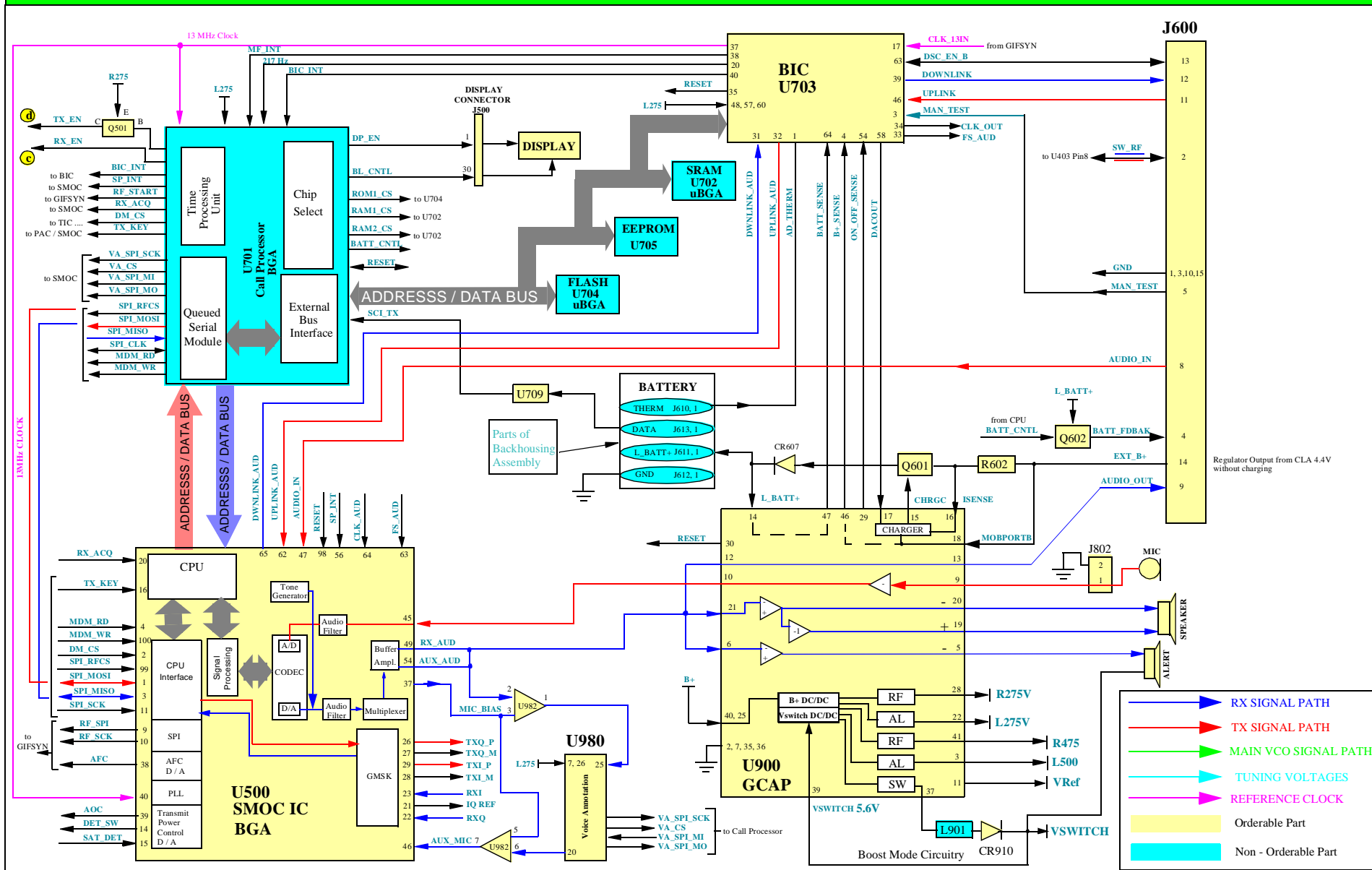

LOGIC BOARD SIGNALS

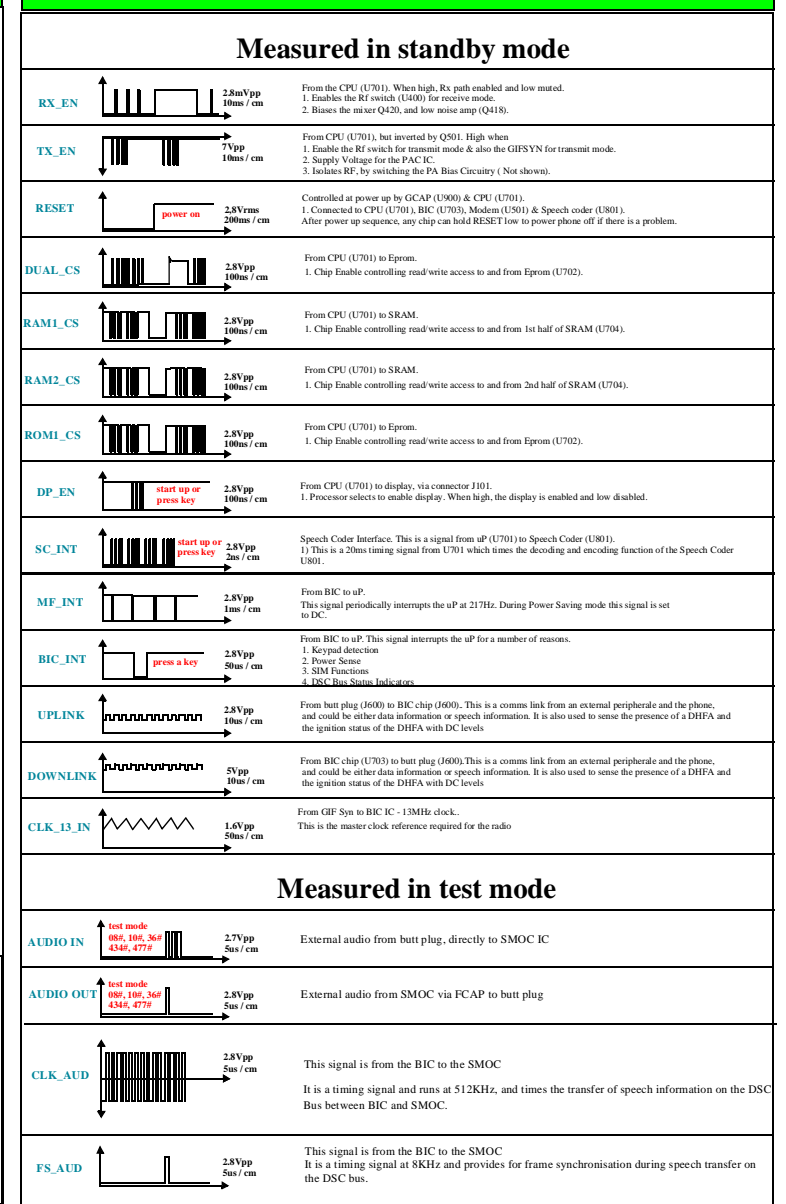

AL LAYER - ORDERABLE SPARES

Part Designator	Part Description	Part Number	Part Designator	Part Description	Part Number
Alert	Alert	5009005J03	Q601	Power Transistor Charging	4809579E04
BT700	Connector Real Time Clock	0909888M01	Q602	Transistor Battery Feedback	4809937C05
CR607	Diode Charge Line	4809606E07	R602	Resistor I Sense	0680195M64
CR910	Diode Switched Supply	4809653F02	U500	SMOC IC	5199332C04
J500	Keyboard Connector	2809424M01	U703	BIC IC	5109962C11
J600	Connector-Extern	0909449B03	U900	GCAP	5109632D75
J603	Connector Vibra	0909888M01	U980	Voice Annotation IC	5109152M07
J802	Connector Microphone	0909195E01	U982	Amplifier IC	5109731C03
J803	Connector Speaker	0909888M04	SH11	Shield Call Processor	2609482M01
J900	SIM Connector	3909426M01	SH12	Shield GCAP	2609481M01
LS802	Speaker	5009076E12	SH13	Shield SMOC	2609483M01
Mic	Microphone	5009536H15	SH14	Shield BIC / EEPROM	2609484M01
Q501	Transistor TX_EN	4809607E05			

TEST COMMANDS

# press 2 sec.	Enter Manual Test Mode
01 #	Exit Manual Test Mode
07 #	Mute Rx Audio Path
08 #	Unmute Rx Audio Path
09 #	Mute Tx Audio Path
10 #	Unmute Tx Audio Path
11xxxx #	Program Main Local Osc. to Channelbb
12xx #	Set Tx Power level to fixed valure
19 #	Display SW Version Number of Call Processor
20 #	Display SW Version Number of Modem
22 #	Display SW Version Number of Speech Coder
25 #	Set Continuous AGC
26xxxx #	Set Continuous AFC
31x #	Initiate Pseudo-Random Sequence with Midamble
33xxxx #	Synchronize to BCH Carrier
36 #	Initiate Acoustic Loopback
37 #	Stop Test
45xxxx #	Serving Cell Power Level
46 #	Display Current Value od AFC DAC
47x #	Set Audio Volume
58 / xxxxxx #	Display / Modify Security Code
59 / xxx #	Display / Modify Lock Code
60 #	Display IMEI
7100 #	Display Error Code

POWER UP DEBUG

Tie watchdog as shown in Signal Flow diagram, and supply power to radio:

- Check that there is B+ present at input to GCAP on pin 40. If not, could be problem with Battery Select Circuitry (Q906)
- GCAP should then drive R275, L275 and VRef. If these are not present, could be a problem with GCAP itself.
- Verify collectors of regulators Q221 and Q222 are both around 2.75V.
- If ok, then check that the SMOC drives the Xtal Varactor Diode CR201 on the AFC line with a DC Voltage.
- If ok, then follow 13MHz path through GIF SYN & BIC and then to Call Processor and SMOC.
- If ok, then check chip enables from Eprom, and SRams at Test Points.
- If ok, then verify Reset Line.

COMMON PROBLEMS

Customer Complaints	Special Note	Part	Prefix	Reason

REVISIONS

Europe Middle East & Africa Customer Services	20.03.98
LEVEL 3 COLOUR DIAGRAMS	Rev. 1.0
Dual Band ZAP	
Colin Jack, Michael Hansen, Billy Jenkins	Page 1 of 2

Europe, Middle East & Africa
Customer Services
Level 3 Authorised

DUAL BAND ZAP RF BLOCK DIAGRAM

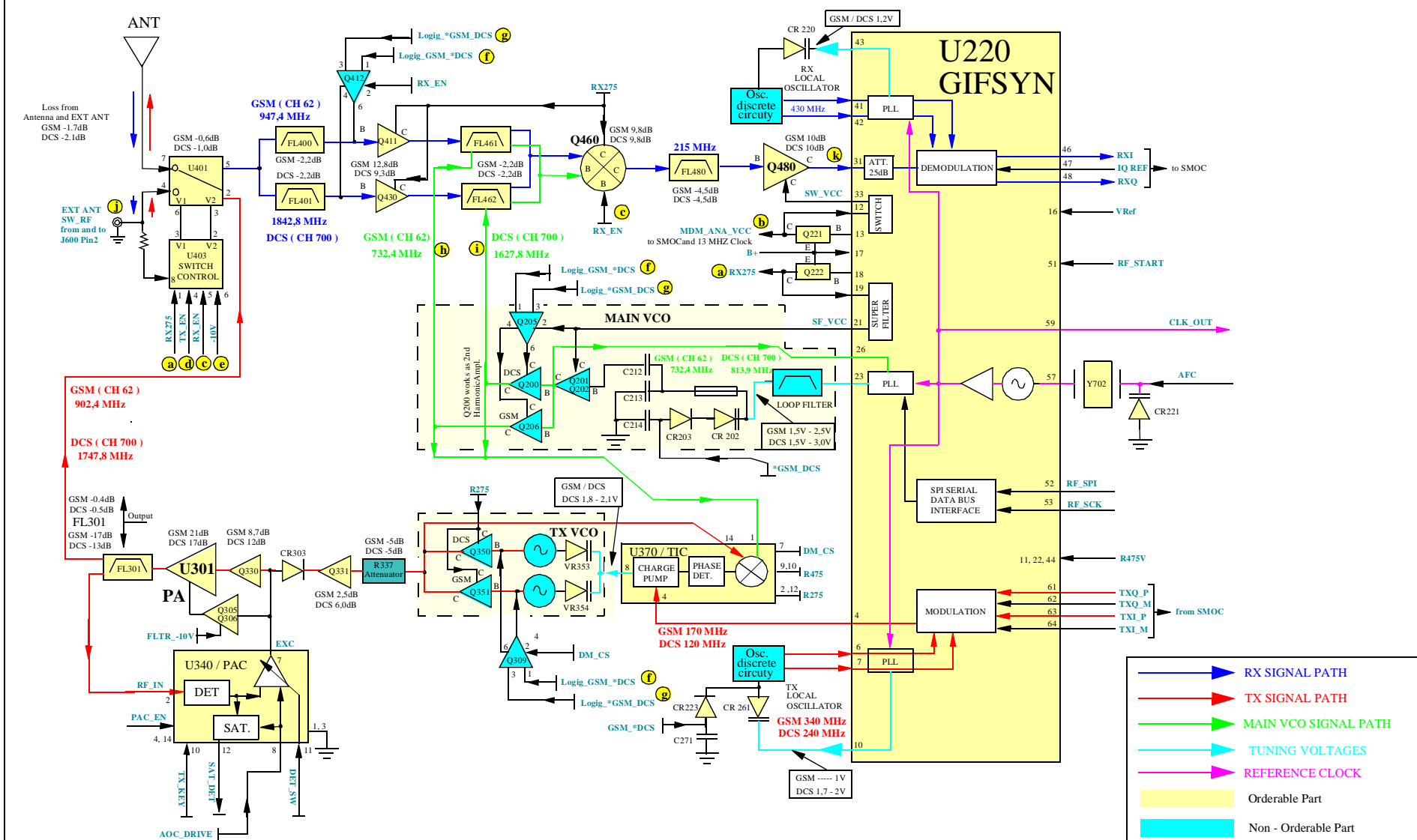

RF BOARD SIGNALS

Tx SIGNALS - 110062#, 1215#, 310# Frequency 217Hz - 1ms/cm

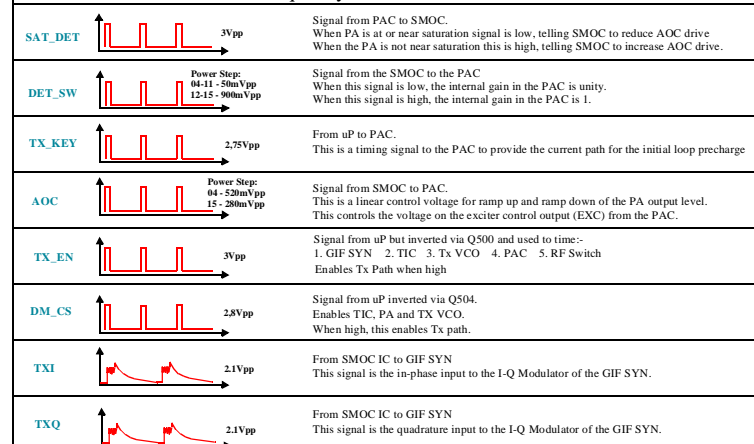

Modem Callprocessor Interface

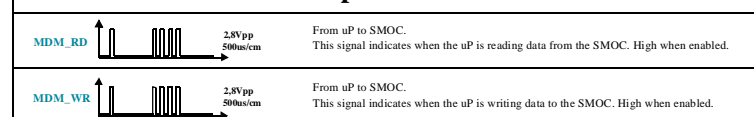

Rx SIGNALS - In Standby Mode

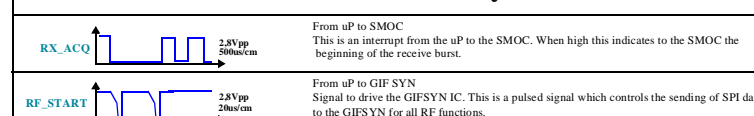

Rx SIGNALS - 110062#, 262000#, 25013#, 241# Frequency 217Hz - 1ms/cm

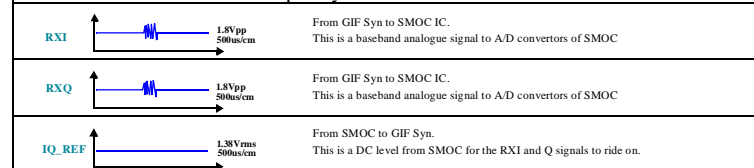

RF LAYER - ORDERABLE SPARES

Designator	Description	Number	Designator	Description	Number
A1	Antenna Connector	3909155T01	Q350-351	TX VCO Transistor	4809940E01
CR202	Main VCO Varactor	4809641F02	Q411	Receive Power Transistor	4809527E24
CR203	Main VCO Diode	4809948D10	Q412	GSM / DCS Switch	4809939C07
CR220	RX Local Osc. Varactor	4809641F02	Q430	Receive Power Transistor	4809527E32
CR221	Master Xtal Varactor	4809641F04	Q460	Receive Mixer Transistor	4809527E20
CR223	Tx Local Osc. Diode	4809948D05	Q480	IF Isolation Amplifier	4809940E01
CR261	Tx Local Osc. Varactor	4809641F02	U220	GIFSYN IC	5109632D92
CR303	TX Exciter Diode	4809948D10	U401	Antenna Switch IC	5109572E04
FL301	1st Rx Filter	9109193T03	U403	Switch Control	5109923D14
FL400	2nd Rx Filter	9109144M01	U301	PA Dual FET IC	4809527E31
FL401	VCO Filter	9109111C08	U370	TIC IC	5109879E12
FL480	IF Saw Filter	9109035M01	U340	PAC IC	5109632D91
FL461	EXT Antenna Connector	9109157M01	VR353	TX VCO Varactor	4809877C06
FL462	GIF SYN Power Transistor	9109429J04	VR354	TX VCO Varactor	4809877C04
Q200	Main VCO Transistor	4809527E30	SH1	Shield Low Noise Ampl.	2609474M01
Q201-202	Main VCO Transistor	4809527E24	SH2	Shield PA	2609475M01
Q205	GSM / DCS Switch	4809937C07	SH3	Shield GIFSYN	2609476M01
Q221-222	Supply Transistor	4809579E18	SH4	Shield Exiter	2609477M01
Q305-306	PAC Transistor	4809939C07	SH5-SH7	Shield VCO TIC	2609480M01
Q309	GSM / DCS Switch	4809939C07	SH8	Shield Mixer Iso Ampl.	2609478M01
Q330	TX Buffer	4809527E26	SH9	Shield Rf Switch	2609479M01
Q331	TX Predriver	4809527E24			

TEST COMMANDS

#	sec.	Enter Manual Test Mode with Test Card
01 #		Exit Manual Test Mode
07 #		Mute Rx Audio Path
08 #		Unmute Rx Audio Path
09 #		Mute Tx Audio Path
10 #		Unmute Tx Audio Path
11 xxx #		Program Main Local Osc. to Channel
12 xx #		Set Tx Power level to fixed value
19 #		Display SW Version Number of Call Processor
20 #		Display SW Version Number of Modem
22 #		Display SW Version Number of Speech Coder
25 #		Set Continuous AGC
26xxxx #		Set Continuous AFC
31x #		Initiate Pseudo-Random Sequence with Midamble
33xxxx #		Synchronize to BCH Carrier
36 #		Initiate Acoustic Loopback
37 #		Stop Test
45xxxx #		Serving Cell Power Level
46 #		Display Current Value of AFC DAC
47x #		Set Audio Volume
58 / xxxxx #		Display / Modify Security Code
59 / xxx #		Display / Modify Lock Code
60 #		Display IMEI
7100 #		Display Error Code

RECEIVE DEBUG - GSM MODE

Before actually removing any cans it may be worth checking the RX275 (a), MDM_ANA_VCC (b), RX_EN (c), -10V (e) and if the Logig_GSM_DCS (f) is high to switch the output of Q412 Pin6 and Q205 Pin4 to high.

TEST MODE: Type in Key commands: 110062#, 262000#, 25013#, 241#. Test for a set level eg. (-30dB's) at point (i) to compensate cable losses.

The only real short-cut we can take is by probing the 215MHz test point (k) (pin 31of GIF).

- If the 215 is OK then we can assume problem lies around GIF: either 430MHz Local Oscillator or in generation of RXI and RXQ. The can SH03 should then be removed. Check that IQ Ref from the SMOC is around 1.38Vdc and then the RXI and Q outputs from the GIF to check which is faulty.
- If the 215MHz is low probe the RF inputs to the Mixer to see which RF path (RF INPUT or MAIN VCO) the fault lies on.
- If Main VCO is low, the main suspects are with the main VCO, or the VCO filter (FL461/462) and the SH07can should be removed.
- If the input to the filter is low, then there is some discretes under the VCO can. Check SF_VCC U220 Pin23 and Main VCO tuning voltage U220 Pin21.
- If RF INPUT, and the MAIN VCO OK, the main suspects are with the 2 input filters FL400 and FL401 and the can SH01 should be removed.
- If the signal is low at the input to these, it could be losses caused by the Antenna Switch U401.
- If 947.4 and 794.4 RF values are fine but 215MHz into GIF is low (k), then we must also remove can SH08. The SAW filter (FL480) and IF Isolation AMP (Q480) is located under here.

FREQUENCIES GSM / DCS

GSM / CHANNEL	Tx	Rx	MAIN VCO	Rx LF	Rx IF LO	Tx LF	Tx IF LO
1-Low	890.2	935.2	782.2	215	430	170	340
62-Middle	902.4	947.4	794.4	215	430	170	340
124-High	914.8	959.8	806.8	215	430	170	340
DCS / CHANNEL	Tx	Rx	MAIN VCO	Rx LF	Rx IF LO	Tx LF	Tx IF LO
1-Low	1710	1805	1590	215	430	120	240
700-Middle	1747.8	1842.8	1627.8	215	430	120	240
124-High	1785	1880	1665	215	430	120	240

REVISIONS

Europe Middle East & Africa Customer Services	20.03.98
LEVEL 3 COLOUR DIAGRAMS	Rev. 1.0
Dual band ZAP	
Colin Jack, Michael Hansen, Billy Jenkins	Page 2 of 2

Europe, Middle East & Africa
Customer Services
Level 3 Authorised