

# Lower Board Schematic

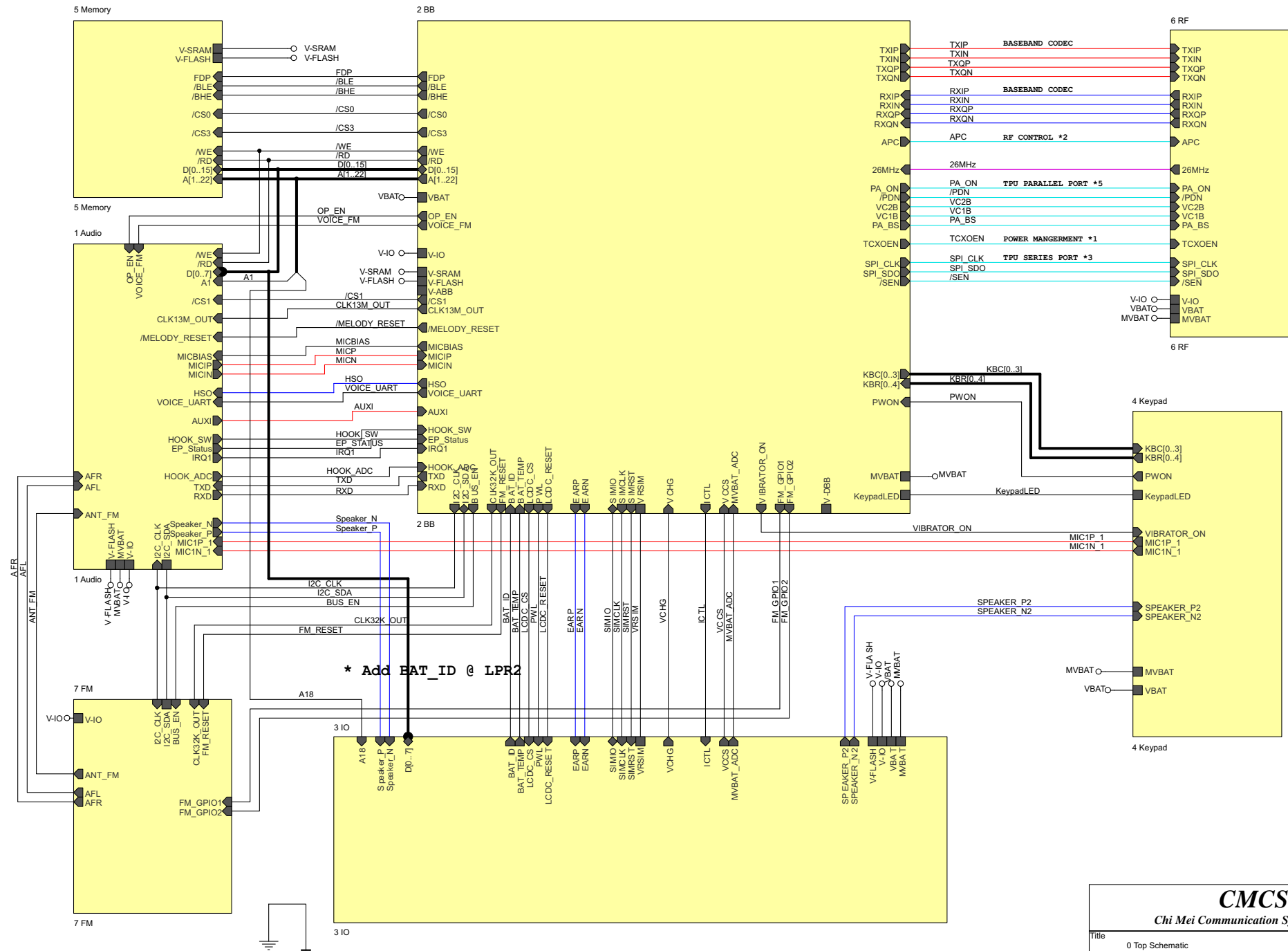

<b>CMCS</b> Chi Mei Communication Systems, Inc.		
Title	0 Top Schematic	
Size	Document Number	Rev
A3	TCLT	0.2
Date:	10月10, 2005	Sheet 18 of

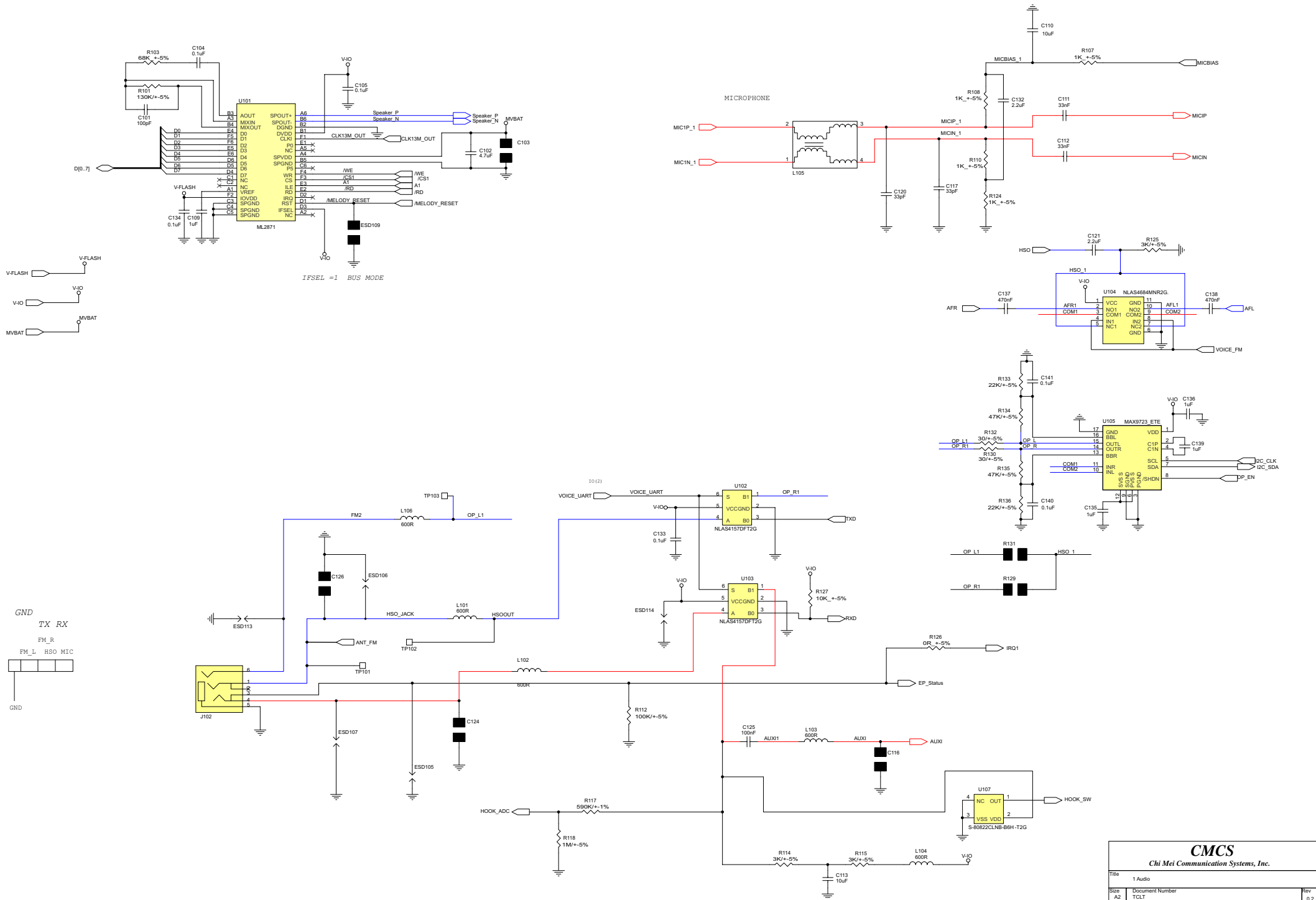

<b>CMCS</b> Chi Mei Communication Systems, Inc.		
Title	1 Audio	
Size	Document Number	Rev
A2	TGLT	0.2
Date	11/10/2005	Sheet 28 of

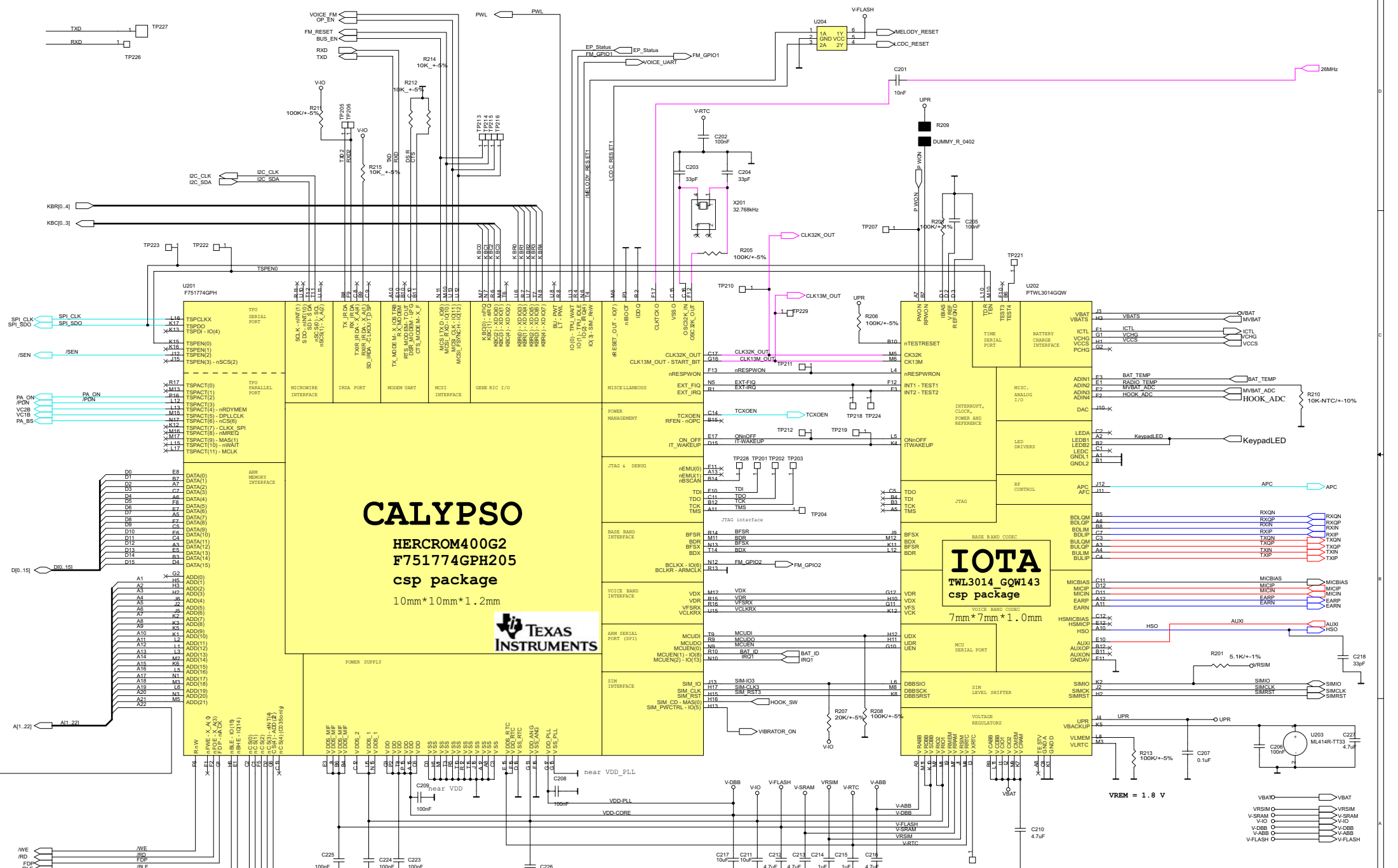

**CALYPSO**  
**HERCROM400G2**  
**F751774GPH205**  
 csp package  
 10mm\*10mm\*1.2mm



**IOTA**  
**TWL3014 GQW143**  
 csp package  
 7mm\*7mm\*1.0mm

<b>CMCS</b> Chi Mei Communication Systems, Inc.		
File	2 B8	
Size	Document Number	Rev 0.2
Date	11/10/2005	Sheet 38 of

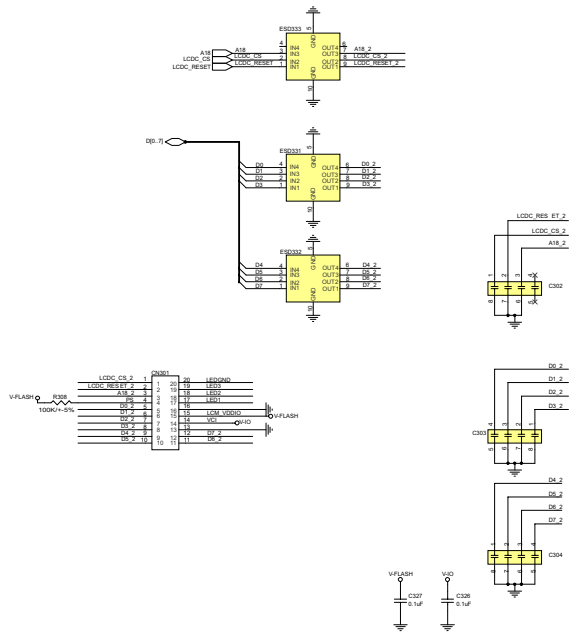

**LCM INTERFACE**

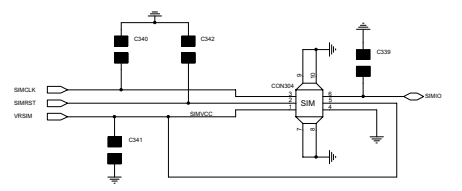

**SIM INTERFACE**

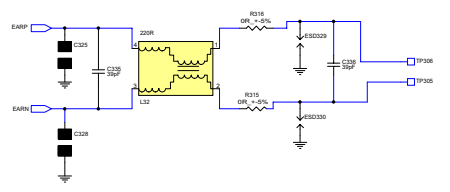

**AUDIO INTERFACE**

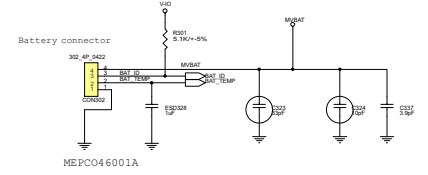

**MEPCO46001A**

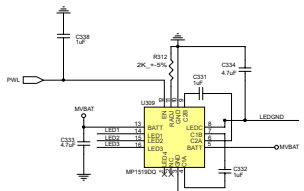
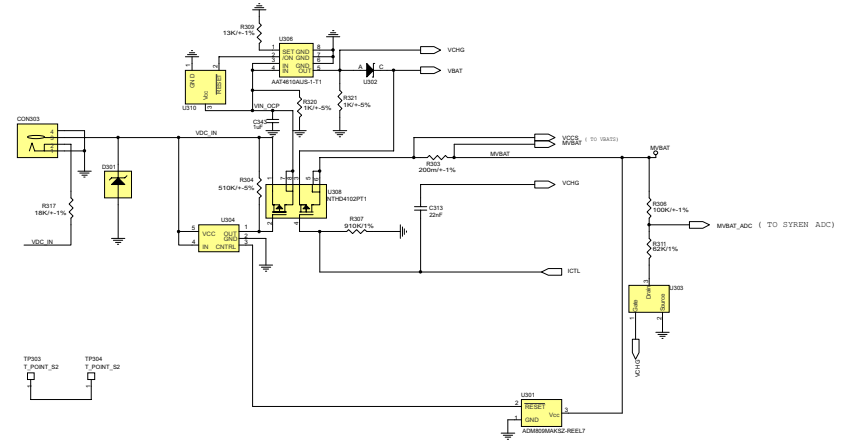

**LED BACKLIGHT DRIVER IC**

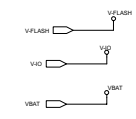

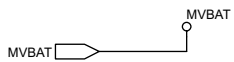
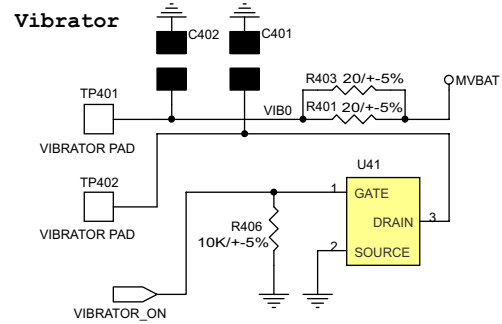
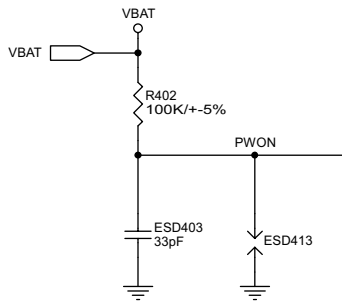
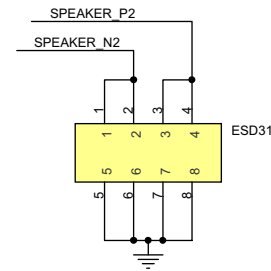
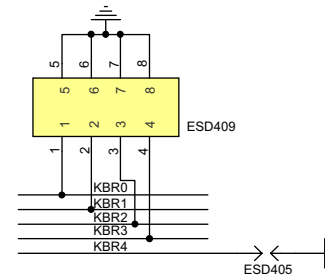
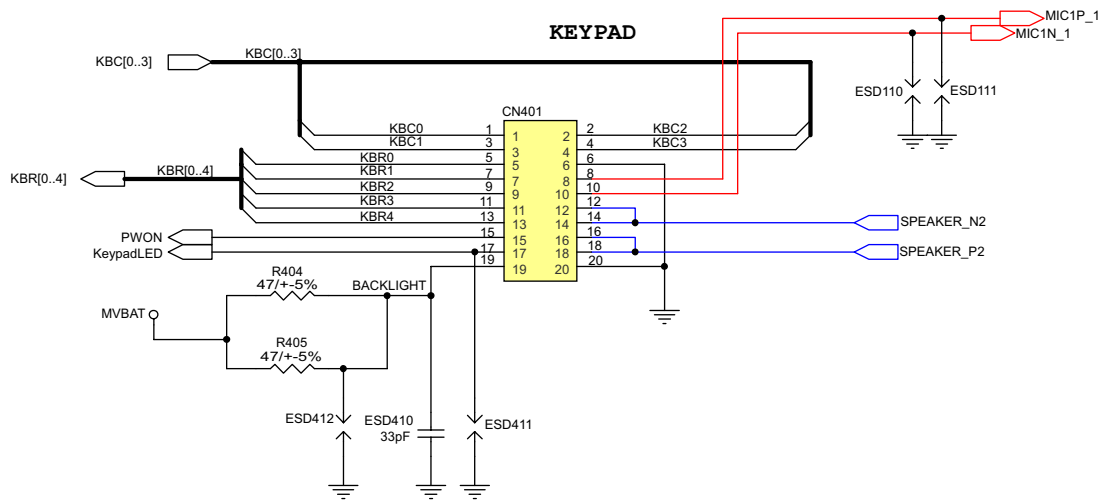

<b>CMCS</b> Chi Mei Communication Systems, Inc.		
Title 4 Keypad		
Size B	Document Number TCLT	Rev 0.2
Date: 星期三, 2005年10月10日	Sheet 58 of 1	

Flash = CS0 ; SRAM = CS3

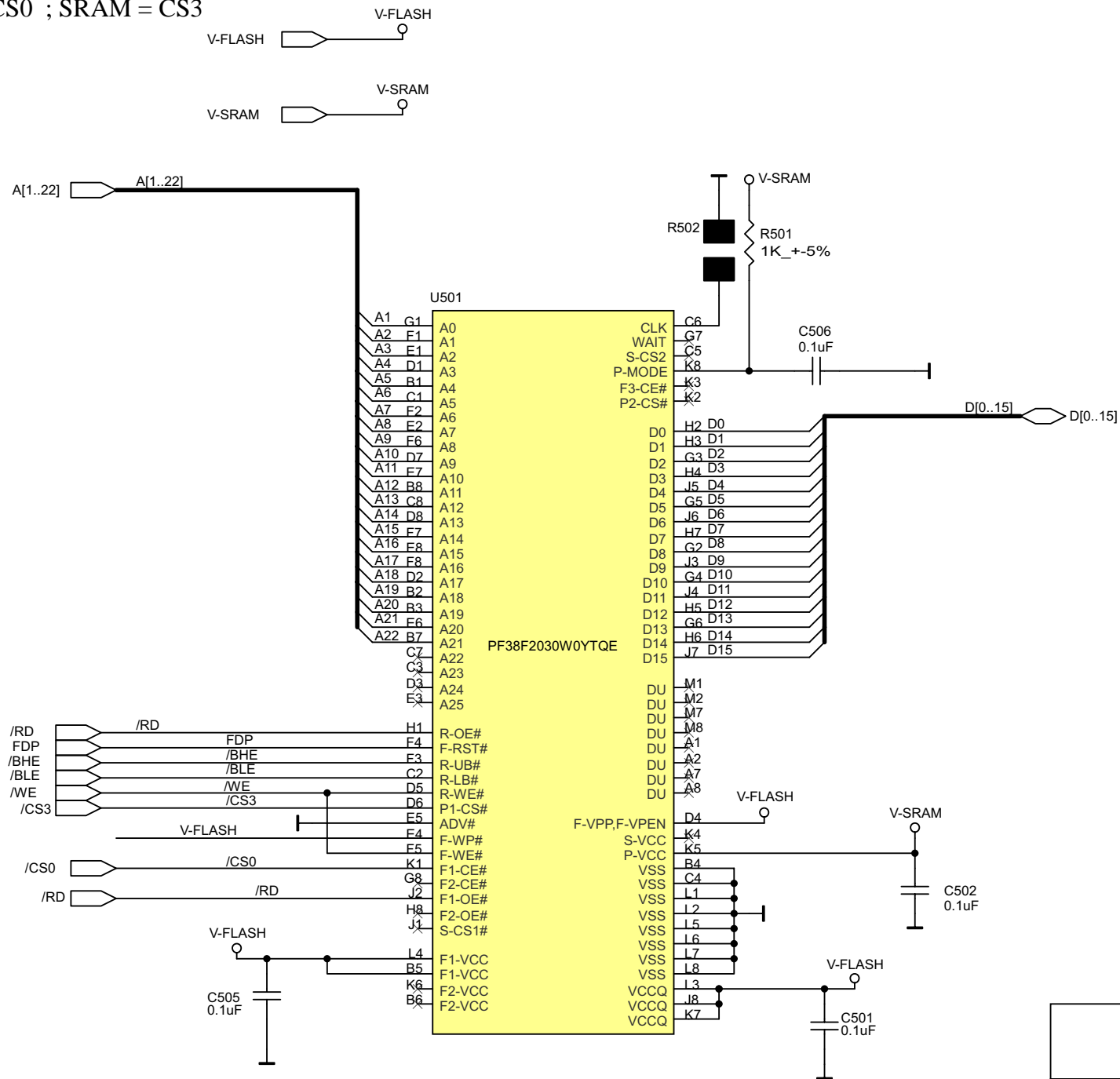

**64Mb NOR Flash + 16 Mbit PSRAM**  
**VIO = VCC = 1.8V**

**CMCS**  
 Chi Mei Communication Systems, Inc.

Title		
5 Memory		
Size	Document Number	Rev
A4	TCLT	0.2
Date:	星期三, 2005年10月10日	Sheet 68 of

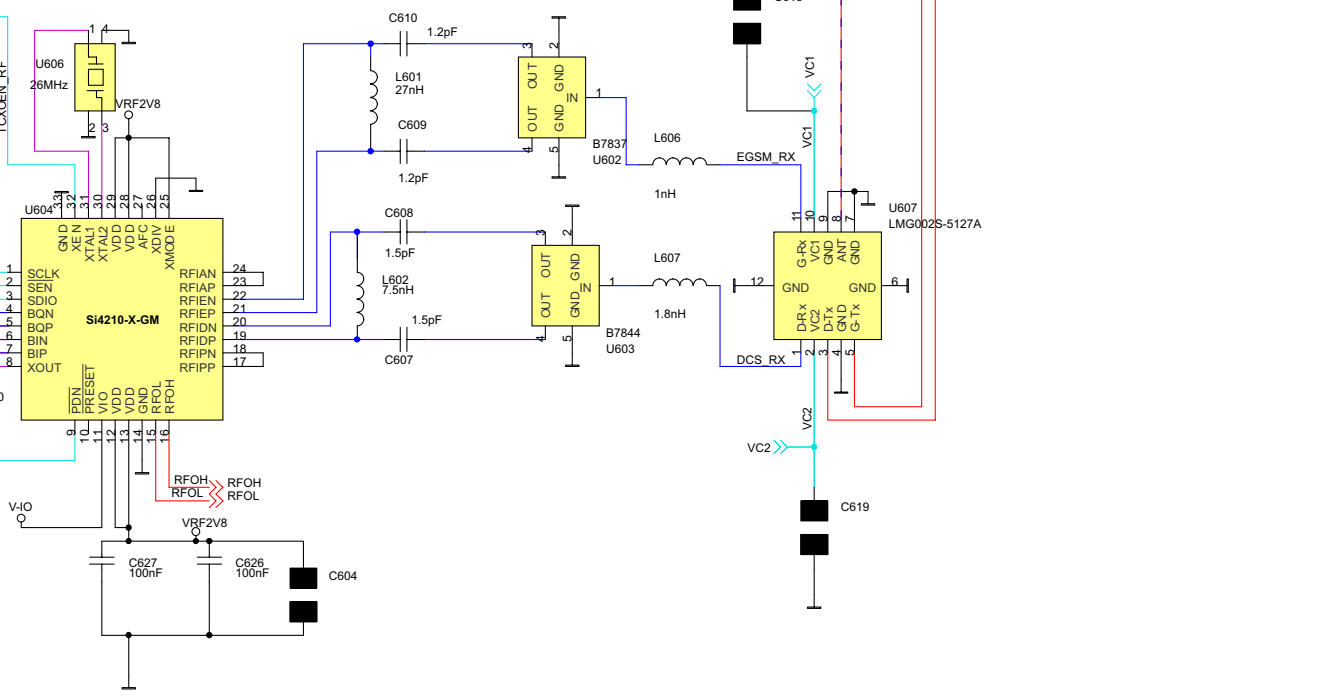
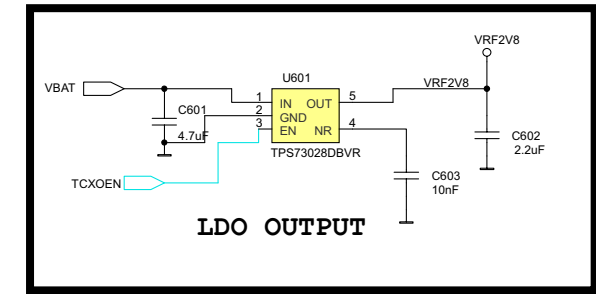
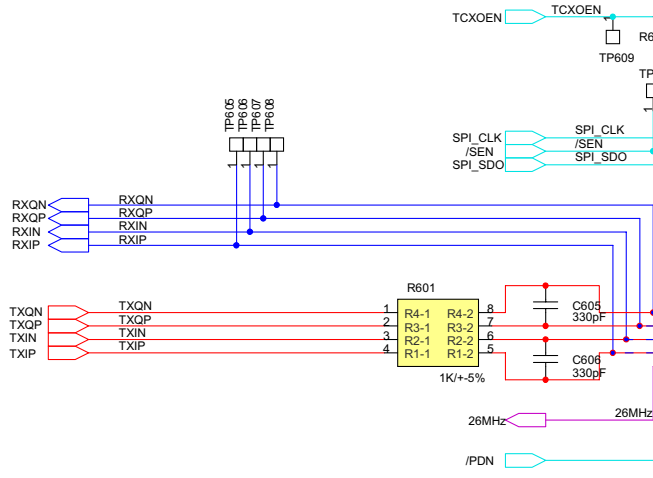
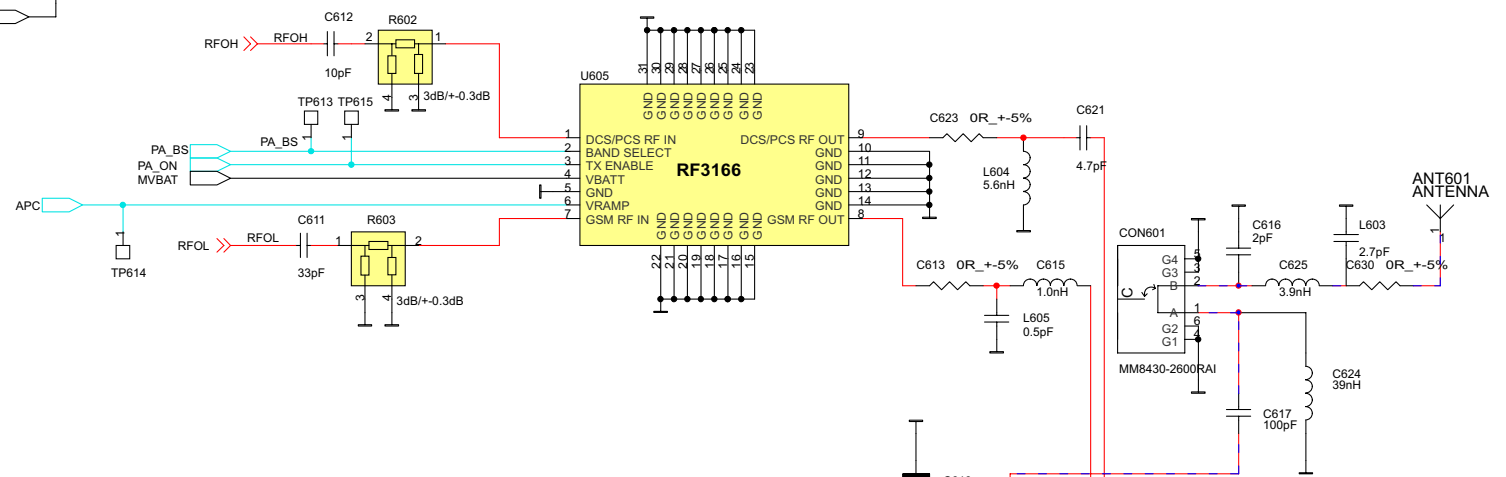
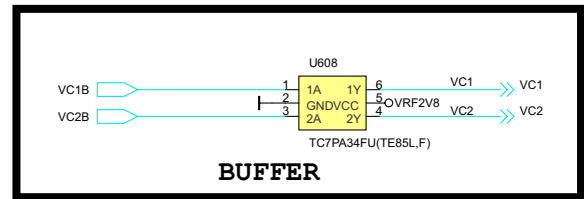
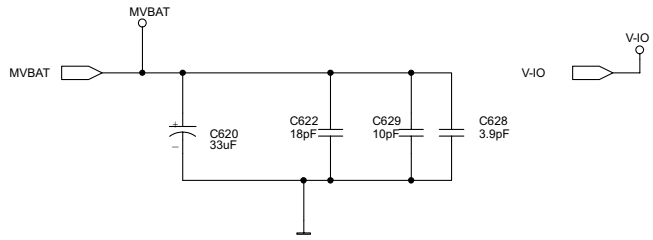

Title	6 RF	
Size	Document Number	Rev
A3		0.2
Date:	星期二, 10, 2005	Sheet 78 of

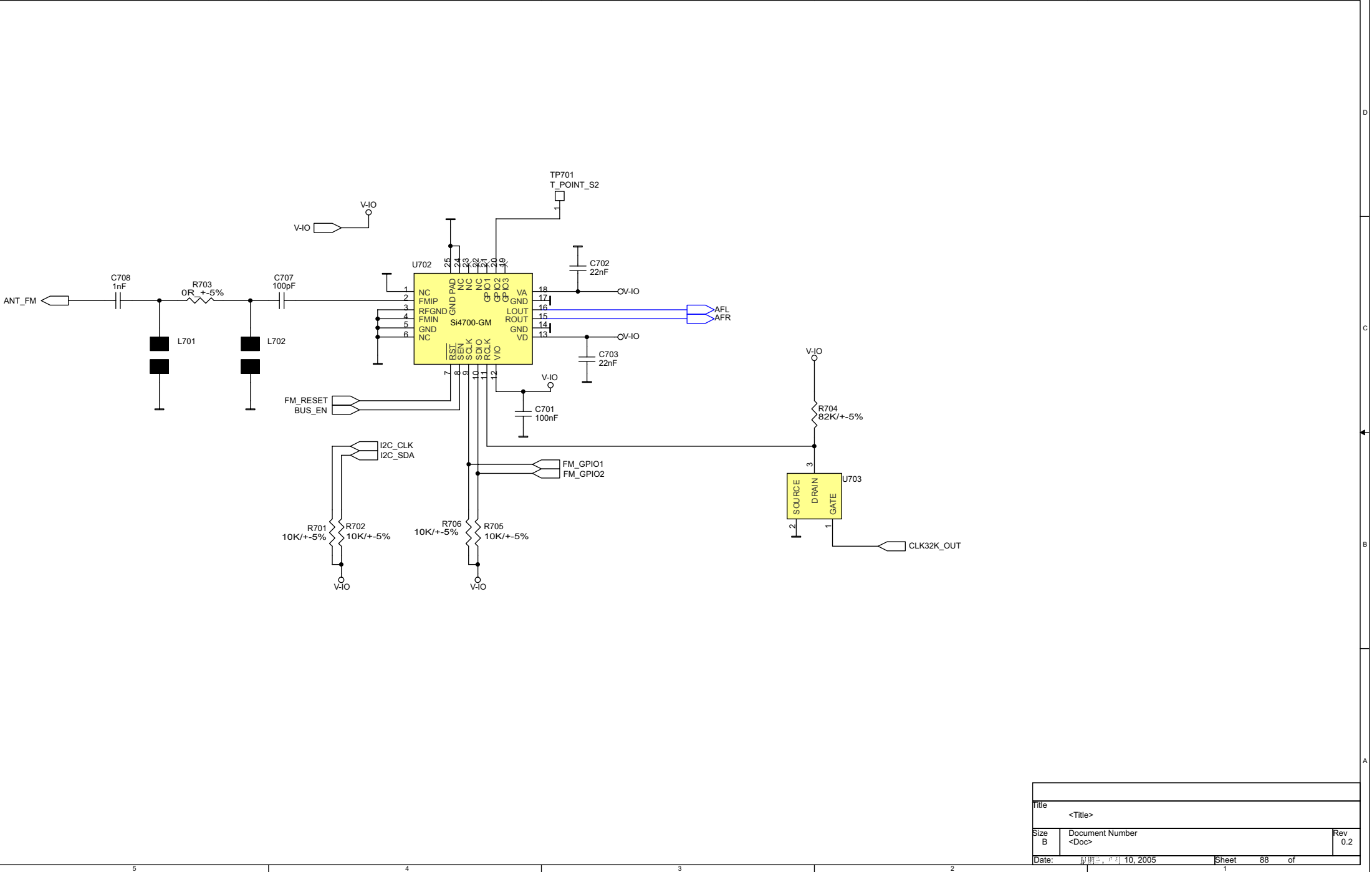

Title		
<Title>		
Size	Document Number	Rev
B	<Doc>	0.2
Date:	日期: 2005.10.10	Sheet 88 of 1



# KEYPAD Board Schematic

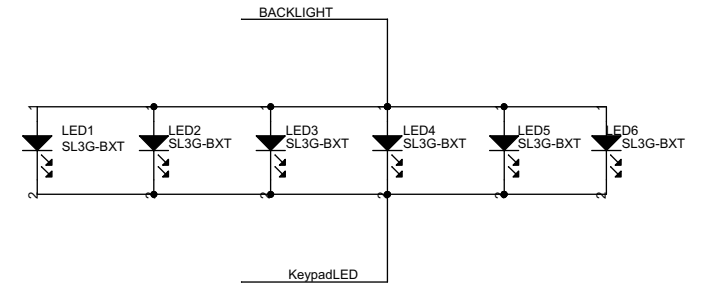
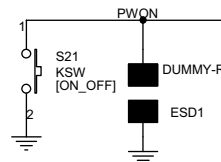
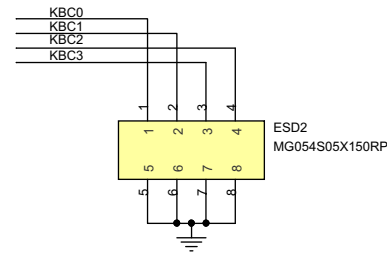
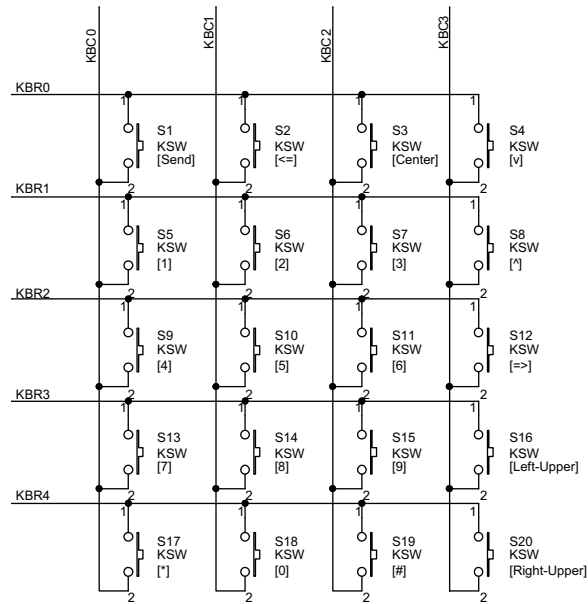
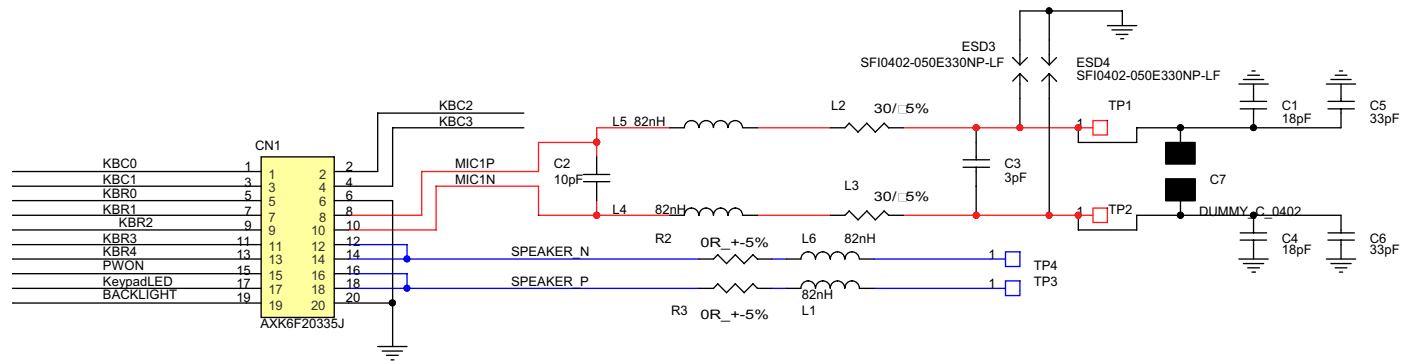

Title		
TCLT Keypad		
Size	Document Number	Rev
B	<Doc>	
Date:	星期二, 2005年11月25, 2005	Sheet 11 of 1