

Service Manual

Level 3

Preliminary

MOTOROLA[™]

DIGITAL WIRELESS TELEPHONE



Model A840 / A860

CDMA 800MHz, 1900MHz & GSM 1800 & 900

Introduction	5
Product Identification	5
Product Names	5
Regulatory Agency Compliance	5
Computer Program Copyrights	6
About this Service Manual	6
Warranty Service Policy	7
Parts Replacement	8
Specifications	9
Product Overview	11
Features	11
General Operation	13
Controls, Indicators, and Input/Output (I/O) Connectors	13
Battery Function	15
Operation	16
Theory of Operation	17
MSM6300 System Overview	17
PM6050 Device Description	19
RFR6000 Overview	22
RFL6000 Overview	23
Tools and Test Equipment	27
Disassembly	28
Removing the Battery Cover	29
Removing and Replacing the RUIM (Removable User Information Memory)	30
Removing and Replacing the Battery	31
Removing and Replacing the Antenna	32
Removing and Replacing the Keypad Bezel	33
Removing and Replacing the Speaker Cover	34
Removing and Replacing the Keyboard Stiffener	35
Removing and Replacing the Flip Assembly and Transceiver Board	36
Removing and Replacing the Flip Display Lens	39
Removing and Replacing the Flip Assembly Sleeve	40
Removing and Replacing the Flip Knuckle	41
Removing the Display Bezel	42
Removing the Display Module	43
Removing and Replacing the Keypad	44
Removing the Motor/Vibrator Assembly	45
Phone Identification	47
Personality Transfer	47
Identification	47
Troubleshooting	48
Programming: Software Upgrade and Flexing	50
Related Publications	50
Exploded View Diagram	51
Exploded View Parts List	52
Accessories	53

Troubleshooting Circuits	54
Block Diagram.....	54
Antenna Schematic.....	55
Antenna Circuit.....	56
Receiver CDMA Schem.....	57
Receiver CDMA Circuit.....	58
GSM Front End Schem.....	59
GSM Front End Circuit.....	60
TX Front End Schem.....	61
GSM TX VCO Schem.....	62
RTR6300 Schematic.....	63
TX GSM & CDMA Circuit.....	64
Accessory Int Schem.....	65
PM Schematic.....	66
PM / Charger Circuit.....	67
MSM Schematic.....	68
Memory Schem.....	69
MSM / Memory Circuit.....	70
RUIM Schem.....	71
MMC Schem.....	72
User Int Schem.....	73
Audio Inter Schem.....	74
Audio Inter Circuit.....	75
Front Board.....	76
Back Board.....	77
Board w/Shields.....	78
 Spare Parts	 79
Spare Parts List.....	79

Introduction

Motorola® Inc. maintains a worldwide organization that is dedicated to provide responsive, full-service customer support. Motorola products are serviced by an international network of company-operated product-care centers as well as authorized independent service firms.

Available on a contract basis, Motorola Inc. offers comprehensive maintenance and installation programs that enable customers to meet requirements for reliable, continuous communications.

To learn more about the wide range of Motorola service programs, contact your local Motorola products representative or the nearest Customer Service Manager.

Product Identification

Motorola products are identified by the model number on the housing. Use the entire model number when inquiring about the product. Numbers are also assigned to chassis and kits. Use these numbers when requesting information or ordering replacement parts.

Product Names

Product names are listed on the front cover. Product names are subject to change without notice. Some product names, as well as some frequency bands, are available only in certain markets.

Regulatory Agency Compliance

This device complies with Part 15 of the FCC Rules. Operation is subject to the following conditions:

- This device may not cause any harmful interference
- This device must accept interference received, including interference that may cause undesired operation

This class B device also complies with all requirements of the Canadian Interference-Causing Equipment Regulations (ICES-003).

Cet appareil numérique de la classe B respecte toutes les exigences du Règlement sur le matériel brouilleur du Canada.

Computer Program Copyrights

The Motorola products described in this manual may include Motorola computer programs stored in semiconductor memories or other media that are copyrighted with all rights reserved worldwide to Motorola. Laws in the United States and other countries preserve for Motorola, Inc. certain exclusive rights to the copyrighted computer programs, including the exclusive right to copy, reproduce, modify, decompile, disassemble, and reverse-engineer the Motorola computer programs in any manner or form without Motorola's prior written consent. Furthermore, the purchase of Motorola products shall not be deemed to grant either directly or by implication, estoppel, or otherwise, any license or rights under the copyrights, patents, or patent applications of Motorola, except for a nonexclusive license to use the Motorola product and the Motorola computer programs with the Motorola product.

About this Service Manual

Using this service manual and the suggestions contained in it assures proper installation, operation, and maintenance. Refer questions about this manual to the nearest Customer Service Manager.

Audience

This service manual aids service personnel in testing and repairing A840 telephones. Service personnel should be familiar with electronic assembly, testing, and troubleshooting methods, and with the operation and use of associated test equipment.

Use of this manual assures proper installation, operation, and maintenance of Motorola products and equipment. It contains all service information required for the equipment described and is current as of the printing date.

Scope

This manual provides basic information relating to A840 telephones, and also to provides procedures and processes for repairing the units at Level 1 and 2 service centers including:

- Unit swap out
- Repairing of mechanical faults
- Basic modular troubleshooting
- Testing and verification of unit functionality
- Initiate warranty claims and send faulty modules to Level 3 or 4 repair centers

Conventions

The following special characters and typefaces are used in this manual to emphasize certain types of information.



Note: Emphasizes additional information pertinent to the subject matter.



Caution: Emphasizes information about actions that may result in equipment damage.



Warning: Emphasizes information about actions that may result in personal injury.



Keys to be pressed are represented graphically. For example, instead of “Press the Menu Key”, you will see “Press ”.

Information from a screen is shown in text as similar as possible to what displays on the screen. For example, `ALERTS` or `ALERTS` or `ALERTS`.

Information that you need to type is printed in **boldface type**.

Warranty Service Policy

The product is sold with the standard 12-month warranty terms and conditions. Accidental damage, misuse, and extended warranties offered by retailers are not supported under warranty. Non warranty repairs are available at agreed fixed repair prices.

Out-of-Box Failure Policy

The standard out of box failure criteria applies. Customer units that fail very early on after the date of sale, are to be returned to Manufacturing for root cause analysis, to guard against epidemic criteria. Manufacturing will bear the costs of early life failure.

Product Support

Customer's original units will be repaired but not refurbished as standard. Appointed Motorola Service Hubs will perform warranty and non-warranty field service for level 2 (assemblies) and level 3 (limited PCB component). The Motorola High Technology Centers will perform level 4 (full component) repairs.

Customer Support

Customer support is available through dedicated Call Centers and in-country help desks. Product Service training is available through the local Motorola Support Center.

Parts Replacement

When ordering replacement parts or equipment, include the Motorola part number and description used in the service manual or supplement.

When the Motorola part number of a component is not known, use the product model number or other related major assembly along with a description of the related major assembly and of the component in question.

In the U.S.A., to contact Motorola, Inc. on your TTY, call: 800-793-7834

Accessories and Aftermarket Division (AAD)

Order replacement parts, test equipment, and manuals from AAD.

U.S.A.

Phone: 800-422-4210

FAX: 800-622-6210

Outside U.S.A.

Phone: 847-538-8023

FAX: 847-576-3023

In EMEA call +49 461 803 1638.

In Asia call +65 648 62995.

Specifications

General Function	Specification
Frequency Range 1900 MHz PCS	1931.250 -1988.750 MHz Rx 1851.250 -1908.750 MHz Tx
Frequency Range 800 MHz CDMA	869.04 - 893.97 Rx 824.04 - 848.97 Tx
Frequency Range GSM 900	880-915 MHz Tx (with EGSM) 925-960 MHz Rx
Frequency Range DCS 1800	1710-1785 MHz Tx 1805-1880 MHz Rx
Channel Spacing	50 kHz PCS 30 kHz CDMA/AMPS
Channels (CDMA)	1200 PCS CDMA 832 CDMA
Channels (GSM)	174 EGSM, 374 PCS, carriers with 8 channels per carrier
Modulation	1M25D1W (1.25 MHz bandwidth) CDMA 3G1XRTT (1.25 MHz bandwidth) CDMA-1X F3 +12 kHz for 100% at 1 kHz AMPS
Transmitter Phase Accuracy	5 Degrees RMS, 20 Degrees peak
Duplex Spacing	80 MHz PCS 45 MHz AMPS
Frequency Stability	± 300 Hz (CDMA) ± 2.5 ppm (AMPS)
Power Supply	3.6V Li Ion 750 mAh battery
Average Transmit Current	310 mA at +13 dBm)
Average Stand-by Current	3.40 mA
Dimensions (with 750 mAh Li ion battery)	94mmX49mmX23mm 3.7 in. x 1.9 in. x 0.9 in.
Size (Volume)	88 cc (5.37 in. ³) without antenna
Weight	≤100g (3.84 oz) with battery
Temperature Range	-30° C to +60° C (-22° F to +140° F)
Humidity	80% Relative Humidity at 50° C (122° F)
Battery Life, 750 mAh Li Ion Battery	Up to 180 minutes digital talk time (IS 95 A/B) Up to 90 minutes talk time (Analog) Up to 250 hours (IS 95 A/B) standby time Up to 350 hours (IS 2000) standby time Up to 15 hours standby time (Analog)
	All talk and standby times are approximate and depend on network configuration, signal strength, and features selected.

Transmitter Function	Specification
RF Power Output	0.20 watts -23 dBm into 50 ohms (CDMA nominal) .6 watts -27.0 dBm into 50 ohms (AMPS nominal)
Input/Output Impedance	50 ohms (nominal)
Transmit Audio Response	6 dBm/octave pre-emphasis
Modulation	1M25DIW (1.25 MHz bandwidth) CDMA
CDMA Transmit Waveform Quality (Rho)	0.94

Receiver Function	Specification
Receive Sensitivity	-116 dBm (AMPS, SINAD, C-MSG weighted) Sinad 12dB or greater -104 dBm (CDMA, 0.5% Static FER) 0.5% or less
Audio Distortion	Less than 5% at 1004 Hz, +/- 8 kHz peak frequency deviation (transmit and receive)
Adjacent and Alternate Channel Desensitization	3% BER max at 107 dBm signal; -94 dBm/30 kHz, -65 dBm/60 kHz
IM (AMPS)	Greater than 65 dB

Product Overview

Motorola A840 mobile telephones feature Code Division Multiple Access (CDMA) technology. The mobile telephone uses a simplified icon and Graphical user interface (GUI) for easier operation, allow Short Message Service (SMS) text messaging, and include clock, alarm, datebook, calculator, and caller profiling personal management tools. The A840 also has a built in camera. The phone provides 32 Embedded ring tones including VibraCall vibrating alert and 32 Downloadable/Customizable iMelody ring tones. The A840 is a dual band quad mode phone that allow user roaming with a single handset between the 800/1900 MHz CDMA bands and the 900/1800 MHz GSM bands.

Manual switching between CDMA and GSM and GSM and CDMA is supported by a soft button and icons to indicate mode of operation.

The A840 telephone consists of a main housing assembly and a flip assembly. The phone has the main circuit board, battery, headset jack, and accessory connector in the main housing assembly. The display and camera are located in the hinged flip assembly.

The flip assembly contains the entire hinge mechanism. It is attached to the main housing by four screws. The main display is on the inside of the flip assembly and a LED display on the outside of the flip assembly. The main display is a 176 x 220 pixels, 262K color TFT LCD. The external display is a 96x64 pixel, 4K-color CSTN. The camera is a 350K pixel, VGA CMOS Sensor Camera.

The main housing assembly includes a battery cover, chassis, main circuit board, keypad and plastic front housing.

The main circuit board contains the Receiver, Transmitter, Synthesizer and Control Logic Circuitry which together comprise the dual band tri-mode phone electronics.

The telephones are made of polycarbonate plastic with a metal enclosure. The display and speaker, as well as the 18-key keypad, transceiver printed-circuit board (PCB), microphone, charger and headphone connectors, and power button are contained within the flip form-factor housing. The 750 mAh Lithium Ion (Li Ion) battery provides up to 178 minutes of talk time in CDMA mode with up to 264 hours of standby time¹.

Features

A840 telephones use advanced, self-contained, sealed, custom integrated circuits to perform the complex functions required for CDMA communication. Aside from the space and weight advantage, microcircuits enhance basic reliability, simplify maintenance, and provide a wide variety of operational functions.

Features available in this family of telephones include:

- 1.3 M-pixel Camera with Integrated Flash
- Multi-Media Messaging (MMS)
- Video clips capture & playback
- Self Portrait Viewfinder External Display
- 64 Polyphonic, 18mm Office Quality Speaker Phone, Stereo Headset Support
- Integrated MP3 Player, MP3 and MIDI Ringers
-

1. All talk and standby times are approximate and depend on network configuration, signal strength, and features selected. Standby times are quoted as a range from DRX=2 to DRX=9. Talk times are quoted as a range from DTX off to DTX on.

-
- Picture Caller ID on External & Internal Display
 - Digital Camera Features: Photo Album, Slide Show Viewer, 4X Digital Zoom, Auto timer, Shutter Tones, Adjustable Resolution, Adjustable Lighting Conditions, Exposure Settings, 4 Image Styles.
 - Digital Camcorder Features: Adjustable video length for up to 3 minutes, Recording sound on/off option, Flash light, Adjustable video quality, Adjustable lighting conditions and exposure settings,
 - SD compatible T-Flash Memory Expansion Slot
 - Connectivity via Bluetooth™ and CE bus
 - Speaker Independent Digit and Name Dialing
 - 5-way Navigation, Simultaneous button press for BREW Gaming
 - PIM functionality, PC Sync with optional Mobile Phone Tools Software, Predictive Text (iTAP), 500 Multi-fielded Phonebook Entries
 - High speed data support (CDMA1X and GPRS).
 - TTY compliant
 - Hearing Aid Telephone Interconnection System (HATIS) support
 - AFLT/aGPS location services²

Simplified Text Entry

iTAP™ predictive text entry. Press a key to generate a character and a dynamic dictionary uses this to build and display a set of word or name options. The iTAP™ feature may not be available in all languages.

2. Network, subscription or service provider dependent feature. Not available in all areas.

General Operation

Controls, Indicators, and Input/Output (I/O) Connectors

The A840 telephones' controls are on the front and side of the device, and on the keyboard as shown in Figure 1. Other hardware features are shown in Figure 2.

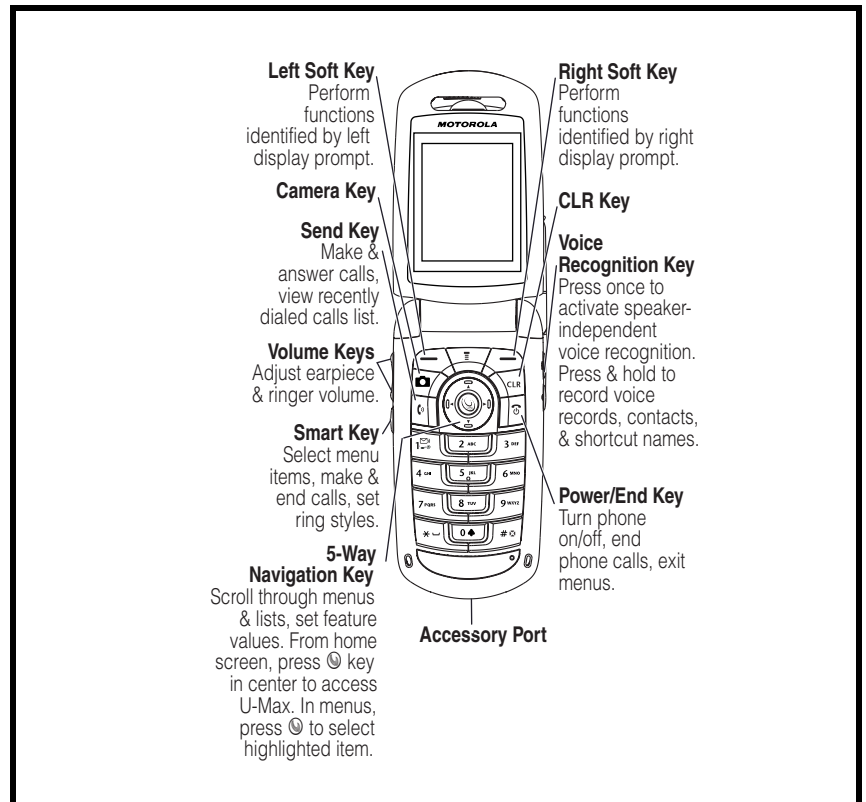

032407o

Figure 1. Controls and Indicators Locations

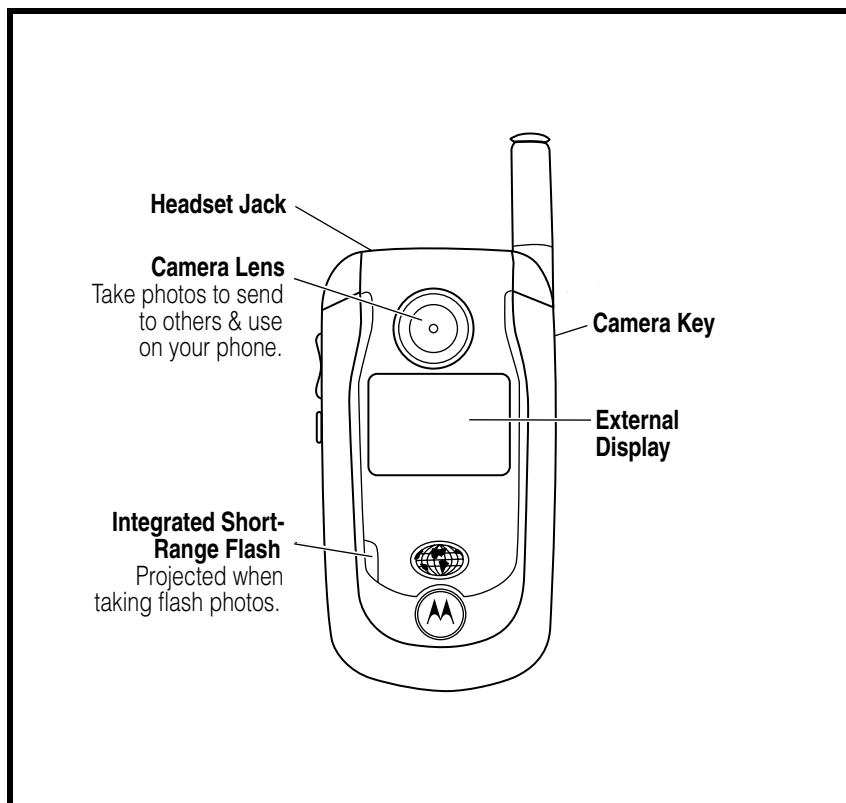

0401830

Figure 2. Hardware Features Locations

Menu Navigation

A840 telephones have a simple icon based GUI. The phone also features a user-definable Quick Access menu accessed by holding down the Menu key. A 5-way navigation key allows you to move easily through menus.

Color Display

The A840 phone features a 176 x 220 pixel, 262K color display. The display provides constant graphical representations of battery capacity and signal strength, as well as the real-time clock.

Display animation makes the phone's icon menu move smoothly as the user scrolls up and down.



Whether a phone displays all indicators depends on the programming and services to which the user subscribes.

Figure 2 shows some common icons displayed on the LCD.

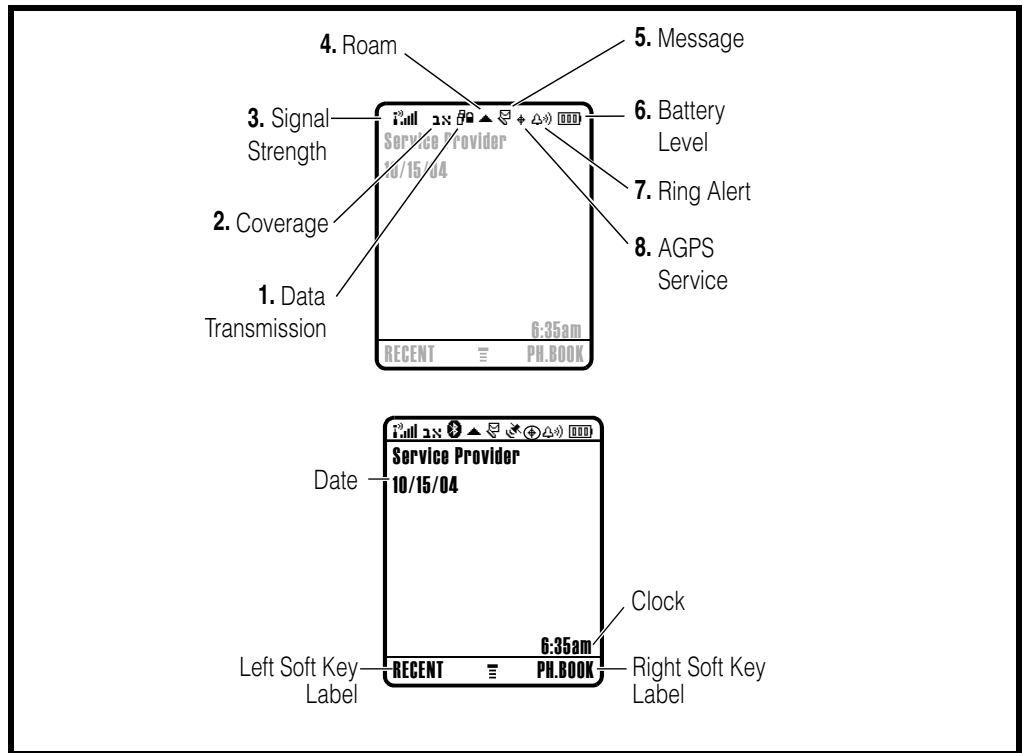

0322370

Figure 3. A840 Display Icon Indicators

Alert Settings

In addition to preset ring tones, A840 telephones allow the user to download additional ring tones. (Availability is carrier and Network dependant).

Motorola A840 phones incorporate the VibraCall[®] discreet vibrating alert that avoids disturbing others when a ringing phone is unacceptable.

Alerts can be set to ring only, vibrate only, vibrate then ring, or no ring or vibrate.

Additionally, the profiling feature allows users to identify incoming calls by a specific ringer tone.

Battery Function

Battery Charge Indicator

The telephone displays a battery charge indicator icon in the idle screen to indicate the battery charge level. The gauge shows four levels: 100%, 66%, 33%, and Low Battery.

Battery Removal

Removing the battery causes the device to shut down immediately and lose any pending work (partially entered phone book entries or outgoing messages, for example).



All batteries can cause property damage and/or bodily injury such as burns if a conductive material such as jewelry, keys, or beaded chains touch exposed terminals. The conductive material may complete an electrical circuit (short circuit) and become quite hot. Exercise care in handling any charged battery, particularly when placing it inside a pocket, purse, or other container with metal objects.



If the battery is removed while receiving a message, the message is lost.



To ensure proper memory retention, turn the phone OFF before removing the battery. Immediately replace the old battery with a fresh battery.

Operation

For detailed operating instructions, refer to the appropriate User Guide listed in the Related Publications section toward the end of this manual.

Theory of Operation

MSM6300 System Overview

QCT's MSM6300 solution, part of QCT's MSM6xxx Mobile Station Modem (MSM™) family of chipsets and system. The 6300-series chipset supports cellular-cdma2000, PCS-cdma2000, gpsone position location, EGSM-900, and DCS-1800 handset operation with direct conversions from RF to baseband using RadioOne Zero-IF architecture. It is optimized to support voice and multimedia data applications while enabling CDMA2000 1X and GSM GPRS network benefits. The MSM6300 solution provides a seamless migration path from 2G to 3G services and applications, and increases voice capacity for CDMA2000 1X networks. It will also enable CDMA developers to quickly develop 3G CDMA2000 1X handsets that exceed the specifications of mobile stations for worldwide cdmaOne™ and 3G 1xMC systems, including those based on IS-95A/B, IS-2000 and 3GPP 51.010 standards.

The MSM6300 chipset solution consists of the MSM6300 Baseband processor, direct conversion RFL6000™ and RFR6000™ receive devices, RTR6300™ RF transceiver IC, PM6050™ power management device and a compatible power amplifier device. These devices perform all of the signal processing and power management in the subscriber unit.

The MSM6300 chipset and system software features radioOne direct conversion architecture and incorporates a low-power, high-performance RISC microprocessor core featuring the ARM926EJ-S™ CPU and Jazelle™ accelerator circuit for advanced Java applications from ARM® Limited. The MSM6300 solution integrates two, low-power, high-performance QDSP4000™ digital signal processor (DSP) cores. Use of the ARM926EJ-S™ CPU and QDSP4000 DSP eliminates the need for the multimedia companion processor(s) normally required for video-based applications, playing MP3 music files and MIDI synthesizer/CMX functions.

The MSM6300 chipset and system software incorporates the advanced feature set of QCT's Wireless Internet Launchpad™ suite of technologies, integrated MPEG-4 video decoding/encoding, MP3 audio decoding, a 2D/3D graphics accelerator for advanced gaming applications, a Compact Media Extension (CMX™)/MIDI synthesizer, a digital camera interface, an enhanced LCD interface, and JPEG encoding/decoding.

The MSM6300 solution supports QUALCOMM's gpsOne™ position location technology, including standalone mode in which the handset can act as a GPS receiver. The gpsOne solution, featuring SnapTrack™ technology, offers robust data availability under the most challenging conditions, whether in concrete-and-steel high-rises, convention centers, shopping malls, or urban canyons. Using a hybrid approach that utilizes signals from both the GPS satellite constellation and from CDMA cell sites, the gpsOne solution enhances location services availability, accelerates the location determination process and provides better accuracy for callers, whether during emergency situations or while using GPS-enabled commercial applications. The MSM6300 solution also supports the Wireless Internet Launchpad's VectorOne™ compass capability.

The MSM6300 chipset reduces radio bill-of-materials (BOM) by the introduction of RadioOne RF devices System BOM is further reduced by supporting interfaces to next generation memories architectures such as; NAND FLASH, Pseudo SRAM (PSRAM), Page and Burst mode NOR FLASH and low power SDRAM (LP-SDRAM).

QCT provides a complete software suite, Dual-Mode Subscriber (DMSS) software, for building handsets around the MSM6300 chipset. DMSS software is designed

to run on a Subscriber Unit Reference (SURF) phone platform, an optional development platform optimized to assist in evaluating, testing and debugging DMSS software.

The MSM6300 device is offered in a 341-ball, 0.5mm pitch Chip Scale Package (CSP) production package. Additionally, the MSM6300 solution supports QUALCOMM's Binary Run-time Environment for Wireless™ (BREW™) applications development platform.

The MSM6300 device interfaces directly with QCT's new radioOne RF ASICs. radioOne is a revolutionary technology for CDMA transceivers that uses Zero Intermediate Frequency (ZIF), or direct conversion, architecture for the wireless handset market. This direct conversion eliminates the need for large IF Surface Acoustic Wave (SAW) filters and additional IF circuitry, which significantly reduces the handset BOM parts count, facilitating multiband and multimode handsets that can be produced in smaller form factors. radioOne technology also incorporates the frequency synthesis and passive elements used in converting Baseband signals to and from RF. A single external dualband local oscillator is used for the CDMA and GSM receiver, which will provide the capabilities needed to operate on systems around the world and will simplify the procurement of parts and the cost of designing CDMA/GSM handsets.

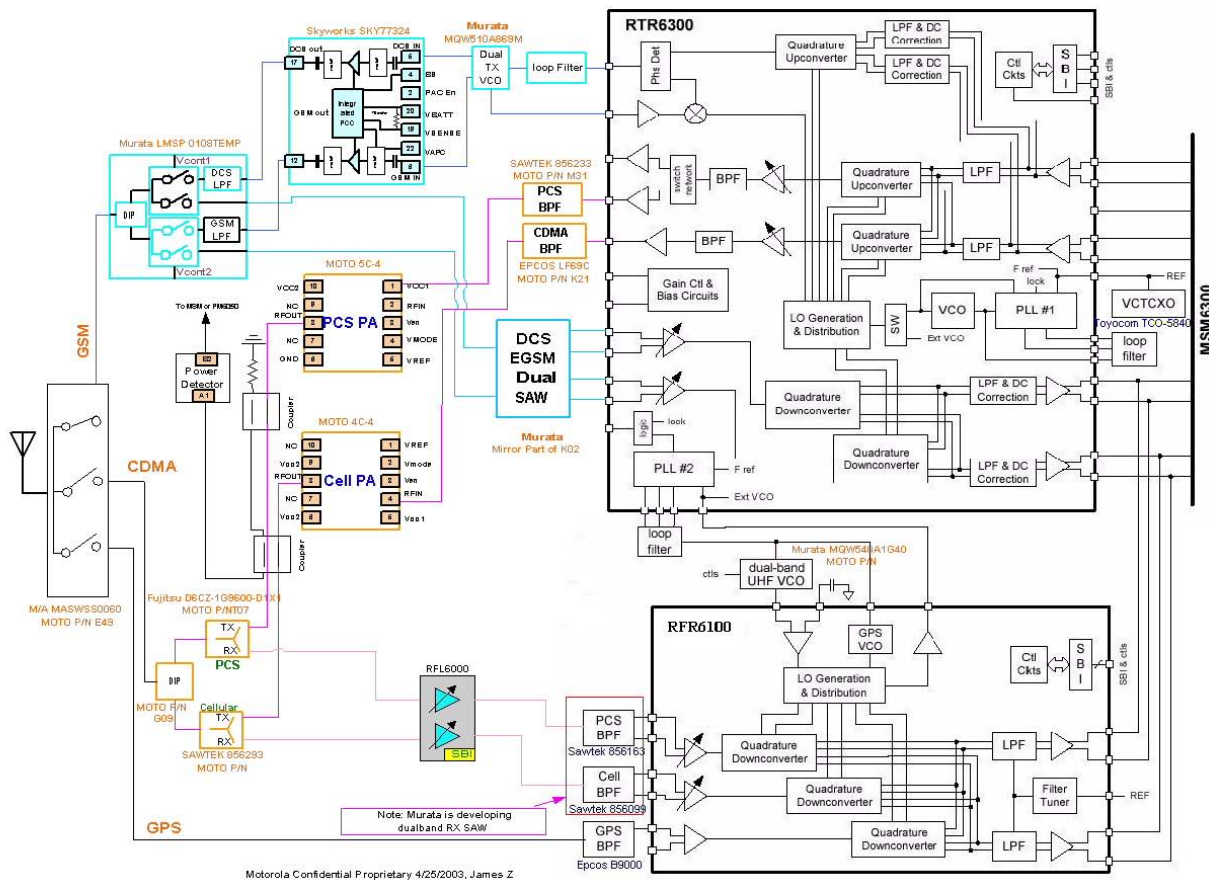

Figure 4. Motorola MSM6300 System Block Diagram

PM6050 Device Description

The PM6050 device (Figure 2) integrates all wireless handset power management, general housekeeping, and user interface support functions into a single mixed signal IC. Its versatile design is suitable for CDMA and non-CDMA handsets, as well as other wireless products such as PC cards, modems, PDAs, etc. The power management portion accepts power from all the most common sources – battery, external charger, adapter, coin cell back-up – and generates all the regulated voltages needed to power the appropriate handset electronics. It monitors and controls the power sources, detecting which sources are applied, verifying that they are within acceptable operational limits, and coordinates battery and coin cell recharging while maintaining the handset electronics supply voltages. Eight programmable output voltages are generated using low dropout voltage regulators, all derived from a common trimmed voltage reference.

The device's general housekeeping functions include a 10-bit ADC whose input is selected by a 10-position analog multiplexer having five internal and five external connections. The internal connections are used to monitor voltage sources, charging status, and current flow. The five external connections are available to monitor system parameters such as temperature, RF output power, and battery ID. Various oscillator, clock, and counter circuits are provided to initialize and maintain valid pulse waveforms and measure time intervals for higher-level handset functions. A dedicated controller manages the TCXO warm-up and signal buffering, and key parameters (under-voltage lockout and crystal oscillator signal presence) are monitored to protect against detrimental conditions. Handset-level user interfaces are also supported. The IC includes four backlight or LED drivers with brightness (current) control that could be used for the keypad, the LCD, and two user definable handset users of incoming calls; these independent vibrator and ringer/buzzer drivers alert handset users of incoming calls; these independent drivers can be used simultaneously for dual-function applications. A speaker driver with volume control supports speakerphone and melody-ringer applications. The speaker and ringer/buzzer drivers share common PM6050 circuitry, so only one can be used at a time.

An MSM device controls and statuses the PM6050 IC using a three-line Serial Bus Interface (SBI) supplemented by an Interrupt Manager for time-critical information. Another dedicated IC interface circuit monitors multiple trigger events and controls the power-on sequence. The PM6050 is a mixed signal BiCMOS device and is available in the 56-pad Bump Chip Carrier (56 BCCP) package that includes a large center slug for electrical ground and thermal relief. Since the PM6050 IC includes so many diverse functions, its operation is more easily understood by considering major functional blocks individually. Therefore, the PM6050 document set is organized according to the following device functionality:

- Input Power Management
- Output Voltage Regulation
- General Housekeeping
- User Interfaces
- IC Interfaces

Most of the information contained in this Device Specification is organized accordingly – including the circuit groupings within the block diagram (Figure 1-1) and detailed electrical specifications (Section 4). To begin, introductory descriptions of all the PM6050 device's circuits are provided in the following subsections.

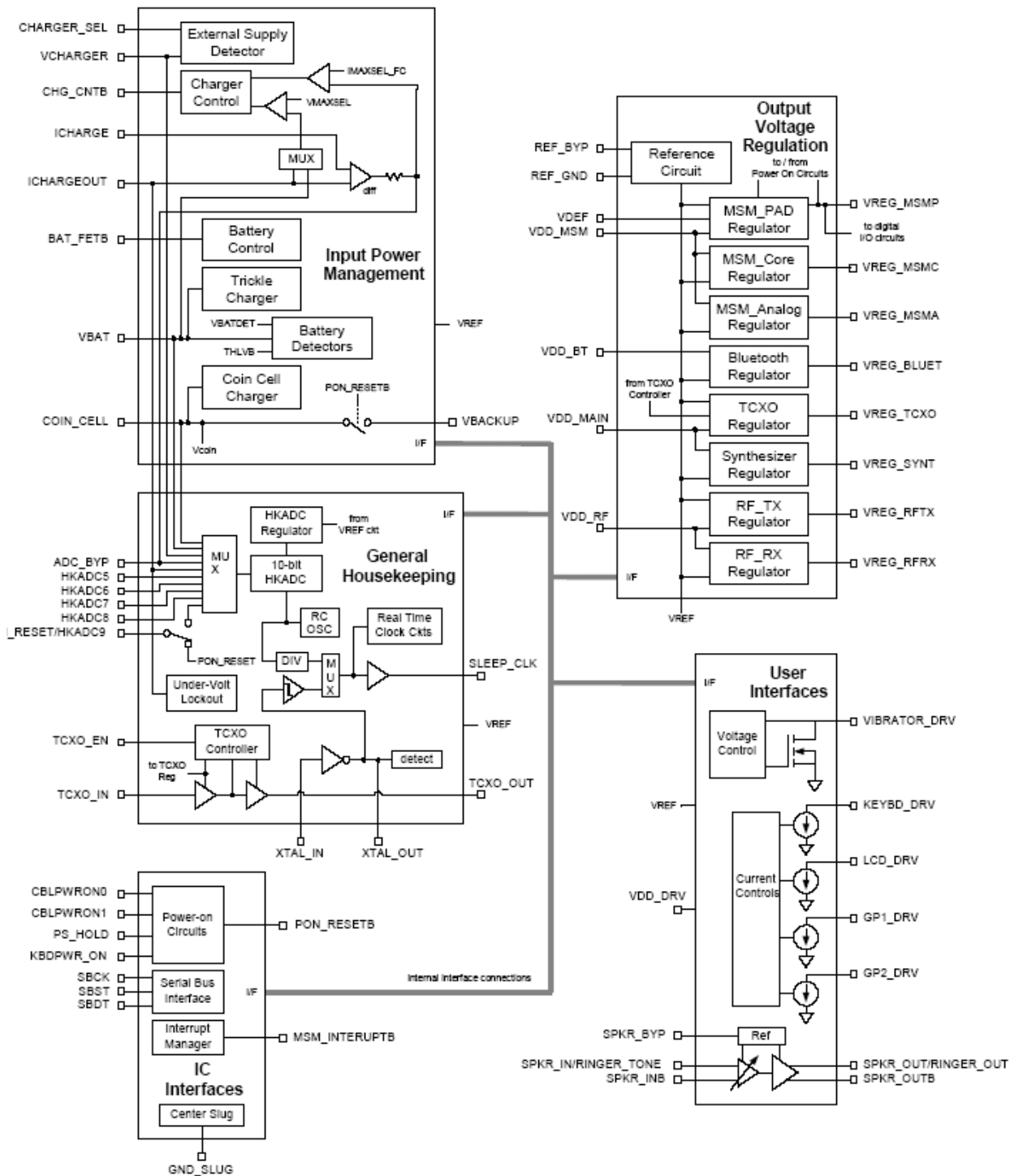

Figure 5. PM6050 Block Diagram

RTR00 Overview

The RTR6300 is a RF transceiver IC, an integral component of QUALCOMM's 6300-series chipset. All 6300-series ICs are highly integrated and fulfill specific functions; functional requirements are partitioned between the ICs to yield complete, optimal multi-band, multi-mode transceiver implementations. Overall transceiver performance depends on the combined, complementary performance of all the ICs in the chipset. The RTR6300 IC supports multi-band, multi-mode phones with two receiver signal paths and four transmitter signal paths.

Receiver paths:

- EGSM-900
- DCS-1800

GSM Transmitter paths:

- EGSM-900 (using OPLL techniques)
- DCS-1800 (using OPLL techniques)

CDMA Transmitter paths (cdma2000, also known as 1x cdma, cdma 1x, or simply 1x):

- Cellular bands
- PCS bands

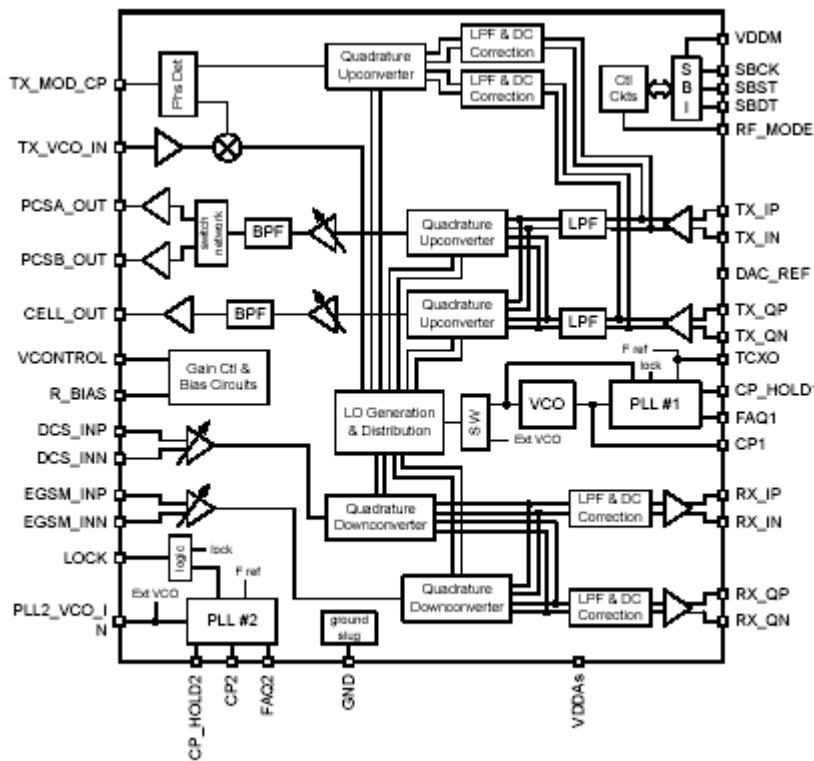

Figure 6. RTR6300 Functional Block Diagram

Numerous secondary functions are integrated on-chip as well:

Phase-locked loop circuits:

- PLL#1 and an on-chip VCO supports cdma2000 TX modes
- PLL#2

Supports EGSM RX & TX, DCS RX &TX, and CDMA2000 RX modes using an external VCO

Supports gpsone using the RFR6000 on-chip VCO

Transceiver LO generation and distribution circuits

- EGSM-900 RX and TX
- DCS-1800 TX and RX
- Cellular-TX
- PCS- TX

Analog support functions

- Reference signal of the MSM transmit DACs
- Transmit gain control
- Bias control
- Digital Interfaces
- 3 –line serial bus interface (SBI)
- Dedicated RF_ON (TX_ON) control line

The device is fabricated using an advanced SiGe BiCMOS process that accommodates high-frequency, high-precision analog circuits as well as low-power CMOS functions. Designed to operate with 2.7 to 3.0 Volt power supplies, it is compatible with single-cell Li-Ion batteries.

RTR6300 is available in a small, thermally efficient package (48 BCCP)

RFR6000 Overview

The RFR6000 is an RF-to-Baseband receiver IC, an integral component of QUALCOMM's radioOne™ Zero-IF chipset. All radioOne ICs are highly integrated and fulfill specific functions; functional requirements are partitioned between the ICs to yield complete, optimal transceiver implementations. Overall radioOne performance depends on the combined, complementary performance of all the ICs in the chipset.

The RFR6000 IC provides the zero-IF receiver signal path, from RF to analog Baseband, for multi-band, multi-mode handsets including combinations of the following:

Bands:

- Cellular bands
- PCS bands
- GPS band

Modes:

- AMPS-FM
- CDMA (known as IS-95, cdmaOne, IS-98, cdma2000, 1x EV-DO)
- gpsOne™

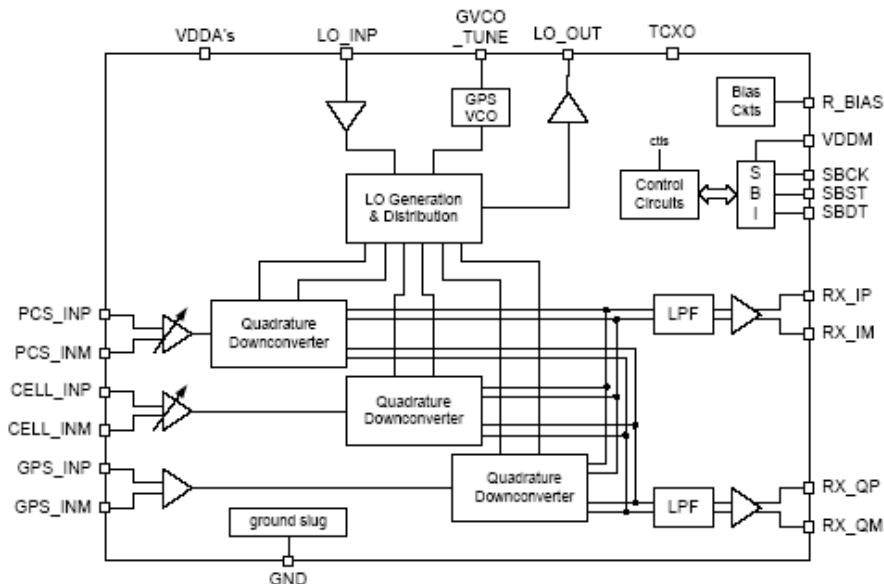

Figure 7. RFR6000 Block Diagram

Numerous secondary functions are integrated on-chip as well: the Rx LO generation and distribution circuits; the GPS VCO circuit; and various interface, control, and status circuits. The RFR6000 Zero-IF architecture and highly integrated implementation greatly reduces handset PCB size and material costs compared to earlier-generation RFICs. Major RFR6000 functional blocks are described in this chapter's subsections.

The RFR6000 IC accepts as many as three inputs from the handset RF front-end design (PCS, Cellular, and GPS). The analog Baseband outputs interface with one of QUALCOMM's Mobile Station Modem (MSM6XXX) devices that also provide status and control signaling. Power reduction features controlled by the MSM (such as selective circuit power-down, gain control, and bias control) extend handset standby time. Integrated Rx LO circuits, ideally supplemented by the RFT6100 transmitter IC, provide frequency plan flexibility and further reduce PCB parts count.

The device is fabricated using an advanced SiGe BiCMOS process that accommodates high-frequency, high-precision analog circuits as well as low-power CMOS functions and is designed to operate with 2.7 to 3.0 volt power supplies. Although the MSM operates at lower voltages, compatibility is assured and latch-up is prevented by RFR6000 input and output buffers when its VDDM (pin 23) is connected to the MSM pad voltage.

The RFR6000 IC is available in the 40-pin bump chip carrier (40 BCCP) package that includes a large center ground slug for improved RF grounding, mechanical strength, and thermal continuity.

RFL6000 Overview

The RFL6000 is a dual LNA IC, an integral component of QUALCOMM's radioOne Zero-IF chipset. All radioOne ICs are highly integrated and fulfill specific functions; functional requirements are partitioned between the ICs to yield complete, optimal transceiver implementations. Overall radioOne performance depends on the combined, complementary performance of all the ICs in the chipset

The RFL6000 IC includes two LNA circuits, one optimized for the Cellular band and one for PCS. The LNAs are separated from all other receive functions contained within the RFR6000 receiver IC to improve mixer LO to RF isolation – a critical parameter in the Zero-IF architecture. Isolation is further improved using high reverse isolation circuits in the LNA designs.

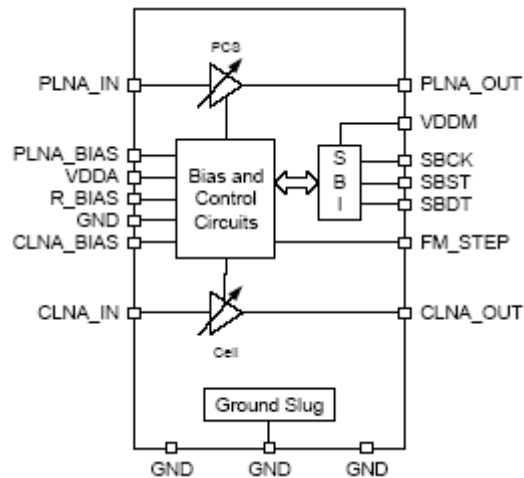

Figure 8. RFL6000 Block Diagram

The RFL6000 is a multi-band multi-mode IC:

Bands:

- Cellular bands
- PCS bands

Modes:

- AMPS-FM
- CDMA (known as IS-95, cdmaOne, IS-98, cdma2000, 1xEVDO)

The two LNAs are dedicated to different frequency bands; the CLNA supports Cellular bands while the PLNA supports PCS bands. The PLNA gain is always controlled via the Serial Bus Interface (SBI) with three valid settings: Max, Mid, and Low. Three CLNA gain states are also controlled via the SBI for CDMA signal reception, but only two gain states are available for FM operation (Max and Low). When operating in the Cellular-FM mode, the CLNA gain is controlled by a dedicated MSM signal applied to pin 6 (FM_STEP) rather than the SBI.

The IC operating mode and LNA bias currents are automatically adjusted via software to minimize DC power consumption. The IC is placed in Sleep, Rx, and Rx/Tx modes depending upon the handset's status, with LNA bias current also adjusted to meet RF performance requirements with minimal power dissipation when active.

The device is fabricated using a SiGe BiCMOS process ideally suited for high-performance RF circuits and digital I/O functions. All analog/RF functions operate off a common supply voltage (VDDA), with the digital I/O circuits operating off a separate supply (VDDM). VDDM is connected to the MSM_PAD voltage to assure compatibility across the digital interface and prevent latch-up conditions.

The RFL6000 IC is packaged in a very small 16-pin bump chip carrier (16 BCCP) that includes a center slug for soldering directly to PCB ground. This provides excellent RF grounding, mechanical strength, and a solid thermal path.

Tools and Test Equipment

The following table lists tools and test equipment recommended for disassembly and reassembly of A840 telephones. Use either the listed items or equivalents.

Table 1. General Test Equipment and Tools

Motorola Part Number ¹	Description	Application
RSX4043-A	Torque Driver	Used to remove and replace screws
—	Torque Driver Bit T-6 Plus, Apex 440-6IP Torx Plus or equivalent	Used with torque driver
See Table 7	Rapid Charger	Used to charge battery and power phone
0180386A82	Antistatic Mat Kit (includes 66-80387A95 antistatic mat, 66-80334B36 ground cord, and 42-80385A59 wrist band)	Provides protection from damage to device caused by electrostatic discharge (ESD)
6680388B67	Disassembly tool, plastic with flat and pointed ends (manual opening tool)	Used during assembly/disassembly of phone
6680388B01	Tweezers, plastic	Used during assembly/disassembly
—	Digital Multimeter, HP34401A ²	Used to measure battery voltage
6688054N01	Flip disassembly tool	Used to disassembly the flip assembly

1. To order in North America, contact Motorola Aftermarket and Accessories Division (AAD) at (800) 422-4210 or FAX (800) 622-6210; Internationally, AAD can be reached by calling (847) 538-8023 or by fax (847) 576-3023.

2. Not available from Motorola. To order, contact Hewlett Packard at (800) 452-4844.

Disassembly

The procedures in this section provide instructions for the disassembly of a A840 telephone. Tools and equipment used for the phone are listed in Table 1, preceding.



Many of the integrated devices used in this phone are vulnerable to damage from electrostatic discharge (ESD). Ensure adequate static protection is in place when handling, shipping, and servicing the internal components of this equipment.



Avoid stressing the plastic in any way to avoid damage to either the plastic or internal components.

Removing the Battery Cover

1. Ensure the phone is turned off.
2. Slide the battery cover latch as shown in Figure 9.
3. Gently lift the top end of the battery cover away from the phone.
4. Lift the battery cover away from the phone.

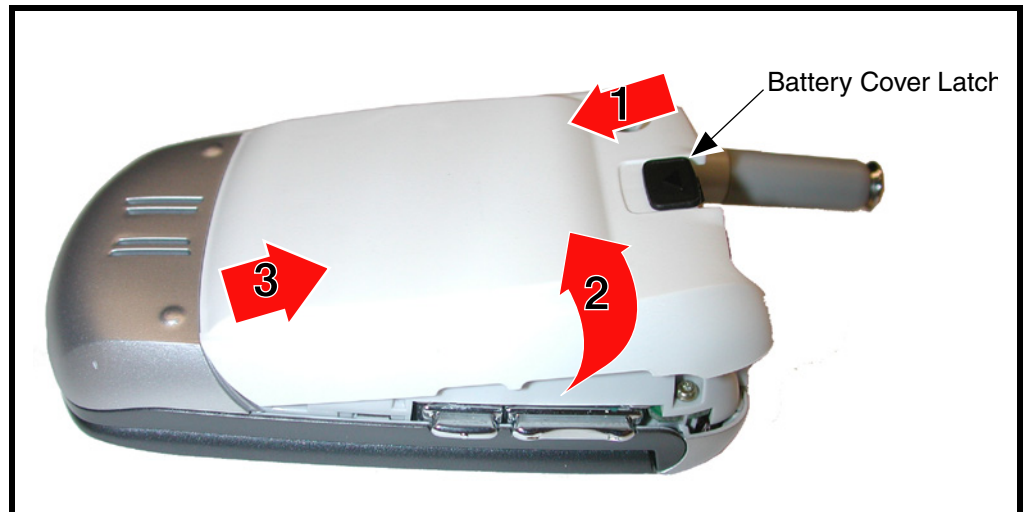

0403350

Figure 9. Removing the Battery Cover

5. To replace, align the battery cover to the phone.
6. Slide the bottom end of the battery cover into the phone.
7. Lower the top end of the battery cover onto the phone until battery cover latch snaps into place.

Removing and Replacing the RUIM (Removable User Information Memory)

1. Remove the battery cover as described in the procedures.
2. Turn the battery cover over and unlock the RUIM latch as shown in Figure 9.
3. Lift the RUIM out of the battery door.

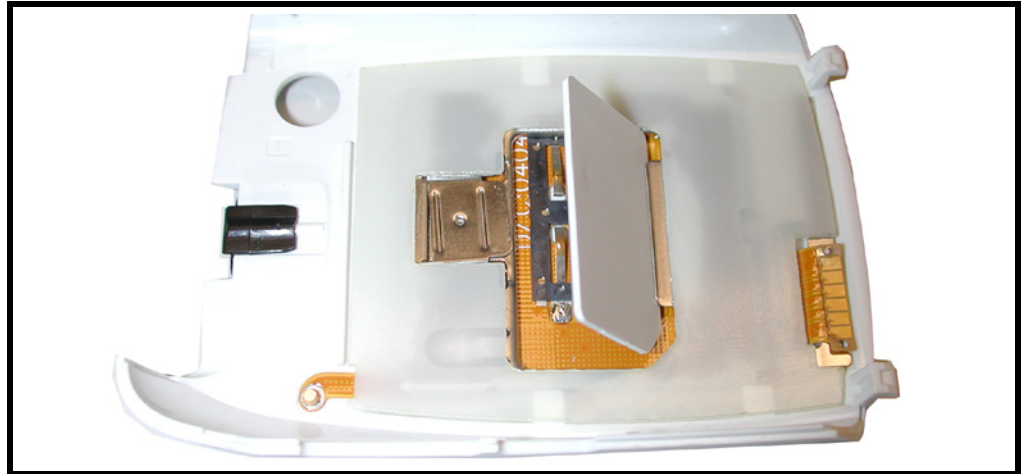

0403360

Figure 10. Removing the RUIM

4. To replace, place the RUIM into position in the battery door. Observe the notched corner when inserting the RUIM.
5. Slide the RUIM latch over the RUIM to secure it.
6. Turn the battery cover over.
7. Replace the battery cover as described in the procedures.

Removing and Replacing the Battery



All batteries can cause property damage and / or bodily injury such as burns if a conductive material such as jewelry, keys, or beaded chains touch exposed terminals. The conductive material may complete an electrical circuit (short circuit) and become quite hot. Exercise care in handling any charged battery, particularly when placing it inside a pocket, purse, or other container with metal objects.

1. Ensure the phone is turned off.
2. Remove the battery cover as described in the procedures.
3. Lift the top of the battery near the antenna out of the battery compartment as shown in Figure 11.
4. Lift the battery out of the phone.

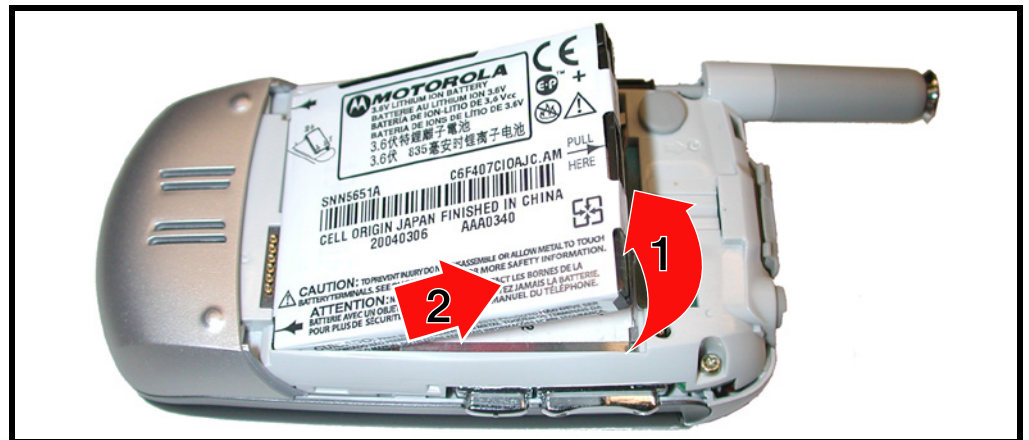

0403360

Figure 11. Removing the Battery

5. To replace, align the battery with the battery compartment so the contacts on the battery match the battery contacts in the phone.
6. Insert the battery, printed arrow first, into the battery compartment and push down.
7. Insert the ridge at the bottom of the housing into the base of the phone, then push the battery down and snap it into place.

Removing and Replacing the Antenna

1. Remove the battery cover, and battery as described in the procedures.
2. By hand, rotate the antenna base counterclockwise, as indicated by the red arrows until loose.
3. When the antenna threads are completely disengaged, slide the antenna out of the housing. See Figure 12.

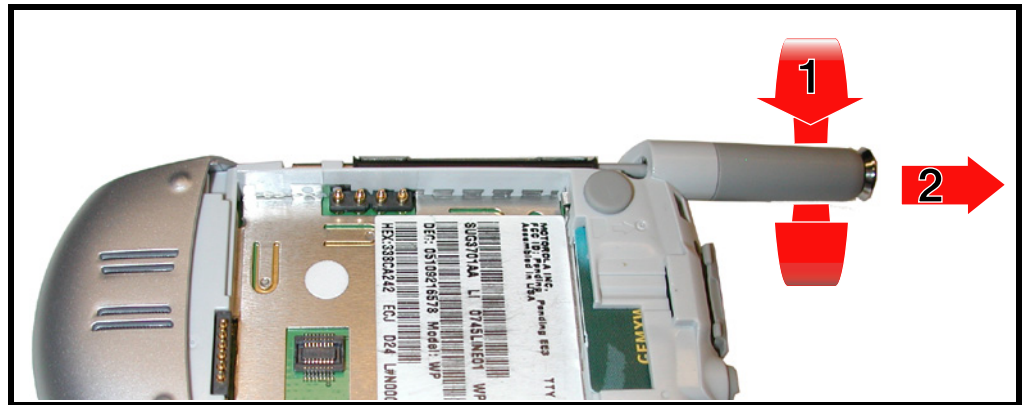

03222130

Figure 12. Removing the Antenna



Ensure antenna threads are properly engaged before tightening to prevent damage to the antenna or housing.

4. To replace, insert the threaded end of the antenna carefully into the housing and, after ensuring the threads are properly engaged, rotate clockwise. Tighten firmly by hand.
5. Replace the battery, and battery cover as described in the procedures.

Removing and Replacing the Keypad Bezel

1. Remove the battery cover, battery, and antenna, as described in the procedures.
2. Turn the phone over and carefully insert the disassembly tool under the keypad bezel and gently bend the bezel outward from the rear housing to release the 2 snaps on the side of the housing (See Figure 13).

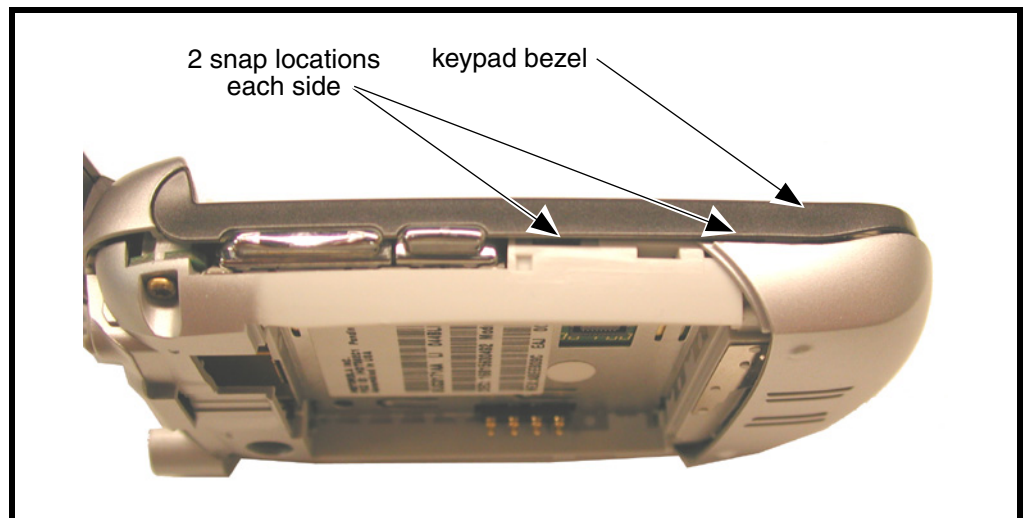

0403460

Figure 13. Removing the Keypad Bezel

3. Repeat step 2 for the other side of phone.
4. When all four snaps have been released, carefully lift the keypad bezel away from the phone.
5. To replace, align the keypad bezel with the phone housing.
6. Carefully press the keypad bezel into the phone housing until the snaps engage.
7. Replace the antenna, battery, and battery cover as described in the procedures.

Removing and Replacing the Speaker Cover

1. Remove the battery cover, battery, antenna, and keypad bezel as described in the procedures.
2. Insert the disassembly tool under the outer edges of the speaker cover to release the latches on each side.
3. Slide the speaker cover toward the antenna to remove.

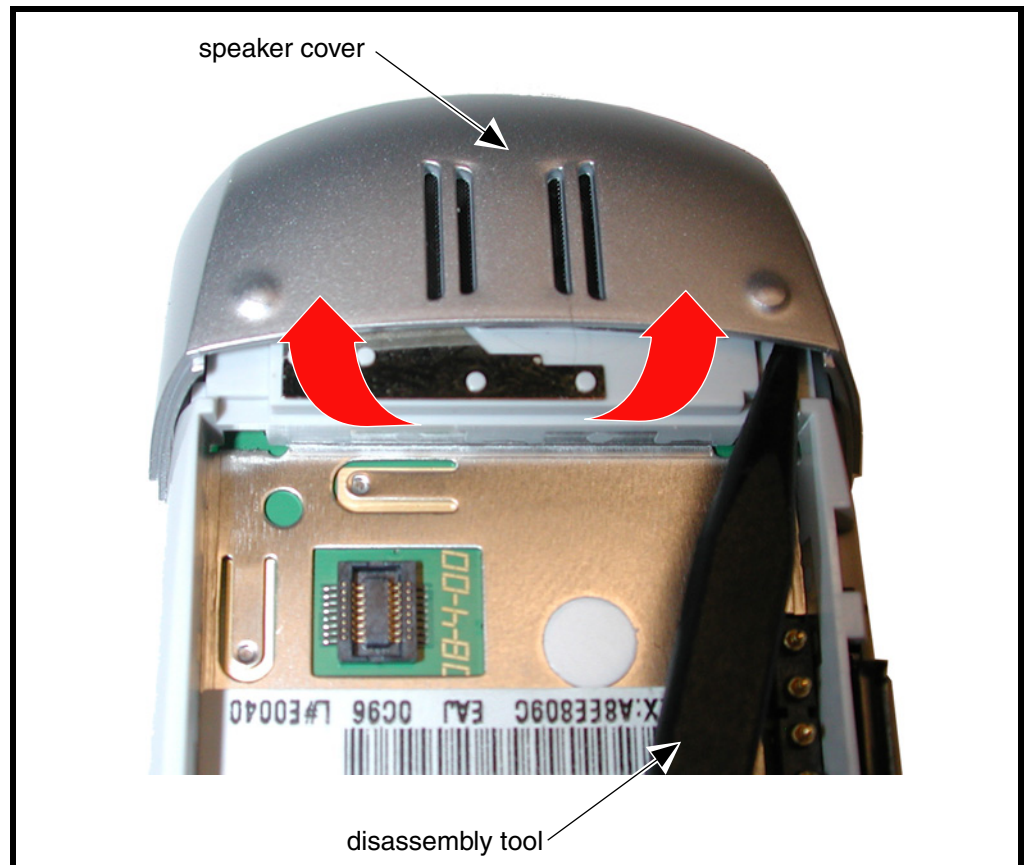

040347o

Figure 14. Removing the Speaker Cover

4. To replace, slide the speaker cover onto the phone.
5. Gently press down on the sides of the speaker cover to engage the latches.
6. Replace the keypad bezel, antenna, battery, and battery cover as described in the procedures.

Removing and Replacing the Keyboard Stiffener

1. Remove the battery cover, battery, antenna, keypad bezel, and speaker cover as described in the procedures.
2. Remove the two screws at the bottom of the phone near the polyphonic speaker (See Figure 15)..

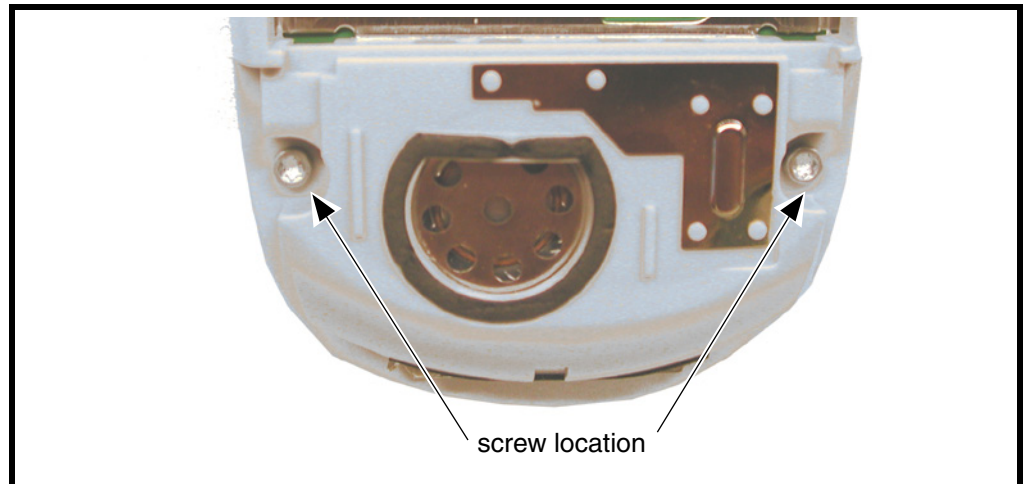

0322160

Figure 15. Removing the rear housing bottom screws

3. Lift the bottom end of the keyboard stiffener toward the flip knuckles.
4. Use the disassembly tool to disconnect the keypad flex connector (See Figure 16).

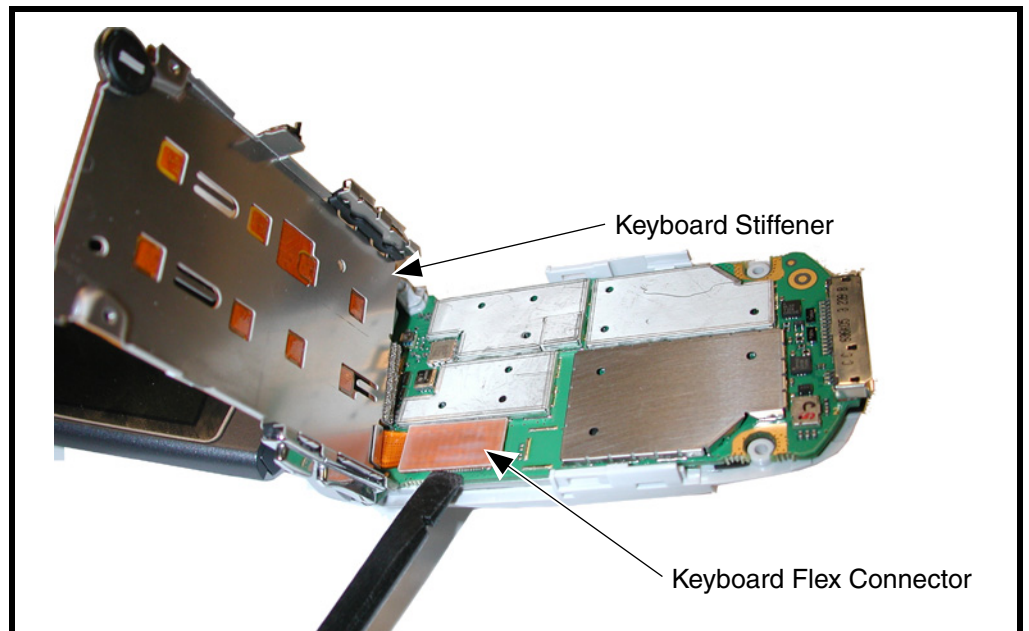

0322160

Figure 16. Removing the Keyboard Flex Connector

5. Lift the keyboard stiffener away from the phone.
6. To replace, align the keyboard stiffener to the transceiver board.
7. Connect the keyboard flex connector to its socket on the transceiver board.
8. Lower the keyboard stiffener onto the transceiver board.
9. Insert and tighten two screws near the polyphonic speaker assembly.
10. Replace the speaker cover, keypad bezel, antenna, battery, and battery cover as described in the procedures.

Removing and Replacing the Flip Assembly and Transceiver Board

1. Remove the battery cover, battery, antenna, keypad bezel, speaker cover, and keyboard stiffener as described in the procedures.
2. Use the disassembly tool to disconnect the flip assembly flex connector. (See Figure 17).

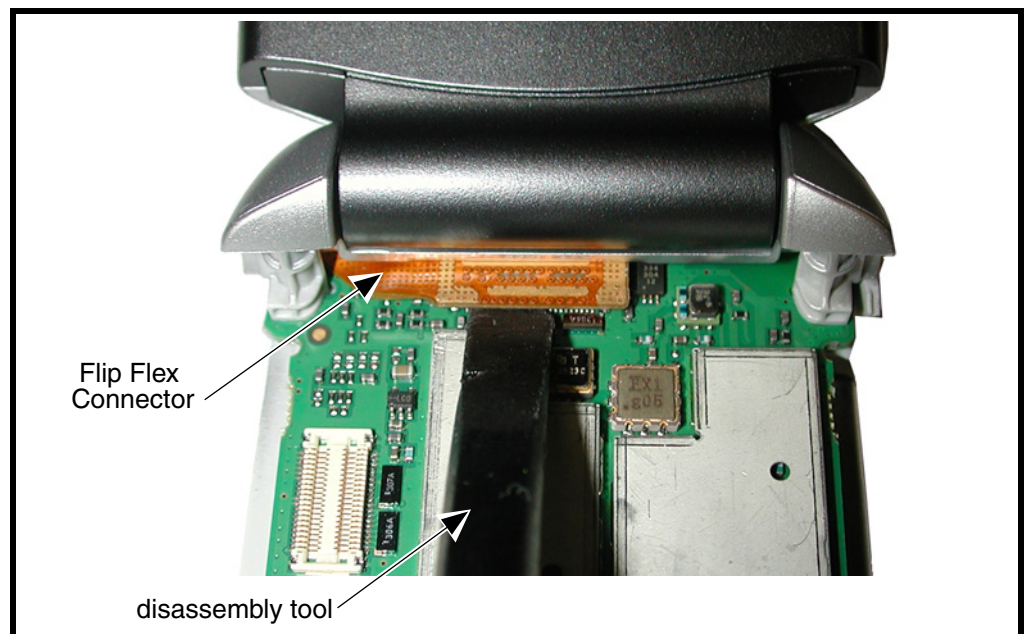

0322160

Figure 17. Removing the Flip Assembly Flex Connector

3. Use the T6 driver to remove the two flip assembly screws. Set the screws aside for reuse (See Figure 18).

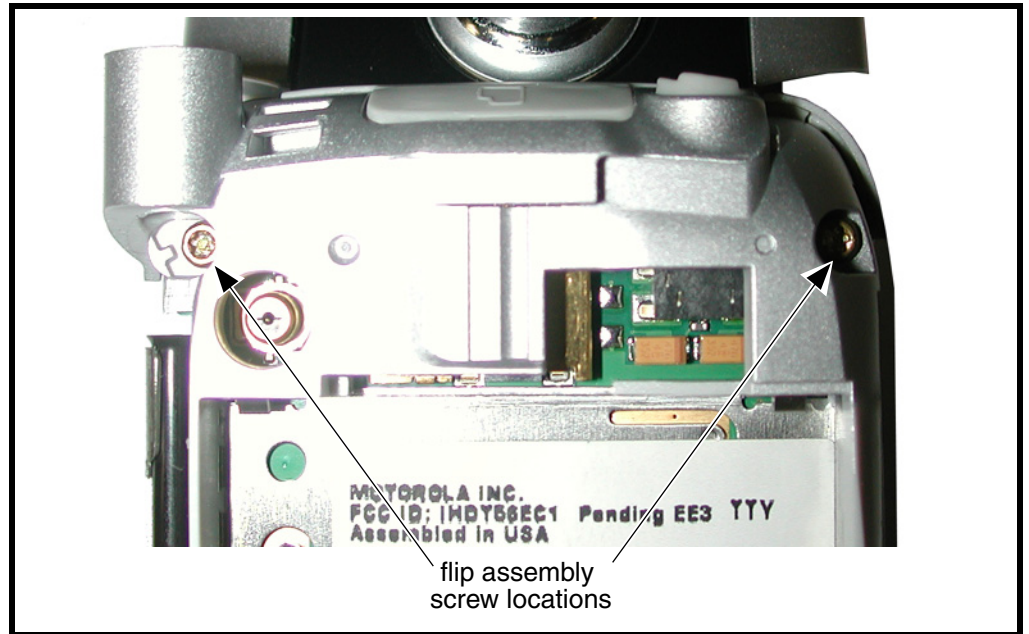

Figure 18. Removing the Flip Assembly Screws

4. Carefully separate the flip assembly from the transceiver board and rear housing assembly.



This product contains static-sensitive devices. Use anti-static handling procedures to prevent electrostatic discharge (ESD) and component damage.

5. Turn the transceiver board and rear assembly over and lift the transceiver board away from the rear housing..

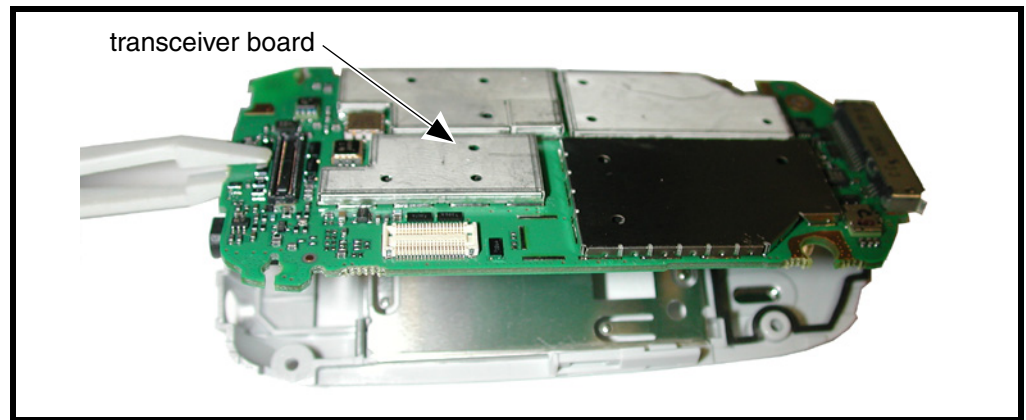

0322160

Figure 19. Removing the Transceiver Board

6. To replace, align the transceiver board to the rear housing assembly and lower it into place on the rear housing.
7. With the flip assembly knuckles in the "flip open" position, align the flip assembly flex connector to the transceiver board.
8. Connect the flip assembly flex connector to its socket on the transceiver board.
9. Align the flip assembly screw bosses to the screw holes on the transceiver board.
10. Hold the assembly together and insert the flip assembly screws into the rear housing assembly and tighten to 1.25 inch-pounds.
11. Replace the keyboard stiffener, speaker cover, keypad bezel, antenna, battery, and battery cover as described in the procedures.

Removing and Replacing the Flip Display Lens

1. Remove the battery cover, battery, antenna, keypad bezel, speaker cover, keyboard stiffener, flip assembly, and transceiver board as described in the procedures.
2. Insert a small knife blade into the seam between the main lens and the flip sleeve edge and pry up the main lens edge (see Figure 20).



0403700

Figure 20. Removing the Flip Display Lens

3. Insert the flat end of the disassembly tool into the gap created by the knife blade and separate the display lens from the flip assembly.
4. To replace, align the display lens to the flip assembly. Expose the display lens adhesive. Carefully press the display lens into position on the flip assembly.
5. Replace the transceiver board and flip assembly, keypad stiffener, speaker cover, keypad bezel, antenna, battery, and battery cover as described in the procedures.

Removing and Replacing the Flip Assembly Sleeve

1. Remove the battery cover, battery, antenna, keypad bezel, speaker cover, keyboard stiffener, flip assembly, transceiver board, and flip display lens as described in the procedures.
2. Grasp the flip assembly and pull firmly as indicated by the red arrows to remove the flip assembly sleeve (See Figure 21).

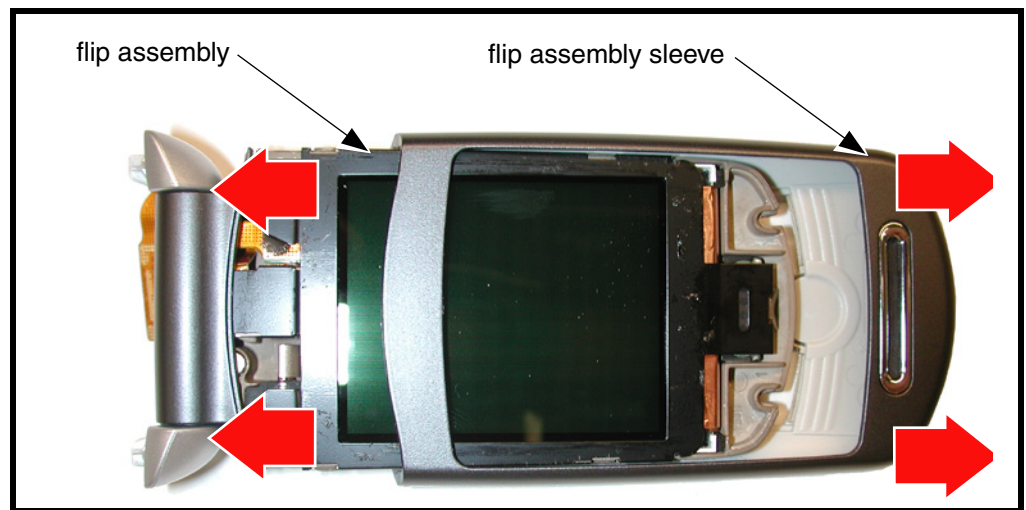

0403690

Figure 21. Removing the Flip Assembly Sleeve.

3. To replace, insert the flip assembly into the flip assembly sleeve and push firmly until the flip assembly is fully inserted into the flip assembly sleeve.
4. Replace the flip display lens, transceiver board, flip assembly, keyboard stiffener, speaker cover, keypad bezel, antenna, battery, and battery cover as described in the procedures.

Removing and Replacing the Flip Knuckle

1. Remove the battery cover, battery, antenna, keypad bezel, speaker cover, keyboard stiffener, flip assembly, transceiver board, flip display lens, and flip assembly sleeve as described in the procedures.



The flexible printed cable (FPC) (flex) is easily damaged. Exercise extreme care when handling.

2. Remove the knuckle by removing the hinge assembly side followed by the side where the flex is routed.
3. Carefully slide the display flex through the knuckle. Avoid damage to the display flex (see Figure 22).



Figure 22. Removing the Knuckle.

040371o

Removing the Display Bezel

1. Remove the battery cover, battery, antenna, keypad bezel, speaker cover, keyboard stiffener, flip assembly, transceiver board, flip display lens, flip assembly, flip assembly sleeve, and flip knuckle as described in the procedures.



The flexible printed cable (FPC) (flex) is easily damaged. Exercise extreme care when handling.

2. Use the metal tweezers to release the five latches in the sequence shown (see Figure 23).

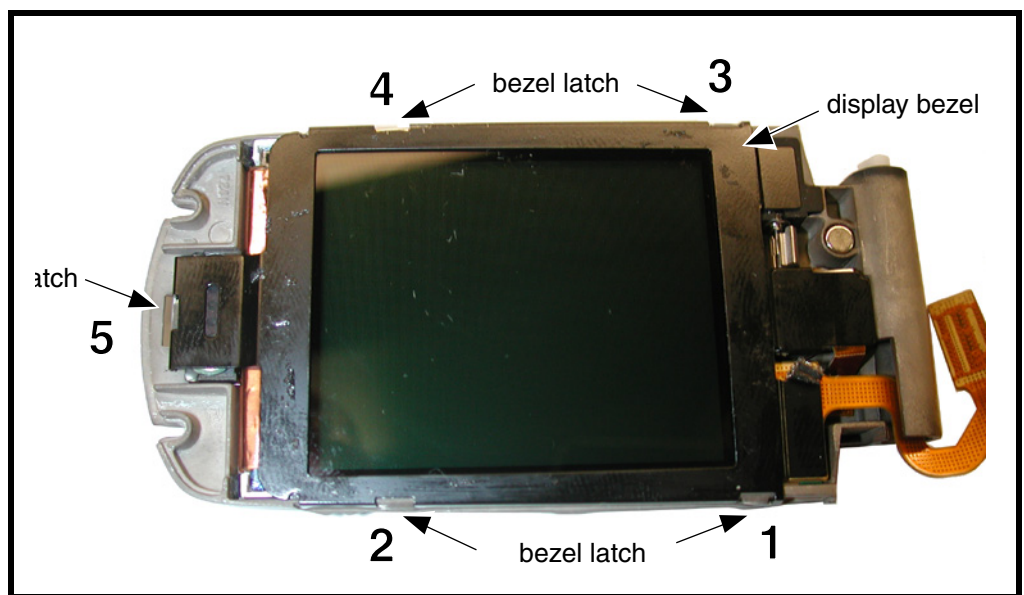

0322180

Figure 23. Removing the Display Bezel

3. To replace, align the connector with its socket on the transceiver board.
4. Gently press the flex connector into position onto the flex connector socket.
5. Lower the display bezel over the display module. Gently and firmly press the latches into position. Ensure all the latches are engaged.
6. Replace the flip knuckle, flip assembly sleeve, flip assembly, flip display lens, transceiver board, flip assembly, keyboard stiffener, speaker cover, keypad bezel, antenna, battery, and battery cover as described in the procedures.

Removing the Display Module

1. Remove the battery cover, battery, antenna, keypad bezel, speaker cover, keyboard stiffener, flip assembly, transceiver board, flip display lens, flip assembly, flip assembly sleeve, flip knuckle, and display module as described in the procedures.
2. Use the disassembly tool to disconnect the flex connector from the display module assembly (see Figure 24).
3. Carefully, lift the display module up and away from the remainder of the flip assembly.

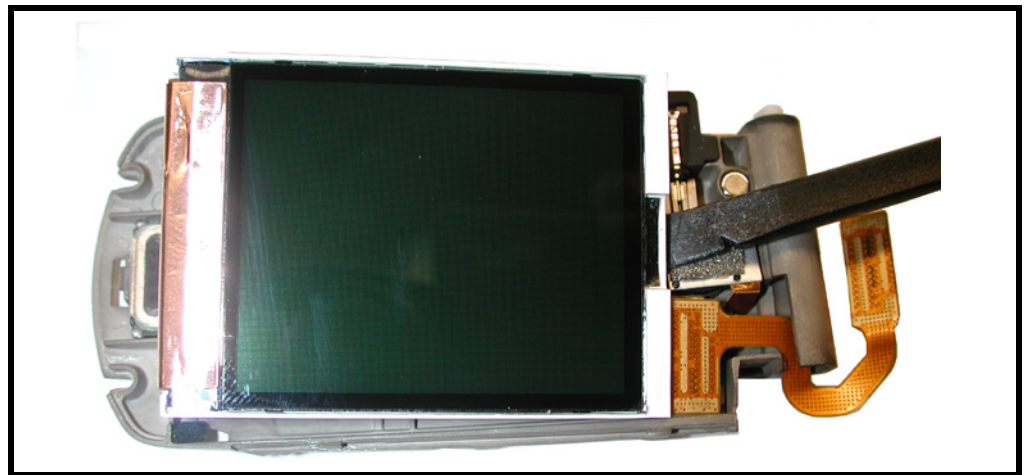

0322330

Figure 24. Removing the Display Module

4. To replace, seat the display module back into the flip assembly.
5. Carefully re-connect the flex connector.
6. Replace the display bezel, flip knuckle, flip assembly sleeve, flip assembly, flip display lens, transceiver board, flip assembly, keyboard stiffener, speaker cover, keypad bezel, antenna, battery, and battery cover as described in the procedures.

Removing and Replacing the Keypad

1. Remove the antenna, battery cover, battery, rear housing assembly, flex connector, and transceiver board assembly as described in the procedures.
2. Use the plastic tweezers to lift the keypad from the front housing as shown in Figure 25.

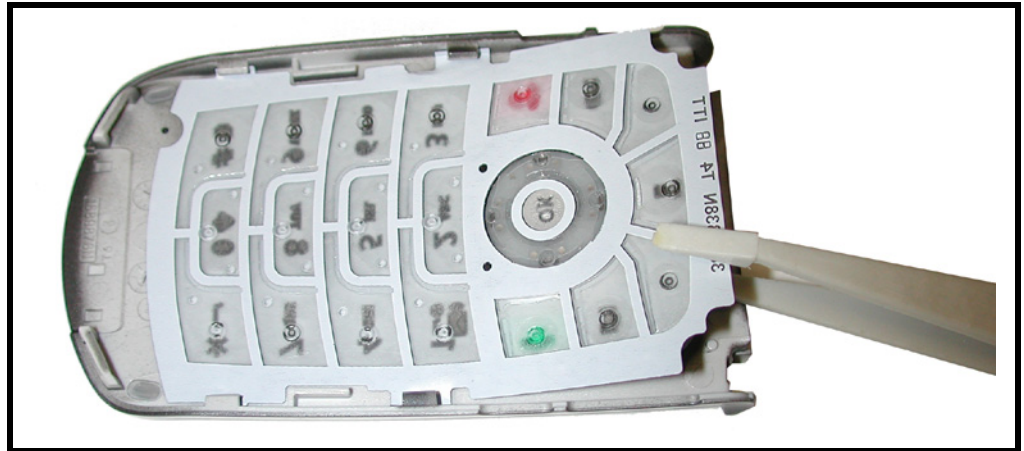

0322200

Figure 25. Removing the Keypad

3. To replace, insert the keypad into the front housing, ensuring the keys align properly with the openings in the front housing.
4. Replace the transceiver board, rear housing assembly, antenna, battery, and battery housing as described in the procedures.

Removing the Motor/Vibrator Assembly

1. Remove the battery cover, battery, antenna, keypad bezel, speaker cover, keyboard stiffener, keypad flex, flip flex connector, transceiver board, flip assembly, flip display lens, flip sleeve, flip display bezel, display module assembly as described in the procedures.
2. Use the flat edge of the disassembly tool to remove the motor/vibrator assembly from the flip housing (see Figure 26).

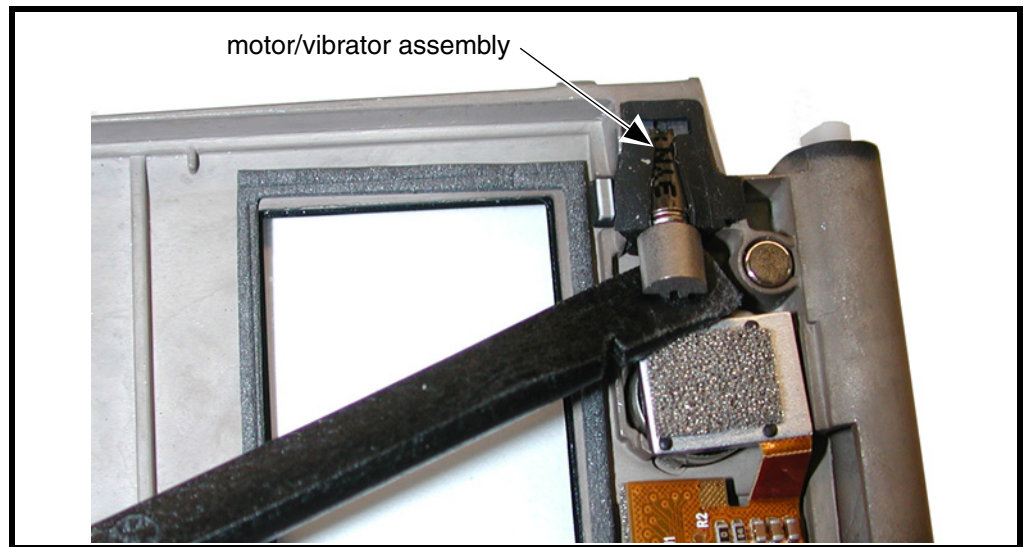

0322320

Figure 26. Removing the Motor/Vibrator Assembly

- 3.

Phone Identification

Personality Transfer

A personality transfer is required when a phone is express exchanged or when the main board is replaced. Personality transfers reproduce the customer's original personalized details such as menu and stored memory such as phone books, or even just program a unit with basic user information such as language selection.

Identification

Each Motorola CDMA phone is labeled with a variety of identifying numbers. Figure 27 describes the current identifying labels.

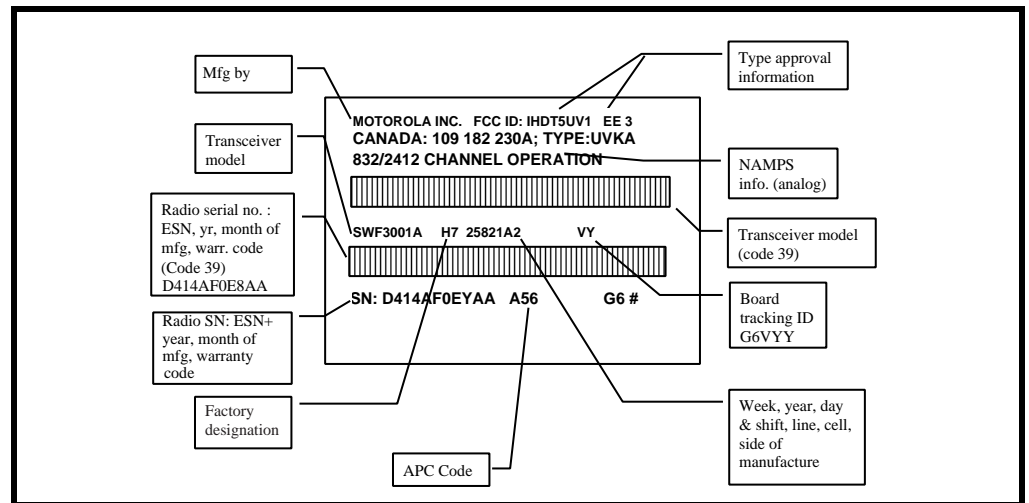

020463o

Figure 27. CDMA Telephone Identification Label

Troubleshooting

Table 2. Level 1 and 2 Troubleshooting Chart

Symptom	Probable Cause	Verification and Remedy
1. Telephone will not turn on or stay on.	a) Battery either discharged or defective.	Measure battery voltage across a 50 ohm (>1 Watt) load. If the battery voltage is <3.25 Vdc, recharge the battery using the appropriate battery charger. If the battery will not recharge, replace the battery. If battery is not at fault, proceed to b.
	b) Battery connectors open or misaligned.	Visually inspect the battery connectors on both the battery and the telephone. Realign and, if necessary, either replace the battery or refer to a Level 3 Service Center for the battery connector replacement. If battery connectors are not at fault, proceed to c.
	c) Transceiver board defective.	Remove the transceiver board. Substitute a known good transceiver board and temporarily reassemble the unit. Press the PWR button; if unit turns on and stays on, disconnect the dc power source and reassemble the telephone with the new transceiver board. Verify that the fault has been cleared. If the fault has not been cleared then proceed to d.
	d) keyboard assembly failure.	Replace the keyboard assembly. Temporarily connect a +3.6 Vdc supply to the battery connectors. Depress the PWR button. If unit turns on and stays on, disconnect the dc power source and reassemble with the new keyboard assembly.
2. Telephone exhibits poor reception or erratic operation such as calls frequently dropping or weak or distorted audio.	a) Antenna assembly defective.	Check to make sure that the antenna pin is properly connected to the transceiver board assembly. If connected properly, substitute a known good antenna. If the fault is still present, proceed to b.
	b) Transceiver board defective.	Replace the transceiver board (refer to 1c). Verify that the fault has been cleared and reassemble the unit with the new transceiver board.
3. Display is erratic, or provides partial or no display.	a) Connections to or from transceiver board defective.	Check general condition of flex and flex connector. If the flex and connector are good, check that the flex connector is fully connected. If not, check connector to transceiver board connections. If faulty connector, replace the transceiver board. If connector is not at fault, proceed to b.
	b) Flip assembly defective.	Temporarily replace the flip assembly with a known good assembly. If fault has been cleared, reassemble with the new flip assembly. If fault not cleared, proceed to c.
	c) Transceiver board assembly defective.	Replace the transceiver board (refer to 1c). Verify that the fault has been cleared and reassemble the unit with the new transceiver board.
4. Incoming call alert transducer audio distorted or volume is too low.	Faulty transceiver board assembly.	Replace the transceiver board (refer to 1c). Verify that the fault has been cleared and reassemble the unit with the new transceiver board.
5. Telephone transmit audio is weak. (usually indicated by called parties complaining of difficulty in hearing voice).	a) Microphone connections to the transceiver board assembly defective.	Gain access to the microphone as described in the procedures. Check connections. If connector is faulty proceed to c; if the connector is not at fault, proceed to b.

Table 2. Level 1 and 2 Troubleshooting Chart (Continued)

Symptom	Probable Cause	Verification and Remedy
	b) Microphone defective.	Gain access to microphone. Disconnect and substitute a known good microphone. Place a call and verify improvement in transmit signal as heard by called party. If good, reassemble with new microphone. If microphone is not at fault, reinstall original microphone and proceed to c.
	c) Transceiver board assembly defective.	Replace the transceiver board assembly (refer to 1c). Verify that the fault has been cleared and reassemble the unit with the new transceiver board assembly.
6. Receive audio from earpiece speaker is weak or distorted.	a) Connections to or from transceiver board assembly defective.	Gain access to the transceiver board assembly as described in the procedures. Check flex and the flex connector from the flip assembly to the transceiver board assembly. If flex is at fault, replace flip assembly. If flex connector is at fault, proceed to d. If connection is not at fault, proceed to b.
	b) Flip assembly defective.	Temporarily replace the flip assembly with a known good assembly. If fault has been cleared, reassemble with the new flip assembly. If fault not cleared, proceed to c.
	c) Antenna assembly defective.	Check to make sure the antenna is installed correctly. If the antenna is installed correctly, substitute a known good antenna assembly. If this does not clear the fault, reinstall the original antenna assembly and proceed to d.
	d) Transceiver board assembly defective.	Replace the transceiver board assembly (refer to 1c). Verify that the fault has been cleared and reassemble with the new transceiver board assembly.
7. Phone does not sense when flip is opened or closed (usually indicated by inability to answer incoming calls by opening the flip, or inability to make outgoing calls).	a) Flip assembly defective.	Temporarily replace the flip assembly with a known good assembly. If fault has been cleared, reassemble with the new flip assembly. If fault not cleared, proceed to b.
	b) Transceiver board assembly defective.	Replace the transceiver board assembly (refer to 1c). Verify that the fault has been cleared and reassemble the unit with the new transceiver board assembly.
8. Vibrator feature not functioning.	Transceiver board assembly defective.	Replace the transceiver board assembly (refer to 1c). Verify that the fault has been cleared and reassemble the unit with the new transceiver board assembly.
9. Internal Charger not working.	Faulty charger circuit on transceiver board assembly.	Test a selection of batteries in the rear pocket of the desktop charger. Check LED display for the charging indications. If these are charging properly, then the internal charger is at fault. Replace the transceiver board assembly (refer to 1c). Verify that the fault has been cleared and reassemble the unit with the new transceiver board assembly.
11. No or weak audio when using headset.	a) Headset not fully pushed home.	Ensure the headset plug is fully seated in the jack socket. If fault not cleared, proceed to b.
	b) Faulty jack socket on transceiver board assembly.	Replace the transceiver board assembly (refer to 1c). Verify that the fault has been cleared and reassemble the unit with the new transceiver board assembly.

Programming: Software Upgrade and Flexing

Contact your local technical support engineer for information about equipment and procedures for flashing and flexing.

Related Publications

Motorola A840 CDMA User Guide, English/Spanish 6809482A51 (SJJN6405A)

Exploded View Diagram

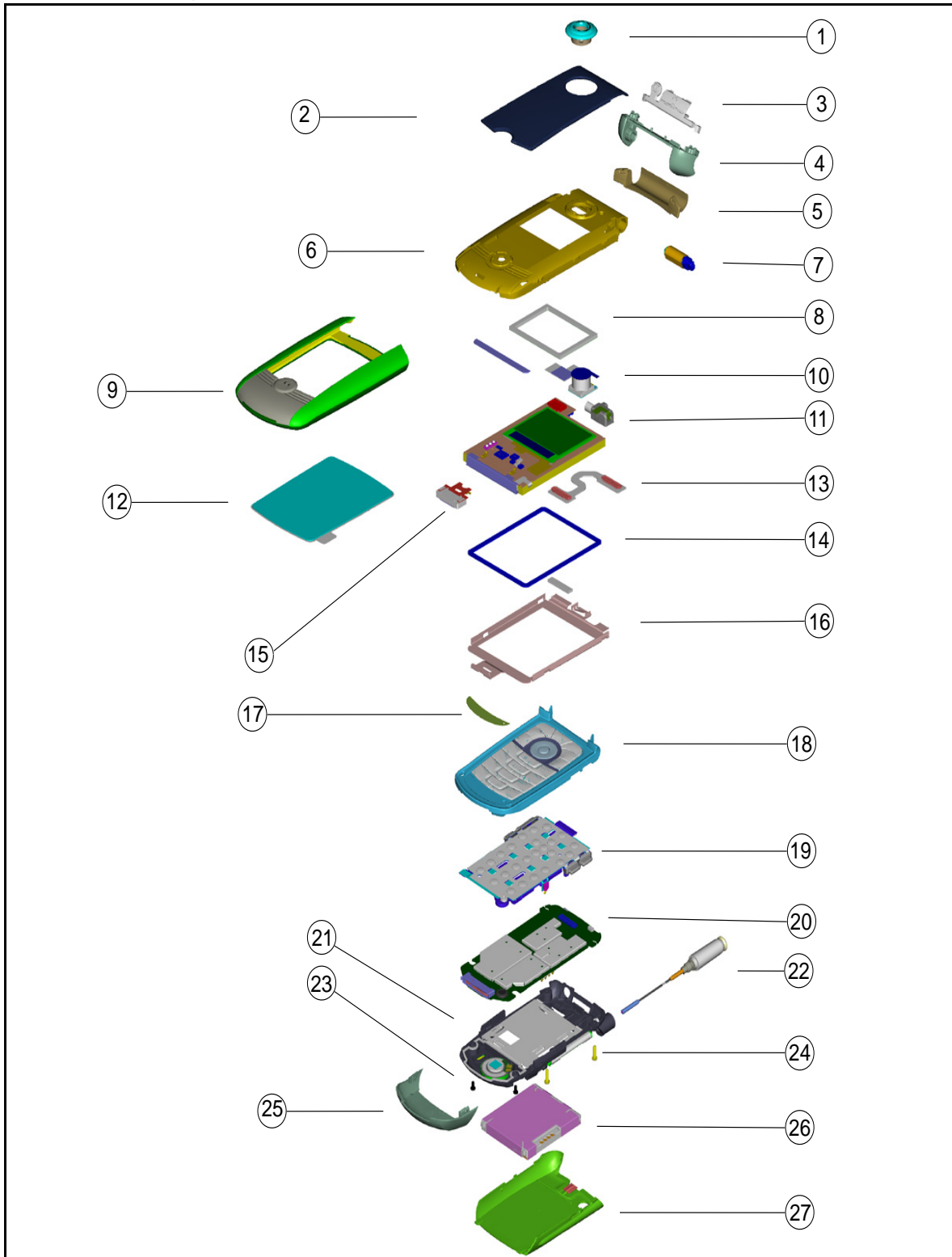

Figure 28. Exploded View

Exploded View Parts List

Table 3. Exploded View Parts List

Item Number	Motorola Part Number	Description
1	1389819N03	camera bezel
2	6189691N02	CLI lens
3	7589314N02	flip stop grommet
4	1589315N04	knuckles
5	1589875N04	Barrel cover
6	0789724N01	Magnesium frame
7	5587736N01	Hinge assembly
8	3289412N02	CLI display gasket
9	1589700N04	Flip sleeve assembly
10	8489850N02	Camera assy
11	5989943N01	Vibrator motor assy
12	7289424N01	Display module
13	6189690N05	Main lens
14	8489450N02	Hinge flex
15	8490009N01	Speaker assy
16	3289413N04	Main display gasket
17	0789918N02	Display bezel
18	5402393T02	Label
19	1589331N02	Keypad bezel assy
20	0187521Y03	keyboard assembly
21		transceiver PC Board Assy
22	0789414N02	Rear endo assy
23	8587488Y01	Antenna
24	0389469N02	Screw, stiffener
25	0387791L01	Screw, knuckle
26	1589318N03	Speaker cover
27	SNN5695A SNN5615	battery 720 mAh battery 1140 mAh
28	1589333N04	battery cover



There is a danger of explosion if the Lithium Ion battery pack is replaced incorrectly. Replace only with the same type of battery or equivalent as recommended by the battery manufacturer. Dispose of used batteries according to the manufacturer's instructions.

Accessories

Table 4. Accessories

Description	Part Number
Power Solutions	
Battery Slim Lilon (720mAh)	TBD
Battery High Performance (1440mAh)	SNN5615A
Travel Charger Linear U.S.	SPN4992
Travel Charger Mid Rate U.S. New ID	SPN5037
Travel Charger Rapid U.S. (non-leakage)	SPN5049
In-Vehicle Solutions	
Bluetooth Car Kit	S9642
Self Install HF Retractable (Razorbill)	SYN0613
Professional Install Car Kit (Junction Box Only)	S9950
HUC for PCC	TBD
Low Tier VPA Mid rate	
VPA Verizon Exclusive Rapid	SYN9901
Vehicle Power Adapter, New ID Rapid	SYN0707
Audio & Connectivity	
Paladin Bluetooth Headset	SYN9826A
Caller ID Bluetooth Headset	TBD
Quadrant Bluetooth Speaker	TBD
Qwerty Bluetooth Keyboard	TBD
Platform Stereo Headset	TBD
FM Stereo Headset	SYN8609
Retractable Headset (new customizable)	SYN9050
One Touch Headset (new customizable)	SYN9351
Mono Headset Black	SYN8390B
Mono Headset Silver	AAYN4264A
Mono Headset (new customizable)	SYN9350
Over the Ear Headset	SYN8908
Neck Loop headset	SYN7875
T-Flash Card 16 meg	SYN0940
T-Flash Card 32 Meg	SYN0941
T-Flash Card 64 meg	SYN0942
T-Flash card 128 meg	SYN0943
T-Flash Card (32 Meg) and T-Flash to SD Adaptor in Jewel Case	SYN0941A
T-Flash to SD adaptor	SYN0893A
USB 2.0 Card Reader	SYN1045A
Mobile Phone Tools Phase II - USB	S9752B
Mobile Phone Tools Phase II - CD ROM	SVN4776B
Consumer Personalization	
Carry Cases	TBD
Lanyard	SYN9490A
Holster	TBD
Belt Clip	SYN8763

Block Diagram

A840 / A860

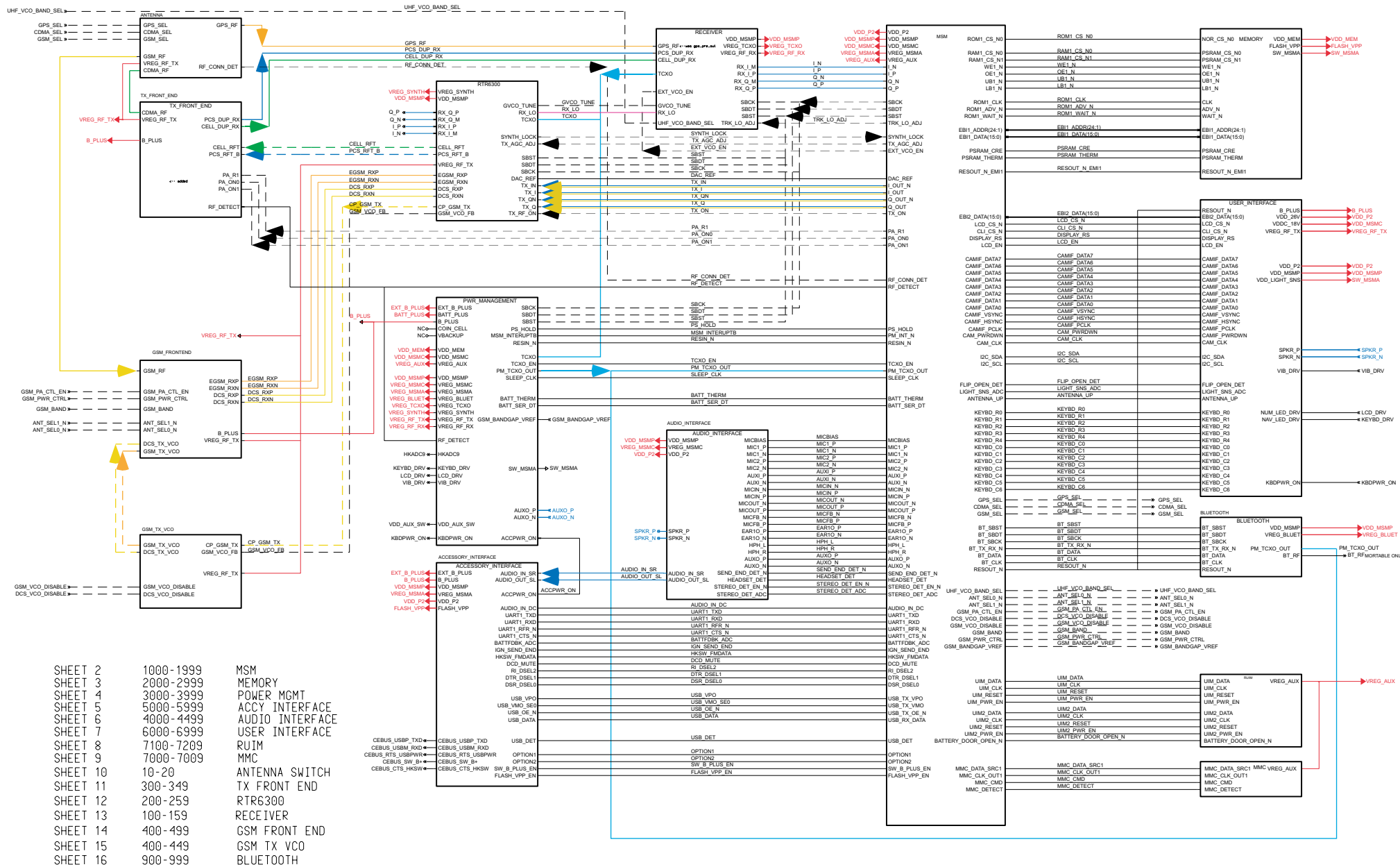

SHEET 2	1000-1999	MSM
SHEET 3	2000-2999	MEMORY
SHEET 4	3000-3999	POWER MGMT
SHEET 5	5000-5999	ACCY INTERFACE
SHEET 6	4000-4499	AUDIO INTERFACE
SHEET 7	6000-6999	USER INTERFACE
SHEET 8	7100-7209	RJ1M
SHEET 9	7000-7009	MMC
SHEET 10	10-20	ANTENNA SWITCH
SHEET 11	300-349	TX FRONT END
SHEET 12	200-259	RTR6300
SHEET 13	100-159	RECEIVER
SHEET 14	400-499	GSM FRONT END
SHEET 15	400-449	GSM TX VCO
SHEET 16	900-999	BLUETOOTH

CEBUS_USBP_TXD	CEBUS_USBP_TXD	USB_DET
CEBUS_USBM_RXD	CEBUS_USBM_RXD	OPTION0
CEBUS_RTS_USBPWR	CEBUS_RTS_USBPWR	OPTION1
CEBUS_SW_B	CEBUS_SW_B	OPTION2
CEBUS_CTS_HKSW	SW_B_PLUS_EN	FLASH_VPP_EN

This document is property of MOTOROLA and it should be return if not used. Distribution and copies of this document are not allowed with out MOTOROLA approval.

MOTOROLA CONFIDENTIAL PROPRIETARY

BOARD - P4

Antenna Schem

A840 / A860

ANTENNA/SWITCH
REF 10-20

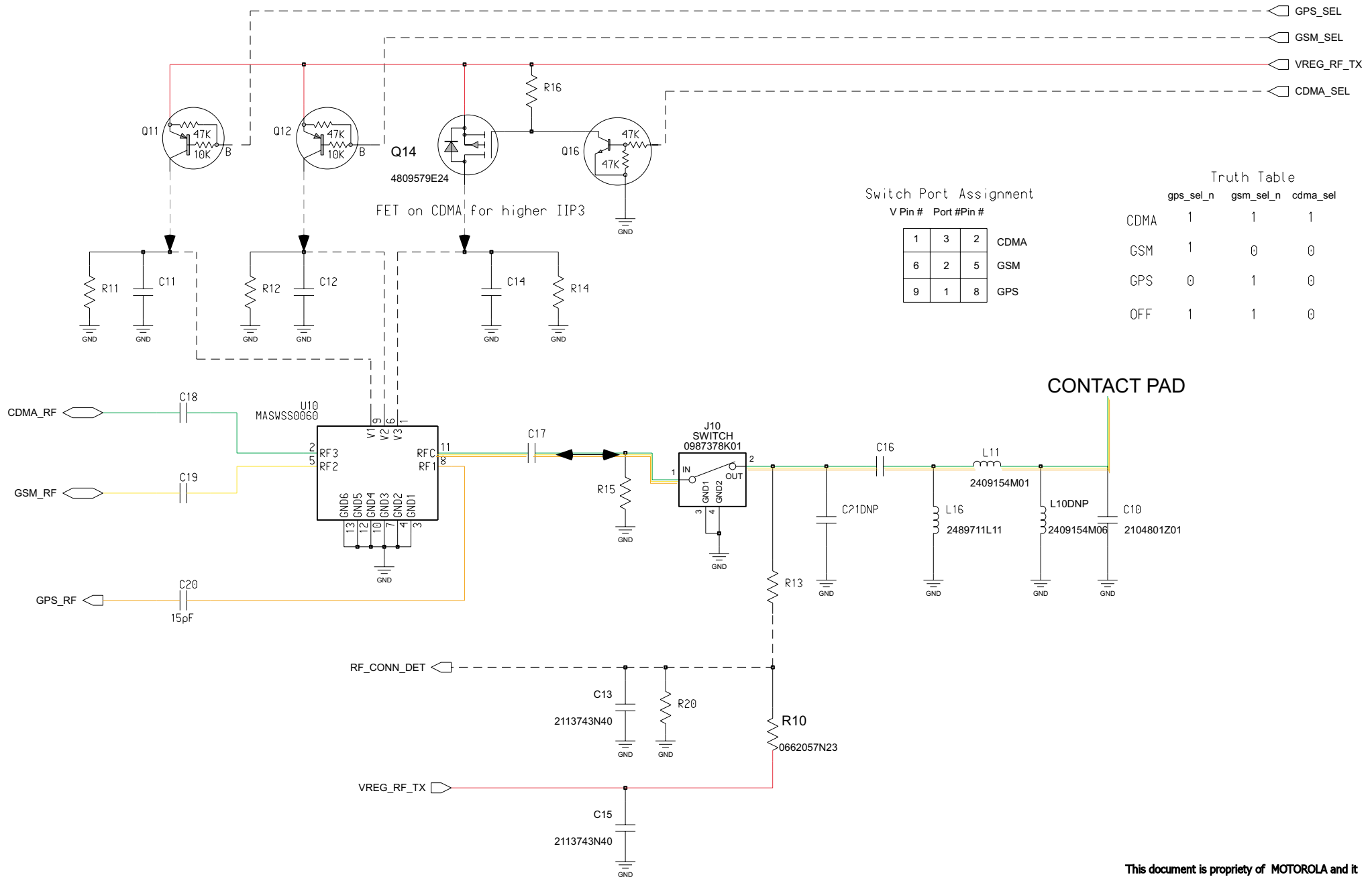

Switch Port Assignment
V Pin # Port #Pin #

1	3	2	CDMA
6	2	5	GSM
9	1	8	GPS

Truth Table

	gps_sel_n	gsm_sel_n	cdma_sel
CDMA	1	1	1
GSM	1	0	0
GPS	0	1	0
OFF	1	1	0

CONTACT PAD

This document is propriety of MOTOROLA and it should be return if not used .
Distribution and copies of this document are not allowed with out MOTOROLA approval.

MOTOROLA CONFIDENTIAL PROPRIETARY

BOARD - P4

Antenna Circuit

A840 / A860

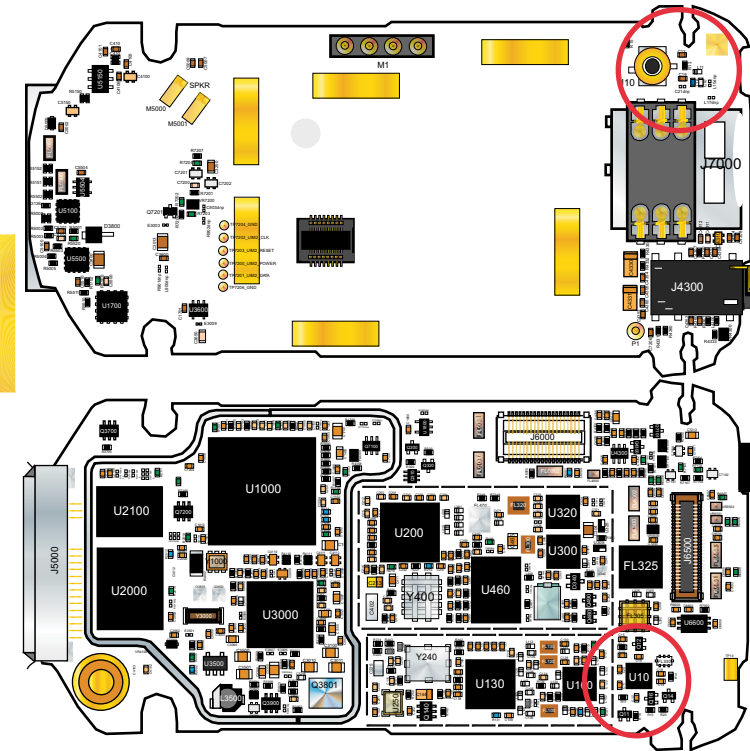
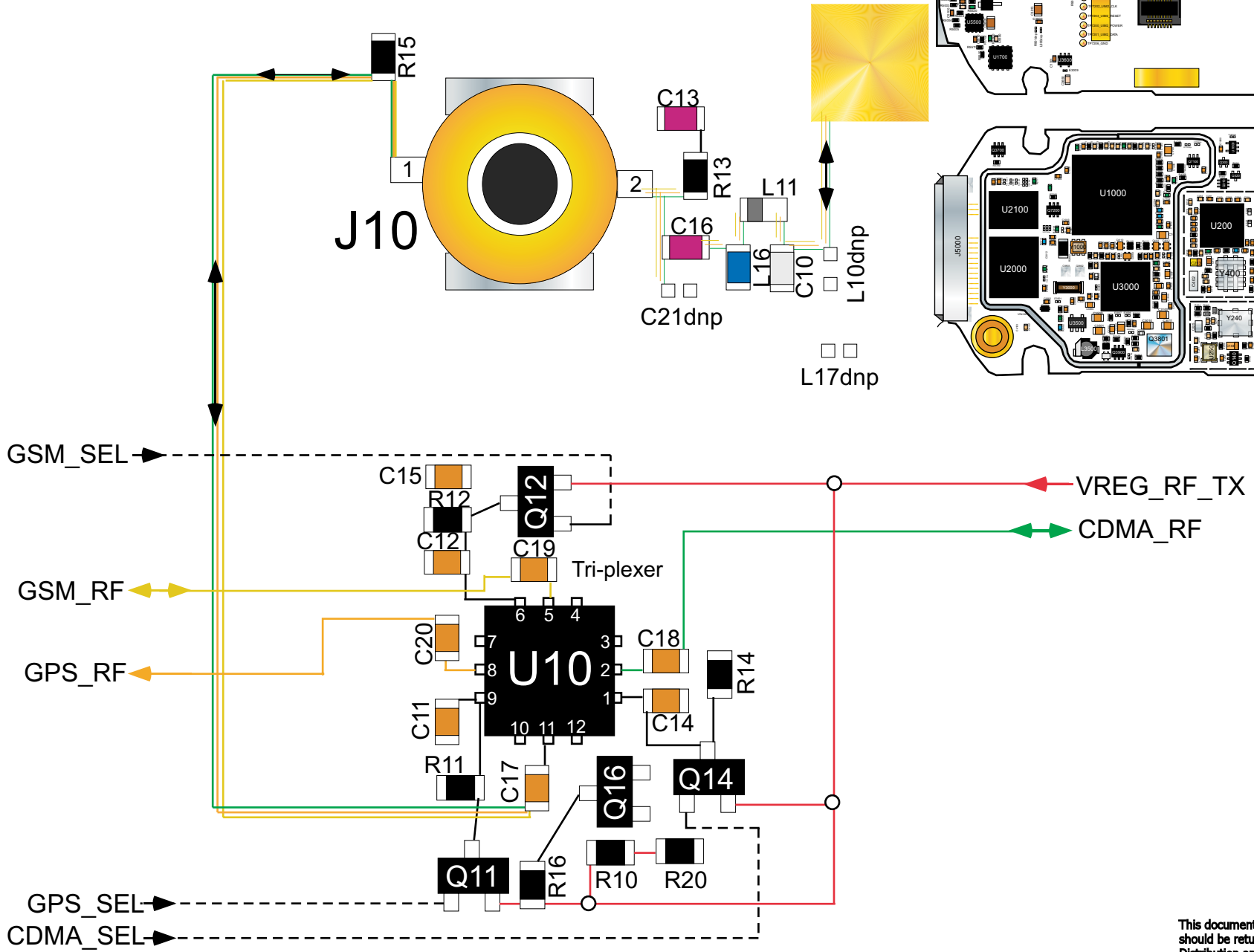

This document is propriety of MOTOROLA and it should be return if not used .
Distribution and copies of this document are not allowed with out MOTOROLA approval.

MOTOROLA CONFIDENTIAL PROPRIETARY

BOARD - P4

Receiver CDMA Schem

A840 / A860

RECEIVER
REF 100-159

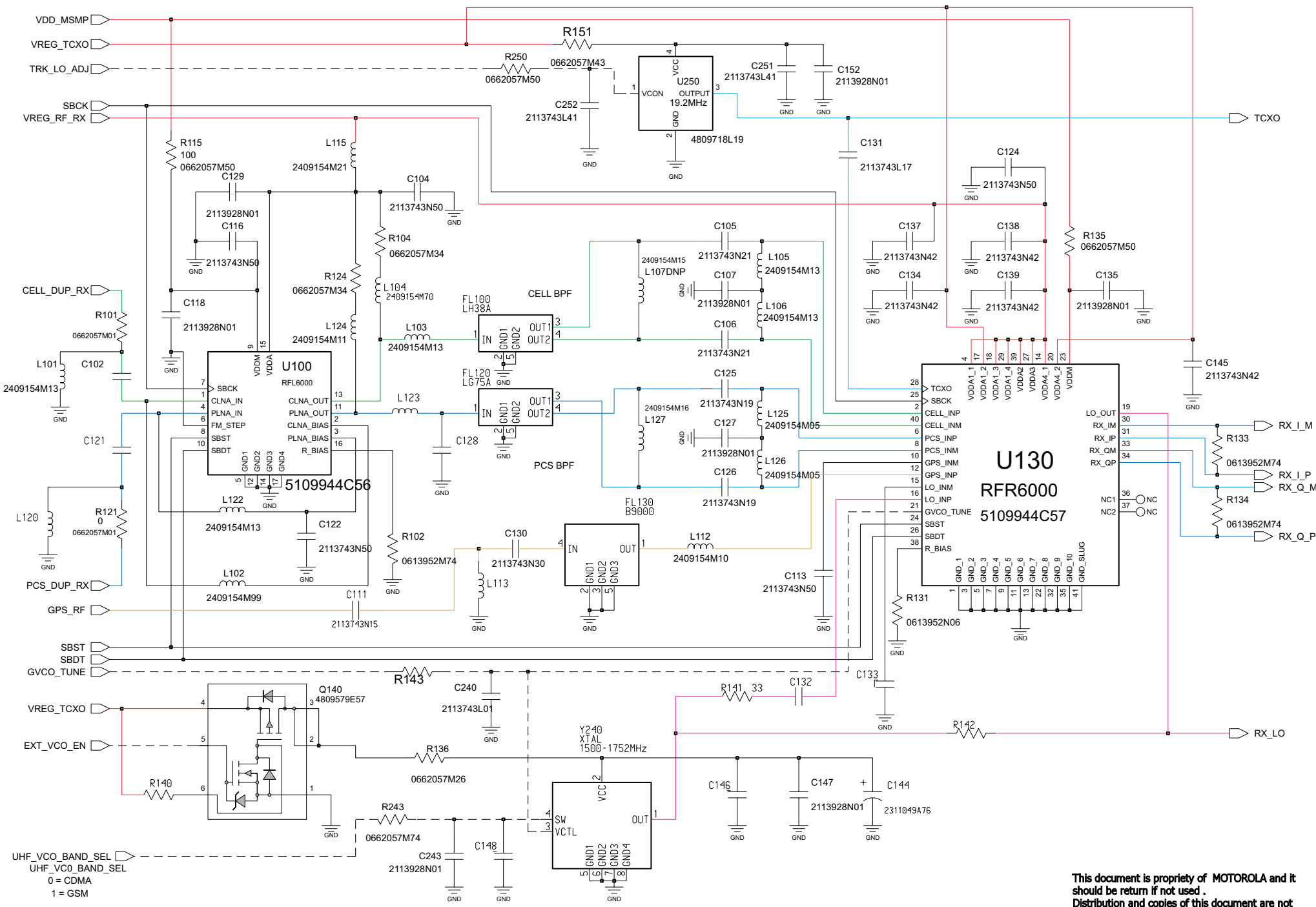

This document is propriety of MOTOROLA and it should be return if not used . Distribution and copies of this document are not allowed with out MOTOROLA approval.

MOTOROLA CONFIDENTIAL PROPRIETARY

BOARD - P4

RX CDMA Circuit

A840 / A860

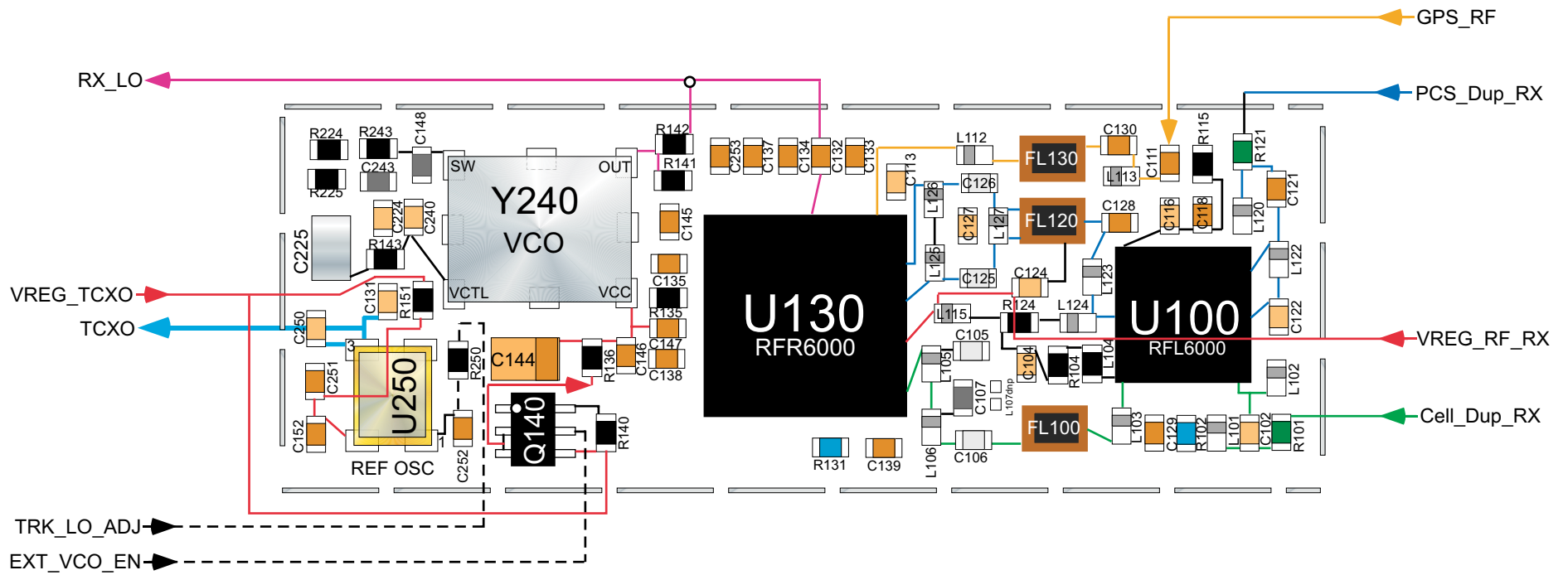
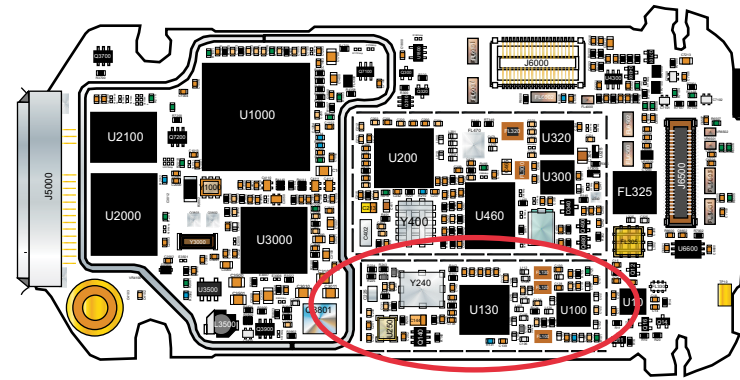

This document is property of MOTOROLA and it should be return if not used .
Distribution and copies of this document are not allowed with out MOTOROLA approval.

MOTOROLA CONFIDENTIAL PROPRIETARY

BOARD - P4

GSM Front End Schem

A840 / A860

GSM_FRONTEND
REF 450-499

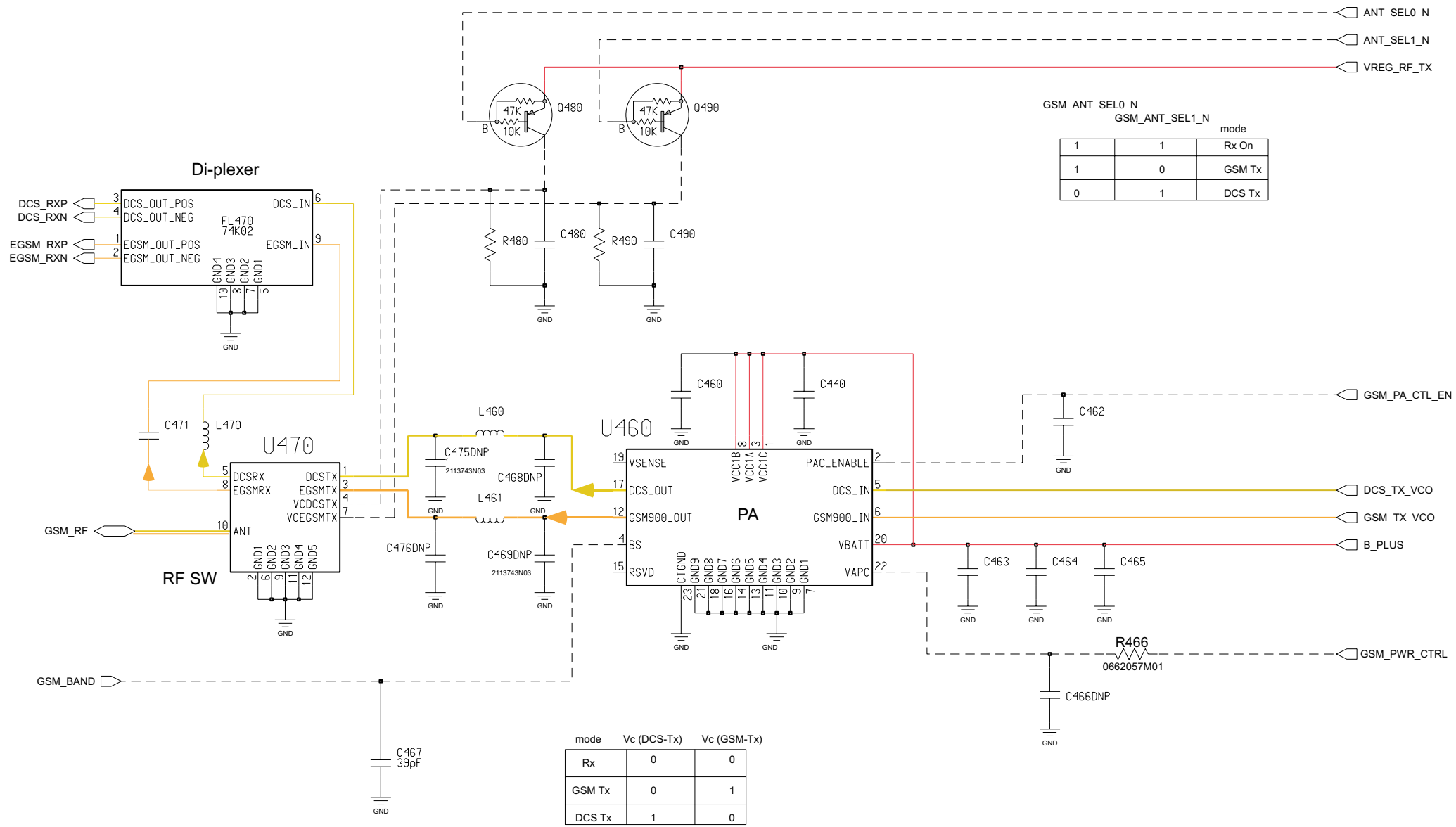

This document is propriety of MOTOROLA and it should be return if not used .
Distribution and copies of this document are not allowed with out MOTOROLA approval.

MOTOROLA CONFIDENTIAL PROPRIETARY

BOARD - P4

GSM Front End Circuit

A840 / A860

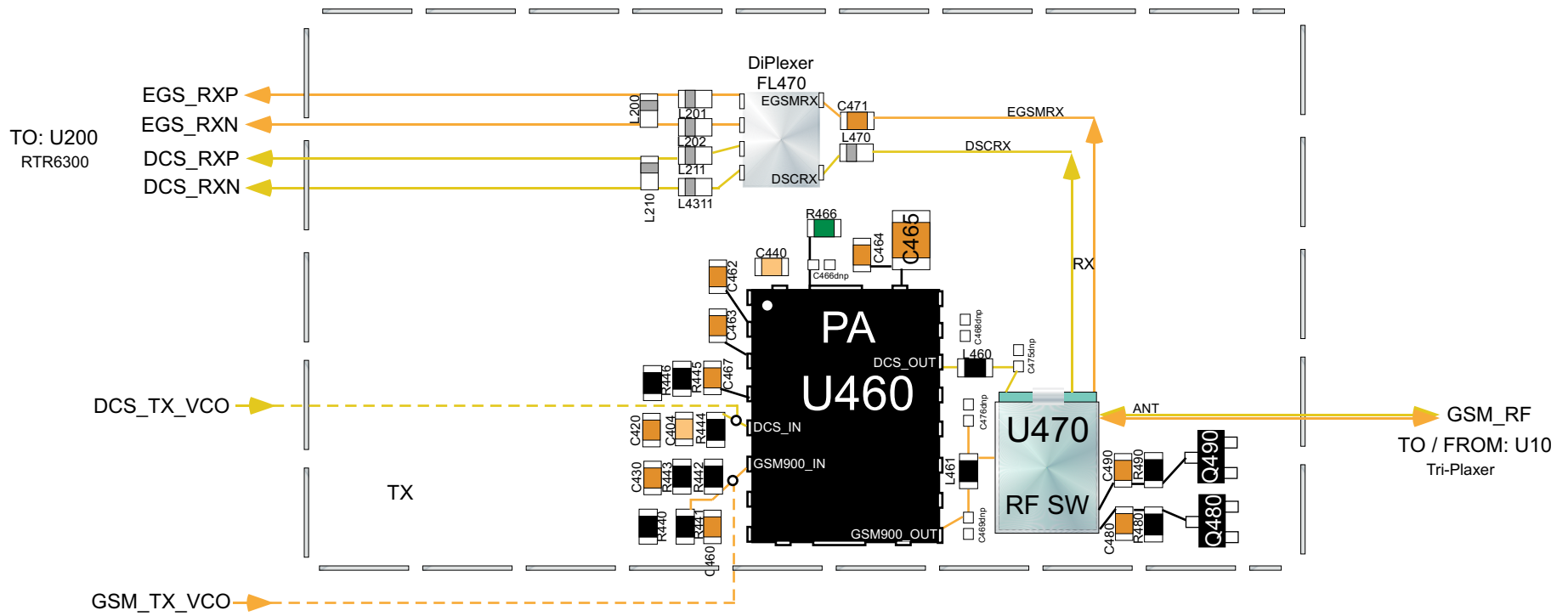
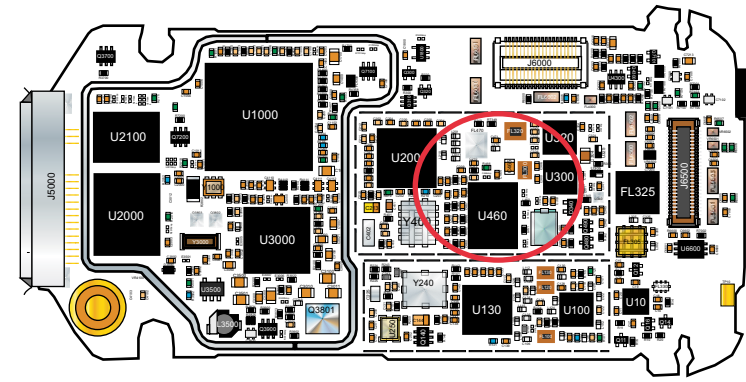

This document is property of MOTOROLA and it should be return if not used .
Distribution and copies of this document are not allowed with out MOTOROLA approval.

MOTOROLA CONFIDENTIAL PROPRIETARY

BOARD - P4

TX Front End Schem

A840 / A860

TX FRONT END
REF 300-349

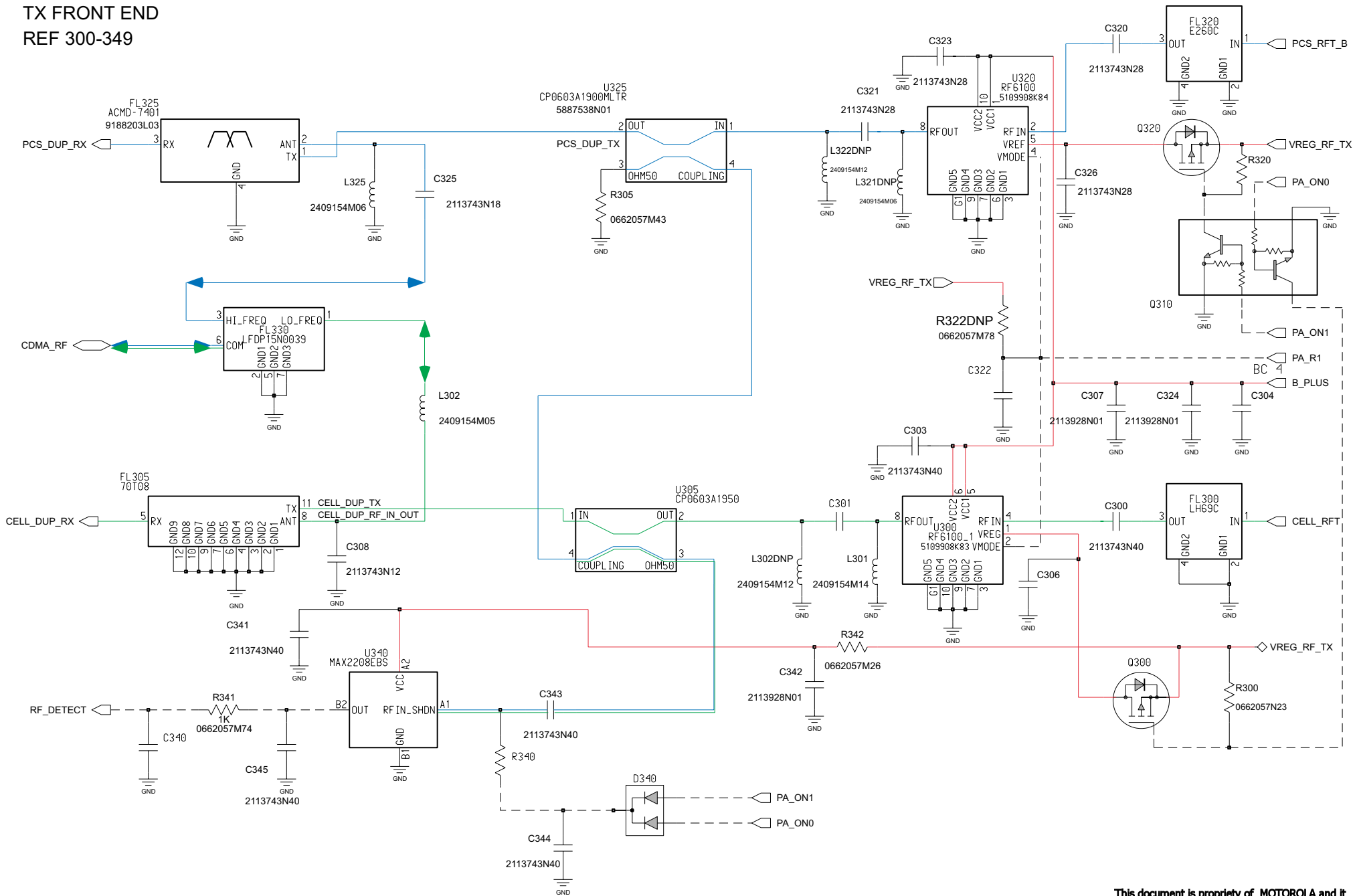

This document is propriety of MOTOROLA and it should be return if not used . Distribution and copies of this document are not allowed with out MOTOROLA approval.

GSM_TX_VCO Schem

A840 / A860

GSM_TX_VCO
REF 400-449

	GSM_VCO_DISABLE SW1	DCS_VCO_DISABLE SW2
Low Band	0	1
High Band	1	0
No Workie	1	1

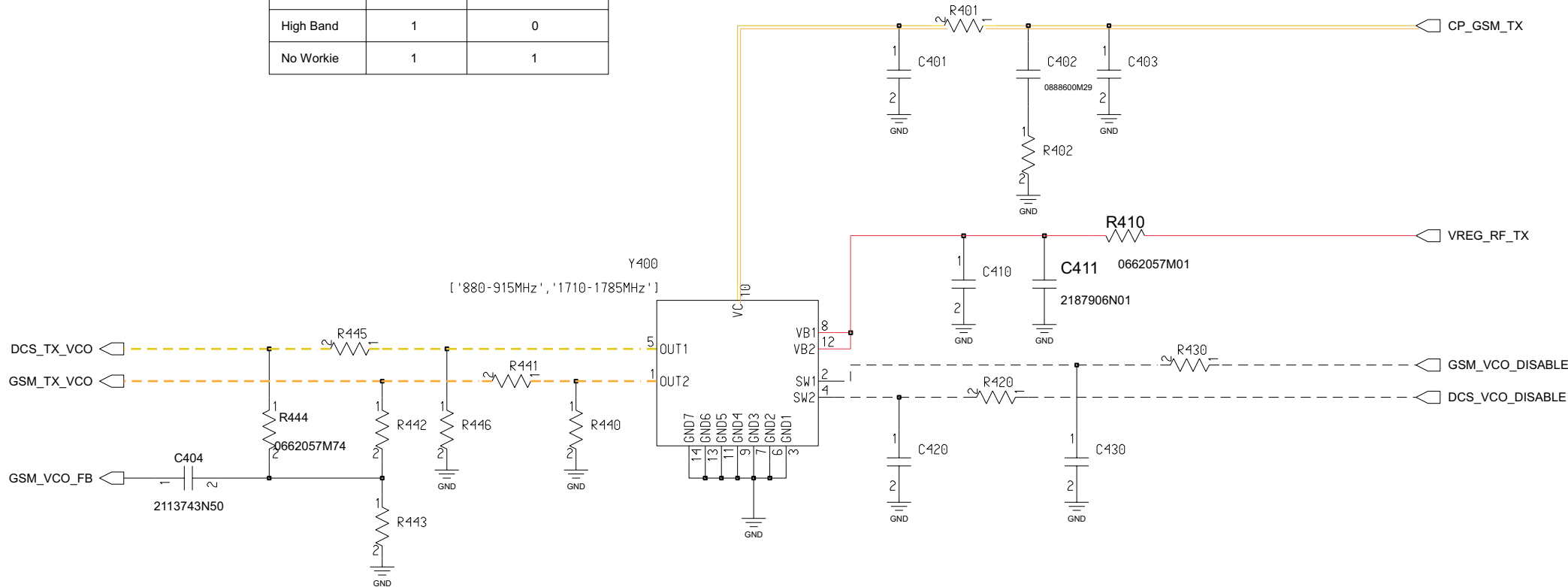

This document is propriety of MOTOROLA and it should be return if not used .
Distribution and copies of this document are not allowed with out MOTOROLA approval.

MOTOROLA CONFIDENTIAL PROPRIETARY

BOARD - P4

RTR6300
REF 200-259

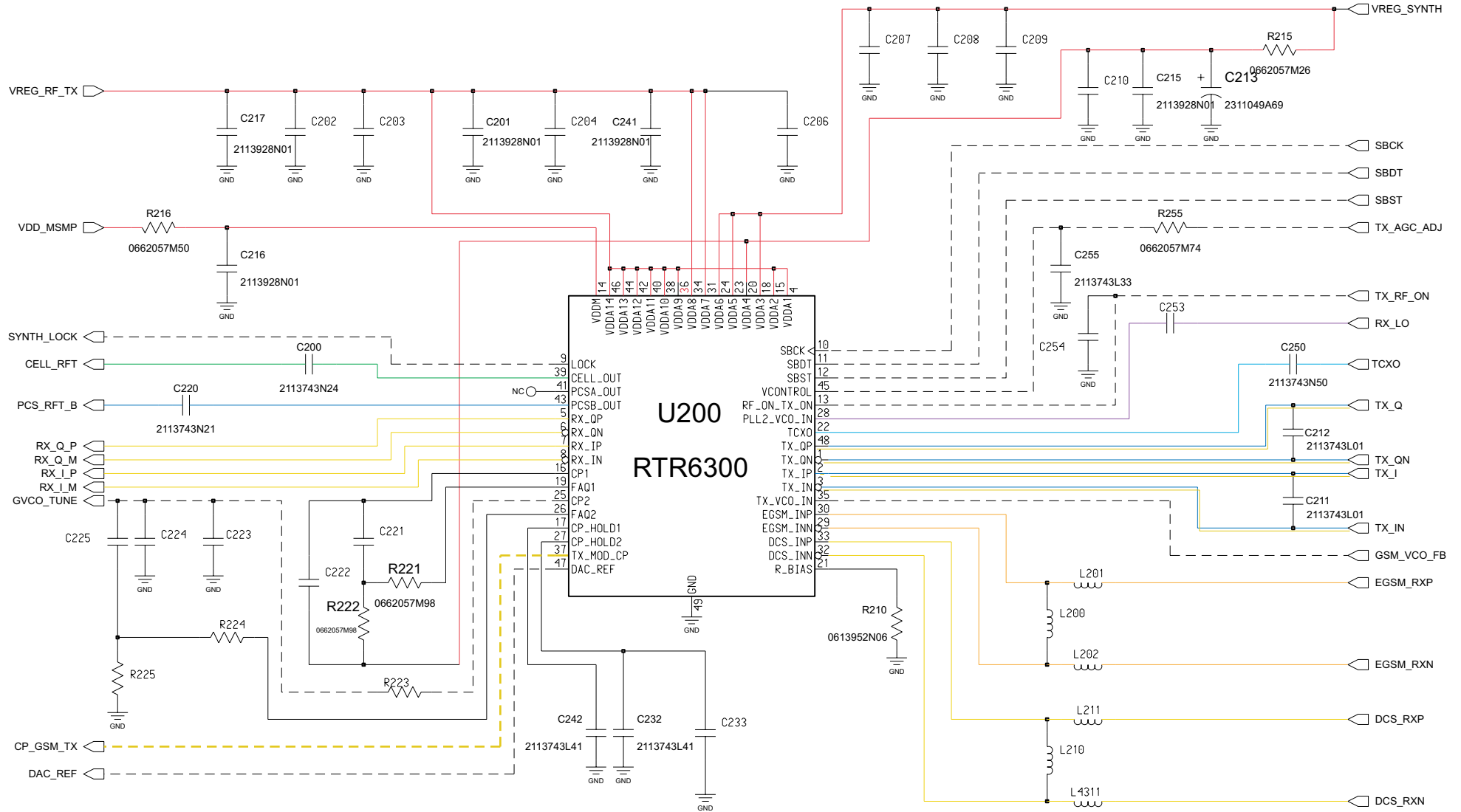

This document is propriety of MOTOROLA and it should be return if not used .
Distribution and copies of this document are not allowed with out MOTOROLA approval.

MOTOROLA CONFIDENTIAL PROPRIETARY

BOARD - P4

TX_GSM & CDMA Circuit

A840 / A860

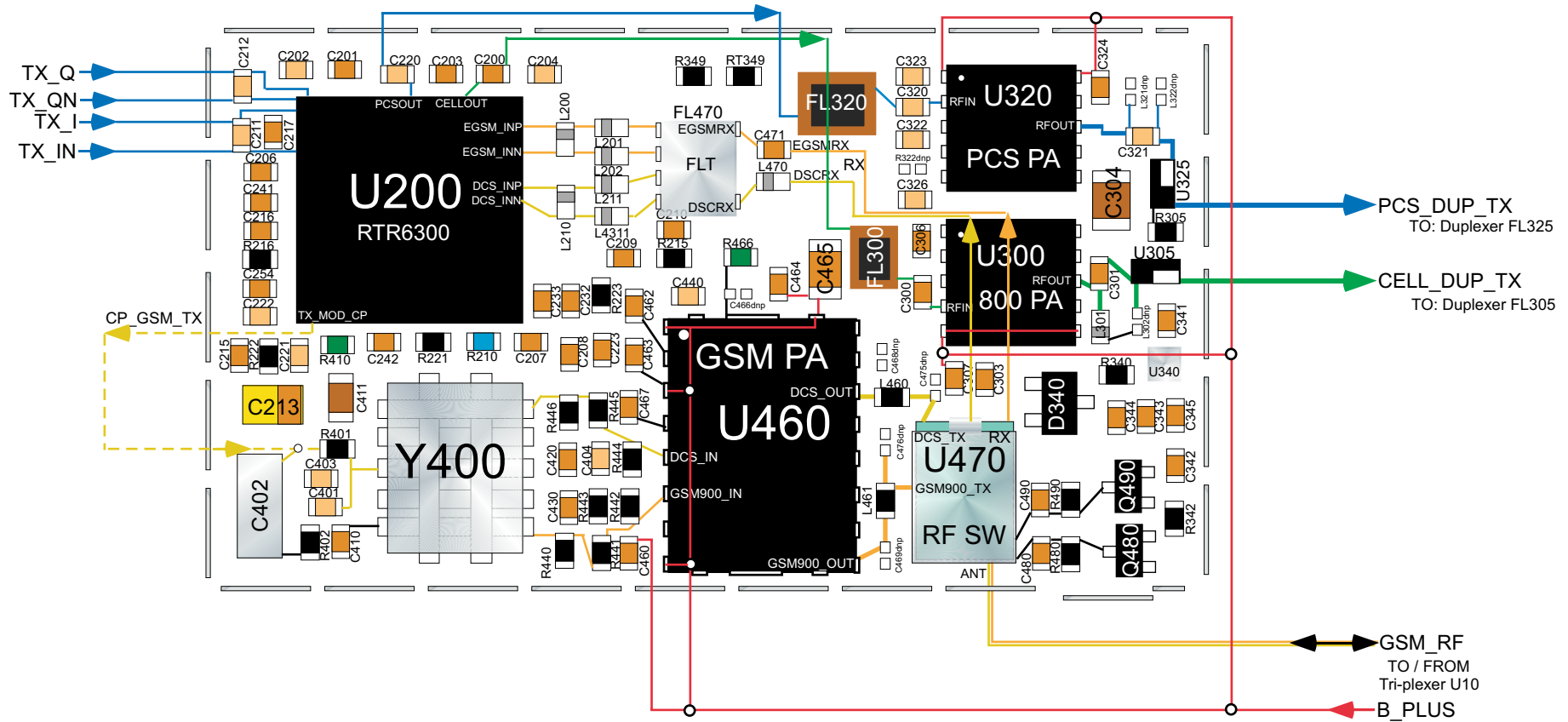
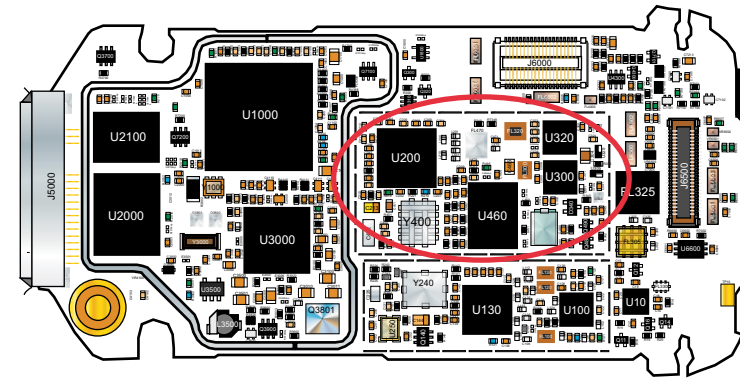

This document is property of MOTOROLA and it should be return if not used .
Distribution and copies of this document are not allowed with out MOTOROLA approval.

MOTOROLA CONFIDENTIAL PROPRIETARY

BOARD - P4

Accessory Int Schem

A840 / A860

ACCESSORY_INTERFACE

REF 5000-5999

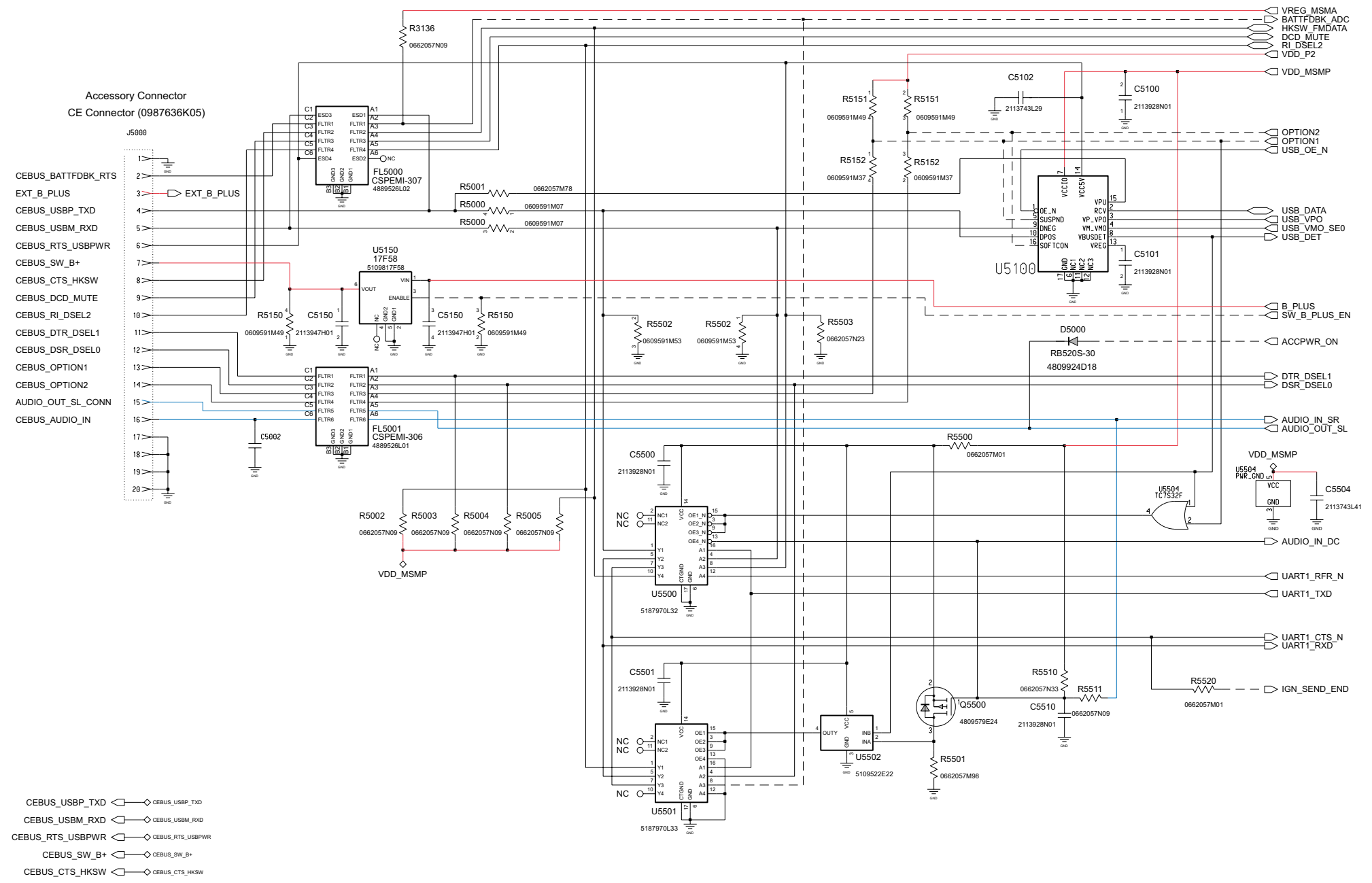

This document is property of MOTOROLA and it should be return if not used .
Distribution and copies of this document are not allowed with out MOTOROLA approval.

MOTOROLA CONFIDENTIAL PROPRIETARY

BOARD - P4

POWER_MANAGEMENT REF 3000-3999

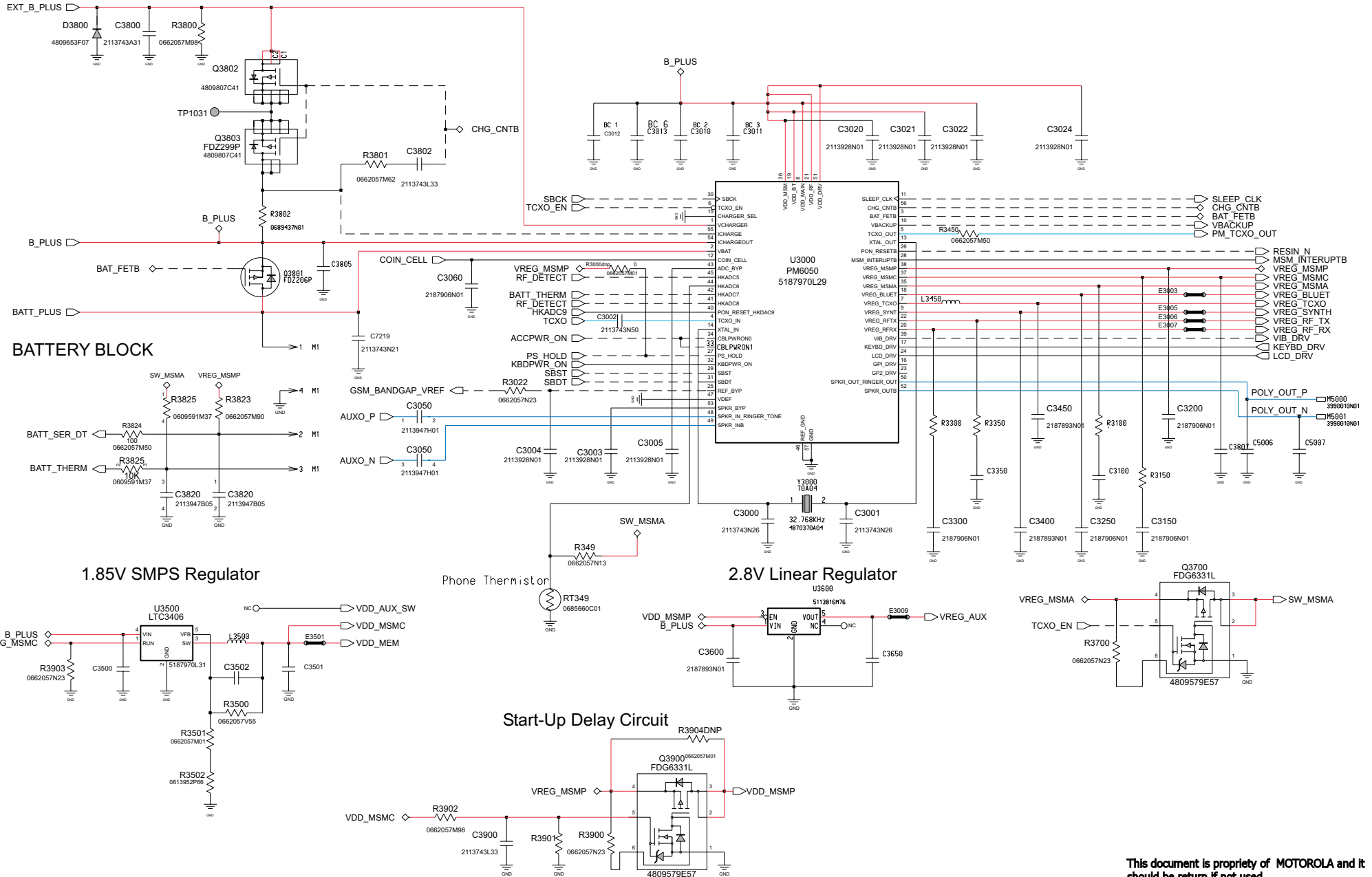

This document is property of MOTOROLA and it should be return if not used. Distribution and copies of this document are not allowed with out MOTOROLA approval.

MOTOROLA CONFIDENTIAL PROPRIETARY

BOARD - P4

PM / Charger Circuit

A840 / A860

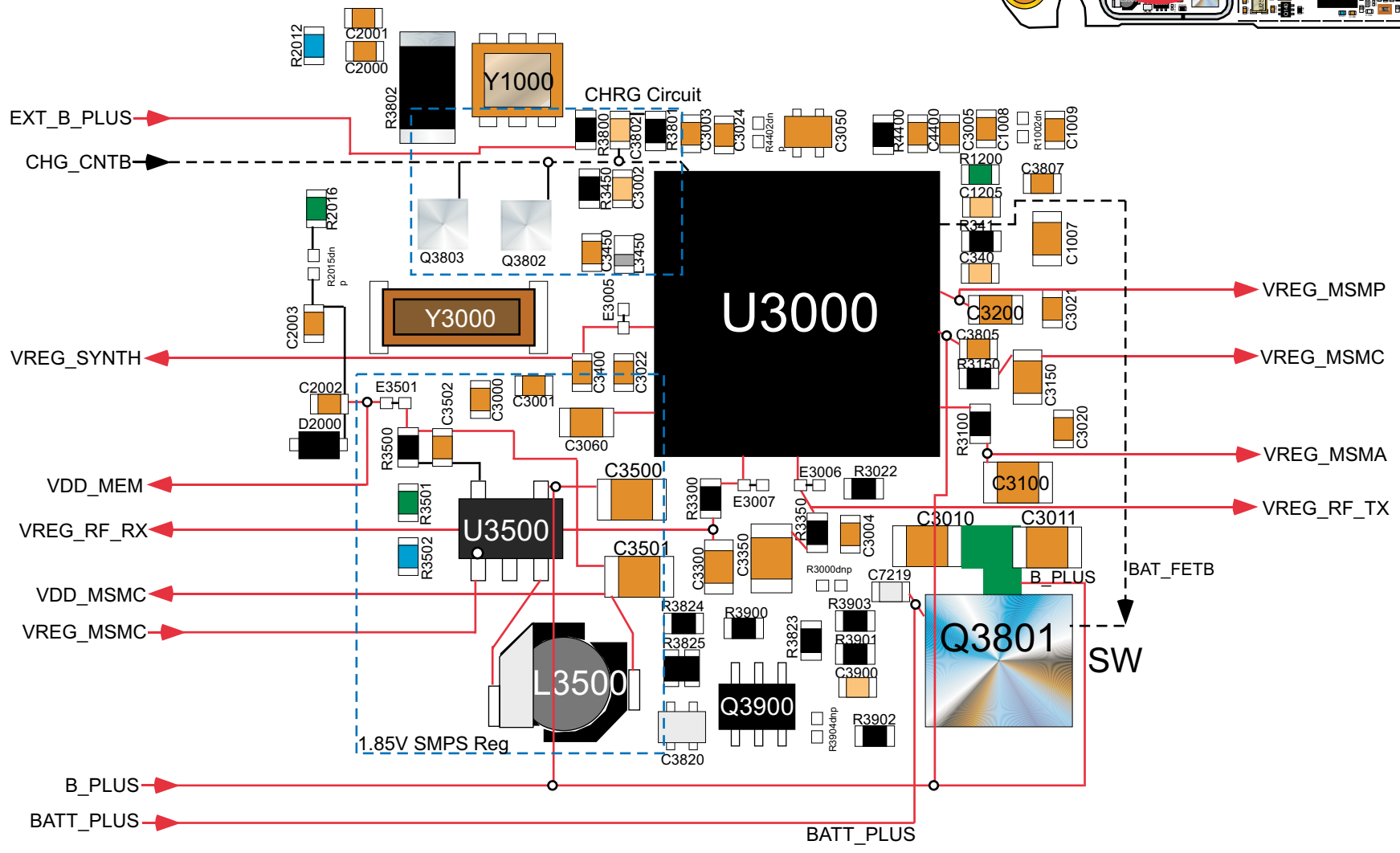
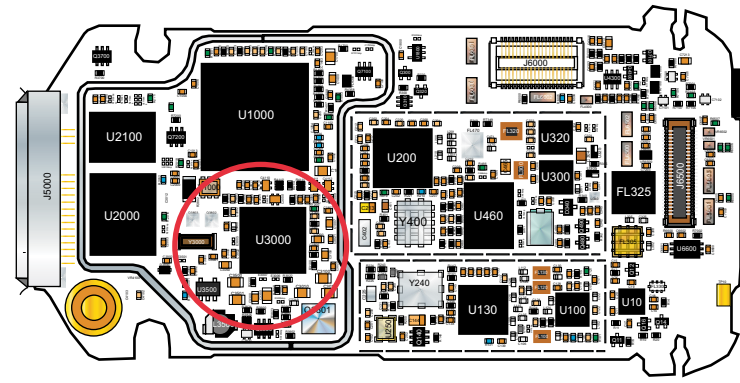

This document is property of MOTOROLA and it should be return if not used .
Distribution and copies of this document are not allowed with out MOTOROLA approval.

MOTOROLA CONFIDENTIAL PROPRIETARY

BOARD - P4

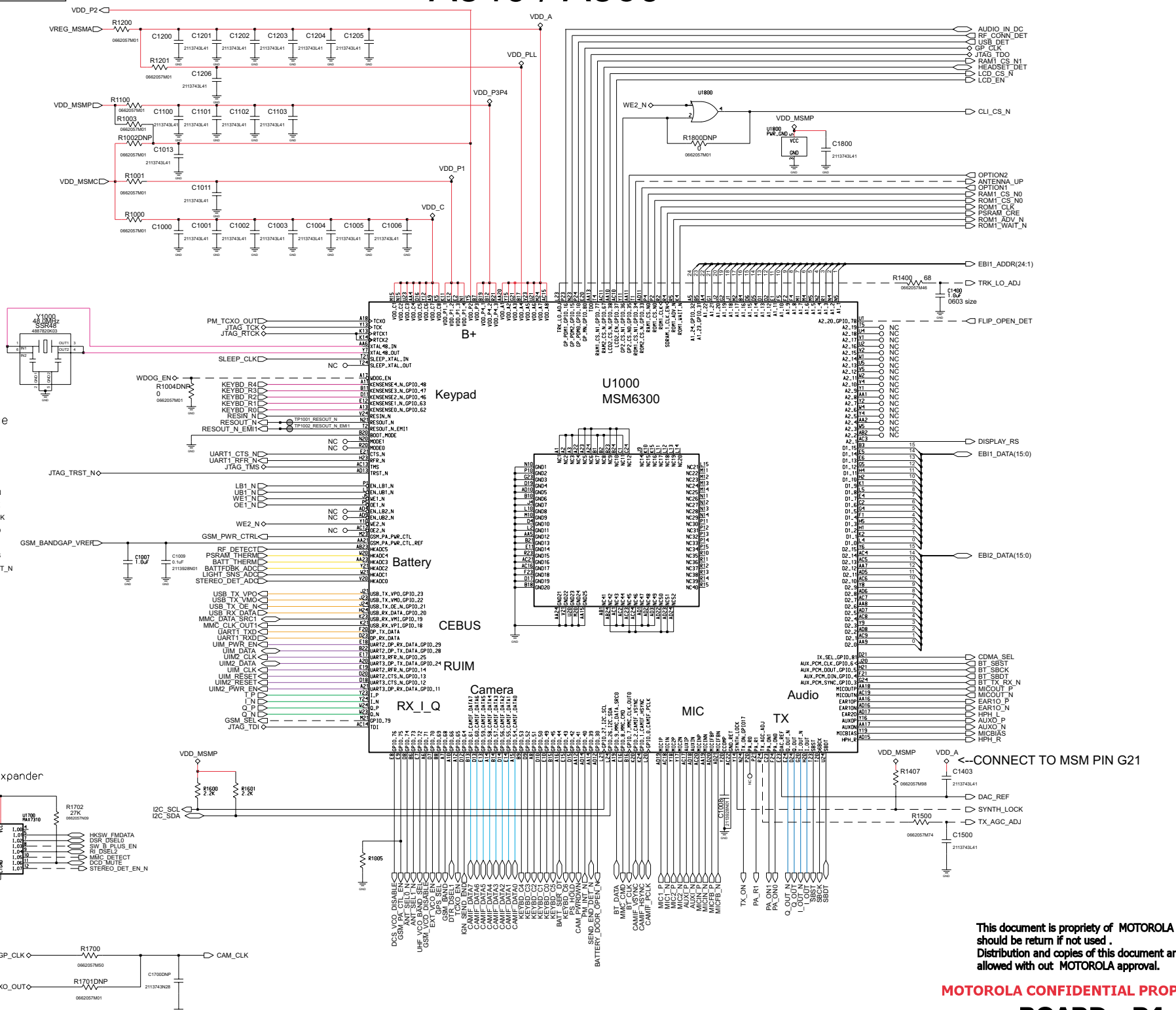

This document is propriety of MOTOROLA and it should be return if not used . Distribution and copies of this document are not allowed with out MOTOROLA approval.

MOTOROLA CONFIDENTIAL PROPRIETARY

BOARD - P4

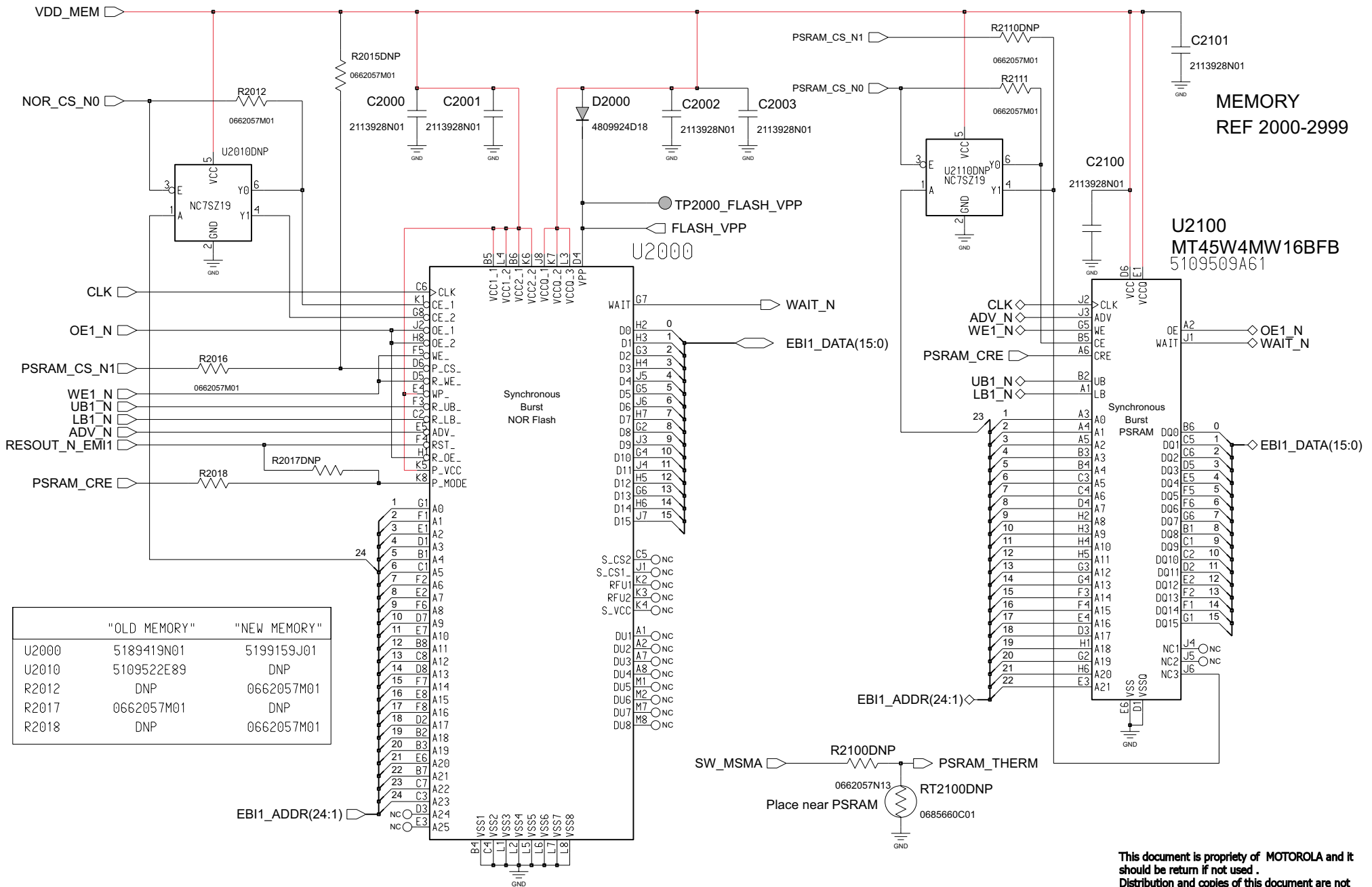

This document is propriety of MOTOROLA and it should be return if not used. Distribution and copies of this document are not allowed with out MOTOROLA approval.

MSM / Memory Circuit

A840 / A860

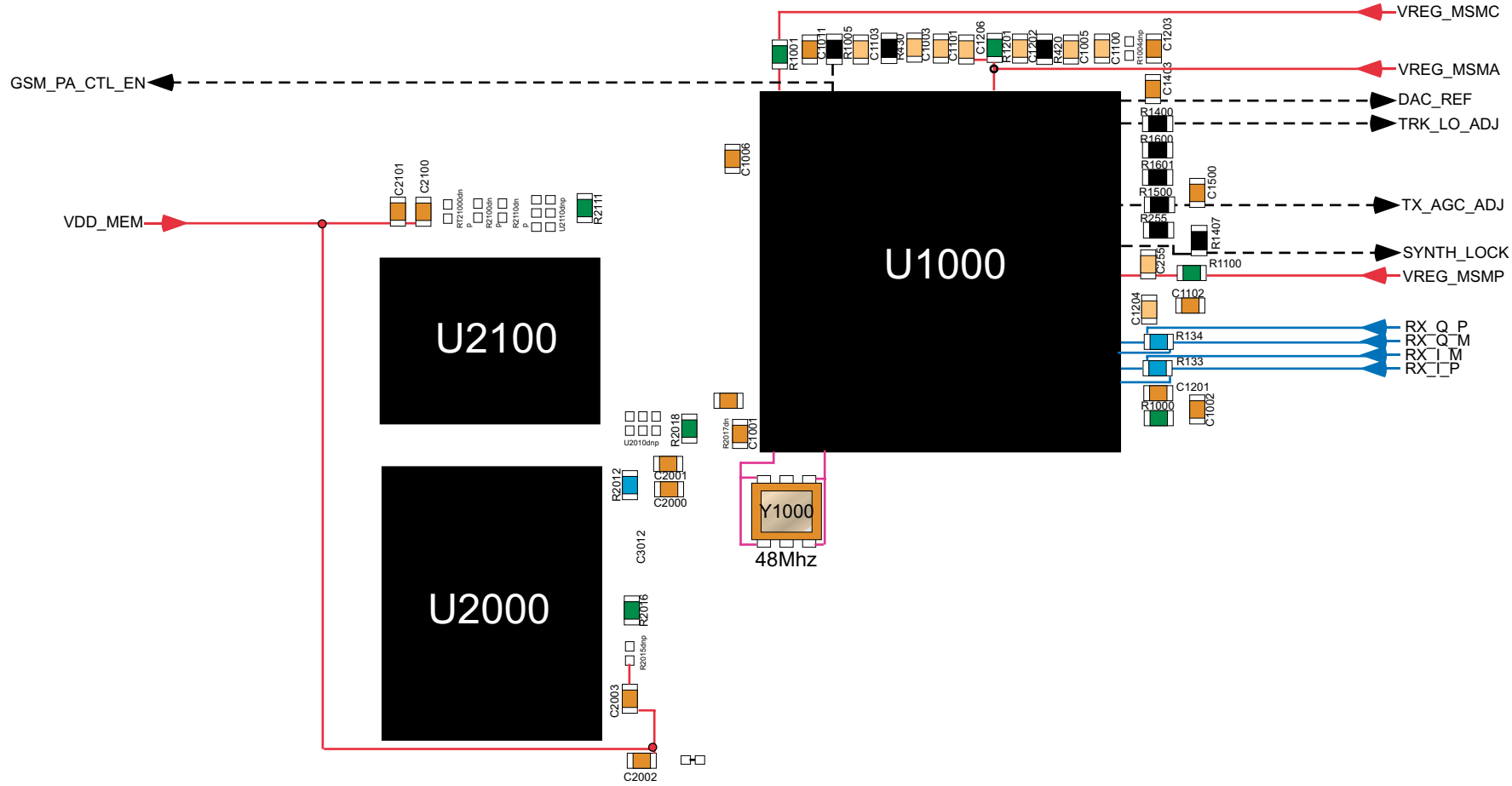
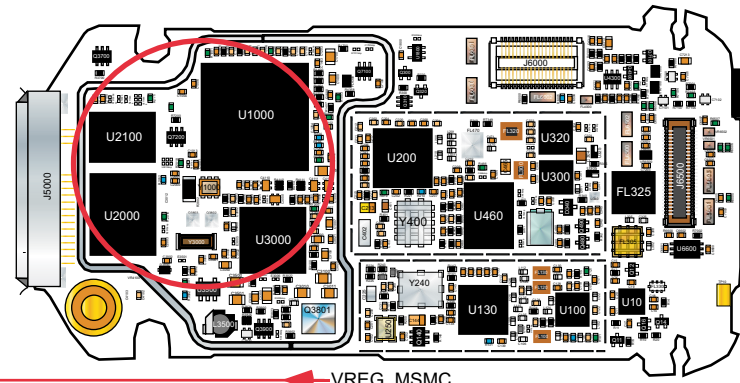

This document is propriety of MOTOROLA and it should be return if not used .
Distribution and copies of this document are not allowed with out MOTOROLA approval.

MOTOROLA CONFIDENTIAL PROPRIETARY

BOARD - P4

RUIM Schem

A840 / A860

RUIM
REF 7100-7109, 7200-7209

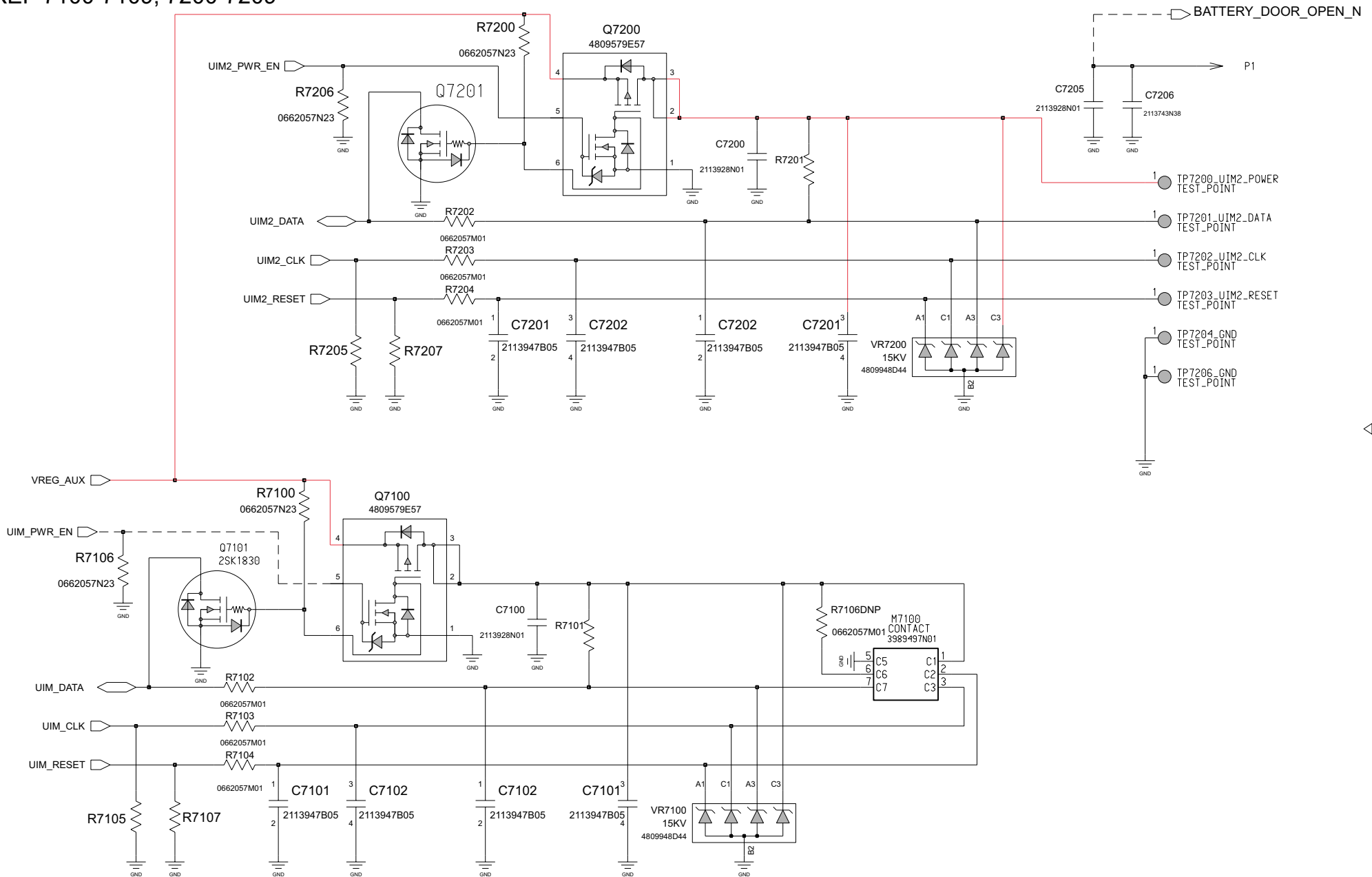

This document is property of MOTOROLA and it should be return if not used.
Distribution and copies of this document are not allowed with out MOTOROLA approval.

MOTOROLA CONFIDENTIAL PROPRIETARY

BOARD - P4

MMC
REF 7000-7009

MMC/SD CARD

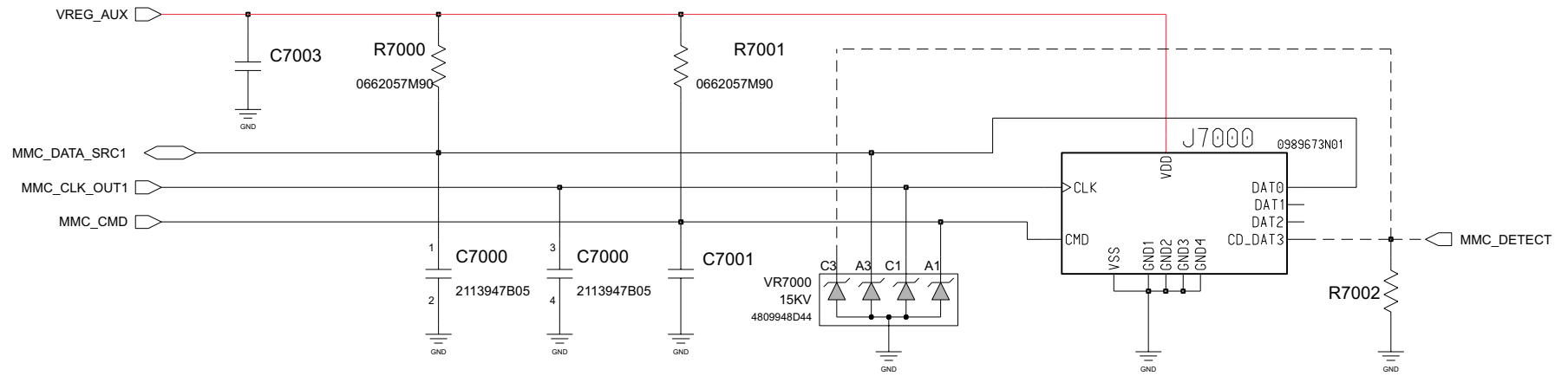

This document is propriety of MOTOROLA and it should be return if not used .
Distribution and copies of this document are not allowed with out MOTOROLA approval.

MOTOROLA CONFIDENTIAL PROPRIETARY

BOARD - P4

User Int Schem

A840 / A860

USER INTERFACE
REF 6000-6999

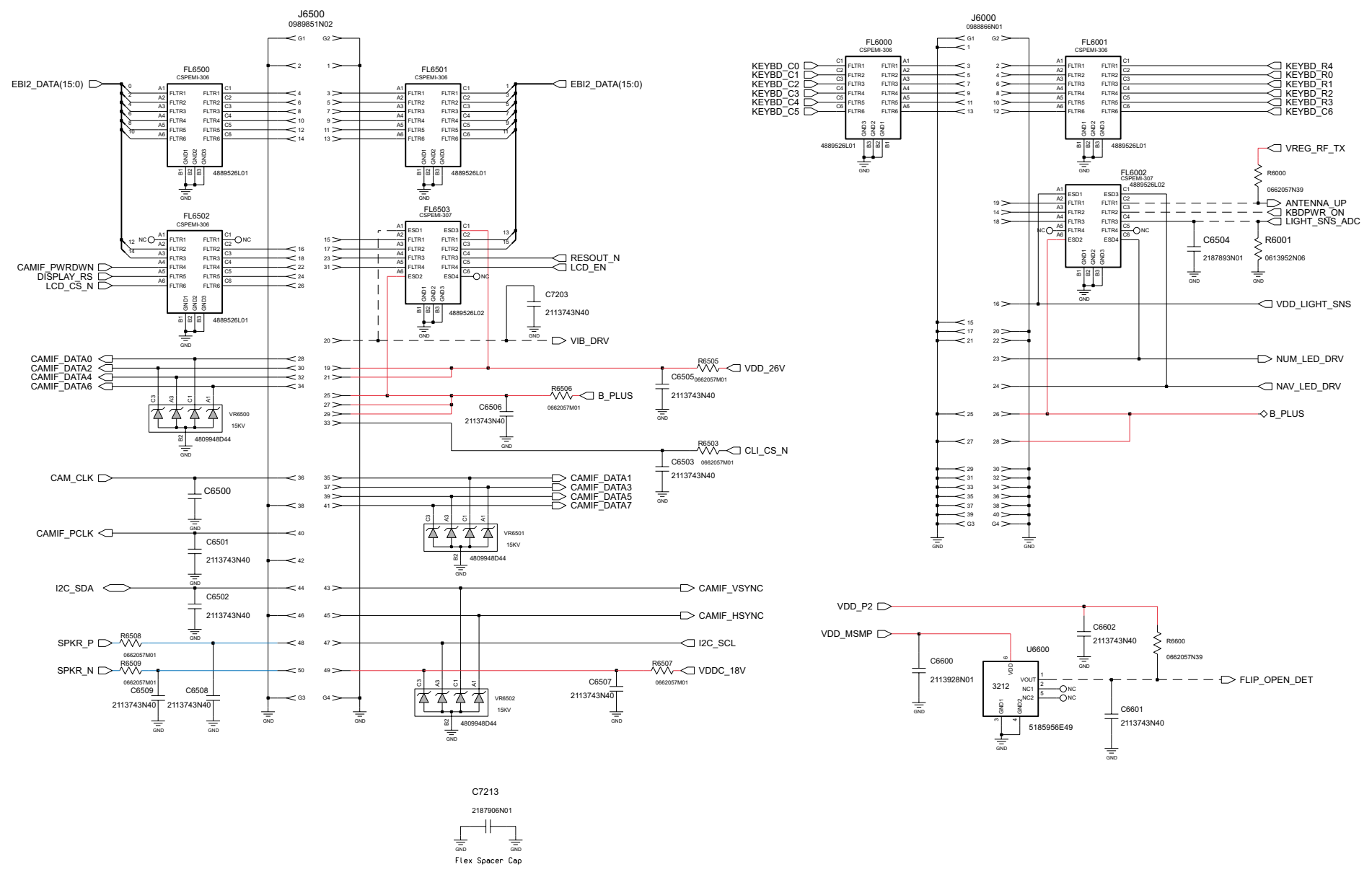

This document is propriety of MOTOROLA and it should be return if not used .
Distribution and copies of this document are not allowed with out MOTOROLA approval.

MOTOROLA CONFIDENTIAL PROPRIETARY

BOARD - P4

AUDIO INTERFACE

REF 4000-4499

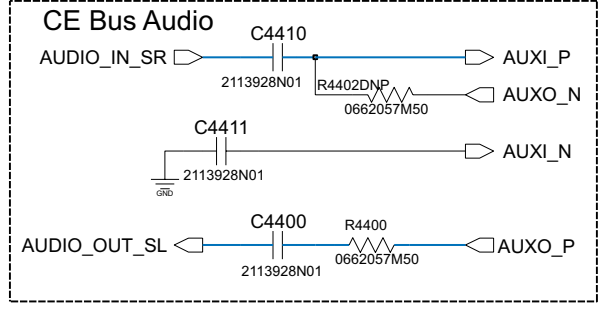
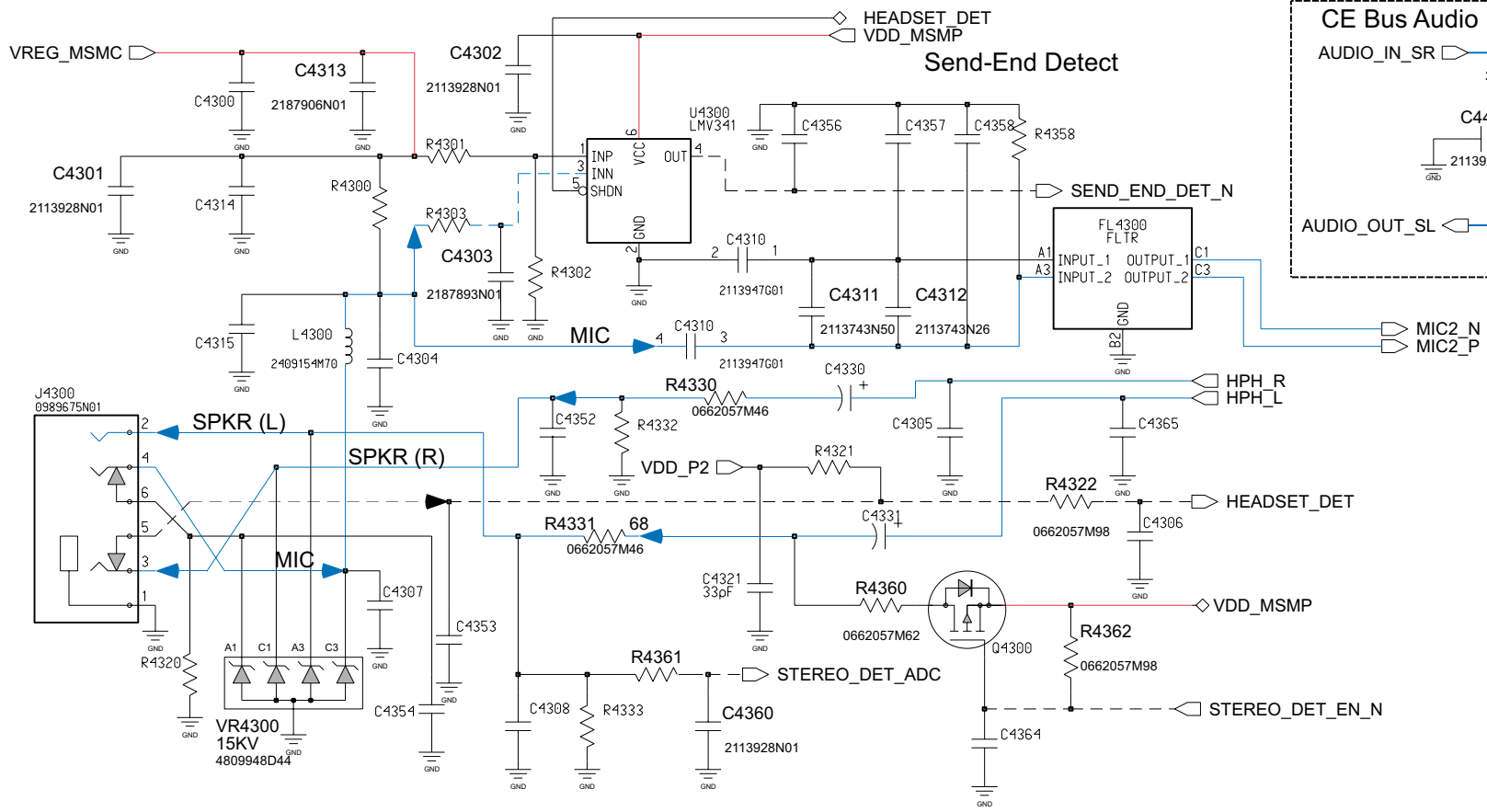
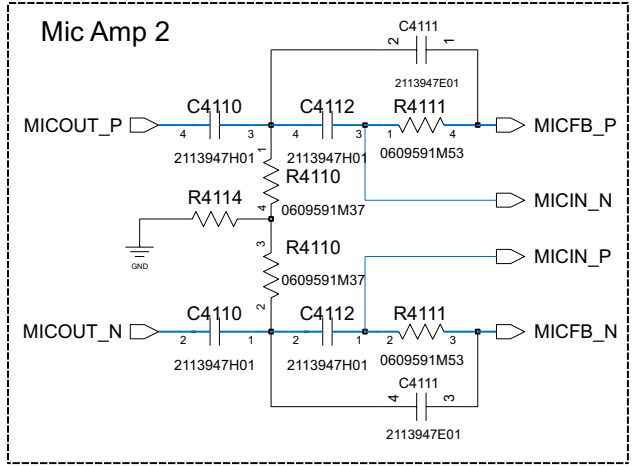
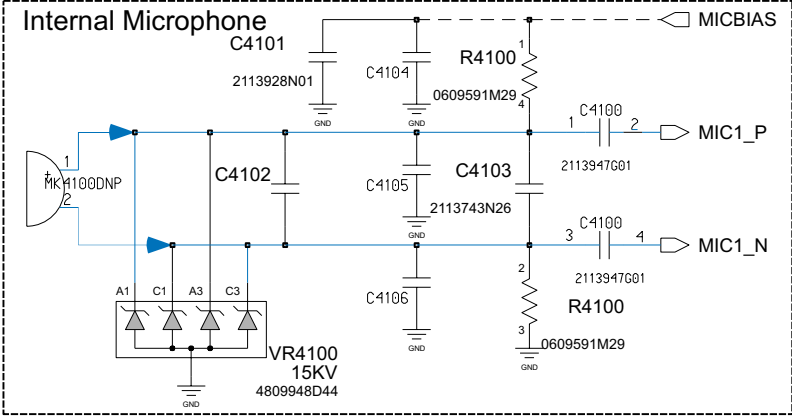
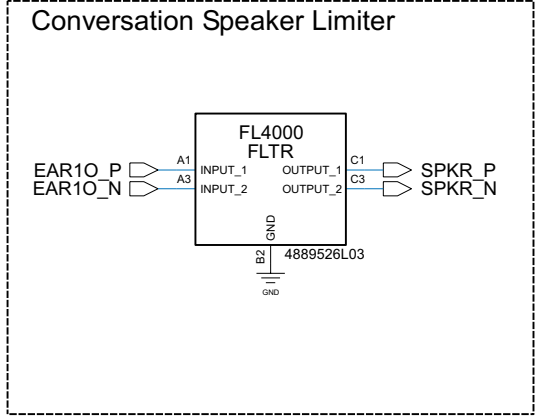

This document is propriety of MOTOROLA and it should be return if not used .
Distribution and copies of this document are not allowed with out MOTOROLA approval.

MOTOROLA CONFIDENTIAL PROPRIETARY

BOARD - P4

Audio Circuit

A840 / A860

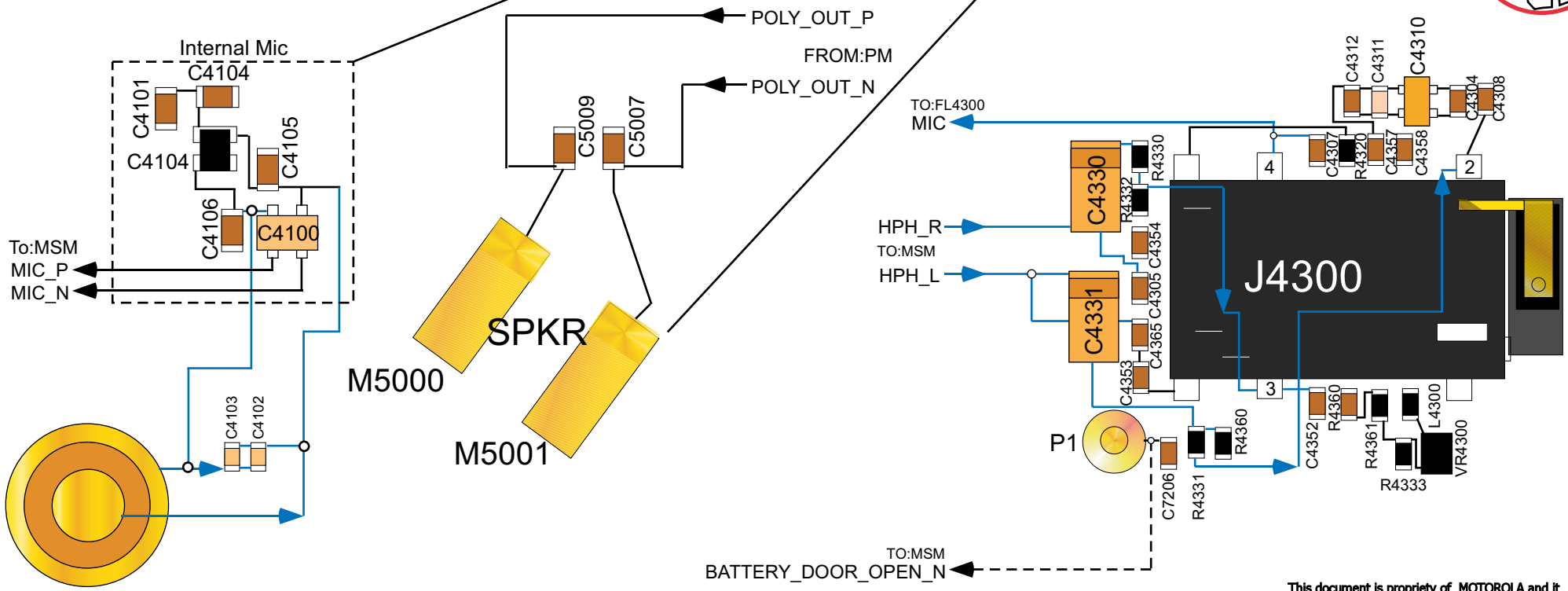
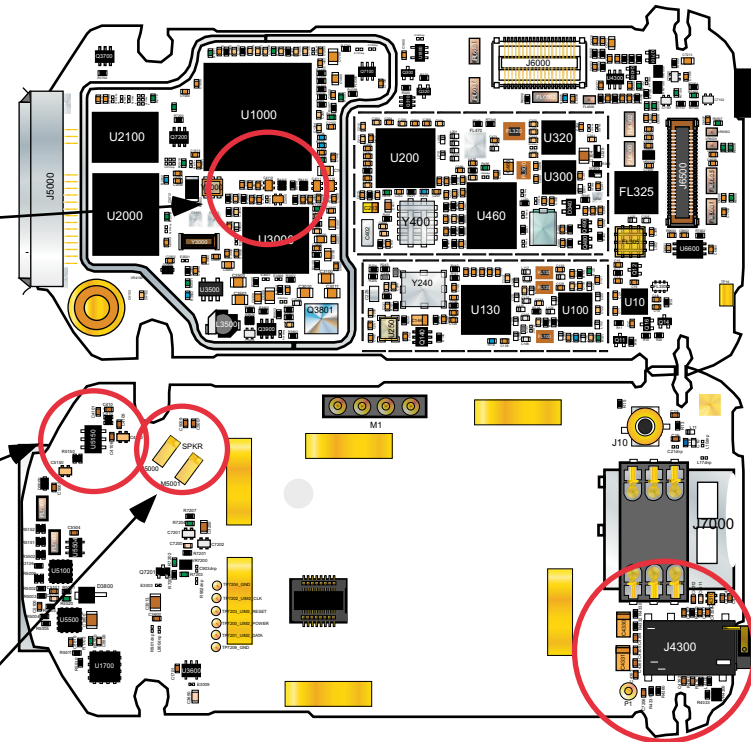
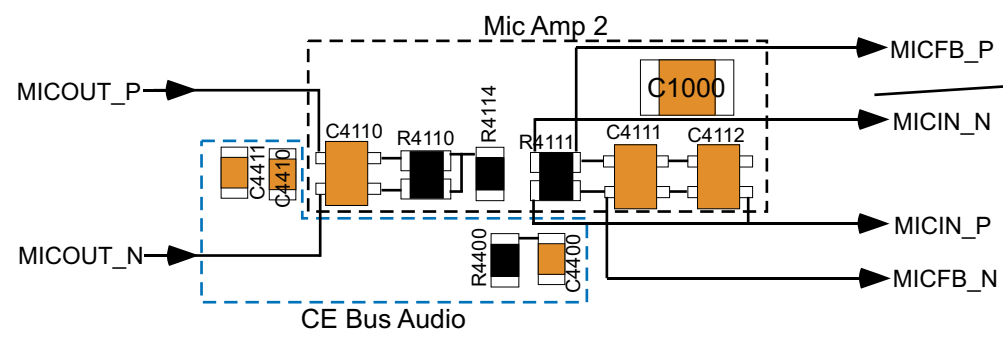

This document is property of MOTOROLA and it should be return if not used .
Distribution and copies of this document are not allowed with out MOTOROLA approval.

MOTOROLA CONFIDENTIAL PROPRIETARY

BOARD - P4

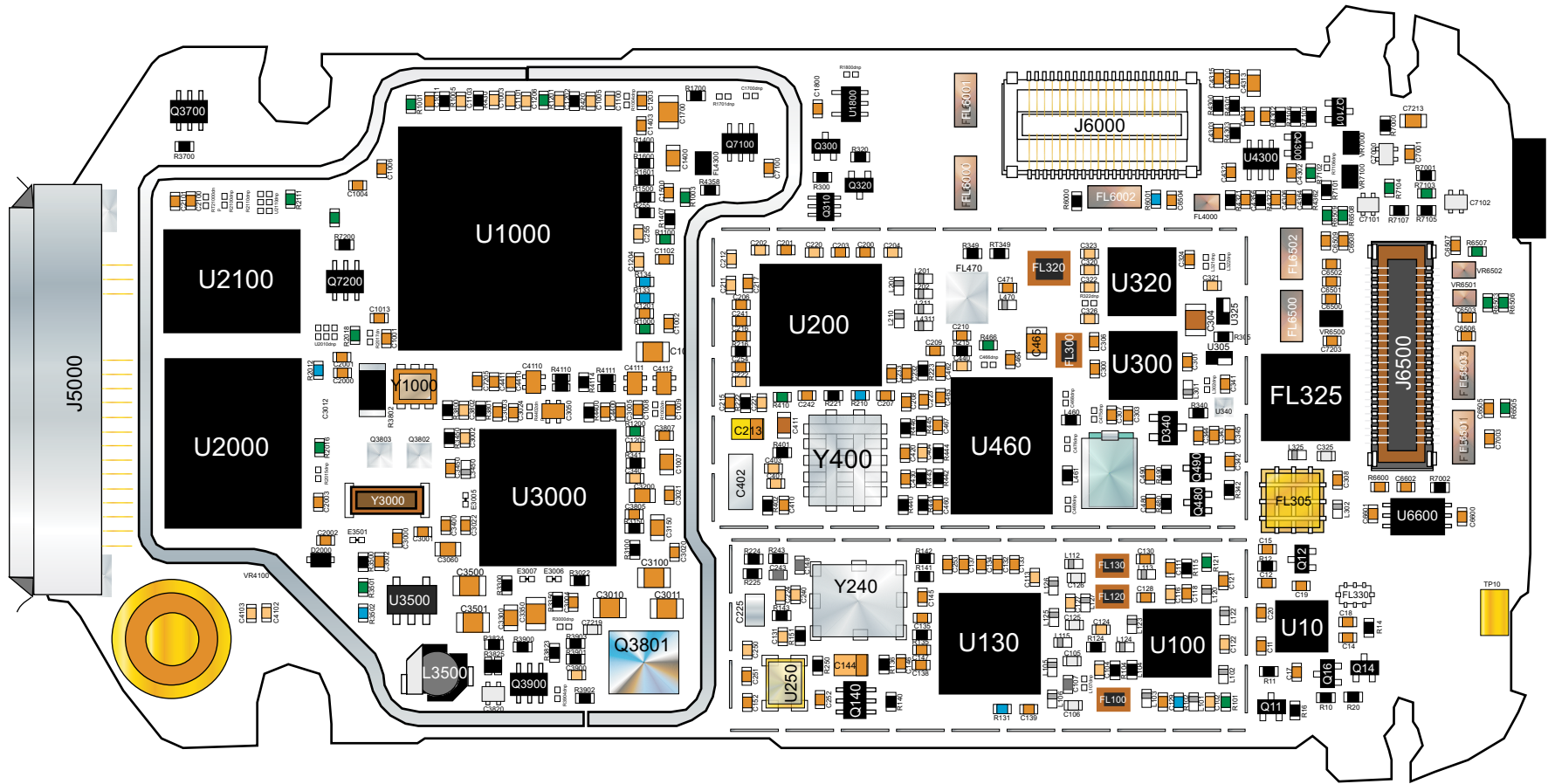

This document is property of MOTOROLA and it should be return if not used .
Distribution and copies of this document are not allowed with out MOTOROLA approval.

MOTOROLA CONFIDENTIAL PROPRIETARY

BOARD - P4

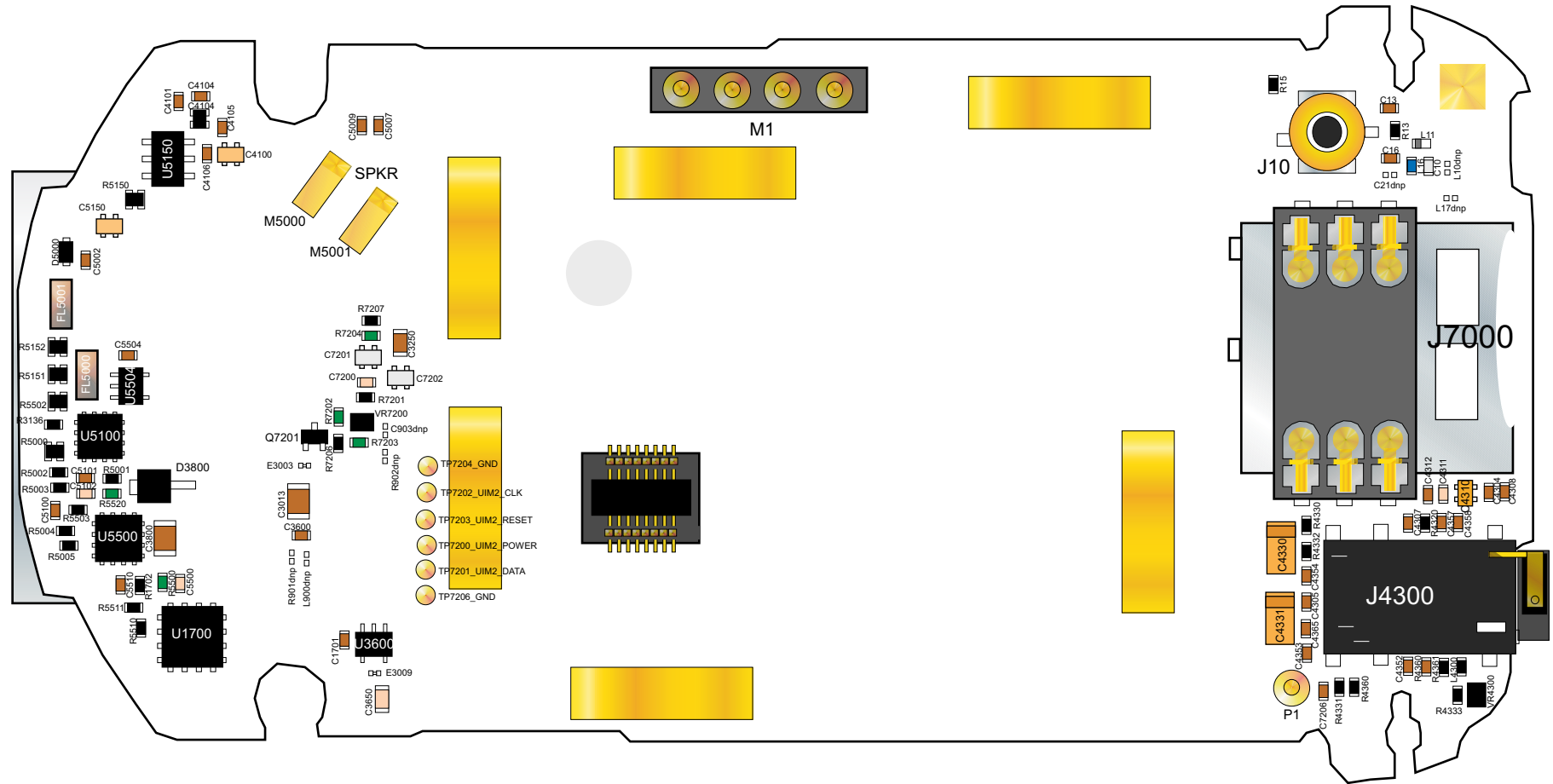

This document is property of MOTOROLA and it should be return if not used .
Distribution and copies of this document are not allowed with out MOTOROLA approval.

MOTOROLA CONFIDENTIAL PROPRIETARY

BOARD - P4

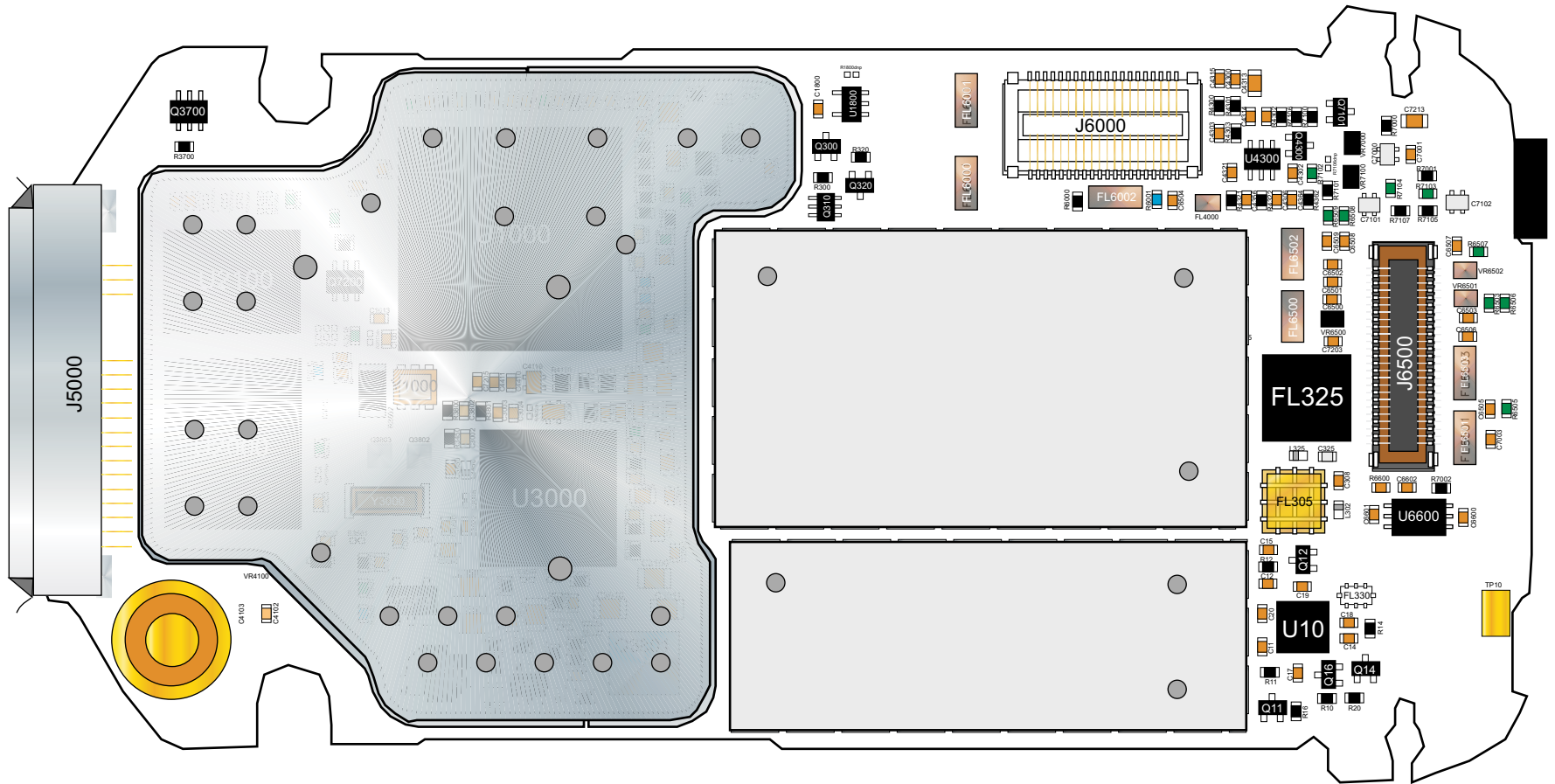

This document is property of MOTOROLA and it should be return if not used .
Distribution and copies of this document are not allowed with out MOTOROLA approval.

MOTOROLA CONFIDENTIAL PROPRIETARY

BOARD - P4

W/CDMA SUG3974AB		CDMA & GSM Mechanical	A840 / A860
Part Number	Description	Reference Designators	
SHN8527B	ASSY,HSG,HDW,A860	-	
0187521Y02	ASSY,KYBD,,V710	-	
0789329N03	SPRT,STIFNR,SS,KYBD V710	-	
1187528Y02	ADHES,,MIC V710	-	
3289444N01	GSKT,,MIC,PORON,,4.6MMLG,,1.63MMTHK,V700	-	
3889327N01	KEY,SIDE,PLASTIC - ABS,VR/CAMR ASSY PCC V700	-	
3889364N01	KEY,SIDE,PLASTIC - ABS,VOL ASSY PCC V700	-	
4088397N01	SW,METAL DOME,29,SPST,,,,4MA,24V,,MYL V700	-	
7587383Y01	PAD,CNDT	-	
8489448N01	FLX,KYPD,,V700	-	
0189699N07	ASSY,FLIP,,A860	-	
0387791L01	SCR,METRIC,,STAR,BTN,STL,ZINC PLATED/CHROMATE-YELLOW,BTN HD XCV	-	
0389469N02	SCR,,M1.6X.35,4.25MM,STAR,HEX,STL,,METRIC	-	
0589944N02	GROM,,TPR,RF, WORLD PHN	-	
0787536Y01	BRACKET ASSEMBLY,,PC,ENDO A840/A860	-	
0790162N03	BRACKET ASSEMBLY,,ENDO WRLD PHN FROSTED	-	
1589388N01	TUBE,ANT,PLAS,GUIDE, V700 CDMA	-	
3287537Y01	GSKT,,PORON,,37.95MMLG,15.9MMWID,.63MMTHK,SP KR A840	-	
3287540Y01	GSKT,,,,,,,,,ENDO TO SPKR CVR	-	
3289975N01	GSKT,,SEAL,,,,,,18MM POLY SPKR	-	
3989913N01	CONT,,NONE,1CONT,,ANT V710	-	
4289945N01	CLP,BAT,SS,,,,,RETNG V700C	-	
5089855N01	SPKR,,600-7000,8OHM,1W,,POLY 18MM	-	
7587391Y01	PAD,,SPCR 18MM POLY SPKR	-	
1589318N03	HSG,CVR,PLASTIC - POLYCARBONATE,SPKR FRST SLV	-	
1589331N02	HOUSING ASSEMBLY,FRNT,PLASTIC - POLYCARBONATE,BZL A840 WRDPH	-	
1589876N04	HSG,,PLASTIC - POLYCARBONATE,KYPD BZL GALAXY GRAY	-	
7589801N01	BMPR,,SILRUB,FLIP	-	
3889338N04	KYPD,,PLASTIC - POLYCARBONATE,WORLD PHN A860 - STROKE	-	
3987491Y01	CONN,POGO,M,6CONT,,,,,A840 SIM DETECT	-	
5089405N01	MIC,,200-3400,,OMNI-DIRECTIONAL,-41MV/DB,2,,MIC PCC V700	-	
8587488Y01	ANT,RET,824MHZMIN,1.99GHZMAX,,W/ TELESCOPIC BOT STOP	-	
SLG4437AD	ASSY,PCB,MN,,WCDMA,A840	-	

W/CDMA SUG3974AB	CDMA & GSM Electrical	A840 / A860
Part Number	Description	Reference Designators
0609591M37	RES CHIP DUAL 10K 5% 0.63W	R4110, R3825
0609591M53	RES CHIP DUAL 220K 5% .63W	R4111
0613952M74	RES,MO,5760OHM,1,,.0625W,SMD,0402,1005,200PPM	R102, R133, R134
0613952N06	RES,MO,11300OHM,1,,.0625W,SMD,0402,1005,200PPM	R131, R210, R6001
0613952P66	RES,MO,475000OHM,1,,.0625W,SMD,0402,1005,200PPM	R3502
0662057M01	RES. CHIP 0 5% 20X40	R6506, R6505, R6508, R6507, R121, R1201, R1200, R6503, R1100, R2018, R2111, R1000, R7104, R7103, R7102, R2012, R101, R6509, R1001, R2016, R1003, R410, R466, R3501
0662057M02	RES. CHIP 1.0 5% 20X40	R3350, R3300, R3100, R3150
0662057M26	RES. CHIP 10 5% 20X40	R136, R215, R342
0662057M30	RES. CHIP 15 5% 20X40	R441, R445
0662057M34	RES. CHIP 22 5% 20X40	R124, R104
0662057M38	RES. CHIP 33 5% 20X40	R142, R141, R223
0662057M42	RES. CHIP 47 5% 20X40	R402, R443
0662057M43	RES. CHIP 51 5% 20X40	R151, R305
0662057M46	RES. CHIP 68 5% 20X40	R1400
0662057M48	RES. CHIP 82 5% 20X40	R401
0662057M50	RES. CHIP 100 5% 20X40	R216, R250, R3824, R1700, R4400, R3450, R430, R115, R420, R135
0662057M58	RES. CHIP 220 5% 20X40	R442
0662057M59	RES. CHIP 240 5% 20X40	R340
0662057M60	RES. CHIP 270 5% 20X40	R440, R446
0662057M62	RES. CHIP 330 5% 20X40	R3801
0662057M74	RES. CHIP 1000 5% 20X40	R341, R255, R1500, R243, R444
0662057M82	RES. CHIP 2200 5% 20X40	R4300, R1601, R1600
0662057M84	RES. CHIP 2700 5% 20X40	R224
0662057M88	RES. CHIP 3900 5% 20X40	R143, R7105, R7107
0662057M90	RES. CHIP 4700 5% 20X40	R3823, R7001, R7000
0662057M91	RES. CHIP 5100 5% 20X40	R225
0662057M98	RES. CHIP 10K 5% 20X40	R4322, R7101, R12, R1407, R14, R3800, R222, R221, R11, R4362, R3902
0662057N13	RES. CHIP 39K 5% 20X40	R349, R4303, R4301
0662057N15	RES. CHIP 47K 5% 20X40	R16, R140, R1005
0662057N23	RES. CHIP 100K 5% 20X40	R320, R10, R3022, R490, R480, R3900, R3903, R300, R7200, R7100, R7106, R3700
0662057N39	RES. CHIP 470K 5% 20X40	R7002, R4114, R6000, R6600, R3901, R4321
0662057N47	RES. CHIP 1.0 MEG 5% 20X40	R20, R4302, R4358
0662057V55	RES CHIP 1MEG 1%	R3500
0685660C01	THERMISTOR 3% 0402	RT349
0689437N01	RES,CHIP, .1OHM,1%,.33W,,,, THK FILM, 0.1 OHM, 1%, 0.33W (3216)	R3802
0809084T42	CAP,FILM,6800PF,,.50V-DC,,CHIP	C225
0888600M29	CAP	C402
0987636K07	CONN,RCPT,17CONT,,SM,I/O,F,,I/O 17 PINS	J5000
0988866N01	CONN,RCPT,40CONT,ST,SMD	J6000
0989851N02	CONN,RCPT,,,,,,,,,0.4MM PITCH, 1.5MM HEIGHT, 50PIN	J6500
2113743L01	CAP CHIP 220 PF 10% X7R	C212, C211, C240
2113743L09	CAP CHIP 470 PF 10% X7R	C222
2113743L13	CAP CHIP 680 PF 10% X7R	C224
2113743L17	CAP CHIP 1000 PF 10% X7R	C322, C204, C440, C340, C131, C403
2113743L33	CAP CHIP 4700 PF 10% X7R	C3802, C255, C3900
2113743L35	CAP CHIP 5600 PF 10% X7R	C221
2113743L41	CAP CHIP 10000 PF 10% X7R	C1101, C1403, C1204, C463, C1100, C1103, C1500, C251, C1102, C1011, C1203, C1002, C242, C1001, C1003, C1202, C1201, C1013, C1206, C1205, C1800, C232, C1005, C1006, C1004, C252
2113743N03	CAP CHIP 1.0 PF +/- .25PF COG	C128
2113743N12	CAP CHIP 2.7 PF +/- .25PF COG	C308
2113743N15	CAP CHIP 3.6 PF +/- .25PF COG	C111
2113743N18	CAP CHIP 4.7 PF +/- .25PF COG	C325
2113743N19	CAP CHIP 5.1 PF +/- .5PF COG	C125, C126
2113743N21	CAP CHIP 6.2 PF +/- .5PF COG	C7219, C106, C105, C220
2113743N24	CAP CHIP 8.2 PF +/- .5PF COG	C121, C200
2113743N26	CAP CHIP 10.0 PF 5% COG	C3000, C301, C4103, C3001
2113743N28	CAP CHIP 12.0 PF 5% COG	C202, C320, C323, C321, C326
2113743N30	CAP CHIP 15.0 PF 5% COG	C130, C20

W/CDMA SUG3974AB		CDMA & GSM Electrical	A840 / A860
Part Number	Description	Reference Designators	
2113743N34	CAP CHIP 22.0 PF 5% COG	C6500	
2113743N38	CAP CHIP 33.0 PF 5% COG	C480, C490, C4306, C3805, C146, C4356, C7001, C233, C223, C253, C133, C132, C148, C4321, C4315, C4300, C4364, C4314, C3807	
2113743N40	CAP CHIP 39.0 PF 5% COG	C207, C206, C410, C462, C7203, C460, C467, C6507, C6506, C14, C18, C6509, C6508, C6502, C6503, C15, C17, C6501, C420, C430, C7003, C203, C471, C19, C6602, C6601, C6505, C254, C300, C344, C12, C341, C343, C345, C303, C11, C210, C306	
2113743N42	CAP CHIP 47.0 PF 5% COG	C145, C137, C134, C139, C3502, C138	
2113743N50	CAP CHIP 100 PF 5% COG	C4102, C3002, C113, C250, C116, C122, C404, C124, C104, C102	
2113743N52	CAP CHIP 120 PF 5% COG	C401	
2113928A01	CAP CER CHIP 1.0 UF 10V	C1007, C1400	
2113928N01	CAP CER CHIP 0.1UF 10% 6.3	C3021, C7205, C152, C107, C217, C1009, C243, C3024, C241, C216, C3022, C4302, C324, C7100, C3005, C3004, C118, C127, C129, C201, C3020, C4301, C2000, C1008, C2002, C2003, C2001, C307, C209, C2101, C6600, C135, C2100, C147, C4400, C4410, C3003, C4411, C215, C208, C342	
2113928Z10	CAP,CERAMIC CHIP,,,,,,,,,10.0 UF 20V	C3010, C3012, C304, C1000, C3350, C1200, C3100, C3011	
2113928Z11	CAP,CERAMIC CHIP,,,,,,,,,22.0 UF 20V	C465, C3500, C3501	
2113947B05	CAP DL ARRAY 33.0PF 50V 0504	C7000, C7101, C7102, C3820	
21139470	CAP DL ARRAY 10,000PF 16V 0504	C4111	
2113947H01	CAP DL ARRAY 100,000PF 6.3V 05	C4110, C4112, C3050	
2187893N01	CAP,,1UF,,+20%,-20%,6.3V-DC,0402,-55DEG CMIN,85DEG CMAX,X5R, PK	C3450, C3400, C6504, C4303, C464	
2187906N01	CAP,CHIP,4.7UF,940000PF+/-,+20%,-20%,6.3V-DC,0603,X5R,-55DEG CMI	C3060, C7213, C3300, C3150, C3200, C4313, C411	
2311049A69	CAP TANT CHIP 10.0 UF 20% 6.3V	C213	
2311049A76	CAP TANT CHIP 2.2UF 10% 6V	C144	
2488090Y04	IDCTR,CHIP,1.8NH,5,400MA,,CER,,,,,SM,,0402,MULAY PB FREE	L470	
2488090Y05	IDCTR,CHIP,2.2NH,5,400MA,,CER,,,,,SM,,0402,MULAY PB FREE	L125, L126, L302	
2488090Y06	IDCTR,CHIP,2.7NH,5,400MA,,CER,,,,,SM,,0402,MULAY PB FREE	L325	
2488090Y08	IDCTR,CHIP,3.9NH,5,300MA,,CER,,,,,SM,,0402,MULAY PB FREE	L211, L4311	
2488090Y09	IDCTR,CHIP,4.7NH,5,300MA,,CER,,,,,SM,,0402,MULAY PB FREE	L123, L113	
2488090Y10	IDCTR,CHIP,5.6NH,5,300MA,,CER,,,,,SM,,0402,MULAY PB FREE	L112, L120	
2488090Y11	IDCTR,CHIP,6.8NH,5,300MA,,CER,,,,,SM,,0402,MULAY PB FREE	L124	
2488090Y13	IDCTR,CHIP,10NH,5,300MA,,CER,,,,,SM,,0402,MULAY PB FREE	L122, L106, L202, L105, L103, L101, L201	
2488090Y14	IDCTR,CHIP,12NH,5,300MA,,CER,,,,,SM,,0402,MULAY PB FREE	L301	
2488090Y15	IDCTR,CHIP,15NH,5,300MA,,CER,,,,,SM,,0402,MULAY PB FREE	L210	
2488090Y16	IDCTR,CHIP,18NH,5,300MA,,CER,,,,,SM,,0402,MULAY PB FREE	L127	
2488090Y18	IDCTR,CHIP,27NH,5,300MA,,CER,,,,,SM,,0402,MULAY PB FREE	L200	
2488090Y21	IDCTR,CHIP,47NH,5,200MA,,CER,,,,,SM,,0402,MULAY PB FREE	L115	
2488090Y24	IDCTR,CHIP,82NH,5,150MA,,CER,,,,,SM,,0402,MULAY PB FREE	L3450, L102	
2488158Y07	IDCTR,WW,3.3NH,,400MA,,CER,,,,,SM,,0402,+/-0.3NH PB FREE	L460	
2488158Y11	IDCTR,WW,6.8NH,5,320MA,,CER,,,,,SM,,0402,PB FREE	L461	
2488158Y20	IDCTR,WW,39NH,,150MA,,CER,,,,,SM,,0402,+/-0.3NH PB FREE	L104	
2589195N04	CHIP INDUCTOR,WW,,,,,,,,,4.7UH, POWER, 20, 4X4X1.2MM	L3500	

W/CDMA SUG3974AB	CDMA & GSM Electrical	A840 / A860
Part Number	Description	Reference Designators
2689664N01	SHIELD,,,,,,TX,WP	SH2
2689665N01	SHIELD,,,,,,RX,WP	SH3
2690141N01	SHIELD,,STL,,TIN,,,,,LOGIC, A840, REMOVABLE	SH1
4809579E02	TSTR MOSFET N-CHAN 25K1830	Q7101
4809579E24	TSTR FET P-CHAN 2SJ347 SC90	Q4300, Q14, Q300, Q320
4809579E51	FET, P-CHANNEL, 2.5V, BGA	Q3801
4809579E57	TSTR FET DUAL FDG6331L	Q3900, Q140, Q3700, Q7200, Q7100
4809606E08	DIODE DUAL SCHOTTKY RB715F	D340
4809608E03	TSTR DIG PNP DTA114YE	Q480, Q490, Q12, Q11
4809718L19	OSC,TCXO,19.2MHZ,,,,,,19.2MHZ,MOD,+/-2.0 PPM, COMP SIZE,SMD	U250
4809807C41	XSTR,DISCRETE POWER MOSFET,MOSFET,P- CH,MOSFET,,SM,,SMT,,1.7W	Q3803, Q3802
4809924D18	DIODE,SHTK,EMD2SC79,,,,,30UA,30V,,.06W,SEMICONDC TOR,1,HI SPEED SW	D2000
4809939C37	TSTR DUAL NPN DIGITAL EMT6	Q310
4809948D44	4 CHANNEL ESD ARRAY 5-PIN CHIP	VR6501, VR7100, VR7000, VR6502, VR6500, VR4100
4870370A04	REFLOWABLE CRYSTAL,32.768KHZ,	Y3000
4880048M03	TRST NPN DIG 47K/47K	Q16
4887820K03	RESON,NON-QUARTZ,48MHZ,+/-500,THIRD OVERTONE,- 20DEG CMIN	Y1000
4888481N04	OSC,VOLTAGE CONTROLLED,1.75GHZMAX,1.41GHZMIN,,,,,,RX DUALBAND	Y240
4888481N05	OSC,VOLTAGE CONTROLLED,1.75GHZMAX,897MHZMIN,,,,,,MOD TX DUALBA	Y400
4889526L01	IPD ESD FLTR 6CH 3X1.3MM 15CSP	FL6502, FL6000, FL6001, FL6500, FL6501
4889526L02	IPD ESD FLTR 4CH 3X1.3MM 15CSP	FL6503, FL6002
4889526L03	FLTR,EMI FILTER,HP,1.45GHZMAX,800MHZMIN,1.9GHZMAX,,,SM,,,2 CHANN	FL4000
4889526L04	IPD ESD FLTR 2CH 1X1.4MM 5CSP	FL4300
5109509A61	IC,SRAM,,,,,,BURST64M 54BALL FBGA	U2100
5109522E14	IC 2-INPUT OR GATE TC7S32FU	U1800
5109572E41	IC,SW,,,,,,RF , 0.6 W CDMA/AMPSP3T 3X3MM, MLP-12	U10
5109731C39	IC,OP AMP,,,,,1MHZBW,,,SC70,,,SNGL W/ SHUTDOWN	U4300
5109908K83	AMP MDL,RF,27DB,824MHZMIN,849MHZMAX,,,,,5.2V,50OHM,1. 2A,,CDMA/AM	U300
5109908K84	AMP MDL,RF,27DB,1.85GHZMIN,1.91GHZMAX,,,,,5.2V,50OHM,,, CDMA USPC	U320
5109908K92	IC,RF PWR AMP,,SKY77326,SM,,,,,,DUALBAND GSM 897/1747MHZ 6X8MM	U460
5109944C56	IC,CONV,,,,,,RFL6000	U100
5109944C57	IC,CONV,,,,,,RFR6000	U130
5109944C60	IC,,RF TRANSCEIVER,,,,,RTR6300	U200
5109962C32	IC,MDM,,MOBILE STA,MSM6300,SM	U1000
5185956E49	SW,HALL EFFECT,IC HALL EFFECT SENSOR A3212	U6600
5187970L29	IC,POWER MANAGEMENT,,,,,,PM6050	U3000
5187970L31	IC,SWG,,,SOT-23/5,,,,,600MA SYNC BUCK DC-DC	U3500
5187970L45	IC,,,,,,GSM SWITCHPLEXER	U470
5187970L46	IC,,,,,,PWR DET 2X2 MM UCSP SMD	U340
5199159J01	IC,FLSH,PSRAM STACK,256MBIT,,84NS,BGA,,,CSP T & R PARTS PB FREE	U2000
5887538N01	CPLR,,,,,,SPT (800 & 1900)	U325
5887699Y01	CPLR,DIRECTIONAL,,,,,800 & 1800MHZ 0603 SMD	U305
9103913K21	PASSIVE FILTER,SAW,BANDPASS,836MHZNOM,,,,,SM,,BP 3X3MM	FL300
9103913K23	FLTR,SAW,,,,,,BANDPASS, 881MHZ, 50OHMS, SE/100OHMS BAL, SMD	FL100
9109170T08	FLTR,SAW,BANDPASS,881.5MHZNOM,,,,,DPLX 836/881MHZ 3.8X3.8X1.5MM	FL305
9109239M31	FLTR,SAW,,1.8GHZNOM,,,SM,,1880MHZ, 3.0X3.0MM	FL320
9109239M34	FLTR,SAW,,,,,,BANDPASS, 1960MHZ, 50OHMS, SE/100OHMS BAL, , SMD	FL120

W/CDMA SUG3974AB	CDMA & GSM Electrical	A840 / A860
Part Number	Description	Reference Designators
9109474K02	FLTR,SAW,,,,,SM	FL470
9185906G09	FLTR CER DIPLX 859/1230 2012	FL330
9188203L03	FLTR,SAW,,1.88GHZNOM,,,,SM,,FBAR, 1960MHZ X1.4MM	FL325
9189312N01	FLTR,SAW,BANDPASS,1.47542GHZNOM,,,,SM,,1.4X2.0, PB-FREE	FL130
0109055A05	PCB,,SIDE 2,,WORLDPHONE MN	-
0609591M07	RES CHIP DUAL 33 5% 0.63W	R5000
0609591M29	RES CHIP DUAL 2.2K 5% 0.63W	R4100
0609591M37	RES CHIP DUAL 10K 5% 0.63W	R5152
0609591M49	RES CHIP DUAL 100K 5% .63W	R5150, R5151
0609591M53	RES CHIP DUAL 220K 5% .63W	R5502
0662057M01	RES. CHIP 0 5% 20X40	R7202, R7204, R5520, R7203, R5500
0662057M46	RES. CHIP 68 5% 20X40	R4330, R4331
0662057M62	RES. CHIP 330 5% 20X40	R4360
0662057M78	RES. CHIP 1500 5% 20X40	R4332, R5001, R4333
0662057M88	RES. CHIP 3900 5% 20X40	R7207, R7205
0662057M98	RES. CHIP 10K 5% 20X40	R7201, R13, R4361, R15
0662057N09	RES. CHIP 27K 5% 20X40	R5005, R5004, R5002, R5511, R3136, R1702, R5003
0662057N13	RES. CHIP 39K 5% 20X40	R4320
0662057N23	RES. CHIP 100K 5% 20X40	R5503, R7206
0662057N33	RES. CHIP 270K 5% 20X40	R5510
0987378K01	CONN RF MOD3	J10
0987817K02	CONN,RCPT,M,16CONT,,GOLD/NICKEL,SM,,SLDR,,5MM PITCH 1.5 STACK S	JTAG
0989673N01	CONN,,8CONT,,PUSH-PUSH, TRIFLASH	J7000
0989675N02	CONN AUD,,,,SMT,STEREO,HSET JCK	J4300
2104801Z01	CAP,CHIP,,5PF,,1PF+/-,+1%,-.1%,16V-DC,0402,NP0,- 40DEG CMIN,85DE	C10
2113743A31	CAP CHIP 1.0 UF 10% X7R	C3800
2113743L29	CAP CHIP 3300 PF 10% X7R	C5102
2113743L41	CAP CHIP 10000 PF 10% X7R	C5504
2113743N26	CAP CHIP 10.0 PF 5% COG	C4312
2113743N38	CAP CHIP 33.0 PF 5% COG	C4352, C5002, C4353, C4104, C4354, C4106, C4365, C4105, C7206, C5006, C4358, C4357, C4307, C4304, C4305, C5007, C4308
2113743N40	CAP CHIP 39.0 PF 5% COG	C16, C13
2113743N50	CAP CHIP 100 PF 5% COG	C4311
2113928N01	CAP CER CHIP 0.1UF 10% 6.3	C7200, C4101, C1701, C4360, C5500, C5100, C5101, C5510
2113928Z10	CAP,CERAMIC CHIP,,,,,,10.0 UF 20V	C3013
2113946D05	CAP,CHIP,2.2UF,,+10,-10,6.3V-DC,0603,X5R	C3650
2113947B05	CAP DL ARRAY 33.0PF 50V 0504	C7202, C7201
2113947G01	CAP,NTWK,,022UF,,+20,-20,10V- DC,,SM,0405,2CAPS,,X5R,,,CER	C4310, C4100
2113947H01	CAP DL ARRAY 100,000PF 6.3V 05	C5150
2187893N01	CAP,,1UF,,+20%,-20%,6.3V-DC,0402,,-55DEG CMIN,85DEG CMAX,X5R, PK	C3600
2187906N01	CAP,CHIP,4.7UF,940000PF+/-,+20%,-20%,6.3V- DC,0603,X5R,-55DEG CMI	C3250
2313960B86	CAP,FXD,47UF,+10,-10,4V-DC,M3216-18,,-55DEG CMIN,125DEG CMAX,1	C4331, C4330
2488090Y01	IDCTR,CHIP,1NH,5,400MA,,CER,,,,,100MHZSRF,,,0402,MU LAY PB FREE	L11
2488158Y20	IDCTR,WW,39NH,,150MA,,CER,,,,,SM,,0402,+/-0.3NH PB FREE	L4300
2489711L11	IND WW 10NH 3% 1005 SMD	L16
3987495Y01	CONN,POGO,,1CONT,,SMT,,SIM A860	P1
3989345N05	CONN,POGO,M,4CONT,,,,,PIN V710 4.2-3.1	M1
3989497N01	DEVICE SOCKET,SIM CARD,6CONT,,READER, 6 CONTACT, 2.54MM PITCH	M7100
3990010N01	CONT,,,,,SPR V710 SPKR	M5000, M5001
480957900	TSTR MOSFET N-CHAN 25K1830	Q7201
4809653F07	RECT SCHTTKY 1A MBRM120ET3	D3800
4809924D18	DIODE,SHTK,EMD2SC79,,,,30UA,30V,,06W,SEMICONduc TOR,1,HI SPEED SW	D5000
4809948D44	4 CHANNEL ESD ARRAY 5-PIN CHIP	VR7200, VR4300
4889526L01	IPD ESD FLTR 6CH 3X1.3MM 15CSP	FL5001
4889526L02	IPD ESD FLTR 4CH 3X1.3MM 15CSP	FL5000

W/CDMA SUG3974AB		CDMA & GSM Electrical	A840 / A860
Part Number	Description	Reference Designators	
5109522E14	IC 2-INPUT OR GATE TC7S32FU	U5504	
5109817F58	IC CURRENT LIM SW SOT23-6	U5150	
5113816M76	IC,VREG,,,,,,,,,80MA 2.8V LOG LQ, LDO	U3600	
5187970L32	IC,BFR,4BITS,NLSF3T125,,,3ST,SM,,,QUAD ACTV LOW	U5500	
5187970L42	IC,XCVR,,,,,,,,SM,,,USB V2.0 FULL-SPEED ONLY BCC16	U5100	
5187970L47	IC,,,,,,,,8BIT I/O PORT EXPANDER,4MM X 4MM THIN QFN	U1700	
1010041C19	SOLDER PASTE(EU1355 ALLOY/PWD)	-	
8489441N04	PCB,MN,,,WORLDPHONE	-	

A

alert settings 15
antenna, removing and replacing 32

B

battery
 charge indicator 15
 function 15
 removing 31
battery cover, removing and replacing 29

C

Canadian Interference-Causing Equipment regulations 5
copyrights
 computer software 6

D

disassembly 28
display bezel
 removing 42
display module, removing and replacing 43

E

exploded view diagram 51
exploded view parts list 52

F

FCC rules 5
features
 text entry 12
Flip Assembly and Transceiver Board, removing and replacing 36
flip assembly sleeve, removing and replacing 40
flip display lens, removing and replacing 39
flip knuckle, removing and replacing 41

I

identification 47
 product 5
Introduction 5

K

keyboard stiffener, removing and replacing 35
keypad
 removing 44
keypad bezel

removing 33
keypad, removing and replacing 44

M

menu structure 15
motor/vibrator Assembly, removing and replacing 45

N

names
 product 5

O

operation 13
 alert settings 15
 battery 15
 controls, indicators, and I/O connectors 13
 icons 15
 menu navigation 14
 menu structure 15
overview, product 11

P

parts
 exploded view diagram 51
 exploded view parts list 52
product
 identification 5
 names 5
product overview 11
 features 11
publications, related 50

R

regulatory agency compliance 5
related publications 50
removing
 antenna 32
 battery 16, 31
 battery cover 29
 display bezel 42
 display module 43
 Flip Assembly and Transceiver Board 36
 flip assembly sleeve 40
 flip display lens 39
 flip knuckle 41
 keyboard stiffener 35
 keypad 44
 keypad bezel 33

- motor/vibrator 45
- speaker cover 34
- replacement parts
 - ordering 8
- replacing
 - antenna 32
 - battery 31
 - battery cover 29
 - display bezel 42
 - display module 43
 - Flip Assembly and Transceiver Board 36
 - flip assembly sleeve 40
 - flip display lens 39
 - flip knuckle 41
 - keyboard stiffener 35
 - keypad 44
 - keypad bezel 33
 - motor/vibrator assembly 45
 - speaker cover 34

S

- service manual
 - about 6
 - audience 6
 - conventions 7
 - scope 6
- service policy 7
 - customer support 7
 - out of box failure 7
 - product support 7
- shut down
 - upon battery removal 16
- SIM card
 - personality transfer 47
- speaker cover, removing and replacing 34
- specifications 9
- support
 - customer 7
 - product 7

T

- text entry 12
- tools and test equipment 27

W

- warranty service 7

MOTOROLA, the Stylized M Logo, and all other trademarks indicated as such herein are trademarks of Motorola, Inc.

® Reg. U.S. Pat. & Tm. Off.

© 2004 Motorola, Inc.

All rights reserved.

Personal Communications Sector.

600 North US Hwy 45

Libertyville IL, 60048