

Baseband

RF

BB_CLK_15_36M	BB_CLK_15_36M	BB_CLK_15_36M
TEMP_SENSE	TEMP_SENSE	TEMP_SENSE
BBIF_RX_FRM	BBIF_RX_FRAME	BBIF_RX_FRAME
BBIF_TX_FRM	BBIF_TX_FRAME	BBIF_TX_FRAME
BBIF_CLK	BBIF_CLK	BBIF_CLK
BBIF_TX(7:0)	BBIF_TX(7:0)	BBIF_TX(7:0)
BBIF_RX(7:2)	BBIF_RX(5:0)	BBIF_RX(7:2)
TX_RX_ERROR	TX_RX_ERROR	TX_RX_ERROR
HARMONY_CS	HARMONY_CS	HARMONY_CS
WB_SPI_MISO	WB_SPI_MISO	WB_SPI_MISO
WB_SPI_CLK	WB_SPI_CLK	WB_SPI_CLK
WB_SPI_MOSI	WB_SPI_MOSI	WB_SPI_MOSI
RF_RESET*	RF_RESET*	RF_RESET*
BLUE_CLK_EN*	BLUE_CLK_EN*	BLUE_CLK_EN*
WB_RX_ON	WB_RX_ON	WB_RX_ON
WB_TX_RAMP	WB_TX_RAMP	WB_TX_RAMP
WB_RX_ACO	WB_RX_ACO	WB_RX_ACO
WB_TX_SLOT	WB_TX_SLOT	WB_TX_SLOT
WB_RX_SLOT	WB_RX_SLOT	WB_RX_SLOT
AOC_PWR_UP	AOC_PWR_UP_DOWN	AOC_PWR_UP_DOWN
WB_TX_PREKEY	WB_TX_PREKEY	WB_TX_PREKEY
NB_RX_ACO	NB_RX_ACO	NB_RX_ACO
NB_TX_KEYM	NB_TX_KEYM	NB_TX_KEYM
NB_TX_EN*	NB_TX_EN*	NB_TX_EN*
NB_EXC_EN*	NB_EXC_EN*	NB_EXC_EN*
DET_FLAG	DET_FLAG	DET_FLAG
CLK_SEL	CLK_SEL	CLK_SEL
MAGIC_CS	MAGIC_CS	MAGIC_CS
NB_SPI_MOSI	NB_SPI_MOSI	NB_SPI_MOSI
NB_SPI_CLK	NB_SPI_CLK	NB_SPI_CLK
REF_15_36	REF_15_36 (For GPS)	REF_15_36
DMCS_MAGIC	DMCS_MAGIC	DMCS_MAGIC
BDX	BDX	BDX
BFSR	BFSR	BFSR
BCLKX	BCLKX	BCLKX
BCLKR	BCLKR	BCLKR
BDR	BDR	BDR
BFSX	BFSX	BFSX
BB_CLK_13M	BB_CLK_13M	BB_CLK_13M
BLUETOOTHCLK	BLUETOOTHCLK	BLUETOOTHCLK
HL_TX_EN	HL_TX_EN	HL_TX_EN

Engineer: Ed Naddeo	TITLE: Talon Integrated Top Level		
Drawn by: Ed Naddeo			
R&D CHK:	Size: 11x17		
DOC CTRL CHK:			
MFG CTRL CHK:			
QA CHK:	REV: P6C	Drawing Number: 8487729N06	Page: Of:
Changed by: Ed Naddeo	Date: January 7, 2003	Time: 10:43:18 am	

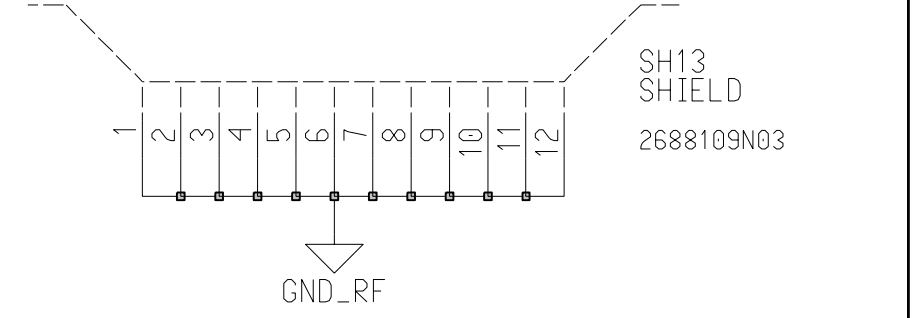
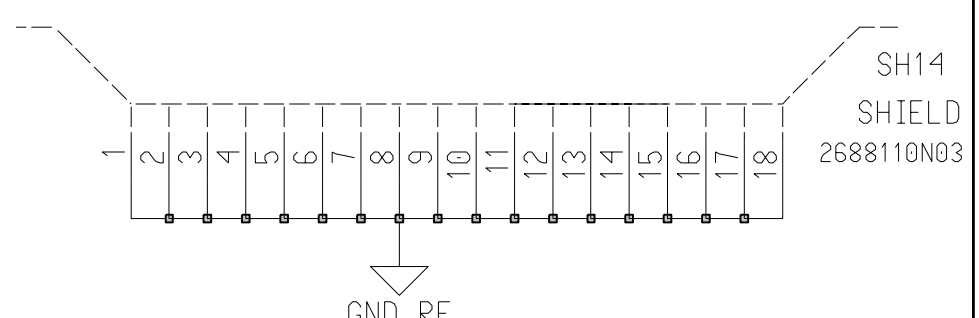
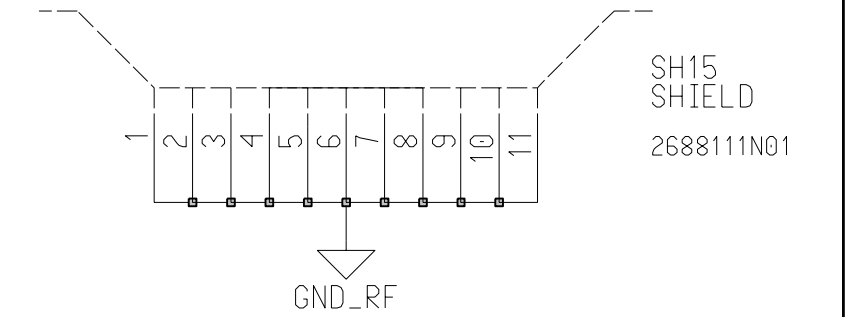
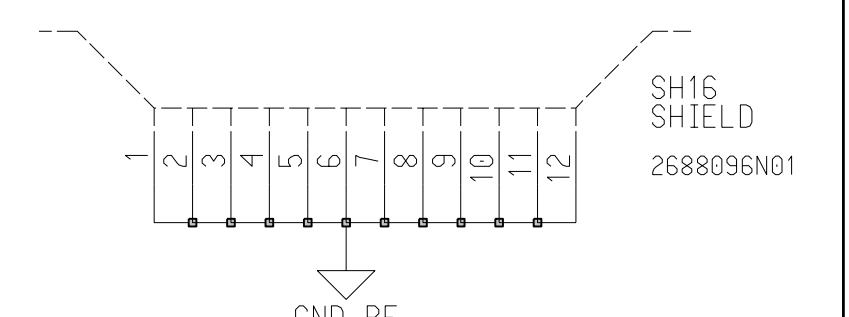
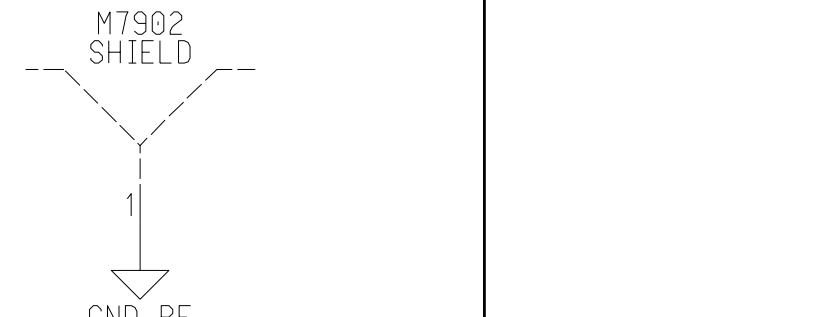
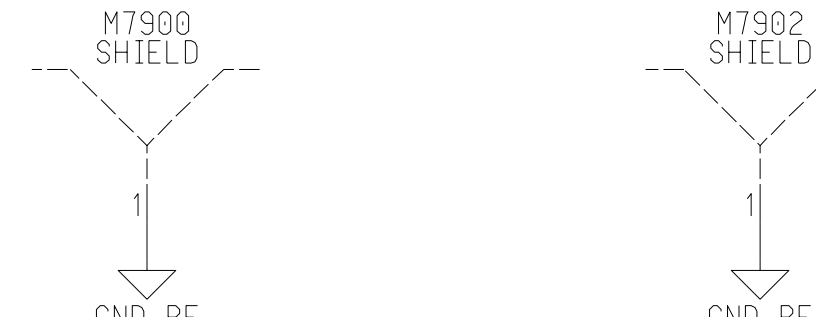
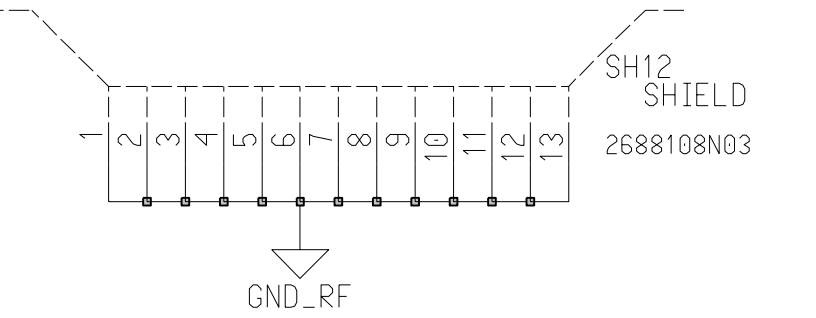
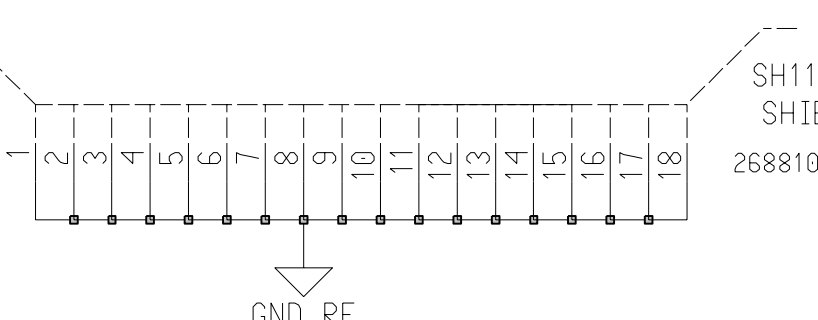
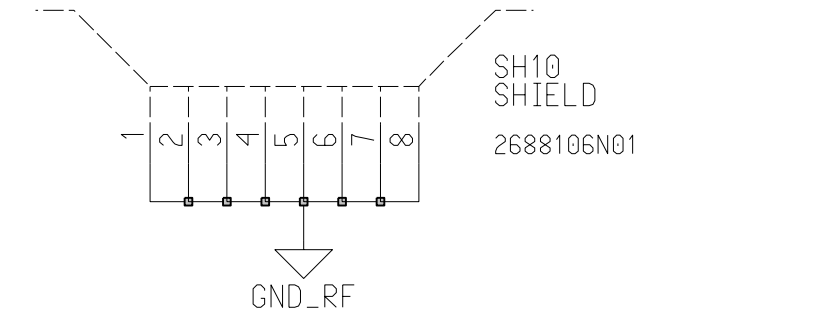
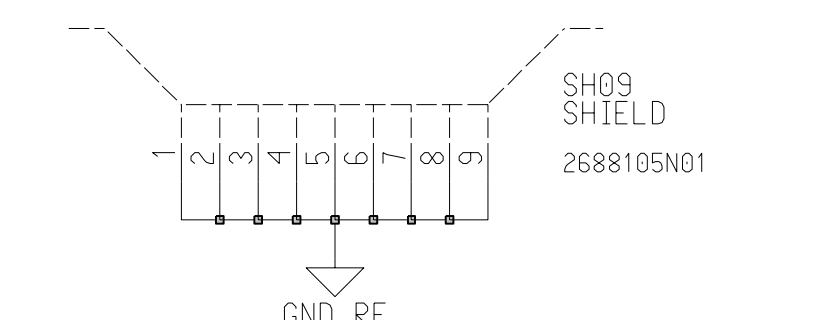
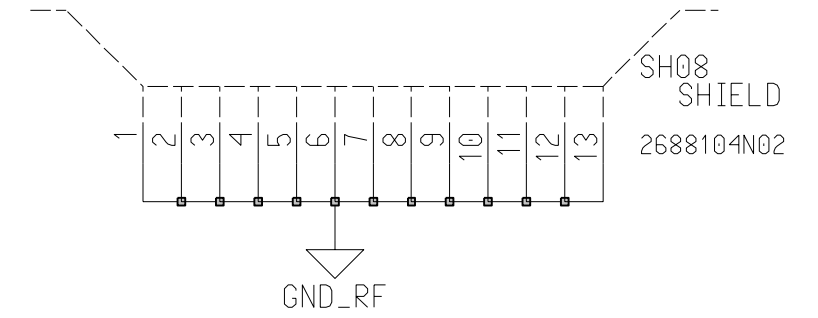
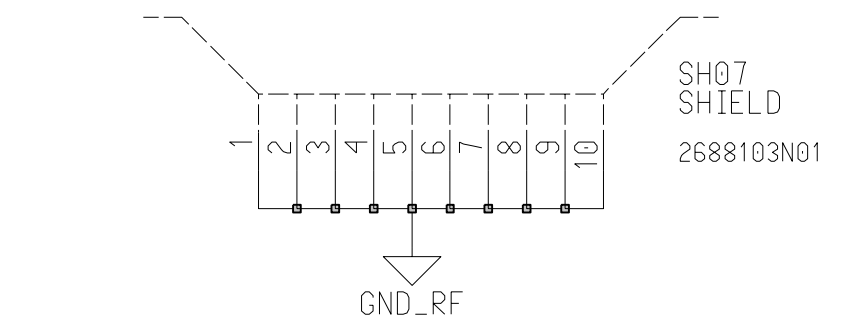
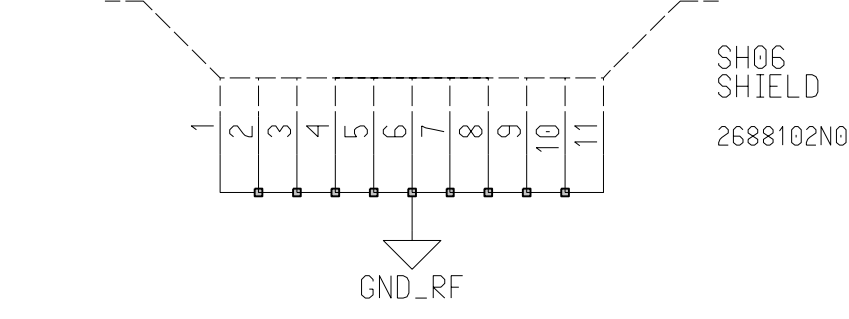
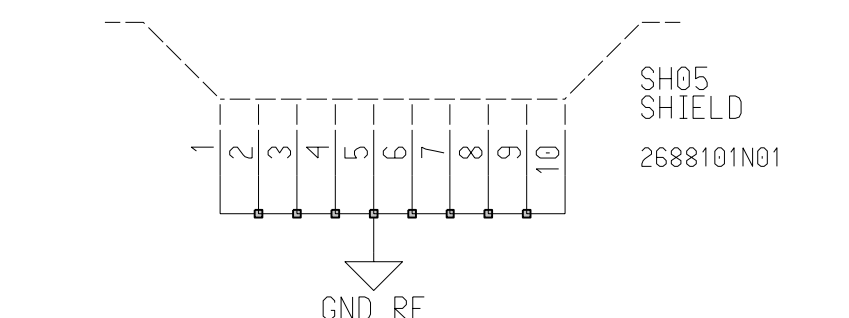
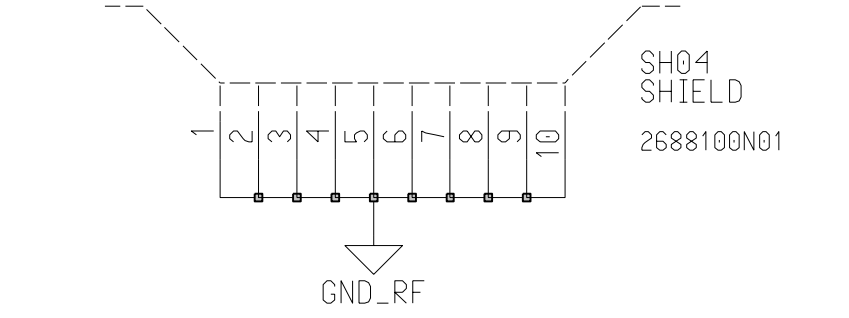
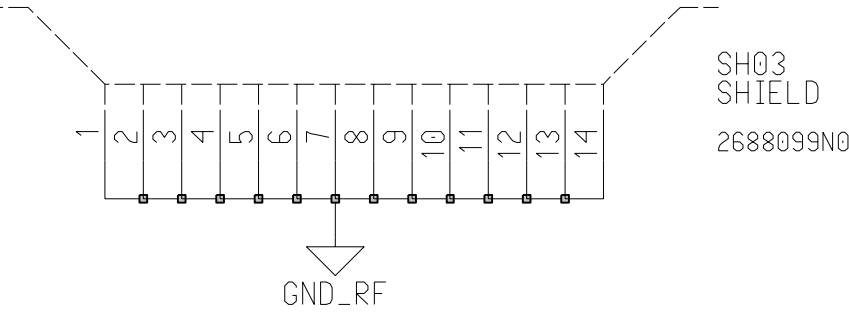
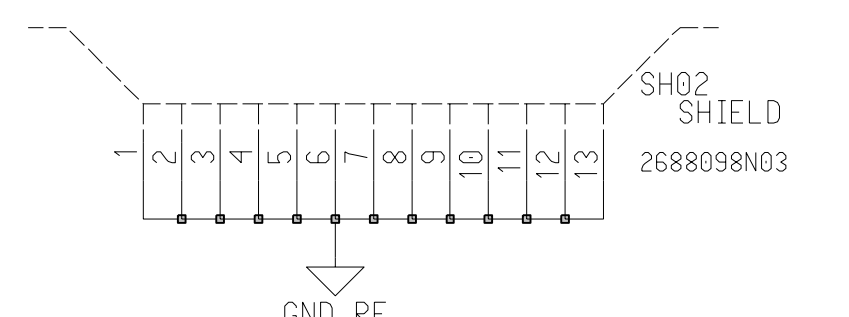
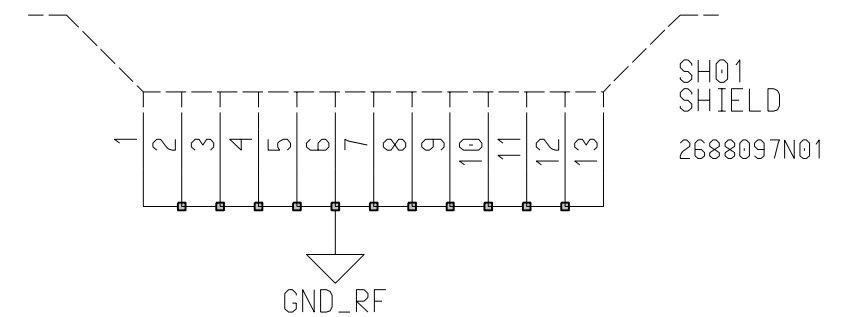

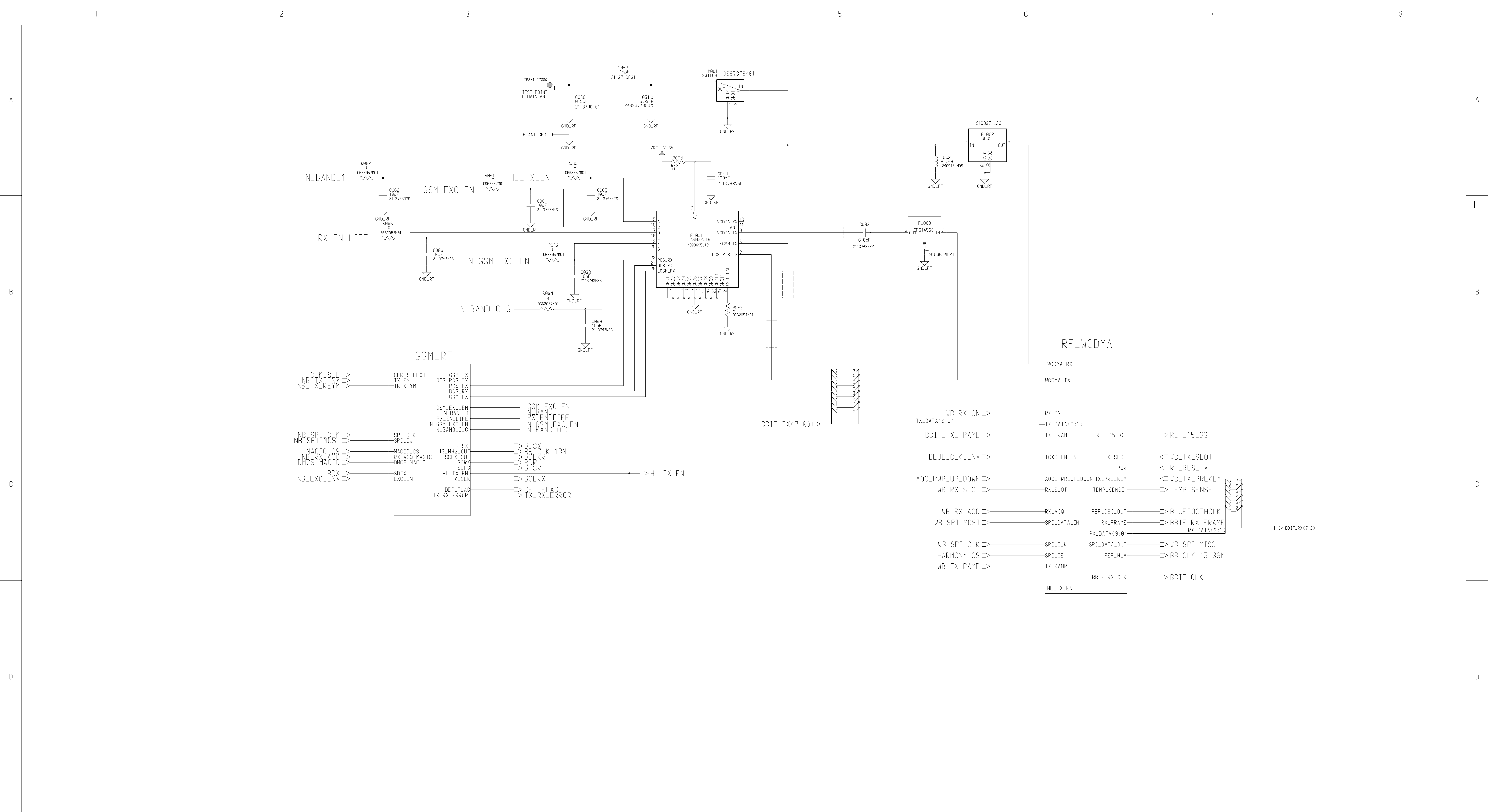

Engineer Dave Suarez	MOTOROLA INC. 600 N US HWY 45 Libertyville, IL		
Drawn by Dave Suarez			
R&D CHK	TITLE	Size D	
DOC CTRL CHK	RF_TOP		
MFG CTRL CHK			
QA CHK	REV P6C	Drawing Number 8487729N06	Sheet of

Changed by Dave Suarez Date Changed July 30, 2003 Time 3:59:05 pm

Band Select Circuits REF # 900-925

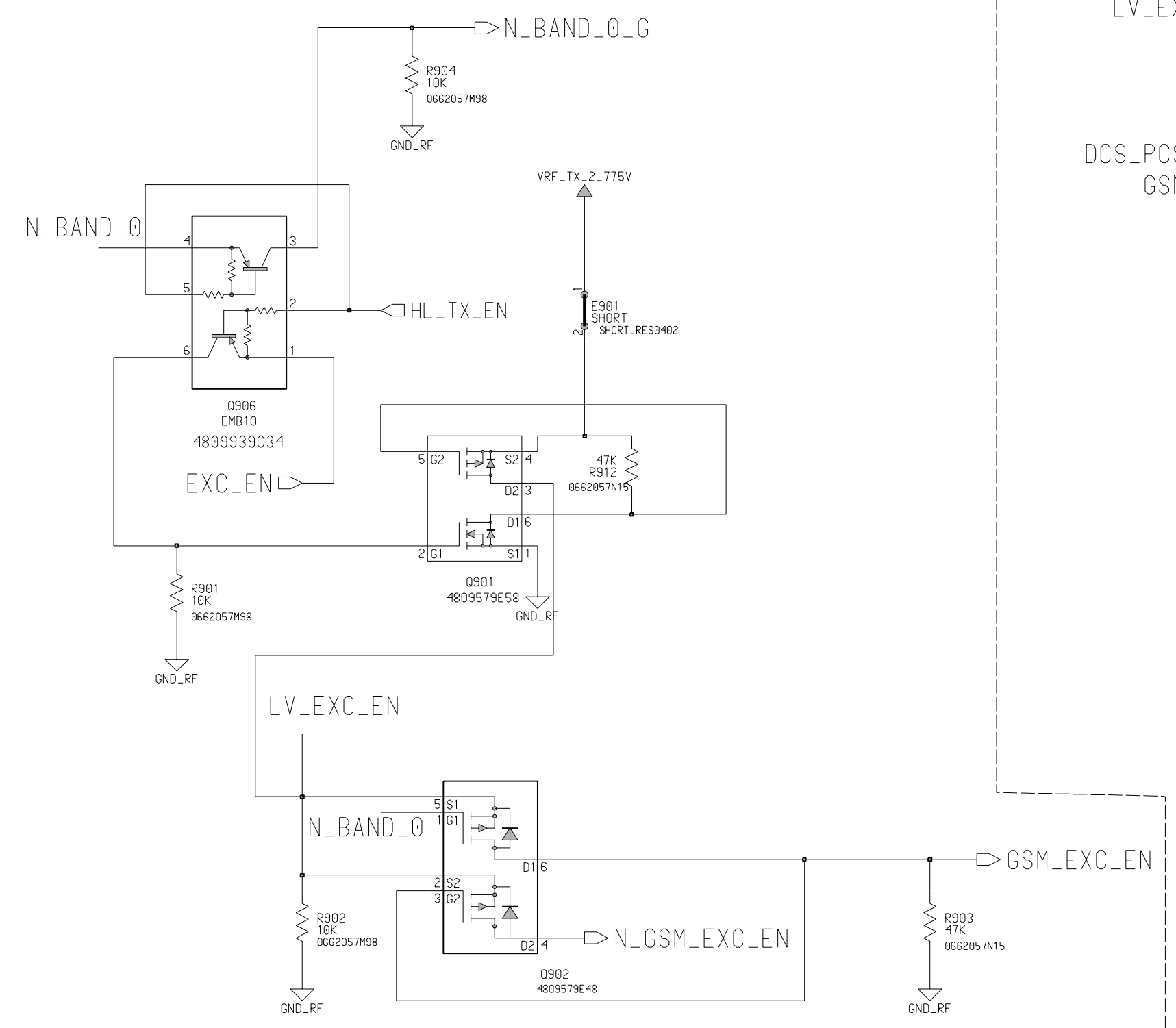
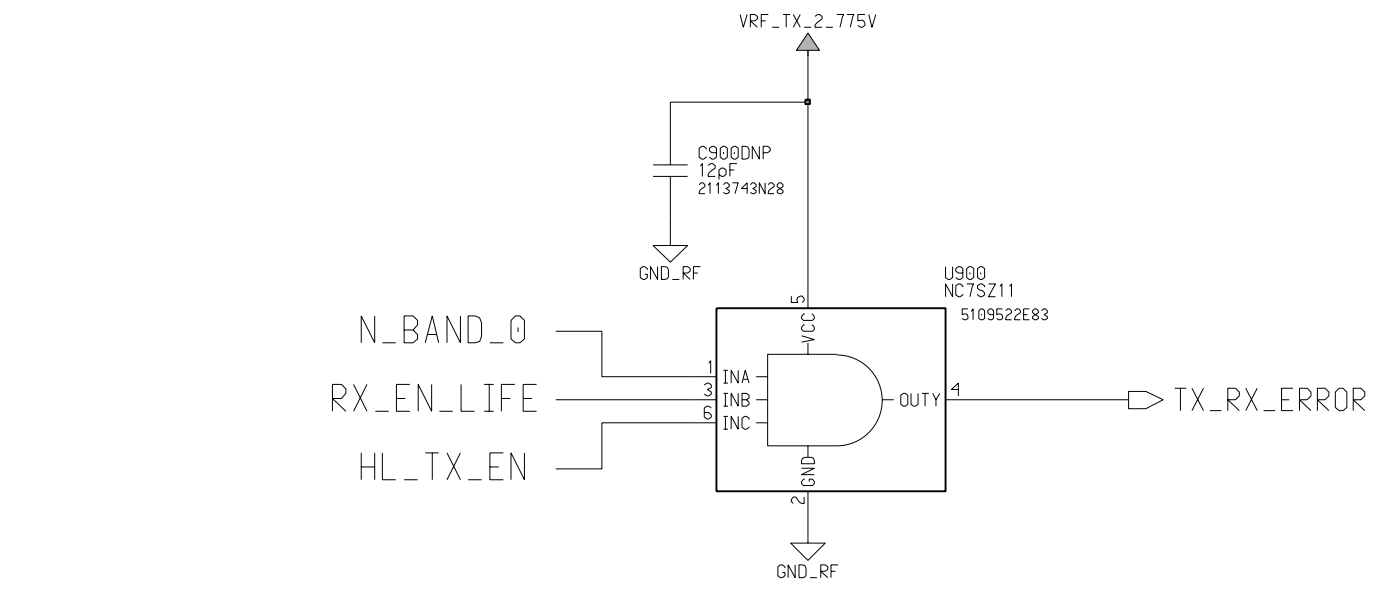
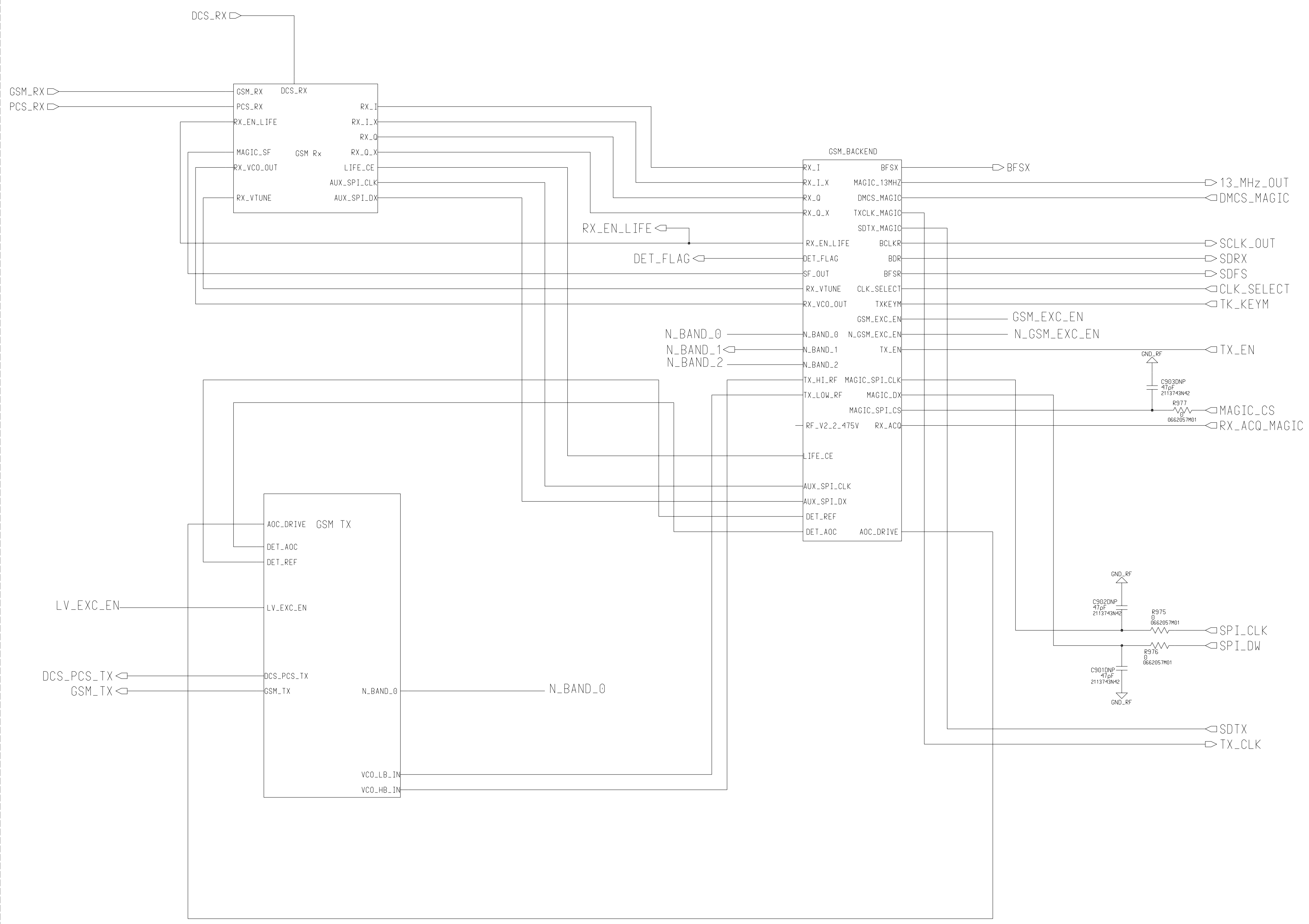

Engineer Dave Suarez	COMPANY NAME		
Drawn by Dave Suarez	Address City		
R&D CHK	TITLE	Size	
DOC CTRL CHK	GSM_TOP	D	
MFG CTRL CHK			
QA CHK	REV P3	Drawing Number 8487729N01	Sheet of

Changed by Dave Suarez Date Changed February 5, 2003 Time

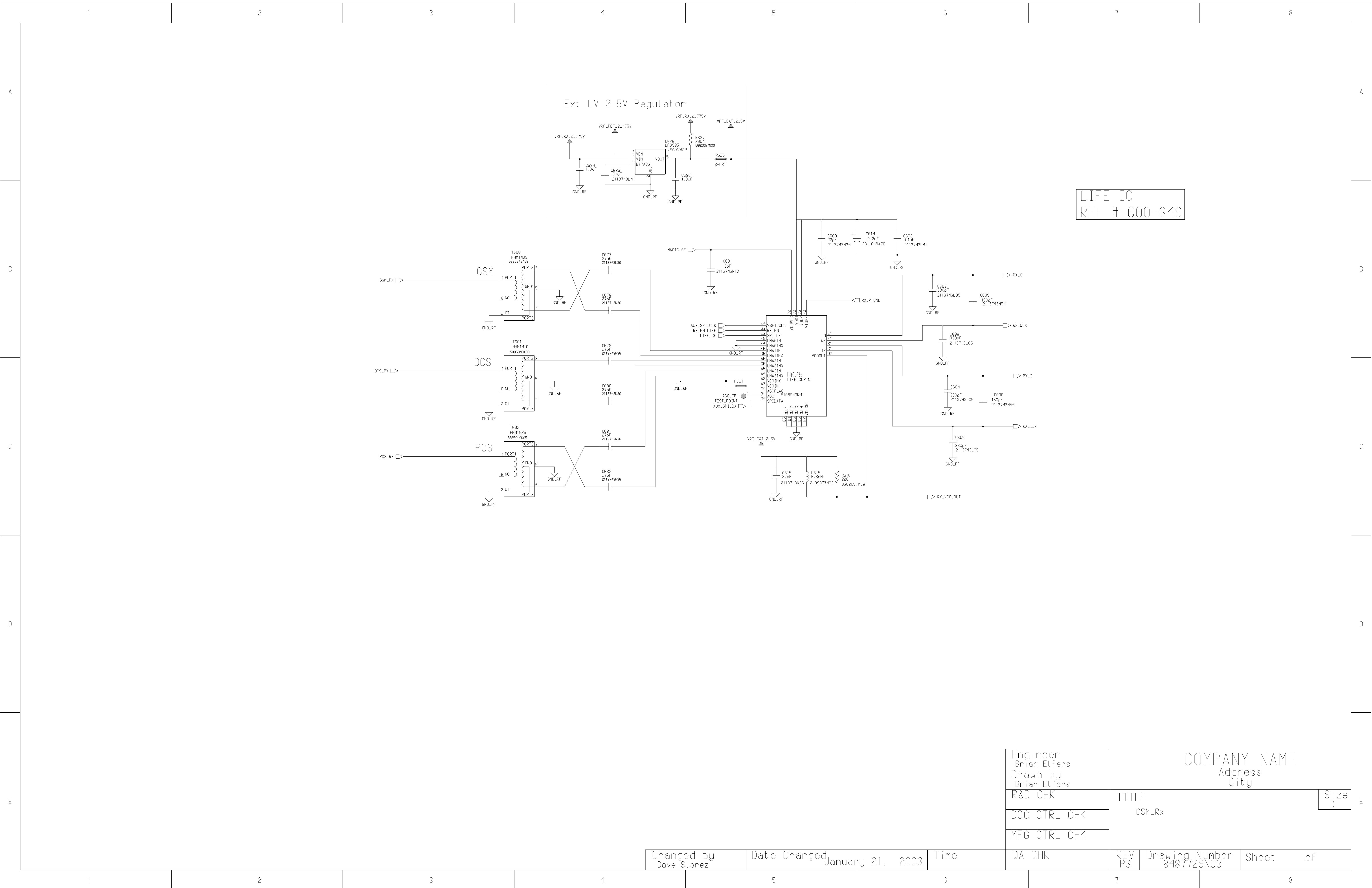

LIFE IC
REF # 600-649

Engineer Brian Elfers	COMPANY NAME Address City		
Drawn by Brian Elfers			
R&D CHK	TITLE	Size D	
DOC CTRL CHK	GSM_Rx		
MFG CTRL CHK			
QA CHK	REV P3	Drawing Number 8487729N03	Sheet of

Changed by Dave Suarez Date Changed January 21, 2003 Time

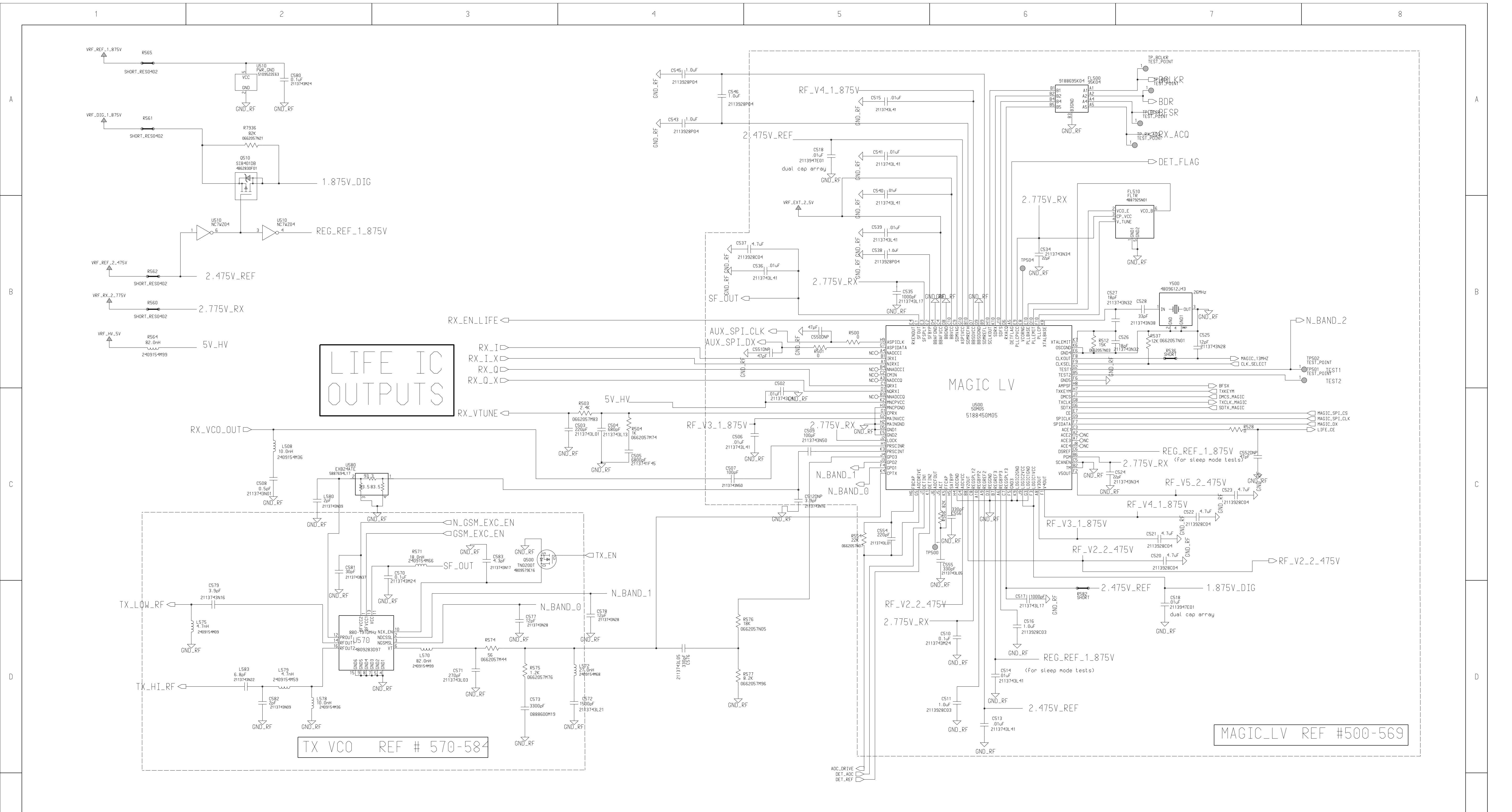

LIFE IC
OUTPUTS

MAGIC LV

TX VCO REF # 570-584

MAGIC_LV REF #500-569

Engineer Andy Ma	MOTOROLA INC. LIBERTYVILLE IL		
Drawn by Andy Ma	TITLE		Size D
R&D CHK	Talon_rev_0 GSM_backend		
DOC CTRL CHK			
MFG CTRL CHK			
QA CHK	REV PGC	Drawing Number 8487729N06	Sheet of

Changed by Dave Suarez Date Changed July 30, 2003 Time

GSM Transmitter

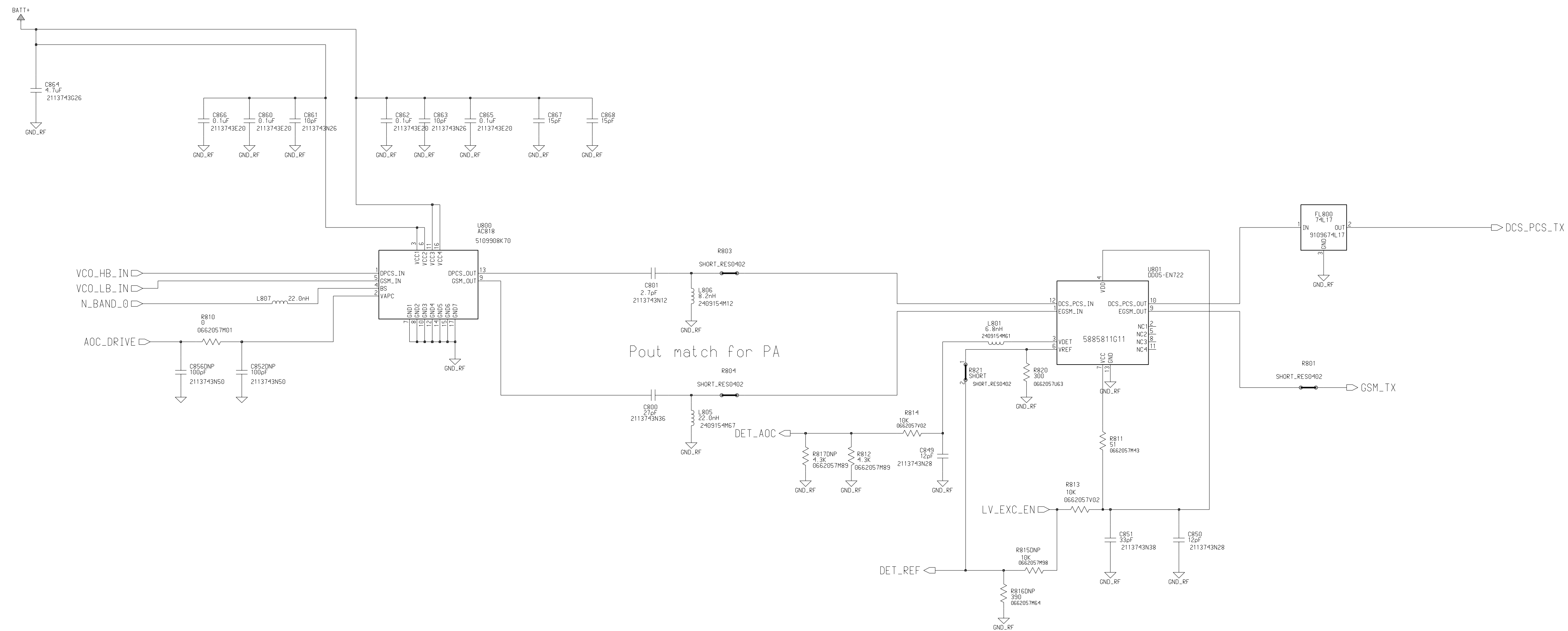

Engineer Paul Manente	COMPANY NAME Address City			Size D
Drawn by Paul Manente				
R&D CHK	TITLE			
DOC CTRL CHK	GSM_TX_D			
MFG CTRL CHK	GSM_Transmitter			
QA CHK	REV PGB	Drawing Number 8487729N06	Sheet	of

Changed by Dave Suarez Date Changed June 26, 2003 Time

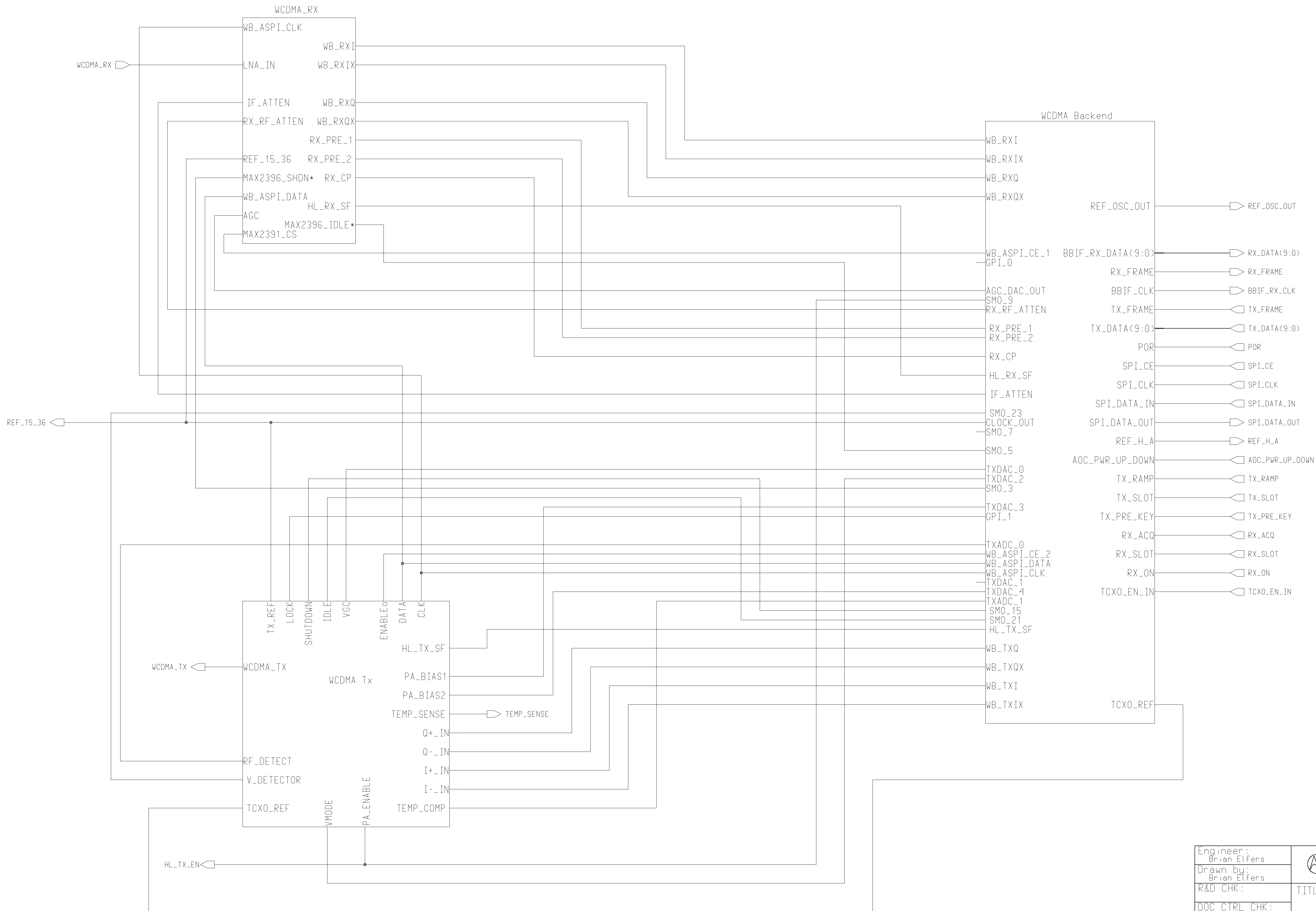

Engineer: Brian Elfers			
Drawn by: Brian Elfers			
R&D CHK:	TITLE: Talon_rev_0	Size: 11x17	
DOC CTRL CHK:			
MFG CTRL CHK:			
QA CHK:	REV: P3	Drawing Number: 8487729N03	Page: Of:
Changed by: Dave Suarez	Date: Friday, April 20, 2001	Time: 4:07:28 pm	

1
MOTOROLA INTERNAL USE ONLY

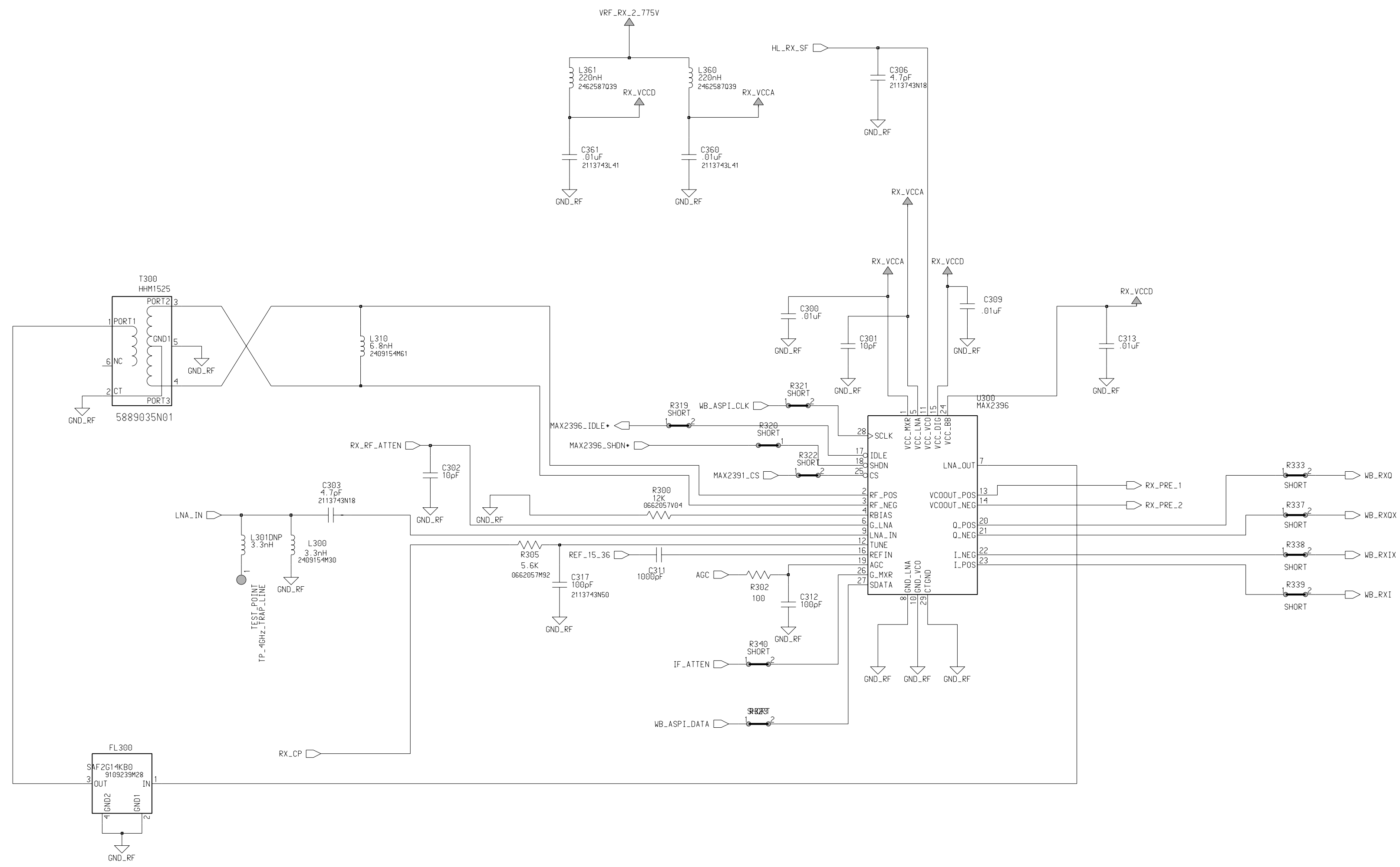

Engineer:	Randy Messner	
Drawn by:	Randy Messner	
R&D CHK:		TITLE: WCDMA_Rx Size: 0
DOC CTRL CHK:		
MFG CTRL CHK:		
QA CHK:		REV: 0 Drawing Number: 3487723N03 Page: 01
Changed by:	Dave Suarez	Date: June 12, 2003 Time: 4:33:16 pm

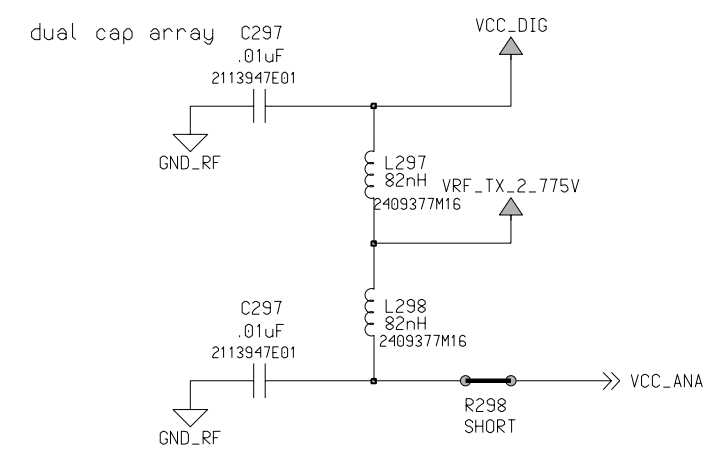

WCDMA Transmitter (TALON)

Interstage filter 1920 - 1980

Quadrature modulator and upmixer 200-299

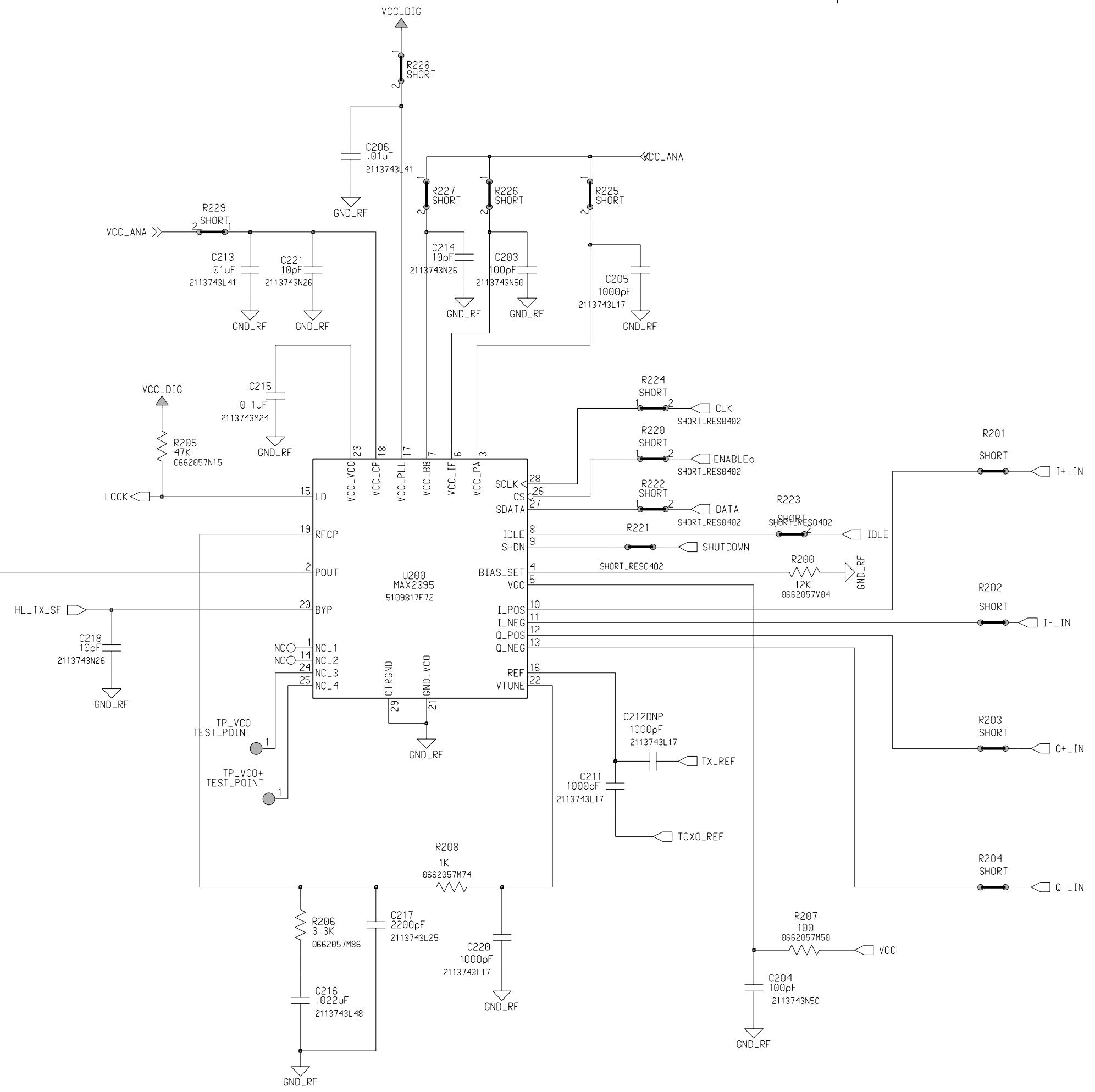
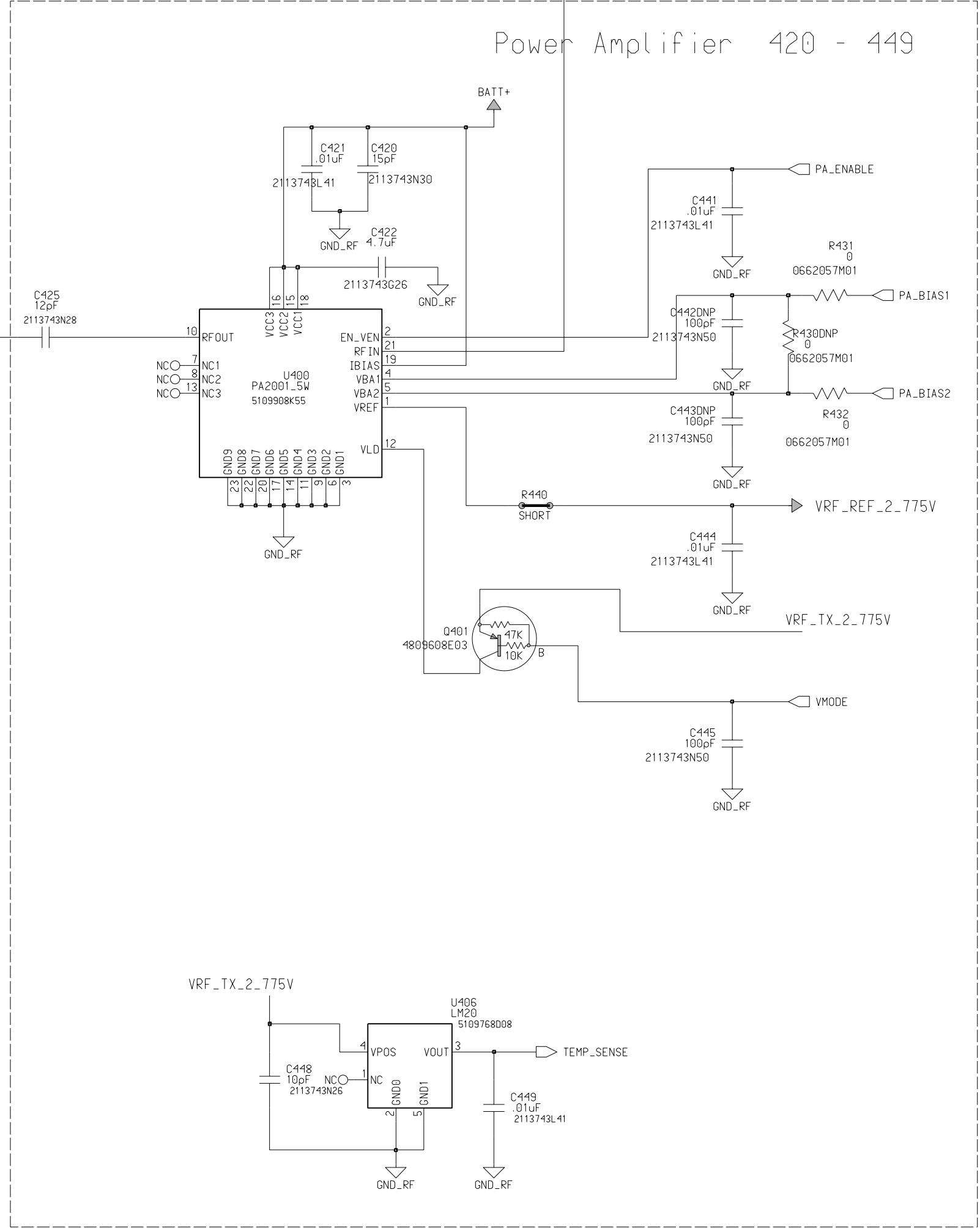
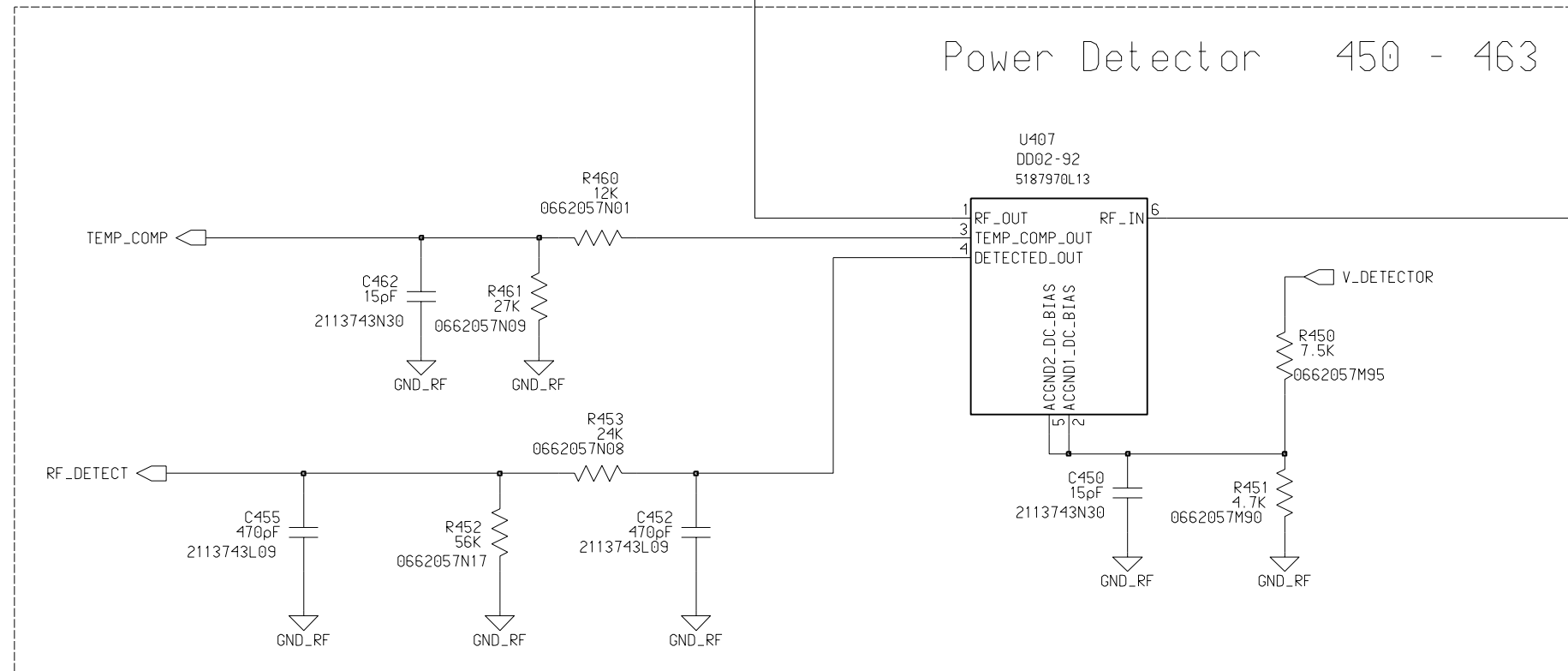
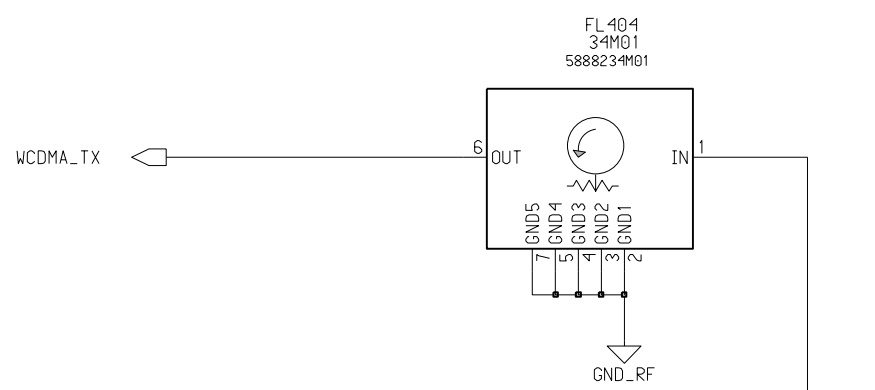

Engineer John Mura	COMPANY NAME Address City	
Drawn by John Mura	TITLE WCDMA-Tx	Size D
R&D CHK		
DOC CTRL CHK		
MFG CTRL CHK		
QA CHK	REV P6	Drawing Number 8487729N06
Changed by Dave Suarez	Date Changed June 12, 2003	Time 4:39:58 pm
	Sheet 1	of 1

Changed by Dave Suarez Date Changed June 12, 2003 Time 4:39:58 pm

MOTOROLA CONFIDENTIAL PROPRIETARY

Engineer:
John S. Kerr
Drawn by:
Todd Roessler
R&D CHK:
DOC CTRL CHK:
MFG CTRL CHK:
QA CHK:
Changed by:
Ed Naddeo



TITLE: Talon Integrated Baseband Top Level
Size: 11x17
REV: Drawing Number: Page: Of:
Date: Monday, March 4, 2002
Time: 10:39:56 am

Misc Connectors

- Display Connector USIM
- Keypad Connector IrDA
- Headset Jack Vibrator
- Fun Lights

CORE LOGIC BLOCK

- POG
- Memories
- Video
- AGPS
- Embedded SD

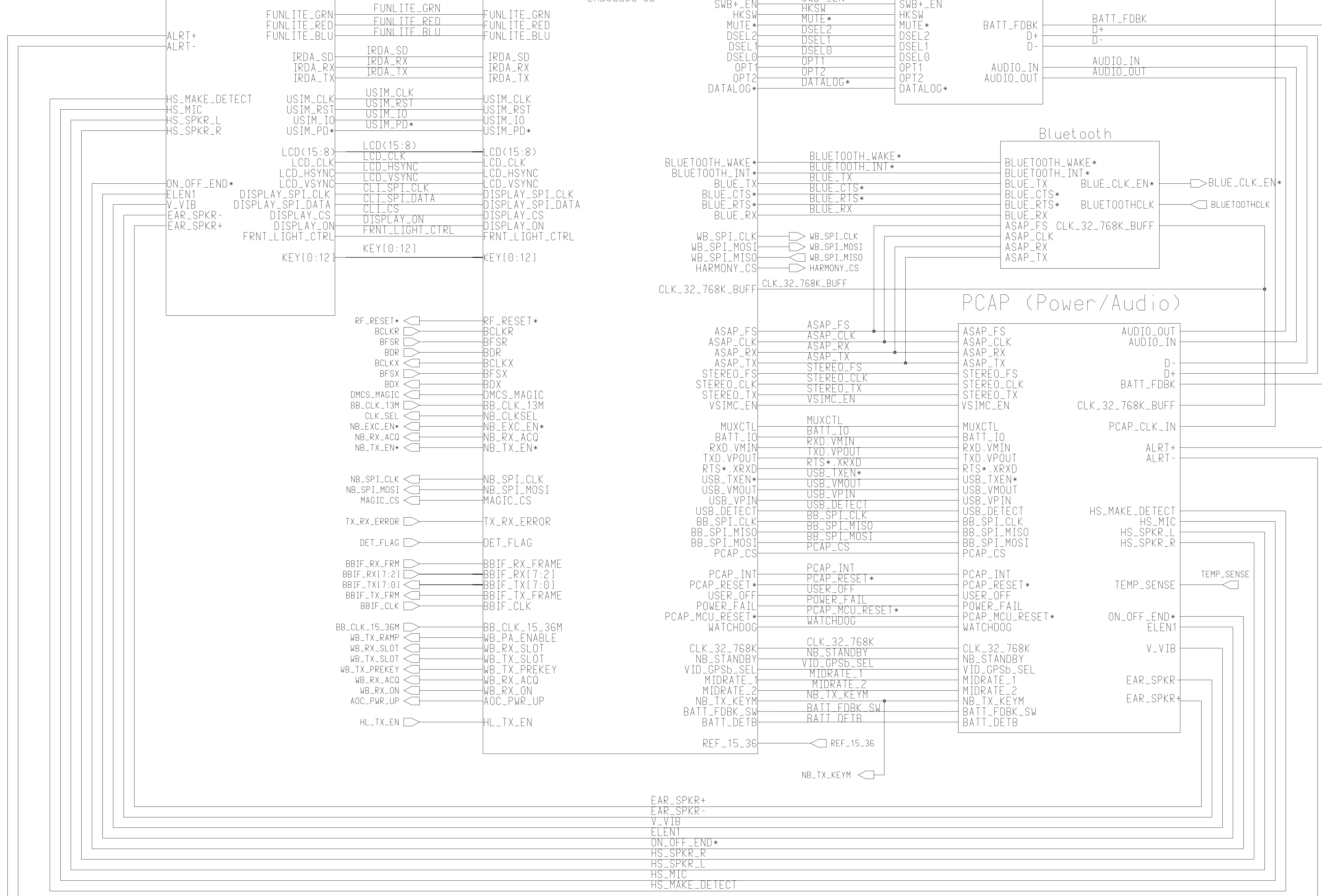

A

B

C

D

- EAR_SPKR+
- EAR_SPKR-
- V_VIB
- ELEN1
- ON_OFF_END*
- HS_SPKR_R
- HS_SPKR_L
- HS_MIC
- HS_MAKE_DETECT

- ALRT-
- ALRT+

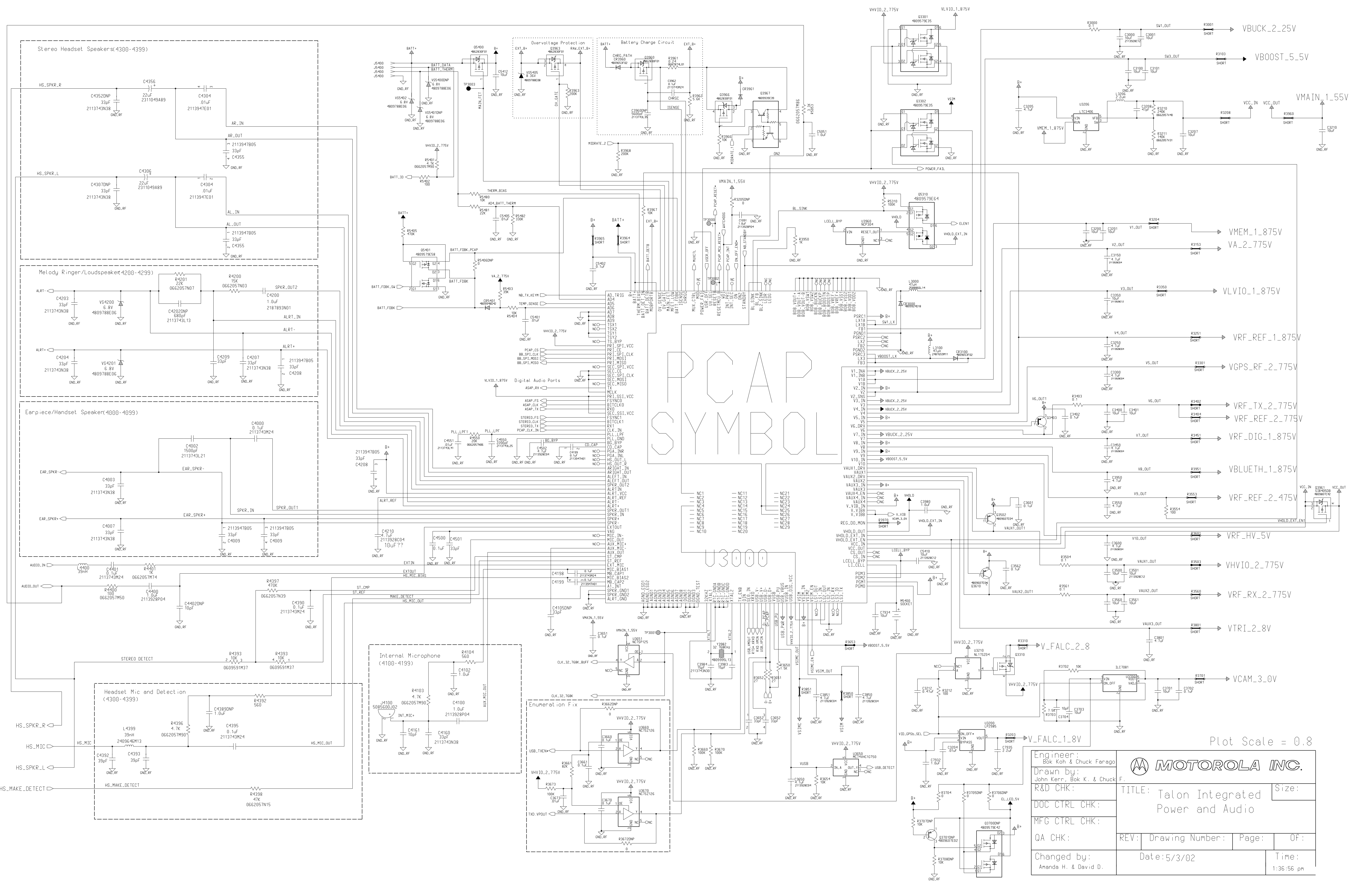

TALON
SYMBOL

Plot Scale = 0.8

Engineer: Bok Koh & Chuck Farago		MOTOROLA INC.	
Drawn by: John Kerr, Bok K. & Chuck F.		TITLE: Talon Integrated Power and Audio	
R&D CHK:	DOC CTRL CHK:	Size:	
MFG CTRL CHK:	QA CHK:	REV: Drawing Number:	Page: Of:
Changed by: Amanda H. & David D.		Date: 5/3/02	Time: 1:36:56 pm

Engineer: Dave Stubbs	MOTOROLA INC.		
Drawn by:	TITLE: TALON Integrated Bluetooth	Size:	
R&D CHK:	REV:	Drawing Number:	Page: Of:
DOC CTRL CHK:			
MFG CTRL CHK:			
QA CHK:			
Changed by: Dave Suarez	Date: February 24, 2003	Time:	

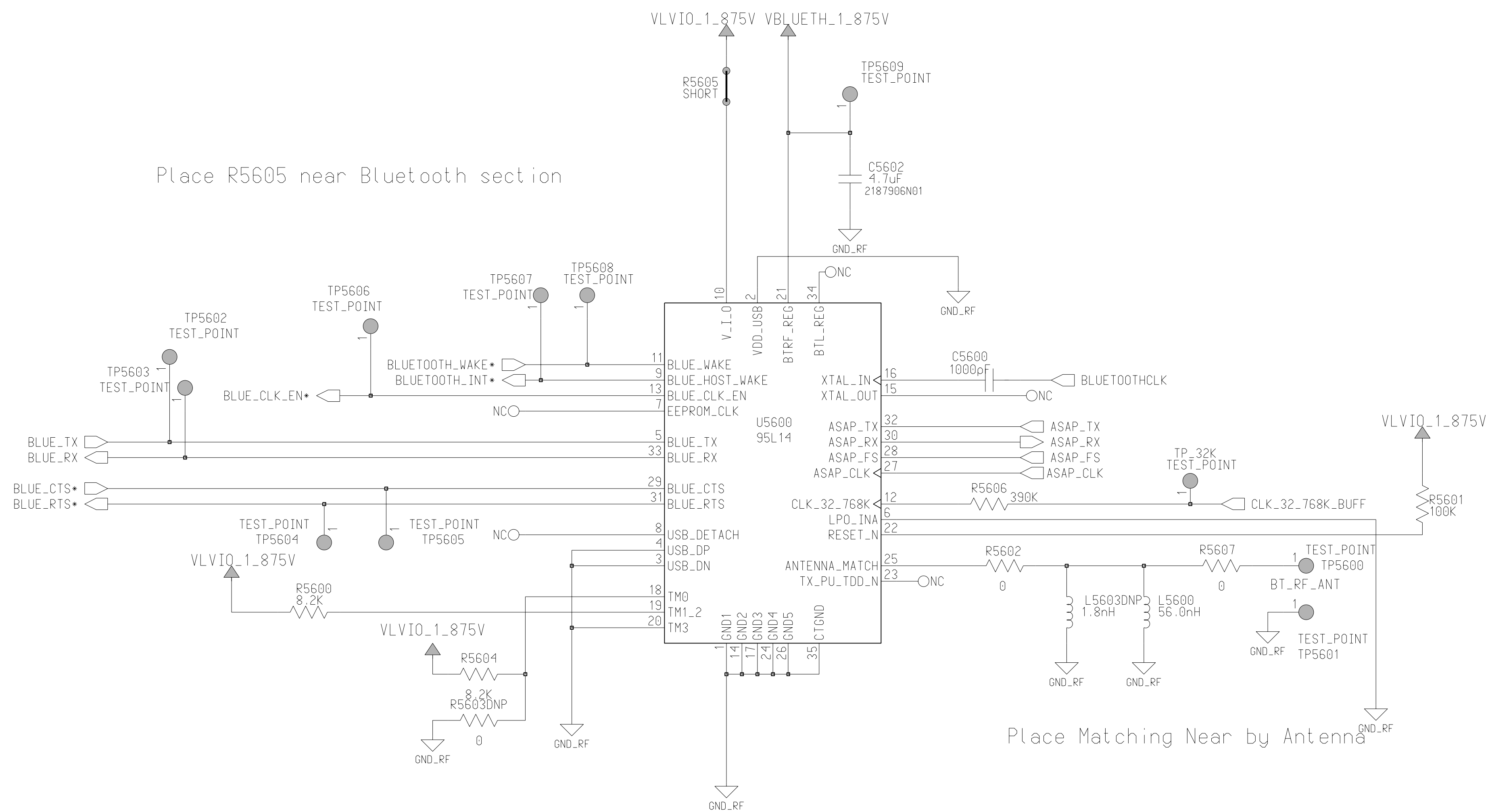

MOTOROLA CONFIDENTIAL PROPRIETARY



Engineer: Ed Naddeo	TITLE: TALON INTEGRATED		Size: 11x21
Drawn by: Ed Naddeo	Misc Connectors		
R&D CHK:	DOC CTRL CHK:	MFG CTRL CHK:	QA CHK:
Changed by: Ed Naddeo	Date: Monday, April 23, 2001	Page: 1	Of: 1
			Time: 11:27:59 am

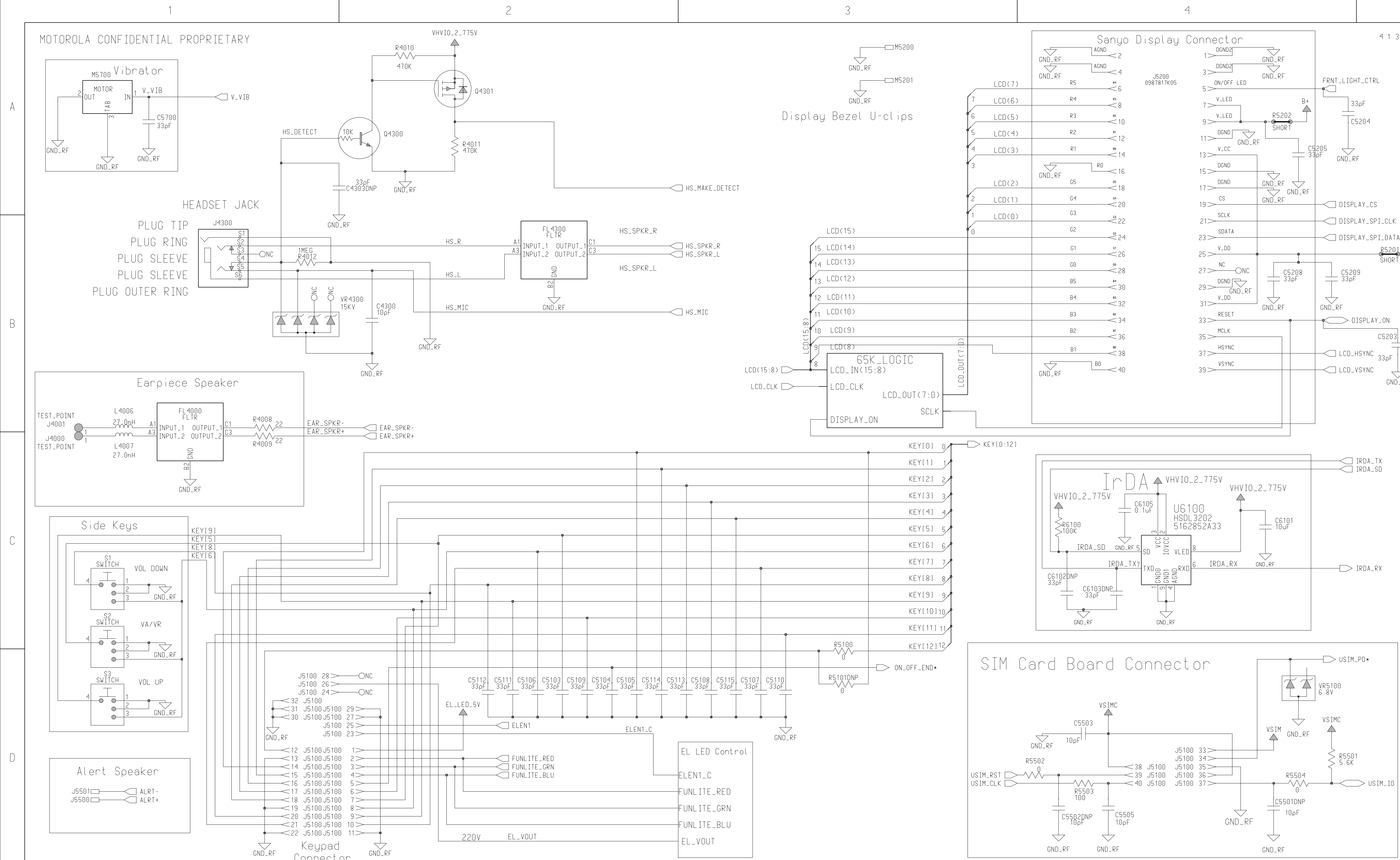

A

B

C

D

MOTOROLA CONFIDENTIAL PROPRIETARY

Accessory Connector CE Connector (0987636K05)

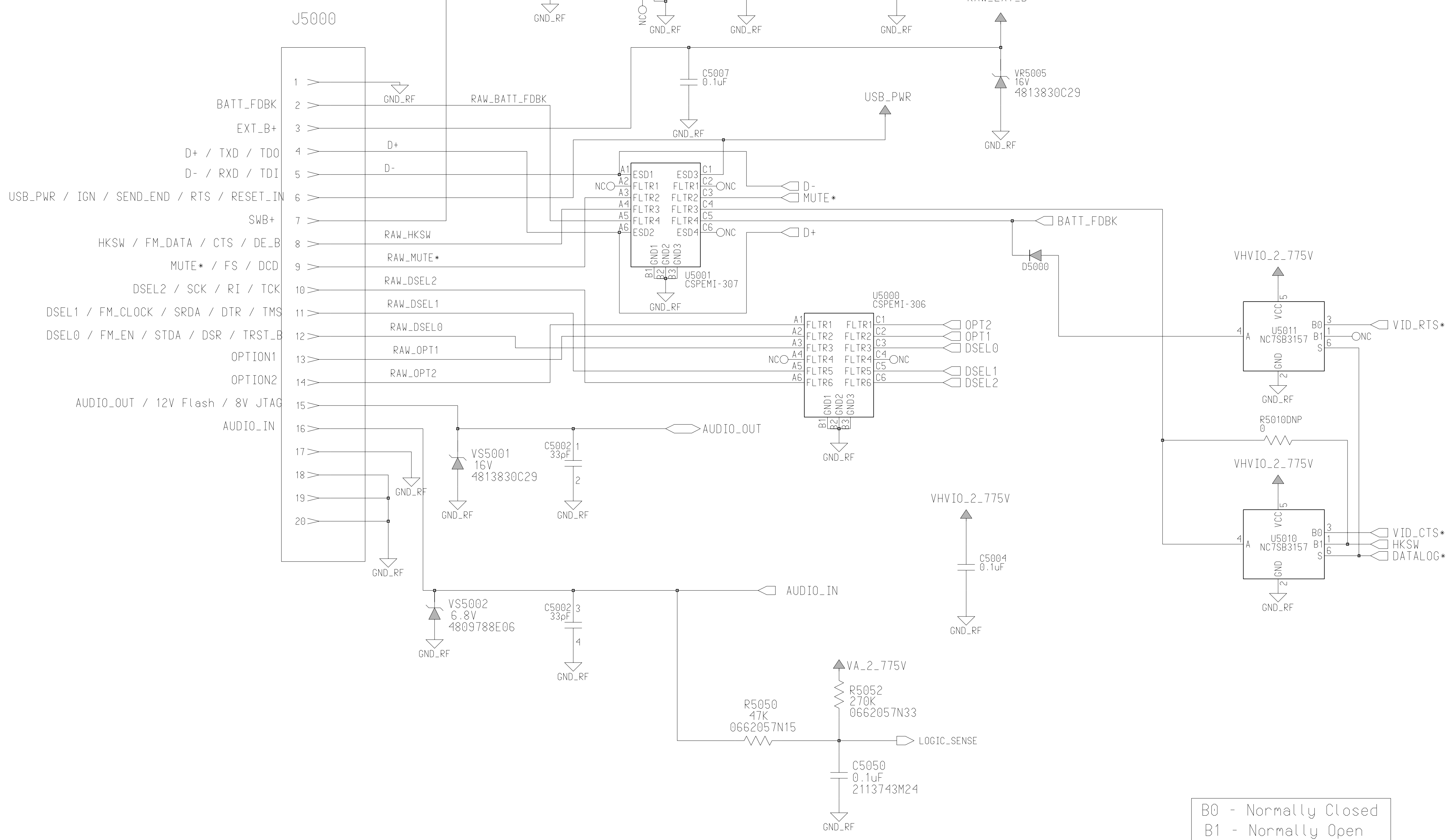

Engineer: Jennifer Seymour	MOTOROLA INC.		
Drawn by:			
R&D CHK:	TITLE: TALON Integrated	Size:	
DOC CTRL CHK:	CE Accessory Connector		
MFG CTRL CHK:	REV:	Drawing Number:	Page: Of:
QA CHK:	Ed Naddeo	4/3/02	

B0 - Normally Closed
B1 - Normally Open
S - Select
A - Common

Engineer: Ed Naddeo	TITLE: Talon Integrated Core Logic		Size: 11x21
Drawn by: Ed Naddeo			
R&D CHK:			
DOC CTRL CHK:			
MFG CTRL CHK:			
QA CHK:	REV: 1.0	Drawing Number: 848888x88	Page: 1
Changed by: wlen01	Date: Friday, March 1, 2002	Time: 1:16:44 pm	

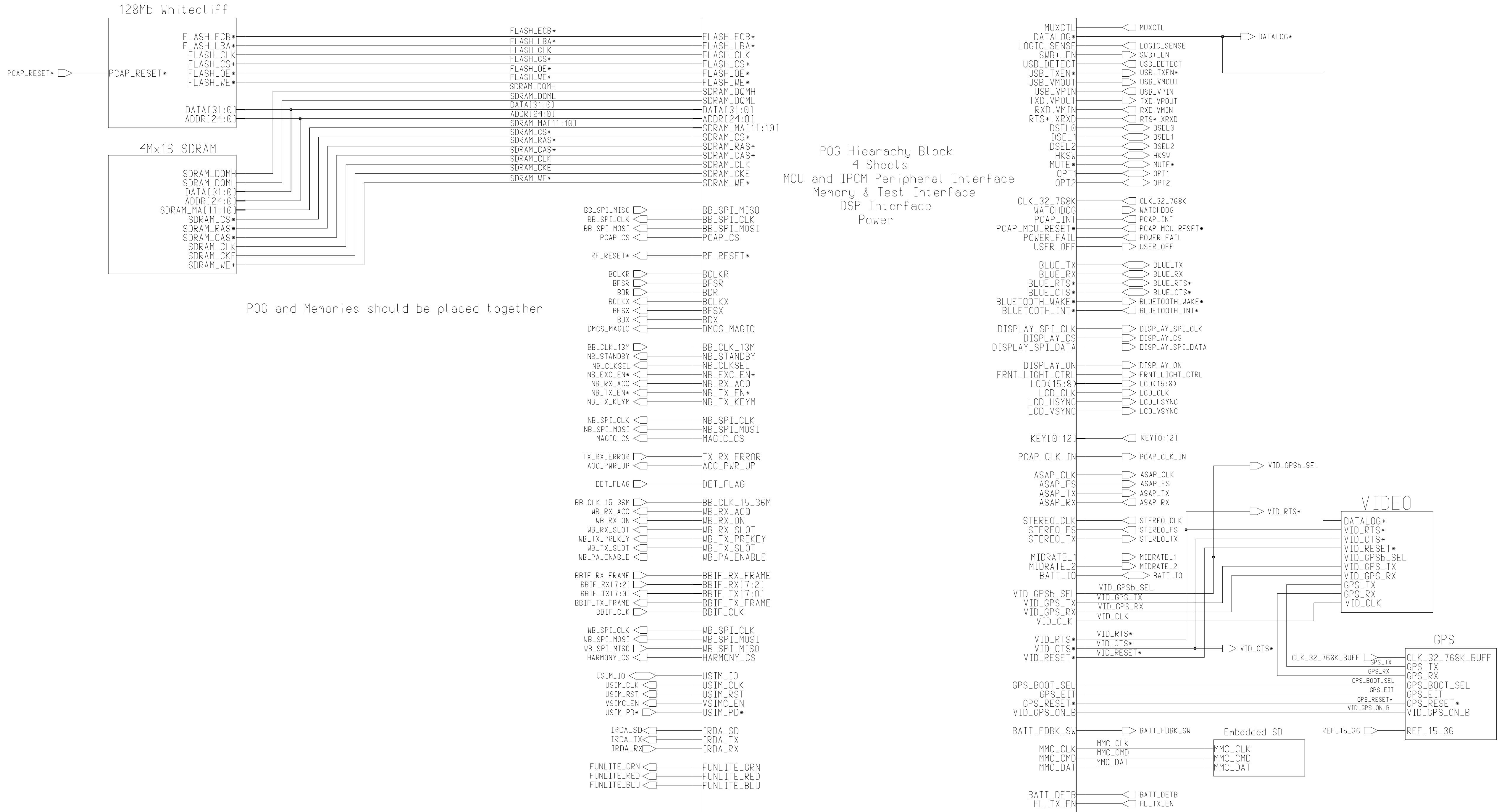

Engineer: Ed Naddeo	MOTOROLA INC.		
Drawn by: Ed Naddeo			
R&D CHK:	TITLE: TALON Integrated POG	Size: 11x17	
DOC CTRL CHK:	Accessories Interface		
MFG CTRL CHK:	REV: 1.0	Drawing Number: 8488888x88	Page: 2
QA CHK:	Date: Tuesday, February 26, 2002	Of: 4	Time: 4:39:04 pm
Changed by: wlen01			

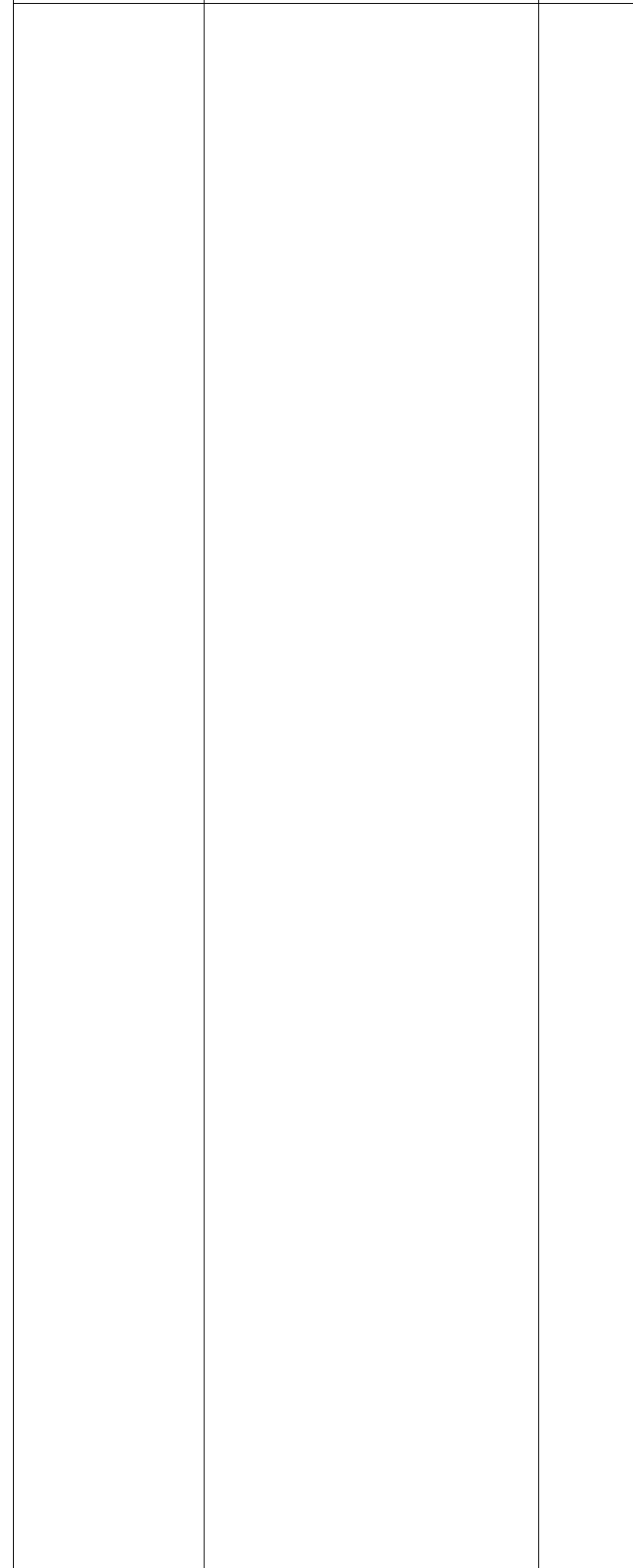
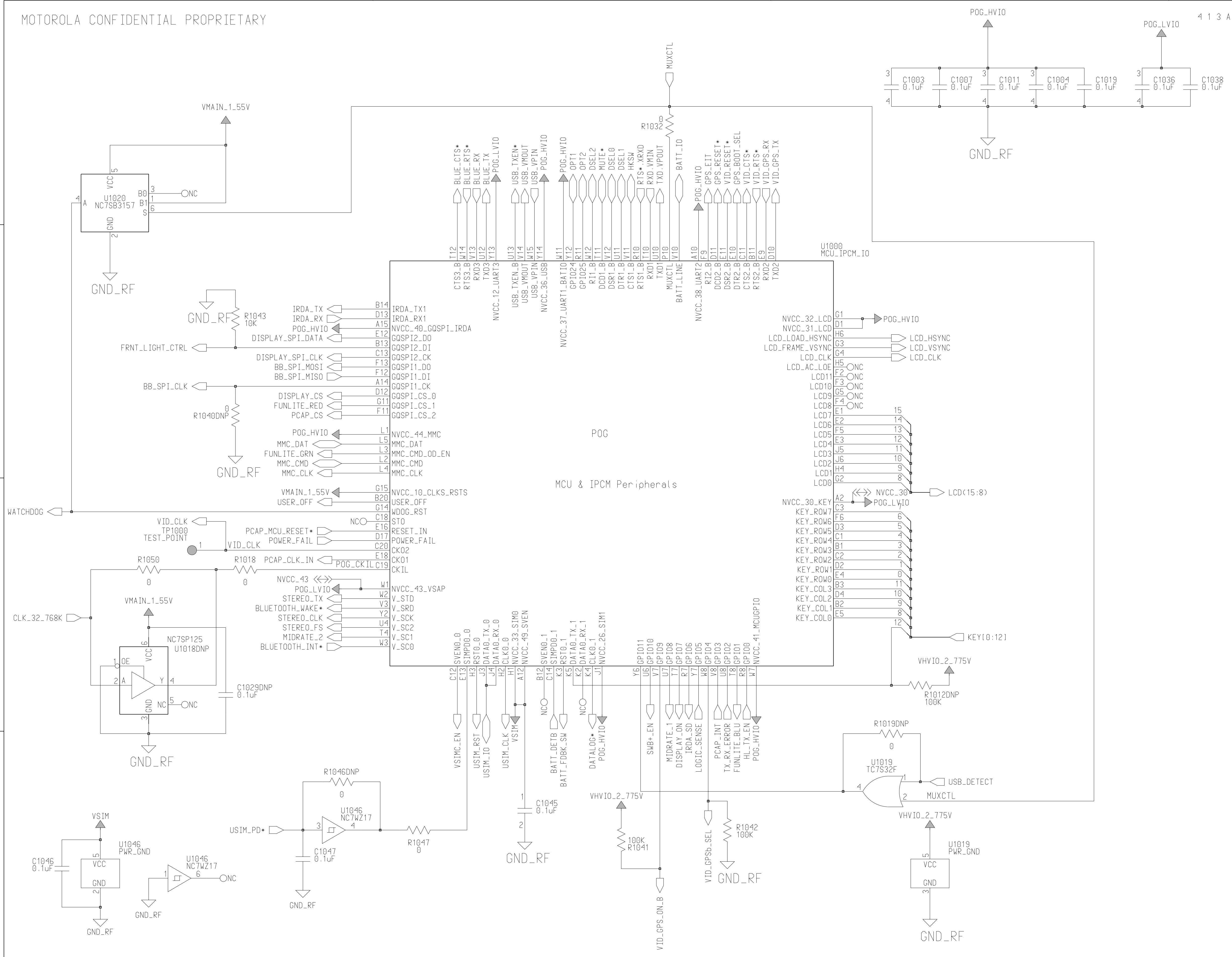

Engineer: Ed Nadeo			
Drawn by: Ed Nadeo			
R&D CHK:	TITLE: Talon Integrated POG	Size: 11x17	
DOC CTRL CHK:	Memory and Test Interface		
MFG CTRL CHK:	REV: 1.0	Drawing Number: 8488888x88	Page: 3
QA CHK:	Date: Tuesday, February 26, 2002		Of: 4
Changed by: wlen01	Date:		Time: 6:15:09 pm

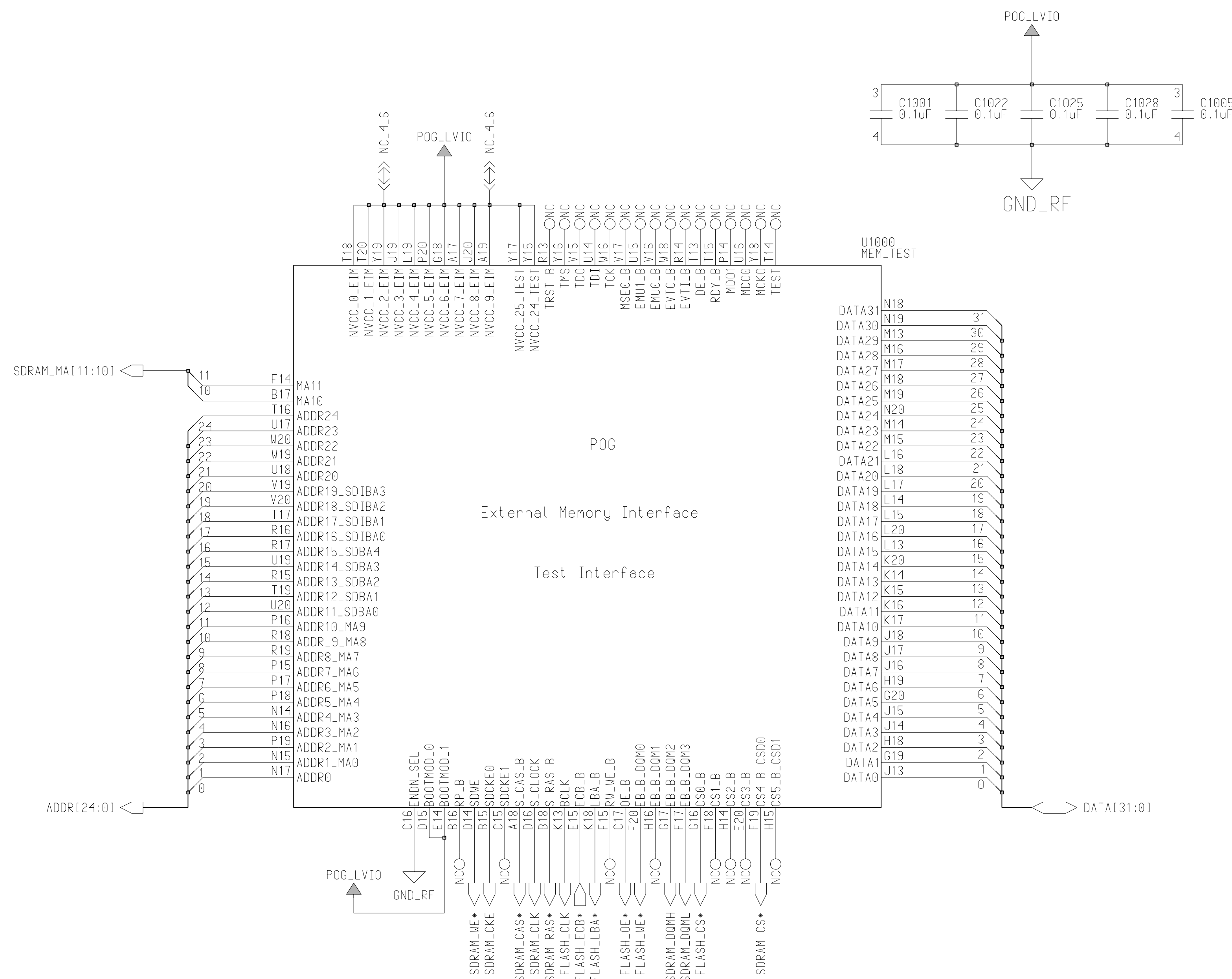

A

B

C

D

Engineer:
Ed Nadeo

Drawn by:
Ed Nadeo

R&D CHK:

DOC CTRL CHK:

MFG CTRL CHK:

QA CHK:

Changed by:
wlen01



TITLE: Talon Integrated POG DSP Interface

Size: 11x17

REV: 1.0 Drawing Number: 8488888x88 Page: 4 Of: 4

Date: Tuesday, February 26, 2002 Time: 6:16:44 pm

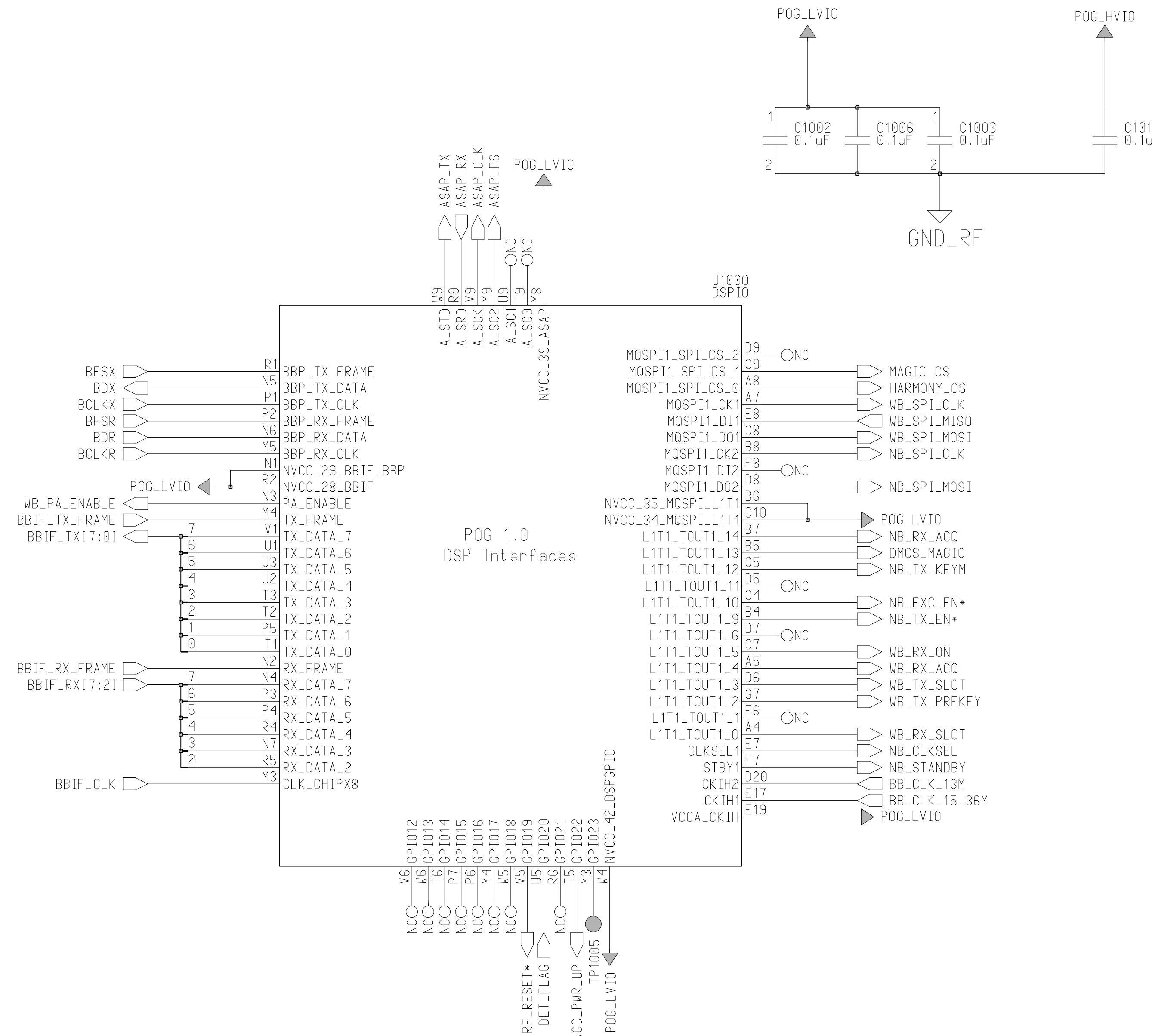

A

B

C

D

MOTOROLA CONFIDENTIAL PROPRIETARY

4 1 3 A

Engineer: Ed Naddeo			
Drawn by: Ed Naddeo			
R&D CHK:	TITLE: Talon Integrated	Size: 11x17	
DOC CTRL CHK:	POG		
MFG CTRL CHK:	Power		
QA CHK:	REV: 1	Drawing Number: 8488888x88	Page: 1
			Of: 4
Changed by: wlen01	Date: Tuesday, February 26, 2002	Time: 2:56:17 pm	

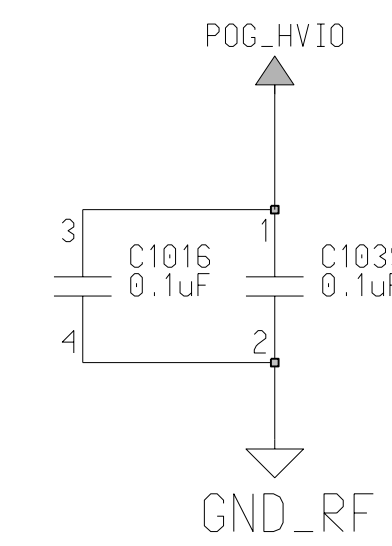
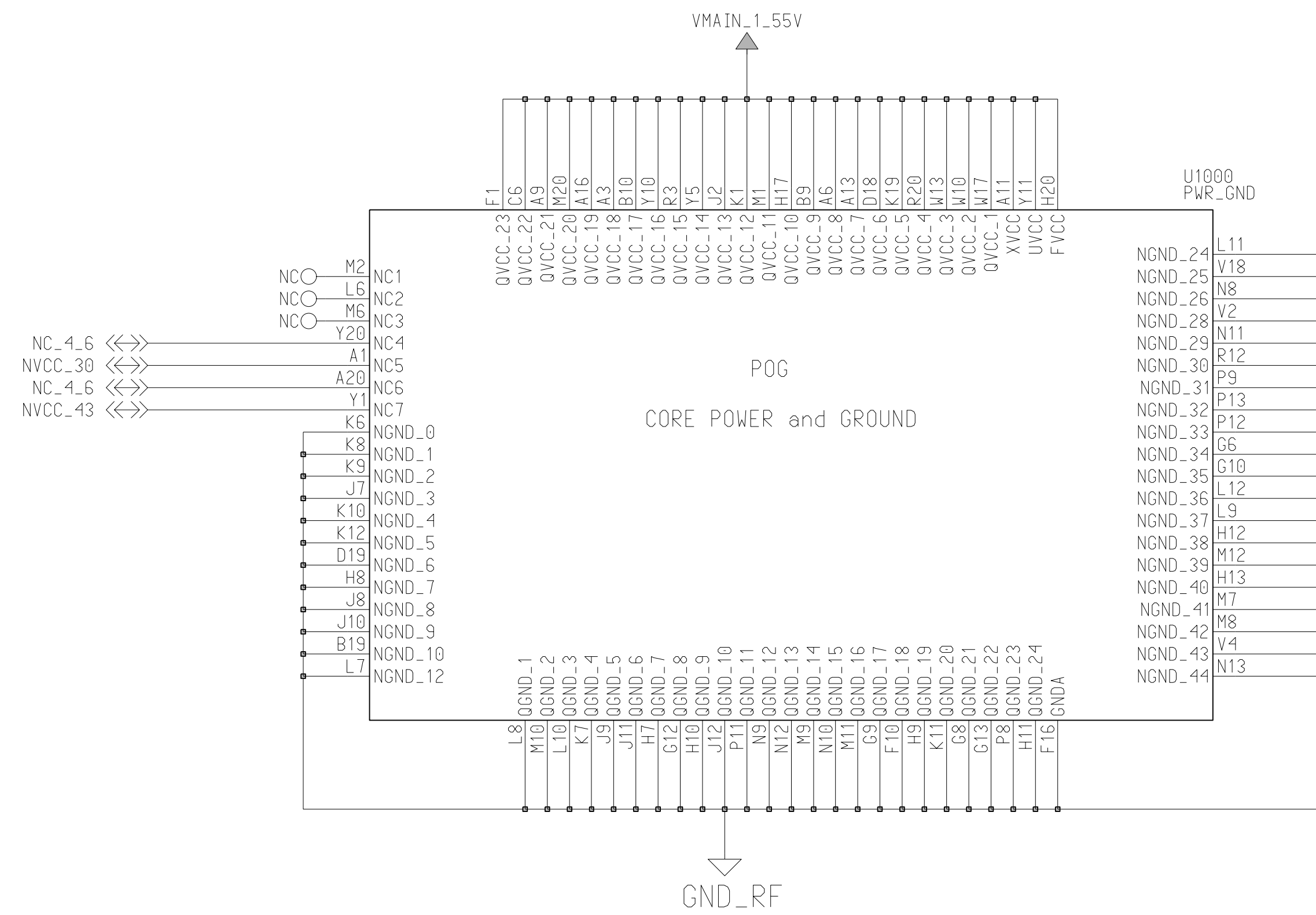
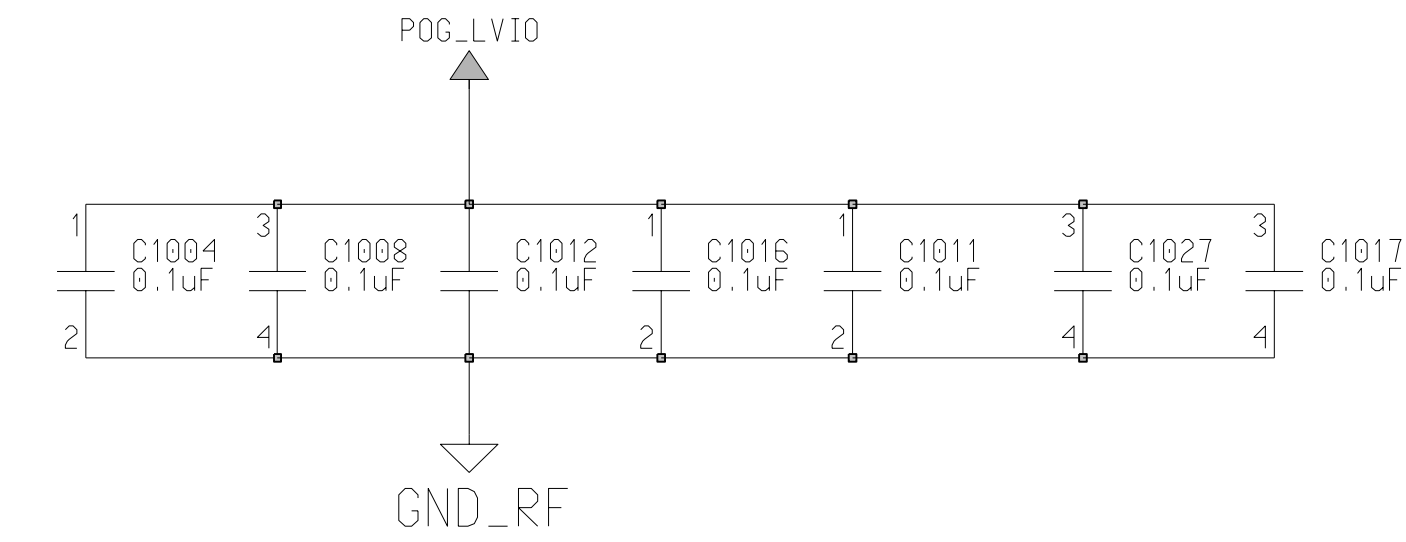
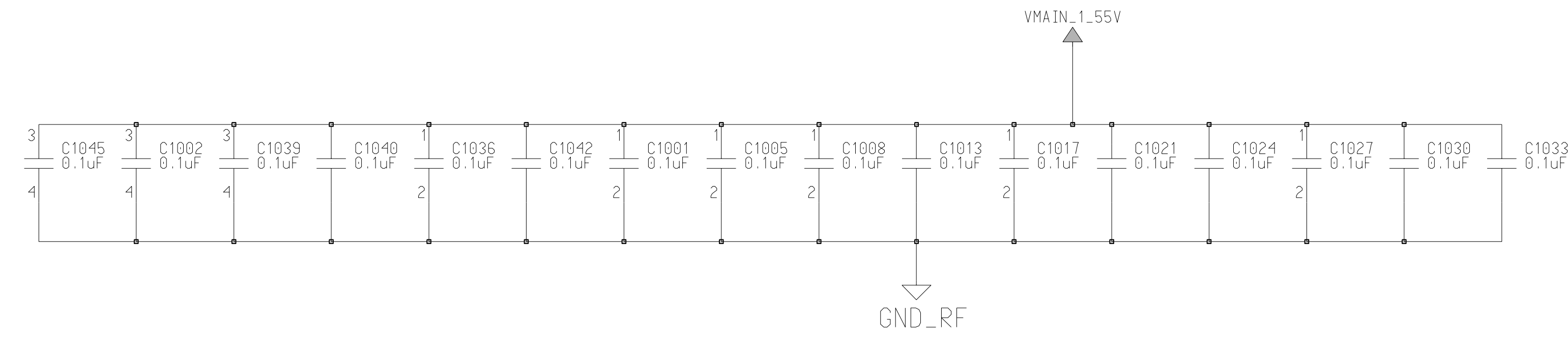

A

B

C

D

MOTOROLA INTERNAL USE ONLY

4 1 3 A



Engineer: Ed Naddeo	TITLE: Talon Integrated Flash Memory			Size: 11x21
Drawn by: Ed Naddeo				
R&D CHK:	REV: 0.1	Drawing Number:	Page: 1	OF: 1
DOC CTRL CHK:				
MFG CTRL CHK:				
QA CHK:				
Changed by: Chris Pipe	Date: Monday, May 6, 2002	Time: 9:32:29 am		

A
B
C
D

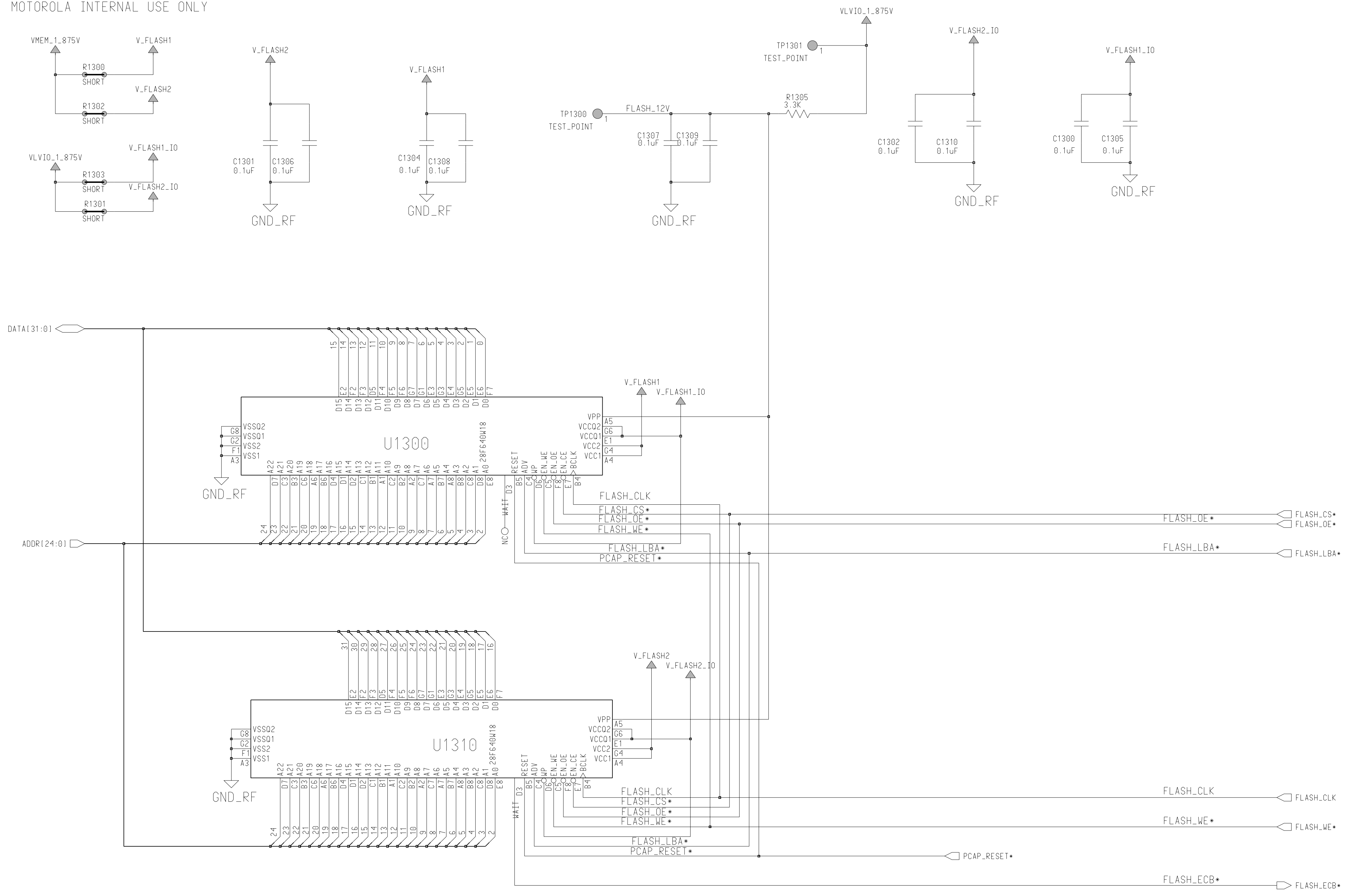

Engineer: Ed Nadeo			
Drawn by: Ed Nadeo			
R&D CHK:	TITLE: Talon Integrated 4Mx16 SDRAM	Size: 11x17	
DOC CTRL CHK:			
MFG CTRL CHK:			
QA CHK:	REV: 1.0	Drawing Number: 8488888x88	Page: 1 Of: 1
Changed by: wlen01	Date: Friday, March 1, 2002	Time: 3:37:06 pm	

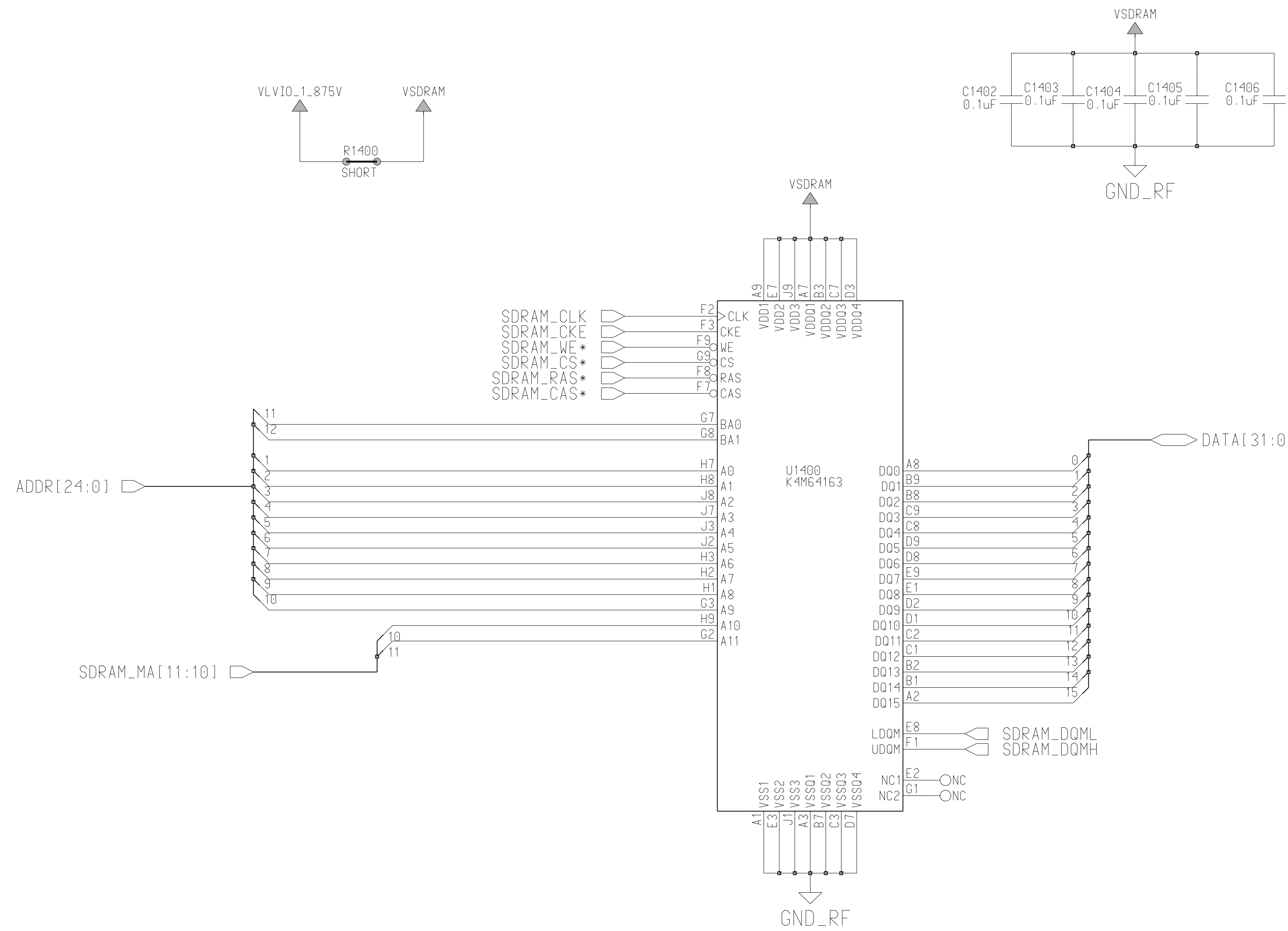

Engineer: Ed Nadeo			
Drawn by: Ed Nadeo			
R&D CHK:	TITLE: Talon Integrated Embedded SD Flash	Size: 11x17	
DOC CTRL CHK:			
MFG CTRL CHK:			
QA CHK:	REV: 1.0	Drawing Number: 84888888x88	Page: 1
Of: 1	Changed by: Chris Pipe	Date: Friday, May 3, 2002	Time: 1:25:03 pm

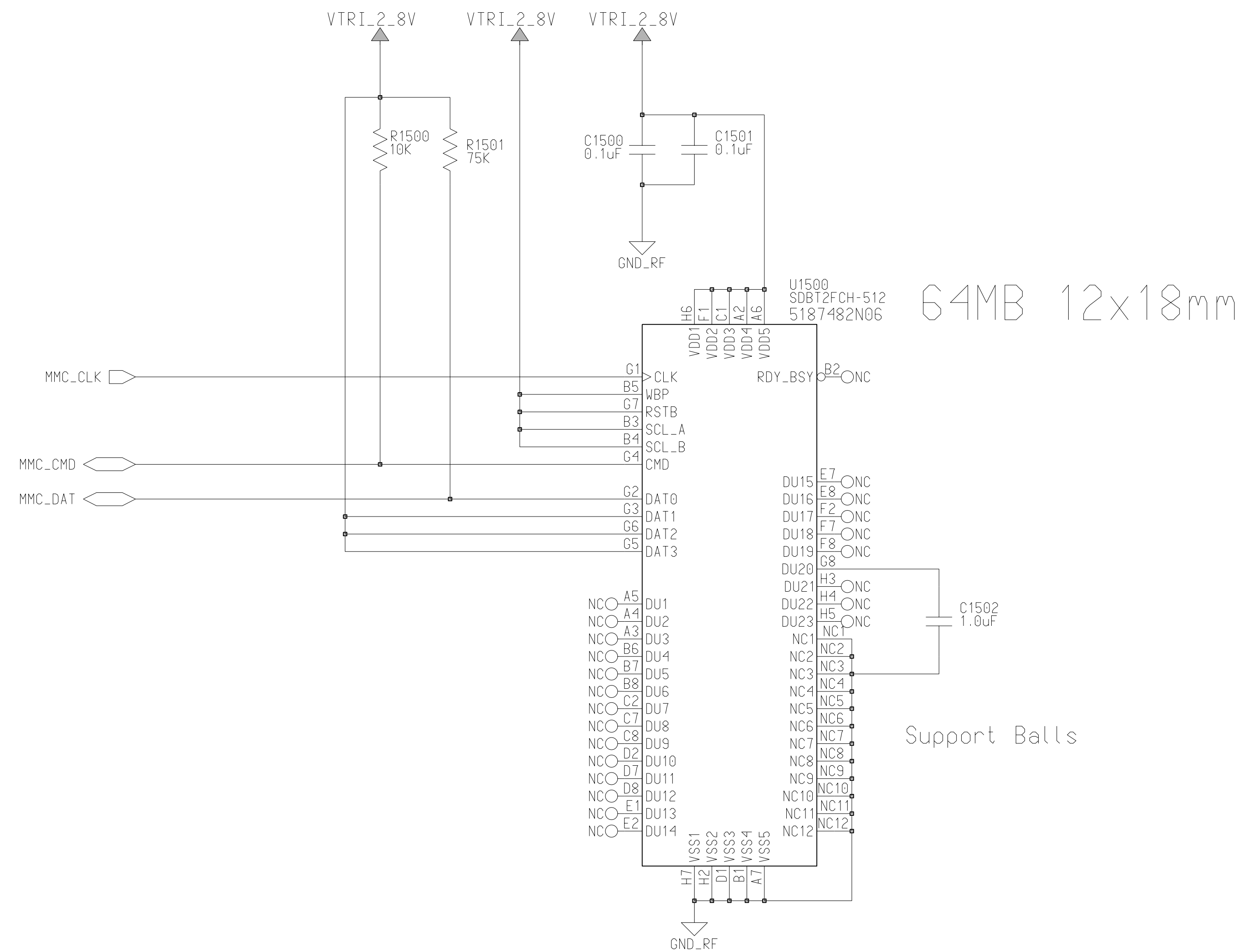

A

B

C

D

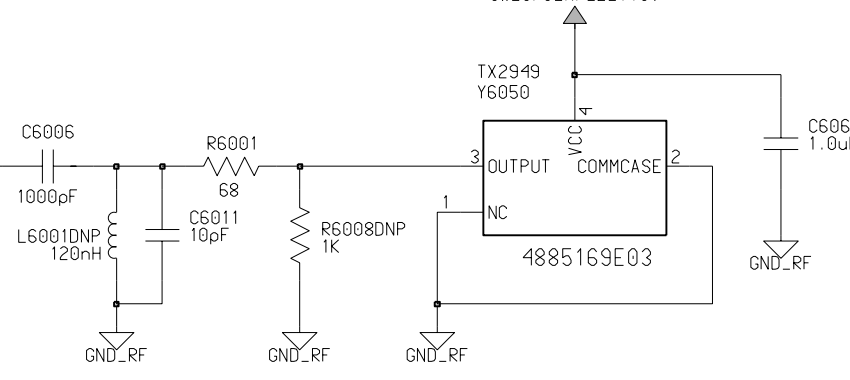
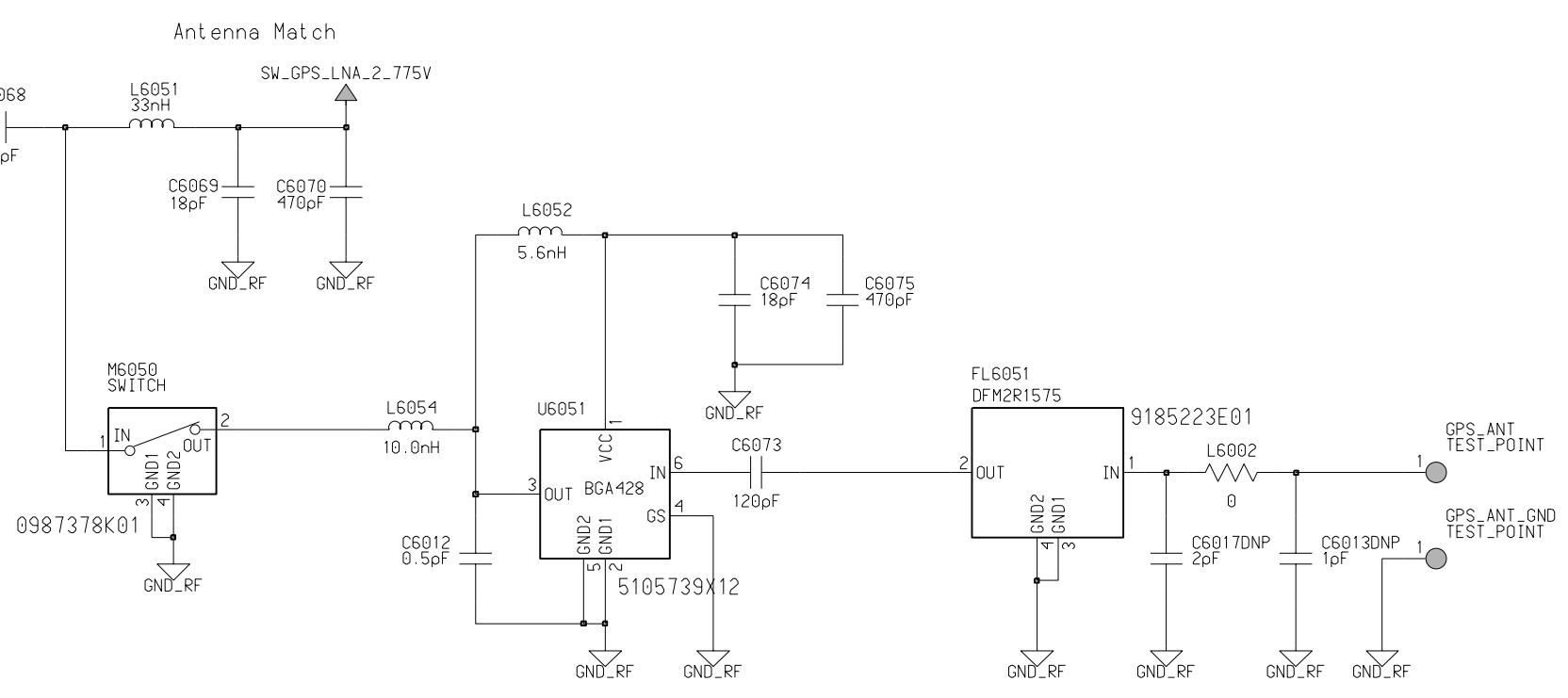
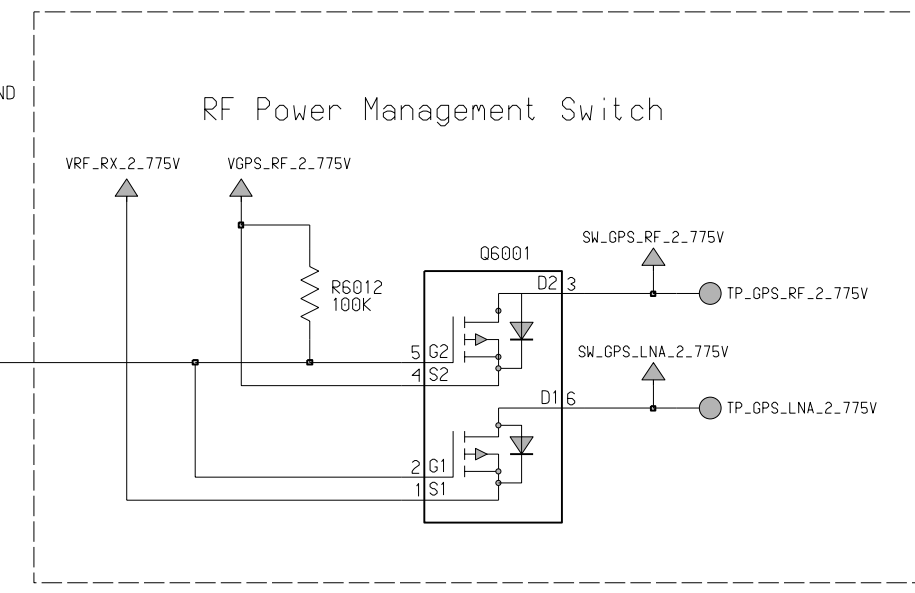
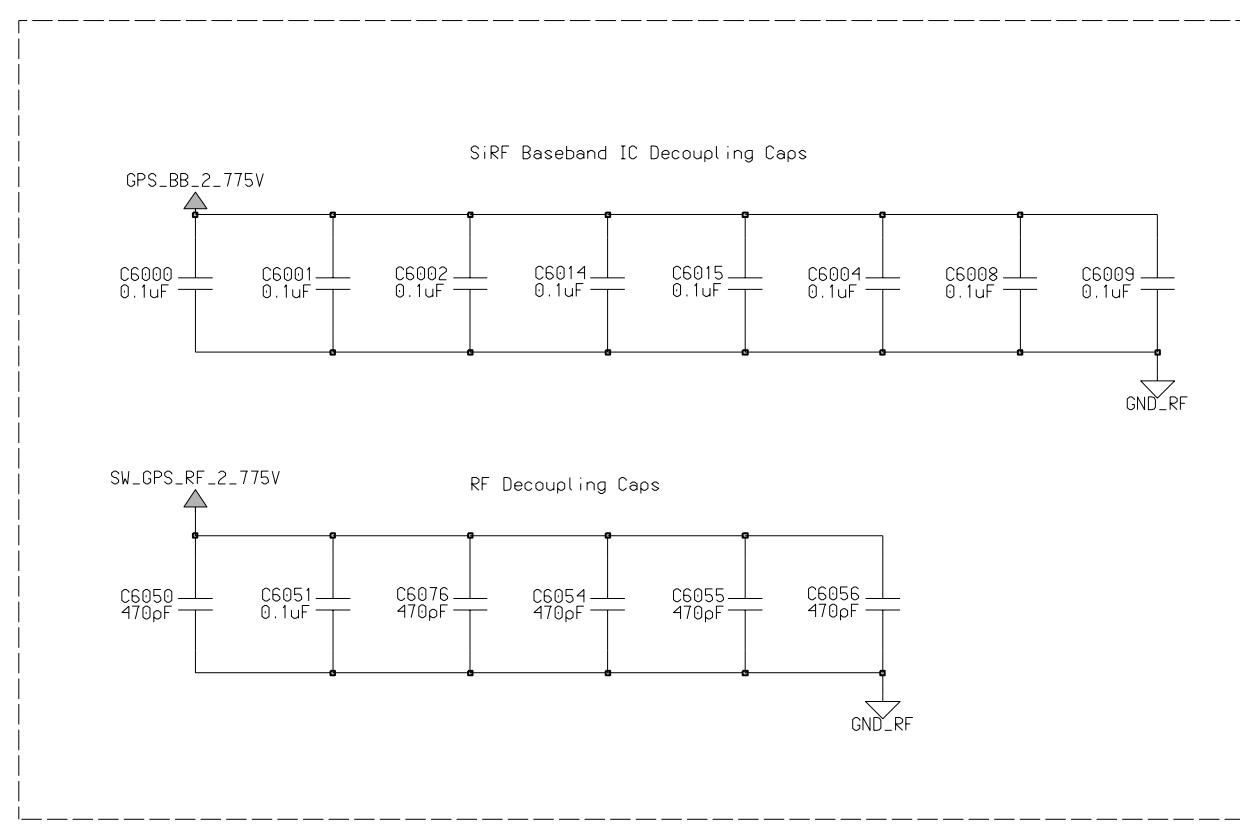
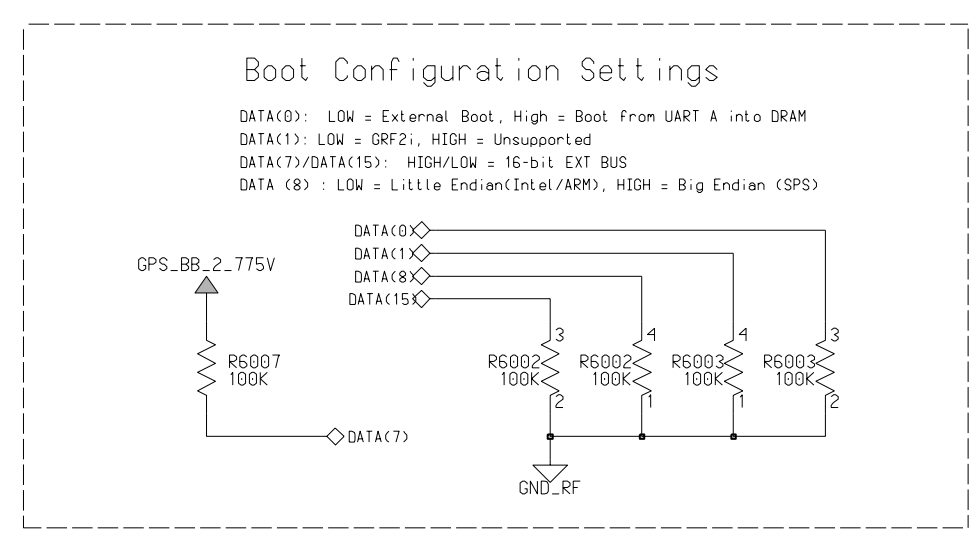
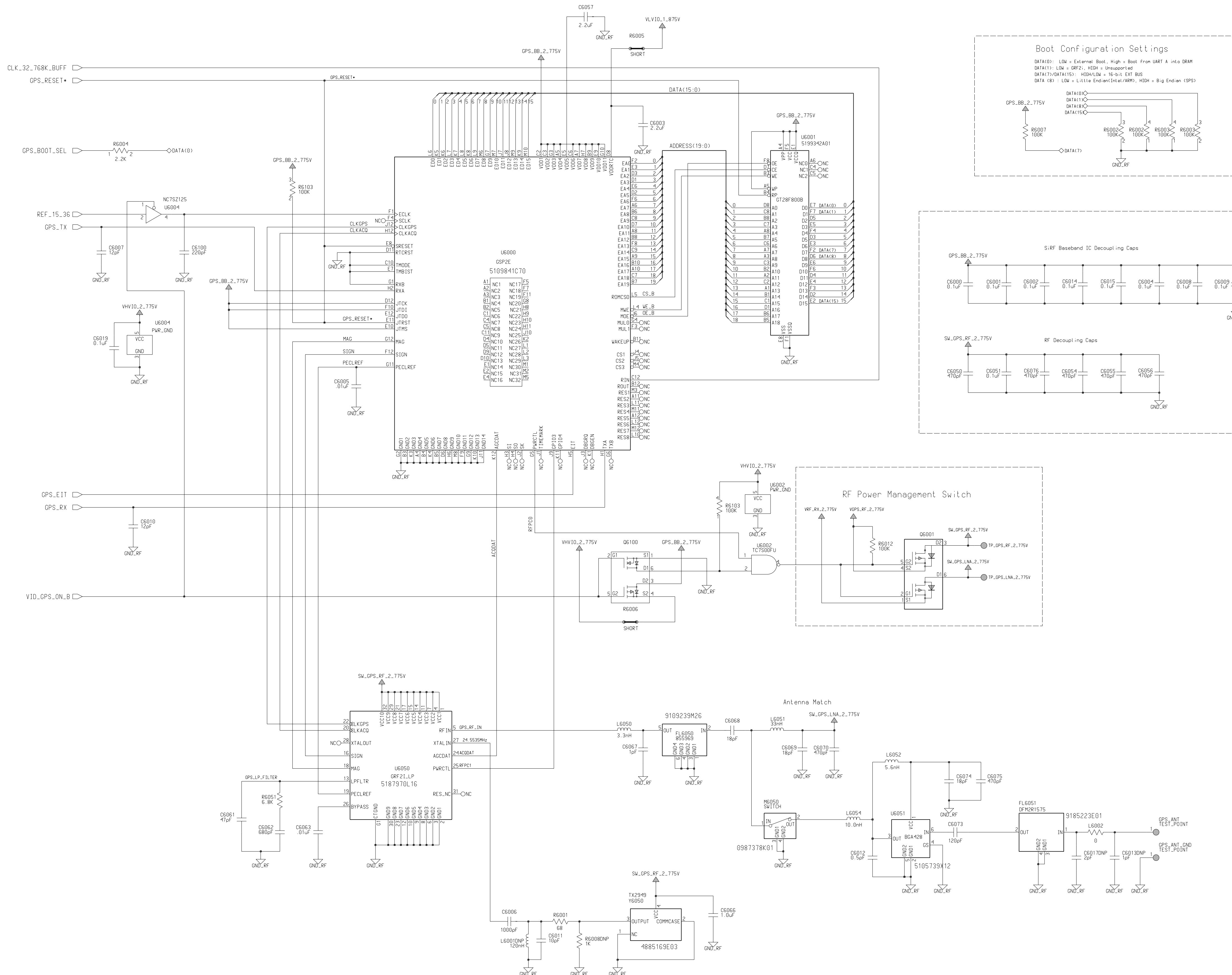

A
B
C
D
E

A
B
C
D
E

MOTOROLA CONFIDENTIAL PROPRIETARY

Engineer: Jennifer Seymour	MOTOROLA INC.	
Drawn By: Jennifer Seymour	TITLE: TALON Integrated Falcon Camera	
R&D CHK:	Size:	
DOC CTRL CHK:		
MFG CTRL CHK:		
QA CHK:	REV: Drawing Number: Page: Df:	Time:
Changed by: Jennifer Seymour	Date: Friday, November 9, 2001	10:21:35 am

A
B
C
D
E

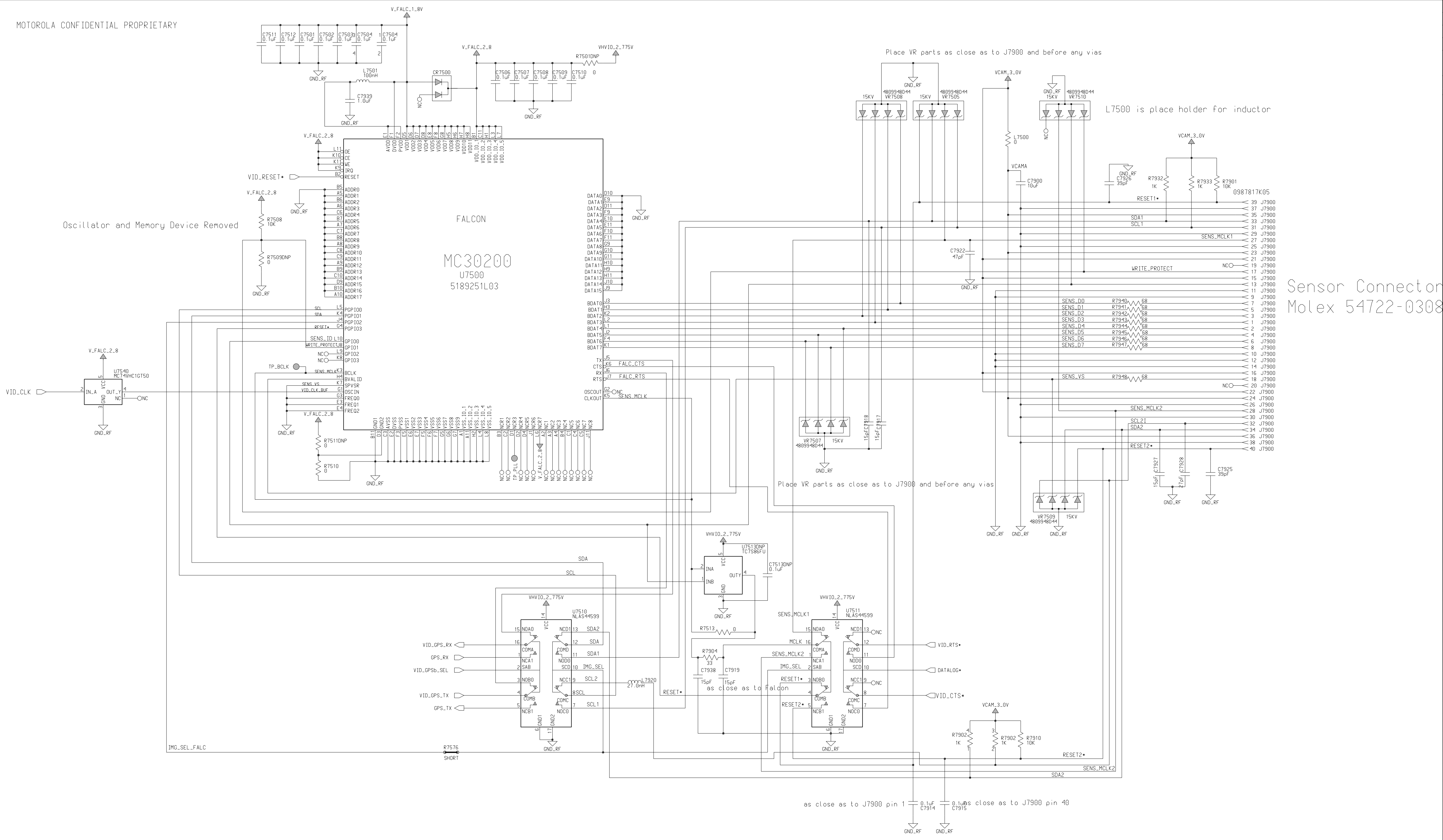

Sensor Connector
Molex 54722-0308

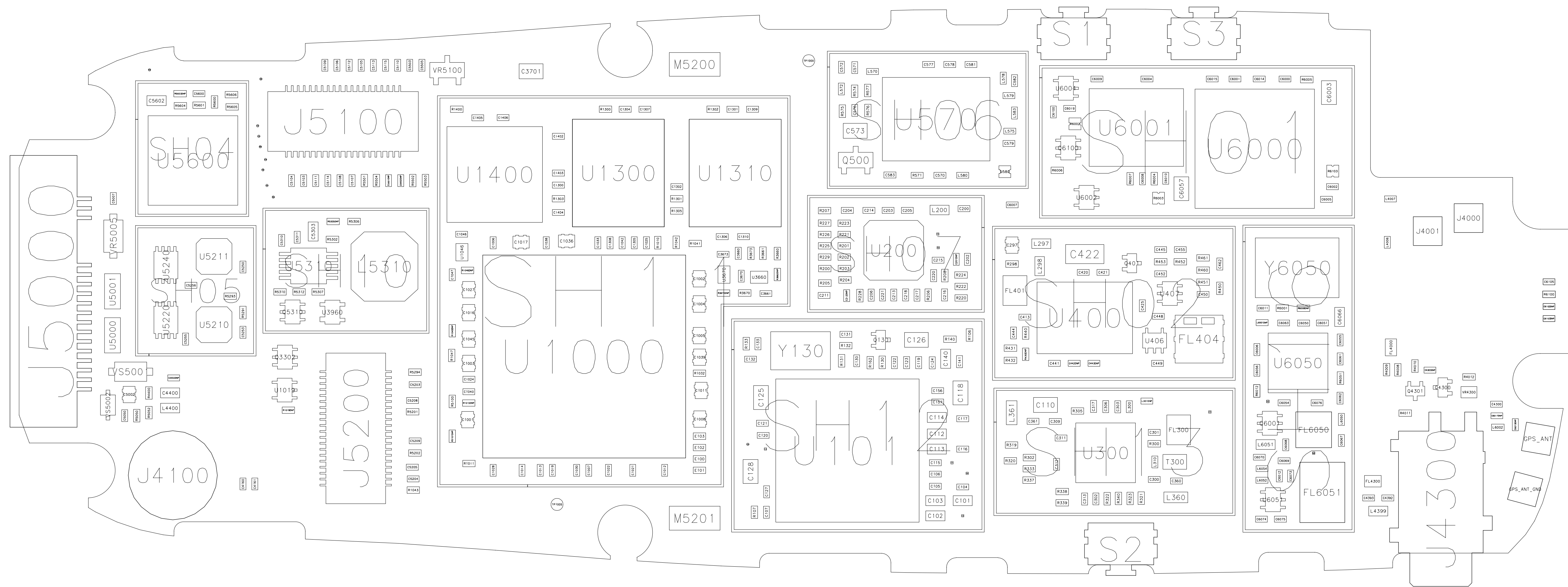

TOP SIDE PARTS

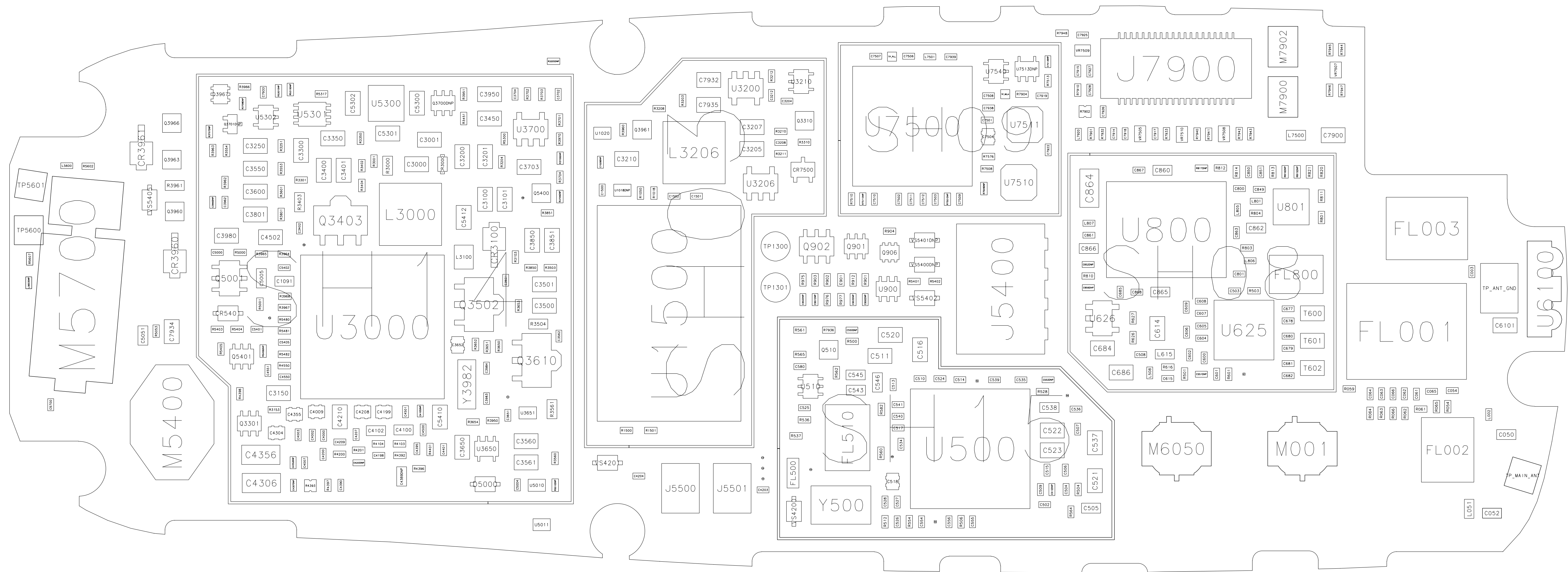

BOTTOM SIDE PARTS