

4-2 A830: Antenna Circuit

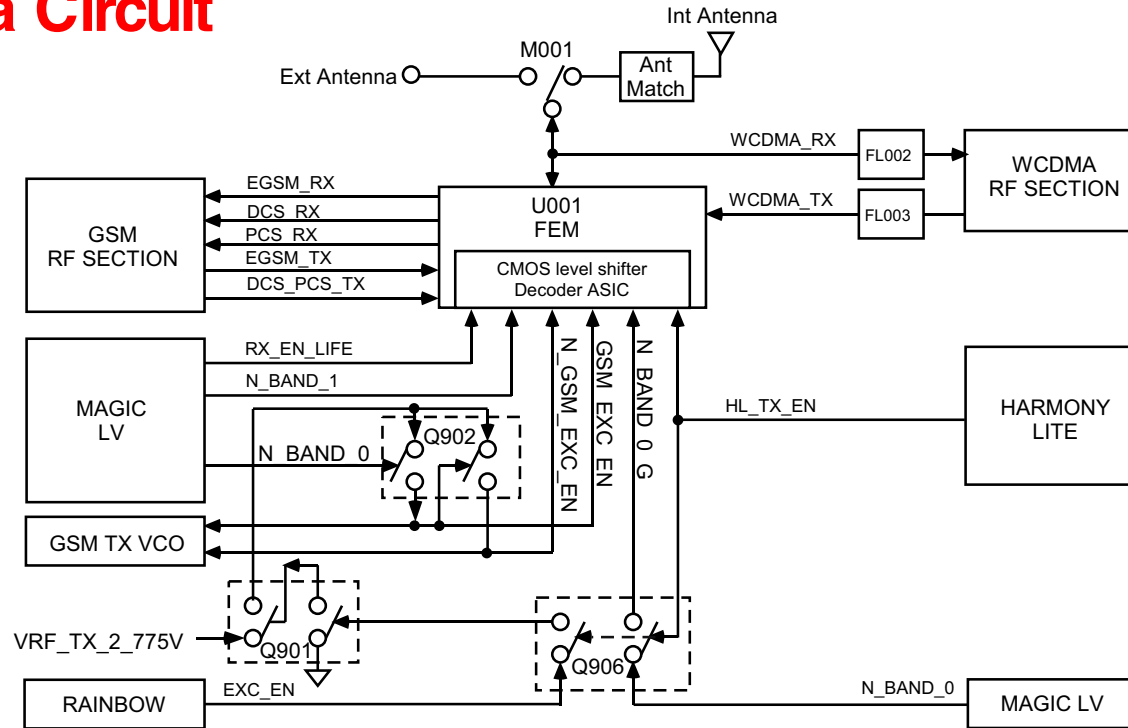

Description

All cellular receive bands are fed into either the internal antenna or external antenna. M001 is a mechanical switch which has the internal antenna path connected when a no insertion condition exists. The RF path will switch to external antenna upon insertion of a male SMA connector to M001. The internal antenna path is fed to the FEM (Front End Module) through antenna matching components. The FEM provides band selection and filtering between the EGSM, DCS, PCS and WCDMA receive and transmit bands to a single antenna port. GSM band selection is done by control lines N_BAND_1 and N_BAND_0_G. Mode selection is done by control lines HL_TX_EN, RX_EN_LIFE, N_GSM_EXC_EN, and GSM_EXC_EN. The diplexing arrangement permits reception of WCDMA signals in any FEM switch position. This allows the phone, while in a GSM call in any band, to detect signals from a WCDMA base station. The decision may then be made to hand over to the WCDMA system. Similarly, EGSM base station signals can be detected while the phone is in a WCDMA call to permit a handover decision from WCDMA to EGSM (This is not possible for base station signals in the DCS and PCS bands.).

Signals received at the antenna between 2110 - 2170MHz will see the RF switch as an open circuit at any position. Consequently WCDMA Rx signals will go through FL2 to the WCDMA receiver. FL2 should have a maximum insertion loss of ~0.5dB. Outside of the WCDMA Rx band, FL2 behaves as an open circuit, preventing out-of-band signals from reaching the WCDMA receiver.

GSM, DCS, and PCS receive signals from the antenna port through the FEM should have a maximum insertion loss of -4.4dB. The FEM EGSM transmit path should have a maximum insertion loss of -2.5dB. The FEM DCS transmit path should have a maximum insertion loss of -3.1dB. The FEM PCS transmit path should have a maximum insertion loss of -3.7dB.

Q902 is a dual FET package that's being used to multiplex function of the N_BAND_0 control signal coming from the Magic LV. With the use of Q902, N_GSM_EXC_EN will follow N_BAND_0. GSM_EXC_EN will be the inverted level of N_BAND_0. Q906 is another dual FET package that's used to prevent simultaneous GSM and WCDMA transmission conditions. During WCDMA transmission conditions, HL_TX_EN will be in a high state. This will open both FETs in Q906, thus, disabling any signal functions from control lines EXC_EN and N_BAND_0. Q901 is used to invert the control signal coming from Q906.

4-4 A830: GSM RX Front End

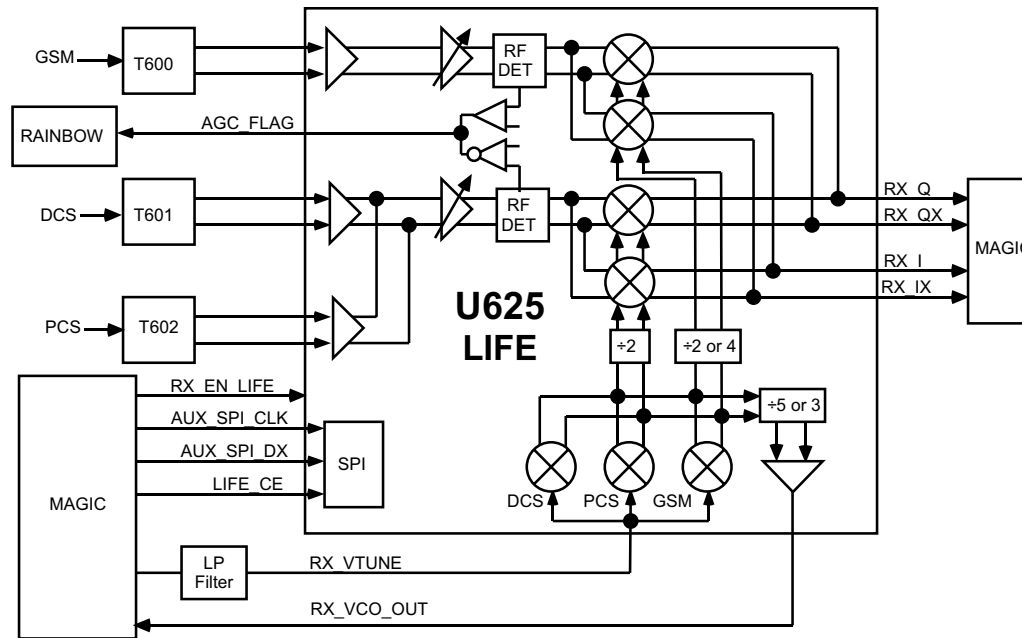

Description

The EGSM, PCS and DCS signals must first pass through baluns before reaching the LIFE IC. Since the LIFE expects differential inputs, the baluns will provide this. Baluns provide the change from an unbalanced to a balanced line condition. By directly connecting to lines together, a possibility might arise where one line might ground a signal and impair the operation of a circuit. This situation is solved through the use of an un-balanced to balanced transformer, a balun. Expected nominal losses is $\sim .5 - 1.0\text{dBm}$.

The first IC in the EGSM, DCS, and PCS RX line up is U625 (LIFE), which is an LNA, VCO, and down converter mixer. The RX frequency is mixed down to a Very Low Intermediate Frequency (VLIF) of $\sim 100\text{KHz}$. This design is utilized to improve LO leakage causing RF self-mixing, DC offsets, and noise performance. The LIFE IC operates from the MAGIC_LV (tracking regulator), MAGIC_RF_V2_475, and MAGIC_SF (isolated supply for the VCO). LIFE is comprised of four low noise amplifiers (three of which are used) with two quadrature mixer paths for use in receive GSM 900 (925- 960MHz), DCS (1805- 1880MHz), and PCS (1930-1990MHz) frequency bands, all SPI programmable. The RX_VCO_OUT signal is fed back to the MAGIC_LV prescaler input. Although the frequency will be dependent of the channel selected, the amplitude signal is $\sim 30\text{dBm}$.

LIFE contains three fully contained VCOs which operate at $\sim 4\text{GHz}$. These VCOs are internally divided to provide precise quadrature down conversion for the three frequency bands. The input signal RX_VTUNE from the RX backend processor (MAGIC_LV) selects the VCO frequency to operate at. The tune range is $.5 - 4.5\text{V}$. The VCO frequencies for the three technologies are: DCS 3610 - 35759MHz, EGSM 3700 - 3838MHz, and PCS 3859 - 3980MHz.

The AGC is provided by a common amplifier section, which is shared by all four LNAs. The AGC amplifier gain control is controlled by the voltage on the AGC pin, utilizing the internal 6-bit D/A to set the AGC via the SPI lines (SPIDATA, SPI_CLK, and SPI_CE). LIFE has an internal RF detector at the input of the AGC amplifier. The detected DC output level will be compared against a reference, which corresponds to the maximum safe input level to the mixer. This reference is SPI selectable so that the threshold can be set to 0dB, 3dB, 6dB, or 9dB below the level, which results in the mixer malfunction. If the detected level is above the reference then AGC_FLAG will go high. The MAGIC_LV will receive this signal as an interrupt and will reprogram the AGC until the level drops below the safe mixer input level as signified by AGC_FLAG returning low.

The output signals I / IX and Q / QX are @ $\sim 100\text{KHz}$ IF value for the Very Low IF. The input pin, RX_EN_LIFE controls the on / off state of the receiver and the PLL circuits. For input amplitude at the antenna of -50 to -40dBm the expected nominal output should be an AC rms peak-to-peak voltage of $\sim 4.5 - 14\text{mV}$.

4-6 A830: GSM RX Back End (Magic LV)

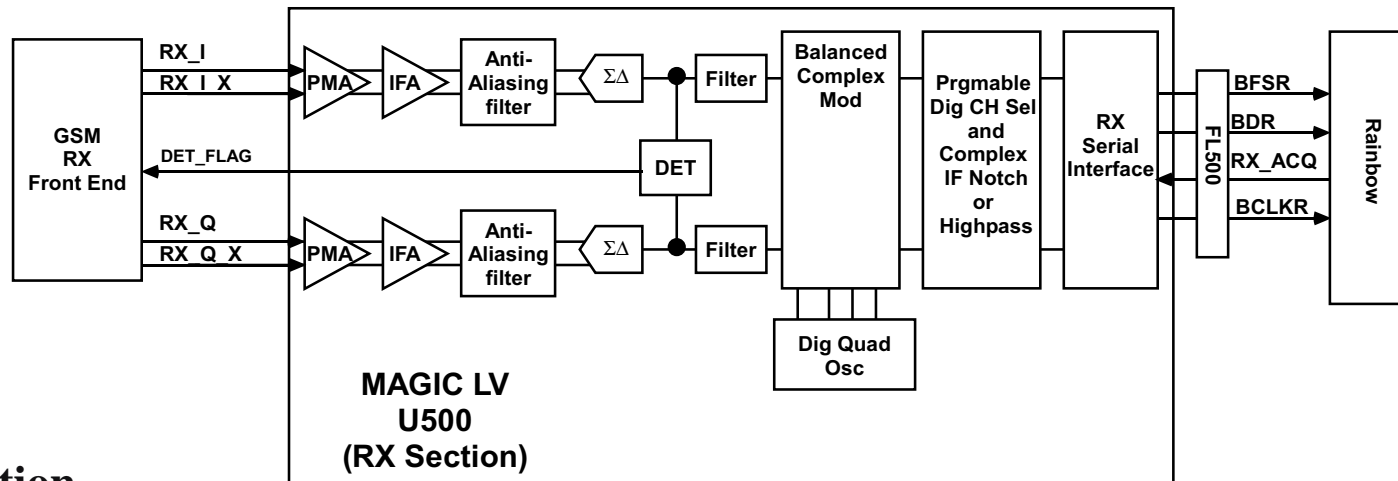

Description

The MAGIC_LV (U500) handles the backend processing for the EGSM, DCS and PCS (VLIF: RX_I, RX_I_X, RX_Q, and RX_Q_X) signal lines from LIFE. Simply, the MAGIC_LV performs an analog to digital conversion of I/Q and sends it to the data to the board processor (RAINBOW) via the SSI (serial synchronous interface). The MAGIC_LV also has a programmable and phase-able digital IF to improve image rejection.

In MAGICLV, each channel is comprised of a Post Mixer Amplifier (PMA), an integrated passive two pole filter, a gain stage (AMP1) followed by an active programmable 2 pole anti-aliasing filter (mainly required to meet the blocking specs). This is followed by a lowpass sigma-delta ADC with a programmable oversampling clock OVCLK (derived from the reference oscillator) equal to 13MHz for 200kHz channel spacing (13bits).

Digital detector circuits are placed on each channel at the output of the sigma delta converters. The outputs of these detectors are compared against a level defined by DET_LVL. If either of the detected levels exceeds the programmed threshold then the pin DET_FLAG is set high. This indicates that the signal level is excessively high for the sigma delta modulator. DET_FLAG is read by the processor, which will respond by re-programming one of the AGC settings to a lower gain until DET_FLAG returns low.

The outputs of the sigma-delta modulators are digitally processed through a noise cancellation circuit, comb and decimation filters. A second programmable digital LO based on a look up ROM generates digital quadrature oscillators with programmable gain/phase correction (called balanced complex multiplier) to digitally downconvert the I/Q signals to baseband (digital zero IF) through four quadrature mixers that provide image rejection of adjacent/alternate channels. Gain/ Phase correction at a single baseband frequency is performed on the Digital Quadrature Oscillator to compensate the analog gain/phase mismatch of the quadrature I and Q paths. After baseband downconversion and image reduction, the quadrature I and Q signals are further processed by digital filters that perform channel selectivity and out of band noise rejection.

A serial bus consisting of SDFS and SDRX will transmit the RXI and RXQ data in 2's complement format. BDR and BFSR are outputs from MAGIC LV. BFSR is a framing signal which marks the beginning of an I,Q transfer. BDR is the serial data. The clock used for the serial transfer is BCLKR. When RX_ACQ goes high MAGIC LV will activate the SSI interface in the digital receiver section. The data transmission over the serial bus will begin at the next normal occurrence of valid I and Q data, as defined internally to the digital receiver.

4-8 A830: MAGIC LV Control Functions

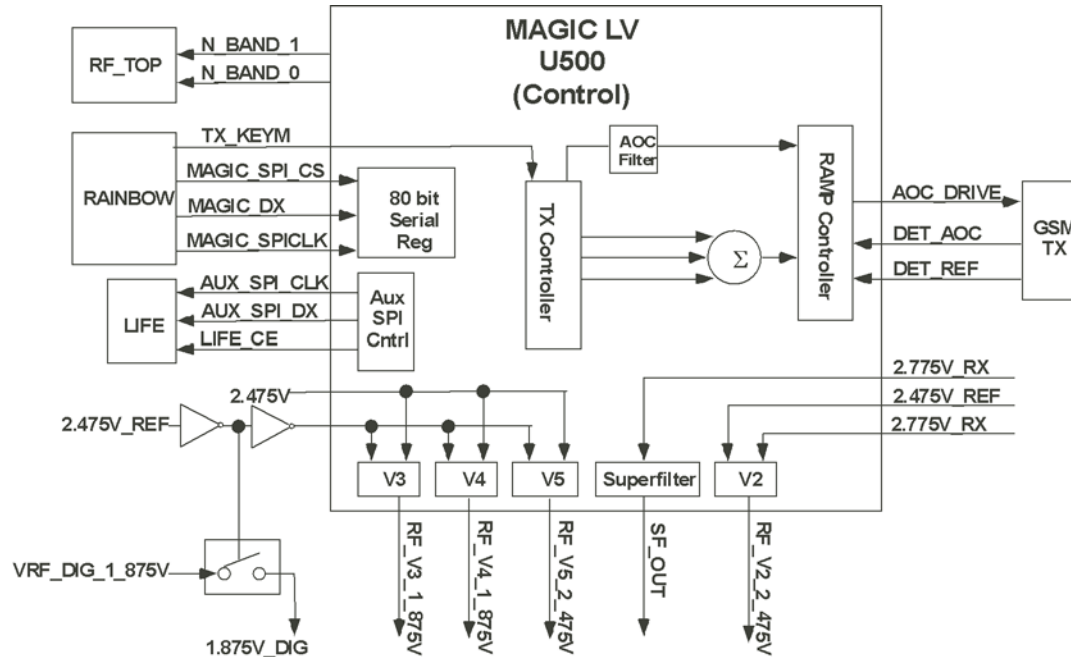

Description

The MAGIC LV contains 4 tracking regulators and one superfilter, which will generate the supplies for most of the IC as well as the front end and the main VCO. The tracking regulators derive their internal power from the REG_REF pins. The reference voltages are filtered and buffered for use on the IC. The buffered voltages should track the references within +/-1.5%. A raw supply voltage is provided to the tracking regulators which is higher than REG_REF as specified below for each regulator. A superfilter is needed for the external VCO power supply. This superfilter, cascaded with an external regulator and any filtering in front of the IC, will need to provide 80dB of rejection to a 0.1V step occurring at a 217Hz rate with a risetime of 20us on the raw supply (battery) and a duty cycle of 0.125. The superfilter will use an internal pass transistor that is capable of driving a 30 mA load with a voltage drop of less than 0.4V relative to SF_SPLY from the SF_OUT pin. An external 1uf cap is required on SF_OUT. As the superfilter will track SF_SPLY it will need to sense the power on reset and turn off even though its supply may remain active. All supplies within the IC must be within 5% of their final values after 5msec from the start of POR_LB. The power on reset circuit contained within the crystal reference oscillator is used to aid this functionality.

The MAGIC_LV has two sets of SPI interfaces; one set is for handling the control interface for the LIFE IC (AUXSPI lines) and ones for interfacing with RAINBOW (SPI lines). AUX_SPI_DX is the serial data input line. AUX_SPI_CLK is the clock input line, where data shifting occurs at the rising edge of this signal. LIFE_CE is the clock enable line, active high, for the LIFE IC.

MAGIC_LV will integrate a system of D/As and control logic to generate the power amplifier control ramps. In addition, MAGIC_LV will integrate the op-amps and comparators which receive the detected output of the power amplifier and create the necessary control voltage to drive the power amplifier control port based on the control ramps. When TX_KEYM goes high, the ramp controller receives an positive input. This will cause the AOC_DRIVE pin to linearly rise which in turn will cause the PA output power to rise. The rising PA output power will cause DET_AOC to begin to rise until the DC level on DET_AOC exceeds the DC level on DET_REF by the intentional offset of the RF detector versus it's reference. At this point the "Active Detect" comparator will go low and break the input voltage to the integrator with the ramp controller. This will cause the PA power to stop rising and hold the present power level as determined by the 8 bit offset value fed to the ramp controller. The PA control loop is now at a minimal power needed to keep the control system in a closed loop for a controlled ramp up of the power.

The MAGIC uses two SPI driven GPO lines which are used to control the operating bands of the GSM RF circuits. They are N_BAND_0 and N_BAND_1.

When the MAGIC LV is set to battery save mode it will shutdown the receiver analog sections (via RX_EN_LIFE), the AOC, the main synthesizer and the superfilter.

4-12 A830: GSM TX VCO

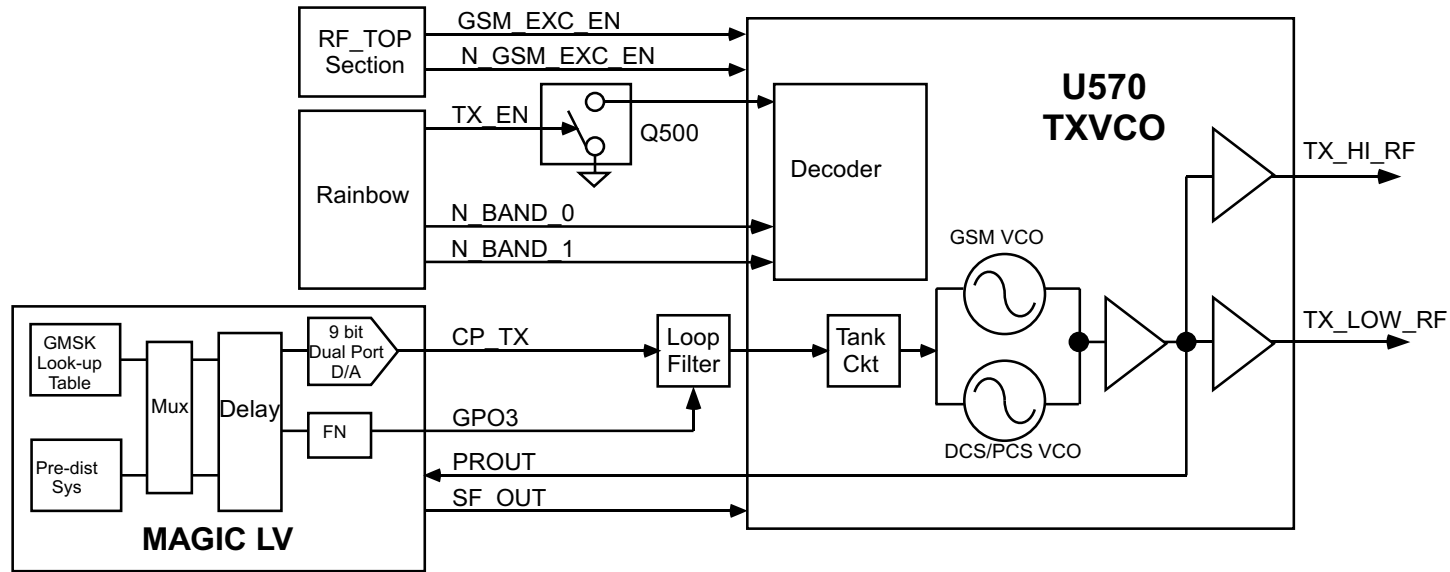

Description

The VCO frequencies are 897 - 1880MHz, handling the three technology bands. The technology bands are controlled by MAGIC_LV via the data lines: N_BAND_0 and N_BAND_1. CP_TX and GPO3 provides a dual port modulation mode for the TXVCO. N_BAND_0 and N_BAND_1 will select which VCO band will be activated. GSM_EXC_EN and N_GSM_EXC_EN will enable the buffer stage of U570. TX_EN is activated prior to enabling the buffer and PA. PROUT is fed back to the MAGICLV for proper PLL operation. The output frequency for GSM is TX_LOW_RF and PCS / DCS is TX_LOW_RF. The charge pump output (CPTX) from MAGIC_LV is the input (VT) for the VCO.

4-14 A830: GSM PA

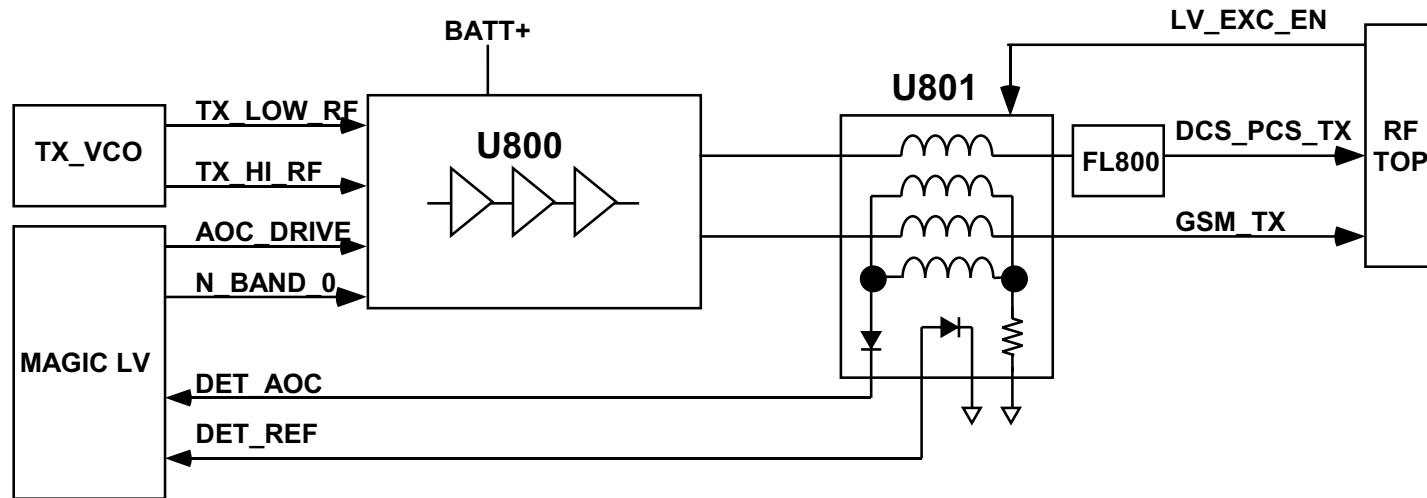

Description

U800 is a tri-band PA module that operates in EGSM, DCS and PCS bands. The nominal expected maximum gain is ~30dB. .

The AOC_DRIVE input from MAGIC_LV controls the PA output. The voltage applied at the pin is proportionally related to the output power of the PA, as the voltage increases the gain or power level increases. N_BAND_0 is used to select the operating band. LV_EXC_EN will enable PA operation.

The power detector receives the amplified GSM signal at #1 (EGSM_IN), PCS and DCS at pin #12 (DCS_PCS_IN) from the U800. U801 is a dual combination directional coupler and temperature compensated power detector output. The power detector couples the Tx power input and feedbacks an output DET_AOC to MAGIC_LV. A comparator within the MAGIC LV will sample DET_AOC and based on the power amplifier ramps will provide any necessary control voltage adjustments to AOC_DRIVE. The DET_REF is a reference voltage to MAGIC_LV. Expected nominal loss is <. 3dB.

4-16 A830: WCDMA RX Downconverter (MAX2388)

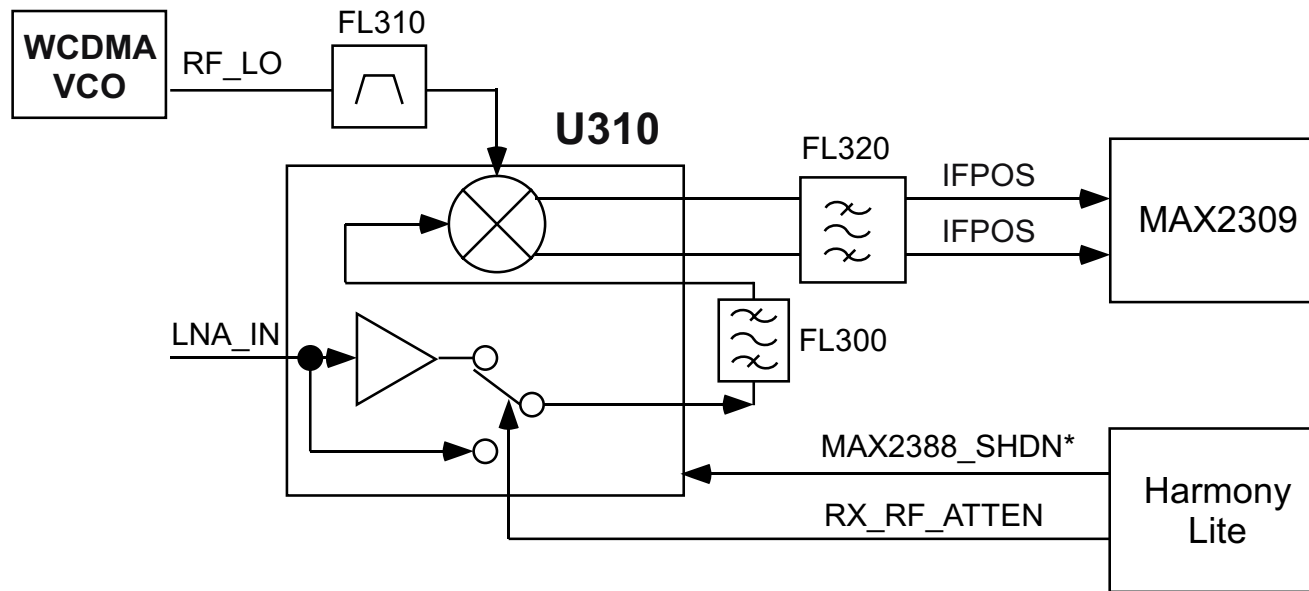

Description

The first IC in the WCDMA Rx line up is U310 (MAX2388), which is an LNA and down converter mixer combination. The RX frequency will be mixed down to an IF frequency of 190MHz. The MAX2388 also has a shutdown mode to power down the IC, via MAX2388_SHDN*, during the front-end receiver's idling period to conserve battery life. U310 operates from the PCAP supply voltage RC_VCCA (derived from VRF_RX_2_775V). The nominal gain expect is ~15dB.

U310 operates in high gain mode selectable from RX_RF_ATTEN by the HARMONY_LITE . The nominal gain expected while in this mode is 15dB. During high input signal levels the LNA will be off.

The receive mixer is a wideband, single-balanced design. The input RF_LO (pin #5) receives the VCO frequency (2330 - 2360MHz) through FL310 from U140 (VCO). The RF input (LNA_IN, pin #10) receives the RX frequency (2110 - 2170MHz) from FL002.

The MIX_IN (pin #3) input is connected to LNAOUT (pin #1) through FL300. The function of FL300 is to provide image rejection and out-of-band interferers filtering. The frequency conversion process performed by the mixer / oscillator combination sometimes will allow a frequency other than desired frequency to be fed into the IF and subsequently amplified.

The IF mixer output (190MHz) appears on the differential IFPOS (pin #8) and IFNEG (pin #7). These open-collector outputs require an external inductor (L320 & L321) to VCC for DC biasing.

The 190MHz IF frequency passes through FL320. The IF SAW filter has a nominal center frequency of 190MHz and a bandwidth of 3.84MHz. Between the input match (C323, C324 & L322), output match (L327, L328, C328, C329, & C325) and the filter (FL320)- the expected nominal losses is ~10dB.

4-18 A830: WCDMA RX Demodulator (MAX2309)

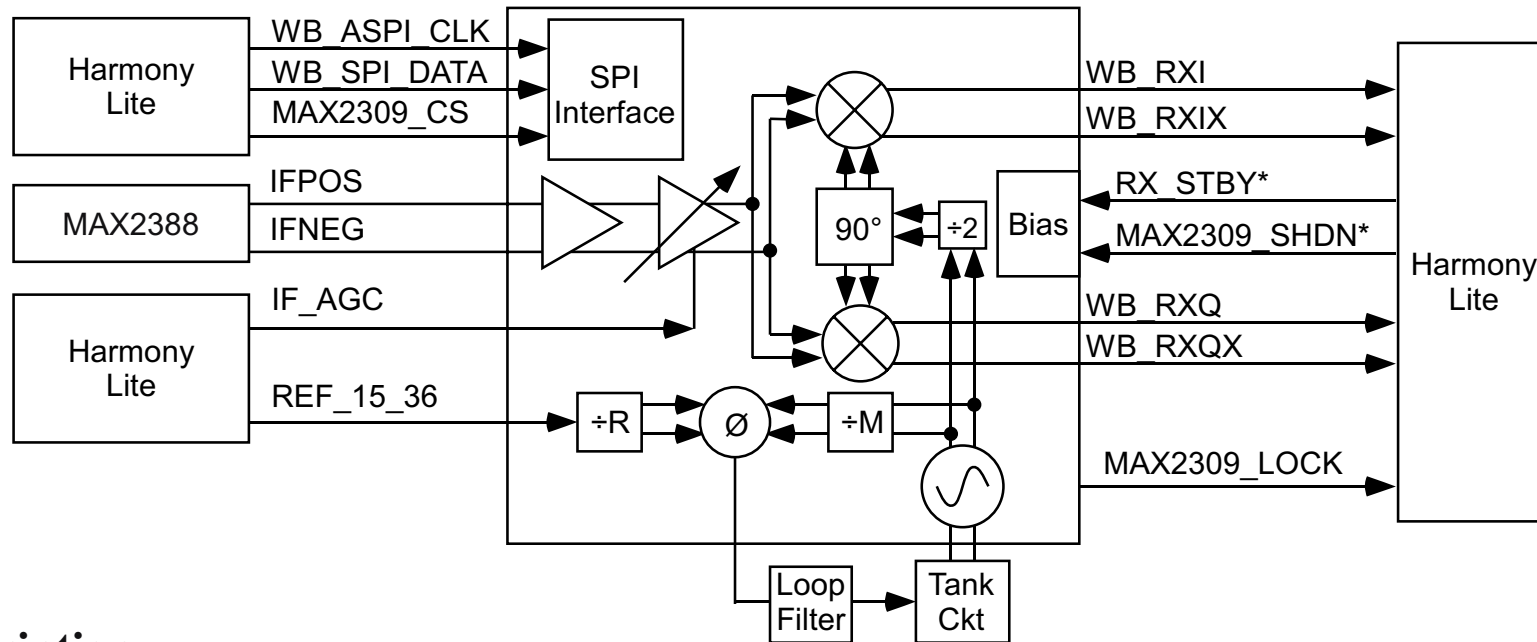

Description

The MAX2309 is an IF quadrature demodulator with the signal paths consisting of a variable-gain amplifier (VGA) and an I/Q demodulator. The IF LO synthesizer's reference and RF dividers are fully programmable through the 3-wire serial bus (WB_ASPI_CLK, WB_SPI_DATA, MAX2309_CS). The 190MHz IF is demodulated to BaseBand differential in phase (I+ / I-) and quadrature (Q+ / Q-) signals to be passed through to the receiver's backend IC, HARMONY LITE. The IC operates from a pair of supply voltages RX_VCCD & RX_VCCA derived from VRF_RX_2_775V.

The MAX2309 VCO output frequency is controlled by an internal phase lock loop (PLL) synthesizer. The external loop filter consists of the components connected to pins #1 and #2 (& pin #26). The VCO output frequency (Tank+ / Tank-) at pins #1 and pin #2 are divided down internally, to a desired comparison frequency. The reference signal at pin #7 (REF_15.36MHz) is also divided down to the same comparison frequency. The two divided signals are compared with a three state digital phase detector. The internal phase detector drives the charge pump as well as the lock-detect logic. The charge pump output at pin #26 (CP_OUT) is processed by the external loop filter and drives the tunable resonant network, altering the VCO frequency (380MHz) and closing the loop.

The AGC ensures that the I/Q inputs to HARMONY LITE are at constant signal level. The IF_AGC line is controlled by HARMONY_LITE with a DC control range of 1.2V to 2.1V.

The MAX2309 has a shutdown mode to power down the IC, via MAX2309_SHDN*, during the front-end receiver's idling period to conserve battery life. RX_STBY* is used to shut down VGA and demodulator while maintaining the VCO, PLL, and serial interface active.

4-20 A830: Harmony Lite (Receive Section)

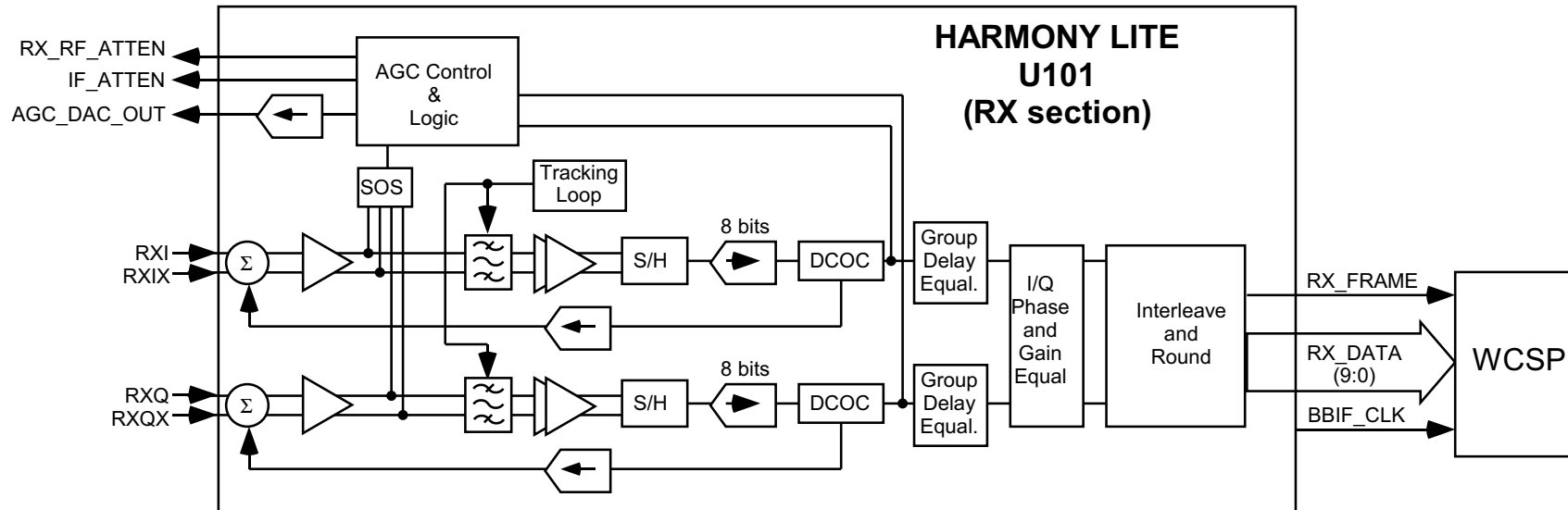

Description

The HARMONY LITE (U101) handles the backend processing of the WCDMA in phase (WB_RXI, WB_RXIX) and quadrature (WB_RXQ, WB_RXQX) signals from the demodulator. The HARMONY LITE performs an analog to digital conversion of gain, phase and DC offset correction of the RX data and sends it to the WCSP (U7000) via data lines RX_DATA(9:0).

The analog I and Q signals are applied to the Harmony Lite IC, which processes the analog baseband portion of the radio. The SOS detector is used as an off-channel detector to detect the level of undesired interfering signals. It monitors the voltage swing at the input to the baseband filters, and provides a logic level output to the AGC/RSSI controller to indicate if the level is greater than a threshold specified by SPI bits, which then sets the appropriate gain setting in the front-end and IF stages. The AGC system provides overload protection for both the strong on-channel signal and the off-channel portion of the signal (interferers) that is present in the RF receive band. Signal levels are detected at the baseband filter inputs of the Harmony Lite (off-channel detector) as well as after the channel filtering and analog-to-digital conversion (on-channel detector). The digital AGC/RSSI block controls the bypass mode of the LNA and the IF variable gain amplifier. A digital representation of the desired received signal strength is sent to the Rainbow via the SPI.

Low pass filtering is performed on the complex I and Q signals, and then applied to the associated 8-bit ADCs and sampled at a rate of 4 times per symbol. A DC offset correction loop corrects for any DC offsets at the I and Q ADC inputs. A group delay equalizer is employed in the receive signal path following the baseband SRRC filter to minimize performance loss from the analog active order SRRC channel filter. Gain and phase mismatches between the I and Q channels can affect the detectability of a WCDMA signal in static and multipath fading conditions due to distortion caused in the QPSK signal constellation map. Thus, I/Q magnitude and phase imbalance correction circuits are used. At the output of the Magnitude Equalizer, the I and Q values are rounded from 8 bits to 6 bits and then multiplexed and routed to the digital signal processing circuitry located on the Rainbow IC.

4-22 A830: Harmony Lite (Control Section)

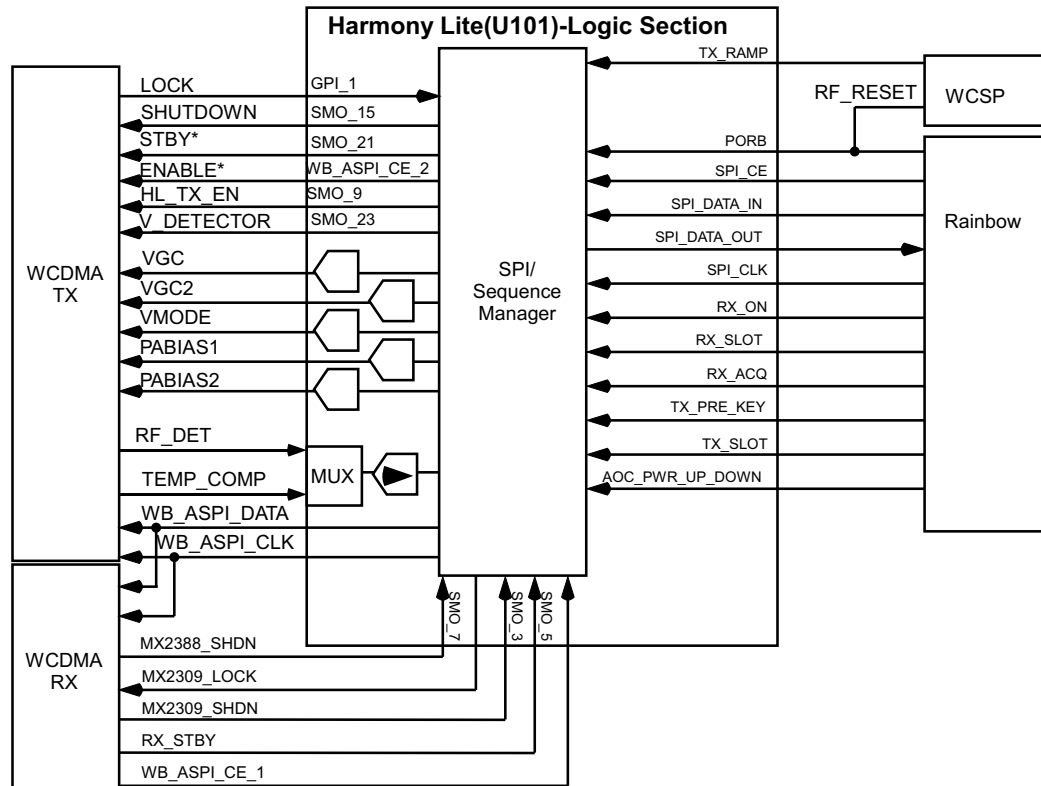

Description

There are several functions that the sequence manager is controlling.

1. Sequence manager outputs to external devices
2. On/Off control of clocks, battery save signals etc...
3. Clock frequency selection for correction paths
4. DCOC register selection coarse, medium and fine modes

The HARMONY LITE has two sets of SPI interfaces; one set is for handling the control interface for the transceiver (AUXSPI lines) and ones for interfacing with RAINBOW (SPI lines). Further, all SPI interface is generated from RAINBOW and written to HARMONY_LITE or parsed through to the MAXIM (U200 & U310) parts.

Layer one timing signals control the functionality of the RF section of the transceiver relative to the air interface. There are three signals defined on each transmit and receive section of the transceiver. TX_PRE_KEY and RX_ON are asserted before the need to receive or transmit in order to launch the necessary sequence of events to warm up the required functional blocks. TX_RAMP and RX_AQUIRE are asserted when actual transmission and reception are to begin. RX_SLOT and TX_SLOT are used during continuous transmission and reception to trigger events that must be aligned with slot boundaries. It's important to reiterate, the TX_RAMP directly corresponds to the PA turning on and RX_AQUIRE corresponds to data being sent to the WCSP.

4-24 A830: Harmony Lite (Synthesizer Section)

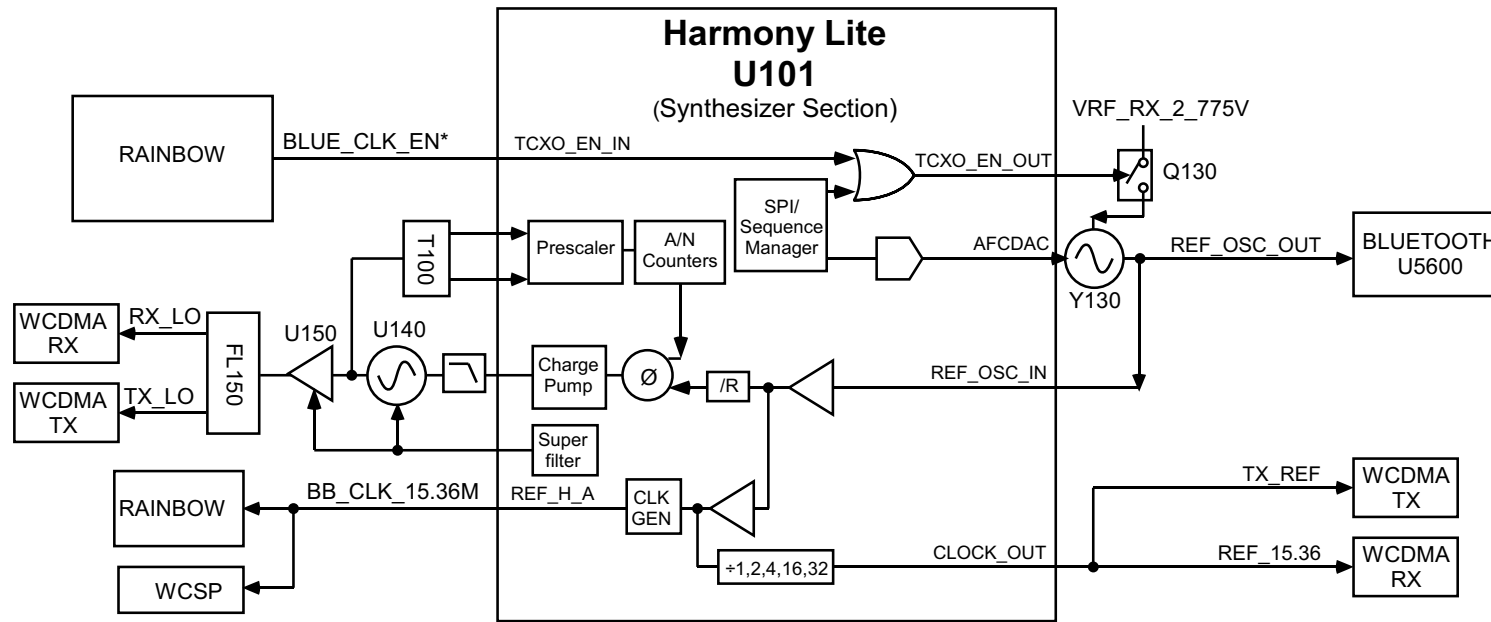

Description

The clock source for the Harmony Lite (HLite) is a 15.36Mhz oscillator (TCXO). Y130 is used to generated the 15.36MHz clock source. AFC for Y130 is controlled by the Harmony Lite sequence manager via the AFCDAC line. The 15.36MHz clock source is enabled by an internal SPI bit and external control signal coming from RAINBOW(BLUE_CLK_EN*). The 15.36MHz clock source provides clocks to all A/Ds, DACs, external references and internal digital circuits of the Harmony Lite. In addition, clock references are generated for the RAINBOW, WCSP, RX and TX RF circuits.

The WCDMA VCO(U140) has a frequency range of 2.3G thru 2.36GHz, supplying both the receiver and transmitter with an LO. The control range is controlled by HARMONY_LITE with a control range between 0.5 - 2.5V, with an output power @ ~-3 - 3dBm. The WCDMA VCO output frequency is controlled by an internal phase lock loop (PLL) synthesizer. The phase locked loops use a fractional loop divider to permit fast lock times and low phase noise on their output signals. The VCO output frequency is fed into a prescalar and divided down into a desired comparison frequency. The 15.36MHz reference frequency is also divided down into a comparison frequency. The two divided frequencies are then compared with a phase detector. The phase detector will then drive the charge pump. The charge pump output is processed by the external loop filter and drives the tunable resonant network, altering the VCO frequency and closing the loop.

The superfilter block is used to provide a filtered supply voltage to the WCDMA VCO.

4-26 A830: Harmony Lite (TX Section)

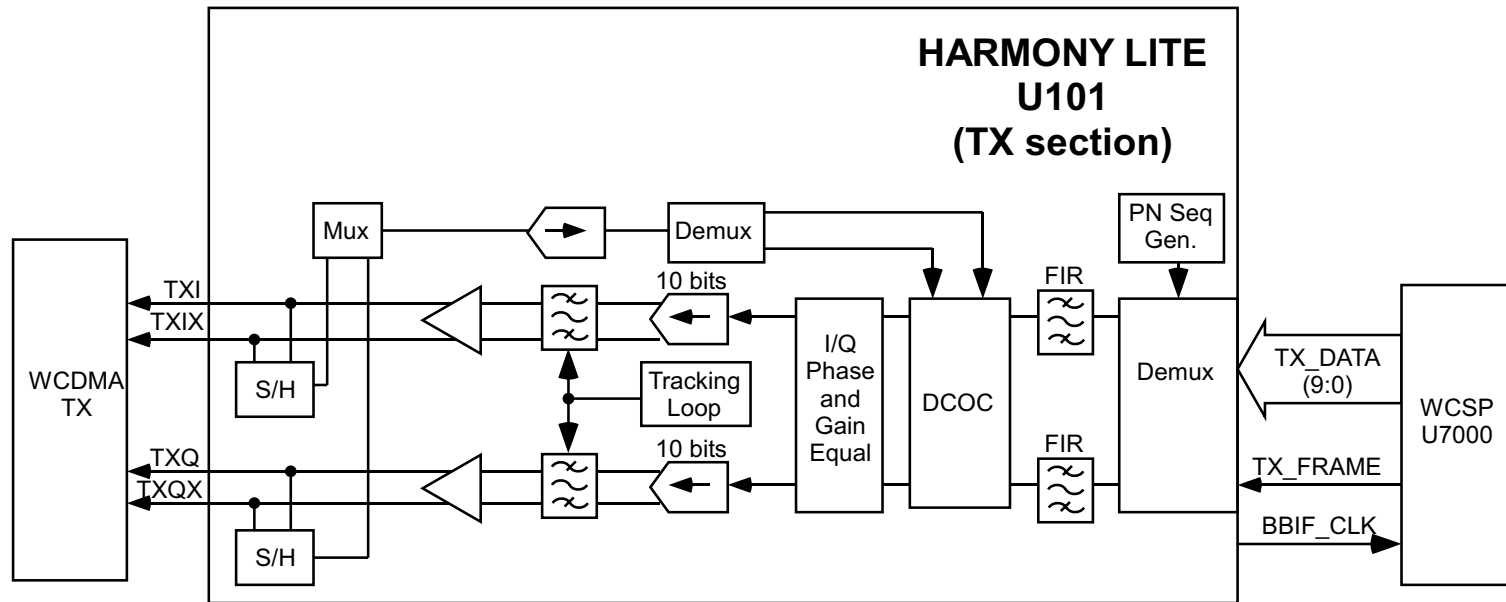

Motorola Confidential Proprietary

Description

The BBIF(TX_DATA) is the transmit data path for transferring digitally sampled I / Q data from the WCSP. The demultiplexing unit performs the I/Q deinterleaving function to supply separate I and Q channel data into the transmit FIR filters. The FIR filter design is used to meet 3GPP spec requirements of simultaneous transmission of a pilot channel and of multiple data channels each requiring a different spreading code and each requiring separate power control. The PN sequence generator provides I/Q interleaved 8-bit PN data into the demultiplexing section. The DC correction(DCOC) block is able to correct for DC offsets due to the D/A's, anti-aliasing filters, and transmit FIR filters in a feedback control loop. A mixed mode control loop located at the output of the transmit FIR filter is employed to correct DC offsets and I/Q gain imbalances, i.e. DCOC and I/Q Phase and Gain equalizer. The outputs of the I/Q gain equalization unit is fed into 10-bit I and Q DAC's. The programmable gain anti-aliasing filters, or TX smoothing filters, accepts differential I/Q signals of DC to 1.92MHz frequency components from the D/A Converters to attenuate the unwanted clock signals of 15.36MHz and to smooth the signals for the TX modulator(MAX2363). The output of the TX smoothing filters are then fed into a multiplexed 6-bit A/D with sample/hold scheme. This gives the information of the amplitude and the DC common mode voltage from the I / Q Tx filter outputs by a single Analog-to-Digital Converter (ADC) as the part of digital correction loop.

The differential TX I and TX Q signal are finally fed into the TX modulator(MAX2363).

4-28 A830: TX Modulator (MAX2363)

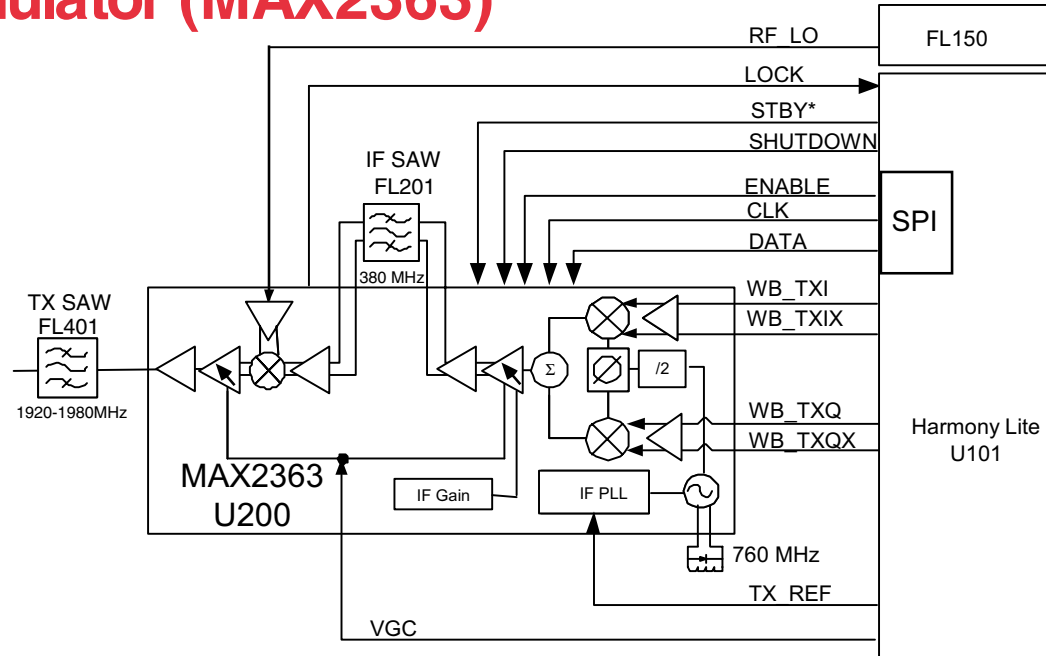

Description

The in phase (I) and quadrature phase (Q) inputs are received at pins #23 (Q+), #24(Q-), #25(I+), & #26(I-) of U200. The expected DC bias levels are 1.30V - 1.40V with a minimum 300mVpp signal upon the DC level.

The MAX2363 receives the differential I/Q BaseBand input and converts it up to the IF frequency of 380MHz through a quadrature modulator and IF variable gain amplifier (VGA). The IFIN+ (pin #10) and IFIN- (pin #11) input are connected through off-chip FL201 from IFOUT+ (pin #17) and IFOUT- (pin #16), respectively. The function of FL201 is to provide image rejection and out-of-band interferers filtering. The frequency conversion process performed by the mixer / oscillator combination sometimes will allow a frequency other than desired frequency to be fed into the IF and subsequently amplified. The SAW filter (FL201) has a nominal center frequency of 380MHz and an insertion loss of ~ 3.5dB with a total bandwidth of 5MHz.

The IF and RF VGA (VGC) are common and allow for varying the IF / RF output level. HARMONY_LITE controls the VGC signal with a range of ~1.3 - 2.6V and provides gain a control range of ~75dB.

The MAX2363 VCO output frequency is controlled by an internal phase lock loop (PLL) synthesizer. The external loop filter consists of the components connected to pins #33 and #32 (& pin #38). The VCO output frequency (TankH+ / TankH-) at pin #33 and pin #32 are divided down internally, to a desired comparison frequency. The reference signal at pin #36 (TX_REF) is also divided down to the same comparison frequency. The two divided signals are then compared with a three state digital phase detector. The internal phase detector drives the charge pump as well as the lock-detect logic (LOCK). The charge pump output (IFCP, pin # 38) is processed by the external loop filter and drives the tunable resonant network, altering the VCO frequency (760MHz) and closing the loop.

The differential IF output at pins #17 & #16 (IFOUTH+ / IFOUTH-) support high IF operation of frequency of 380MHz. The signal is routed to an off-chip IF SAW filter (FL201) and up-mixed to RF through an image reject mixer and RF VGA. The signal is further amplified with an on-chip PA driver. The RF signal is then routed to an interstage RF SAW filter (FL401).

The IF synthesizer (760 MHz VCO) and local oscillator (RF_LO) buffer are both programmable through the 3-wire bus. The sequence manager from HARMONY_LITE programs standby mode (STBY*) and shutdown mode (SHUTDOWN). This IC operates from a pair of supply voltages VCC_DIG (isolated supply for IF_CP and 760 VCO) & VCC_ANA derived from VRF_TX_2_775V.

4-30 A830: WCDMA PA

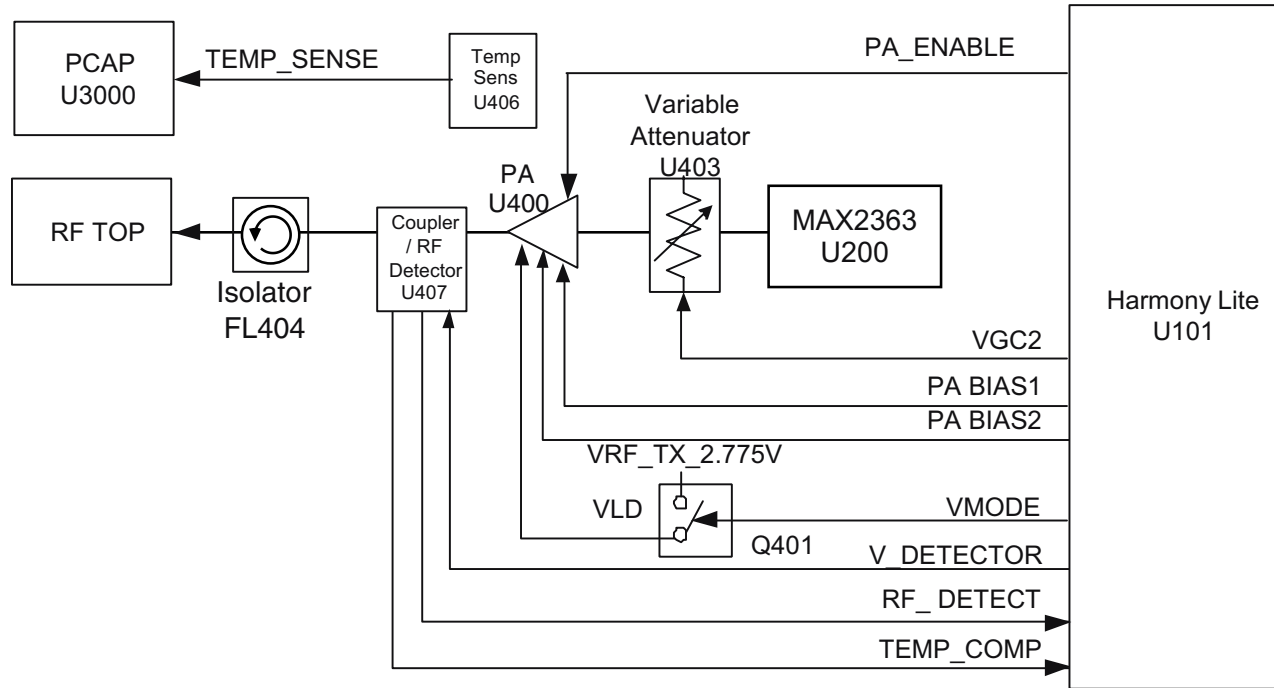

Description

The U403 provides necessary attenuation of the TX carrier before reaching the PA so that it doesn't exceed the maximum allowable input of 1dBm of the PA and to control the overall power output of the transceiver. The U403 has a 16-18 dB of attenuation depending on the control voltage VGC2 applied at HYBOUT1 and HYBOUT2, which is controlled by Harmony Lite.

U400 is a three-stage power amplifier handling the band of WCDMA Tx frequencies between 1920 - 1980MHz. The nominal expected maximum gain is ~30dB. HARMONY_LITE controls the RF biasing of the amplifier at pins #4 (PA_BIAS1) and #5 (PA_BIAS2) with a control range of 0 - 2.5v. HARMONY_LITE also controls pin #12 (VLD) for PA load switching. Although not implemented, the theory of PA load switching in WCDMA is vitally important to conserve battery life and to avoid unnecessary radio interference with base stations. When VLD is at a low state (0v), the transmitter is in high power mode, consuming higher current but with overall better PA performance. When VLD is at a high state, the transmitter is in low power mode, consuming less current with overall poor PA performance. In theory, as the Tx power level increases or decreases beyond a certain power threshold, VLD is enabled or disabled. As Tx power decreases (as requested from a base station) down to ~-14.5dBm, VLD will switch high. If Tx power is requested to increase beyond ~-19dBm, VLD is switched low.

The power detector receives the amplified WCDMA RF signal at RF_IN (pin #6) from the PA. U407 is a combination directional coupler and temperature compensated power detector with a differential output. The power detector couples the TX power input and feedbacks an output RF_DETECT to HARMONY LITE. The TEMP_COMP also obtains the coupled power but removes the RF signal content, leaving a DC level. The DC level is feedback to HARMONY LITE. Expected nominal loss is < 3dB.

The isolator provides isolation between Front-End Module (FEM) and transmitter path. Nominal insertion loss is ~ 0.55dB.

4-32 A830: Charger

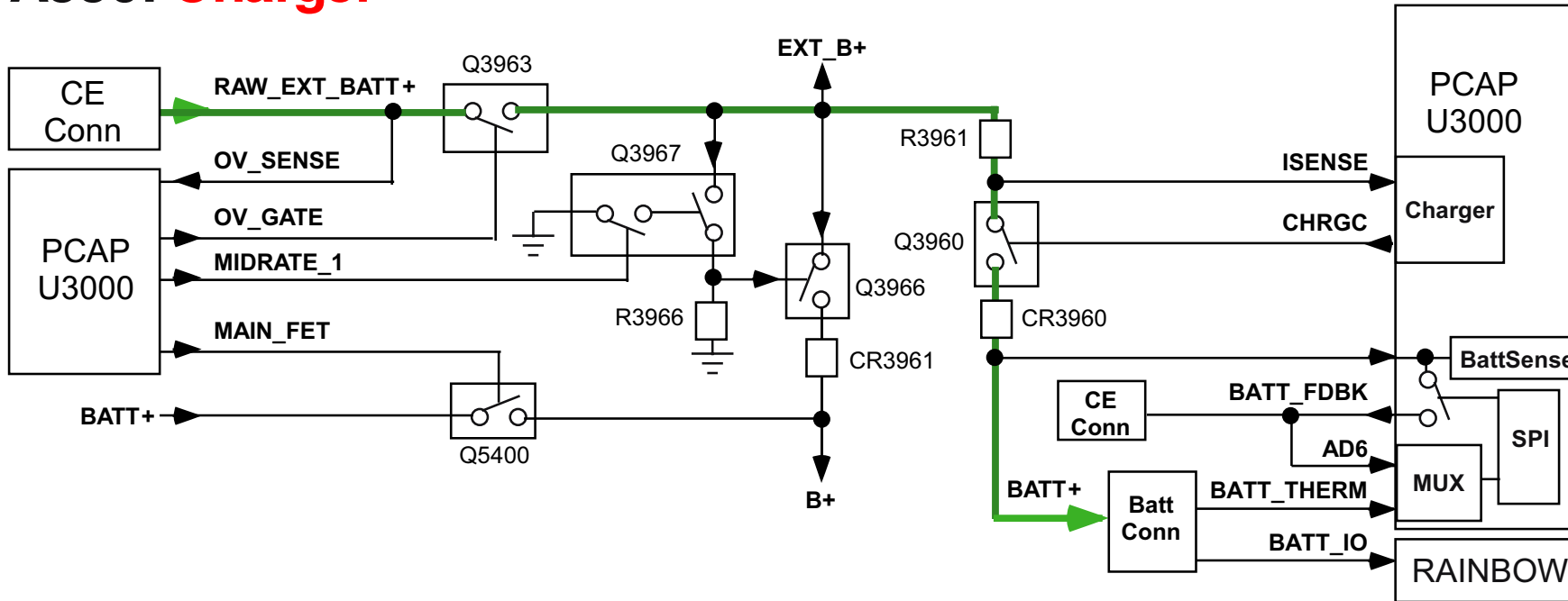

Description

The majority of the charging circuit is integrated in PCAP. This includes a digital to analog converter, analog to digital converter, battery feedback switch, thermistor switch/pullup, and current control sense. External FETs (Q3966 and Q5400) are provided to enable/disable EXT_B+ and BATTERY supply paths to radio circuitry (B+). An external sense resistor (R3961) and a charging FET (Q3960) are provided to control charging current between EXT_B+ and BATTERY.

Due to pin count constraints on the CE bus, the Charger Identification input signal and Battery Feedback output signal share the same accessory connector pin. Software will first detect the Charger ID Voltage (AD6) before enabling the Battery Feedback Voltage via the Battery Feedback Switch in PCAP. The Battery Feedback switch must not be enabled at any time for an accessory that is not a valid Fast Charger.

Battery Feedback Voltage provides a reference voltage to the external power supply during charging. The battery feedback switch is needed to remove the battery feedback voltage from the feedback loop of the AC/DC Adapter or VPA when charging is complete or after a fault has occurred. This switch will be enabled before the charger DAC is programmed when charging is to begin. Battery feedback will turn on before the charger is enabled. The charger will be turned off before battery feedback is disabled.

A thermistor in the battery package is used to determine cell temperature of the battery pack before charging begins. The battery EPROM (BATT_IO) will contain limit parameters that determine the minimum and maximum temperatures at which charging can occur.

PCAP has an integrated over-voltage detection circuit that provides protection against damage caused by external charger voltages exceeding 7.0Vdc. If an over-voltage condition occurs, the EXT_B+ FET (Q3963) will be disabled. This will prevent high voltage (>7Vdc) from being applied to radio circuitry (B+).

Mid-rate charging is supported if a valid mid-rate charger and valid battery are detected. A mid-rate charger will source up to 400mA of current to the radio circuitry and charging circuitry during idle mode. The mid-rate charger will supply 5.9Vdc (up to 400mA) to the phone, regardless of the BATT_FDBK voltage. If the phone is in transmit mode, mid-rate current will be supplied to the battery and radio circuitry via the charging path only (EXT_B+ FET (Q3966) will be disabled via the MIDRATE_1 line). Dead battery TX operation or 'No Battery' operation is not supported with a mid-rate charger.

4-34 A830: Voltage Regulators

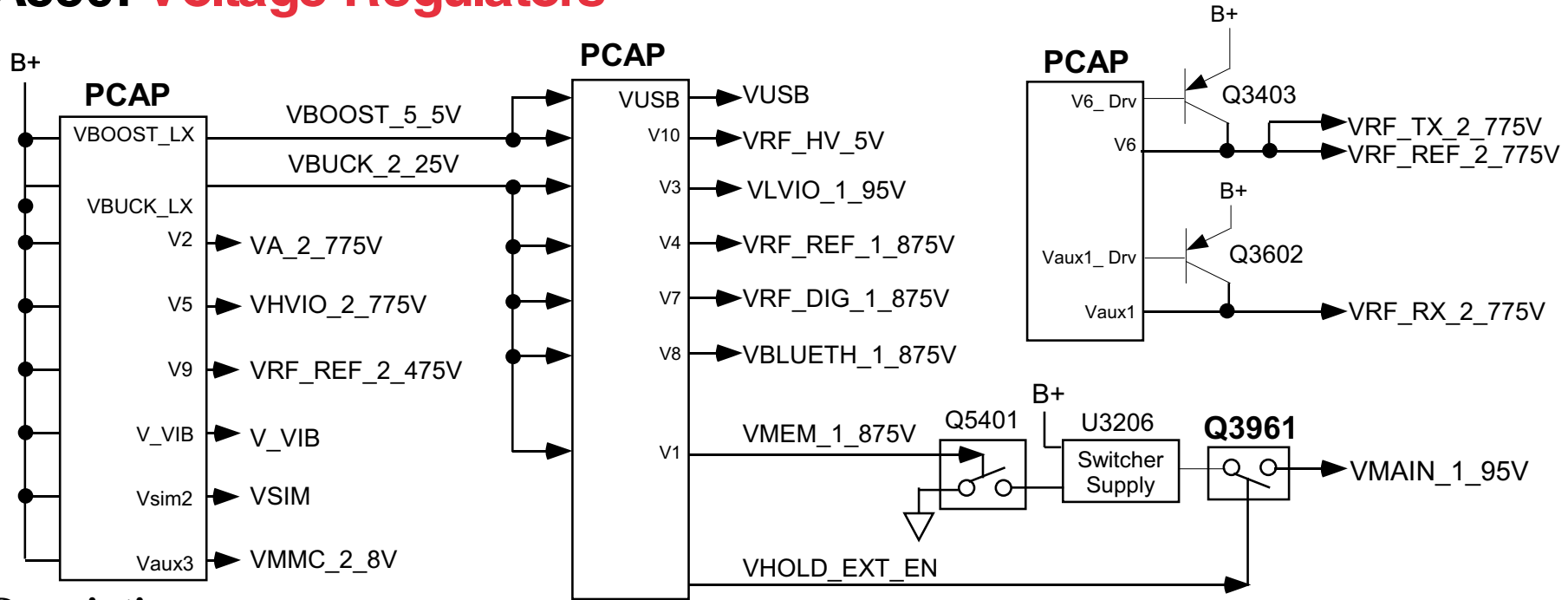

Description

Voltage regulation is provided by the GCAP IC (U1100). Multiple regulators are used to provide better isolation between sensitive load circuitry and noisy circuitry.

The regulators and their load circuitry are described below:

- VBOOST_LX(VBOOST_5_5V) - VUSB and V10 input voltage regulator
- VBUCK_LX(VBUCK_2_25V) - V1, V3, V4, V7, and V8 input voltage regulator
- V_VIB - Vibrator
- Vsim2(VSIM) - SIM card interface
- Vaux1(VRF_RX_2_775V) - RF RX circuits
- Vaux3(VMMC_2_8V) - SD/MMC interface
- VUSB - USB interface
- V1(VMEM_1_875V) - Flash Core
- V2(VA_2_775V) - Audio, ADC/DACs, Baseband Processor Peripherals, LCD and EL back-lighting
- V3(VLVIO_1_95V) - Rainbow I/O, and Flash I/O
- V4(VRF_REF_1_875V) - Magic LV reference
- V5(VHVIO_2_775V) - Rainbow I/O, and Bluetooth I/O
- V6(VRF_TX_2_775V) - RF TX circuits
- V7(VRF_DIG_1_875V) - Magic LV, and Harmony Lite
- V8(VBLUETH_1_875V) - Bluetooth
- V9(VRF_REF_2_475V) - WCDMA PA Reference
- V10(VRF_HV_5V) - Magic LV and FEM

A830: RX Audio

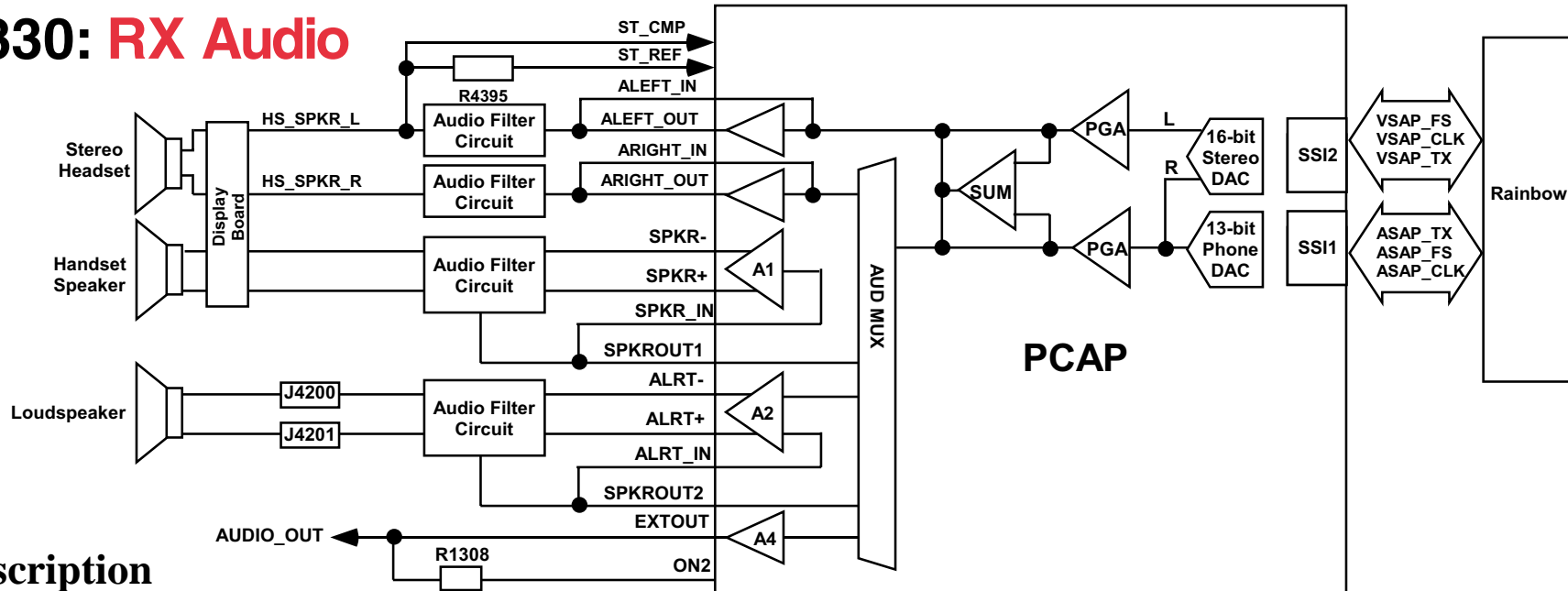

Description

Receive audio data is transferred from the Rainbow to the PCAP through the ASAP interface for mono audio and the VSAP interface for stereo audio data. The data is then converted into an analog form through a 16-bit Stereo DAC or 13-bit phone DAC. The output of PCAP's internal DAC drives the internal PGA. The output of the PGA can be routed to one of the four supported outputs via the internal multiplexer. All outputs use the same D/A converter so only one output can be active at one time. The user can adjust the gain of the audio outputs with the volume control buttons.

The Handset Speaker is driven by PCAP's internal SPKR differential amplifier. Following the speaker path from the PCAP pins SPKR- and SPKR+, they are routed through R4004 and R4005 respectively, and then connected to the transducer. Off the SPKR- path, SPKR_IN is routed through C4002 for the inverting input of the speaker amp A1. SPKR_OUT1 from PCAP is routed through C4000 and C4002 to SPKR- which is the DAC output of the CODEC. SPKR_IN and SPKR_OUT1 will output their respective bias voltages on these pins during standby times. This is to maintain the voltage across an external coupling capacitor to avoid audio "pops" when the amplifier is enabled.

The headset uses a standard 2.5mm stereo phone jack. The phone will detect the presence of a stereo headset using HS_SPKR_L of the headset jack, which is pulled high by R4395 and connected to the ST_COMP of PCAP (this is an interrupt of PCAP which gets sent to MCU over the SPI bus). This pin will be pulled to a logic low whenever the stereo headset plug is inserted into the jack. The headset may contain a momentary switch, which is normally closed and is in series with the microphone cartridge. When the momentary switch is pressed, the bias current being supplied to the microphone will be interrupted. The phone will detect this action and make an appropriate response to this action, which could be to answer a call, end a call, or dial the last number from scratchpad.

The Headset Speaker is driven by PCAP's internal Left and Right amplifier. Following the speaker path from the PCAP pins ARight_Out and ALeft_Out, they are routed through C4356, R4352 and C4306, R4302 respectively, and then connected to the headset jack. Off the ARight_Out path, AR_IN is tapped off through C4354 for the inverting input of the audio amp ARIGHT. Off the ALeft_Out path, AL_IN is tapped off through C4304 for the inverting input of the audio amp ALEFT.

The External Speaker is connected to pin 15 of J5000 (AUDIO_OUT), the accessory connector for the mobile phone. The audio path is routed through R4400 and C4400 and connected to EXTOUT of PCAP. The DC level of this Audio_Out signal is also used to externally command the phone to toggle it's ON/OFF state. The Audio_Out signal connects to PCAP's ON2 pin via R5053 to provide this capability. When a DC level of <0.4V is applied by an accessory for a minimum of 700 milliseconds on the Audio_Out line, the phone will toggle it's ON/ OFF state.

The Loudspeaker is driven by PCAP's ALRT amplifier (A2). The alert path from the PCAP pins ALRT- and ALRT+ are routed directly to the alert transducer. Off the ALRT- path, ALRT_IN is routed through R4201 for the inverting input of the alert amp A2. SPKROUT2 from PCAP is routed through C4200 and R4200 to ALRT- which is the DAC output of the CODEC.

4-38 A830: TX Audio

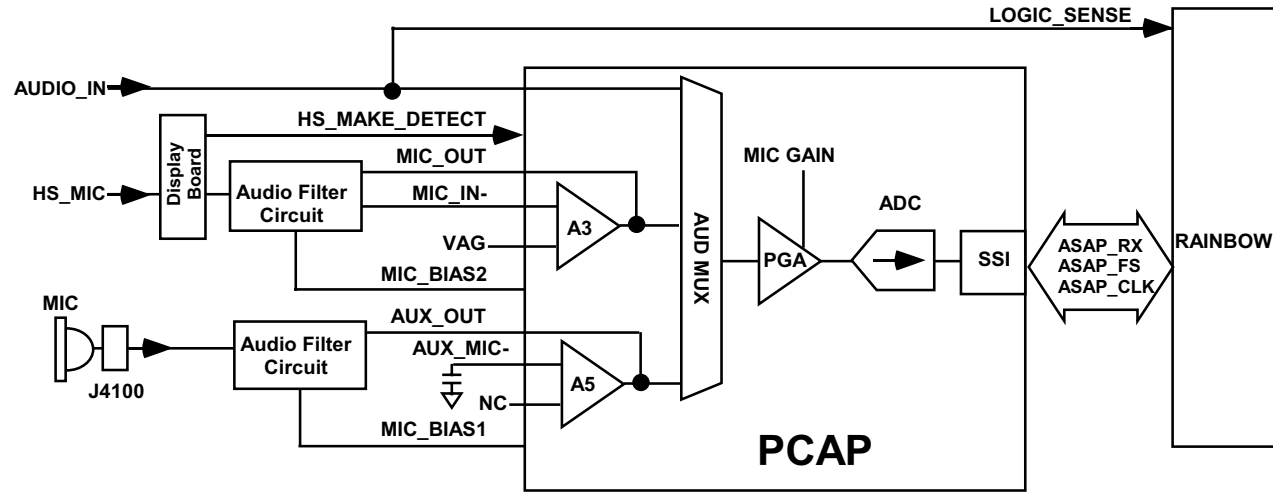

Description

The Internal Microphone is a single ended part. Following the Internal microphone path, the microphone is biased by R4103 to provide a MIC_BIAS of 2.0V from pin MIC_BIAS1 of PCAP. C4198 is connected to MIC_BIAS1 and MB_CAP1 pin on PCAP to bypass the gain from the VAG to MIC_BIAS1 which keeps the noise balanced. From there, the signal is routed through C4100 to AUX_OUT pin on PCAP, bypassing the input to the A5 amplifier.

The headset microphone path (HS_MIC) is biased through R4396 and R4392, which is connected to pin MIC_BIAS2 on PCAP and bypassed with C4199 connected to pin MB_CAP2. From here the signal is routed through C4395 and R4388 to MIC_IN- pin on PCAP, which is the input to the A3 Amplifier. The Microphone path is tapped off after R4388 before the MIC_IN- input to R4389 connected to the MIC_OUT pin on PCAP, which is the output of the A3 Amplifier. The HS_MAKE_DET line monitors the presence of a headset by detecting the voltage at A1_INT of PCAP, which passes through R4398. A switching mechanism integrated in the headset jack will open or close the HS_MAKE_DET path to ground, depending on whether the headset is attached or not.

The External Microphone input (AUDIO_IN) is connected to the accessory connector for the mobile phone. The path is routed through L4400, C4401 and R4401 to the EXT_MIC pin on PCAP. This signal feeds directly to the input multiplexer without an intervening gain stage. In addition to audio signals, AUDIO_IN supports detection of accessory devices. The accessory attached to the CE bus shall have an output impedance that will load LOGIC_SENSE to a predetermined level. The RAINBOW will read the input level of LOGIC_SENSE and configure the audio accordingly.

The proper Microphone path is selected by the AUD MUX controller and path gain is programmable at the PGA. The A/D converter will convert incoming analog signals into 13-bit, 2's complement, linear PCM words. The digital audio signals are then transferred to the Rainbow DSP through a four wire serial interface (ASAP).

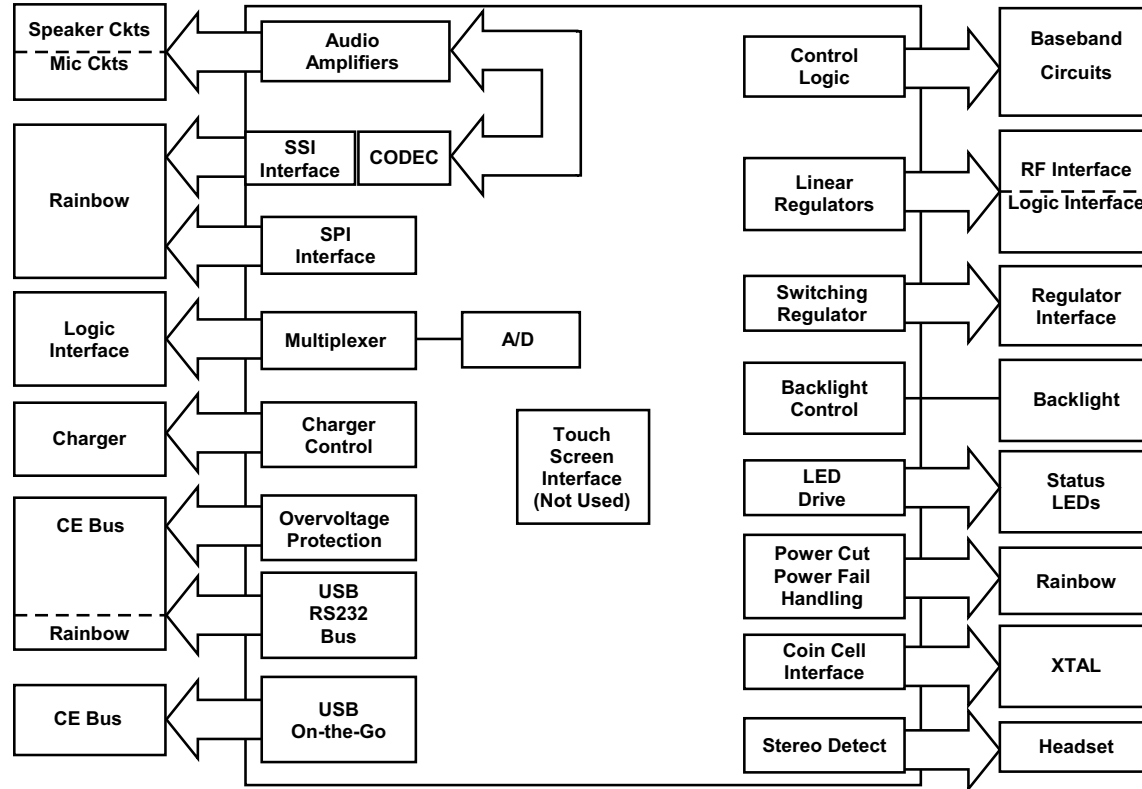

Description

The Platform Control Audio Power IC (PCAP), U3000, is a mixed signal IC that contains the following features:

- Audio input/output amplification and filtering
- Audio path selection
- Voltage regulation
- Battery charging control
- Real time clock
- Ringer/vibrator control
- RS-232/USB drivers
- Back-light control
- Status LED control
- Multiplexed DAC inputs for temperature and voltage monitoring
- Dual SPI control interface to allow access from two independent baseband processors
- Stereo DAC
- Overvoltage protection

The PCAP IC is controlled and configured by the Baseband Processor IC through a four-wire SPI interface. The Baseband Processor has read/write access to the PCAP IC. Audio data is transmitted/received via the Baseband Processor through a four-wire SSI interface.

4-42 A830: RAINBOW

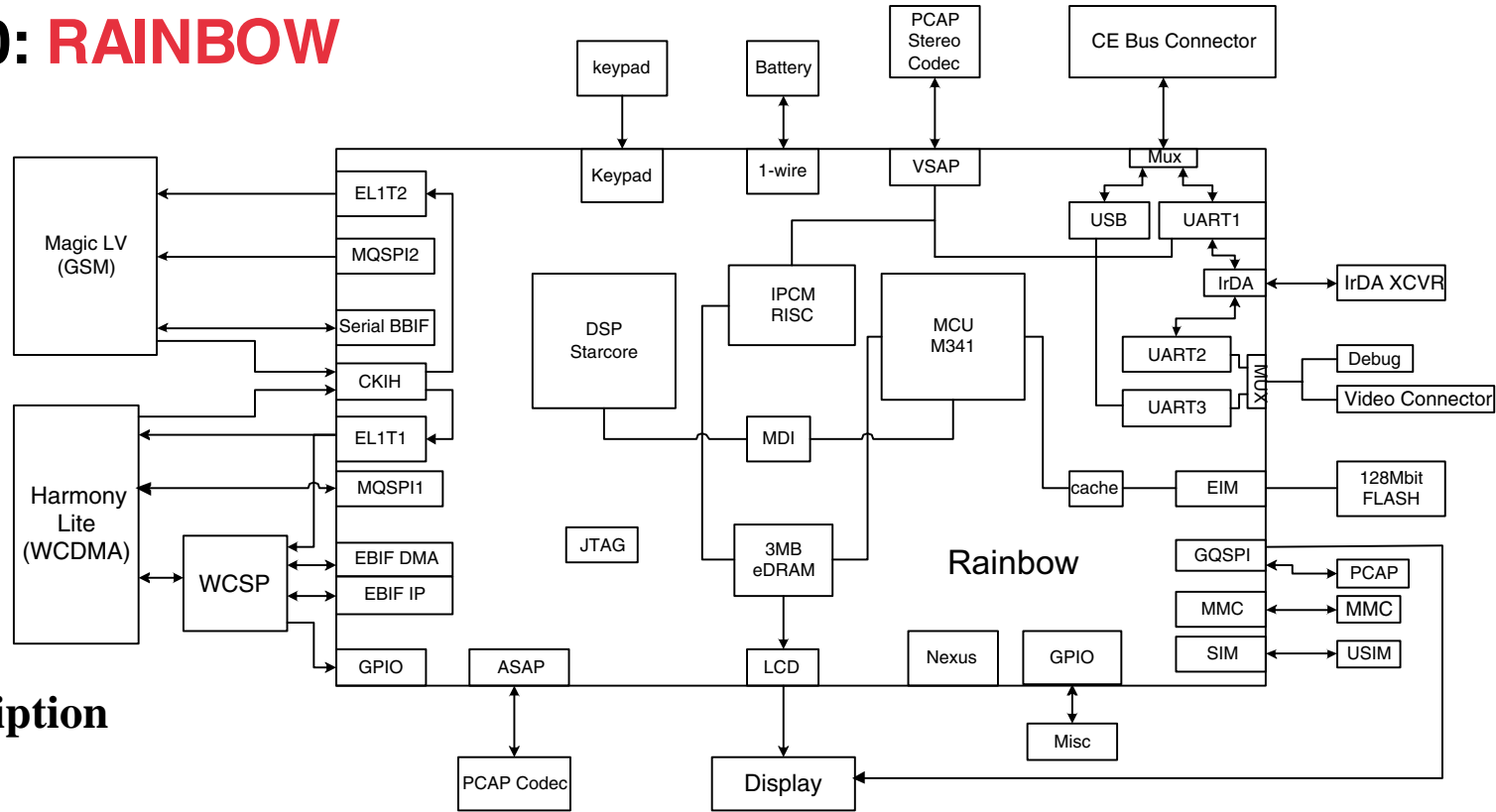

Description

The logic architecture is built around the Rainbow multi-core processor and the PCAP power management IC. The PCAP integrates several linear and switching voltage regulators, audio codecs and amplifiers, serial and USB transceivers, backlight and service-light LED controllers and digital interfaces to the Rainbow cores.

The Rainbow integrates a 32-bit RISC Communications Engine (MCU), a 32-bit DSP Core and an Interprocessor Communications Module (IPCM) along with associated peripherals and co-processors. The following provides a brief description of the cores and associated peripherals.

- MCU – Micro Controller
- DSP for GSM Signal processing
- EIM(external interface module) interfaces to FLASH and DRAM
- USB/Serial Communications
- GPIO - For A/Ds, LED, backlight, and vibrator control
- IPCM which provides a multichannel DMA between the Mcore, DSP and peripherals.
- WCSP Interface
- GQSPI - PCAP Interface
- EBIF(External Bus Interface) DMA – WCDMA Data Transportation
- MQSPI1(Qued Serial Peripheral Interface) – WCDMA Control Signals
- EL1T1(Enhance Layer Timer) – WCDMA Event timer
- CLIH - WCDMA 15.36MHz clock

- 1 wire Communication for Battery EPROM
- Keypad Interface
- Display Interface
- USIM interface
- IrDA interface
- MMC interface
- ASAP interface for PCAP and Bluetooth audio interface
- VSA interface for PCAP stereo Codec
- Serial BBIF(Baseband Interface) – GSM Data Transportation
- MQSPI2(Qued Serial Peripheral Interface) – GSM Control Signals
- EL1T2(Enhance Layer Timer) – GSM Event timer
- CLIH - GSM 13MHz clock

In addition to Rainbow's internal memory system, the architecture provides 128Mbits (16M byte) of external flash memory via two Intel Whytecliffe 64M bit parts. The memory bus is 23 address bits and 32 data bits. The flash memory runs at 50MHz.

4-44 A830: WCSP

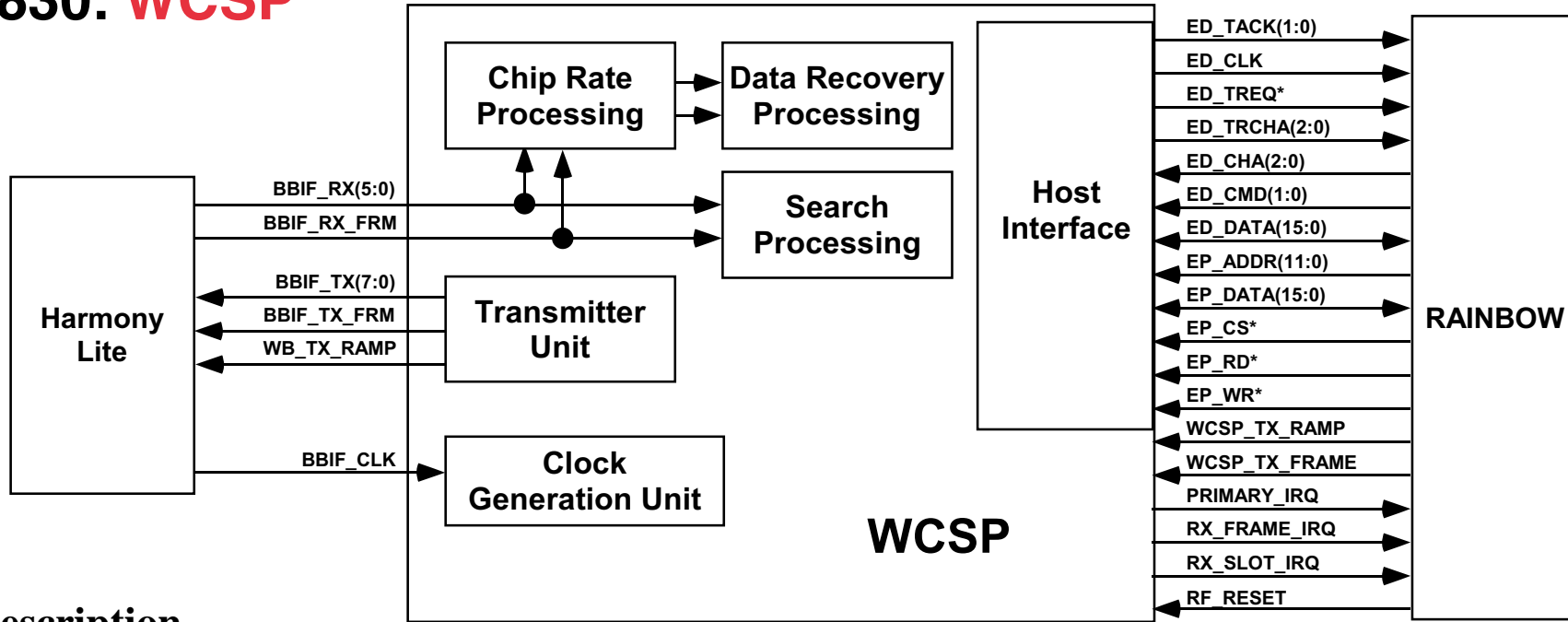

Description

The WCSP consists of five distinct functional units: the Transmitter Processing Unit, the Chip Rate Processing Unit, the Data Recovery Processing Unit, the Search Processing Unit, and the Host Interface Unit. Within Rainbow, the WCSP will interface to the DSP Peripheral and DMA buses using the existing EBIF interface. A Turbo Decoder Unit has also been developed for an FPGA implementation. When integrated within Rainbow, the Turbo Decoder engine will be implemented as a peripheral on the DSP Peripheral Bus. The Turbo memory, however, will be integrated within the DSP SRAM.

The Transmitter Unit implements the chip-rate processing functions of the reverse link defined in the 3GPP specifications. The framed data, which has been assembled within the DSP, is stored within an input buffer, spread by an OVSF channelization sequence, and spread in quadrature by the I and Q scrambling code PN sequences. The gating of the transmit power amplifier is controlled via the output pin PA_ENABLE.

The Chip Rate Processing Unit is responsible for the front-end reception of the forward link waveform defined in 3GPP specifications. The unit accepts 6-bit I and Q samples (RXI and RXQ) from the baseband interface at a rate of four times the chip rate of 3.84 MHz. The Chip Rate Processor then despreads and correlates the received signal (i.e., removes the scrambling and channelization PN codes) using eight independent rake branches.

The Data Recovery Processing Unit performs coherent demodulation of the forward link signal. Within the unit, a channel estimate is generated for each rake receiver branch using FIR filtering methods. By multiplying this internally generated estimate by the correlated data, which is produced by the Chip Rate Processing Unit, coherently demodulated data can be generated. From the eight branches, the data streams are then deskewed, combined, stored in an output buffer. The combined data symbols may be accessed by the DSP through one of the EBIF DMA channels.

The Search Processor Unit attempts to locate received signal paths having sufficient energy for demodulation. These high energy paths are detected when the receiver PN code sequences are time-aligned with the sequences applied at the base transmitter.

The Host Interface Unit provides the WCSP's interface to the EBIF peripheral and DMA buses. On the peripheral interface, this block converts the data, address, and control signals into the format required by the WCSP's internal registers.

4-46 A830: Bluetooth IC

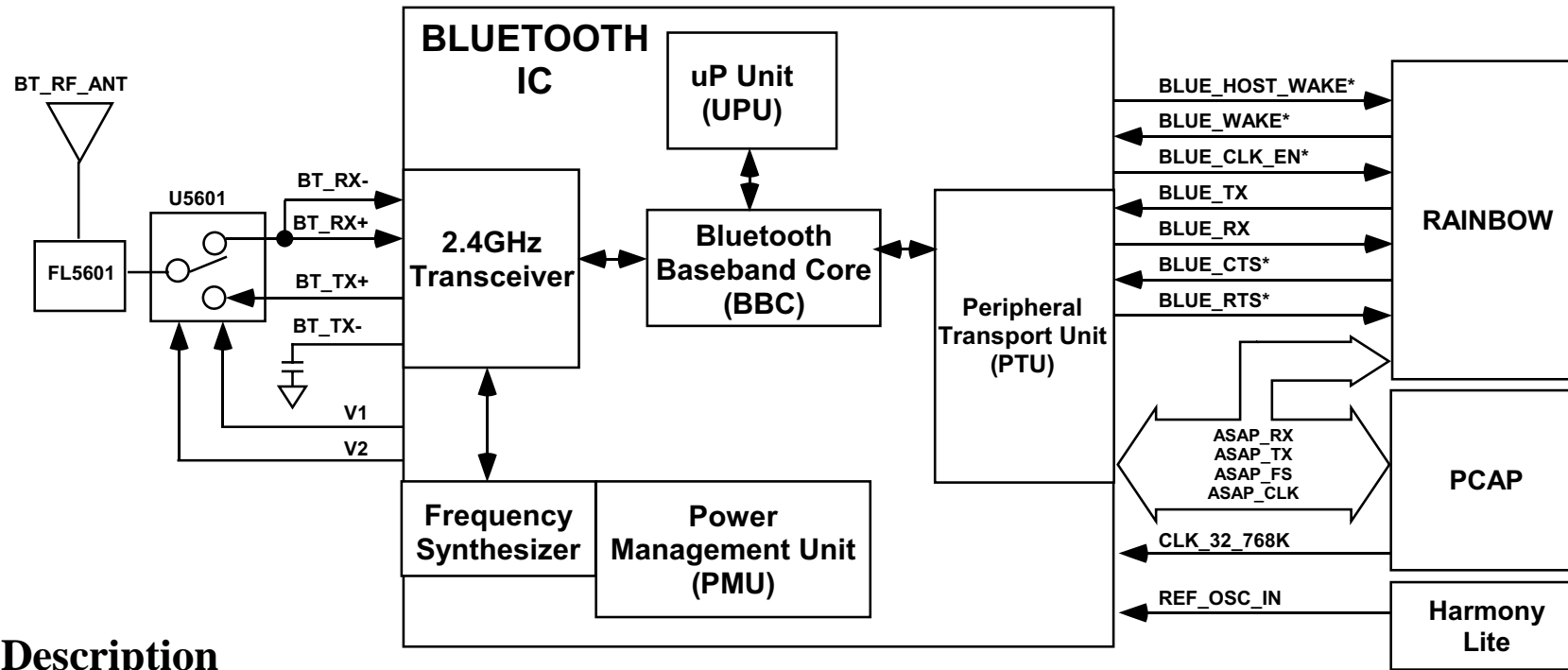

Description

The BCM2033 has an integrated radio transceiver that has been optimized for use in 2.4 GHz Bluetooth wireless systems. It has been designed to provide low-power, low-cost, robust communications for applications operating in the globally available 2.4 GHz unlicensed ISM band. It is fully compliant with the Bluetooth RF Specification v1.1 and meets or exceeds the requirements to provide the highest communication link quality of service.

The receiver has a high degree of linearity, an extended dynamic range, and high order on-chip channel filtering to ensure reliable operation in the noisy 2.4 GHz ISM band. The BCM2033 also features a fully integrated transmitter. Baseband data is GFSK modulated and upconverted to the 2.4 GHz ISM band via an internal mixer. The output Power Amplifier (PA) provides a nominal power output of 0 dBm and has a power control to provide 24 dB of gain control in 8 dB step sizes. Local Oscillator (LO) generation provides fast frequency hopping (1600 hops/second) across the 79 maximum available channels.

The uPU runs software from the Link Control (LC) layer, up to the Host Controller Interface (HCI). The microprocessor is an enhanced performance 8051 micro-controller.

The BBC manages the buffering, segmentation, and routing of data for all connections. It also buffers data that passes through it, handles data flow control, schedules SCO/ACL TX/RX transactions, monitors Bluetooth slot usage, optimally segments and packages data into baseband packets, manages connection status indicators, and composes and decodes HCI packets.

The Peripheral Transport Unit (PTU) handles the Device Interface. The PTU supports three types of devices: USB, UART, and PCM.

The PMU provides power management features that can be invoked by either software through power management registers, or “packet handling” in the baseband core.