

Revision Overview
Rev. 1.0: Initial Block Diagram

A1600

GSM SERVICE SUPPORT GROUP	2008.05.13
LEVEL 3 AL Block Diagram	Rev. 1.0
A1600	
	Page 1 of 3

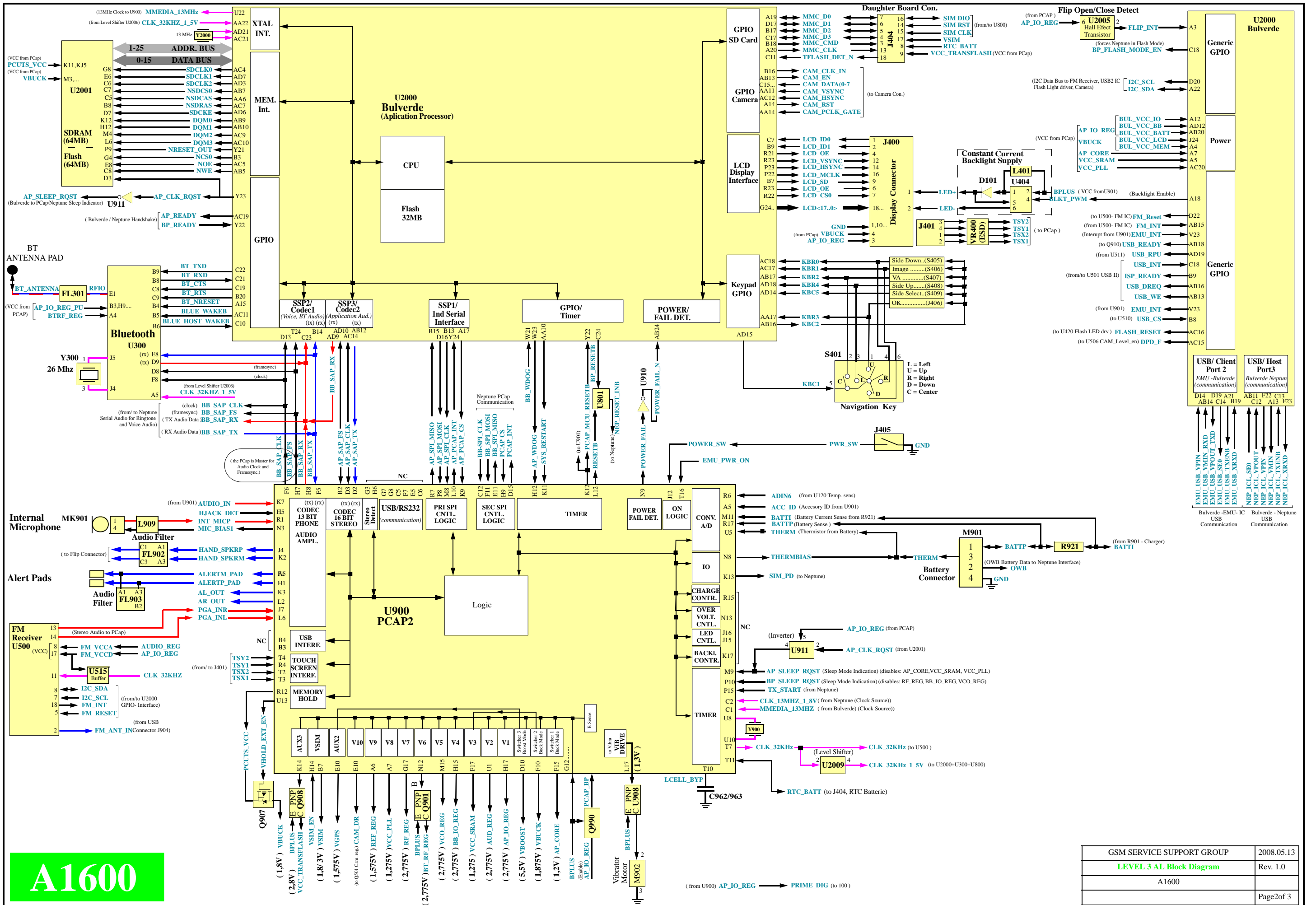

A1600

GSM SERVICE SUPPORT GROUP	2008.05.13
LEVEL 3 AL Block Diagram	Rev. 1.0
A1600	
	Page2of 3

A1600

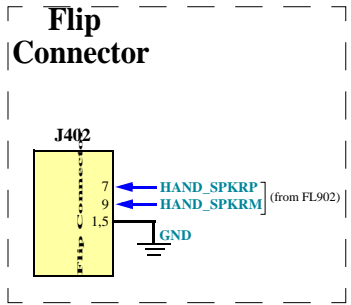

USB - Fast and High Speed Interface (1.1 and 2.0)

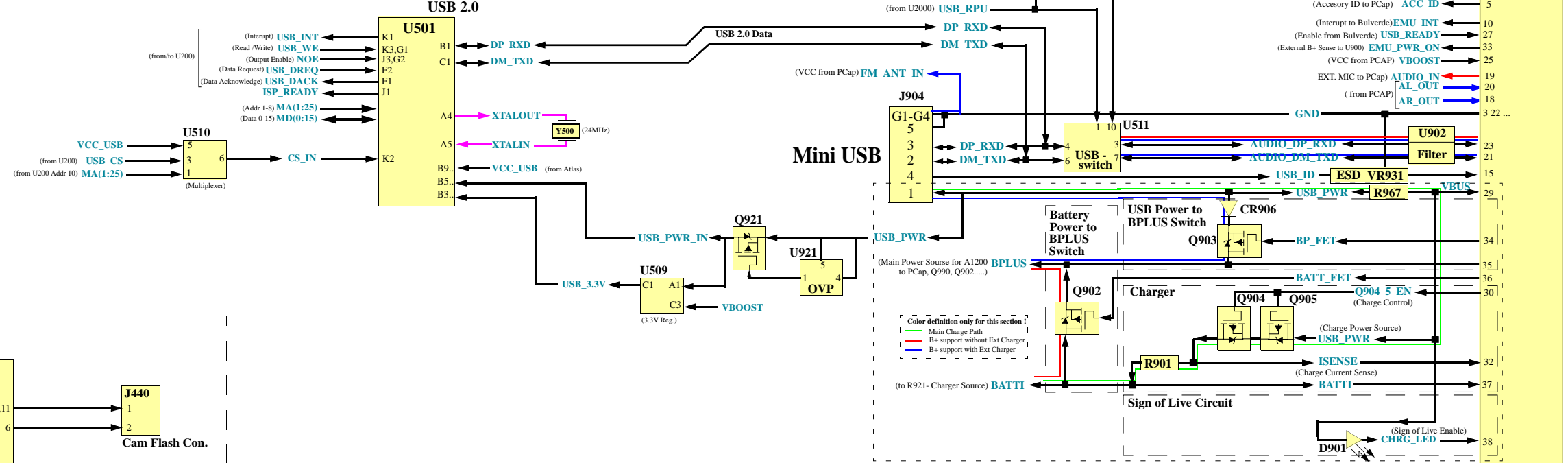

Cam Flash Circuit

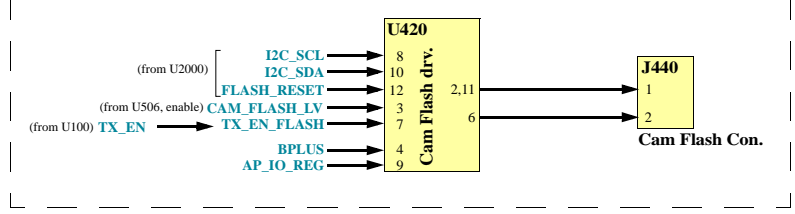

CAM Conector

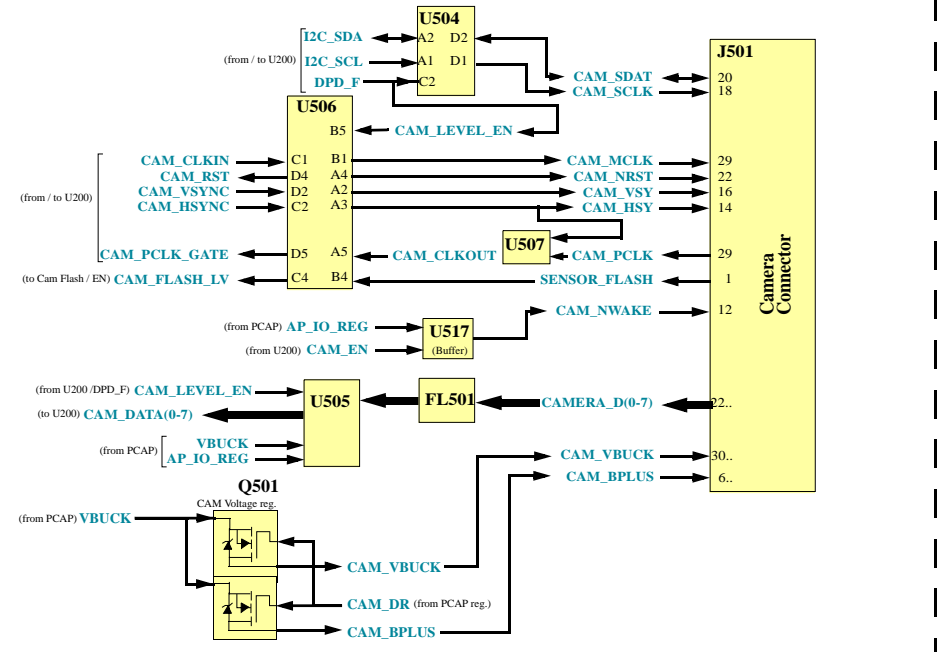

AGPS Receiver

